

# RULES ON MATERIALS AND WELDING FOR THE CLASSIFICATION OF MARINE UNITS

NR216 - JANUARY 2024



MATERIALS & WELDING



BUREAU  
VERITAS

# RULES ON MATERIALS AND WELDING FOR THE CLASSIFICATION OF MARINE UNITS

**NR216 DT R15 JANUARY 2024**

---

This version of the document takes precedence over previous revision. Unless otherwise specified, these rules apply to ships for which contracts are signed on or after January 1st, 2024. The Society may refer to the contents hereof before January 1st, 2024, as and when deemed necessary or appropriate.

The PDF electronic version of this document available on the Bureau Veritas Marine & Offshore website <https://marine-offshore.bureauveritas.com/> is the official version and shall prevail if there are any inconsistencies between the PDF version and any other available version.

These rules are provided within the scope of the Bureau Veritas Marine & Offshore General Conditions, enclosed at the end of Part A of NR467, Rules for the Classification of Steel Ships. The latest version of these General Conditions is available on the Bureau Veritas Marine & Offshore website.

**BUREAU VERITAS MARINE & OFFSHORE**

Tour Alto  
4 place des Saisons  
92400 Courbevoie - France  
+33 (0)1 55 24 70 00

[marine-offshore.bureauveritas.com/rules-guidelines](https://marine-offshore.bureauveritas.com/rules-guidelines)

© 2024 BUREAU VERITAS - All rights reserved





NR216

# RULE ON MATERIALS & WELDING FOR THE CLASSIFICATION OF MARINE UNITS

---

Chapter 1	General Requirements
Chapter 2	Testing Procedures for Materials
Chapter 3	Rolled Steel Plates, Sections and Bars
Chapter 4	Steel Pipes, Tubes and Fittings
Chapter 5	Steel Forgings
Chapter 6	Steel Castings
Chapter 7	Iron Castings
Chapter 8	Copper and Copper Alloys
Chapter 9	Aluminium Alloys
Chapter 10	Equipment for Mooring and Anchoring
Chapter 11	Type Approval of Welding Consumables
Chapter 12	Welding
Chapter 13	Other Products
Chapter 14	Advanced Non-Destructive Techniques

# Table of Content

---

## Chapter 1 General Requirements

<b>Section 1</b>	<b>Manufacture, Testing, Certification</b>	
1	<b>General</b>	<b>26</b>
	1.1 Scope	
	1.2 Other specifications	
	1.3 Information to be supplied by the purchaser	
2	<b>Manufacture and quality</b>	<b>26</b>
	2.1 General	
	2.2 Chemical composition	
	2.3 Condition of supply	
	2.4 Identification of products	
3	<b>Survey and testing</b>	<b>27</b>
	3.1 General conditions	
	3.2 Alternative survey scheme (known as BV Mode I)	
	3.3 Sampling for mechanical tests	
	3.4 Mechanical tests	
	3.5 Re-test procedures	
	3.6 Visual, dimensional and non-destructive examinations	
	3.7 Repairs of defects	
4	<b>Identification and certification</b>	<b>30</b>
	4.1 Identification and marking	
	4.2 Documentation and certification	
<b>Section 2</b>	<b>Correspondence with Former Edition of the Rules</b>	
1	<b>Table of correspondence</b>	<b>32</b>
	1.1 Table	

---

## Chapter 2 Testing Procedures for Materials

<b>Section 1</b>	<b>General</b>	
1	<b>Testing</b>	<b>35</b>
	1.1 Scope	
2	<b>Testing machines</b>	<b>35</b>
	2.1 General requirements	
3	<b>Preparation of test specimens</b>	<b>35</b>
	3.1 General requirements	
<b>Section 2</b>	<b>Tensile Test</b>	
1	<b>Test specimens and testing procedure</b>	<b>36</b>
	1.1 Tensile test specimens	
	1.2 Tensile test procedure	
	1.3 Tensile re-test procedure	
<b>Section 3</b>	<b>Bend Test</b>	
1	<b>Test specimens and testing procedure</b>	<b>41</b>
	1.1 Flat bend test specimen	
	1.2 Bend test procedure	

# Table of Content

<b>Section 4</b>	<b>Charpy V-Notch Impact Test</b>	
1	Test specimens and testing procedure	42
1.1	Sampling	
1.2	Charpy V-notch test specimens	
1.3	Charpy V-notch test procedure	
1.4	Charpy V-notch re-test procedure	
<b>Section 5</b>	<b>Drop Weight Test</b>	
1	General requirements	44
1.1	Test procedure and test specimens	
<b>Section 6</b>	<b>Ductility Tests for Pipes and Tubes</b>	
1	Flattening test	45
1.1	Test specimens and testing procedure	
2	Drift expanding test	45
2.1	Test specimens and testing procedure	
3	Flanging test	45
3.1	Test specimens and testing procedure	
4	Ring expanding test	46
4.1	Test specimens and testing procedure	
5	Ring tensile test	46
5.1	Test specimens and testing procedure	
6	Bend test on pipes and tubes	47
6.1	Test specimens and testing procedure	
<b>Section 7</b>	<b>Other Tests</b>	
1	Strain age embrittlement test	48
1.1	Test specimens and testing procedure	
2	Macrographic and micrographic examinations	48
2.1	Test specimens and testing procedure	
3	Crack Tip Opening Displacement (CTOD) test	48
3.1	Test specimens and testing procedure	

---

## Chapter 3 Rolled Steel Plates, Sections and Bars

<b>Section 1</b>	<b>General Requirements</b>	
1	Scope	50
1.1	General	
2	Manufacturing process	50
2.1	Steel elaboration and casting	
3	Approval	50
3.1	Steelmaking and rolling process	
4	Quality of materials	50
4.1	General requirements	
5	Visual, dimensional and non-destructive examinations	50
5.1	General requirements	

# Table of Content

6	Surface quality	51
	6.1 General requirements	
7	Condition of supply	52
	7.1 General requirements	
8	Sampling and testing	52
	8.1 General requirements	
9	Identification and marking	54
	9.1 General requirements	
10	Documentation and certification	54
	10.1 General requirements	
<b>Section 2</b>	<b>Normal and Higher Strength Steels for Hull and other Structural Applications</b>	
1	Requirements	56
	1.1 Scope	
	1.2 Steel grades	
	1.3 Manufacture	
	1.4 Surface quality	
	1.5 Internal soundness	
	1.6 Condition of supply	
	1.7 Chemical composition	
	1.8 Mechanical properties	
	1.9 Mechanical tests	
<b>Section 3</b>	<b>Normal and Higher Strength Corrosion Resistant Steels for Cargo Oil Tanks</b>	
1	Requirements	64
	1.1 Scope	
	1.2 Steel grades	
	1.3 Manufacture	
	1.4 Chemical composition	
	1.5 Marking	
<b>Section 4</b>	<b>EH47 and Crack Arrest Steel Plates for Container Carriers</b>	
1	Requirements	65
	1.1 Scope	
	1.2 Steel grades	
	1.3 Manufacture	
	1.4 Condition of supply	
	1.5 Chemical composition	
	1.6 Mechanical properties	
	1.7 Crack arrest properties	
	1.8 Mechanical tests	
<b>Section 5</b>	<b>Extra High Strength Steels for Welded Structures</b>	
1	Requirements	68
	1.1 Scope	
	1.2 Steel grades	
	1.3 Manufacture	
	1.4 Condition of supply	
	1.5 Chemical Composition	
	1.6 Mechanical properties	
	1.7 Mechanical tests	
	1.8 Marking	

# Table of Content

<b>Section 6</b>	<b>Steels for Boilers and Pressure Vessels</b>	<b>74</b>
1	Requirements	
1.1	Scope	
1.2	Steel grades	
1.3	Manufacture	
1.4	Condition of supply	
1.5	Chemical composition	
1.6	Mechanical properties	
1.7	Mechanical properties at elevated temperatures	
1.8	Mechanical tests	
<b>Section 7</b>	<b>Ferritic Steels for Low Temperature Service</b>	<b>79</b>
1	Requirements	
1.1	Scope	
1.2	Steel grades	
1.3	Manufacture	
1.4	Condition of supply	
1.5	Chemical composition	
1.6	Mechanical properties	
1.7	Mechanical tests	
<b>Section 8</b>	<b>Steels for Machinery</b>	<b>83</b>
1	Requirements	
1.1	Scope	
1.2	Steel grades and relevant properties	
1.3	Manufacture and condition of supply	
1.4	Mechanical tests	
<b>Section 9</b>	<b>Stainless Steel Products</b>	<b>85</b>
1	Requirements	
1.1	Scope	
1.2	Steel grades	
1.3	Manufacture	
1.4	Condition of supply	
1.5	Chemical composition	
1.6	Mechanical properties	
1.7	Mechanical tests	
1.8	Metallographic structure	
1.9	Intergranular corrosion test	
1.10	Through thickness tests	
<b>Section 10</b>	<b>High Manganese Austenitic Steel</b>	<b>88</b>
1	Requirements	
1.1	Scope	
1.2	Steel grades	
1.3	Manufacture	
1.4	Condition of supply	
1.5	Chemical composition	
1.6	Mechanical properties	
1.7	Mechanical tests	



# Table of Content

<b>Section 11</b>	<b>Clad Steel Plates</b>	
1	<b>Requirements</b>	90
1.1	Scope	
1.2	Steel grades	
1.3	Manufacture	
1.4	Condition of supply	
1.5	Chemical composition	
1.6	Mechanical properties	
1.7	Mechanical tests	
1.8	Corrosion testing	
1.9	Ultrasonic testing	
1.10	Surface defects and repairs	
1.11	Adhesion defects in the cladding and repairs	

<b>Section 12</b>	<b>Steels with Specified Through Thickness Properties</b>	
1	<b>Requirements</b>	92
1.1	Scope	
1.2	Steel grades	
1.3	Manufacture	
1.4	Chemical composition	
1.5	Mechanical properties	
1.6	Mechanical tests	
1.7	Test preparation	
1.8	Test results	
1.9	Re-test	
1.10	Ultrasonic testing	
1.11	Marking	

---

## Chapter 4 Steel Pipes, Tubes and Fittings

<b>Section 1</b>	<b>General Requirements</b>	
1	<b>Scope</b>	96
1.1	General	
1.2	Other specifications	
1.3	Special requirements	
2	<b>Manufacturing</b>	96
2.1	Steelmaking and pipe manufacturing	
3	<b>Approval</b>	96
3.1	Pipe manufacturing process	
4	<b>Quality of materials</b>	97
4.1	General requirements	
5	<b>Visual, dimensional and non-destructive examinations</b>	97
5.1	General requirements	
6	<b>Rectification of surface defects</b>	97
6.1	Rectification of surface defects by grinding	
6.2	Rectification of surface defects by welding	
7	<b>Condition of supply</b>	97
7.1	General requirements	
8	<b>Hydrostatic test</b>	97
8.1	Testing conditions	



# Table of Content

9	Sampling and testing	98
9.1	Batch composition	
9.2	Sampling	
9.3	Preparation of test specimen	
9.4	Tensile and technological tests	
9.5	Impact test	
9.6	Re-test procedures	
10	Identification and marking	99
10.1	General requirements	
11	Documentation and certification	99
11.1	General requirements	
<b>Section 2</b>	<b>Pipes for Pressure Systems Operating at Ambient Temperature</b>	
1	Requirements	100
1.1	Scope	
1.2	Steel grades	
1.3	Condition of supply	
1.4	Chemical composition	
1.5	Mechanical properties	
1.6	Mechanical and technological tests	
1.7	Non-destructive examination	
<b>Section 3</b>	<b>Pipes for Structural Applications</b>	
1	Requirements	102
1.1	Scope	
1.2	Steel grades	
1.3	Mechanical and technological tests	
1.4	Non-destructive examination	
<b>Section 4</b>	<b>Extra High Strength Steel Pipes for Welded Structure</b>	
1	Requirements	104
1.1	Scope	
1.2	Steel grades	
1.3	Condition of supply	
1.4	Mechanical properties	
1.5	Non-destructive examination	
<b>Section 5</b>	<b>Pipes for High Temperature Service</b>	
1	Requirements	105
1.1	Scope	
1.2	Steel grades	
1.3	Condition of supply	
1.4	Chemical composition	
1.5	Mechanical properties	
1.6	Mechanical properties at elevated temperatures	
1.7	Mechanical and technological tests	
1.8	Non-destructive examination	
<b>Section 6</b>	<b>Ferritic Steel Pipes for Pressure Service at Low Temperature</b>	
1	Requirements	108
1.1	Scope	
1.2	Steel grades	
1.3	Condition of supply	
1.4	Chemical composition	
1.5	Mechanical properties	
1.6	Mechanical and technological tests	
1.7	Non-destructive examination	

# Table of Content

<b>Section 7</b>	<b>Austenitic and Austenitic-Ferritic Stainless Steel Pipes</b>	
1	Requirements	110
1.1	Scope	
1.2	Steel grades	
1.3	Condition of supply	
1.4	Chemical composition	
1.5	Mechanical properties	
1.6	Mechanical and technological tests	
1.7	Non-destructive examination	
1.8	Corrosion tests	
<b>Section 8</b>	<b>Fittings</b>	
1	Requirements	112
1.1	Scope	
1.2	Steel grades	
1.3	Condition of supply	
1.4	Mechanical properties	
1.5	Mechanical and technological tests	
1.6	Non-destructive examination	
1.7	Marking and certification	

---

## Chapter 5 Steel Forgings

<b>Section 1</b>	<b>General Requirements</b>	
1	Scope	114
1.1	General	
2	Manufacturing	114
2.1	Manufacturing process	
3	Approval	115
3.1	Steelmaking	
3.2	Forging process	
4	Quality of materials	115
4.1	General requirements	
5	Chemical composition	115
5.1	General requirements	
6	Heat treatment (including surface hardening and straightening)	116
6.1	General requirements	
7	Mechanical tests	116
7.1	General	
7.2	Individual testing	
7.3	Batch testing	
7.4	Batch testing for rolled products	
7.5	Sampling	
7.6	Preparation of test specimen	
7.7	Tensile test	
7.8	Impact test	
7.9	Hardness test	
7.10	Re-test procedures	
8	Pressure test	118
8.1	General requirements	

# Table of Content

9	Visual and dimensional examination	118
9.1	Visual examination	
9.2	Verification of dimensions	
10	Non-destructive examination	119
10.1	General requirements	
10.2	Magnetic and liquid penetrant examination	
10.3	Ultrasonic examination	
11	Rectification of defects	119
11.1	Rectification of defects by grinding	
11.2	Rectification of defects by welding	
12	Identification and marking	119
12.1	General requirements	
13	Documentation and certification	120
13.1	General requirements	
<b>Section 2</b>	<b>Forgings for Hull, Offshore Structures and Welded Components in General</b>	
1	Requirements	121
1.1	Scope	
1.2	Steel grades	
1.3	Manufacture	
1.4	Condition of supply	
1.5	Chemical composition	
1.6	Mechanical properties	
1.7	Mechanical tests	
1.8	Non-destructive examination	
<b>Section 3</b>	<b>Forgings for Machinery, Shafts and Non-Welded Components in General</b>	
1	Requirements	123
1.1	Scope	
1.2	Steel grades	
1.3	Manufacture	
1.4	Condition of supply	
1.5	Chemical composition	
1.6	Mechanical properties	
1.7	Mechanical tests	
1.8	Non-destructive examination	
<b>Section 4</b>	<b>Forgings for Crankshafts</b>	
1	Requirements	127
1.1	Scope	
1.2	Steel grades	
1.3	Manufacture	
1.4	Condition of supply	
1.5	Chemical and mechanical properties	
1.6	Mechanical tests	
1.7	Non-destructive examination	
<b>Section 5</b>	<b>Forgings for Gearing</b>	
1	Requirements	129
1.1	Scope	
1.2	Steel grades	
1.3	Manufacture	
1.4	Condition of supply	
1.5	Chemical and mechanical properties	
1.6	Mechanical tests for normalised and tempered or quenched and tempered forgings	
1.7	Mechanical tests for surface-hardened forgings	
1.8	Non-destructive examination	

# Table of Content

<b>Section 6</b>	<b>Forgings for Turbines</b>		
1	Requirements		132
1.1	Scope		
1.2	Steel grades, chemical composition and mechanical properties		
1.3	Manufacture		
1.4	Condition of supply		
1.5	Mechanical tests		
1.6	Non-destructive examination		
1.7	Thermal stability test		
<b>Section 7</b>	<b>Forgings for Boilers, Pressure Vessels and Systems</b>		
1	Requirements		134
1.1	Scope		
1.2	Steel grades		
1.3	Manufacture		
1.4	Condition of supply		
1.5	Chemical composition		
1.6	Mechanical properties		
1.7	Mechanical properties at elevated temperature		
1.8	Mechanical tests		
1.9	Non-destructive examination		
<b>Section 8</b>	<b>Ferritic Steel Forgings for Low Temperature Service</b>		
1	Requirements		138
1.1	Scope		
1.2	Steel grades		
1.3	Manufacture		
1.4	Condition of supply		
1.5	Mechanical tests		
1.6	Non-destructive examination		
<b>Section 9</b>	<b>Stainless Steel Forgings</b>		
1	Requirements		139
1.1	Scope		
1.2	Steel grades and relevant properties		
1.3	Manufacture		
1.4	Mechanical tests		
1.5	Non-destructive examination		
1.6	Corrosion tests		

---

## Chapter 6 Steel Castings

<b>Section 1</b>	<b>General Requirements</b>		
1	Scope		141
1.1	General		
1.2	Mass production		
1.3	Other specifications		
1.4	Special requirements		
2	Manufacturing		141
2.1	Steelmaking		
2.2	Flame and arc-air shaping		
2.3	Welding of castings		
3	Approval		142
3.1	Casting process		

# Table of Content

<b>4</b>	<b>Quality of materials</b>	<b>142</b>
	4.1 General requirements	
<b>5</b>	<b>Chemical composition</b>	<b>142</b>
	5.1 General requirements	
<b>6</b>	<b>Heat treatment</b>	<b>142</b>
	6.1 General requirements	
<b>7</b>	<b>Mechanical tests</b>	<b>142</b>
	7.1 General	
	7.2 Individual testing	
	7.3 Batch testing	
	7.4 Preparation of test specimen	
	7.5 Tensile test	
	7.6 Impact test	
	7.7 Hardness test	
	7.8 Re-test procedures	
<b>8</b>	<b>Pressure test</b>	<b>143</b>
	8.1 Testing conditions	
<b>9</b>	<b>Visual and dimensional examination</b>	<b>144</b>
	9.1 Visual examination	
	9.2 Verification of dimensions	
<b>10</b>	<b>Non-destructive examination</b>	<b>144</b>
	10.1 General	
	10.2 Magnetic and liquid penetrant examination	
	10.3 Radiographic examination	
	10.4 Ultrasonic examination	
<b>11</b>	<b>Repair by grinding</b>	<b>144</b>
	11.1 General requirements	
<b>12</b>	<b>Repair by welding</b>	<b>145</b>
	12.1 General requirements	
<b>13</b>	<b>Identification and marking</b>	<b>146</b>
	13.1 General requirements	
<b>14</b>	<b>Documentation and certification</b>	<b>146</b>
	14.1 General requirements	
<b>Section 2</b>	<b>Castings for Hull, Offshore Structures and Welded Components in General</b>	
<b>1</b>	<b>Requirements</b>	<b>147</b>
	1.1 Scope	
	1.2 Steel grades	
	1.3 Manufacture	
	1.4 Chemical composition	
	1.5 Heat treatment	
	1.6 Mechanical properties	
	1.7 Mechanical tests	
	1.8 Non-destructive examination	

# Table of Content

<b>Section 3</b>	<b>Castings for Machinery and Non-Welded Components in General</b>	
1	Requirements	149
1.1	Scope	
1.2	Steel grades	
1.3	Manufacture	
1.4	Chemical composition	
1.5	Heat treatment	
1.6	Mechanical properties	
1.7	Mechanical tests	
1.8	Non-destructive examination	
<b>Section 4</b>	<b>Castings for Crankshafts</b>	
1	Requirements	151
1.1	Scope	
1.2	Steel grades	
1.3	Manufacture	
1.4	Chemical composition	
1.5	Heat treatment	
1.6	Mechanical properties	
1.7	Mechanical tests	
1.8	Non-destructive examinations	
<b>Section 5</b>	<b>Castings for Boilers, Pressure Vessels and Systems</b>	
1	Requirements	152
1.1	Scope	
1.2	Steel grades	
1.3	Manufacture	
1.4	Chemical composition	
1.5	Heat treatment	
1.6	Mechanical properties	
1.7	Mechanical properties at elevated temperature	
1.8	Mechanical tests	
1.9	Non-destructive examination	
<b>Section 6</b>	<b>Ferritic Steel Castings for Low Temperature Service</b>	
1	Requirements	155
1.1	Scope	
1.2	Steel grades	
1.3	Manufacture	
1.4	Chemical composition	
1.5	Heat treatment	
1.6	Mechanical properties	
1.7	Mechanical tests	
1.8	Non-destructive examination	
<b>Section 7</b>	<b>Stainless Steel Castings</b>	
1	Requirements	157
1.1	Scope	
1.2	Steel grades	
1.3	Manufacture	
1.4	Chemical composition	
1.5	Heat treatment	
1.6	Mechanical properties	
1.7	Mechanical tests	
1.8	Non-destructive examination	
1.9	Corrosion tests	

# Table of Content

## Section 8 Stainless Steel Castings for Propellers

1	Requirements	159
1.1	Scope	
1.2	Manufacture	
1.3	Quality of castings	
1.4	Chemical composition	
1.5	Heat treatment	
1.6	Mechanical properties	
1.7	Mechanical tests	
1.8	Definition of skew, severity zones	
1.9	Visual and dimensional examination	
1.10	Non-destructive testing	
1.11	Acceptance criteria for liquid penetrant testing	
1.12	Repair of defects	
1.13	Weld repair	
1.14	Identification and marking	

---

## Chapter 7 Iron Castings

### Section 1 General Requirements

1	Scope	165
1.1	General	
1.2	Mass production	
2	Casting designation	165
2.1	Cast iron grade	
3	Manufacturing	165
3.1	General requirements	
4	Quality of castings	165
4.1	General requirements	
5	Visual, dimensional and non-destructive examination	165
5.1	General requirements	
6	Repair of defects	166
6.1	General requirements	
7	Chemical composition	166
7.1	General requirements	
8	Condition of supply	166
8.1	General requirements	
9	Sampling and testing	166
9.1	General requirements	
10	Identification and marking	166
10.1	General requirements	
11	Documentation and certification	167
11.1	General requirements	

### Section 2 Grey Iron Castings

1	Requirements	168
1.1	Scope	
1.2	Mechanical tests	
1.3	Mechanical properties	



# Table of Content

<b>Section 3</b>	<b>Spheroidal or Nodular Graphite Iron Castings</b>	
1	Requirements	170
1.1	Scope	
1.2	Manufacture and condition of supply	
1.3	Mechanical tests	
1.4	Mechanical properties	
1.5	Metallographic examination	
1.6	Non-destructive examination	

---

## Chapter 8 Copper and Copper Alloys

<b>Section 1</b>	<b>General Requirements</b>	
1	Scope	174
1.1	General	
2	Manufacturing	174
2.1	General requirements	
3	Testing	174
3.1	General requirements	
4	Documentation and certification	174
4.1	General requirements	

<b>Section 2</b>	<b>Copper Alloy Castings</b>	
1	Requirements	175
1.1	Scope	
1.2	Manufacture	
1.3	Condition of supply	
1.4	Chemical composition	
1.5	Mechanical properties	
1.6	Mechanical tests	
1.7	Visual and non-destructive examination	
1.8	Rectification of defective castings	
1.9	Identification and marking	

<b>Section 3</b>	<b>Copper Alloy Castings for Propellers</b>	
1	Requirements	178
1.1	Scope	
1.2	Manufacturing	
1.3	Quality of castings	
1.4	Condition of supply	
1.5	Chemical composition	
1.6	Mechanical properties	
1.7	Sampling and testing	
1.8	Definition of skew, severity zones	
1.9	Visual and dimensional examination	
1.10	Non-destructive testing	
1.11	Acceptance criteria for liquid penetrant testing	
1.12	Repair of defects	
1.13	Weld repair	
1.14	Straightening	
1.15	Identification and marking	

# Table of Content

<b>Section 4</b>	<b>Copper Alloy Pipes</b>	<b>187</b>
1	Requirements	
1.1	Scope	
1.2	Manufacture	
1.3	Condition of supply	
1.4	Chemical composition	
1.5	Mechanical properties	
1.6	Mechanical tests	
1.7	Stress corrosion cracking test	
1.8	Hydrostatic test - Eddy current test	
1.9	Visual and non-destructive examination	
1.10	Rectification of defects	
1.11	Identification and marking	

---

## Chapter 9 Aluminium Alloys

<b>Section 1</b>	<b>General Requirements</b>	<b>191</b>
1	Scope	
1.1	General	
1.2	Other standards	
2	Manufacturing	
2.1	Alloy making and heat treatment processes	
2.2	Quality of material	
2.3	Marking	
2.4	Certification and documentation	
<b>Section 2</b>	<b>Wrought Aluminium Alloy Products (Plates, Bars, Sections and Tubes)</b>	<b>192</b>
1	Requirements	
1.1	Scope	
1.2	Approval	
1.3	Aluminium grades and their temper conditions	
1.4	Chemical composition	
1.5	Mechanical properties	
1.6	Repairs	
1.7	Tolerances on dimensions	
1.8	Tests and examinations	
1.9	Tensile test	
1.10	Drift expansion tests	
1.11	Corrosion tests	
1.12	Re-test procedures	
1.13	Hydrostatic test	
<b>Section 3</b>	<b>Rivets</b>	<b>198</b>
1	Requirements	
1.1	Scope	
1.2	Chemical composition	
1.3	Heat treatment	
1.4	Test material	
1.5	Mechanical tests	
1.6	Identification	
1.7	Certification	

# Table of Content

<b>Section 4</b>	<b>Transition Joints</b>	
1	Requirements	200
1.1	Scope	
1.2	Manufacturing	
1.3	Visual and non-destructive examination	
1.4	Testing	
<b>Section 5</b>	<b>Aluminium Alloy Castings</b>	
1	Requirements	201
1.1	Scope	
1.2	Aluminium grades	
1.3	Manufacturing	
1.4	Chemical composition	
1.5	Mechanical properties	
1.6	Mechanical tests	

---

## Chapter 10 Equipment for Mooring and Anchoring

<b>Section 1</b>	<b>Anchors for Ships</b>	
1	Requirements	205
1.1	Scope	
1.2	Design	
1.3	Materials	
1.4	Manufacturing	
1.5	Tests and examination	
1.6	Identification, marking and certification	
<b>Section 2</b>	<b>Stud Link Chain Cables and Accessories for Ships</b>	
1	Requirements	211
1.1	Scope	
1.2	Chain cable grades	
1.3	Approval of chain cable manufacturers	
1.4	Rolled steel bars	
1.5	Forged steels	
1.6	Cast steels	
1.7	Materials for studs	
1.8	Design and manufacture of chain cables and accessories	
1.9	Testing of finished chain cables	
1.10	Testing of accessories	
<b>Section 3</b>	<b>Studless Chain Cables for Ships</b>	
1	Requirements	221
1.1	Scope	
1.2	Manufacturing	
1.3	Studless chain cable grades	
1.4	Short and long links	
1.5	Materials for studless chain cables	
1.6	Testing of finished chain cables	

# Table of Content

## Section 4 Offshore Mooring Chain Cables and Accessories

<b>1</b>	<b>General requirements</b>	<b>224</b>
1.1	Scope	
1.2	Chain grades	
1.3	Approval of chain manufacturers	
1.4	Approval of quality system at chain and accessory manufacturers	
1.5	Approval of steel mills - Rolled bar	
1.6	Approval of forges and foundries - Accessories	
<b>2</b>	<b>Materials</b>	<b>227</b>
2.1	Scope	
2.2	Rolled steel bars	
2.3	Forged steel	
2.4	Cast steel	
2.5	Materials for studs	
<b>3</b>	<b>Design and manufacture</b>	<b>232</b>
3.1	Design	
3.2	Chain cable manufacturing process	
<b>4</b>	<b>Testing and inspection of finished chain</b>	<b>236</b>
4.1	General	
4.2	Proof and break load tests	
4.3	Dimensions and dimensional tolerances	
4.4	Mechanical tests	
4.5	Non-destructive examination after proof load testing	
4.6	Retest, rejection and repair criteria	
4.7	Marking	
4.8	Documentation	
<b>5</b>	<b>Testing and inspection of accessories</b>	<b>239</b>
5.1	General	
5.2	Proof and break load tests	
5.3	Dimensions and tolerances on dimensions	
5.4	Mechanical tests	
5.5	Non-destructive examination after proof load testing	
5.6	Test failures	
5.7	Marking	
5.8	Documentation	
<b>6</b>	<b>Chafing chain for single point mooring arrangements</b>	<b>242</b>
6.1	Scope	
6.2	Approval of manufacturing	
6.3	Materials	
6.4	Design, manufacturing, testing and certification	

## Section 5 Steel Wire Ropes

<b>1</b>	<b>Requirements</b>	<b>243</b>
1.1	Scope	
1.2	Manufacturing	
1.3	Types of ropes	
1.4	Sampling and testing	
1.5	Identification marking and certification	

## Section 6 Fibre Ropes

<b>1</b>	<b>Requirements</b>	<b>253</b>
1.1	Scope	
1.2	Design	
1.3	Sampling and testing	
1.4	Marking	

## Chapter 11 Type Approval of Welding Consumables

### Section 1 General Requirements

1	Scope	256
	1.1 General	
2	Grading and designation	256
	2.1 General	
	2.2 Consumables for C and C-Mn steels and for Q-T steels	
	2.3 Consumables for Mo and Cr-Mo steels	
	2.4 Consumables for Ni steels for low temperature applications	
	2.5 Consumables for austenitic and austenitic-ferritic (duplex) stainless steels	
	2.6 Consumables for aluminium alloys	
	2.7 Additional symbols	
3	Approval procedure	257
	3.1 Request for approval	
	3.2 Quality of manufacturing	
	3.3 Approval tests	
	3.4 Certification	
	3.5 Annual inspections and tests	
	3.6 Manufacturer's responsibilities	
	3.7 Firms with several workshops or dealers	
	3.8 Different brand names	
	3.9 Changes in grading	
	3.10 Additional tests	
4	Preparation and welding of test assemblies	259
	4.1 Base material	
	4.2 Welding conditions and type of current	
	4.3 Post-weld heat treatment	
5	Mechanical tests	259
	5.1 General	
	5.2 Tensile tests	
	5.3 Transverse bend tests	
	5.4 Side bend tests	
	5.5 Longitudinal bend tests	
	5.6 Impact tests	
6	Test samples for checking the chemical composition of deposited weld metal	260
	6.1 General requirements	
7	Re-test procedures	261
	7.1 General	
	7.2 Tensile and bend tests	
	7.3 Charpy V-notch impact test	

### Section 2 Covered Electrodes for Manual Metal Arc Welding of C and C-Mn Steels

1	Requirements	262
	1.1 Scope	
	1.2 Approval tests	
	1.3 Tests for checking the mechanical pro-perties	
	1.4 Tests for checking the hydrogen content	
	1.5 Fillet weld test assemblies	
	1.6 Annual control tests	

# Table of Content

<b>Section 3</b>	<b>Covered Electrodes for Gravity or Contact Welding</b>	
1	Requirements	269
1.1	Scope	
1.2	Approval tests	
1.3	Annual control tests	
<b>Section 4</b>	<b>Covered Electrodes for Deep Penetration Manual Welding of C and C-Mn Steels</b>	
1	Requirements	270
1.1	Scope	
1.2	Approval tests	
1.3	Annual control tests	
<b>Section 5</b>	<b>Flux-Wire Combination for Submerged Arc Welding of C and C-Mn Steels</b>	
1	Requirements	273
1.1	Scope	
1.2	Approval tests	
1.3	Annual control tests	
<b>Section 6</b>	<b>Flux-Wire Combinations for One Side Submerged Arc Welding of Butt-Joints of C and C-Mn Steels</b>	
1	Requirements	279
1.1	Scope	
1.2	Designation	
1.3	Approval tests	
<b>Section 7</b>	<b>Wires and Wire-Gas Combination for Semiautomatic Welding of C and C-Mn Steels</b>	
1	Requirements	280
1.1	Scope	
1.2	Type of wires	
1.3	Shielding gases	
1.4	Designation	
1.5	Information and documentation to be submitted	
1.6	Approval tests	
1.7	Annual control tests	
<b>Section 8</b>	<b>Wires and Wire-Gas Combinations for Automatic Welding of C and C-Mn Steels</b>	
1	Requirements	285
1.1	Scope	
1.2	Designation	
1.3	Approval tests	
1.4	Annual control tests	
<b>Section 9</b>	<b>Consumables for Welding C and C-Mn Steels with Electrode or Electroslag Process</b>	
1	Requirements	288
1.1	Scope	
1.2	Information and documentation to be submitted	
1.3	Approval tests	
1.4	Annual control tests	

# Table of Content

<b>Section 10</b>	<b>Consumables for Welding Extra High Strength Steels</b>	
1	Requirements	291
1.1	Scope	
1.2	Approval tests	
1.3	Test requirements	
1.4	Annual control tests	
<b>Section 11</b>	<b>Consumables for Welding EH47 Steel and Crack Arrest Steel EH47CAS</b>	
1	Requirements	293
1.1	Scope	
1.2	Approval tests	
1.3	Test requirements	
1.4	Annual control tests	
<b>Section 12</b>	<b>Consumables for Welding Mo and Cr-Mo Steels</b>	
1	Requirements	294
1.1	Scope	
1.2	Approval tests	
1.3	Test requirements	
1.4	Annual control tests	
<b>Section 13</b>	<b>Consumables for Welding Ni Steels for Low Temperature Applications</b>	
1	Requirements	296
1.1	Scope	
1.2	Approval tests	
1.3	Tests requirements	
1.4	Annual control tests	
<b>Section 14</b>	<b>Consumables for Welding Cr-Ni Austenitic and Austenitic-Ferritic Stainless Steels</b>	
1	Requirements	298
1.1	Scope	
1.2	Approval tests	
1.3	Tests requirements	
1.4	Annual control tests	
<b>Section 15</b>	<b>Consumables for Welding Aluminium Alloys</b>	
1	Requirements	301
1.1	Scope	
1.2	Approval tests	
1.3	Test requirements	
1.4	Annual control tests	

---

## Chapter 12 Welding

### Section 1 General Requirements

1	Scope	306
1.1	General	
2	Fabrication by welding	306
2.1	General	
2.2	Approval	
2.3	Type of joints, edge preparations and size	
2.4	Welding execution and control	



# Table of Content

<b>Section 2</b>	<b>General Requirements for Qualification of Welding Procedures</b>	
1	Requirements	308
	1.1 Scope	
	1.2 Welding procedure	
<b>Section 3</b>	<b>Welding Procedures for Steel Ship Hull and Welded Structures</b>	
1	General requirements	310
	1.1 Approval	
2	Welding procedure qualification tests for C and C-Mn steels for ship hull and other welded structures in general	310
	2.1 Plates butt weld with full penetration	
	2.2 T butt joints in plates	
	2.3 Plates fillet weld	
	2.4 Pipes butt weld with full penetration	
	2.5 Re-testing	
	2.6 Range of approval	
3	Welding procedures for extra high strength steels	323
	3.1 Requirements	
4	Welding procedures for EH47 and crack arrest steels	323
	4.1 General	
	4.2 Parent metal	
	4.3 Impact tests	
	4.4 Hardness tests	
	4.5 Brittle fracture initiation test	
<b>Section 4</b>	<b>Welding Procedures for other Ship Applications</b>	
1	General requirements	324
	1.1 Approval	
2	Welding procedures for cargo tanks and process pressure vessels of liquefied gas carriers	324
	2.1 Requirements	
3	Welding procedures for fuel tanks and process pressure vessels of gas fuelled ships	324
	3.1 Requirements	
4	Welding procedures for Cr-Ni austenitic and austenitic-ferritic stainless steels for application with chemicals	324
	4.1 Requirements	
5	Approval of welding procedures for copper alloys	325
	5.1 Pipes butt weld	
	5.2 Re-testing	
	5.3 Range of approval	
6	Approval of welding procedure for repair of propeller castings	326
	6.1 Scope	
	6.2 Assembly of test piece	
	6.3 Examination and tests	
	6.4 Range of approval	
7	Approval of welding procedure for cladding	329
	7.1 Requirements	
<b>Section 5</b>	<b>Welding Procedures for Aluminium Alloys</b>	
1	General requirements	330
	1.1 Approval	

# Table of Content

	2		330
		2.1	Plates butt weld
		2.2	Plates fillet weld
		2.3	Pipes butt weld with full penetration
		2.4	Re-testing
		2.5	Range of approval
<b>Section 6</b>	<b>Welding Procedures for Offshore Structures and Equipment</b>		
	1	General requirements	335
	1.1	Approval	
<b>Section 7</b>	<b>Welding Procedures for CO2 Laser</b>		
	1	General requirements	336
	1.1	Approval	
	2	Welding procedures for CO2 laser	336
	2.1	Scope	
	2.2	General requirements	
	2.3	Welding procedure specification	
	2.4	Parent metal	
	2.5	Welding consumables	
	3	Approval of welding procedure	337
	3.1	General	
	3.2	Assembly and welding	
	4	Non-destructive examinations	337
	4.1	General	
	5	Plates butt welds	337
	5.1	Assembly	
	5.2	Examinations and tests	
	5.3	Tensile tests	
	5.4	Bend tests	
	5.5	Impact tests	
	5.6	Hardness measurements	
	5.7	Metallographic examination	
	6	T joint weld procedure test	341
	6.1	Assembly	
	6.2	Examinations and tests	
	7	Re-testing	342
	7.1	Non-destructive and destructive tests	
	8	Range of approval	342
	8.1	Parent metal	
	8.2	Thickness	
	8.3	Edge preparation and surface condition	
	8.4	Joint type, bevel	
	8.5	Welding machine	
	8.6	Welding parameters	
<b>Section 8</b>	<b>Welding Procedures for Friction Stir Welding</b>		
	1	Requirements	344
	1.1	Scope	
	1.2	Welding procedure	
	1.3	Range of approval	

# Table of Content

---

## Chapter 13 Other Products

<b>Section 1</b>	<b>Approval of Over Weldable Shop Primers</b>	
1	Scope	347
	1.1 General	
2	Information and documentation to be submitted	347
	2.1 General	
3	Approval tests	347
	3.1 Base material	
	3.2 Filler metal	
	3.3 Type and dimension of test samples	
	3.4 Number of samples required	
	3.5 Preparation of test samples	
	3.6 Test requirements	
	3.7 Re-tests	
4	Certification	348
	4.1 Certification	
	4.2 Renewal	
<b>Section 2</b>	<b>Side Scuttles, Windows and their Glass Panes</b>	
1	Requirements	349
	1.1 Scope	
	1.2 Manufacture	
	1.3 Testing	
	1.4 Identification and marking	
<b>Section 3</b>	<b>Pressure Bottles</b>	
1	Requirements	353
	1.1 Scope	
	1.2 Manufacture	
	1.3 Testing	
	1.4 Identification, marking and certification	

---

## Chapter 14 Advanced Non-Destructive Techniques

<b>Section 1</b>	<b>Requirements</b>	
1	Scope	356
	1.1 General	
	1.2 Weld joints	
	1.3 Testing methods	
2	Acronyms	357
	2.1 Definitions	
3	Supervision of personnel involved in ANDT operations	357
	3.1 General requirements	
4	Technique and procedure qualification	357
	4.1 Documentation to be submitted	
	4.2 Software simulation	
	4.3 Procedure qualification test	
	4.4 Procedure approval	
	4.5 On-site review	

# Table of Content

<b>5</b>	<b>Surface condition</b>	<b>358</b>
	5.1 Requirements	
<b>6</b>	<b>Testing requirements</b>	<b>358</b>
	6.1 General requirements	
	6.2 Phased array ultrasonic testing (PAUT)	
	6.3 Time of flight diffraction (TOFD)	
	6.4 Digital radiography (RT-D)	
<b>7</b>	<b>Acceptance levels</b>	<b>362</b>
	7.1 General requirements	
	7.2 Phased array ultrasonic testing (PAUT)	
	7.3 Time of flight diffraction (TOFD)	
	7.4 Digital radiography (RT-D)	
<b>8</b>	<b>Reporting</b>	<b>363</b>
	8.1 Requirements	
<b>9</b>	<b>Unacceptable indications and repairs</b>	<b>365</b>
	9.1 Requirements	

# NR216

## Rules on Materials and Welding

---

### CHAPTER 1

## GENERAL REQUIREMENTS

---

- Section 1      Manufacture, Inspection, Certification
- Section 2      Correspondence with Former Edition of the Rules

# Section 1 Manufacture, Testing, Certification

## 1 General

### 1.1 Scope

**1.1.1** These Rules specify the requirements for the manufacture, testing and certification of steel and iron products, non-ferrous metals, welding consumables, welding procedures, various finished products and equipment such as propellers, pressure bottles, anchors, chain cables, ropes and sidescuttles, used for the construction or repair of Units which are surveyed for classification purposes.

The requirements of Chapter 1 and Chapter 2 are also applicable, as appropriate, to products covered by other relevant Society's Rules.

**1.1.2** In addition to these Rules, the requirements given for certain materials, procedures and products in the other relevant Society's Rules or specified by the Society on the reviewed drawings, are also applicable, where appropriate.

**1.1.3** Products subject to the requirements of these Rules and the relevant testing operations are those laid down in the relevant Rules of the Society dealing with the design, survey at works and testing of products, unless otherwise specified.

**1.1.4** Products with properties departing appreciably from those covered by these Rules and other relevant Society's Rules may be used with the approval of the Society.

### 1.2 Other specifications

**1.2.1** Products complying with international, national or proprietary specifications may be accepted by the Society, provided such specifications give reasonable equivalence to the requirements of these Rules and other relevant Society's Rules or are approved for a specific application.

Such products, when accepted, are designated by their standard identification or as agreed at the time of the approval.

Unless otherwise agreed, survey and certification of products complying with other specifications are to be carried out in accordance with the requirements of these Rules and other relevant Society's Rules.

### 1.3 Information to be supplied by the purchaser

**1.3.1** The purchaser is to provide the Manufacturer with the information necessary to ensure that products are tested in accordance with these Rules and other relevant Society's Rules; optional or additional conditions are also to be clearly indicated.

## 2 Manufacture and quality

### 2.1 General

#### 2.1.1 Manufacture

Manufacturers and their individual works are to be recognised by the Society for the type of products fabricated on a case-by-case basis or through recognition scheme given in NR320.

To this end plants, production and treatment procedures, testing machines, laboratories for analyses, internal control systems and personnel qualification are to be suitable in the opinion of the Society.

Manufacturing procedures and techniques are to be such as to reasonably ensure constant compliance of the product with the requirements.

Where tests and analyses are performed by external laboratories or third parties, these are to be recognised by the Society on a case-by-case basis or through recognition scheme given in NR320.

#### 2.1.2 Approval

Depending on the type and importance of the products being supplied, the relevant manufacturing process may be required to be approved and approval tests performed for the purpose.

When approval of the manufacturing process is required, such condition is specified in the rule requirements relevant to the various products.

The provisions for the approval of Manufacturers are given in the document NR480 "Approval of the manufacturing process of metallic materials".

#### 2.1.3 Responsibility

Irrespective of the interventions of Surveyors, the Manufacturer is entirely and solely responsible for compliance of the supplied products with the stipulated requirements.

The Society assumes no liability by its interventions in respect of the compliance of a tested product with the stipulated regulations and requirements.

Where, in the course of manufacture or after supply, a product is found not to be in compliance with the requirements or to present unacceptable defects, it will be rejected, irrespective of any previous satisfactory test results.

### 2.2 Chemical composition

**2.2.1** The chemical composition is to be determined and certified, as a rule, by the Manufacturer using ladle sampling analysis. The laboratory is to be adequately equipped and the analyses are to be performed by qualified personnel.

**2.2.2** The analyses of the Manufacturer are generally accepted subject to occasional checks, if required by the Surveyor. When checks on the product are required, they are to be performed and the results evaluated in accordance with recognised standards.

### 2.3 Condition of supply

**2.3.1** Unless otherwise agreed, the products are to be supplied in the finished condition as per rules, including heat treatment if required.

Heat treatment is to be carried out in suitable and efficient furnaces, fitted with appropriate means for temperature control and recording. Sufficient thermocouples are to be connected to the furnace charge to measure and record that its temperature is adequately uniform unless the temperature uniformity of the furnace is verified at regular intervals. The manufacturer is to maintain records of heat treatment identifying the furnace used, furnace charge, date, temperature and time at temperature. The records are to be presented to the surveyor on request.

The furnaces employed are to have a size sufficient to allow a uniform increase in temperature up to the required value of the entire part to be heat treated. In the case of very large parts, alternative systems proposed are to be agreed by the Society.

### 2.4 Identification of products

**2.4.1** In the course of manufacturing, inspection and testing, the identification of the various products in respect of their origin is to be ensured as required.

To this end the Surveyor is to be given all facilities for tracing the products when required.

## 3 Survey and testing

### 3.1 General conditions

**3.1.1** As far as practicable the inspections and tests are to be carried out at the Manufacturer's works before delivery.

If the necessary facilities are not available at the Manufacturer's works, the testing is to be carried out at a testing laboratory agreed with the Society.

**3.1.2** Where the testing is allowed to be carried out or completed at works other than the Manufacturer's it is in any case to be possible to trace back with certainty to the documentation of the origin.

**3.1.3** Interested parties are to apply for Society's intervention in adequate time.

Prior to the survey, the Manufacturer is to provide the Surveyor with details of the orders, technical specifications and any special condition additional to the rule requirements.

**3.1.4** The Surveyors are to have free access to all departments involved in production, collection of test samples, internal control and, in general, all operations concerning the manufacturing, examination and testing.

They are to be supplied with the information necessary to assess whether production and tests are performed according to the rule requirements.

**3.1.5** The tests and checks required by the Rules are to be carried out in the presence of the Surveyors or, when expressly agreed with the Society, in the presence of the person responsible for internal control, specially delegated for this purpose.

The survey activities may be delegated to the Manufacturer under the conditions given in [3.2].

**3.1.6** The tests required are to be performed by qualified personnel in accordance with the Society's Rules or, with recognised national or international standards, as appropriate.

The testing and measuring equipment is to be adequate, maintained in proper condition and regularly calibrated, as required; the record of such checks is to be kept up-to-date and made available to the Surveyor.



### **3.2 Alternative survey scheme (known as BV Mode I)**

**3.2.1** Alternative procedures to the systematic intervention of the Surveyor for testing may be adopted by Manufacturers specially recognised by the Society for the purpose in accordance with NR320 "Certification Scheme of Materials and Equipment for the Classification of Marine Units".

Such alternative survey schemes, which are determined by taking into account the type of product, its mass production and the effectiveness of the certified Quality System implemented in the workshop, allow the testing operations indicated in these Rules and other relevant Society's Rules to be totally or partially carried out by the Manufacturer without the presence of the Surveyor.

### **3.3 Sampling for mechanical tests**

**3.3.1** The test samples are to be selected by the Surveyor or by a responsible person from the Manufacturer's staff, specially delegated, and are to be suitably marked for identification purposes.

**3.3.2** The test samples are to be representative of the unit or lot of material which they are relevant to and are therefore also to have been subjected to the same heat treatment as the products except when a different procedure is agreed with the Society.

**3.3.3** For the purpose of test sampling the following definitions apply:

- a) unit: single forging, casting, plate, tube or other single product
- b) rolled unit: product rolled from the same slab or billet or, when rolling proceeds directly from ingots, from the same ingot
- c) batch: number of similar units or rolled units presented as a group for acceptance testing, on the basis of the tests to be carried out on the test sample
- d) sample: a sufficient quantity of material taken from the unit, rolled unit or batch, for the purpose of producing one or more test specimens
- e) test specimens: part of sample with specified dimensions and conditions for submission to a given test.

### **3.4 Mechanical tests**

**3.4.1** The mechanical tests are to be carried out in the presence of the Surveyor unless otherwise agreed; see [3.2].

**3.4.2** For the check of the mechanical properties of the material, test methods and specimens in compliance with the requirements of Chapter 2 are to be used.

**3.4.3** The type of tests, the number and direction of the test specimens and the results of the tests are to comply with the requirements relevant to the type of product, as indicated in the various Articles.

### **3.5 Re-test procedures**

#### **3.5.1 General**

Where the unsuccessful outcome of any test is attributable to defective machining of the test specimen and/or to improper test procedure, the negative result is disregarded and the test repeated, in correct conditions, on a substitute test specimen.

#### **3.5.2 Rejection or reconsideration**

Where unsatisfactory results are obtained from re-tests representative of one lot of material, the unit from which the test specimens are taken is rejected.

The remainder of the lot may, at the discretion of the Surveyor, be reconsidered by performing the required tests on at least two different units; for acceptance, both the results of the new tests are to satisfy the requirements.

Otherwise, upon agreement with the Surveyor, the individual units composing the lot may be tested individually and those found satisfactory may be accepted.

The Manufacturer may resubmit for testing previously rejected material, after a suitable heat treatment or reheat treatment, or resubmit it under a different grade.

The Surveyor is to be notified of such circumstances.

Unless otherwise agreed by the Surveyor, only one new heat treatment is permitted for material which has already been heat treated.

### **3.6 Visual, dimensional and non-destructive examinations**

#### **3.6.1 General**

The products are to be subjected to:

- a) visual examination
- b) dimensional check
- c) non-destructive examination, when applicable.

The above operations are to be carried out on products in appropriate conditions under the responsibility of the Manufacturer and are to be witnessed or repeated in the presence of the Surveyor when required.

When, following examinations and tests, there are grounds to presume that a product may be defective, the Manufacturer is obliged, for the purpose of acceptance, to demonstrate its suitability using procedures deemed necessary.

### 3.6.2 Visual examination

Visual examination is to be carried out by the manufacturer. A general examination is to be carried out by the surveyor at his discretion on each product tested individually, and, at random on products tested by batch.

### 3.6.3 Dimensional check

The dimensional checks and verification of compliance with approved drawings are the responsibility of the manufacturer. Some checks are to be made in presence of the Surveyor, as deemed necessary, solely for those parts subject to approval, or where expressly required in these Rules or other parts of the relevant Society's Rules.

### 3.6.4 Non-destructive examination

The non-destructive examination (also called non-destructive testing) is to be performed by the shipbuilder, manufacturer or its subcontractors in accordance with these requirements.

Non-destructive examination is to be performed by skilled and qualified personnel, using calibrated equipment of suitable type and according to approved procedures, recognized standards and the requirements of the Society.

In case of non-destructive testing carried out by an independent company from the manufacturer or shipyard, such company has to comply with the requirements set out in NR669 "Recognition of non-destructive testing suppliers".

It is the shipbuilder's or manufacturer's responsibility to ensure that testing specifications and procedures are adhered to during the construction and the report is to be made available to the Society on the findings made by the non-destructive testing.

The Manufacturer's laboratory or other organisation responsible for the non-destructive examination is required to issue, on its own responsibility, a certificate illustrating the results and, where requested, an opinion concerning the acceptability of the product; in the latter case, the certificate is to be countersigned by the Manufacturer.

As a general rule, the Society's surveyor may require to witness the testing.

### 3.6.5 Qualification of personnel involved in non-destructive examination

The Shipbuilder, manufacturer or its subcontractor is responsible for the qualification and preferably 3rd party certification of its supervisors and operators to a recognised certification scheme based on ISO 9712:2012.

Personnel qualification to an employer based qualification scheme as e.g. SNT-TC-1A, 2016 or ANSI/ASNT CP-189, 2016 may be accepted if the Shipbuilder, manufacturer or its subcontractor written practice is reviewed and found acceptable by the Society. The Shipbuilder, manufacturer or its subcontractor written practice shall as a minimum, except for the impartiality requirements of a certification body and/or authorised body, comply with ISO 9712:2012.

The supervisors' and operators' certificates and competence shall comprise all industrial sectors and techniques being applied by the Shipbuilder, manufacturer or its subcontractor. Level 3 personnel shall be certified by an accredited certification body.

The operator carrying out the NDT and interpreting indications, shall as a minimum, be qualified and certified to Level 2 in the NDT method(s) concerned.

However, operators only undertaking the gathering of data using any NDT method and not performing data interpretation or data analysis may be qualified and certified as appropriate, at level 1.

The operator shall have adequate knowledge of materials, weld, structures or components, NDT equipment and limitations that are sufficient to apply the relevant NDT method for each application appropriately.

### 3.6.6 Advanced non-destructive examination

Advanced non-destructive examination (testing) such as Phased Array Ultrasonics, Time of Flight Diffraction and Digital Radiography are covered by Chapter 14.

## 3.7 Repairs of defects

**3.7.1** Small surface defects may be suitably removed by grinding or other appropriate means, provided that the dimensional tolerances, prescribed for the various products in the relevant Articles, are complied with.

The repaired zone is to be found free from defects and to be acceptable in the opinion of the Surveyor.

**3.7.2** Repairs by welding may be accepted only where this is not in contrast with the requirements applicable to the product, and provided that they are deemed suitable in connection with the material, extent of defects and welding procedure.

The repair procedure is to be previously agreed upon with the Surveyor.

## 4 Identification and certification

### 4.1 Identification and marking

#### 4.1.1 General

A detailed record of the products to be tested is to be submitted to the Surveyor with indication of the necessary data, as applicable:

- a) name of purchaser and order number
- b) hull number or destination
- c) number, size and mass of parts or batches
- d) cast number and chemical composition
- e) part reference number, detail of manufacturing process and heat treatment
- f) condition of supply.

#### 4.1.2 Manufacturer's marking

Products, which have satisfactorily undergone the required examination and tests are to be appropriately marked by the Manufacturer in at least one easily accessible location.

The marking is to contain all necessary indications, as specified in the Articles relevant to the various products, and is to correspond to the content of the survey documentation.

The marks are to be stamped, as a rule, by means of brands, except when products could be impaired by such a system. When paints or other reliable alternatives are adopted, adequate duration of marking is to be ensured.

For small pieces contained in effective containers, as well as bars and sections of modest weight, adequately bound in bundles, the marks are transferred to the container, label or top item of each bundle to the Surveyor's satisfaction.

#### 4.1.3 Marking with the Society's brand

The products found satisfactory in accordance with the Rules and other relevant Society's Rules are to be marked with the Society's brand Ⓢ in the presence of the Surveyor unless otherwise agreed between Manufacturer and Surveyor.

All other additional marks required are specified in the applicable Articles depending on the products (e.g. name or initials of Manufacturer, material, grade and cast number, code for calendar year, running file number and code of the local office survey, Surveyor's personal brand, test pressure as statement of hydrostatic test).

#### 4.1.4 Society marking for incomplete survey

Whenever a product is dispatched for delivery or is to be marked without undergoing all the examinations and tests required (whether by the provisions of these Rules or those of other relevant Society's Rules), the Society's brand Ⓢ will be replaced by the Society's mark Ⓢ for incomplete survey.

The testing documents are to contain clear indications of all outstanding examinations and tests and specify the reason why they have not been performed.

Upon satisfactory completion of all required examinations and tests, the product is to be stamped with the Society's brand Ⓢ.

#### 4.1.5 Invalidation of Society's brand

When a product already marked with one of the Society's stamps is found not to be in compliance with the requirements and is therefore rejected, the Society's brand is to be invalidated by punching them.

The Surveyors may request to check the invalidation effected.

Any repairs after the product is tested are subject to the prior consent of the Society; failing this, the validity of the original testing will automatically expire and the original testing marks are to be invalidated by the interested parties.

#### 4.1.6 Society's brand for alternative survey scheme

In the case of admission to an alternative survey scheme, the marking with the Society's brand may be delegated to the Manufacturer, who will be supplied with the special brand Ⓢ to be used for this purpose.

## 4.2 Documentation and certification

### 4.2.1 Society's certificate

For products tested with satisfactory results, the Society issues a certificate signed by the Surveyor stating that the products have been tested in accordance with the Society's Rules.

This certificate is identified by the letter C for ease of reference in the various relevant Society's Rules.

A certificate issued by the Manufacturer is to be attached to the Society's certificate and is to include, as applicable, the following particulars:

- a) Manufacturer's name
- b) purchaser's name, order number and hull number
- c) description of the product, dimensions and weight
- d) results of all specified inspections and tests
- e) identification and testing marks stamped on the products.

In the case of testing of materials, the following particulars are also to be included:

- a) identification of specification or grade of material
- b) identification of the heat and relevant chemical analysis
- c) supply condition and details of heat treatment, including temperatures and holding times
- d) working and manufacturing procedure (for rolled products intended for hull, boilers and pressure vessels only)
- e) declaration that the material has been made by an approved process, as applicable, and that it has been subjected to the tests required by the Rules with satisfactory results.

For products manufactured in large quantities and tested by heats or by lot, the Manufacturer is to further state, for the individual supplies, that the products have been produced according to the Society's Rules.

### 4.2.2 Society's certificate for alternative survey scheme

For products covered by the alternative survey scheme, unless otherwise stated in the admission to the alternative survey scheme, the Manufacturer is to issue a Certificate of Conformity on the appropriate Society form.

This certificate is identified by the letter CA (certificate for alternative survey) for ease of reference in the various Society's Rules.

The certificate issued by the Manufacturer and including all the information required in [4.2.1] is to be attached to the (CA) certificate.

The certificate is to be submitted to the Society for endorsement according to the procedures stated in the agreement for the alternative survey scheme.

### 4.2.3 Works' certificates

For products which in accordance with the relevant rules may be accepted only on the basis of a certificate of conformity issued by the Manufacturer, stating the results of the tests performed, such certificate is to contain the information required under [4.2.1], as applicable.

This certificate of conformity is identified by the letter W (works' certificate) for ease of reference in the various parts of the Rules.

For particular products it may be accepted that the tests or examinations are carried out by the Manufacturer not on the product supplied, but on the current production.

This particular certificate of conformity is identified by the letter R (report) for ease of reference in the various Society's Rules.

# Section 2 Correspondence with Former Edition of the Rules

## 1 Table of correspondence

### 1.1 Table

1.1.1 Tab 1 provides correspondences between the provisions of the current edition of the Rules on Materials and Welding for the Classification of Marine Units and former edition dated July 2021

**Table 1 : Correspondence between former edition (July 2021) and current edition of NR216**

CHAPTER 1 former edition July 2021 to current edition					
July 2021	Current edition	July 2021	Current edition	July 2021	Current edition
Ch 1, Sec 1	Sec 1	Ch 1, Sec 2, [3]	Ch 2, Sec 3	Ch 1, Sec 2, [6]	Ch 2, Sec 6
–	Sec 2	Ch 1, Sec 2, [4]	Ch 2, Sec 4	Ch 1, Sec 2, [7]	Ch 2, Sec 6
Ch 1, Sec 2, [1]	Ch 2, Sec 1	Ch 1, Sec 2, [5]	Ch 2, Sec 5	Ch 1, Sec 2, [8]	Ch 2, Sec 7
Ch 1, Sec 2, [2]	Ch 2, Sec 2				

CHAPTER 2 former edition July 2021 to current edition					
July 2021	Current edition	July 2021	Current edition	July 2021	Current edition
Ch 2, Sec 1, [1]	Ch 3, Sec 1	Ch 2, Sec 2, [3]	Ch 4, Sec 3	Ch 2, Sec 3, [8]	Ch 5, Sec 8
Ch 2, Sec 1, [2]	Ch 3, Sec 2	Ch 2, Sec 2, [4]	Ch 4, Sec 4	Ch 2, Sec 3, [9]	Ch 5, Sec 9
Ch 2, Sec 1, [3]	Ch 3, Sec 3	Ch 2, Sec 2, [5]	Ch 4, Sec 5	Ch 2, Sec 4, [1]	Ch 6, Sec 1
Ch 2, Sec 1, [4]	Ch 3, Sec 4	Ch 2, Sec 2, [6]	Ch 4, Sec 6	Ch 2, Sec 4, [2]	Ch 6, Sec 2
Ch 2, Sec 1, [5]	Ch 3, Sec 5	Ch 2, Sec 2, [7]	Ch 4, Sec 7	Ch 2, Sec 4, [3]	Ch 6, Sec 3
Ch 2, Sec 1, [6]	Ch 3, Sec 6	Ch 2, Sec 2, [8]	Ch 4, Sec 8	Ch 2, Sec 4, [4]	Ch 6, Sec 4
Ch 2, Sec 1, [7]	Ch 3, Sec 7	Ch 2, Sec 3, [1]	Ch 5, Sec 1	Ch 2, Sec 4, [5]	Ch 6, Sec 5
Ch 2, Sec 1, [8]	Ch 3, Sec 8	Ch 2, Sec 3, [2]	Ch 5, Sec 2	Ch 2, Sec 4, [6]	Ch 6, Sec 6
Ch 2, Sec 1, [9]	Ch 3, Sec 9	Ch 2, Sec 3, [3]	Ch 5, Sec 3	Ch 2, Sec 4, [7]	Ch 6, Sec 7
Ch 2, Sec 1, [10]	Ch 3, Sec 11	Ch 2, Sec 3, [4]	Ch 5, Sec 4	Ch 2, Sec 4, [8]	Ch 6, Sec 8
Ch 2, Sec 1, [11]	Ch 3, Sec 12	Ch 2, Sec 3, [5]	Ch 5, Sec 5	Ch 2, Sec 5, [1]	Ch 7, Sec 1
Ch 2, Sec 2, [1]	Ch 4, Sec 1	Ch 2, Sec 3, [6]	Ch 5, Sec 6	Ch 2, Sec 5, [2]	Ch 7, Sec 2
Ch 2, Sec 2, [2]	Ch 4, Sec 2	Ch 2, Sec 3, [7]	Ch 5, Sec 7	Ch 2, Sec 5, [3]	Ch 7, Sec 3

CHAPTER 3 former edition July 2021 to current edition					
July 2021	Current edition	July 2021	Current edition	July 2021	Current edition
Ch 3, Sec 1, [1]	Ch 8, Sec 1	Ch 3, Sec 2, [1]	Ch 9, Sec 1	Ch 3, Sec 2, [5]	Ch 9, Sec 5
Ch 3, Sec 1, [2]	Ch 8, Sec 2	Ch 3, Sec 2, [2]	Ch 9, Sec 2	–	Ch 3, Sec 10
Ch 3, Sec 1, [3]	Ch 8, Sec 3	Ch 3, Sec 2, [3]	Ch 9, Sec 3		
Ch 3, Sec 1, [4]	Ch 8, Sec 4	Ch 3, Sec 2, [4]	Ch 9, Sec 4		

CHAPTER 4 former edition July 2021 to current edition					
July 2021	Current edition	July 2021	Current edition	July 2021	Current edition
Ch 4, Sec 1, [1]	Ch 10, Sec 1	Ch 4, Sec 1, [4]	Ch 10, Sec 5	Ch 4, Sec 3, [1]	Ch 13, Sec 2
Ch 4, Sec 1, [2]	Ch 10, Sec 2	Ch 4, Sec 1, [5]	Ch 10, Sec 6	Ch 4, Sec 3, [2]	Ch 13, Sec 3
Ch 4, Sec 1, [3]	Ch 10, Sec 3	Ch 4, Sec 2	Ch 10, Sec 4		

<b>CHAPTER 5 former edition July 2021 to current edition</b>					
July 2021	Current edition	July 2021	Current edition	July 2021	Current edition
Ch 5, Sec 1	Ch 12, Sec 1	Ch 5, Sec 2, [11]	Ch 11, Sec 11	Ch 5, Sec 4, [5]	Ch 12, Sec 4, [3]
Ch 5, Sec 2, [1]	Ch 11, Sec 1	Ch 5, Sec 2, [12]	Ch 11, Sec 12	Ch 5, Sec 4, [6]	Ch 12, Sec 4, [4]
Ch 5, Sec 2, [2]	Ch 11, Sec 2	Ch 5, Sec 2, [13]	Ch 11, Sec 13	Ch 5, Sec 4, [7]	Ch 12, Sec 3, [3]
Ch 5, Sec 2, [3]	Ch 11, Sec 3	Ch 5, Sec 2, [14]	Ch 11, Sec 14	Ch 5, Sec 4, [8]	Ch 12, Sec 3, [4]
Ch 5, Sec 2, [4]	Ch 11, Sec 4	Ch 5, Sec 2, [15]	Ch 11, Sec 15	Ch 5, Sec 4, [9]	Ch 12, Sec 5
Ch 5, Sec 2, [5]	Ch 11, Sec 5	Ch 5, Sec 3	Ch 13, Sec 1	Ch 5, Sec 4, [10]	Ch 12, Sec 4, [5]
Ch 5, Sec 2, [6]	Ch 11, Sec 6	Ch 5, Sec 4, [1]	Ch 13, Sec 2	Ch 5, Sec 4, [11]	Ch 12, Sec 4, [6]
Ch 5, Sec 2, [7]	Ch 11, Sec 7	–	Ch 12, Sec 7, [1]	Ch 5, Sec 5	Ch 12, Sec 7
Ch 5, Sec 2, [8]	Ch 11, Sec 8	Ch 5, Sec 4, [2]	Ch 12, Sec 3, [2]	–	Ch 12, Sec 8
Ch 5, Sec 2, [9]	Ch 11, Sec 9	Ch 5, Sec 4, [3]	Ch 12, Sec 6		
Ch 5, Sec 2, [10]	Ch 11, Sec 10	Ch 5, Sec 4, [4]	Ch 12, Sec 4, [2]		

<b>CHAPTER 6 former edition July 2021 to current edition</b>	
July 2021	Current edition
Ch 6, Sec 1	Ch 14, Sec 1

## CHAPTER 2 TESTING PROCEDURES FOR MATERIALS

---

Section 1	General
Section 2	Tensile Test
Section 3	Bend Test
Section 4	Charpy V-Notch Impact Test
Section 5	Drop Weight Test
Section 6	Ductility Tests for Pipes and Tubes
Section 7	Other Tests

# Section 1                      General

## 1 Testing

### 1.1 Scope

**1.1.1** This Chapter gives the requirements for testing procedures, testing machines and test specimens for mechanical and technological tests of materials.

Alternative testing procedures and test specimens such as those complying with recognised standards may be accepted by agreement with the Society.

The tests to be performed and the results to be obtained are given in the Chapters of the Rules dealing with each product.

The general conditions given in Ch 1, Sec 1 also apply.

## 2 Testing machines

### 2.1 General requirements

**2.1.1** Testing machines are to be maintained in satisfactory condition and recalibrated at approximately annual intervals for adequate reliability, accuracy and sensitivity. This calibration is to be traced to a nationally recognised authority and is to be to the satisfaction of the Society. The records of the calibration are to be made available to the Surveyor, kept in the test laboratory and copies provided on request.

**2.1.2** Tension/compression testing machines are to be calibrated in accordance with ISO 7500-1:2018 or other recognised standard.

The accuracy of tensile test machines is to be within plus or minus one percent.

**2.1.3** Charpy impact testing machines are to have a striking energy of not less than 150J and are to be calibrated in accordance with ISO 148-2:2016 or other recognised standard.

## 3 Preparation of test specimens

### 3.1 General requirements

**3.1.1** The samples for test specimens are to be in the same condition as the product from which they have been taken and therefore in the same heat treatment condition, if any.

**3.1.2** If the test samples are cut from products by flame cutting or shearing, a reasonable margin is required to enable sufficient material to be removed from cut or sheared edges during final machining.

Test specimens are to be prepared in such a way that they are not subjected to any significant straining or heating which might alter the properties of the material.



## Section 2 Tensile Test

### 1 Test specimens and testing procedure

#### 1.1 Tensile test specimens

##### 1.1.1 General

Test specimens of proportional type should preferably be used as the values of minimum percentage elongation after fracture specified in the Rules refer to the gauge length  $L_0$  of these test specimens calculated by the following formula:

$$L_0 = 5,65 \sqrt{S_0}$$

This gauge length  $L_0$  should preferably be greater than 20 mm. The gauge length may be rounded off to the nearest 5 mm provided that the difference between this length and  $L_0$  is less than 10% of  $L_0$ .

##### 1.1.2 Proportional flat test specimen

For plates, strips and sections, proportional flat test specimens are usually used, with dimensions as shown in Fig 1.

For such products the tensile test specimens are to retain the original raw surfaces of the product.

When the capacity of the testing machine is insufficient to allow the use of test specimens of full thickness, this may be reduced by machining one of the raw surfaces.

Figure 1 : Proportional flat specimen

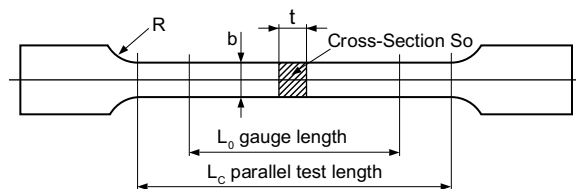

- $t$  : Thickness of the plate, strip or section, in mm  
 $b, R$  : Both equal to 25 mm  
 $L_0$  : Original gauge length, in mm, equal to:  

$$L_0 = 5,65 \sqrt{S_0}$$
 $S_0$  : Original specimen cross-section, in mm<sup>2</sup>  
 $L_C$  : Parallel test length, in mm, equal to:  

$$L_C = L_0 + 2 \sqrt{S_0}$$

##### 1.1.3 Non-proportional flat test specimen

Alternatively to the proportional flat test specimen, non-proportional flat test specimen having original gauge length of 200 mm and other dimensions as shown in Fig 2, may be used for plates, strips and sections.

Figure 2 : Non proportional flat specimen

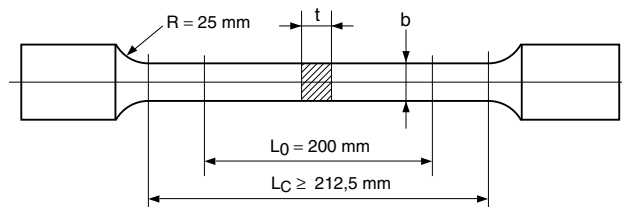

- $t$  : Thickness of the plate, strip or section, in mm  
 $b, R$  : Both equal to 25 mm  
 $L_0$  : Original gauge length, in mm  
 $L_C$  : Parallel test length, in mm.

##### 1.1.4 Round proportional test specimen

Alternatively to the flat test specimen for plates, strips or sections equal to or greater than 40 mm thick, proportional round test specimen, machined to the dimensions shown in Fig 3, may be used.

Round proportional test specimen is used for rolled products in aluminium alloy with thickness higher than 12,5mm.

For rolled bars, forgings and castings, grey cast iron excluded, round proportional test specimen are usually to be used.

Figure 3 : Round proportional specimen

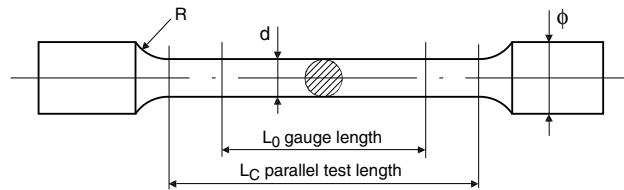

- $d$  : From 10 to 20 mm, preferably taken equal to 14 mm
- $L_0$  : Original gauge length, in mm, equal to  $5 \cdot d$
- $L_C$  : Parallel test length, in mm, such as  $L_C \geq L_0 + d / 2$
- $R$  : 10 mm (for nodular cast iron and materials with a specified elongation less than 10%,  $R \geq 1.5d$ )

**1.1.5 Round test specimen position**

For plates, strips and sections with thickness equal to or greater than 40 mm, the longitudinal axis of the round test specimen is to be located at a distance from one of the surfaces equal to one quarter of the thickness.

For rolled products in aluminium alloy with thickness up to and including 40mm, the longitudinal axis of the round test specimen is to be located at mid-thickness. For thicknesses over 40 mm, the longitudinal axis of the test specimen is to be located at a distance from one of the surfaces equal to one quarter of the thickness.

For bars and similar products, the longitudinal axis of the round test specimen is to be located at one third of the radius from the outside.

**1.1.6 Through thickness tensile test specimen**

Round test specimen including built-up type by welding are to be prepared in accordance with a recognised standard.

**1.1.7 Test specimen for grey cast iron**

For grey cast iron, the test specimen as shown in Fig 4 is to be used.

Figure 4 : Specimen for grey cast iron

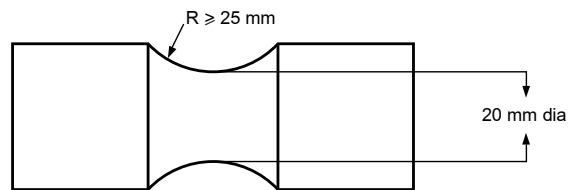

**1.1.8 Test specimens for pipes and tubes**

For pipes and tubes, the test specimen may be a full cross-section of suitable length to be secured in the testing machine with plugged ends, as shown in Fig 5.

The original gauge length  $L_0$  is to be equal to:

$$L_0 = 5,65 \sqrt{S_0}$$

and the distance between the grips  $L_C$  is to be not less than the gauge length plus  $D$ , where  $D$  is the external diameter of the tube or pipe.

The length of the plugs projecting over the grips, in the direction of the gauge marks, is not to exceed the external diameter  $D$ , and the shape of the plugs is not to impede the elongation of the gauge length.

Figure 5 : Full cross section specimen

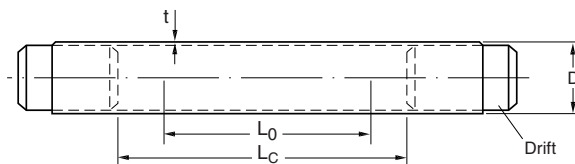

Alternatively, test specimens as shown in Fig 6 and taken from the tube or pipe wall may be used, where:

$$L_0 = 5,65 \sqrt{S_0}$$

$$L_C = L_0 + 2 b$$

$\alpha$  : Wall thickness, in mm.

The parallel test length is not to be flattened, but the enlarged ends may be flattened for gripping in the testing machine.

The round proportional test specimen shown in Fig 3 may be used provided that the wall thickness is sufficient to allow the machining of such test specimen with its axis located at the mid-wall thickness.

Figure 6 : Specimen taken from the tube or pipe wall

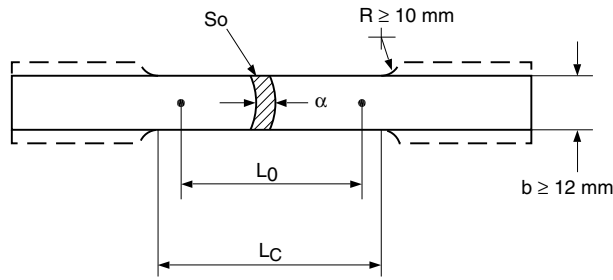

**1.1.9 Test specimen for wires**

For testing of wires, a full cross-section test specimen of suitable length is to be used.

The original gauge length is to be 200 mm and the parallel test length (distance between the grips) is to be 250 mm.

**1.1.10 Test specimen for deposited metal tensile test**

Round test specimen with the following dimensions is to be used:

- d = 10 mm
- L<sub>0</sub> = 50 mm
- L<sub>C</sub> ≥ 55 mm
- R ≥ 10 mm

For specially small or large dimensions, other test specimens may be used after agreement with the Society, provided they conform with the geometrical relationship given in Fig 3.

**1.1.11 Test specimen for butt weld transverse tensile test**

Flat test specimen as shown in Fig 7 and with the following dimensions is to be used:

- t : Thickness of the welded plate, in mm
- a = t
- b : Equal to 12 mm for t ≤ 2 mm  
25 mm for t > 2 mm
- L<sub>C</sub> : Width of the weld + 60 mm
- R > 25 mm.

The weld is to be machined (or ground) flush with the surface of the plate.

Figure 7 : Specimen for transverse tensile test on butt weld

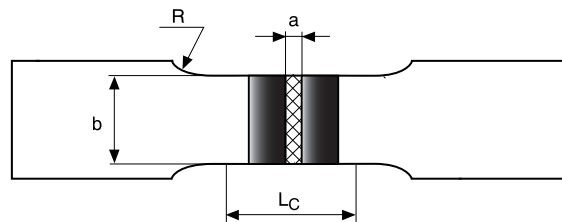

**1.1.12 Tolerances**

The tolerances on test specimen dimensions are to be in accordance with ISO 6892-1:2019, ISO 6892-2:2018 or other recognised standards as appropriate.

**1.2 Tensile test procedure**

**1.2.1 General**

The following characteristics, as required by the Rules for each product, are to be determined by the test:

- R<sub>eH</sub> : Upper yield stress (yield point), in N/mm<sup>2</sup>
- R<sub>p0.2</sub> - R<sub>p0.5</sub> - R<sub>p1.0</sub> : Proof stress (yield strength), in N/mm<sup>2</sup>
- R<sub>m</sub> : Tensile strength, in N/mm<sup>2</sup>
- A : Percentage elongation after fracture
- Z : Percentage reduction of area.

**1.2.2 Yield and proof stress determination**

For materials with well defined yield phenomenon, the upper yield stress  $R_{eH}$  is the value of stress at the moment when the first decrease in force is measured by the testing machine in the tensile tests at ambient temperature.

This applies, unless otherwise agreed, to products in carbon steels, carbon-manganese steels and alloy steels, except austenitic and duplex stainless steels.

When no well defined yield phenomenon exists, the type of proof stress required by the applicable specification is to be determined.

In general for steels, the conventional proof stress to be assumed is the 0,2 per cent proof stress or the 0,5 per cent proof stress, designated by the symbols  $R_{p0,2}$  and  $R_{p0,5}$ , respectively, where 0,2 and 0,5 are the percentage of permanent elongation.

For austenitic and duplex stainless steel products and relevant welding consumables, the 1,0 per cent proof stress, designated by the symbol  $R_{p1,0}$ , may be determined in addition to  $R_{p0,2}$ .

**1.2.3 Test rate**

Within the elastic range, the test is to be carried out with a stress rate within the following limits shown in Tab 1.

After reaching the yield or proof load, for ductile material the machine speed during the tensile test is not to exceed that corresponding to a strain rate of  $0,008\text{ s}^{-1}$ .

For brittle materials such as cast iron, the elastic stress rate is not to exceed  $10\text{ N/mm}^2$  per second.

**Table 1 : Stress rate within elastic range**

Modulus of elasticity E of the material (N/mm <sup>2</sup> )	Rate of stressing (N/mm <sup>2</sup> ·s <sup>-1</sup> )	
	Min.	Max.
< 150000	2	20
≥ 150000	6	60

**1.2.4 Percentage elongation after fracture**

The percentage elongation after fracture is usually determined on a proportional gauge length  $L_0$ . In that case, the percentage elongation after fracture is noted A or  $A_5$ .

$L_0$  is calculated from the following formula:

$$L_0 = 5,65\sqrt{S_0}$$

where:

$S_0$  : Original cross-sectional area of the test specimen.

When using round proportional test specimens,  $L_0$  is equal to 5 diameters.

When a gauge length other than proportional gauge length  $L_0$  is used, the equivalent per cent elongation  $A_x$  required is obtained from the following formula:

$$A_x = 2A_5\left(\frac{\sqrt{S}}{L}\right)^{0,4}$$

where:

$A_5$  : Minimum elongation, in per cent, required by the Rules for the proportional test specimens illustrated in Fig 1, Fig 3 and Fig 6

$S$  : Area, in mm<sup>2</sup>, of the original cross-section of the actual test specimen

$L$  : Length, in mm, of the corresponding gauge length actually used.

The above conversion formula may be used only for ferritic steel of low or medium strength and not cold worked.

The extension of the formula to other applications, such as cold worked steels, austenitic steels or non-ferrous materials is to be agreed with the Society.

In the case of disagreement, the value of elongation computed on the proportional test specimen is to be taken.

The gauge length used to determine the percentage elongation after fracture is to be indicated in the test reports.

For non-proportional test specimens with gauge length of 50 mm and 200 mm, the equivalent elongation values indicated in ISO 2566-1:1984, ISO 2566-2:1984 apply.

The elongation value is, in principle, valid only if the distance between the fracture and the nearest gauge mark is not less than one third of the original gauge length. However the result is valid irrespective of the location of the fracture if the percentage elongation after fracture is equal to or greater than the expected value.

The fracture surfaces of test specimens after the tensile test is to be examined. The fracture surfaces are to be sound and free from defects and irregularities.

### 1.2.5 Testing at high temperature

Tensile tests at high temperature are to be performed at the specified temperature in accordance with an appropriate national or international standard in agreement with the Society.

### 1.3 Tensile re-test procedure

**1.3.1** When the tensile test fails to meet the requirements, two further tests may be made from the same piece. If both of these additional tests are satisfactory the item and/or batch (as applicable) is acceptable. If one or both of these tests fail the item and/or batch is to be rejected.

The additional tests detailed above are to be taken, preferably from material taken adjacent to the original tests, but alternatively from another test position or sample representative of the item/batch.

## Section 3 Bend Test

### 1 Test specimens and testing procedure

#### 1.1 Flat bend test specimen

1.1.1 A flat bend test specimen as shown in Fig 1 is to be used.

The edges on the tension side are to be rounded to a radius of 1 to 2 mm.

The length of the test specimen is to be at least 11 times the thickness or 9 times the thickness plus the mandrel diameter, whichever is the greater.

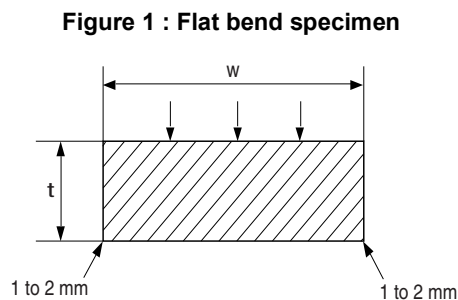

1.1.2 For castings, forgings, and semi-finished products, the other dimensions are to be as stated below:

- thickness:  $t = 20 \text{ mm}$
- width:  $w = 25 \text{ mm}$ .

1.1.3 For plates, sheets, strips and sections the other dimensions are to be as stated below:

- thickness:  $t = \text{thickness of the product}$
- width:  $w = 30 \text{ mm}$ .

If the as rolled thickness  $t$  is greater than 25 mm, it may be reduced to 25 mm by machining on the compression side of the bend specimen.

1.1.4 For transverse face and root bend test on butt welds, the other dimensions are to be as follows:

- thickness:  $t = \text{thickness of welded plates}$
- width:  $w = 30 \text{ mm}$ .

If the thickness  $t$  is greater than 25 mm, it may be reduced to 25 mm by machining on the compression side of the bend specimen. The surfaces of the weld are to be machined (ground) flush with the surface of the plate.

1.1.5 For transverse side bend test on butt welds, the other dimensions are to be as follows:

- thickness:  $t = 10 \text{ mm}$
- width:  $w = \text{thickness of welded plates}$ .

If the thickness of welded plates is equal or greater than 40mm, the side bend test specimen may be subdivided, each part being at least 20mm wide.

1.1.6 The test specimens for longitudinal face and root bend test on butt welds are to be in accordance with an appropriate recognised standard.

#### 1.2 Bend test procedure

1.2.1 The bend test is to be performed, as a rule, by applying a continuous mechanical compressive action on one of the surfaces of the test specimen.

The required mandrel diameter and the minimum bend angle are specified in the Articles dealing with the various products.

# Section 4 Charpy V-Notch Impact Test

## 1 Test specimens and testing procedure

### 1.1 Sampling

1.1.1 The Charpy V-notch impact test is, in general, performed on a set of 3 test specimens.

The longitudinal axis of the test specimens can be:

- a) parallel to the rolling direction of the plate, section or piece (longitudinal direction L), noted KVL in the Rules
- b) perpendicular to the rolling direction of the plate, section or piece (transverse direction T), noted KVT in the Rules
- c) parallel to other directions.

1.1.2 The axis of the V-notch is to be perpendicular to the faces of the plate, section or piece.

The position of the V-notch is not to be nearer than 25mm to a flame cut or sheared edge.

1.1.3 For rolled products with thickness less than or equal to 40 mm, the test specimens are to be taken retaining the original raw surface of the product or within 2 mm from it.

For rolled products with thickness higher than 40 mm, the test specimens are to be taken with their longitudinal axis located at 1/4 of the product thickness from one of the rolled surface, or as close as possible to such position.

### 1.2 Charpy V-notch test specimens

1.2.1 The test specimens are to be fully machined at the dimensions and tolerances shown in Fig 1 and Tab 1.

Figure 1 : Charpy V-notch test specimen

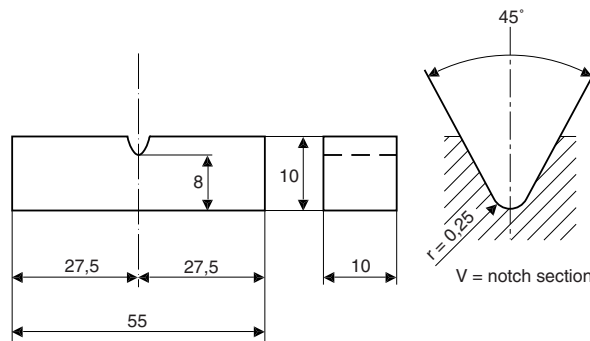

Table 1 : Charpy V-notch test specimen

Dimensions	Nominal	Tolerance
Length	55 mm	± 0,60 mm
Width		
• standard test specimen	10 mm	± 0,11 mm
• subsize test specimen	7,5 mm	± 0,11 mm
• subsize test specimen	5,0 mm	± 0,06 mm
Thickness	10 mm	± 0,06 mm
Depth below notch	8 mm	± 0,06 mm
Angle of notch	45°	± 2°
Root radius	0,25 mm	± 0,025 mm
Distance of notch from end of test specimen	27,5 mm	± 0,42 mm
Angle between plane of symmetry of notch and longitudinal axis of test specimen	90°	± 2°

**1.2.2** Test specimens with the largest possible size, reduced sectional area 10 x 7,5 or 10 x 5,0 are to be used if the thickness of the product does not allow to take test specimens of the standard size with sectional area 10 x 10.

The energy value required when using reduced size test specimen compared to standard size test specimen is given in Tab 2.

**Table 2 : Average energy value for reduced test specimens**

Sectional area of V-notch test specimens (mm <sup>2</sup> )	Minimum average energy <b>(1)</b>
10 x 10	KV
10 x 7,5	5/6 KV
10 x 5,0	2/3 KV

**(1)** KV is the required value on standard size test specimens, as per the Rules.

### 1.3 Charpy V-notch test procedure

**1.3.1** Ambient temperature means any temperature within the range 18 to 28°C.

Where the test temperature is lower than ambient, the temperature of the test specimen at the moment of breaking is to be the specified test temperature, within  $\pm 2^\circ\text{C}$ .

The test temperature is to be clearly stated in the testing documents.

**1.3.2** The unit used to report the energy values is to be clearly stated in the testing documents and should be preferably the Joule (J). The average of the three results from the test of the set is to comply with the value required for the product. Only one individual value may be less than the required average value, provided it is not less than 70% of that value.

### 1.4 Charpy V-notch re-test procedure

**1.4.1** When the average value of the three initial Charpy V-notch impact test specimens fails to meet the stated requirement, or the value for more than one test specimen is below the required average value, or when the value of any one test specimen is below 70% of the specified average value, three additional specimens from the same material may be tested and the results added to those previously obtained to form a new average. If this new average complies with the requirements and if not more than two individual results are lower than the required average and of these, not more than one result is below 70% of the specified average value the piece or batch (as applicable) may be accepted.



# Section 5 Drop Weight Test

## 1 General requirements

### 1.1 Test procedure and test specimens

**1.1.1** The drop weight test according to ASTM E208:2019 is used for determination of the NDT (nil ductility transition) temperature.

The NDT is the maximum temperature where the drop weight test specimen breaks when tested according to the provisions of the standard.

Drop weight test specimens have one of the following dimensions (thickness by width by length, in mm<sup>3</sup>):

- type P1: 25 x 90 x 360
- type P2: 19 x 50 x 130
- type P3: 16 x 50 x 130.

**1.1.2** The following apply, if not otherwise agreed:

- a) the test specimen sides are to be saw-cut or machined (minimum 25 mm distance to flame-cut surface)
- b) the machining of the sample to obtain the required thickness of the test specimen is to be carried out only on one surface; the opposite raw surface is to be maintained
- c) the specimens may be of any orientation, but the orientation is to be the same for all specimens.

## Section 6 Ductility Tests for Pipes and Tubes

### 1 Flattening test

#### 1.1 Test specimens and testing procedure

**1.1.1** The test specimen consists of a ring cut with smoothed ends perpendicular to the tube axis. The length of the specimen is to be from 10 mm to 100 mm. Reference is made to ISO 8492:2013.

**1.1.2** The test consists of compressing the test specimen between two rigid and parallel flat plates in a direction perpendicular to its longitudinal axis; the plates are to cover the whole test specimen after flattening.

It is to be continued until the distance  $Z$  between the two plates, measured under load, reaches the value specified.

In the case of welded pipes or tubes, the test is to be carried out with the weld seam positioned at  $90^\circ$  and at  $0^\circ$  to the flattening force.

After flattening, the test specimen is not to present any cracks or other flaws; however, small cracks at the ends may be disregarded.

### 2 Drift expanding test

#### 2.1 Test specimens and testing procedure

**2.1.1** The test specimen consists of a tube section having the ends perpendicular to the tube axis; the edges of the end to be tested may be rounded by filing.

**2.1.2** For metallic tubes, the length of the specimen is equal to  $2D$ , where  $D$  is the external diameter of the tube, if the angle of the drift is  $30^\circ$ , or equal to  $1,5D$  if the angle of the drift is  $45^\circ$  or  $60^\circ$ . The test piece may be shorter provided that after testing the remaining cylindrical portion is not less than  $0,5D$ . Reference is made to ISO 8493:1998.

**2.1.3** The rate of penetration of the mandrel shall not exceed 50 mm/min.

**2.1.4** The test consists of flaring the end of the test specimen at ambient temperature and symmetrically, by means of a truncated-cone shaped mandrel of hardened steel having the included angle specified in [2.1.2] (see Fig 1).

The mandrel is to be lubricated but is not to be rotated in the pipe during the test.

The mandrel penetration is to continue until the increase in external diameter of the end of the expanded zone reaches the value specified in the requirements relevant to the various products.

The expanded zone of the test specimen is not to present any cracks or other flaws.

Figure 1 : Drift expanding test

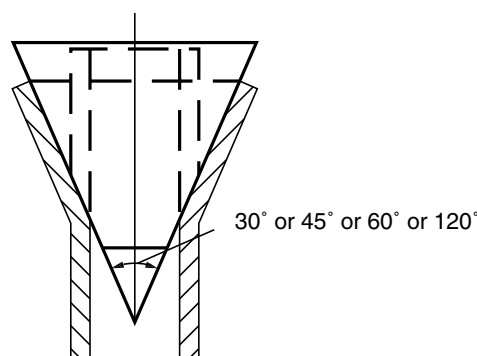

### 3 Flanging test

#### 3.1 Test specimens and testing procedure

**3.1.1** The test specimen consists of a tube section cut with the ends perpendicular to the tube axis; the edges of the end to be tested may be rounded by filing.

**3.1.2** The length of the test specimen is equal to approximately 1,5 times the external diameter of the tube. The test specimen may be shorter provided that after testing the remaining cylindrical portion is not less than half the external diameter.

**3.1.3** The test is carried out in two stages and consists of symmetrically forming a flange at one end of the test specimen by means of a special mandrel of hardened steel; the mandrel is to be lubricated but is not to be rotated in the tube during the test.

The rate of penetration of the forming tool shall not exceed 50 mm/min. Reference is made to ISO 8494:2013.

During the first stage of flanging, the end of the test specimen is expanded by means of a truncated-cone shaped mandrel having an included angle of 90°; the test is then continued during the second stage using a special forming mandrel to complete the flange.

The test is to be continued until the expanded zone forms a flange perpendicular to the longitudinal axis of the test specimen, with an increase in the external diameter of the end of the test specimen not less than the value specified (see Fig 2).

The cylindrical and flanged portion of the test specimen is not to present any cracks or other flaws.

After testing, the remaining cylindrical portion is to be not less than half the external diameter of the tube.

**Figure 2 : Flanging test**

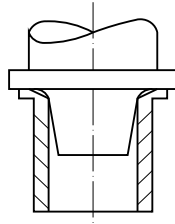

## 4 Ring expanding test

### 4.1 Test specimens and testing procedure

**4.1.1** The test specimen consists of a tube section cut with the ends perpendicular to the tube axis and the length between 10 and 16 mm.

**4.1.2** The rate of penetration of the mandrel shall not exceed 30 mm/s. Reference is made to ISO 8495:2013.

**4.1.3** The test specimen is to be expanded to the prescribed diameter or until fracture occurs (see Fig 3).

The expanded test specimen is not to reveal defects such as cracks, grooves or laminations and is to reach the prescribed expansion.

**Figure 3 : Ring expanding test**

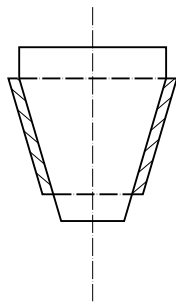

## 5 Ring tensile test

### 5.1 Test specimens and testing procedure

**5.1.1** The test specimen consists of a tube section with plain and smoothed ends cut perpendicular to the tube axis and with a length of about 15 mm.

**5.1.2** The test specimen is to be drawn to fracture in a tensile testing machine by means of two mandrels having diameter equal to at least three times the wall thickness of the pipe.

The rate shall not exceed 5 mm/s. Reference is made to ISO 8496:2013.

In the case of welded pipes the weld seam is to be at 90° to the direction of the tensile load.

The test specimen after fracture is not to reveal defects such as cracks, grooves or laminations and is to show visible deformation at the point of fracture.

## 6 Bend test on pipes and tubes

### 6.1 Test specimens and testing procedure

**6.1.1** Where feasible, the test specimen consists of full thickness strips not less than 40 mm in width (which may be machined down to 20 mm width for large thickness pipes) cut perpendicular to the pipe axis.

The edges of the test specimen may be rounded to 1,5 mm radius.

The result is considered satisfactory if, after being bent through the required angle in the direction of the original curvature, the test specimen is free from cracks and laminations; however, small cracks on the edges may be disregarded.

**6.1.2** For small diameter tubes, in general not exceeding 50 mm, the test specimen consists of a tube section of sufficient length. The test specimen is to be bent on a cylindrical mandrel with appropriate procedures as stated below, depending on the specification of the product:

- a) on a mandrel having a diameter 12 times the nominal diameter of the tube until an angle of 90° is reached
- b) on a mandrel having a diameter 8 times the nominal diameter of the tube, until an angle of 180° is reached.

The test specimen after bending is not to present any cracks or other flaws.

## Section 7 Other Tests

### 1 Strain age embrittlement test

#### 1.1 Test specimens and testing procedure

1.1.1 The test is performed according to the following requirements:

- a) the material is to be deformed, generally by compression (in special cases, deformation under tension may be permitted) until the required shortening (or elongation) (usually 3%, 5% or 10%) is attained
- b) the material is then to be heat treated in a furnace at 250°C for 1/2 h unless otherwise agreed
- c) Charpy impact test specimens are to be obtained from the strained and treated material and broken at the specified temperature.

When the deformation is reached by lateral compression, the procedure of artificial aging described above may be applied directly to the individual test specimens.

### 2 Macrographic and micrographic examinations

#### 2.1 Test specimens and testing procedure

2.1.1 The following examinations may be required to be performed as a random check for specific steel products:

- a) macrographic examination for detection of sulphur segregations (sulphur print or "Baumann test") according to ISO 4968:2022
- b) evaluation of the primary austenitic grain size "McQuaid Ehn test" according to ASTM E 112-13:2021. For fine grained steels, the "fine grain" condition is considered satisfied when the grain size is 5 or finer.

Test methods according to other recognised standards may be accepted by agreement with the Society.

2.1.2 The laboratory which carries out the examination is to issue a certificate of the results and photographic documentation of typical zones is to be enclosed.

### 3 Crack Tip Opening Displacement (CTOD) test

#### 3.1 Test specimens and testing procedure

3.1.1 Unless otherwise agreed, the test is to be performed on test specimens of full thickness according to appropriate national or international standards like BS 7448 Part 1:1991 and ASTM E1820:2021.

## **CHAPTER 3**

# **ROLLED STEEL PLATES, SECTIONS AND BARS**

---

Section 1	General Requirements
Section 2	Normal and Higher Strength Steels for Hull and other Structural Applications
Section 3	Normal and Higher Strength Corrosion Resistant Steels for Cargo Oil Tanks
Section 4	EH47 and Crack Arrest Steel Plates for Container Carriers
Section 5	Extra High Strength Steels for Welded Structures
Section 6	Steels for Boilers and Pressure Vessels
Section 7	Ferritic Steels for Low Temperature Service
Section 8	Steels for Machinery
Section 9	Stainless Steel Products
Section 10	High Manganese Austenitic Steel
Section 11	Clad Steel Plates
Section 12	Steels with Specified Through Thickness Properties

# Section 1 General Requirements

## 1 Scope

### 1.1 General

**1.1.1** The requirements of this Chapter apply to hot rolled plates, strips, sections and bars intended for hull, structural applications, boilers, pressure vessels and parts of machinery.

Sec 1 specifies the requirements common to all the above-mentioned steel products, while the appropriate specific requirements are indicated in Sec 2 to Sec 12.

## 2 Manufacturing process

### 2.1 Steel elaboration and casting

**2.1.1** Steel is to be manufactured by the electric furnace, basic oxygen or open hearth processes. The use of other processes may be specially approved by the Society.

**2.1.2** The steel is to be cast in ingot moulds or by a continuous casting process.

Provision is to be made for sufficient discard such as to ensure:

- at both ends of the ingots, the soundness of the material
- at the transitory zones of continuous casting material, a homogeneous chemical composition along the longitudinal axis.

## 3 Approval

### 3.1 Steelmaking and rolling process

**3.1.1** The manufacturing process is to be approved by the Society for individual steelmakers, grade of steel and products, as specified in the applicable Sections.

Provisions for the approval are given in the document NR480 "Approval of the manufacturing process of metallic materials".

**3.1.2** Rolling mills without their own steelmaking have to ensure that the slabs, blooms or ingots are supplied by works approved by the Society.

**3.1.3** It is the manufacturer's responsibility to assure that effective process and production controls in operation are adhered to within the manufacturing specifications. Where control imperfection inducing possible inferior quality of product occurs, the manufacturer is to identify the cause and establish a countermeasure to prevent its recurrence. Also, the complete investigation report is to be submitted to the surveyor. For further use, each affected piece is to be tested to the Surveyor's satisfaction. The frequency of testing for subsequent products offered may be increased at the discretion of the Society.

## 4 Quality of materials

### 4.1 General requirements

**4.1.1** All products are to have a workmanlike finish and to be free from surface or internal defects which may impair their proper workability and use.

**4.1.2** The responsibility for storage and maintenance of the delivered product(s) with acceptable level of surface conditions rests with the manufacturer or shipyard before the product(s) are used in fabrication.

## 5 Visual, dimensional and non-destructive examinations

### 5.1 General requirements

**5.1.1** Visual, dimensional and, as appropriate, non-destructive examinations are to be performed by the manufacturer on the materials supplied prior to delivery, as required.

Reference is made to the general provisions given in Ch 1, Sec 1, [3.6].

Non-destructive examinations may be required by the Surveyor when deemed necessary.

**5.1.2 Thickness tolerances of steel plates and wide flats**

The tolerances on thickness of a given product are defined as:

- minus tolerance is the lower limit of the acceptable range below the nominal thickness
- plus tolerance is the upper limit of the acceptable range above the nominal thickness.

The requirements for minus tolerances on nominal thickness are indicated in the Sections relevant to the various products.

The plus tolerance on nominal thickness are to be in accordance with a recognized national or international standard unless otherwise required by the Classification Society or purchaser.

The tolerances on nominal thickness are not applicable to areas repaired by grinding.

The responsibility for verification and maintenance of the production within the required tolerances rests with the manufacturer. The Surveyor may require to witness some measurements.

**5.1.3 Thickness measurements**

Automated method or manual method is applied to the thickness measurements.

At least two lines among Line 1, Line 2 or Line 3 as shown in Fig 1, are to be selected for the thickness measurements and at least three points on each selected line as shown in Fig 1 are to be selected for thickness measurement. If more than three points are taken on each line the number of points shall be equal on each line.

For automated methods, the measuring points at sides are to be located not less than 10 mm but not greater than 300 mm from the transverse or longitudinal edges of the product.

For manual methods, the measuring points at sides are to be located not less than 10 mm but not greater than 100 mm from the transverse or longitudinal edges of the product.

**Figure 1 : Locations of thickness measuring points**

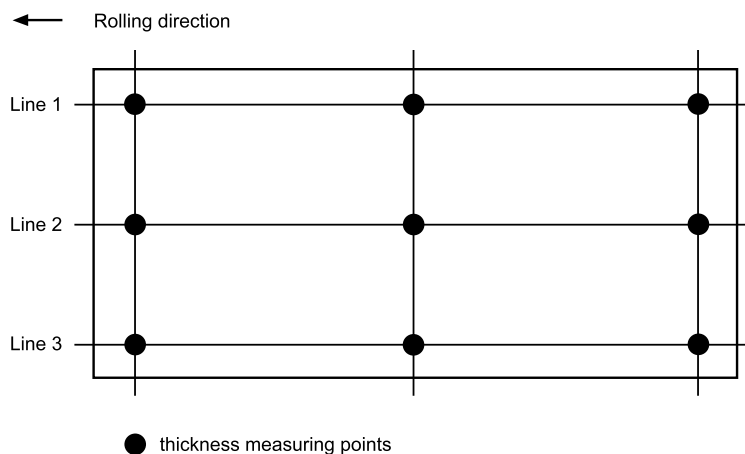

**6 Surface quality**

**6.1 General requirements**

**6.1.1** The finished material is to have a surface quality in accordance with a recognized standard such as EN 10163 parts 1, 2 and 3, or an equivalent standard accepted by the Society, unless otherwise specified in this **Chapter**.

The responsibility for meeting the surface finish requirements rests with the manufacturer of the material, who is to take the necessary manufacturing precautions and is to inspect the products prior to delivery. At that stage, however, rolling or heat treatment scale may conceal surface discontinuities and defects. If, during the subsequent descaling or working operations, the material is found to be defective, the Society may require materials to be repaired or rejected.

The surface quality inspection method shall be in accordance with recognized national or international standards agreed between purchaser and manufacturer, accepted by the Society.

**6.1.2 Rectification of surface defects by grinding**

Defects which need to be repaired may be removed by grinding.

The general provisions of Ch 1, Sec 1 and specific requirements for the various products as specified in the relevant Sections of this Chapter apply.

The repaired areas are to be ground smooth to the adjacent surface of the product.

The Surveyor may request that the complete removal of defects is verified by suitable non-destructive examination.



**6.1.3 Rectification of surface defects by welding**

Surface defects of products which cannot be removed as stated in [6.1.2] may be repaired by chipping or grinding followed by welding subject to the Surveyor's consent and under his supervision.

The general provisions of Ch 1, Sec 1 and specific requirements for the various products as specified in the relevant Sections of this Chapter apply.

**7 Condition of supply****7.1 General requirements**

**7.1.1** The conditions of supply are specified in the Sections relevant to the various products.

Where alternative supply conditions are agreed, the choice of the supply condition, unless otherwise required, is left to the manufacturer; the condition of supply is always to be mentioned in the testing documentation.

**7.1.2** When acceptable as an alternative to normalising, the procedures relevant to controlled or thermo-mechanical rolling process are to be specially approved for individual steelworks.

**7.1.3** The rolling practice applied is to comply with the appropriate condition of supply. The applicable procedures are defined as follows:

a) As Rolled, AR

This procedure involves steel being cooled as it is rolled with no further heat treatment. The rolling and finishing temperatures are typically in the austenite recrystallization region and above the normalising temperature. The strength and toughness properties of steel produced by this process are generally less than those of steel either heat treated after rolling or produced by advanced process.

b) Normalising, N

Normalising involves heating rolled steel above the critical temperature,  $A_{c3}$ , and in the lower end of the austenite recrystallization region for a specific period of time, followed by air cooling. The process improves the mechanical properties of as rolled steel by refining the grain size and homogenising the microstructure.

c) Controlled Rolling, CR (Normalising Rolling, NR)

This is a rolling procedure in which the final deformation is carried out in the normalising temperature range, allowed to cool in air, resulting in a material condition generally equivalent to that obtained by normalising.

d) Quenching and Tempering, QT

Quenching is a procedure which involves a heat treatment process in which steel is heated to an appropriate temperature above the  $A_{c3}$ , held for a specific period of time, and then cooled with an appropriate coolant for the purpose of hardening the microstructure. Tempering subsequent to quenching is a process in which the steel is reheated to an appropriate temperature not higher than the  $A_{c1}$ , maintained at that temperature for a specific period of time to restore toughness properties by improving the microstructure and reduce the residual stress caused by the quenching process.

Direct quenching after hot rolling, followed by tempering (DQ+T) is considered equivalent to conventional quenching and tempering.

e) Thermo-Mechanical rolling, TM (Thermo-Mechanical Controlled Processing, TMCP)

This is a procedure which involves the strict control of both the steel temperature and the rolling reduction. Generally a high proportion of the rolling reduction is carried out close to the  $A_{r3}$  temperature and may involve the rolling in the dual phase temperature region. Unlike controlled rolling (normalising rolling), the properties conferred by TM (TMCP) cannot be reproduced by subsequent normalising or other heat treatment.

The use of accelerated cooling on completion of TM-rolling may also be accepted, subject to the special approval of the Society. The same applies for the use of tempering after completion of the TM-rolling.

The generic designation Thermo-Mechanical rolling TM includes Direct Quenching followed by tempering (TM + DQ) after TM-rolling.

f) Accelerated Cooling, AcC

Accelerated cooling is a process which aims to improve the mechanical properties by controlled cooling with rates higher than air cooling immediately after the final TM-rolling operation. Direct quenching is excluded from accelerated cooling.

The material properties conferred by TM and AcC cannot be reproduced by subsequent normalising or other heat treatment.

**8 Sampling and testing****8.1 General requirements**

**8.1.1** All products are to be presented for testing in the final supply condition in batches or rolled units as specified in the Sections relevant to the various products.

**8.1.2 Sampling**

The samples required for the preparation of test specimens are, in general, to be cut from:

- a) the end of the plate or section corresponding to the top position of the ingot, in the case of casting in ingot moulds
- b) any end of the plate or section, where such products are rolled from blooms or billets manufactured by continuous casting, on the understanding that sufficient discard is taken from the transitory zones of the cast beginning and end
- c) both the ends of the coil for plates fabricated in coils.

Samples are to be taken from the following positions:

- plates and flats having width  $\geq 600$  mm: at approximately one quarter of the width from an edge (see Fig 2)
- flats having width  $< 600$  mm, bulb flats and sections: at approximately  $1/3$  of the width from an edge (see Fig 3, Fig 4 and Fig 5); alternatively, for channels, beams or bulb angles: on the web, at approximately  $1/4$  of the width from the centreline (see Fig 5)
- hollow sections: if rectangular, at approximately in the centreline of one side; if circular, at any position along the circumference
- bars: at approximately  $1/3$  of the radius or half-diagonal from the outer surface; the axis of the sample should be at least 12 mm from the outer surface, except for bars having diameter 25 mm or less, in which case the sample is to be concentric with the bar (see Fig 6).

**Figure 2 : Plates and flats**

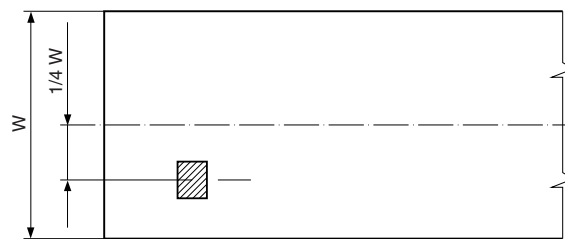

**Figure 3 : Bulb flats**

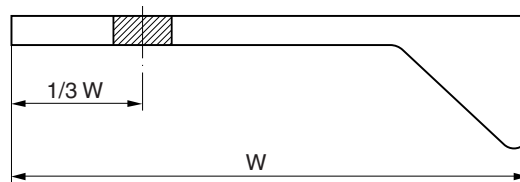

**Figure 4 : Angles**

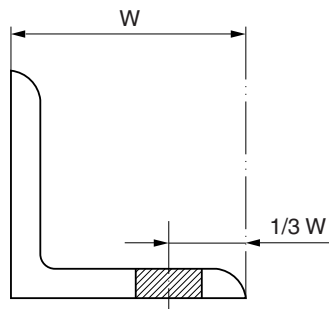

**Figure 5 : Sections**

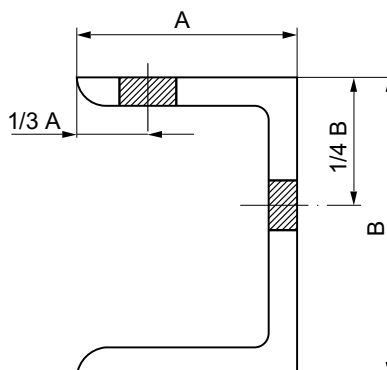
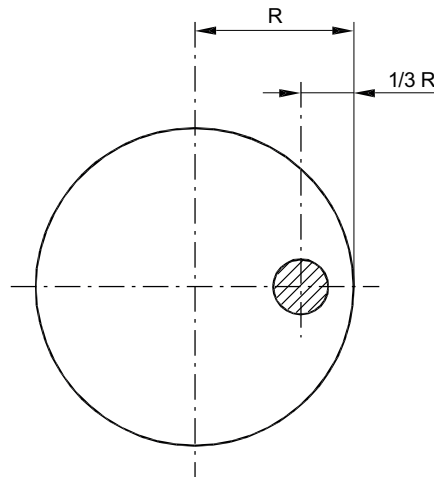

Figure 6 : Bars



### 8.1.3 Preparation of test specimens

The test specimens are to be cut from the samples with their principal axis parallel (longitudinal test) or perpendicular (transverse test) to the direction of rolling, as required in the Sections relevant to the various products.

For the preparation of test specimens and for the testing procedures, reference is to be made to the applicable requirements of Chapter 2.

### 8.1.4 Tensile test

The results of the test are to comply with the values specified in the Tables relevant to the various products.

If during the tensile test there is no marked yield stress  $R_{eHr}$ , the 0,2% proof stress  $R_{p0,2}$ , may be taken as an alternative.

### 8.1.5 Impact test

The average value is to comply with the minimum average value specified in the Tables relevant to the various products and only one individual value may be less than the average required, provided that it is not less than 70% of it.

The minimum average values are relevant to the standard specimen 10 x 10 mm<sup>2</sup>.

For subsize specimen dimensions and requirements, reference is to be made to Ch 2, Sec 4, [1.2.2].

### 8.1.6 Re-test procedures

Reference is made to Ch 1, Sec 1, [3.5].

For tensile re-test procedure, reference is made to Ch 2, Sec 2, [1.3].

For Charpy V-notch re-test procedure, reference is made to Ch 2, Sec 4, [1.4].

## 9 Identification and marking

### 9.1 General requirements

9.1.1 The manufacturer is to adopt a suitable system of identification which enables the product to be traced to its original cast.

9.1.2 All products which have been tested with satisfactory results are to be identified and marked, in addition to the Society's brand required in Ch 1, Sec 1, [4.1.3], with the following indications:

- manufacturer's name or trade mark
- identification mark for the grade of steel
- cast number or other marking, which will enable the history of the fabrication of the product to be traced.

Different marking systems are to be agreed with the Society.

## 10 Documentation and certification

### 10.1 General requirements

#### 10.1.1 Information required

The testing documentation indicated in Ch 1, Sec 1, [4.2.1] is required and is to contain all the appropriate information.

The ladle analysis is to include the content of refining and alloying elements as applicable.

### 10.1.2 Society's certificate

Before signing the Society's certificate, the Surveyor is to be provided by the manufacturer with a written declaration, stating that the material has been manufactured by a process accepted by the Society, complies with the applicable requirements and has been satisfactorily tested in accordance with the Rules.

The following wording may be acceptable, either printed or stamped on the delivery documents, with the name of the steel manufacturer and signed by one of his authorised representatives: "We hereby certify that the material has been made by an approved process and has been satisfactorily tested in accordance with the Society's Rules" (e.g. mill sheets).

### 10.1.3 Casting and rolling in different works

When the steel is not produced at the works at which it is rolled, a certificate is to be supplied to the Surveyor at the rolling mill stating the process by which it was manufactured, the name of the manufacturer who supplied it, the number of the cast from which it was made and the ladle analysis. The Surveyor is to have access to the works at which the steel was produced.

# Section 2 Normal and Higher Strength Steels for Hull and other Structural Applications

## 1 Requirements

### 1.1 Scope

**1.1.1** The requirements of this Section apply to weldable normal and higher strength steel hot rolled plates, wide flats, sections and bars intended for use in hull construction and other structural applications.

**1.1.2** Provision is made for:

- plates and wide flats of all grades not exceeding 100 mm in thickness
- sections and bars of all grades not exceeding 50 mm in thickness.

**1.1.3** For thickness greater than the above, the requirements may be modified, as appropriate, in the individual cases.

### 1.2 Steel grades

**1.2.1** The steels are classed, on the basis of a minimum yield strength level  $R_{eH}$  (N/mm<sup>2</sup>), into normal strength ( $R_{eH}=235$ ) and higher strength (32:  $R_{eH}=315$  - 36:  $R_{eH}=355$  - 40:  $R_{eH}=390$ ).

Normal strength steels are divided into four grades A, B, D and E. For normal strength steels, the letters A, B, D and E mean impact properties at +20°C, 0°C, -20°C and -40°C, respectively.

Higher strength steels are divided into four grades identified by the letters AH, DH, EH and FH followed by a number related to the yield strength level. For higher strength steels, the letters AH, DH, EH and FH mean impact properties at 0°C, -20°C, -40°C and -60°C, respectively.

**1.2.2** Steels differing in chemical composition, deoxidation practice, conditions of supply and mechanical properties may be accepted, subject to the special approval of the Society. Such steels are to be given a special designation.

### 1.3 Manufacture

#### 1.3.1 Approval

The manufacturers are to be approved by the Society and the relevant requirements of Sec 1, [2] and Sec 1, [3] apply.

Provisions for the approval are given in NR480 "Approval of the manufacturing process of metallic materials".

#### 1.3.2 Deoxidation process

The method of deoxidation is specified in Tab 1 and Tab 2.

#### 1.3.3 Rolling practice

Where CR (NR) and TM with or without AcC are applied, the programmed rolling schedules are to be submitted to the Society at the time of the approval and are to be made available when required by the attending Surveyor. On the manufacturer's responsibility, the programmed rolling schedules are to be adhered to during the rolling operation (as per Sec 1, [3.1.3]). To this effect, the actual rolling records are to be reviewed by the manufacturer and, occasionally, by the Surveyor.

When deviation from the programmed rolling schedules occurs, the manufacturer is to take further measures, to the Surveyor's satisfaction, in accordance with Sec 1, [3.1.3].

#### 1.3.4 Thickness and tolerances ( $t \geq 5\text{mm}$ )

The average thickness of plates and wide flats is defined as the arithmetic mean of the measurements made in accordance with Sec 1, [5.1.2]. The average thickness of plates and wide flats is not to be less than the nominal thickness.

For plates and wide flats with thicknesses of 5 mm and over, a minus tolerance on nominal thickness of 0,3 mm is permitted.

Alternatively, Class C of ISO 7452:2013 or equivalent according to national or international standards may be applied, in which case the requirements of this Section about average thickness and associated measurements need not be applied.

Additionally, if Class C of ISO 7452:2013 is applied, it is required that the steel mill demonstrates to the satisfaction of the Society that the number of measurements and measurement distribution are appropriate to establish that the mother plates produced are at or above the specified nominal thickness.

For sections and bars with thicknesses of 5mm and over, the minus tolerance on nominal thickness is to be in accordance with the requirements of a recognized international or national standard.

The plus tolerance on nominal thickness are to be in accordance with a recognized national or international standard unless otherwise required by the Classification Society.

The tolerances on nominal thickness are not applicable to areas repaired by grinding as indicated in [1.4.3] which are to be in accordance with a recognized standard.

### 1.3.5 Thickness and tolerances ( $t < 5\text{mm}$ )

The thickness tolerances for products with thicknesses below 5mm are to be in accordance with a national or international standard, e.g. Class B of ISO 7452:2013. However the minus tolerance shall not exceed 0.3mm.

## 1.4 Surface quality

### 1.4.1 General

The general requirements for surface quality of Sec 1, [6] apply.

### 1.4.2 Acceptance criteria

#### a) Imperfections

Imperfections of a harmless nature, for example pitting, rolled-in scale, indentations, roll marks, scratches and grooves, regarded as being inherent of the manufacturing process, are permissible irrespective of their number, provided the maximum permissible limits of Class A of EN 10163-2 or limits specified in a recognized equivalent standard accepted by the Society, are not exceeded and the remaining plate or wide flat thickness remains within the average allowable minus thickness tolerance specified in [1.3.4] or [1.3.5]. Total affected area with imperfection not exceeding the specified limits are not to exceed 15% of the total surface area in question.

#### b) Defects

Affected areas with imperfections with a depth exceeding the limits of Class A of EN 10163-2 or the maximum permissible limits specified in a recognized equivalent standard accepted by the Society, shall be repaired irrespective of their number.

Cracks, injurious surface flaws, shells (over lapping material with non-metallic inclusion), sand patches, laminations and sharp edged seams (elongated defects) visually evident on surface and/or edge of plate are considered defects, which would impair the end use of the product and which require rejection or repair, irrespective of their size and number.

### 1.4.3 Rectification of surface defects by grinding

Surface defects may be removed by grinding as indicated in Sec 1, [6.1.2] provided that:

- the nominal thickness will not be reduced by more than 7% or 3 mm, whichever is the less
- each single ground area does not exceed 0,25 m<sup>2</sup>
- the total ground area does not exceed 2% of the total surface of the plate
- adjacent repairs located at a distance less than their mean width are considered as forming a single ground area
- in the case of ground areas lying opposite each other on both surfaces of the plate, the resulting thickness is to satisfy in any place the values indicated in item a).

Defects or unacceptable imperfections are to be completely removed by grinding and the remaining plate or wide flat thickness shall remain within the average allowable minus thickness tolerance specified in [1.3.4] or [1.3.5].

The ground areas shall be a smooth transition to the surrounding surface of the product. Complete elimination of the defect is to be verified by magnetic particle or by liquid penetrant testing.

### 1.4.4 Rectification of surface defects by welding

Weld repair procedures and the method are to be reported and be approved by the Society. Repair of defects such as unacceptable imperfections, cracks, shells or seams shall be followed by magnetic particle or liquid penetrant testing.

Surface defects of products which cannot be removed as stated in [1.4.3] may be repaired by chipping or grinding followed by welding subject to the agreement of the Society and provided that:

- after removal of defects and weld preparation, the thickness of the piece is in no place reduced by more than 20% with respect to the nominal thickness. For occasional defects with depths exceeding 20% of nominal thickness, special consideration at the Surveyor's discretion will be necessary.
- repair is carried out by an approved procedure and by qualified welders. The electrodes shall be of low hydrogen type and shall be dried in accordance with the manufacturer's requirements and protected against rehumidification before and during welding.
- no single welded area exceeds 0,125 m<sup>2</sup> and the sum of all welded areas does not exceed 2% of the total surface area.
- The distance between two welded areas shall not be less than their average width.
- If weld repair depth exceeds 3mm, UT may be requested by the Society. If required, UT shall be carried out in accordance with an approved procedure.

**1.4.5** The surface quality and condition requirements herein are not applied to products in forms of bars and tubulars, which will be subject to manufacturer's conformance standards.

**Table 1 : Normal strength steels - Chemical composition and deoxidation practice**

Steel grade	A	B	D	E
Deoxidation practice for thickness t (mm)	t ≤ 50 mm: any method except rimmed <b>(1)</b> t > 50 mm: killed	t ≤ 50 mm: any method except rimmed t > 50 mm: killed	t ≤ 25 mm: killed t > 25 mm: killed and fine grain treated	killed and fine grain treated
Chemical composition (%) <b>(2) (3) (4)</b>				
C max <b>(5)</b>	0,21 <b>(6)</b>	0,21	0,21	0,18
Mn min <b>(5)</b>	2,5 x C	0,80 <b>(7)</b>	0,60	0,70
Si max	0,50	0,35	0,35	0,35
P max	0,035	0,035	0,035	0,035
S max	0,035	0,035	0,035	0,035
Al (acid soluble) min			0,015 <b>(8) (9)</b>	0,015 <b>(9)</b>
<p><b>(1)</b> For sections up to a thickness of 12,5 mm, rimmed steel may be accepted subject to the special approval of the Society</p> <p><b>(2)</b> When any grade of steel is supplied in the thermo-mechanically rolled condition, variations in the specified chemical composition may be allowed or required by the Society and are to be stated at the approval</p> <p><b>(3)</b> The Society may limit the amount of residual elements which may have an adverse effect on the working and use of the steel, e.g. copper and tin</p> <p><b>(4)</b> Where additions of any other element have been made as part of the steelmaking practice, the content is to be indicated in the ladle analysis certificate</p> <p><b>(5)</b> C +1/6 Mn is not to exceed 0,40%</p> <p><b>(6)</b> Max. 0,23% for sections</p> <p><b>(7)</b> When Grade B steel is impact tested, the minimum manganese content may be reduced to 0,60%</p> <p><b>(8)</b> Al is required for thickness greater than 25 mm</p> <p><b>(9)</b> The total aluminum content may be determined instead of acid soluble content. In such cases the total aluminum content is to be not less than 0,020%. Other suitable grain refining elements may be used subject to the special approval of the Society</p>				

**Table 2 : Higher strength steels - Chemical composition and deoxidation practice**

Steel grade	AH32, DH32, EH32 AH36, DH36, EH36 AH40, DH40, EH40	FH32, FH36, FH40
Deoxidation practice	killed and fine grain treated	killed and fine grain treated
Chemical composition (%) <b>(1) (5)</b>		
C max.	0,18	0,16
Mn	0,90 - 1,60 <b>(2)</b>	0,90 - 1,60
Si max.	0,50	0,50
P max.	0,035	0,025
S max.	0,035	0,025
Al (acid soluble) min <b>(3) (4)</b>	0,015	0,015
Nb <b>(4)</b>	0,02 - 0,05	0,02 - 0,05
V <b>(4)</b>	0,05 - 0,10	0,05 - 0,10
Ti max. <b>(4)</b>	0,02	0,02
Cu max.	0,35	0,35
Cr max.	0,20	0,20
Ni max.	0,40	0,80
Mo max.	0,08	0,08
N max.		0,009 (0,012 if Al is present)
<p><b>(1)</b> Alloying elements other than those listed above or exceeding the specified limits may be accepted by the Society when proposed by the steelmaker at the time of approval and their content is to be indicated in the ladle analysis.</p> <p><b>(2)</b> Up to a thickness of 12,5 mm, the minimum manganese content may be reduced to 0,70.</p> <p><b>(3)</b> The total aluminium content may be determined instead of the acid soluble content. In such cases the total aluminium content is to be not less than 0,020%.</p> <p><b>(4)</b> The steel is to contain aluminium, niobium, vanadium or other suitable grain refining elements, either singly or in any combination. When used singly, the steel is to contain the specified minimum content of the grain refining element. When used in combination, the specified minimum content of at least one grain refining element is applicable; the sum of Nb + V + Ti is not to exceed 0,12%.</p> <p><b>(5)</b> When any grade of higher strength steel is supplied in the thermo-mechanically rolled condition, variations in the specified chemical composition may be allowed or required by the Society and are to be stated at the approval.</p>		

**1.5 Internal soundness**

**1.5.1** If plates and wide flats are ordered with ultrasonic testing, this is to be made in accordance with an accepted standard at the discretion of the Classification Society.

**1.5.2** Ultrasonic testing of plates intended for offshore structural applications of first and special category as defined in the Society's Offshore Rules is required and is to be performed in accordance with a recognized standard (e.g. EN 10160 or ASTM A 578) and an examination level accepted by the Society.

**1.5.3** Verification of internal soundness is the responsibility of the manufacturer. The acceptance of internal soundness by the Society's surveyor shall not absolve the manufacturer from this responsibility.

**1.6 Condition of supply**

**1.6.1** The products are to be supplied in the condition indicated in Tab 5 and Tab 6 for normal strength steels and Tab 9 and Tab 10 for higher strength steels.

The definition of the supply conditions is given in Sec 1, [7.1.3].

**1.7 Chemical composition**

**1.7.1 General**

The chemical composition is determined by the manufacturer on ladle samples (see Ch 1, Sec 1, [2.2.1]).

**1.7.2 Normal strength steels**

The chemical composition is to comply with the requirements specified in Tab 1.

**1.7.3 Higher strength steels**

The chemical composition is to comply with the requirements specified in Tab 2.

At the time of the approval of higher strength steels, an upper limit for carbon equivalent  $C_{EQ}$  on the ladle analysis may be specified.

Unless otherwise agreed, the value of  $C_{EQ}$  is calculated by the following formula:

$$C_{EQ} = C + \frac{Mn}{6} + \frac{Cr + Mo + V}{5} + \frac{Ni + Cu}{15} \quad \%$$

For steel produced by thermo-mechanical rolling,  $C_{EQ}$  is to comply with the requirements of Tab 3.

As an alternative to  $C_{EQ}$ , at the discretion of the Society, the cold cracking susceptibility  $P_{cm}$  may be used for evaluating the weldability.

$P_{cm}$  is given by the following formula and an upper limit may be agreed at the time of the approval of the steel:

$$P_{cm} = C + \frac{Si}{30} + \frac{Mn}{20} + \frac{Cu}{20} + \frac{Ni}{60} + \frac{Cr}{20} + \frac{Mo}{15} + \frac{V}{10} + 5B \quad \%$$

When a limit of  $C_{EQ}$  and  $P_{cm}$  is required, the relevant values are to be stated by the manufacturer and included in the testing documentation for each cast.

**Table 3 : Carbon equivalent for higher strength steels up to 100 mm in thickness produced by TM process**

Steel grade	Carbon equivalent $C_{EQ}$ max. (%) (1)	
	$t \leq 50$	$50 < t \leq 100$
AH32, DH32, EH32, FH32	0,36	0,38
AH36, DH36, EH36, FH36	0,38	0,40
AH40, DH40, EH40, FH40	0,40	0,42
t = thickness (mm)		
(1) More stringent carbon equivalent limits may be agreed between the manufacturer and the shipbuilder in individual cases.		

**1.8 Mechanical properties**

**1.8.1 Normal strength steels**

The mechanical properties are indicated in Tab 4.

The number of impact tests to be performed is indicated in Tab 5 for plates and wide flats and Tab 6 for sections and bars.

**1.8.2 Higher strength steels**

The mechanical properties are indicated in Tab 7.

The condition of supply and the number of impact tests to be performed are indicated in Tab 9 for plates and wide flats and Tab 10 for sections and bars.



**Table 4 : Normal strength steels - Mechanical properties**

Steel grade	Yield stress R <sub>eH</sub> (N/mm <sup>2</sup> ) min.	Tensile strength R <sub>m</sub> (N/mm <sup>2</sup> )	El. A <sub>5</sub> (%)min (1)	Average impact energy (J) min KVL longitudinal - KVT transverse - t = thickness (mm)						
				Test temp (°C)	t ≤ 50		50 < t ≤ 70		70 < t ≤ 100	
					KVL	KVT	KVL	KVT	KVL	KVT
A	235	400/520 (2)	22	+20			34	24	41	27
B	235	400/520	22	0	27	20	34	24	41	27
D	235	400/520	22	-20	27	20	34	24	41	27
E	235	400/520	22	-40	27	20	34	24	41	27

(1) El.: elongation. For full thickness flat tensile test specimens with a width of 25 mm and a gauge length of 200mm, the elongation is to comply with the minimum values given for strength level 32 in Tab 8.

(2) For sections in grade A of all thicknesses, the upper limit for the specified tensile stress range may be exceeded up to a maximum of 540 N/mm<sup>2</sup>.

**Table 5 : Normal strength plates and wide flats - Condition of supply and number of impact tests**

Steel grade	Condition of supply (1)			
	Batch for impact tests in tonnes () for thickness t (mm) (2)			
	t ≤ 25	25 < t < 35	35 ≤ t ≤ 50	50 < t ≤ 100
A	A(-)			(N,TM)(-), NR(50), AR*(50) (3)
B	A (-) (4)	A(50)	(N,TM)(50), NR(25), AR*(25)	
D	A(50)		(N,NR,TM)(50)	(N,TM)(50), NR(25)
E	N or TM (each piece)			

(1) Abbreviations:  
 A : Any  
 N : Normalised Condition (heat treatment)  
 NR : Normalising Rolled Condition as an alternative to Normalising  
 TM : Thermo-Mechanical Rolling  
 AR\* : As Rolled Condition subject to the special approval of the Society.

(2) One set of impact tests is to be taken from each batch of the weight in tonnes specified in brackets (), from each fraction thereof or from each piece as indicated. When impact tests are not required the indication is (-).

(3) Charpy V-notch tests are generally not required for fine grained grade A products over 50 mm thick N or TM; when required, the rate is at the Society's discretion.

(4) Charpy V-notch tests are generally not required for Grade B steel with thickness of 25 mm or less; when required, the rate is at the Society's discretion.

**Table 6 : Normal strength sections and bars - Condition of supply and number of impact tests**

Steel grade	Condition of supply (1)		
	Batch for impact tests in tonnes () for thickness t (mm) (2)		
	t ≤ 25	25 < t ≤ 35	35 < t ≤ 50
A	A (-)		
B	A (-) (3)	A (50)	
D	A (50)		N(50), NR(50), TM(50), AR*(25)
E	N(25), TM(25), AR*(15), NR*(15)		

(1) Abbreviations:  
 A : Any  
 N : Normalised Condition (heat treatment)  
 NR : Normalising Rolled Condition as an alternative to Normalising  
 TM : Thermo-Mechanical Rolling  
 AR\* : As Rolled Condition subject to the special approval of the Society  
 NR\* : Normalising Rolled Condition subject to the special approval of the Society.

(2) One set of impact tests is to be taken from each batch of the weight in tonnes specified in brackets () or fraction thereof. When impact tests are not required, the indication is (-).

(3) Charpy V-notch impact tests are generally not required for grade B steel with thickness of 25 mm or less.

**Table 7 : Higher strength steels - Mechanical properties**

Steel grade	Yield stress $R_{eH}$ (N/mm <sup>2</sup> ) min.	Tensile strength $R_m$ (N/mm <sup>2</sup> )	Elong. $A_5$ (%) min. <b>(1)</b>	Average impact energy (J) min. for thickness t (mm)						
				Test temp. (°C)	t ≤ 50		50 < t ≤ 70		70 < t ≤ 100	
					KVL	KVT	KVL	KVT	KVL	KVT
AH32 DH32 EH32 FH32	315	440/570	22	0 - 20 - 40 - 60	31 31 31 31	22 22 22 22	38 38 38 38	26 26 26 26	46 46 46 46	31 31 31 31
AH36 DH36 EH36 FH36	355	490/630	21	0 - 20 - 40 - 60	34 34 34 34	24 24 24 24	41 41 41 41	27 27 27 27	50 50 50 50	34 34 34 34
AH40 DH40 EH40 FH40	390	510/660	20	0 - 20 - 40 - 60	39 39 39 39	26 26 26 26	46 46 46 46	31 31 31 31	55 55 55 55	37 37 37 37

**(1)** For full thickness flat tensile test specimens with a width of 25 mm and a gauge length of 200 mm, the elongation is to comply with the minimum values given in Tab 8.

**Table 8 : Elongation (%) on a gauge length of 200 mm for thickness t (mm)**

Strength grade	t ≤ 5	5 < t ≤ 10	10 < t ≤ 15	15 < t ≤ 20	20 < t ≤ 25	25 < t ≤ 30	30 < t ≤ 40	40 < t ≤ 50
32	14	16	17	18	19	20	21	22
36	13	15	16	17	18	19	20	21
40	12	14	15	16	17	18	19	20

**Table 9 : Higher strength plates and wide flats - Condition of supply and number of impact tests**

Steel grade	Grain refining elements	Condition of supply <b>(1)</b>					
		Batch for impact tests in tonnes ( ) for thickness t (mm) up to: <b>(2)</b>					
		12,5	20	25	35	50	100
AH32 <b>(3)</b>	Nb and/or V	A(50)	N(50), NR(50), TM(50)			N(50), NR(25), TM(25)	
AH36 <b>(3)</b>	Al only or with Ti	A(50)	AR*(25)		Not applicable		
			N(50), NR(50), TM(50)			N(50), NR(25), TM(50)	
AH40	Any	A(50)	N(50), NR(50), TM(50)			N(50), TM(50), QT (each piece as heat treated)	
DH32 DH36	Nb and/or V	A(50)	N(50), NR(50), TM(50)			N(50), NR(25), TM(50)	
			Al only or with Ti	A(50)	AR*(25)		Not applicable
N(50), NR(50), TM(50)					N(50), NR(25), TM(50)		
DH40	Any	N(50), NR(50), TM(50)				N(50), TM(50), QT (each piece as heat treated)	
EH32 EH36	Any	N (each piece), TM (each piece)					
EH40	Any	N (each piece), TM (each piece), QT (each piece as heat treated)					
FH32 FH36	Any	N (each piece), TM (each piece), QT (each piece as heat treated)					
FH40	Any	N (each piece), TM (each piece), QT (each piece as heat treated)					

**(1)** Abbreviations:  
A : Any  
N : Normalised Condition (heat treatment)  
NR : Normalising Rolled Condition as an alternative to Normalising  
TM : Thermo-Mechanical Rolling  
QT : Quenched and Tempered Condition  
AR\* : As Rolled Condition subject to the special approval of the Society.

**(2)** One set of impact tests is to be taken from each batch of the weight in tonnes specified in brackets ( ), from each fraction thereof or from each piece as indicated. When impact tests are not required the indication is (-).

**(3)** For Grades AH32 and AH36 steels, a relaxation in the number of impact tests may be permitted by special agreement with the Society, provided that satisfactory results are obtained from occasional checks.

**Table 10 : Higher strength sections and bars - Condition of supply and number of impact tests**

Steel grade	Grain refining elements	Condition of supply (1)		
		Batch for impact test in tonnes ( ) for thickness t (mm) up to: (2)		
		12,5	20	50
AH32 (3) AH36 (3)	Nb and/or V	A(50)	N(50), NR(50), TM(50), AR*(25)	
	Al only or with Ti	A(50)		N(50), NR(50), TM(50), AR*(25)
AH40	Any	A(50)	N(50), NR(50), TM(50)	
DH32 DH36	Nb and/or V	A(50)	N(50), NR(50), TM(50), AR*(25)	
	Al only or with Ti	A(50)		N(50), NR(50), TM(50), AR*(25)
DH40	Any	N(50), NR(50), TM(50)		
EH32 EH36	Any	N(25), TM(25), AR*(15), NR*(15)		
EH40	Any	N(25), TM(25), QT(25)		
FH32 FH36	Any	N(25), TM(25), QT(25), NR*(15)		
FH40	Any	N(25), TM(25), QT(25)		
<p>(1) Abbreviations:                      A : Any                      N : Normalised Condition (heat treatment)                      NR : Normalising Rolled Condition as an alternative to Normalising                      TM : Thermo-Mechanical Rolling                      QT : Quenched and Tempered Condition                      AR* : As Rolled Condition subject to the special approval of the Society                      NR* : Normalising Rolled Condition subject to the special approval of the Society.</p> <p>(2) One set of impact tests is to be taken from each batch of the weight in tonnes specified in brackets ( ) or fraction thereof.</p> <p>(3) For Grades AH32 and AH36 steels, a relaxation in the number of impact tests for acceptance purposes may be permitted by special agreement with the Society provided that satisfactory results are obtained from occasional checks.</p>				

## 1.9 Mechanical tests

### 1.9.1 General

Samples for mechanical tests are to be cut from the products in the final supply condition. The tests are to be carried out on pieces selected from batches or on individual pieces as required in [1.9.5] and [1.9.6].

### 1.9.2 Batch testing

All materials in the batch are to be from the same heat, of the same product type, in the same condition of supply and within the following ranges of thickness and mass:

- a) difference between minimum and maximum thicknesses not exceeding 10 mm
- b) mass not exceeding 50 t.

For products of steel type A intended for secondary applications, the batch composition may not be required to be restricted to material from the same heat, but in such case the mass of the batch is not to exceed 25 t.

### 1.9.3 Individual testing

For tests on individual pieces the term piece means rolled unit as defined in Ch 1, Sec 1, [3.3.3].

### 1.9.4 Sampling

For plates and flats having width  $\geq 600$  mm, the specimens for tensile test are to be taken in the transverse direction and the specimens for the Charpy V-notch impact test in the longitudinal direction (KVL).

In the other cases, the specimens are to be taken in the longitudinal direction, unless otherwise required by or agreed with the Society.

The impact test requirements specified on transverse specimens (KVT) are to be guaranteed by the manufacturer and random checks may be required by the Society.

Generally, impact tests are not required when the nominal product thickness is less than 6 mm.

For plates fabricated in coils, the tensile and impact tests required are to be duplicated on specimens taken from samples cut at both ends of the coil.

Sampling positions are indicated in Sec 1, [8.1.2].

Additional through thickness tests may be required for special applications and are to be carried out according to the requirements of Sec 12.

### 1.9.5 Number of tensile tests

One tensile test is to be carried out from one piece for each batch presented or fraction thereof.

In general the specimen is to be taken from a piece selected in the batch among those with the highest thickness.

### 1.9.6 Number of impact tests

The number of sets of impact tests required is indicated in Tab 5 and Tab 6 for normal strength products and Tab 9 and Tab 10 for higher strength products.

When testing is by batches, the specimens are to be taken from a piece selected among those of the batch having the highest thickness.

The number of sets of specimens for the impact test, each of three specimens, summarised in the above-mentioned Tables, is to be in accordance with the following requirements:

- a) one set is required for each batch of 50 tonnes, or fraction thereof for the following grades of steel, unless otherwise specified in b):
  - A, for products having thickness > 50 mm
  - B, for products having thickness > 25 mm
  - D, AH32, DH32, AH36, DH36, AH40, DH40
- b) except for grade A, for products supplied subject to special approval in the as rolled condition (AR\*), and for products with thickness higher than 50 mm supplied in the controlled rolled condition (NR), the mass of the batches for the purpose of impact tests is to be 25 t, or a fraction thereof
- c) one set of three impact test specimens is required for:
  - each piece for grades E and F in all strengths
  - each batch of 25 t or fraction thereof of sections of grades E and F in all strengths
- d) when, subject to special approval, sections of steel grades E and F in all strengths other than 40 are supplied in the as rolled (AR\*) or controlled rolled (NR\*) condition, the mass of the batches for the purpose of impact tests is to be 15 t, or a fraction thereof.

Random checks of the impact values may be required at the discretion of the Surveyor.

# Section 3 Normal and Higher Strength Corrosion Resistant Steels for Cargo Oil Tanks

## 1 Requirements

### 1.1 Scope

**1.1.1** The requirements of this Section apply to normal and higher strength corrosion resistant steels when such steel is used as the alternative means of corrosion protection for cargo oil tanks as specified in the performance standard MSC.289(87) of Regulation 3-11, Part A-1, Chapter II-1 of the SOLAS Convention (Corrosion protection of cargo oil tanks of crude oil tankers).

**1.1.2** Normal and higher strength corrosion resistant steels are steels whose corrosion resistance performance in the bottom or top of the internal cargo oil tank is tested and approved to satisfy the requirements in the performance standard MSC.289 (87). It is not intended that such steels be used for corrosion resistant applications in other areas of a vessel that are outside of those specified in the performance standard MSC.289 (87) of Regulation 3-11, Part A-1, Chapter II-1 of the SOLAS Convention.

**1.1.3** Provision is made for:

- plates and wide flats of all grades not exceeding 50 mm in thickness
- sections and bars of all grades not exceeding 50 mm in thickness.

### 1.2 Steel grades

**1.2.1** The requirements of Sec 3 are intended as a supplement to the requirements of Sec 2, which specify the steel grades for hull structures.

**1.2.2** The corrosion resistant grade is designated according to its area of application with one of the following suffixes:

- lower surface of strength deck and surrounding structures: RCU
- upper surface of inner bottom plating and surrounding structures: RCB
- for both strength deck and inner bottom plating: RCW.

The suffix is given to any steel grade which has been tested according to the present Section and to the corrosion testing procedure defined in the Appendix of the Annex to Performance Standard for Alternative Means of Corrosion Protection for Cargo Oil Tanks of Crude Oil Tankers MSC.289(87).

### 1.3 Manufacture

#### 1.3.1 Approval

Approval may be given for a steel grade for application in one of the following areas of cargo oil tank:

- lower surface of strength deck and surrounding structures
- upper surface of inner bottom plating and surrounding structures
- for both strength deck and inner bottom plating.

The requirements of Sec 1, [2] and Sec 1, [3] apply.

Provisions for the approval are given in NR480 "Approval of the manufacturing process of metallic materials".

### 1.4 Chemical composition

**1.4.1** The chemical composition of samples taken from each ladle of each cast is to be determined by the manufacturer and is to be in accordance with the appropriate requirements of Sec 2, [1.7].

The weight percentage of each element added or intentionally controlled for improving corrosion resistance is to be determined and is to be in compliance with the approved steel grade specification.

Carbon equivalent requirements are to be in accordance with Sec 2, [1.7], as applicable.

### 1.5 Marking

**1.5.1** In addition to the requirements of Sec 1, [9], the appropriate suffix RCU, RCB or RCW is to be marked.

# Section 4 EH47 and Crack Arrest Steel Plates for Container Carriers

## 1 Requirements

### 1.1 Scope

**1.1.1** The requirements of this Section apply to hot rolled plates in EH47 and crack arrest steels intended for longitudinal structural members in the upper deck region of container carriers, when required by the applicable rules.

**1.1.2** Provisions are given for EH47 and crack arrest steels in thickness greater than 50mm and not greater than 100mm. Outside the scope of that thickness range, special consideration is to be given by the Society.

### 1.2 Steel grades

**1.2.1** The crack arrest steels are classed into three groups, on the basis of a minimum yield strength level  $R_{eH}$ , in N/mm<sup>2</sup> (36:  $R_{eH}$  = 355; 40:  $R_{eH}$  = 390; 47:  $R_{eH}$  = 460).

Each group is further subdivided into two grades EH and FH based of the impact test temperature. The letters EH and FH mean impact properties at -40°C and -60°C, respectively.

For crack arrest steels, the suffix CAS1 or CAS2 is added to the grade.

### 1.3 Manufacture

#### 1.3.1 Approval

The manufacturers are to be approved by the Society and the relevant requirements of Sec 1, [2] and Sec 1, [3] apply.

Provisions for the approval are given in NR480 "Approval of the manufacturing process of metallic materials".

#### 1.3.2 Deoxidation process

The steel is to be killed and fine grain treated.

#### 1.3.3 Rolling practice

Where CR (NR) and TM (with or without AcC) are applied, the programmed rolling schedules are to be submitted to the Society at the time of the approval and are to be made available when required by the attending Surveyor. On the manufacturer's responsibility, the programmed rolling schedules are to be adhered to during the rolling operation, (as per Sec 1, [3.1.3]). To this effect, the actual rolling records are to be reviewed by the manufacturer and, occasionally, by the Surveyor.

When deviation from the programmed rolling schedules occurs, the manufacturer is to take further measures, to the Surveyor's satisfaction, in accordance with Sec 1, [3.1.3].

#### 1.3.4 Thickness tolerances and surface condition

Unless otherwise agreed or specially required, the requirements for tolerances on nominal thickness, surface condition and rectification of surface defects are indicated in Sec 2, [1.3.4] or Sec 2, [1.3.5] and Sec 2, [1.4].

### 1.4 Condition of supply

**1.4.1** The plates are to be supplied in the condition indicated in Tab 1.

The definition of the supply conditions is given in Sec 1, [7.1.3].

### 1.5 Chemical composition

**1.5.1** The chemical composition on ladle analysis is to comply with the requirements specified in Tab 2.

**1.5.2** For steel produced by thermo-mechanical rolling,  $C_{EQ}$  and Pcm value are to comply with the requirement of Tab 3.

The value of  $C_{EQ}$  is calculated by the following formula:

$$C_{EQ} = C + \frac{Mn}{6} + \frac{Cr + Mo + V}{5} + \frac{Ni + Cu}{15} \quad \%$$

The Pcm value is to be calculated from the ladle analysis in accordance with the following formula:

$$P_{cm} = C + \frac{Si}{30} + \frac{Mn}{20} + \frac{Cu}{20} + \frac{Ni}{60} + \frac{Cr}{20} + \frac{Mo}{15} + \frac{V}{10} + 5B \quad \%$$

**Table 1 : Plates - Condition of supply and number of impact tests**

Steel grade	Grain refining elements	Condition of supply (1)
EH36CAS1, EH36CAS2	Any	N (each piece), TM (each piece)
EH40CAS1, EH40CAS2	Any	N (each piece), TM (each piece), QT (each piece as heat treated)
EH47, EH47CAS1, EH47CAS2	Any	TM (each piece)
FH36CAS1, FH36CAS2 FH40CAS1, FH40CAS2	Any	N (each piece), TM (each piece), QT (each piece as heat treated)
<b>(1) Abbreviations:</b> N : Normalised Condition (heat treatment) TM : Thermo-Mechanical Rolling QT : Quenched and Tempered Condition.		

**Table 2 : EH47 and crack arrest steels - Chemical composition and deoxidation practice**

Steel grade	EH47	EH36CAS1, EH36CAS2 EH40CAS1, EH40CAS2 FH36CAS1, FH36CAS2 FH40CAS1, FH40CAS2	EH47CAS1, EH47CAS2
Deoxidation practice	killed and fine grain treated	Killed and fine grain treated	killed and fine grain treated
Chemical composition (%) <b>(3) (4)</b>			
C max.	0,18	0,18	0,18
Mn	0,90 - 2,00	0,90 - 2,00	0,90 - 2,00
Si max.	0,55	0,50	0,55
P max.	0,020	0,020	0,020
S max.	0,020	0,020	0,020
Al (acid soluble) min <b>(1) (2)</b>	0,015	0,015	0,015
Nb <b>(2)</b>	0,02 - 0,05	0,02 - 0,05	0,02 - 0,05
V <b>(2)</b>	0,05 - 0,10	0,05 - 0,10	0,05 - 0,10
Ti max. <b>(2)</b>	0,02	0,02	0,02
Cu max.	0,35	0,50	0,50
Cr max.	0,25	0,25	0,50
Ni max.	1,00	2,00	2,00
Mo max.	0,08	0,08	0,08
<b>(1)</b> The total aluminium content may be determined instead of the acid soluble content. In such cases the total aluminium content is to be not less than 0,020%. <b>(2)</b> The steel is to contain aluminium, niobium, vanadium or other suitable grain refining elements, either singly or in any combination. When used singly, the steel is to contain the specified minimum content of the grain refining element. When used in combination, the specified minimum content of a fine graining element is not applicable; the sum of Nb + V + Ti is not to exceed 0,12%. <b>(3)</b> Where additions of any other element have been made as part of the steelmaking practice subject to approval by the Society, the content is to be indicated on product inspection certificate <b>(4)</b> Variations in the specified chemical composition may be allowed or required by the Society and are to be stated at the approval.			

**Table 3 : Carbon equivalent and Pcm value for EH47 and crack arrest steels produced by TM process**

Steel grade	Carbon equivalent $C_{EQ}$ max. (%)	Pcm value max. (%)
EH36CAS1, EH36CAS2, FH36CAS1, FH36CAS2	0,47	<b>(1)</b>
EH40CAS1, EH40CAS2, FH40CAS1, FH40CAS2	0,49	<b>(1)</b>
EH47	0,49	0,22
EH47CAS1, EH47CAS2	0,55	0,24
<b>(1)</b> As per the approved specification.		

**Table 4 : Mechanical properties**

Steel grade	Yield stress $R_{eH}$ (N/mm <sup>2</sup> ) min.	Tensile strength $R_m$ (N/mm <sup>2</sup> )	Elong. $A_5$ (%) min.	Average impact energy (J) min. for thickness t (mm)									
				Test temp. (°C)	t ≤ 50		50 < t ≤ 70		70 < t ≤ 85		85 < t ≤ 100		
					KVL	KVT	KVL	KVT	KVL	KVT	KVL	KVT	
EH36CAS1, EH36CAS2 FH36CAS1, FH36CAS2	355	490/630	21	- 40	34	24	41	27	50	34	50	34	
				- 60	34	24	41	27	50	34	50	34	
EH40CAS1, EH40CAS2 FH40CAS1, FH40CAS2	390	510/660	20	- 40	39	26	46	31	55	37	55	37	
				- 60	39	26	46	31	55	37	55	37	
EH47 EH47CAS1, EH47CAS2	460	570/720	17	- 40	53		53		64		75		

**Table 5 : Requirements for crack arrest steels**

Suffix to the steel grade	Thickness range (mm)	Crack arrest properties	
		Crack arrest toughness $K_{ca}$ at -10°C (N/mm <sup>3/2</sup> ) (1)	Crack arrest temperature CAT (°C) (2)
CAS1	t ≤ 100	6000 min	-10 or below
CAS2	80 < t ≤ 100 (4)	8000 min	(3)

(1)  $K_{ca}$  value is to be obtained by the crack arrest test specified in ISO 20064-2019 and Appendix 1 of NR480  
(2) CAT is to be obtained by the test method specified in Appendix 2 of NR480.  
(3) Criterion of CAT for crack arrest steels corresponding to  $K_{ca}=8000\text{N/mm}^{3/2}$  is to be approved by the Society.  
(4) Lower thicknesses may be approved at the discretion of the Society.

**1.6 Mechanical properties**

1.6.1 The mechanical properties are indicated in Tab 4.

The condition of supply and the number of impact tests to be performed are indicated in Tab 1.

**1.7 Crack arrest properties**

1.7.1 The crack arrest properties for crack arrest steels are to be verified by either the crack arrest toughness  $K_{ca}$  or Crack Arrest Temperature (CAT) as specified in Tab 5.

**1.8 Mechanical tests**

**1.8.1 General**

Samples for mechanical tests are to be cut from the products in the final supply condition. The tests are to be carried out on individual pieces as required in [1.8.4] and [1.8.5].

**1.8.2 Individual testing**

The term piece means rolled unit as defined in Ch 1, Sec 1, [3.3.3].

**1.8.3 Sampling**

The specimens for tensile test are to be taken in the transverse direction and the specimens for the Charpy V-notch impact test in the longitudinal direction (KVL).

The impact test requirements specified on transverse specimens (KVT) are to be guaranteed by the manufacturer and random checks may be required by the Society.

Generally, impact tests are not required when the nominal product thickness is less than 6 mm.

Sampling positions are indicated in Sec 1, [8.1.2].

Additional through thickness tests may be required for special applications and are to be carried out according to the requirements of Sec 12.

**1.8.4 Number of tensile tests**

One tensile test is to be carried out from each piece.

**1.8.5 Number of impact tests**

The number of sets of impact tests required is indicated in Tab 1.

One set of three impact test specimens is required for each piece of steel grades EH and FH in all strengths.



# Section 5 Extra High Strength Steels for Welded Structures

## 1 Requirements

### 1.1 Scope

**1.1.1** The requirements of this Section apply to hot rolled, fine grain, weldable extra high strength steel plates, wide flats, sections, bars and seamless tubulars, intended for use in marine and offshore structural applications. These requirements do not apply to steels intended for ship hull structure.

**1.1.2** Provision is made for plates, sections, bars and seamless tubulars not exceeding thicknesses as specified in Tab 1.

**1.1.3** For thickness greater than the above, the steel grade specification may be accepted subject to the special approval of the Society.

**Table 1 : Maximum thickness limits**

Delivery condition	Maximum thickness (mm)			
	Plates	Sections	Bars	Tubulars
N	250	50	250	65
NR	150	<b>(1)</b>		
TM	150	50	N.A.	N.A.
QT	150	50	N.A.	50

N.A. = Not applicable.  
**(1)** The maximum thickness limits of sections, bars and tubulars produced by NR process route are less than those manufactured by N route, and shall be agreed with the Society.

### 1.2 Steel grades

**1.2.1** The steels are classed into eight groups indicated by minimum yield strength levels  $R_{eH}$  (N/mm<sup>2</sup>) 420, 460, 500, 550, 620, 690, 890 and 960.

Each group is further subdivided into four grades A, D, E and F based on the impact test temperature, except for yield strength levels 890 and 960 N/mm<sup>2</sup> for which grade F is not applicable.

The letters A, D, E and F mean impact test at 0°C, -20°C, -40°C and -60°C, respectively.

**1.2.2** Steels differing in chemical composition, deoxidation practice, conditions of supply and mechanical properties may be accepted, subject to special approval of the Society. Such steels are to have the letter "S" after the identification mark [e.g.E620S].

### 1.3 Manufacture

#### 1.3.1 Approval

The manufacturers are to be approved by the Society and the relevant requirements of Sec 1, [2] and Sec 1, [3] apply.

Provisions for the approval are given in NR480 "Approval of the manufacturing process of metallic materials".

#### 1.3.2 Steelmaking process

Vacuum degassing shall be used for all extra high strength steels of this Section with enhanced through thickness properties, and for steels grade with the minimum yield strength  $R_{eH} = 690\text{N/mm}^2$ .

#### 1.3.3 Deoxidation process and grain size

The steel is to be fully killed and fine grain treated.

The extra high strength steels shall have a fine grain structure containing sufficient amounts of nitrogen binding elements.

A fine grain structure has an equivalent index  $\geq 6$  determined by micrographic examination in accordance with ISO 643 or alternative test method.

#### 1.3.4 Reduction ratio

The maximum thickness of slab, billet or bloom from the continuous casting process shall be at the manufacturer's discretion.

Unless otherwise approved the total reduction ratio for products from slabs, billets, blooms or ingots is to be at least 3:1.

**1.3.5 Rolling practice**

Where NR and TM (with or without AcC) are applied, the programmed rolling schedules are to be submitted to the Society at the time of the approval and are to be made available when required by the attending Surveyor. On the manufacturer's responsibility, the programmed rolling schedules are to be adhered to during the rolling operation (as per Sec 1, [3.1.3]). To this effect, the actual rolling records are to be reviewed by the manufacturer and, occasionally, by the Surveyor.

When deviation from the programmed rolling schedules occurs, the manufacturer is to take further measures, to the Surveyor's satisfaction, in accordance with Sec 1, [3.1.3].

**1.3.6 Thickness tolerances and surface condition**

All materials are to be free from cracks, injurious surface flaws, injurious laminations and similar defects.

Unless otherwise agreed or specially required, tolerances on nominal thickness, surface condition and rectification of surface defects, the requirements are indicated in Sec 2, [1.3.4] or Sec 2, [1.3.5] and Sec 2, [1.4].

The surface quality inspection method shall be in accordance with recognized national or international standards agreed between the purchaser and the manufacturer.

- a) Welding repair procedures and the method for reporting repairs are to be approved by the Society.
- b) Where repair by grinding is carried out then the remaining plate thickness below ground area must be within the allowable under thickness tolerance.

Surface inspection is the responsibility of the manufacturer. The acceptance by the Surveyor of material later found to be defective shall not absolve the manufacturer of this responsibility.

**1.3.7 Non-destructive examination**

Ultrasonic testing of plates intended for offshore structural applications of first and special category as defined in the Society's Offshore Rules is required and is to be performed in accordance with a recognised standard (e.g. EN 10160 or ASTM A 578) and an examination level accepted by the Society.

Verification of the internal soundness is the responsibility of the manufacturer. The acceptance by the Surveyor shall not absolve the manufacturer of this responsibility.

**1.4 Condition of supply**

**1.4.1** The products are to be supplied in Normalised (N)/ Normalised Rolled (NR), Thermo-Mechanical controlled rolled (TM) or Quenched and Tempered (QT) condition as indicated in Tab 6.

The definition of supply condition is given in Sec 1, [7.1.3].

**1.5 Chemical Composition**

**1.5.1** The chemical composition is to be determined by the steelmaker in an adequately equipped and competently staffed laboratory. The method of sampling is to follow that carried out for the initial approval tests, either from the ladle, the tundish or the mould in the case of continuous casting.

The aim analysis is to comply with the approved specification. All elements listed in Tab 2 are to be reported.

The approved specification is to include the alloying, nitrogen binding, grain refining and residual elements, the maximum  $C_{EQ}$ /CET and the maximum Pcm value (cold cracking susceptibility index), agreed during the initial approval tests.

Unless otherwise agreed, the value of  $C_{EQ}$  is calculated by the following formula:

$$C_{EQ} = C + \frac{Mn}{6} + \frac{Cr + Mo + V}{5} + \frac{Ni + Cu}{15} \quad \%$$

For steel grade with the minimum yield strength 460N/mm<sup>2</sup>, CET may be used instead of  $C_{EQ}$  at the discretion of the manufacturer and is to be calculated using the following formula:

$$CET = C + \frac{Mn + Mo}{10} + \frac{Cr + Cu}{20} + \frac{Ni}{40} \quad \%$$

For TM and QT steels with carbon content not more than 0.12%, the cold cracking susceptibility Pcm for evaluating weldability may be used instead of carbon equivalent  $C_{EQ}$  or CET at manufacturer's discretion and is to be calculated using the following formula:

$$Pcm = C + \frac{Si}{30} + \frac{Mn}{20} + \frac{Cu}{20} + \frac{Ni}{60} + \frac{Cr}{20} + \frac{Mo}{15} + \frac{V}{10} + 5B \quad \%$$

The alloying and grain refining elements,  $C_{EQ}$ /CET and Pcm value, as applicable, are to be stated by the steelmaker and included in the testing documentation for each cast.  $C_{EQ}$ /CET and Pcm value are to comply with the requirements of Tab 3, Tab 4 and Tab 5.

**Table 2 : Chemical composition**

Delivery condition (1)	N/NR		TM		QT	
Steel grade	A/D420 A/D460	E420 E460	A/D420 A/D460 A/D500 A/D550 A/D620 A/D690 A890	E/F420 E/F460 E/F500 E/F550 E/F620 E/F690 D/E890	A/D420 A/D460 A/D500 A/D550 A/D620 A/D690 A890 A960	E/F420 E/F460 E/F500 E/F550 E/F620 E/F690 D/E890 D/E960
Chemical composition (%) (2)						
C max.	0,20	0,18	0,16	0,14	0,18	0,18
Mn	1,0 - 1,70	1,0 - 1,70	1,0 - 1,70	1,0 - 1,70	1,70	1,70
Si max.	0,60	0,60	0,60	0,60	0,80	0,80
P max. (3)	0,030	0,025	0,025	0,020	0,025	0,020
S max. (3)	0,025	0,020	0,015	0,010	0,015	0,010
Al total min. (4)	0,02	0,02	0,02	0,02	0,018	0,018
Nb max. (5)	0,05	0,05	0,05	0,05	0,06	0,06
V max. (5)	0,20	0,20	0,12	0,12	0,12	0,12
Ti max. (5)	0,05	0,05	0,05	0,05	0,05	0,05
Cu max.	0,55	0,55	0,55	0,55	0,50	0,50
Cr max. (5)	0,30	0,30	0,50	0,50	1,50	1,50
Ni max. (6)	0,80	0,80	2,00	2,00	2,00	2,00
Mo max. (5)	0,10	0,10	0,50	0,50	0,70	0,70
N max.	0,025	0,025	0,025	0,025	0,015	0,015
O ppm max. (7)	Not applicable	Not applicable	Not applicable	50	Not applicable	30

(1) See [1.4] for definition of delivery conditions.  
 (2) The chemical composition is to be determined by ladle analysis and shall meet the approved manufacturing specification at the time approval. When boron is deliberately added for enhancement of hardenability of the steels, the maximum boron content shall not be higher than 0,005%.  
 (3) For sections the P and S content can be 0,005% higher than the value specified in the table.  
 (4) The total aluminium to nitrogen ratio shall be a minimum of 2:1. When other nitrogen binding elements are used, the minimum Al value and Al/N ratio do not apply.  
 (5) Total Nb + V + Ti ≤ 0,26% and Mo + Cr ≤ 0,65%, not applicable for QT steels.  
 (6) Higher Ni content may be agreed with the Society.  
 (7) The requirement of maximum Oxygen content is only applicable to D890, E890, D960 and E960.

**Table 3 : Maximum carbon equivalent C<sub>EQ</sub> /CET and maximum P<sub>cm</sub> value for extra high strength steels produced by N/NR process**

Steel grade N/NR	C <sub>EQ</sub> (%)						CET (%)	P <sub>cm</sub> (%)
	Plates			Sections	Bars	Tubulars		
	t ≤ 50 mm	50 < t ≤ 100 mm	100 < t ≤ 250 mm	t ≤ 50 mm	t or d ≤ 250 mm	t ≤ 65 mm		
A420, D420, E420, F420	0,46	0,48	0,52	0,47	0,53	0,47	N.A.	N.A.
A460, D460, E460, F460	0,50	0,52	0,54	0,51	0,55	0,51	0,25	N.A.

N.A. = Not applicable

**Table 4 : Maximum carbon equivalent  $C_{EQ}$  /CET and maximum Pcm value for extra high strength steels produced by TM process**

Steel grade TM	$C_{EQ}$ (%)				CET (%)	Pcm (%)
	Plates			Sections		
	$t \leq 50$ mm	$50 < t \leq 100$ mm	$100 < t \leq 250$ mm	$t \leq 50$ mm		
A420, D420, E420, F420	0,43	0,45	0,47	0,44	N.A.	N.A.
A460, D460, E460, F460	0,45	0,47	0,48	0,46	0,30	0,23
A500, D500, E500, F500	0,46	0,48	0,50	N.A	0,32	0,24
A550, D550, E550, F550	0,48	0,50	0,54	N.A	0,34	0,25
A620, D620, E620, F620	0,50	0,52	N.A	N.A.	0,34	0,26
A690, D690, E690, F690	0,56	N.A.	N.A.	N.A.	0,36	0,28
A890, D890, E890	0,60	N.A.	N.A.	N.A.	0,38	0,28

N.A. = Not applicable

**Table 5 : Maximum carbon equivalent  $C_{EQ}$  /CET and maximum Pcm value for extra high strength steels produced by QT process**

Steel grade QT	$C_{EQ}$ (%)				CET (%)	Pcm (%)
	Plates			Tubulars		
	$t \leq 50$ mm	$50 < t \leq 100$ mm	$100 < t \leq 250$ mm	$t \leq 65$ mm		
A420, D420, E420, F420	0,45	0,47	0,49	0,46	N.A.	N.A.
A460, D460, E460, F460	0,47	0,48	0,50	0,48	0,32	0,24
A500, D500, E500, F500	0,48	0,50	0,54	0,50	0,34	0,25
A550, D550, E550, F550	0,56	0,60	0,64	0,56	0,36	0,28
A620, D620, E620, F620	0,56	0,60	0,64	0,58	0,38	0,30
A690, D690, E690, F690	0,64	0,66	0,70	0,68	0,40	0,33
A890, D890, E890	0,68	0,75	N.A.	N.A.	0,40	N.A.
A960, D960, E960	0,75	N.A.	N.A.	N.A.	0,40	N.A.

N.A. = Not applicable

## 1.6 Mechanical properties

**1.6.1** The mechanical properties are specified in Tab 6.

**1.6.2** For plates and sections for applications, such as racks in offshore platforms etc; where the design requires that tensile properties are maintained through the thickness, a decrease in the minimum specified tensile properties is not permitted with an increase in the thickness.

**Table 6 : Mechanical properties**

Steel grade	Delivery condition (1)	Yield stress $R_{eH}$ (N/mm <sup>2</sup> ) min. for thickness t (mm) (2)			Tensile strength $R_m$ (N/mm <sup>2</sup> ) for thickness t (mm)		Elongation $A_5$ (%) min. (3)		Average impact energy (J) min.		
		$3 \leq t \leq 50$	$50 < t \leq 100$	$100 < t \leq 250$	$3 \leq t \leq 100$	$100 < t \leq 250$	T	L	Test temp (C°)	KVT	KVL
A420 D420 E420 F420	N/NR or TM or QT	420	390	365	520-680	470-650	19	21	0 -20 -40 -60	28	42
A460 D460 E460 F460	N/NR or TM or QT	460	430	390	540-720	500-710	17	19	0 -20 -40 -60	31	46
A500 D500 E500 F500	TM or QT	500	480	440	590-770	540-720	17	19	0 -20 -40 -60	33	50
A550 D550 E550 F550	TM or QT	550	530	490	640-820	590-770	16	18	0 -20 -40 -60	37	55
A620 D620 E620 F620	TM or QT	620	580	560	700-890	650-830	15	17	0 -20 -40 -60	41	62
A690 D690 E690 F690	TM or QT	690	650	630	770-940	710-900	14	16	0 -20 -40 -60	46	69
A890 D890 E890	TM or QT	890	830	N.A.	940-1100	N.A.	11	13	0 -20 -40	46	69
A960 D960 E960	QT	960	N.A.	N.A.	980-1150	N.A.	10	12	0 -20 -40	46	69

(1) N: Normalising, NR: Normalising Rolling, TM: Thermo-Mechanical rolling, QT: Quenched and Tempered.  
 (2) When  $R_{eH}$  cannot be determined, the 0,2% proof stress (Rp0.2) value is to be determined. The material is considered to comply with the requirement if either value meets or exceeds the specified minimum value of yield strength.  
 (3) For full thickness flat test specimens having a width of 25mm and a gauge length of 200 mm, the elongation is to comply with the minimum values given in Tab 7. The tabulated elongation minimum values specified in Tab 7 are the requirements for testing specimens in transverse direction.  
 N.A. = Not applicable

**Table 7 : Minimum elongation values for flat specimens 25 mm width and 200 mm gauge length**

Strength level (1)	Thickness t (mm)						
	$t \leq 10$	$10 < t \leq 15$	$15 < t \leq 20$	$20 < t \leq 25$	$25 < t \leq 40$	$40 < t \leq 50$	$50 < t \leq 70$
420	11	13	14	15	16	17	18
460	11	12	13	14	15	16	17
500	10	11	12	13	14	15	16
550	10	11	12	13	14	15	16
620	9	11	12	12	13	14	15
690	9 (2)	10 (2)	11 (2)	11	12	13	14

(1) For strength levels 890 and 960, specimens which are not included in this table shall be proportional specimens with gauge length of:  
 $L_0 = 5,65 \sqrt{S_0}$   
 (2) For plates with thickness  $\leq 20$  mm and strength level 690, round specimen may be used instead of the flat tensile specimen. The minimum elongation for testing specimen in transverse direction is 14%.

## 1.7 Mechanical tests

### 1.7.1 General

Samples for tests are to be cut from the products in the final supply condition. The tests are to be carried out on each rolled unit as heat treated.

The definition of rolled unit is given in Ch 1, Sec 1, [3.3.3].

For continuously heat treated products, special sampling procedures may be agreed at the Society's discretion.

### 1.7.2 Sampling of tensile test specimen

The specimens for tensile test are to be taken with their longitudinal axes transverse to the final rolling direction, except in the case of sections, bars, tubulars and flats having finished width  $\leq 600$  mm, where the specimens may be taken in the longitudinal direction.

Full thickness flat tensile specimens are to be prepared in such manner as to maintain the rolling scale at least at one side. When the capacity of the test machine is exceeded by the use of the full thickness specimen, sub-sized flat tensile specimens representing either the full thickness or half of the product thickness retaining one rolled surface are to be used.

Alternatively, machined round test specimens may be used. The specimens are to be located at a position lying at a distance  $t/4$  from the surface and additionally at  $t/2$  for thickness above 100 mm or as near as possible to these positions.

Additional through thickness tests may be required for special application and are to be carried out according to the requirements of Sec 12. When required, through thickness tensile strength is not to be less than 80% of the specified minimum tensile strength.

### 1.7.3 Sampling of impact test specimen

In the case of plates and wide flats having finished width  $\geq 600$  mm, the impact test specimens are to be taken with their axes transverse to the final rolling direction.

In other cases the specimens are to be taken in the longitudinal direction, unless otherwise required by or agreed with the Society.

Sub-surface test specimens will be taken in such a way that one side is not further away than 2mm from a rolled surface.

For products with a thickness higher than 50 mm, impact tests shall be taken at the quarter thickness ( $t/4$ ) location and mid-thickness ( $t/2$ ) location.

Generally, impact tests are not required when the nominal product thickness is less than 6mm.

### 1.7.4 Number of tensile tests

Tensile test sample is to be randomly selected from each batch, as defined in Ch 1, Sec 1, [3.3.3] that is to be less than or equal to 25 tonnes, and to be from the same cast, in the same delivery condition and of the same thickness.

### 1.7.5 Number of impact tests

a) For steel plates in N/NR or TM condition, test sample is to be taken from each piece.

b) For steel plates in QT condition, test sample is to be taken from each individually heat treated part thereof.

c) For sections, bars and tubulars, test sample is to be taken from each batch of 25 tonnes or fraction thereof.

If the mass of the finished material is greater than 25 tonnes, one set of tests from each 25 tonnes and/or fraction thereof is required (e.g. for consignment of 60 tonnes would require 3 plates to be tested).

## 1.8 Marking

1.8.1 Each finished piece is to be clearly marked by the manufacturer as per Sec 1, [9] and with the following particulars:

a) Cast number/heat number, plate number or equivalent identification mark

b) Delivery condition (N/NR, TM/TM+AcC/TM+DQ or QT)

The entire markings are to be encircled with paint or otherwise marked so as to be easily recognized.

# Section 6 Steels for Boilers and Pressure Vessels

## 1 Requirements

### 1.1 Scope

**1.1.1** The requirements of this Section apply to weldable ferritic steel products (plates, flats, sections and bars) intended for boilers and pressure vessels.

Provision is made for products with thickness up to 60 mm and impact properties at a temperature not lower than  $-20^{\circ}\text{C}$ .

These requirements may also be applied to products with thickness above 60 mm subject to agreement with the Society.

**1.1.2** Special requirements may be specified in the case of applications intended for dangerous substances or particularly severe service conditions.

**1.1.3** In the case of applications involving the storage and transport of liquefied gases, reference is to be made to Society's Rules for the Classification of Steel Ships, NR467, Part D, Chapter 9 and to the International Code for the Construction and Equipment of Ships Carrying Liquefied Gases in Bulk (IGC Code).

For gas fuelled ships, reference is to be made to Society Rule Note NR529, and, to the International Code of Safety for Ships using Gases or other Low-flash point Fuels (IGF Code).

### 1.2 Steel grades

**1.2.1** The requirements apply to carbon and carbon manganese steels and low alloy steels (Mo and Cr-Mo steels).

**1.2.2** Carbon and carbon manganese steels are classed into four groups indicated by the minimum ultimate tensile strength  $R_m$  ( $\text{N}/\text{mm}^2$ ): 360, 410, 460 and 510.

Each group may be further subdivided into grades HA, HB and HD, as appropriate, based on the quality level and impact properties. The letters HA, HB and HD mean impact properties at  $+20^{\circ}\text{C}$ ,  $0^{\circ}\text{C}$  and  $-20^{\circ}\text{C}$ , respectively.

**1.2.3** Low alloy steels are designated according to the chemical composition into the grades 0,3Mo - 1Cr0,5Mo - 2,25Cr1Mo. Two types of 2,25Cr1Mo steel are specified in relation to the heat treatment and consequent mechanical properties.

The figures mean the nominal percentage content of the main alloying elements.

**1.2.4** In the case of liquefied gas carriers, plates and sections intended for cargo tanks and process pressure vessels with design temperature not lower than  $0^{\circ}\text{C}$ , the steel grades with letters HB may be selected for thicknesses up to 20mm included, and the steel grades with letters HD may be selected for thicknesses from 20mm to 40mm included, as applicable.

### 1.3 Manufacture

#### 1.3.1 Approval

Unless otherwise agreed by the Society, the manufacturers are to be approved and the relevant requirements of Sec 1, [2] and Sec 1, [3] apply.

Provisions for the approval are given in NR480 "Approval of the manufacturing process of metallic materials".

#### 1.3.2 Deoxidation process

The method of deoxidation is specified in Tab 1 and Tab 2.

#### 1.3.3 Rolling practice

Where CR (NR) are applied, the programmed rolling schedules are to be submitted to the Society at the time of the approval and are to be made available when required by the attending Surveyor. On the manufacturer's responsibility, the programmed rolling schedules are to be adhered to during the rolling operation (as per Sec 1, [3.1.3]). To this effect, the actual rolling records are to be reviewed by the manufacturer and, occasionally, by the Surveyor.

When deviation from the programmed rolling schedules occurs, the manufacturer is to take further measures, to the Surveyor's satisfaction, in accordance with Sec 1, [3.1.3].

#### 1.3.4 Thickness tolerances

Minus tolerances on the nominal thickness are not normally permitted.



**1.3.5 Rectification of surface defects by grinding**

Surface defects may generally be removed by grinding as indicated in Sec 1, [6.1.2], provided that the thickness, after grinding, is not less than the nominal thickness.

However the extent of repairs is to be agreed with the Surveyor. Where the thickness is reduced below the nominal thickness given in the approved plans, the possible acceptance and the relevant conditions are subject to special consideration by the Society.

**1.3.6 Rectification of surface defects by welding**

Defects which cannot be removed by grinding may generally be repaired by welding under the conditions given in Sec 1, [6.1.3], except that suitable heat treatment and non-destructive examination are always required after repair.

The purchaser is to be informed as to the extent and position of the repairs carried out on the individual plates.

**1.4 Condition of supply**

**1.4.1** The products are to be supplied in the conditions indicated in Tab 3 for carbon and carbon manganese steels and Tab 4 for low alloy steels.

**1.4.2** The products to be processed after supply by hot forming may also be supplied, where agreed, in the as rolled condition. In such cases heat treatment is to be carried out after hot forming and provision for the mechanical tests indicated in [1.8.4] is to be made.

**1.5 Chemical composition**

**1.5.1** The chemical composition on ladle analysis is to comply with the requirements specified in Tab 1 for carbon and carbon manganese steels and Tab 2 for low alloy steels and/or in the approved specification.

The approved specification is also to include the alloying and grain refining elements (not specified in Tab 1 and Tab 2).

The relevant elements as applicable are to be stated by the steelmaker and included in the testing documentation for each cast.

For C and C-Mn steels, an upper limit for carbon equivalent  $C_{EQ}$  on the ladle analysis may be specified at the time of approval of the individual steels.

Unless otherwise agreed, the value of  $C_{EQ}$  is calculated by the following formula:

$$C_{EQ} = C + \frac{Mn}{6} + \frac{Cr + Mo + V}{5} + \frac{Ni + Cu}{15} \%$$

Unless otherwise agreed, when a limit for  $C_{EQ}$  is required, the relevant values are to be stated by the steel-maker and included in the testing documentation for each cast.

**1.6 Mechanical properties**

**1.6.1** The mechanical properties are specified in Tab 3 for carbon and carbon manganese steels and Tab 4 for low alloy steels.

**Table 1 : Carbon and carbon manganese steels - Chemical composition**

Steel grade	Deoxidation	Chemical composition (%) (1)						
		C max	Mn	Si	P max	S max	Al tot. min. (1)	Ni max
360HA	not rimmed	0,16	≥ 0,40	≤ 0,35	0,030	0,030		
360HB	killed	0,16	0,40 - 1,20	0,10 - 0,35	0,030	0,030		
360HD	killed and fine grained	0,16	0,40 - 1,20	0,10 - 0,35	0,030	0,030	0,020	
410HA	not rimmed	0,20	≥ 0,50	≤ 0,35	0,030	0,030		0,30
410HB	killed	0,20	0,50 - 1,40	0,10 - 0,35	0,030	0,030		0,30
410HD	killed and fine grained	0,20	0,50 - 1,40	0,10 - 0,35	0,030	0,030	0,020	0,30
460HB	killed	0,20	0,80 - 1,50	0,10 - 0,40	0,030	0,030		0,30
460HD	killed and fine grained	0,20	0,80 - 1,50	0,10 - 0,40	0,030	0,030	0,020	0,30
510HB	killed	0,22	0,90 - 1,60	0,10 - 0,50	0,030	0,025		0,30
510HD	killed and fine grained	0,20	0,90 - 1,60	0,10 - 0,50	0,030	0,025	0,020	0,30

(1) Nb, V or Ti may be used for grain refining as a complete or partial substitute for Al. The grain refining elements are to be specified at the time of approval; in general Nb and V are not to exceed 0,05 and 0,10%, respectively. Additional alloying elements are to be submitted for consideration and approval. Residual elements not intentionally added are not to exceed the following limits:  
 Cu ≤ 0,30%; Cr ≤ 0,25%; Mo ≤ 0,10%. Total: Ni + Cu + Cr + Mo ≤ 0,70%



**Table 2 : Low alloy steels - Chemical composition**

Steel grade	Deoxidation (2)	Chemical composition (%) (1)						
		C	Mn	Si	P max	S max	Cr	Mo
0,3Mo	Si killed	0,12 - 0,20	0,40 - 0,90	0,10 - 0,35	0,030	0,030	≤ 0,30	0,25-0,35
1Cr 0,5Mo	Si killed	0,08 - 0,18	0,40 - 1,00	0,15 - 0,35	0,030	0,030	0,70-1,20	0,40-0,60
2,25Cr 1Mo	Si killed	0,07 - 0,15	0,40 - 0,80	0,15 - 0,50	0,030	0,030	2,00-2,50	0,90-1,10

(1) Residual elements are not to exceed the following limits: Cu ≤ 0,30%, Ni ≤ 0,30%.  
 (2) Aluminium total max 0,020% for all grades of steel. The aluminium content is to be mentioned in the ladle analysis certificate.

**Table 3 : Carbon and carbon manganese steels - Mechanical properties**

Steel grade	Heat treatment (1)	Yield stress R <sub>eH</sub> (N/mm <sup>2</sup> ) min. for thickness (mm)			Tensile strength R <sub>m</sub> (N/mm <sup>2</sup> )	Elong. A <sub>5</sub> (%) min.	Average impact energy (J) min.		
		t ≤ 16	16 < t ≤ 40	40 < t ≤ 60			Test temp (°C)	KVT	KVL
360HA	N or NR	215	205	195	360 - 480	25	+ 20	27	41
360HB 360HD		235	225	215			0		
							- 20		
410HA	N or NR	245	235	225	410 - 530	23	+ 20		
410HB 410HD		265	255	245			0		
							- 20		
460HB	N or NR	285	270	260	460 - 580	22	0		
460HD		295	285	280			- 20		
510HB	N or NR	345	335	325	510 - 630	21	0		
510HD		355	345	335			- 20		

(1) N: Normalising - NR: Normalising Rolling. As an alternative to normalising, the as rolled condition may be accepted for sections, subject to approval of individual steelmakers.

**Table 4 : Low alloy steels - Mechanical properties**

Steel grade	Heat treatment (1)	Yield stress R <sub>eH</sub> (N/mm <sup>2</sup> ) min. for thickness (mm)			Tensile strength R <sub>m</sub> (N/mm <sup>2</sup> )	Elongation A <sub>5</sub> (%) min. for thickness (mm)		Average impact energy (J) min. at + 20°C
		t ≤ 16	16 < t ≤ 40	40 < t ≤ 60		t ≤ 40	40 < t ≤ 60	
0,3Mo	N	275	270	260	430 - 600	24	23	31
1Cr 0,5Mo	N + T	300	295	295	450 - 610	20	19	
2,25Cr 0,5Mo	N + T	295	285	275	520 - 670	18	18	
	N+T or Q+T	310	310	310	470 - 620			

(1) N = Normalising; T = Tempering; Q = Quenching

**1.7 Mechanical properties at elevated temperatures**

**1.7.1** The values for the yield stress or 0,2% proof stress (R<sub>p0,2</sub>) at temperatures of 100°C and higher are given in Tab 5.

The above Table are for design purposes only. Their verification is in general not required during the testing, unless figures higher than those shown in the above Tables but in accordance with recognised standards are proposed by the steel manufacturer.

In such cases, the verification is required and the procedures detailed in [1.7.2] and [1.7.3] are to be followed.

**1.7.2** When R<sub>p0,2</sub> is required to be verified, at least one tensile test for each cast is to be carried out at the agreed temperature.

The sample is to be cut from the thickest plate of the cast and, if applicable, at the end of the plate that has shown the lowest figures in the tensile test at ambient temperature.

The sample is to be taken halfway between the edge and the axis of the piece, and the axis of the test specimen is to be located at one quarter of the thickness from one of the rolled surfaces.

The dimensions of the specimens and the testing procedure are to be in accordance with the requirements of Ch 2, Sec 2, [1.1] and Ch 2, Sec 2, [1.2.5], respectively.

The results of tests are to comply with the specified values.

**Table 5 : Minimum proof stress ( $R_{p0,2}$ ) values at elevated temperatures**

Steel grade	Thickness (mm)	$R_{p0,2}$ (N/mm <sup>2</sup> ) at a temperature (°C) of:										
		100	150	200	250	300	350	400	450	500	550	600
360HA (1)	≤ 16	175	172	168	150	124	117	115				
	> 16 ≤ 40	171	169	162	144	124	117	115				
	> 40 ≤ 60	162	158	152	141	124	117	115				
360HB (1) 360HD (1)	≤ 16	204	185	165	145	127	116	110				
	> 16 ≤ 40	196	183	164	145	127	116	110				
	> 40 ≤ 60	179	172	159	145	127	116	110				
410HA (1)	≤ 16	211	208	201	180	150	142	138				
	> 16 ≤ 40	201	198	191	171	150	142	138				
	> 40 ≤ 60	192	188	181	168	150	142	138				
410HB (1) 410HD (1)	≤ 16	235	216	194	171	152	141	134				
	> 16 ≤ 40	228	213	192	171	152	141	134				
	> 40 ≤ 60	215	204	188	171	152	141	134				
460HB (1) 460HD (1)	≤ 16	262	247	223	198	177	167	158				
	> 16 ≤ 40	260	242	220	198	177	167	158				
	> 40 ≤ 60	251	235	217	198	177	167	158				
510HB (1) 510HD (1)	≤ 60	290	270	255	235	215	200	180				
0,3Mo	≤ 60			215	200	170	160	150	145	140		
1Cr 0,5Mo	≤ 60			230	220	205	190	180	170	165		
2,25Cr 1Mo	≤ 60 (2)			235	230	220	210	200	190	180		
	≤ 60 (3)			265	255	235	225	215	205	195		

(1) The values at  $R_{p0,2}$  for temperatures ≤ 250°C are for guidance only  
(2) Normalised and tempered  
(3) Normalised and tempered or quenched and tempered

**1.7.3** As an alternative to the systematic verification of the required  $R_{p0,2}$  as in [1.7.2], it may be agreed with the individual steelmakers to carry out an adequate program of tests on the normal production for each type of steel to be approved.

For manufacturers and steel types approved on this basis, tensile tests at elevated temperatures are not generally required during the routine testing of the material supplied; they may be required by the Society as a random check for the confirmation of the approval.

**1.7.4** For design purposes only, the estimated values of the stress to rupture in 100000 hours are given in Tab 6 for groups of steels.

## 1.8 Mechanical tests

### 1.8.1 General

Unless otherwise agreed (see [1.8.6]), samples for tests are to be cut from the products in the final supply conditions.

### 1.8.2 Samples from plates and wide flats

The tests are to be carried out on each rolled unit as heat treated.

One sample is to be taken from one end of each rolled unit when the mass and the length do not exceed 5t and 15m, respectively.

When either of these limits is exceeded, samples are to be cut at both ends of each rolled unit.

The definition of rolled unit is given in Ch 1, Sec 1, [3.3.3].

### 1.8.3 Samples from sections and bars

One sample is to be taken from each batch homogeneous for cast, section size and condition of supply. Each batch is to contain not more than 50 pieces and its total mass is not to exceed 10 t.

### 1.8.4 Sampling of test specimens

In the case of plates and wide flats having width ≥ 600 mm, the tensile test and impact test specimens are to be taken in the transverse direction.

In other cases the specimens are to be taken in the longitudinal direction, unless otherwise required by or agreed with the Society.

**Table 6 : Average values for stress to rupture in 100000 hours (N/mm<sup>2</sup>)**

Temperature (°C)	Steel grade				
	360 - 410	460 - 510	0,3Mo	1Cr 0,5Mo	2,25Cr 1Mo
380	170	225			
390	155	200			
400	140	175			
410	125	155			
420	110	135			
430	100	115			
440	90	100			
450	75	85	235	285	220
460	(60)	(70)	205	250	205
470	(50)	(60)	175	220	185
480	(40)	(55)	145	190	170
490		(45)	120	160	150
500		(40)	100	135	135
510			80	120	120
520			65	95	105
530			50	80	90
540				60	75
550				50	65
560				40	55
570				30	50
580					45
590					(40)
600					(35)

**Note 1:** The values shown are estimated average values; the lower limit of the range is approximately 20% less than the average value. The values in brackets for some higher temperatures indicate that the steel is not suitable for continuous use at such temperatures.

**1.8.5 Number of test specimens**

The following test specimens are to be taken from each sample:

- a) 1 tensile test specimen (2 tests in the case of bars intended for tie rods)
- b) 1 set of 3 Charpy V-notch impact test specimens (only for grades HB and HD unless otherwise specified)
- c) 1 tensile test specimen at elevated temperature, for each cast, when required.

**1.8.6 Material intended for hot working**

When material is intended for hot working, it is agreed that the required heat treatment will be carried out by the purchaser. In such case, the testing samples are to be heat treated by the steelmaker before cutting the test specimens.

In particular cases like material to be submitted to cold or hot working during fabrication, tests additional to the routine testing may be required on samples in the final condition of the material after fabrication.

These may also include tests on material submitted to artificial aging treatment as indicated in Ch 2, Sec 7, [1.1.1].

# Section 7 Ferritic Steels for Low Temperature Service

## 1 Requirements

### 1.1 Scope

**1.1.1** The requirement of this Section apply to ferritic steel products (plates, flats, sections and bars) intended for cargo tanks, storage tanks, process pressure vessels and systems for liquefied gases and other pressure vessels in general, when impact properties at temperature lower than  $-20^{\circ}\text{C}$  are required.

Provision is made for products with thickness up to 60mm.

The extension to higher thicknesses and relevant conditions are subject to agreement with the Society.

**1.1.2** Special requirements may be specified in the case of applications intended for dangerous substances or particularly severe service conditions.

**1.1.3** In case of applications involving the storage and transport of liquefied gases, reference is to be made to Society's Rules for the Classification of Steel Ships, NR467, Part D, Chapter 9 and to the International Code for the Construction and Equipment of Ships Carrying Liquefied Gases in Bulk (IGC Code).

For gas fuelled ships, reference is to be made to Society Rule Note NR529, and, to the International Code of Safety for Ships using Gases or other Low-flash point Fuels (IGF Code).

### 1.2 Steel grades

**1.2.1** The requirements apply to carbon, carbon manganese, Ni steels.

**1.2.2** The carbon and carbon manganese steels are classed into six groups indicated by the minimum ultimate tensile strength  $R_m$  (N/mm<sup>2</sup>): 390, 410, 460, 490, 510 and 550.

Each group may be further subdivided into three grades, LE, LF or LT, as appropriate, based on the quality level and impact properties.

The letters LE and LF mean impact properties at  $-40^{\circ}\text{C}$  and  $-60^{\circ}\text{C}$ , respectively.

The letters LT mean impact properties at temperature between  $-55^{\circ}\text{C}$  and  $-70^{\circ}\text{C}$ , depending on the thickness.

**1.2.3** Ni steels are designated according to the chemical composition into the grades: 1,5Ni - 2,25Ni - 3,5Ni - 5Ni - 9Ni. The figures mean the Ni nominal percentage content.

**1.2.4** In the case of liquefied gas carriers, plates and sections intended for cargo tanks, secondary barriers and process pressure vessels with design temperatures not lower than  $-50^{\circ}\text{C}$ , the steel grades 390LT and 490LT may be selected as per Tab 4, as applicable.

**1.2.5** In the case of liquefied gas carriers, plates and sections intended for cargo tanks, secondary barriers and process pressure vessels with design temperatures lower than  $-55^{\circ}\text{C}$ , nickel steels may be selected as per Tab 5, depending on the design temperature, as applicable.

### 1.3 Manufacture

#### 1.3.1 Approval

The manufacturers are to be approved by the Society and the relevant requirements of Sec 1, [2] and Sec 1, [3] apply.

Provisions for the approval are given in NR480 "Approval of the manufacturing process of metallic materials".

#### 1.3.2 Deoxidation process

The steel is to be killed and fine grained.

#### 1.3.3 Thickness tolerances

For pressure vessels, minus tolerances on nominal thickness are not normally permitted.

#### 1.3.4 Surface conditions

For repairs, the provisions of Sec 6, [1.3.5] and Sec 6, [1.3.6] apply.

Repairs by welding are not normally allowed on 5% or 9% nickel steels and high manganese austenitic steel.

**1.4 Condition of supply**

**1.4.1** Unless otherwise accepted by the Society, carbon and carbon manganese products are to be supplied in normalised (N) condition.

Nickel steel products are to be supplied in the conditions indicated in Tab 5.

High manganese austenitic steel products is to be hot rolled and subsequent controlled cooling if necessary.

**1.4.2** The products to be processed after supply by hot working may also be supplied, where agreed, in the as rolled condition. In such cases heat treatment is to be carried out after forming and provision for the mechanical tests indicated in Sec 6, [1.8.6] is to be made.

**1.5 Chemical composition**

**1.5.1** The chemical composition on ladle analysis is to comply with the requirements specified in Tab 1 and Tab 2 and/or in the approved specification.

The approved specification is also to include the alloying and grain refining elements (not specified in Tab 1 and Tab 2).

The content of the above elements, as applicable, is to be stated by the steelmaker for each heat and included in the testing documentation.

For C and C-Mn steels, an upper limit for carbon equivalent  $C_{EQ}$  on the ladle analysis may be specified at the time of approval of the individual steels.

Unless otherwise agreed, the value of  $C_{EQ}$  is calculated by the following formula:

$$C_{EQ} = C + \frac{Mn}{6} + \frac{Cr + Mo + V}{5} + \frac{Ni + Cu}{15} \quad \%$$

Unless otherwise agreed, when a limit for  $C_{EQ}$  is required the relevant values are to be stated by the steelmaker and included in the testing documentation for each cast.

**Table 1 : Carbon and carbon manganese steels - Chemical composition**

Steel grade	Chemical composition (%) (1)						
	C max	Mn	Si	P max	S max	Al tot min	Ni max
410 LE	0,18	0,50 - 1,40	0,10 - 0,35	0,030	0,030	0,020	0,30
410 LF	0,16	0,50 - 1,40	0,10 - 0,35	0,030	0,030	0,020	0,80
460 LE	0,18	0,80 - 1,50	0,10 - 0,40	0,030	0,030	0,020	0,30
460 LF	0,16	0,80 - 1,50	0,10 - 0,40	0,030	0,030	0,020	0,80
510 LE	0,18	1,00 - 1,70	0,10 - 0,50	0,030	0,025	0,020	0,30
510 LF	0,16	1,00 - 1,70	0,10 - 0,50	0,030	0,025	0,020	0,80
550 LE	0,18	1,00 - 1,70	0,10 - 0,50	0,030	0,025	0,020	0,30
550 LF	0,16	1,00 - 1,70	0,10 - 0,50	0,030	0,025	0,020	0,80
390 LT	0,16	0,80 - 1,50	0,10 - 0,40	0,030	0,025	0,020	1,25
490 LT	0,16	1,00 - 1,70	0,10 - 0,50	0,030	0,025	0,020	1,25

(1) Nb, V or Ti may be used for grain refining as a complete or partial substitute for Al. The grain refining elements are to be specified at the time of approval; in general Nb and V are not to exceed 0,05 and 0,10%, respectively. Additional alloying elements are to be submitted for consideration and approval. Residual elements not intentionally added are not to exceed the following limits (%): Cu ≤ 0,30, Cr ≤ 0,15, Mo ≤ 0,10.

**Table 2 : Nickel steels - Chemical composition**

Steel grade	Chemical composition (1) (2)							
	C max	Mn	Si max	P max	S max	Ni	Cr max	Mo max
1,5 Ni	0,18	0,30 - 1,50	0,35	0,035	0,020	1,30 - 1,70	0,25	0,10
2,25 Ni	0,17	0,30 - 0,90	0,35	0,035	0,020	2,10 - 2,50	0,25	0,10
3,5 Ni	0,15	0,30 - 0,90	0,35	0,035	0,020	3,20 - 3,80	0,25	0,10
5,0 Ni	0,12	0,30 - 0,90	0,35	0,035	0,020	4,70 - 5,30	0,25	0,10
9,0 Ni	0,10	0,30 - 0,90	0,35	0,035	0,020	8,50 - 10,0	0,25	0,10

(1) Residual elements are not to exceed the following limits (%): Cu ≤ 0,35; V ≤ 0,05. Total Cr + Cu + Mo ≤ 0,50

(2) Aluminium total not less than 0,020 for all grades of steels. The aluminium content is to be mentioned in the ladle analysis certificate.

1.6 Mechanical properties

1.6.1 The products are to comply with the mechanical properties specified in, Tab 3 Tab 4 and Tab 5.

**Table 3 : Carbon and carbon manganese steels - Mechanical properties**

Steel grade	Yield stress $R_{eH}$ (N/mm <sup>2</sup> ) min. for thickness t (mm)			Tensile strength $R_m$ (N/mm <sup>2</sup> )	Elong. $A_5$ (%) min	Average impact energy (J) min.		
	t ≤ 16	16 < t ≤ 40	40 < t ≤ 60			Temp (°C)	KVT	KVL
410 LE	265	255	245	410 - 530	23	- 40	27	41
410 LF	290	280	270	410 - 530	23	- 60	27	41
460 LE	295	285	270	460 - 580	22	- 40	27	41
460 LF	320	310	300	460 - 580	22	- 60	27	41
510 LE	355	345	335	510 - 630	21	- 40	27	41
510 LF	355	345	335	510 - 630	21	- 60	27	41
550 LE	390	380	375	550 - 670	20	- 40	27	41
550 LF	390	380	375	550 - 670	20	- 60	27	41

**Table 4 : Carbon and carbon manganese steels - Mechanical properties**

Steel grade	Yield stress $R_{eH}$ (N/mm <sup>2</sup> ) min. for thickness t (mm)		Tensile strength $R_m$ (N/mm <sup>2</sup> )	Elongation $A_5$ (%) min	Average impact energy (J) min.			
	t ≤ 16	16 < t ≤ 40			Thickness (mm)	Temp (°C)	KVT	KVL
390 LT	275	265	390 - 510	24	t ≤ 25	- 55	27	41
					25 < t ≤ 30	- 60		
					30 < t ≤ 35	- 65		
					35 < t ≤ 40	- 70		
490 LT	355	345	490 - 630	22	t ≤ 25	- 55	27	41
					25 < t ≤ 30	- 60		
					30 < t ≤ 35	- 65		
					35 < t ≤ 40	- 70		

**Note 1:** These requirements are applicable to products with thickness up to 40mm. For thicknesses exceeding 40 mm, the requirements shall be agreed with the Society.

**Table 5 : Nickel steels - Mechanical properties**

Steel grade	Heat treatment (1)	Yield stress $R_{eH}$ (N/mm <sup>2</sup> ) min.	Tensile strength $R_m$ (N/mm <sup>2</sup> )	Elongation $A_5$ (%) min.	Average impact energy (J) min.			
					Thickness (mm)	Temp (°C)	KVT	KVL
1,5 Ni	N+T or Q+T	275	490 - 640	22	t ≤ 25	- 65	27	41
					25 < t ≤ 30	- 70		
					30 < t ≤ 35	- 75		
					35 < t ≤ 40	- 80		
2,25 Ni	N+T or Q+T	275	490 - 640	22	t ≤ 25	- 70	27	41
					25 < t ≤ 30	- 75		
					30 < t ≤ 35	- 80		
					35 < t ≤ 40	- 85		
3,5 Ni	N+T or Q+T	285	450 - 610	21	t ≤ 25	- 95	27	41
					25 < t ≤ 30	- 100		
					30 < t ≤ 35	- 105		
					35 < t ≤ 40	- 110		
5,0 Ni	N+T or Q+T	390	540 - 740	21	t ≤ 25	- 110	27	41
					25 < t ≤ 30	- 115		
					30 < t ≤ 35	- 120		
					35 < t ≤ 40	- 125		
9,0 Ni	N+N+T or Q+T	490	640 - 790	18	t ≤ 40	- 196	27	41

(1) N = normalising; T = tempering; Q = quenching.

**Note 1:** These requirements are applicable to products with thickness up to 40mm. For thicknesses exceeding 40 mm, the requirements shall be agreed with the Society.

### 1.7 Mechanical tests

#### 1.7.1 General

Unless otherwise agreed in the case of materials to be hot worked after delivery [1.4.2], samples for tests are to be cut from the products in the final supply condition.

#### 1.7.2 Samples from plates and wide flats

The tests are to be carried out on each rolled unit as heat treated.

One sample is to be taken from one end of each rolled unit when the mass and the length do not exceed 5t and 15m, respectively. When either of these limits is exceeded, samples are to be cut at both ends of each rolled unit.

The definition of rolled unit is given in Ch 1, Sec 1, [3.3.3].

#### 1.7.3 Samples from sections and bars

One sample is to be taken from each batch homogeneous for heat, section size and condition of supply.

Each batch is to contain not more than 50 pieces and its total mass is not to exceed 10 t.

#### 1.7.4 Sampling of test specimens

In the case of plates and wide flats having width  $\geq 600\text{mm}$ , the tensile test and impact test specimens are to be taken in the transverse direction.

In other cases the specimens are to be taken in the longitudinal direction, unless otherwise required by or agreed with the Society.

#### 1.7.5 Number of test specimens

The following test specimens are to be taken from each sample:

- a) 1 tensile test specimen
- b) 1 set of 3 Charpy V-notch impact test specimens
- c) 2 or more drop weight test specimens, when required.

# Section 8 Steels for Machinery

## 1 Requirements

### 1.1 Scope

**1.1.1** The requirements of this Section apply to carbon, carbon manganese, low alloy and alloy rolled steel products intended for use in the construction of structures and parts of machinery and equipment operating at ambient temperature.

In the case of applications in low or high temperature pressure systems, reference is to be made to the applicable requirements of Sec 7 and Sec 6 respectively.

**1.1.2** The products are grouped as follows, depending on the application:

- structural parts of deck equipment
- welded machinery structures such as bedplates, crankcases, frame entablatures or similar items
- rolled products, such as bars for small shafts, pins, bolts or similar items, when, in the limit of diameters of 250mm, they are accepted in lieu of forgings.

### 1.2 Steel grades and relevant properties

**1.2.1** The type of steels covered by Sec 2, Sec 6, Sec 7 and Sec 9 may be used as appropriate.

Chemical and mechanical properties are to comply with the requirements given therein.

For products having thickness exceeding the maximum thickness considered in the above-mentioned Sections, the following deviations in mechanical properties are permitted:

- the minimum yield stress  $R_{eH}$  required is reduced by 1% for every 5 mm thickness over the a.m. maximum
- the minimum elongation  $A_5$  min. required is reduced by 1 unit for thickness over than the a.m. max up to 100 mm and by 2 units for thickness greater than 100 mm.

### 1.3 Manufacture and condition of supply

**1.3.1** Products intended for applications under [1.1.2] a) and [1.1.2] b) are to be manufactured and supplied as indicated in Sec 2, [1.3] and Sec 2, [1.6], Sec 6, [1.3] and Sec 6, [1.4], Sec 7, [1.3] and Sec 7, [1.4], as appropriate.

For products intended for applications under [1.1.2] c), the applicable requirements of Chapter 5 apply; unless otherwise agreed, a reduction ratio of 6:1 in respect of the original ingot is generally required.

**1.3.2** For specific applications, ultrasonic examinations in accordance with approved standards or procedures may be required.

Rolled bars for shaft lines, used in lieu of forgings and having a diameter higher than 150 mm, are to be submitted to non-destructive (ultrasonic and magnetoscopic) examinations.

**1.3.3** Unless otherwise agreed or specially required, the minus tolerances on nominal thickness indicated in Tab 1 apply to plates and wide flats.

**Table 1 : Minus tolerances on nominal thickness**

Nominal thickness t (mm)	Minus tolerance (mm)
$3 \leq t < 5$	-0,3
$5 \leq t < 8$	-0,4
$8 \leq t < 15$	-0,5
$15 \leq t < 25$	-0,6
$25 \leq t < 40$	-0,7
$40 \leq t < 80$	-0,9
$80 \leq t < 150$	-1,1
$150 \leq t < 250$	-1,2
$t \geq 250$	-1,3



### 1.4 Mechanical tests

**1.4.1** For applications under [1.1.2] a) and [1.1.2] b), irrespective of the grade of steel, the testing may be in batches in accordance with the relevant requirements of Sec 2.

One tensile test is to be carried out from one piece for each batch presented or fraction thereof.

Unless otherwise required, the impact tests may be omitted.

**1.4.2** For applications under [1.1.2] c), the testing procedure is to be in accordance with the requirements of Ch 5, Sec 1, [7.4.1] relevant to forgings.

**1.4.3** The results of tensile and impact tests are to comply with requirements of Sec 2, Sec 6 and Sec 7, Sec 9, as applicable.

# Section 9 Stainless Steel Products

## 1 Requirements

### 1.1 Scope

**1.1.1** The requirements of this Section apply to austenitic and austenitic-ferritic (duplex) rolled stainless products intended for use in construction of cargo tanks, storage tanks and pressure vessels for chemicals and limitedly to the austenitic grades for liquefied gases.

**1.1.2** Austenitic stainless steels are suitable for use both at elevated and low temperatures.

When austenitic stainless steels are proposed for use at elevated temperatures, details of chemical composition, heat treatment and mechanical properties are to be submitted for consideration and approval.

Unless otherwise specified, austenitic-ferritic stainless steels are in general suitable for design temperature between  $-20^{\circ}\text{C}$  and  $+275^{\circ}\text{C}$ .

**1.1.3** Stainless steel bars may be used for propeller shafts or similar applications under the conditions given in Sec 8, [1.1.2] c).

**1.1.4** In cases of applications involving the storage and transport of liquefied gases, reference is to be made to Society's Rules for the Classification of Steel Ships, NR467, Part D, Chapter 9 and to the International Code for the Construction and Equipment of Ships Carrying Liquefied Gases in Bulk (IGC Code).

For gas fuelled ships, reference is to be made to Society Rule Note NR529, and to the International Code of Safety for Ships using Gases or other Low-flash point Fuels (IGF Code).

### 1.2 Steel grades

**1.2.1** The requirements apply to Cr-Ni austenitic and austenitic-ferritic stainless steels.

Note 1: Reference is made for designation to the corresponding AISI grade.

Other stainless steel of martensitic types, in accordance with international or national standards, may be accepted for specific applications such as in [1.1.3].

### 1.3 Manufacture

#### 1.3.1 Approval

Unless otherwise agreed, the manufacturers of steel intended for the construction of cargo tanks, storage tanks and pressure vessels for chemicals and liquefied gases are to be approved by the Society and the relevant requirements of Sec 1, [2] and Sec 1, [3] apply. Provisions for the approval are given in NR480 "Approval of the manufacturing process of metallic materials".

#### 1.3.2 Corrosion resistance

The resistance of tank material to cargoes is under the responsibility of the yard.

Justification of such resistance is to be submitted to the Society.

#### 1.3.3 Thickness tolerances

With the exception of pressure vessels (see Sec 6, [1.3.4]), the minus tolerance on nominal thickness is to be 0,3 mm.

#### 1.3.4 Surface conditions

Surface defects may be removed by grinding, provided that the plate thickness at the location of the ground zone is not less than the minimum thickness specified in [1.3.3].

Surface defects which cannot be removed by grinding may be generally repaired under the conditions given in Sec 2, [1.4.4], as applicable.

### 1.4 Condition of supply

**1.4.1** All materials are to be supplied in the solution treated condition.

### 1.5 Chemical composition

**1.5.1** The chemical composition on ladle analysis is to comply with the requirements specified in Sec 10, Tab 1.

### 1.6 Mechanical properties

**1.6.1** The mechanical properties are specified in Tab 2.

**Table 1 : Chemical composition**

AISI grade designation	Chemical composition (%) (1)								
	C max	Mn max	Si max	P max	S max	Cr	Ni	Mo	Others
Austenitic									
304 L	0,030	2,0	1,0	0,040	0,030	17,0 - 19,0	8,0- 12,0	–	
304 LN	0,030	2,0	1,0	0,040	0,030	17,0 - 19,0	8,5 - 11,0	–	0,14 ≤ N ≤ 0,22
316 L	0,030	2,0	1,0	0,040	0,030	16,0 - 18,5	10,0 - 14,0	2,0 - 3,0	
316 LN	0,030	2,0	1,0	0,040	0,030	16,0 - 18,5	10,0 - 14,0	2,0 - 3,0	0,14 ≤ N ≤ 0,22
317 L	0,030	2,0	1,0	0,040	0,030	18,0 - 20,0	14,0 - 16,0	3,0 - 4,0	
317 LN	0,030	2,0	1,0	0,040	0,030	18,0 - 20,0	12,5 - 14,0	3,0 - 4,0	0,14 ≤ N ≤ 0,22
321	0,080	2,0	1,0	0,040	0,030	17,0 - 19,0	9,0 - 13,0	–	5xC ≤ Ti ≤ 0,80
347	0,080	2,0	1,0	0,040	0,030	17,0 - 19,0	9,0 - 13,0	–	10xC ≤ Nb ≤ 0,80
Duplex austenitic-ferritic									
UNS S 31803	0,030	2,0	0,75	0,035	0,010	21,0 - 23,0	4,5 - 6,5	2,5 - 3,5	0,10 ≤ N ≤ 0,22
UNS S 32550	0,030	2,0	0,75	0,035	0,010	24,0 - 26,0	5,5 - 7,5	2,7 - 3,9	1,0 ≤ Cu ≤ 2,0
UNS S 32750	0,030	2,0	0,80	0,035	0,020	24,0 - 26,0	6,0 - 8,0	3,0 - 5,0	Cu ≤ 0,50
(1) With the exception of refining elements, additional alloying elements are to be submitted for consideration and approval. Residual elements are permitted provided they do not impair the properties, subsequent processing or behaviour in service of the material.									

**Table 2 : Mechanical properties**

AISI grade designation	Yield strength (N/mm <sup>2</sup> ) min. (1)		Tensile strength R <sub>m</sub> (N/mm <sup>2</sup> )	A <sub>5</sub> (%) min.	Average impact energy (J) min.	
	R <sub>p0,2</sub>	R <sub>p1,0</sub>			KVL	KVT
Austenitic					at –196°C	at –196°C
304 L	175	215	470 - 670	45	41	27
304LN	270	310	570 - 790	40		
316L	195	235	490 - 690	45		
316LN	300	340	≥ 590	45		
317L	195	235	490 - 690	40		
317LN	300	340	≥ 590	45		
321	205	245	500 - 750	40		
347	205	245	500 - 750	40		
Duplex austenitic-ferritic					at –20°C	at –20°C
UNS S31803	≥ 470		660 - 800	25	41	27
UNS S32550	≥ 490		690 - 890	25		
UNS S32750	≥ 530		730 - 930	25		
(1) The yield strength R <sub>p0,2</sub> is in general to be determined						

**1.7 Mechanical tests**

**1.7.1 Samples from plates and wide flats for cargo tanks, secondary barriers and process pressure vessels of liquefied gas carriers**

Samples for tests are to be cut from the products in the final supply condition. The tests are to be carried out on each rolled unit as heat treated.

One sample is to be taken from one end of each rolled unit when the mass and the length do not exceed 5t and 15m, respectively.

When either of these limits is exceeded, samples are to be cut at both ends of each rolled unit.

The definition of rolled unit is given in Ch 1, Sec 1, [3.3.3].

### 1.7.2 Samples from plates and wide flats for other applications

The products are grouped in batches of 20 tonnes or fraction thereof, consisting of parts coming from the same cast, the thickness of which differs by no more than 5mm in the case of flat products.

When the batch is made up of plates, the plate selected to take the test specimens is to be one of those of highest thickness.

### 1.7.3 Samples from sections and bars

The products are grouped in batches of 20 tonnes or fraction thereof, consisting of parts coming from the same cast, the thickness of which differs by no more than 5mm.

### 1.7.4 Sampling of test specimens

In the case of plates and wide flats having width  $\geq 600$  mm, the tensile test and impact test specimens are to be taken in the transverse direction.

In other cases the specimens are to be taken in the longitudinal direction, unless otherwise required by or agreed with the Society.

### 1.7.5 Number of test specimens

The following tests are to be carried out:

- a) one tensile test at ambient temperature
- b) unless otherwise required, 3 Charpy V-notch impact tests at:
  - $-196^{\circ}\text{C}$  for austenitic steels intended for use in constructions with design temperature lower than  $-105^{\circ}\text{C}$
  - $-20^{\circ}\text{C}$  for austenitic-ferritic steels.

## 1.8 Metallographic structure

**1.8.1** When required, a metallographic structure examination is to be carried out on sections parallel to the rolling direction of the product, and taken over the whole thickness of the product.

The examination is to be performed with magnification 200x.

No detrimental intermetallic phase (sigma phase) is to appear in appreciable quantity.

## 1.9 Intergranular corrosion test

**1.9.1** When required, an intergranular corrosion test is to be carried out in compliance with standard ASTM A262 Practice E, or other recognised standards.

The test is to reveal no sensitivity to intergranular corrosion.

## 1.10 Through thickness tests

**1.10.1** Where improved through thickness ductility is required, through thickness tests are to be performed but are generally not required for grades 304L, 304LN, 321 and 347.

**1.10.2** Tests and results are to be in accordance with the requirements of Sec 12 and [1.10.3].

**1.10.3** When the reduction in area is between 25 and 35 per cent, additional metallographic examination or other evidence is required to show that no significant amount of any detrimental phase, such as sigma, is present.

# Section 10 High Manganese Austenitic Steel

## 1 Requirements

### 1.1 Scope

**1.1.1** The requirement of this Section apply to high manganese austenitic steel products intended for cargo tanks, storage tanks, process pressure vessels and systems for liquefied gases.

Provision is made for products with thickness up to 40 mm.

The extension to higher thicknesses and relevant conditions are subject to agreement with the Society.

**1.1.2** Special requirements may be specified in the case of applications intended for dangerous substances or particularly severe service conditions.

**1.1.3** In case of applications involving the storage and transport of liquefied gases, reference is to be made to Society's Rules for the Classification of Steel Ships, NR467, Part D, Chapter 9 and to the International Code for the Construction and Equipment of Ships Carrying Liquefied Gases in Bulk (IGC Code).

For gas fuelled ships, reference is to be made to Society Rule Note NR529, and, to the International Code of Safety for Ships using Gases or other Low-flash point Fuels (IGF Code).

### 1.2 Steel grades

**1.2.1** High manganese austenitic steel means the steel with a high amount of manganese in order to retain austenite as its primary phase at atmospheric and service temperature.

**1.2.2** The grade is identified by the prefix HMA, followed by a number giving the minimum specified ultimate tensile strength  $R_m$  (N/mm<sup>2</sup>).

### 1.3 Manufacture

#### 1.3.1 Approval

The manufacturers are to be approved by the Society and the relevant requirements of Sec 1, [2] and Sec 1, [3] apply.

Provisions for the approval are given in NR480 "Approval of the manufacturing process of metallic materials".

#### 1.3.2 Deoxidation process

The steel is to be fully killed and fine grained.

#### 1.3.3 Thickness tolerances

For pressure vessels, minus tolerances on nominal thickness are not normally permitted.

#### 1.3.4 Surface conditions

For repairs, the provisions of Sec 6, [1.3.5] apply. Repairs by welding are not allowed.

### 1.4 Condition of supply

**1.4.1** Unless otherwise accepted by the Society, high manganese austenitic steel products are to be supplied in hot rolled condition and subsequent controlled cooling if necessary.

**1.4.2** The reduction ratio of slab to finished product thickness is to be not less than 3:1.

### 1.5 Chemical composition

**1.5.1** The chemical composition on ladle analysis is to comply with the requirements specified in Tab 1 and/or in the approved specification.

The approved specification is also to include the alloying and grain refining elements (not specified in Tab 1).

### 1.6 Mechanical properties

**1.6.1** The products are to comply with the mechanical properties specified in Tab 2.

**Table 1 : High manganese austenitic steel - Chemical composition**

Steel grade	Chemical composition (%) (1)								
	C	Mn	Si	P max	S max	Cr	B max	N max	Cu
HMA 400	0,35 - 0,55	22,50-25,50	0,10-0,50	0,030	0,010	3,00 - 4,00	0,005	0,050	0,30-0,70

(1) The content of other elements used for alloying and fine grain treatment are to be submitted for approval. Si content may be less than 0,1%, provided total aluminium is 0,03% or higher, or provided acid soluble aluminium is 0,025% or higher.

**Table 2 : High manganese austenitic steel - Mechanical properties**

Steel grade	Yield stress R <sub>eH</sub> (N/mm <sup>2</sup> ) min.	Tensile strength R <sub>m</sub> (N/mm <sup>2</sup> )	Elong. A <sub>5</sub> (%) min	Average impact energy (J) min.		
				Temp (°C)	KVT	KVL
HMA 400	400	800 - 970	22	- 196	27	41

**1.7 Mechanical tests**

**1.7.1 General**

Samples for tests are to be cut from products in the final supply condition. The tests are to be carried out on each rolled unit as heat treated.

The definition of rolled unit is given in Ch 1, Sec 1, [3.3.3].

Sample positions are indicated in Ch 1, Sec 1, [3.3.3].

**1.7.2 Sampling of test specimens**

In the case of plates and wide flats having width ≥ 600mm, the tensile test and impact test specimens are to be taken in the transverse direction.

In other cases the specimens are to be taken in the longitudinal direction, unless otherwise required by or agreed with the Society.

The Charpy V-notch impact test specimens are to be taken with their longitudinal axis as near as practicable to a point midway between the surface and the center of the thickness.

**1.7.3 Number of test specimens**

The following test specimens are to be taken from each sample:

- a) 1 tensile test specimen
- b) 1 set of 3 Charpy V-notch impact test specimens

# Section 11 Clad Steel Plates

## 1 Requirements

### 1.1 Scope

**1.1.1** The requirements of this Section apply to clad steel plates consisting of a base material “backing steel” and a thinner stainless steel layer “cladding steel” on one or both sides, continuously and integrally bonded, by hot rolling or by explosion bonding.

Provision is made for plates having total thickness higher than 5mm; unless otherwise accepted by the Society, the thickness of the cladding metal is to be  $\geq 2$ mm.

### 1.2 Steel grades

**1.2.1** The grade of the backing steel is to be chosen from the steel grades for boilers and pressure vessels defined in Sec 6. Other backing steel grades may be accepted subject to the Society’s approval.

**1.2.2** The cladding metal in austenitic or austenitic-ferritic stainless steel is to correspond to the grades defined in Sec 9. The use of other grades for stainless steel cladding is to be proposed to the Society for prior approval.

### 1.3 Manufacture

#### 1.3.1 Approval

Clad steel plate manufacturing process is to be approved by the Society and the conditions for approval are indicated in the document NR480 “Approval of the manufacturing process of metallic materials”.

#### 1.3.2 Surface condition and dimensional tolerances

The manufacturer is responsible for examination of the surface condition, as well as the compliance with the dimensions and the tolerances. However the Surveyor may require to have the cladding surface presented for visual examination.

### 1.4 Condition of supply

**1.4.1** The plates are to be supplied in the same heat treatment condition as stated during the approval.

### 1.5 Chemical composition

**1.5.1** Works’ certificates for backing and cladding steels stating the chemical composition are to be supplied by the manufacturer.

### 1.6 Mechanical properties

**1.6.1** The mechanical properties of the backing material are to comply with the requirements given in Sec 6. The check of the mechanical properties of the cladding material is not required.

### 1.7 Mechanical tests

#### 1.7.1 Batch composition

The batch is to be composed of plates having the same overall thickness, cladding thickness and cast of backing steel, and mass not exceeding 20 t.

#### 1.7.2 Number of tests

The following tests are to be performed:

- 1 tensile test on the full clad plate
- 2 bend tests on the full clad plate
- 1 series of impact tests on the backing steel
- 1 shear test on the cladding.

#### 1.7.3 Tensile test

During the tensile test of the full clad plate, the strength is to be not less than the value given by the following formula:

$$R = \frac{R_b \cdot t_b + R_c \cdot t_c}{t}$$

where:

- $R_b$  : Nominal minimum  $R_{eH}$  or  $R_m$  of backing material  
 $R_c$  : Nominal minimum  $R_{eH}$  or  $R_m$  of cladding material  
 $t_b$  : Nominal thickness of backing material  
 $t_c$  : Nominal thickness of cladding material  
 $t$  : Nominal thickness of the full clad plate.

If the values resulting from the tensile test (yield stress, ultimate tensile strength) are lower than those given by the above formula, one additional test is to be performed after removal of the cladding material.

During the tests the requirements for the backing material are to be satisfied.

The value of elongation specified for the backing material applies also to the full clad plate.

#### **1.7.4 Bend tests**

The bending conditions (mandrel diameter in general 3 times the plate thickness) are those required for the backing steel grade. One bend test is carried out with the cladding metal on the tensioned side (outer side of bend) and another with the cladding metal on the compressed side (inner side of bend). In the latter test, separations of the cladding not exceeding 25% of the bent portion are admitted.

#### **1.7.5 Shear test**

The shear test is carried out in accordance with ASTM A 264. The shear strength is to be at least 140 N/mm<sup>2</sup>.

### **1.8 Corrosion testing**

**1.8.1** When required, an accelerated corrosion test is to be carried out to check the resistance of the cladding metal against intergranular corrosion. This corrosion test may be carried out according to a national or an international standard, or to a particular specification, in agreement with the Society. ASTM A 262 practice E may be used.

### **1.9 Ultrasonic testing**

**1.9.1** Ultrasonic testing of the adhesion of the cladding is generally to be performed on plates with an overall thickness (backing + cladding) equal to or greater than 10mm. For overall thickness less than 10mm, the ultrasonic testing procedure is to be defined in agreement with the Society.

**1.9.2** The ultrasonic testing is to be performed with the following procedures:

- peripheral inspection of a strip of 50 mm in width on all the plate edges
- continuous testing according to a grid with square meshes, 200 mm long and parallel to the plate edges.

Random checks may be required by the Surveyor.

**1.9.3** The reflection technique is used, with a normal probe having a diameter ranging from 20 to 35 mm and a frequency from 3 to 5 MHz.

**1.9.4** Unless otherwise agreed with the Society, non-adhesion areas which do not exceed (50 mm x 50 mm) are acceptable without repair, provided that they are at least 500 mm apart.

### **1.10 Surface defects and repairs**

**1.10.1** Surface defects may be accepted by the Surveyor when they are not detrimental to the proper use of the product and its corrosion resistance.

**1.10.2** All the surface defects are to be ground so as to restore the surface continuity. Nevertheless, such repair by grinding is admitted only if the remaining thickness of the cladding is at least equal to its guaranteed nominal thickness.

**1.10.3** In cases where, after grinding, the cladding thickness is less than the guaranteed nominal thickness, the repair is carried out by welding. The filler metal is to be of the same grade as the cladding and the repair procedure is to be defined in agreement with the Surveyor and preliminarily approved.

**1.10.4** If, after grinding of the defect, the remaining thickness of the cladding is less than half of the guaranteed nominal thickness, it is necessary to replace the cladding by tapering and to rebuild the whole of the cladding by welding. Such repair is to be carried out in agreement with the Surveyor and preliminarily approved.

### **1.11 Adhesion defects in the cladding and repairs**

**1.11.1** In the case of adhesion defects detected by an ultrasonic testing as defined in [1.9], the areas of non-adhesion of the cladding which exceed the limits specified in [1.9.4] are to be removed by cutting off or to be repaired.



# Section 12 Steels with Specified Through Thickness Properties

## 1 Requirements

### 1.1 Scope

**1.1.1** The requirements of this Section apply to steel plates and wide flats having thickness not less than 15mm, where improved through thickness ductility in the direction of thickness is required.

The extension to lower thicknesses and relevant conditions are at the discretion of the Society.

### 1.2 Steel grades

**1.2.1** The requirements of Sec 12 are intended as a supplement to the requirements of Sec 2, Sec 3, Sec 4, Sec 5, Sec 6, Sec 7, Sec 8 and Sec 9 which specify the quality grade of steels for hull structures, cargo oil tanks, upper deck region of container ships, boilers, pressure vessels, low temperature applications and machinery.

**1.2.2** The Z designation is to be given to any steel grade which has been tested according to the above mentioned specifications, and has been successfully subjected to the tests defined in [1.6] and [1.7].

### 1.3 Manufacture

#### 1.3.1 Approval

Any Z grade steel must be submitted to the approval of the Society.

The conditions for approval are indicated in the document NR480 "Approval of the manufacturing process of metallic materials".

### 1.4 Chemical composition

**1.4.1** In addition to the requirements of the appropriate steel grade, the maximum sulphur content is to be 0,008% determined by the ladle analysis.

### 1.5 Mechanical properties

**1.5.1** The ductility in the direction of thickness is evaluated, for the purpose of these requirements with the value of the reduction area measured on tensile test specimens taken in the through thickness direction of the product and prepared as specified in [1.7.3].

### 1.6 Mechanical tests

#### 1.6.1 Plates and wide flats

Plates and wide flats are to be tested by rolled unit or by batch in accordance with the conditions mentioned in Tab 1.

**Table 1 : Batch size dependent on product and sulphur content**

Product	S > 0,005%	S ≤ 0,005%
Plates	Each piece (parent plate)	Maximum 50 t of products of the same cast, thickness and heat treatment
Wide flats of nominal thickness ≤ 25 mm	Maximum 10 t of products of the same cast, thickness and heat treatment	Maximum 50 t of products of the same cast, thickness and heat treatment
Wide flats of nominal thickness > 25 mm	Maximum 20 t of products of the same cast, thickness and heat treatment	Maximum 50 t of products of the same cast, thickness and heat treatment

### 1.7 Test preparation

**1.7.1** The sample is to be taken close to the longitudinal centreline of one end of the rolled piece to be tested as shown in Fig 1. The sample must be large enough for the preparation of six specimens. Three specimens are to be prepared while the rest of the sample remains for possible retest.

Figure 1 : Plate and wide flat sampling position

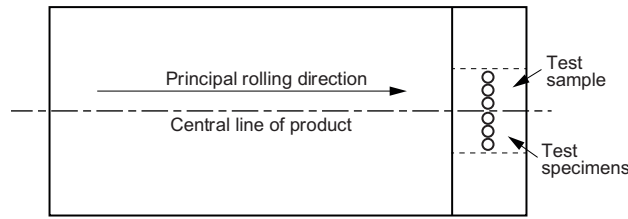

1.7.2 Cylindrical tensile test specimens are to be used having the following dimensions:

- a) diameter:
  - $d = 6\text{ mm}$  for product thickness between 15 mm and 25 mm
  - $d = 10\text{ mm}$  for product thickness exceeding 25 mm
- b) parallel length: not less than  $2d$ .

Other dimensions are to be according to ISO 6892-1:2019 or other recognised standards.

Where the product thickness does not allow the preparation of specimens of sufficient length for the gripping jaws of the testing machine, the ends of the specimens may be built up by suitable welding methods in such a way as to not impair the portion of the specimen within the parallel length.

1.7.3 The preparation of samples is indicated in Fig 2 and Fig 3.

Figure 2 : Normal test specimen

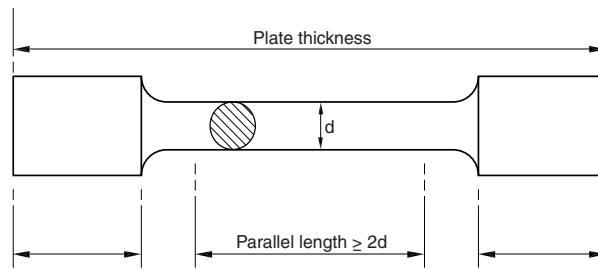
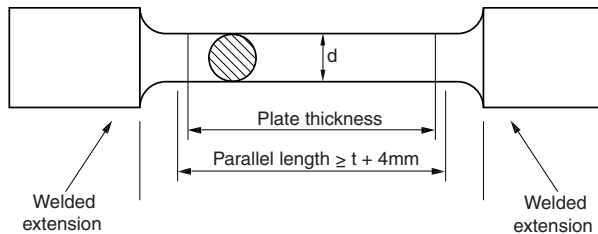

Figure 3 : Welded test specimen



1.8 Test results

1.8.1 The three tensile test specimens taken in the through thickness direction are to be tested at ambient temperature. The minimum average value for the reduction of area must be that shown for the appropriate grade given in Tab 2. Only one individual value may be below the minimum average but not less than minimum individual value shown for the appropriate grade. A value less than the minimum individual is a cause for rejection.

Table 2 : Reduction of area acceptance values

Grade	Z25	Z35
Minimum average	25%	35%
Minimum individual	15%	25%

1.9 Re-test

1.9.1 Three additional test specimens taken from the remaining test sample can be prepared and tested in three cases shown in Fig 4. The average of all six tensile tests is to be greater than the required minimum average with no more than two results below the minimum average.

In the case of failure after retest, either the batch represented by the piece is rejected or each piece within the batch is required to be tested.

Figure 4 : Diagram showing acceptance / rejection and retest criteria

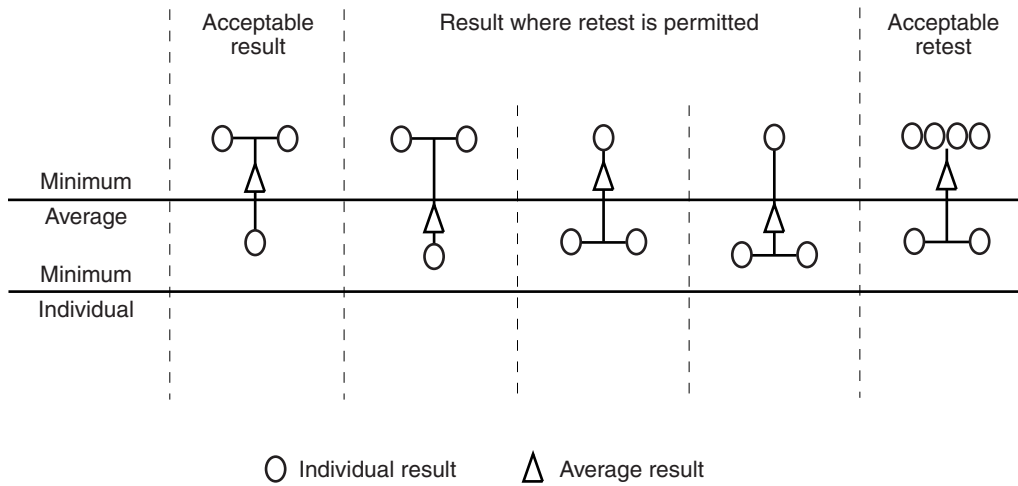

### 1.10 Ultrasonic testing

1.10.1 Ultrasonic testing is required and is to be performed in accordance with either EN10160:1999 Level S1/E1 or ASTM A578:2017 Level C. Ultrasonic testing is to be carried out on each piece in the final supply condition and unless otherwise agreed with a probe frequency of 4MHz.

### 1.11 Marking

1.11.1 In addition to the material grade designation, products complying with these requirements are to be marked with the letter Z followed by the indication of the reduction of area required, e.g.: EH 36-Z 25.

## CHAPTER 4 STEEL PIPES, TUBES AND FITTINGS

---

Section 1	General Requirements
Section 2	Pipes for Pressure Systems Operating at Ambient Temperature
Section 3	Pipes for Structural Applications
Section 4	Extra High Strength Steel Pipes for Welded Structure
Section 5	Pipes for High Temperature Service
Section 6	Ferritic Steel Pipes for Pressure Service at Low Temperature
Section 7	Austenitic and Austenitic-Ferritic Stainless Steel Pipes
Section 8	Fittings

# Section 1 General Requirements

## 1 Scope

### 1.1 General

**1.1.1** The requirements of this Chapter apply to seamless and welded steel pipes, tubes and fittings intended for boilers, pressure vessels and systems operating at ambient, high or low temperature.

Provision is also made for pipes intended for structural applications, at ambient temperature.

Sec 1 specifies the requirements common to all the above-mentioned steel pipes, while the appropriate specific requirements are indicated in Sec 2 to Sec 8.

The general term pipes will be used in the following text to mean pipes and tubes.

### 1.2 Other specifications

**1.2.1** Seamless and welded pipes and fittings complying with international, national or proprietary specifications may be accepted by the Society, provided such specifications give reasonable equivalence to the requirements of these Rules and other relevant Society's Rules or are approved for a specific application.

Such products, when accepted are designated by their standard identification or as agreed at the time of the approval.

Unless otherwise agreed, survey and certification of products complying with other specifications are to be carried out in accordance with the requirements of these Rules and other relevant Society's Rules.

### 1.3 Special requirements

**1.3.1** Special requirements may be specified in cases of applications intended for dangerous substances or particularly severe service conditions.

In cases of applications involving the storage and transport of liquefied gases, reference is to be made to Society's Rules for the Classification of Steel Ships, NR467, Part D, Chapter 9 and to the International Code for the Construction and Equipment of Ships Carrying Liquefied Gases in Bulk (IGC Code).

For gas fuelled ships, reference is to be made to Society Rule Note NR529, and to the International Code of Safety for Ships using Gases or other Low-flash point Fuels (IGF Code).

## 2 Manufacturing

### 2.1 Steelmaking and pipe manufacturing

**2.1.1** The steel used is to be manufactured as detailed in Ch 3, Sec 1, [2.1.1].

Unless a specific method is agreed for individual supplies, or specific requirements are given in the relevant Articles, the pipes may be manufactured by one of the following methods:

- a) seamless, hot or cold finished
- b) welded, by automatic processes
- c) welded, as above hot and/or cold finished.

In the case of welded pipes, the following processes are to be used depending on the grade of steel:

- a) electrical resistance (ERW), induction (IW), submerged arc (SAW) welding for carbon and carbon manganese steels
- b) electric tungsten arc process (GTAW), plasma (PAW), submerged (SAW) arc welding for austenitic or austenitic-ferritic steels.

The welding process is to be approved according to the applicable requirements of Chapter 12.

Unless specially approved by the Society, pipes in carbon and carbon-manganese steel for offshore structural applications are to be seamless or longitudinally welded.

Nickel steel pipes are to be manufactured seamless.

Unless otherwise specified, the manufacturing process is left to the discretion of the Manufacturer.

## 3 Approval

### 3.1 Pipe manufacturing process

**3.1.1** Welded pipes and fittings and, unless otherwise specified by the Society, seamless pipes and fittings in low alloyed or alloyed steels, intended for high temperature are to be manufactured by approved Manufacturers.

In other cases the Manufacturers are in any event to be recognised by the Society.

The approval procedure is indicated in the document NR480 "Approval of the manufacturing process of metallic materials".

### 4 Quality of materials

#### 4.1 General requirements

**4.1.1** All pipes are to have a workmanlike finish consistent with the method of manufacture and to be free from defects and surface or internal imperfections which may impair their use in subsequent fabrication or service.

**4.1.2** All pipes are to be reasonably straight and their ends are to be cut perpendicular to the axis without leaving chips or burrs.

### 5 Visual, dimensional and non-destructive examinations

#### 5.1 General requirements

**5.1.1** Each pipe is to be submitted by the Manufacturer to visual examination and verification of dimensions.

Reference is made to the general provisions given in Ch 1, Sec 1, [3.6].

**5.1.2** The dimensional tolerances on the thickness and diameter are to be in accordance with recognised standards.

In welded pipes, the weld reinforcement is to be well faired and within allowable limits.

**5.1.3** Welded pipes are to be submitted by the Manufacturer to an appropriate, automatic non-destructive test of welded joints as defined at the approval.

### 6 Rectification of surface defects

#### 6.1 Rectification of surface defects by grinding

**6.1.1** Small surface defects and imperfections may be removed by grinding, provided that the pipe thickness after repair is within the permissible tolerance and the ground zone is well faired into the adjacent zone.

#### 6.2 Rectification of surface defects by welding

**6.2.1** Repairs by welding may be accepted at the Surveyor's discretion. The repair procedure is to be submitted for consideration. The repaired areas are subsequently to be examined by magnetic particle or liquid penetrant methods and/or by other appropriate non-destructive tests.

### 7 Condition of supply

#### 7.1 General requirements

**7.1.1** Pipes are to be supplied in the required heat treated or equivalent condition.

Where alternative supply conditions are accepted, the choice of the supply condition, unless otherwise required, is left to the Manufacturer; the condition of supply is always to be mentioned in the testing documentation.

**7.1.2** Pipes which are to be expanded after supply are to be annealed at least at their ends.

### 8 Hydrostatic test

#### 8.1 Testing conditions

**8.1.1** With the exception of pipes intended for structural application, each pipe is to be subjected to hydrostatic test at the Manufacturer's works.

The test pressure  $P$ , in  $N/mm^2$ , is given by the following formula but the maximum pressure may not be higher than  $14 N/mm^2$ :

$$P = \frac{2tf}{D}$$

where:

$D$  : Nominal outside diameter of the pipe, in mm

$t$  : Nominal wall thickness of the pipe, in mm

$f$  : Equal to:

- $0,80 R_{eH}$  for ferritic steels
- $0,70 R_{p0,2}$  for austenitic or austenitic-ferritic steels.

The test pressure is to be maintained for a sufficient time to verify the tightness and at least for 5 seconds.

The test pressure is to be measured by means of a suitable, calibrated pressure gauge.

**8.1.2** Unless otherwise agreed, the Manufacturer’s certificate of the hydrostatic test is accepted.

The hydrostatic test of pipes intended for boilers, super heaters or pressure systems with working pressure higher than 4,0 N/mm<sup>2</sup>, or conveying liquefied gases and dangerous media, may be required to be witnessed by the Surveyor.

**8.1.3** Subject to the prior approval of the procedure, a non-destructive test by ultrasonic or eddy current may be accepted as an alternative to the hydrostatic test.

## 9 Sampling and testing

### 9.1 Batch composition

**9.1.1** Pipes are to be presented for mechanical and technological tests in the final supply condition and, unless otherwise indicated in the relevant Articles, in batches.

For pipes which are not heat treated, the batch is to consist of pipes of the same size, manufactured by the same procedure, from the same type of steel.

For pipes which are supplied in the heat treated condition, the batches are to consist of pipes of the same size, manufactured from the same type of steel and subjected to the same heat treatment in a continuous furnace or heat treated in the same furnace charge.

For pipes welded by the electric submerged arc welding process, the batch is also to consist of pipes welded with the same welding materials.

For pipes intended for low temperature service, the batch is also to consist of material originating from the same cast.

The size of the batch is to be in accordance with Tab 1.

**Table 1 : Number of pipe as made lengths per batch**

Outside diameter range (mm)	Maximum number of tubes per batch (1)
D ≤ 114,3	200
114,3 < D ≤ 323,9	100
323,9 < D	50

(1) Residual quantities of up to 10 lengths may be allocated to the other batches presented for testing.

### 9.2 Sampling

**9.2.1** The test samples are to be cut from a length selected at random from each batch, for the tests specified in the various Sections.

The specimens for all or part of the following tests, as detailed in the various Sections, are to be obtained from the individual samples.

a) Mechanical tests

- tensile test, longitudinal direction
- tensile test transverse to the weld for pipes with D ≥ 300 mm
- 3 Charpy V-notch impact tests, longitudinal direction.

For subsize specimens, reference is to be made to Ch 2, Sec 4, [1.2.2]. For pipes having thickness less than 6 mm, reduced specimens having the maximum thickness are to be used.

b) Technological tests

- Flattening test

For welded pipes, two tests are to be carried out; in one test the specimen is to be positioned with the welded joint at 0°, in the other at 90°, to the direction of the force.

The distance between plates to be reached during the test is determined by the following formula:

$$Z = \frac{(1 + C)t}{C + \frac{t}{D}}$$

where the value of C is indicated in the tables relevant to the mechanical properties of the various pipes

- A bend test is to be performed in lieu of the flattening test for pipes having D > 400 mm or thickness greater than 15% of D  
For welded pipes, one test is carried out with the outside surface of the pipe in tension and the other with the inside surface of the pipe in tension. The mandrel diameter is indicated in the various Sections and the bend angle is to be equal to 180°
- Flanging or drift expanding test for pipes having D ≤ 150 mm and thickness ≤ 10 mm.

### **9.3 Preparation of test specimen**

**9.3.1** For the preparation of test specimens and for the testing procedures, reference is to be made to the applicable requirements of Chapter 2.

### **9.4 Tensile and technological tests**

**9.4.1** The results of the test are to comply with the values specified in the appropriate tables.

If during the tensile test there is no marked yield stress  $R_{eH}$ , the 0,2% proof stress  $R_{p0,2}$  is taken as an alternative.

### **9.5 Impact test**

**9.5.1** The average value is to comply with the minimum average value required; only one individual value may be less than the average value required, provided that it is not less than 70% of it. The values required for the various products are relevant to standard specimens 10x10 mm<sup>2</sup>.

For subsize specimens reference is to be made to Ch 2, Sec 4, [1.2.2].

For reduced specimens obtained from pipes having thickness less than 6 mm, the energy required is proportional to the area of the specimen, referring to the specimen 10 x 5 mm<sup>2</sup> and to the energy required for this specimen.

### **9.6 Re-test procedures**

**9.6.1** Reference is made to Ch 1, Sec 1, [3.5].

For tensile re-test procedure, reference is made to Ch 2, Sec 2, [1.3].

For Charpy V-notch re-test procedure, reference is made to Ch 2, Sec 4, [1.4].

## **10 Identification and marking**

### **10.1 General requirements**

**10.1.1** The Manufacturer is to adopt a system of identification which enables the material to be traced to its original cast, as appropriate.

**10.1.2** All pipes and tubes are to be identified and marked with the following indications:

- a) Society's brand
- b) Manufacturer's name or trade mark
- c) Identification mark for the type of steel
- d) Cast number or identification number and/or letters, which will enable the history of the fabrication of the piece or bundle to be traced.

Marking is to be applied by punching. In the case of small wall thickness which may be damaged by punching, alternative methods such as paint, electrical engraving or rubber stamps may be used.

Marking on labels is accepted for small pipes, see Ch 1, Sec 1, [4.1.2].

## **11 Documentation and certification**

### **11.1 General requirements**

**11.1.1** The testing documentation indicated in Ch 1, Sec 1, [4.2.1] is to be issued and is to include all the required information, as appropriate.

The ladle analysis is to include the content of refining and alloying elements as applicable.

If rimming steel is supplied, this condition is to be stated on the certificate.

**11.1.2** When pipes are made from steel produced in a mill other than that where the pipes are manufactured, the Surveyor is to be supplied with a steelmaker's certificate stating the manufacturing process, the grade of steel, the cast number and the relevant ladle analysis.



# Section 2 Pipes for Pressure Systems Operating at Ambient Temperature

## 1 Requirements

### 1.1 Scope

**1.1.1** The requirements of this Section apply to seamless and welded carbon and carbon manganese steel pipes, intended for piping systems or pressure vessels operating at ambient temperature or when impact properties at a temperature not lower than  $-20^{\circ}\text{C}$  are specified.

### 1.2 Steel grades

**1.2.1** The requirements apply to carbon and carbon manganese steels, which are classed into five groups indicated by the minimum ultimate tensile strength  $R_m$ , in  $\text{N/mm}^2$ : 320, 360, 410, 460 and 510.

Each group is further subdivided into grades HA, HB and HD, based on quality level and impact properties, as applicable.

The letters HA, HB and HD mean impact properties at  $+20^{\circ}\text{C}$ ,  $0^{\circ}\text{C}$  and  $-20^{\circ}\text{C}$ , respectively.

### 1.3 Condition of supply

**1.3.1** Seamless cold finished pipes are to be normalised, while hot finished pipes may be normalised or normalised formed.

Welded pipes are to be supplied in the condition specified at the approval.

At the Manufacturer's discretion, normalising and tempering may be carried out in lieu of normalising; see Sec 1, [7].

### 1.4 Chemical composition

**1.4.1** The method of deoxidation and chemical composition on ladle analysis are to comply with the requirements specified in Tab 1.

### 1.5 Mechanical properties

**1.5.1** The mechanical properties are specified in Tab 2.

**Table 1 : Chemical composition**

Steel grade	Deoxidation	Chemical composition (%) (1)					
		C max	Mn	Si max	P max	S max	Al tot. min. (1)
320 HA	semi-killed or killed (2)	0,16	0,40 - 0,70	0,35	0,040	0,040	
360 HA 360 HB	semi-killed or killed	0,17	0,40 - 1,00	0,35	0,040	0,040	
410 HB	killed	0,21	0,40 - 1,20	0,35	0,040	0,040	
410 HD	killed and fine grained						0,020
460 HB	killed	0,22	0,80 - 1,40	0,35	0,040	0,040	
460 HD	killed and fine grained						0,020
510 HB	killed	0,22	0,60 - 1,80	0,35	0,035	0,035	
510 HD	killed and fine grained						0,020

(1) Nb, V or Ti may be used for grain refining as a complete or partial substitute for Al. The grain refining elements are to be specified at the time of approval; in general Nb and V are not to exceed 0,05 and 0,10%, respectively.  
Additional alloying elements are to be submitted for consideration and approval. Residual elements not intentionally added are not to exceed the following limits (%): Ni  $\leq$  0,30; Cu  $\leq$  0,25; Cr  $\leq$  0,25; Mo  $\leq$  0,10. Total: Ni + Cu + Cr + Mo  $\leq$  0,70

(2) For welded pipes, rimmed steel may also be used, as specified at the approval.

**Table 2 : Mechanical properties**

Steel grade	Yield stress $R_{eH}$ (N/mm <sup>2</sup> ) min. for thickness t (mm)			Tensile strength $R_m$ (N/mm <sup>2</sup> )	Elong. $A_5$ (%) min.	Average impact energy (J) min.		Technological tests		
	t ≤ 16	16 < t ≤ 40	40 < t ≤ 60			Test temp (°C)	KVL	Flattening test constant C for t/D		Bend test diameter mandrel
								t/D ≤ 0,15	t/D > 0,15	
320HA	195			320 - 440	25	+20	27	0,09	0,08	4 t
360HA	235	225	215	360 - 500	24	+20				
360HB						0				
410HB	255	245	235	410 - 550	22	0		0,07	0,06	
410HD						-20				
460HB	285	275	265	460 - 580	21	0				
460HD						-20				
510HB	355	345	(1)	510 - 630	19	0	34			
510HD						-20				

(1) To be agreed between Manufacturer and purchaser.

**1.6 Mechanical and technological tests**

**1.6.1** For pipes intended for pressure cylinders, the tests are to be carried out on each as made length.

Pipes intended for other applications are to be presented in batches, as specified in Sec 1, Tab 1.

One pipe is to be selected from each batch for the required tests as follows:

a) seamless pipes:

- one tensile test, longitudinal direction
- one flattening test or one bend test
- 3 Charpy V-notch impact tests, longitudinal direction, for pipes having thickness ≥ 11 mm and, when impact properties are required at -20°C, for thickness ≥ 6 mm

b) welded pipes:

- one tensile test on base metal, longitudinal direction
- one tensile test transverse to the weld for pipes with D ≥ 300 mm
- two flattening tests or two bend tests
- 3 Charpy V-notch impact tests, longitudinal direction, for pipes having thickness ≥ 11 mm and, when impact properties are required at -20°C, for thickness ≥ 6 mm.

**1.7 Non-destructive examination**

**1.7.1** Pipes are to be examined as specified in Sec 1, [5].

## Section 3 Pipes for Structural Applications

### 1 Requirements

#### 1.1 Scope

**1.1.1** Steel pipes for structural application at ambient temperature are to comply with the requirements specified in Sec 2, with the exception of the hydrostatic test which is not required.

#### 1.2 Steel grades

**1.2.1** Unless otherwise agreed with the Society, steel grades are to correspond to the types specified in Sec 2 with designation 410 HB-HD, 460 HB-HD and 510 HB-HD.

Steels for offshore structural applications are to be killed and fine grain treated.

The symbol ST is to be added to the steel designation to clearly indicate that pipes are intended for structural application.

#### 1.3 Mechanical and technological tests

**1.3.1** Pipes are to be tested as specified in Sec 2, [1.6] except pipes for offshore structural applications which are to be tested as specified in the following.

One pipe is to be selected from each batch for the required tests as follows:

a) seamless pipes:

- one tensile test, longitudinal direction
- Charpy V-notch impact tests on a set of specimens, longitudinal direction

b) welded pipes:

- one tensile test on base metal, longitudinal direction
- one tensile test transverse to the weld for pipes with  $D \geq 300$  mm
- face and root bend tests
- series of 3 Charpy V-notch tests on sets of 3 specimens taken transverse to the weld and located with the notch in the weld axis, the fusion line and 2 mm away from the fusion line in the HAZ
- hardness tests on the weld macrosection. The Vickers method HV10 is normally used. Three rows of indentations are to be made; one row at 2 mm below outer surface, one row at 2 mm below inner surface and one row crossing the weld root as shown in Fig 1. The values are not to exceed the maximum value allowed for the qualification of welding procedure (see Ch 12, Sec 3, [2.3.6]).

**Figure 1 : Hardness test HV10**

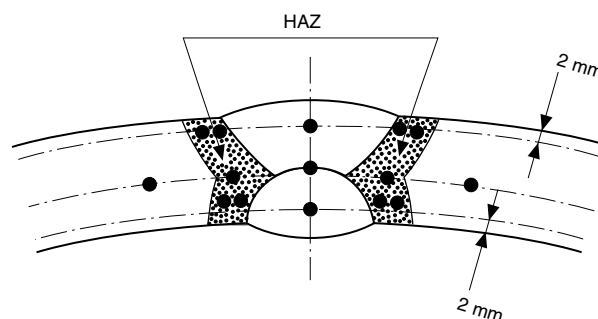

#### 1.4 Non-destructive examination

**1.4.1** Pipes are to be examined as specified in Sec 1, [5].

In addition, pipes for offshore structural applications are to be examined as shown in Tab 1.

**Table 1 : NDE of pipes for offshore structural applications**

Type of tests	Wall thickness (mm)			
	t ≤ 10 mm	10 mm < t ≤ 20 mm	20 < t ≤ 49 mm	t > 49 mm
UT of each weld	–	100% length	100% length	100% length
UT of pipe body (1)	–	grid (3)	grid (3)	10% surface (2)
RT of each weld	ends	ends	ends	ends
MPi of each weld	10% length (2)	10% length (2)	100% length	100% length
MPi of pipe body (1) (4)	grid (3)	grid (3)	grid (3)	10% surface
Repairs	100% MPi + radiographic inspection	100% MPi + UT	100% MPi + UT	100% MPi + UT

**Note 1:** UT = Ultrasonic testing; MPi = Magnetic particle inspection; RT = Radiographic testing.

- (1) Except if plates were US tested at the steel mill.
- (2) When non-destructive tests are carried out only at random (10%), UT and MPi are to be performed in different locations.
- (3) Dimensions of the grid to be agreed with the Society.
- (4) Seamless pipes and hot formed welded pipes only.

# Section 4                      Extra High Strength Steel Pipes for Welded Structure

## 1 Requirements

### 1.1 Scope

1.1.1 The requirements of this Section apply to seamless pipes intended for use in marine and offshore structural applications.

### 1.2 Steel grades

1.2.1 Unless otherwise agreed with the Society, steel grades are to correspond to the types specified for seamless tubulars in the Ch 3, Sec 5.

Seamless pipes are to meet the requirements of Ch 3, Sec 5, specified for tubular products with respect of manufacture, chemical composition and mechanical properties.

### 1.3 Condition of supply

1.3.1 The products are to be supplied in Normalised (N), Normalised Rolled (NR) or Quenched and Tempered (QT) condition as specified in Ch 3, Sec 5.

### 1.4 Mechanical properties

1.4.1 Pipes are to be tested as specified in Ch 3, Sec 5.

In addition, for pipes for offshore structural applications, one flattening or one bend test is to be carried out on pipe selected for each batch.

### 1.5 Non-destructive examination

1.5.1 Pipes are to be examined as specified in Sec 1, [5].

In addition, pipes for offshore structural applications are to be examined as shown in Sec 3, Tab 1.

# Section 5 Pipes for High Temperature Service

## 1 Requirements

### 1.1 Scope

1.1.1 The requirements of this Section apply to seamless and welded pipes intended for boilers, superheaters and heat exchangers, or pressure parts operating at elevated temperatures.

### 1.2 Steel grades

1.2.1 The requirements apply to carbon, carbon-manganese steels and low alloy steels (Mo, Cr-Mo and Cr-Mo-V).

1.2.2 Carbon and carbon manganese steels are classed into five groups which are indicated by the minimum ultimate tensile strength  $R_m$  (N/mm<sup>2</sup>): 320, 360, 410, 460 and 510.

1.2.3 Low alloy steels are designated according to the chemical composition into the grades 0,3Mo - 0,5Mo0,5Cr, 1Cr0,5Mo - 2,25Cr1Mo - 0,5Cr0,5Mo0,25V.

The figures mean the nominal percentage content of the main alloying elements.

### 1.3 Condition of supply

1.3.1 The products are to be supplied in the conditions indicated in Tab 2.

### 1.4 Chemical composition

1.4.1 The chemical composition on ladle analysis is to comply with the requirements specified in Tab 1. Steels are to be killed with the exception of grades 320 and 360 which may be semi-killed.

### 1.5 Mechanical properties

1.5.1 The mechanical properties and conditions of supply are specified in Tab 2.

### 1.6 Mechanical properties at elevated temperatures

1.6.1 The values of the yield stress  $R_{eH}$  or 0,2% proof stress  $R_{p0,2}$  at temperatures of 100°C and higher are given in Tab 3.

The values are for design purposes only. Their verification is in general not required during the testing, unless figures higher than those shown in Tab 3 and in accordance with recognised standards are proposed by the steel Manufacturer.

In such cases, the verification is required and the procedures detailed in [1.6.2] and [1.6.3] are to be followed.

**Table 1 : Chemical composition**

Steel grade	Chemical composition (%) (1)								
	C max	Mn	Si	P max	S max	Cr	Mo	V	Al tot
320	0,16	0,40-0,70	≤ 0,35	0,030	0,030				
360	0,17	0,40-1,00	≤ 0,35	0,030	0,030				
410	0,21	0,40-1,20	≤ 0,35	0,030	0,030				
460	0,22	0,80-1,40	≤ 0,35	0,030	0,030				
510	0,22	0,60-1,80	≤ 0,35	0,035	0,035				
0,3Mo	0,12-0,20	0,40-0,80	0,10-0,35	0,035	0,035		0,25-0,35		≤ 0,020
0,5Cr 0,5Mo	0,10-0,18	0,50-0,90	0,10-0,35	0,035	0,035	0,40-0,65	0,45-0,60		≤ 0,020
1Cr 0,5Mo	0,10-0,18	0,40-0,70	0,10-0,35	0,035	0,035	0,70-1,10	0,45-0,65		≤ 0,020
2,25Cr 1Mo	0,08-0,15	0,40-0,70	0,10-0,35	0,035	0,035	2,00-2,50	0,90-1,20		≤ 0,020
0,5Cr 0,5Mo 0,25V	0,10-0,18	0,40-0,70	0,15-0,50	0,035	0,035	0,70-1,10	0,45-0,65	0,22-0,28	≤ 0,020

(1) With the exception of refining elements, additional alloying elements are to be submitted for consideration and approval. Residual elements are permitted provided they do not impair the properties, subsequent processing or behaviour in service. For C and C-Mn steels, the following limits (%) apply: Ni ≤ 0,30; Cu ≤ 0,25; C ≤ 0,25; Mo ≤ 0,10; Total: Ni+Cu+Cr+Mo ≤ 0,70. For Mo and Cr-Mo alloy steels, the limits are the following (%): Ni ≤ 0,30; Cu ≤ 0,25.

**Table 2 : Mechanical properties - Conditions of supply**

Steel grade	Heat treatment (1)	Yield stress $R_{eH}$ (N/mm <sup>2</sup> ) min for t (mm)		Tensile strength $R_m$ (N/mm <sup>2</sup> )	Elong. $A_5$ (%) min.	Technological tests			
		t ≤ 40	40 < t ≤ 60			C (3)	Di/D (4)		
							≤ 0,6	0,6 < Di/D ≤ 0,8	> 0,8
320	N or NR	195		320 - 440	25	0,09	12	15	19
360	N or NR	225	215	360 - 500	25	0,09	12	15	19
410	N or NR	245	235	410 - 550	22	0,06	10	12	17
460	N or NR	270	260	460 - 580	21	0,06	8	10	15
510	N or NR	345	(2)	510 - 640	21	0,06	8	10	15
0,3Mo	N	270	260	450 - 600	22	0,07	8	10	15
0,5Cr 0,5Mo	N+T	270	260	440 - 570	22	0,07	8	10	15
1Cr 0,5Mo	N or N+T	290	280	440 - 590	22	0,07	8	10	15
2,25Cr 1Mo	N+T	280	270	450 - 600	20	0,06	8	10	15
	A	205	205	410 - 560	22	0,06	8	10	15
0,5Cr 0,5Mo 0,25V	N+T	300	290	460 - 610	20	0,06	8	10	15

(1) N = Normalising; NR = Normalising forming; T = Tempering; A = Annealing.

(2) To be agreed between Manufacturer and purchaser.

(3) Constant C for flattening test.

(4) Expanding or flanging test; increase of outside diameter D, in %, as a function of Di/D.

**Table 3 : Minimum proof stress ( $R_{p0,2}$ ) values at elevated temperatures**

Steel grade	$R_{p0,2}$ (N/mm <sup>2</sup> ) at a temperature (°C) of (1)									
	100	150	200	250	300	350	400	450	500	550
320 HA	170	160	150	125	100	95	90	85		
360 HA	190	175	165	145	120	115	110	105		
410 HA	210	200	190	170	150	140	130	125		
460 HA	235	220	215	195	180	165	160	155		
510 HA	250	240	230	215	195	180	175	170		
0,3Mo	240	235	225	205	175	160	155	150	145	
0,5Cr 0,5Mo (2)										
1Cr 0,5Mo	265	250	245	235	190	180	175	165	155	150
2,25Cr 1Mo (3)	260	250	245	235	230	215	205	195	180	165
2,25Cr 1Mo (4)	110	100	90	85	80	75	70	65	65	70
0,5Cr 0,5Mo 0,25V	260	250	235	215	190	185	175	165	155	145

(1) The values for temperatures < 200°C are given for information.

(2) Values to be determined during preliminary approval.

(3) Normalised and tempered condition.

(4) Annealed condition.

**1.6.2** When the  $R_{p0,2}$  is required to be verified, at least one tensile test for each cast is to be carried out at the agreed temperature.

In cases of pipes of different thickness, the sample is to be taken from a pipe selected among those of greatest thickness.

The dimensions of the specimens and the testing procedure are to be in accordance with the requirements of Ch 2, Sec 2, [1.1.8] and Ch 2, Sec 2, [1.2.5] respectively.

The results of tests are to comply with the values specified in Tab 3.

**1.6.3** As an alternative to the systematic verification of the required  $R_{p0,2}$  as in [1.6.2], it may be agreed with the individual steelmakers to carry out an adequate program of tests on the normal production of each steel, in accordance with an ad hoc procedure.

Subsequent to the satisfactory results of the approval tests, tensile tests at elevated temperatures are not generally required during the routine testing of the material supplied but as a random check for the confirmation.

**1.6.4** For design purposes only, the estimated values of the stress to rupture in 100000 hours are given in Tab 4 for groups of steels.

**Table 4 : Average values for stress to rupture in 100000 hours (N/mm<sup>2</sup>)**

Temperature (°C)	Carbon and carbon manganese steels		Alloy steels				
	360 / 410	460 / 510	0,3Mo	1Cr 0,5Mo	2,25Cr 1Mo		0,5Cr 0,5Mo 0,25V
					N + T (1) (3)	A (2)	
380	170	225					
390	155	200					
400	140	175					
410	125	155					
420	110	135					
430	100	115					
440	90	100					
450	75	85	240	280	220	195	
460	65	70	205	250	205	180	
470	55	60	175	220	185	165	
480	45	55	140	200	170	155	215
490	35	45	115	170	150	140	190
500		40	95	140	135	125	170
510			75	120	120	115	150
520			60	97	105	100	130
530			45	80	90	90	115
540			35	65	76	76	100
550			30	54	68	68	85
560				43	58	58	70
570				35	50	50	55
580					44	44	45

**Note 1:** The values shown are estimated average values; the lower limit of the range is approximately 20% less than the average value.  
**(1)** N + T = Normalising and Tempering.  
**(2)** A = Annealing.  
**(3)** When the tempering temperature exceeds 750°C, the values relevant to the annealing heat treatment are to be used.

**1.7 Mechanical and technological tests**

**1.7.1** For pipes intended for boiler headers, the tests are to be carried out on each as made length.

Other pipes are to be presented in batches and the number is defined in Sec 1, Tab 1.

Two pipes are to be selected from each batch for the required tests, as follows:

- a) seamless pipes and tubes:
  - one tensile test, longitudinal direction
  - one flattening test or one bend test on a mandrel of diameter 4 t
  - one expanding or flanging test, when required
- b) welded pipes:
  - one tensile test on base metal, longitudinal direction
  - one tensile test transverse to the weld for pipes with D ≥ 300 mm
  - two flattening or two bend tests transverse to the weld for pipes with D ≥ 300 mm on a mandrel of diameter 4 t
  - one expanding or flanging test, when required.

When required in [1.6.1], a tensile test at elevated temperature is to be performed on one sample per cast.

**1.8 Non-destructive examination**

**1.8.1** Pipes are to be examined as specified in Sec 1, [5].



# Section 6 Ferritic Steel Pipes for Pressure Service at Low Temperature

## 1 Requirements

### 1.1 Scope

**1.1.1** The requirements of this Section apply to seamless and welded steel pipes intended for construction of piping systems, pressure vessels and plants, when impact properties at temperatures lower than  $-20^{\circ}\text{C}$  are specified.

Provision is made for pipes with wall thickness up to 40 mm.

### 1.2 Steel grades

**1.2.1** The requirements apply to carbon and carbon-manganese steels and nickel steels.

**1.2.2** The carbon and carbon-manganese steels are classed into four groups which are indicated by the minimum ultimate tensile strength  $R_m$  (N/mm<sup>2</sup>): 360, 410, 460 and 510.

Each group is further subdivided into two grades LE and LF, based on the quality level and impact properties.

The letters LE and LF mean impact properties at  $-40^{\circ}\text{C}$  and  $-60^{\circ}\text{C}$ , respectively.

**1.2.3** The Ni steels are designated according to the chemical composition into the grades 2,25Ni, 3,5Ni and 9,0Ni. The figures mean the Ni nominal percentage content.

### 1.3 Condition of supply

**1.3.1** The pipes are to be supplied in the conditions indicated in Tab 3 and Tab 4.

### 1.4 Chemical composition

**1.4.1** The steel is to be killed and fine grained and the chemical composition on ladle analysis is to comply with the requirements specified in Tab 1 and Tab 2.

**Table 1 : Carbon and carbon manganese steels - Chemical composition**

Steel grade	Chemical composition (%) (1)							
	C max	Mn	Si	P max	S max	Ni	Al tot	Others (3)
360 LE-LF	0,17	0,40 - 1,00	$\leq 0,35$	0,030	0,025	$\leq 0,30$ (2)	$\geq 0,020$	Cr $\leq 0,25$ Cu $\leq 0,30$ Mo $\leq 0,10$
410 LE-LF	0,18	0,60 - 1,30	$\leq 0,35$	0,030	0,025	$\leq 0,30$ (2)	$\geq 0,020$	
460 LE-LF	0,18	0,60 - 1,30	$\leq 0,35$	0,030	0,025	$\leq 0,30$ (2)	$\geq 0,020$	
510 LE-LF	0,20	1,00 - 1,60	$\leq 0,35$	0,030	0,025	$\leq 0,30$ (2)	$\geq 0,020$	

(1) With the exception of refining elements, additional alloying elements are to be submitted for consideration and approval; residual elements are permitted provided they do not impair the properties, subsequent processing or behaviour in service.  
(2) Higher Ni content up to 0,80% may be agreed for LF grades.  
(3) When the pipes are subjected to hot forming: Cu  $< 0,25$ .

**Table 2 : Nickel steels - Chemical composition**

Steel grade	Chemical composition (%) (1)						
	C max	Mn	Si	P max	S max	Ni	Others (2)
2,25 Ni	0,17	0,30 - 0,90	0,15 - 0,35	0,025	0,020	2,10 - 2,50	Cr $\leq 0,25$ Cu $\leq 0,30$ Mo $\leq 0,10$
3,5 Ni	0,15	0,30 - 0,90	0,15 - 0,35	0,025	0,020	3,25 - 3,75	
9,0 Ni	0,12	0,30 - 0,90	0,15 - 0,35	0,025	0,020	8,50 - 9,50	

(1) With the exception of refining elements, additional alloying elements are to be submitted for consideration and approval; residual elements are permitted provided they do not impair the properties, subsequent processing or behaviour in service.  
(2) When the pipes are subjected to hot forming: Cu  $< 0,25$ .

**1.5 Mechanical properties**

1.5.1 The mechanical properties and conditions of supply are specified in Tab 3 and Tab 4.

**1.6 Mechanical and technological tests**

1.6.1 The pipes are to be presented in batches as per Sec 1, [9.1.1] and the number of pipes per batch is defined in Sec 1, Tab 1. Two pipes are to be selected from each batch for the required tests, as follows:

a) seamless pipes and tubes:

- one tensile test, longitudinal direction
- one flattening test or one bend test
- 3 Charpy V-notch impact tests, longitudinal direction, for thickness  $\geq 6$  mm

b) welded pipes:

- one tensile test on base metal, longitudinal direction
- one tensile test transverse to the weld for pipes with  $D \geq 300$  mm
- two flattening tests or two bend tests transverse to the weld for pipes with  $D \geq 300$  mm
- 3 Charpy V-notch impact tests, longitudinal direction, for thickness  $\geq 6$  mm.

**1.7 Non-destructive examination**

1.7.1 Pipes are to be examined as specified in Sec 1, [5].

**Table 3 : Carbon and carbon manganese steels - Mechanical properties and condition of supply**

Steel grade	Heat treatment (1)	Yield stress $R_{eH}$ (N/mm <sup>2</sup> ) min. for t (mm)		Tensile strength $R_m$ (N/mm <sup>2</sup> )	Elong. $A_5$ (%) min.	Average impact energy (J) min.		Technological tests		
		$\leq 25$	$25 < t \leq 40$			Test temp (°C)	KVL	Flattening test constant C for t/D		Bend test diameter mandrel
								t/D $\leq 0,15$	t/D $> 0,15$	
360 LE	N	225	215	360-500	22	-40	27	0,09	0,08	4 t
360 LF						-60				
410 LE	N	255	245	410-550	20	-40	27	0,07	0,06	
410 LF						-60				
460 LE	N	275	265	460-580	20	-40	27			
460 LF						-60				
510 LE	N	345	335	510-630	19	-40	34			
510 LF						-60				

(1) N = Normalising

**Table 4 : Nickel steels - Mechanical properties and condition of supply**

Steel grade	Heat treatment (1)	Yield stress $R_{eH}$ (N/mm <sup>2</sup> ) min. for t (mm)		Tensile strength $R_m$ (N/mm <sup>2</sup> )	Elong. $A_5$ (%) min.	Average impact energy (J) min.		Technological tests		
		$\leq 25$	$25 < t \leq 40$			Test temp (°C)	KVL	Flattening test constant C for t/D		Bend test diameter mandrel
								t/D $\leq 0,15$	t/D $> 0,15$	
2,25 Ni	N or N+T or Q+T	245	235	450-640	21	-70	34	0,07	0,06	4 t
3,5 Ni	N or N+T or Q+T	255	245	450-640	19	-95	34			
9,0 Ni	N+N+T	470	460	640-840	16	-196	41			
9,0 Ni	Q+T	570	560	690-840						

(1) N = Normalising; N+T = Normalising and Tempering; N+N+T = Double Normalising and Tempering; Q+T = Quenching and Tempering

# Section 7 Austenitic and Austenitic-Ferritic Stainless Steel Pipes

## 1 Requirements

### 1.1 Scope

**1.1.1** The requirements of this Section apply to seamless and welded austenitic and austenitic-ferritic stainless steel pipes intended for use in the construction of piping systems for chemicals, liquefied gases and bulk chemical tankers.

**1.1.2** Austenitic stainless steels are suitable for use at both elevated and low temperatures.

When austenitic stainless steels are proposed for use at elevated temperatures, details of chemical composition, heat treatment and mechanical properties are to be submitted for consideration and approval.

Ferritic-austenitic (duplex) steels are suitable for use for design temperatures between  $-20^{\circ}\text{C}$  and  $+275^{\circ}\text{C}$ .

### 1.2 Steel grades

**1.2.1** The requirements apply to Cr-Ni stainless steels.

Steels are designated according to AISI grades; the corresponding ISO grades are also indicated in Tab 1.

**Table 1 : Chemical composition**

ISO grade designation	AISI grade designation	Chemical composition (%) (1)								
		C max	Mn max	Si max	P max	S max	Cr	Ni	Mo	Others
X2CrNi1810	304L	0,03	2,00	1,00	0,045	0,035	17,0-19,0	9,0-13,0	–	
X5 CrNi1810	304	0,07	2,00	1,00	0,045	0,035	17,0-19,0	9,0-13,0	–	
X2CrNiMo1713	316L	0,03	2,00	1,00	0,045	0,035	16,0-18,5	10,0-14,0	2,0-2,5	
X5CrNiMo1713	316	0,07	2,00	1,00	0,045	0,035	16,0-18,5	10,0-14,0	2,0-2,5	
X6CrNiTi1810	321	0,08	2,00	1,00	0,045	0,035	17,0-19,0	9,0-13,0	–	$5x\text{C} \leq \text{Ti} \leq 0,80$
X6CrNiNb1810	347	0,08	2,00	1,00	0,045	0,035	17,0-19,0	9,0-13,0	–	$10x\text{C} \leq \text{Nb} \leq 1,0$
X2CrNiMoN2253	UNS31803	0,03	2,00	1,00	0,030	0,020	21,0-23,0	4,50-6,50	2,5-3,5	$0,08 \leq \text{N} \leq 0,20$

(1) With the exception of refining elements, additional alloying elements are to be submitted for consideration and approval. Residual elements are permitted provided they do not impair the properties, subsequent processing or behaviour in service of the material.

**Table 2 : Mechanical properties**

Steel grade	Yield strength (N/mm <sup>2</sup> ) min. (1)		Tensile strength R <sub>m</sub> (N/mm <sup>2</sup> )	Elong. A <sub>5</sub> (%) min	Average impact energy KVL (J) at		C (2)	Technological tests		
	R <sub>p0,2</sub>	R <sub>p1</sub>			–196°C	–20°C		Di/D (3)		
								≤ 0,6	0,6 < Di/D ≤ 0,8	> 0,8
304L	175	205	490 - 690	30	41			9	15	17
304	195	235	490 - 690	30	41					
316L	185	215	490 - 690	30	41					
316	205	245	490 - 690	30	41	0,09				
321	195	235	510 - 710	30	41					
347	205	245	510 - 710		41					
UNS 31803	450		620	25		27				

(1) Conventional proof stress; the 0,2% proof stress values are given for information and, unless otherwise agreed, are not required to be verified during the test.  
(2) Constant C for flattening test.  
(3) Expanding or flanging test; increase of outside diameter D, in %, as a function of Di/D.

### 1.3 Condition of supply

1.3.1 The pipes are to be supplied in the solution treated condition.

### 1.4 Chemical composition

1.4.1 The chemical composition on ladle analysis is to comply with the requirements specified in Tab 1.

### 1.5 Mechanical properties

1.5.1 The mechanical properties are specified in Tab 2.

### 1.6 Mechanical and technological tests

1.6.1 Unless they are required to be tested on each length, pipes are to be presented in batches, as specified in Sec 1, Tab 1. Two pipes are to be selected from each batch for the required tests, as follows:

a) seamless pipes:

- one tensile test, longitudinal direction
- one flattening test or one bend test with mandrel diameter of 3 t
- 3 Charpy V-notch impact tests, longitudinal direction
- one expansion or flanging test, when required

b) welded pipes:

- one tensile test on base metal, longitudinal direction
- one tensile test transverse to the weld for pipes with  $D \geq 300$  mm
- two flattening or two bend tests transverse to the weld with mandrel diameter of 3 t
- 3 Charpy V-notch impact tests, longitudinal direction, when required
- one expansion or flanging test when required.

When required, one tensile test at elevated temperature is to be performed on one sample per cast.

Unless otherwise specified for individual cases, the impact test of austenitic stainless steel is required only for design temperature less than  $-105^{\circ}\text{C}$  and are to be carried out at  $-196^{\circ}\text{C}$ .

### 1.7 Non-destructive examination

1.7.1 Pipes are to be examined as specified in Sec 1, [5].

### 1.8 Corrosion tests

1.8.1 For materials used for piping systems for chemicals, the corrosion tests, ASTM A262 Practice E or ASTM A262 Practice C (Nitric acid test), as appropriate, may be required to be carried out on two pipes per batch.

Tests in accordance with other recognised standards are accepted, subject to the agreement of the Society.

# Section 8 Fittings

## 1 Requirements

### 1.1 Scope

**1.1.1** The requirements of this Section apply to seamless and welded carbon, carbon manganese, low alloy and alloy steel fittings, fabricated from pipes or plates and intended for piping systems or pressure plants.

### 1.2 Steel grades

**1.2.1** Fittings fabricated from pipes are to meet the requirements of Sec 1 to Sec 7, depending on the applications, with respect to manufacture, chemical composition and mechanical properties. Fittings may be hot or cold formed from sections of pipes.

Fittings fabricated from plates are to meet the requirements of the Articles from Ch 3, Sec 1 to Ch 3, Sec 9, depending on the applications, with respect to manufacture, chemical composition and mechanical properties.

Fittings may be made from sections of plates formed in one or more shells and welded together. The relevant welding process is to be approved.

**1.2.2** Unless otherwise required, the material used for the fabrication of the fittings is to be covered by a works' certificate (W).

### 1.3 Condition of supply

**1.3.1** All fittings are to be in the heat treated or hot working condition specified in the various Sections for the corresponding material.

Fittings in ferritic steel manufactured by hot forming may be delivered in the normalised forming condition in lieu of normalising, provided that evidence is given of the equivalence of such condition; see Sec 1, [7.1.1].

Fittings manufactured by cold forming are in general to be submitted to heat treatment after forming.

A proposal to deliver fittings in the cold formed condition may be considered by the Society; to this end, the Manufacturer is to submit detailed information relevant to forming procedure, mechanical properties after forming and destination of the products.

The heat treatment procedure of welded fittings is to be defined during the approval tests.

### 1.4 Mechanical properties

**1.4.1** The mechanical properties of the finished fittings are to comply with the values specified for the starting materials (plate or pipe).

### 1.5 Mechanical and technological tests

**1.5.1** The fittings are to be presented for testing in batches homogeneous for cast and in the number indicated in Sec 1, Tab 1.

A Brinell hardness test HB is to be performed on 10% of the fittings, with a minimum of 3 units, to verify the homogeneity of the batch. The difference in the hardness value may not be greater than 30 units.

Two fittings per batch are to be selected for the mechanical and technological tests specified in Sec 2 to Sec 7 depending on the application.

The tensile tests are to be performed on the hardest and softest fittings.

### 1.6 Non-destructive examination

**1.6.1** Unless otherwise specified during the approval procedure or in the order, checks with radiographic examination are to be performed on welds randomly selected. These are to be selected in such a way that every size of fittings is included.

### 1.7 Marking and certification

**1.7.1** The requirements specified in Sec 1 relevant to marking in Sec 1, [10] and certification in Sec 1, [11] are to be complied with, as appropriate.

## CHAPTER 5 STEEL FORGINGS

---

Section 1	General Requirements
Section 2	Forgings for Hull, Offshore Structures and Welded Components in General
Section 3	Forgings for Machinery, Shafts and Non-Welded Components in General
Section 4	Forgings for Crankshafts
Section 5	Forgings for Gearing
Section 6	Forgings for Turbines
Section 7	Forgings for Boilers, Pressure Vessels and Systems
Section 8	Ferritic Steel Forgings for Low Temperature Service
Section 9	Stainless Steel Forgings

# Section 1 General Requirements

## 1 Scope

### 1.1 General

**1.1.1** The requirements of this Chapter apply to steel forgings intended for hull, structural applications, offshore construction, machinery, boilers, pressure vessels and piping systems.

These requirements may also be applied to the testing of semi-finished products, to be further processed by forging, and to rolled products, when these are acceptable in lieu of forged material. See Ch 3, Sec 8.

This Section specifies the requirements common to all the above-mentioned steel products, while the appropriate specific requirements are indicated in Sec 2 to Sec 9.

#### 1.1.2 Mass productions

For mass produced small forgings, the Manufacturer may adopt modified procedures for testing and inspection subject to the approval of the Society.

#### 1.1.3 Other specifications

Forgings complying with international, national or proprietary specifications may be accepted by the Society, provided such specifications give reasonable equivalence to the requirements of these Rules and other relevant Society's Rules or are approved for a specific application.

Such products, when accepted, are designated by their standard identification or as agreed at the time of the approval.

Unless otherwise agreed, survey and certification of steel forgings complying with other specifications are to be carried out in accordance with the requirements of these Rules and other relevant Society's Rules.

#### 1.1.4 Special requirements

Special requirements may be specified in the case of applications intended for dangerous substances or for particularly severe service conditions.

In the case of applications involving the storage and transport of liquefied gases or fluids at low temperature, reference is to be made to the Society's Rules for the Classification of Steel Ships, NR467, Part D, Chapter 9, and, to the International Code for the Construction and Equipment of Ships Carrying Liquefied Gases in Bulk (IGC Code).

For gas fuelled ships, reference is to be made to Society Rule Note NR529, and, to the International Code of Safety for Ships using Gases or other Low-flash point Fuels (IGF Code).

## 2 Manufacturing

### 2.1 Manufacturing process

**2.1.1** The steel is to be manufactured as detailed in Ch 3, Sec 1, [2].

Adequate top and bottom discards are to be made to ensure freedom from piping and harmful segregations in the finished forgings.

Hot forging, to be carried out within the temperature range specified, is to be gradual and uniform and extended, as far as possible, to the final dimensions of the piece.

The plastic deformation is to be such as to ensure soundness, uniformity of structure and satisfactory mechanical properties after heat treatment.

At an appropriate stage of manufacture, after completion of all hot working operations, forgings are to be suitably heat treated to refine the grain structure and to obtain the required mechanical properties.

#### 2.1.2 Reduction ratio

The reduction ratio is to be calculated with reference to the average cross-sectional area of the cast material. Where the cast material is initially upset, this reference area may be taken as the average cross-sectional area after this operation. Unless otherwise approved the total reduction ratio is to be at least as specified in Tab 1.

#### 2.1.3 Flame and arc-air shaping

The shaping of forgings or rolled slabs and billets by flame cutting, scarfing or arc-air gouging is to be undertaken in accordance with recognised good practice and, unless otherwise approved, is to be carried out before the final heat treatment. Preheating is to be employed when necessitated by the composition and/or thickness of the steel. For certain components, subsequent machining of all flame cut surfaces may be required.

**Table 1 : Reduction Ratio**

Raw material	Finished product	Total Reduction Ratio	
Ingot, forged bloom or billet	Forging	3:1 where L>D (1)	1,5:1 where L≤ D (1)
Rolled product	Forging	4:1 where L>D (1)	2:1 where L≤ D (1)
Ingot, forged bloom, billet or rolled product without initial forging reduction ratio	Forging made by upsetting	$L_0/3 \geq L_1$ (2)	
Ingot, forged bloom, billet or rolled product with initial forging reduction ratio of at least 1.5:1	Forging made by upsetting	$L_0/2 \geq L_1$ (2)	
(1) L and D are the length and diameter respectively of the part of the forging under consideration			
(2) $L_0$ is the length before upsetting and $L_1$ is the length after upsetting			

### 2.1.4 Welding of forgings

When two or more forgings are joined by welding to form a composite component, the proposed welding procedure specification is to be submitted for approval.

Welding of steel forgings intended for steel ship hull and welded structure is to be approved in accordance with Ch 12, Sec 3. Welding procedure qualification for others ship applications is to be approved in accordance with Ch 12, Sec 4.

Welders intended to be engaged in fusion welding of steel forgings for hull structures are to be qualified in accordance with NR476.

## 3 Approval

### 3.1 Steelmaking

3.1.1 The works at which the steel was produced is to be approved as per Ch3, Sec1, [3.1] for semi-finished products. Where steel is produced at a separate works of the forging, the steel manufacturer is also to be approved.

### 3.2 Forging process

3.2.1 Manufacturers of steel forgings are to be recognised by the Society in accordance with NR320.

3.2.2 When required in the relevant Sections, provisions for approval of manufacturing process are given in NR480.

## 4 Quality of materials

### 4.1 General requirements

4.1.1 All forgings are to be free from surface or internal defects which would be detrimental to their proper application in service.

## 5 Chemical composition

### 5.1 General requirements

5.1.1 All forgings are to be made from killed steel and the chemical composition is to be appropriate for the type of steel, dimensions and required mechanical properties of the forgings being manufactured.

The chemical composition of each heat is to be determined by the Manufacturer on a sample taken preferably during the pouring of the heat. When multiple heats are tapped into a common ladle, the ladle analysis shall apply.

The chemical composition is to comply with the overall limits given in the relevant Sections of this Chapter or, where applicable, the requirements of the approved specification.

At the option of the Manufacturer, suitable grain refining elements such as aluminium, niobium or vanadium may be added. The content of such elements is to be reported.

Elements designated as residual elements in the individual specifications are not to be intentionally added to the steel. The content of such elements is to be reported.

5.1.2 Carbon equivalent ( $C_{EQ}$ ) values, when used in this Chapter, are calculated using the following formula:

$$C_{EQ} = C + \frac{Mn}{6} + \frac{Cr + Mo + V}{5} + \frac{Ni + Cu}{15} \quad \%$$



## 6 Heat treatment (including surface hardening and straightening)

### 6.1 General requirements

- 6.1.1** At an appropriate stage of manufacture, after completion of all hot working operations, forgings are to be suitably heat treated to refine the grain structure and to obtain the required mechanical properties.
- 6.1.2** The delivery condition is to meet the design and application requirements. It is the manufacturer's responsibility to select the appropriate heat treatment method to obtain the required mechanical properties.
- 6.1.3** Heat treatment is to be carried out in suitable furnaces as detailed in Ch1, Sec1, [2.3.1].
- 6.1.4** If, for any reason, a forging is subsequently heated for further hot working, the forging is to be reheat treated.
- 6.1.5** The acceptable heat treatment conditions are indicated in the Sections relevant to the various forged products. When more than one heat treatment condition is specified, the choice of the supply condition, unless otherwise required, is left to the Manufacturer; the condition of supply is always to be mentioned in the testing documentation.
- 6.1.6** When the heat treatment is quenching and tempering and the piece cannot be forged near the final dimensions and shape, it is to be worked by rough machining or flame cutting prior to being quenched and tempered.
- 6.1.7** If a forging is locally reheated or any straightening operation is performed after the final heat treatment, consideration is to be given to a subsequent stress relieving heat treatment. The manufacturer shall have strict control of this temperature in order to avoid any detrimental effects to the final heat treatment and resultant microstructure and mechanical properties of the forging.
- 6.1.8** Where it is intended to surface harden forgings, full details of the proposed procedure and specification are to be submitted for the approval of the Society. For the purposes of this approval, the Manufacturer may be required to demonstrate by test that the proposed procedure gives a uniform surface layer of the required hardness and depth and that it does not impair the soundness and properties of the steel.
- 6.1.9** Where induction hardening or nitriding is to be carried out, forgings are to be heat treated at an appropriate stage to a condition suitable for this subsequent surface hardening.
- 6.1.10** Where carburising is to be carried out, forgings are to be heat treated at an appropriate stage (generally either by full annealing or by normalizing and tempering) to a condition suitable for subsequent machining and carburising.
- 6.1.11** The forge is to maintain records of heat treatment identifying the furnace used, furnace charge, date, temperature and time at temperature. The records are to be presented to the surveyor and copies provided on request.

## 7 Mechanical tests

### 7.1 General

**7.1.1** The requirements relevant to the type and number of tests to be carried out are given in the Sections relevant to the various products.

Test material, sufficient for the required tests and for possible retest purposes, is to be provided with a cross-sectional area of not less than that part of the forging which it represents.

Except for components which are to be carburised or for hollow forgings where the ends are to be subsequently closed, test material is not to be cut from a forging until all heat treatment has been completed.

For forgings to be carburised after machining, sufficient test material is to be provided both for preliminary tests after forging and for final tests after completion of carburising Sec 5, [1.7.1].

For forgings to be hot worked and/or heat treated by the purchaser, the samples to be tested at the Manufacturer's works are to be forged and heat treated accordingly.

### 7.2 Individual testing

**7.2.1** For forgings in quenched and tempered condition having a mass of more than 500 kg, and, forgings in other delivery conditions having a mass of more than 1000 kg, individual testing is to be applied. The test material is to be integral with each forging and is to be taken from a suitable extension as specified in the various Sections and in accordance with Sec 4, Fig 1 to Sec 6, Fig 2.

Where one forging is subsequently divided into a number of components, all of which are heat treated together in the same furnace charge, for test purposes this may be regarded as one forging and the number of tests required is to be related to the total length and mass of the original multiple forging.

### 7.3 Batch testing

7.3.1 A batch testing procedure may be adopted in the following cases:

- a) Forgings in normalized or solution treated condition with mass up to 1000 kg each of similar shape and dimensions, made from the same heat, heat treated in the same furnace charge and with a total mass of the batch not exceeding 6 tonnes
- b) Forgings in quenched and tempered condition with mass up to 500 kg each of similar shape and dimensions, made from the same heat, heat treated in the same furnace charge and with a total mass of the batch not exceeding 3 tonnes

The test material may be cut from one or more forgings of the batch [7.5.1] or, alternatively, separately forged test material may be used. When separately forged, the test material is to have a reduction ratio similar to that used for the forgings represented. They are to be properly identified and heat treated together with the forgings of the batch.

When samples are integral with the forging, the requirements of [7.2.1] apply.

### 7.4 Batch testing for rolled products

7.4.1 When the use of rolled bars as a substitute for forging material is permitted, a batch testing procedure may be adopted and the batch composition is to be as follows:

- a) Bars made from the same rolled ingot or bloom provided that where this is cut into individual lengths, these are all heat treated in the same furnace charge, or:
- b) Bars of the same diameter made from the same heat, heat treated in the same furnace charge and with a total mass of the batch not exceeding 2,5 tonnes.

The test samples are taken from one or more pieces of the batch [7.5.1].

### 7.5 Sampling

7.5.1 In the case of individual testing [7.2.1], the number and position of samples necessary for the required tests are given in the **Articles** relevant to the various products.

In the case of batch testing [7.3.1], one sample at least is to be taken from the forging representative of the batch; where the number of pieces in the batch exceeds 20, two samples are to be taken.

A set of test specimens is to consist of:

- a) one tensile test specimen
- b) three Charpy V-notch impact tests specimens when required in the Sections relevant to the various products.

### 7.6 Preparation of test specimen

7.6.1 Test specimens are normally to be cut from the samples with their axes either mainly parallel (longitudinal test) or mainly tangential (tangential test) to the principal axial direction of each product, as required in the Sections relevant to the various products.

The test specimens are to be positioned as follows:

- a) For forgings having a thickness,  $t$ , or diameter  $D$  up to maximum 50mm, the longitudinal axis of the test specimen is to be located at a distance of  $t/2$  or  $D/2$  below the heat treated surfaces.
- b) For forgings having a thickness,  $t$ , or diameter  $D$  greater than 50 mm, the longitudinal axis of the test specimen is to be located at a distance of  $t/4$  or  $D/4$  (mid-radius) or 80mm, whichever is less, below any heat treated surface. Test specimen is to be located with its longitudinal axis at a distance from any heat treated surface as shown in Fig 1.
- c) For ring and disc forgings (noting that the test specimen locations for these shaped forgings may be different to elongated or free form forgings), tangential sample is to be taken at  $t/2$  for thickness  $\leq 25$  mm and 12,5 mm below the surface for thickness  $> 25$  mm, in both the vertical and horizontal direction. Where achievable, for thickness  $> 25$  mm, no part of the test material shall be closer than 12,5 mm to any heat treated surface, as shown in Fig 1.

Figure 1 : Position of the test specimen

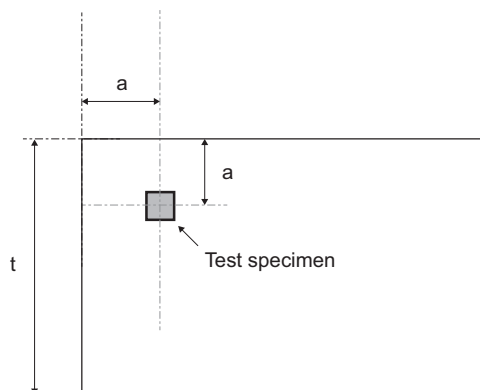

a : Distance from the test specimen to heat treated surface based on [7.6.1] b) or c).

**7.6.2** Where the manufacturer can demonstrate that a proposed testing location or orientation is more representative of the required mechanical properties of a component, this may be agreed with the Society. In such cases, the heat treatment process, a proposed testing location or orientation, and technical justification is to be submitted to the Society for approval.

## **7.7 Tensile test**

**7.7.1** Reference is made to the applicable requirements of Chapter 2.

The results of the tensile test at ambient temperature are to comply with the requirements in the appropriate Tables, or in the approved specification when steels other than those specified in these Rules are accepted.

Reference is made to Sec 7, [1.7] for the properties at elevated temperatures and their verification, when required.

## **7.8 Impact test**

**7.8.1** Reference is made to the applicable requirements of Chapter 2.

The average value of a set of 3 tests is to comply with the average value required in the appropriate Tables, or in the approved specification when steels other than those specified in these Rules are accepted.

Only one individual value may be lower than the average value required, provided that it is not less than 70% of it.

The minimum average values for impact tests indicated in the Tables are relevant to standard specimens 10 x 10 mm<sup>2</sup>.

## **7.9 Hardness test**

**7.9.1** At the discretion of the Society, hardness tests may be required on the following:

- a) quenched and tempered gear forgings after completion of heat treatment and prior to machining the gear teeth Sec 5, [1.6.2]
- b) surface-hardened gear forgings after the teeth have been ground to the finished profile Sec 5, [1.7.2]
- c) surface-hardened forgings in general
- d) batch tested forgings: at least one hardness test on each forging

The results of hardness tests in the cases a) and d) are to be reported.

The results of hardness tests in the cases b) and c) are to comply with the approved specification.

## **7.10 Re-test procedures**

**7.10.1** Samples for possible re-tests are to be taken as near as practicable to the specimens used for the original tests but alternatively may also be taken from another test position or sample representative of the forging or batch of forgings.

Reference is made to Ch 1, Sec 1, [3.5].

For tensile re-test procedure, reference is made to Ch 2, Sec 2, [1.3].

For Charpy V-notch re-test procedure, reference is made to Ch 2, Sec 4, [1.4].

**7.10.2** At the option of the manufacturer, when a forging or a batch of forgings has failed to meet the test requirements, it may be reheat treated and re-submitted for acceptance tests.

## **8 Pressure test**

### **8.1 General requirements**

**8.1.1** Forgings subjected to internal pressure are to be subjected to a hydraulic pressure test in compliance with the conditions laid down in the applicable parts of the Rules.

The test pressure is to be measured by means of a suitable calibrated pressure gauge.

The test is to be performed on the forging in the finished condition and before the application of any coating which may conceal the effect of the test.

Unless otherwise agreed, the test of forgings is to be carried out in the presence of the Surveyor.

A report confirming the satisfactory results of the pressure tests and indicating the relevant testing conditions is to be issued by the Manufacturer.

## **9 Visual and dimensional examination**

### **9.1 Visual examination**

**9.1.1** All forgings are to be subjected to a 100% visual examination of all accessible surfaces by the manufacturer and made available to the Surveyor. Where applicable, this visual examination is to include the examination of internal surfaces and bores.

## **9.2 Verification of dimensions**

**9.2.1** The verification of dimensions and tolerances is the responsibility of the Manufacturer.

Checks of dimensions for verification of compliance with the approved drawings are in general required for important forgings, to the Surveyor's satisfaction.

## **10 Non-destructive examination**

### **10.1 General requirements**

**10.1.1** When required by the relevant construction Rules, by the Society on the approved plans, by the approved procedure for welded composite components or, in particular cases, by the Surveyor, appropriate non-destructive testing is also to be carried out in accordance with a recognized standard.

Reference is made to the general provisions given in Ch 1, Sec 1, [3.6].

The method and the extent of inspection, NDT and acceptance criteria are to be agreed with the Society. IACS Recommendation No. 68 is regarded as an example of an acceptable standard.

For mass produced forgings the extent of examination is to be established at the discretion of the Society.

Unless otherwise agreed, examinations are to be carried out by the manufacturer, although Surveyors may request to be present in order to verify that the examination is being carried out in accordance with the agreed procedure.

The Manufacturer is to provide the Surveyor with a report confirming that the required examinations have been carried out without revealing significant defects, including reference of the testing standard and the agreed acceptance criteria.

### **10.2 Magnetic and liquid penetrant examination**

**10.2.1** Magnetic particle or liquid penetrant testing is to be carried out when the forgings are in the finished condition.

Where current flow methods are used for magnetisation, particular care is to be taken to avoid damaging machined surfaces by contact burns from the prods.

### **10.3 Ultrasonic examination**

**10.3.1** Ultrasonic examination is to be carried out following the final heat treatment and at a stage when the forgings have been machined to a condition suitable for this type of examination.

Both radial and axial scanning are to be carried out, when appropriate for the shape and dimensions of the forging being examined.

**10.3.2** If the forging is supplied in the 'as forged' condition for machining at a separate works, the manufacturer is to ensure that a suitable ultrasonic examination is carried out to verify the internal quality of the forging.

When advanced ultrasonic testing methods are applied reference is made to Chapter 14.

## **11 Rectification of defects**

### **11.1 Rectification of defects by grinding**

**11.1.1** Defects may be removed by grinding or chipping and grinding provided the component dimensions are acceptable.

The resulting grooves are to have a bottom radius of approximately three times the groove depth and are to be blended into the surrounding surface so as to avoid any sharp contours. Complete elimination of the defective material is to be verified by magnetic particle testing or liquid penetrant testing.

### **11.2 Rectification of defects by welding**

**11.2.1** Repair welding of forgings except those subjected to torsional fatigue, such as crankshaft forgings and propeller shaft forgings, may be permitted subject to prior approval of the Society.

In such cases, full details of the extent and location of the repair, the proposed welding procedure, heat treatment, if any, and subsequent inspection procedures, are to be submitted for the approval.

Records of repairs and subsequent inspections traceable to each forging repaired are to be prepared by the forging Manufacturer. The records are to be presented to the Surveyor on request.

## **12 Identification and marking**

### **12.1 General requirements**

**12.1.1** The Manufacturer is to adopt a system of identification which will enable all finished forgings to be traced to the original cast and their manufacturing.

Before acceptance, all forgings which have been tested with satisfactory results are to be marked with the following details:

- a) Manufacturer's name or trade mark
- b) Society's brand
- c) Identification mark for the grade of steel
- d) Cast number or other marking which will enable the history of the fabrication of the forging to be traced
- e) Additional, optional marks such as file number and code of local inspection office, Surveyor's personal brand
- f) Test pressure, where applicable
- g) Date of final inspection.

Modified arrangements for identification and marking of small forgings manufactured in large numbers may be agreed with the Society.

## 13 Documentation and certification

### 13.1 General requirements

**13.1.1** The testing documentation indicated in Ch 1, Sec 1, [4.2.1] is to be issued and is to include all the information, as appropriate.

Where applicable, the reports relevant to the non-destructive examination [10.1.1], weld repair [11.2.1] and pressure test [8.1.1] are to be enclosed with the testing documentation.

**13.1.2** When the steel is cast in a mill other than that where the forgings are manufactured, the Surveyor is to be supplied with a steelmaker's certificate stating the manufacturing process, the grade of steel, the cast number and the relevant ladle analysis.

# Section 2 Forgings for Hull, Offshore Structures and Welded Components in General

## 1 Requirements

### 1.1 Scope

**1.1.1** The requirements of this Section apply to steel forgings intended for ship hull structures, such as sternframes, rudder horns, offshore structures and welded components in general, where design and acceptance tests are related to mechanical properties at ambient temperature.

### 1.2 Steel grades

**1.2.1** The grades are identified by the symbol FC (forgings in carbon and carbon-manganese steels) or FA (forgings in alloy steels), followed by a number giving the minimum specified ultimate tensile strength  $R_m$ , in N/mm<sup>2</sup>.

**1.2.2** Where it is proposed to use alloy steels, the specification of the steel grade (chemical composition, heat treatment and mechanical properties) is to be submitted for approval.

### 1.3 Manufacture

#### 1.3.1 Approval

Forgings having a mass above 1000 kg or with a diameter above 200 mm are to be manufactured at works which are approved by the Society. Provisions are given in Sec 1, [3].

### 1.4 Condition of supply

**1.4.1** The forgings are to be supplied in one of the following conditions, as appropriate:

- Carbon and carbon-manganese steels:
  - fully annealed
  - normalized
  - normalized and tempered
  - quenched and tempered
- Alloy steels:
  - normalized
  - normalized and tempered
  - quenched and tempered.

For all types of steel the tempering temperature is to be not less than 550°C.

The delivery condition shall meet the design and application requirements, it is the manufacturers responsibility to select the appropriate heat treatment method to obtain the required mechanical properties.

### 1.5 Chemical composition

**1.5.1** Reference is made to Sec 1, [5]. The chemical composition on ladle analysis is to comply with the limits given in Tab 1 or, where applicable, the requirements of the approved specification.

**1.5.2** Maximum carbon equivalent ( $C_{EQ}$ ) value specified for forgings for offshore structures and components is to be agreed with the Society.

### 1.6 Mechanical properties

**1.6.1** Tab 2 gives the minimum requirements for yield stress, elongation, reduction of area and impact test energy values corresponding to different strength levels. Where it is proposed to use a steel with a specified minimum tensile strength intermediate to those given, corresponding minimum values for the other tensile properties may be obtained by interpolation.

**1.6.2** Forgings intended for the poop structure of ships with ice class notation are to be Charpy V-notch impact tested at 0°C with 27 J minimum average energy in longitudinal direction.

**1.6.3** For forgings operating at 0°C or lower temperature, which are not dealt with in this Section, the applicable requirements are to be agreed with the Society depending on the design temperature, application and dimensions; see also Sec 8.

**1.6.4** Charpy V-notch impact tests requirements applicable to forgings for offshore structures and components are to be agreed with the Society in accordance with the Society’s Offshore Rules.

**1.7 Mechanical tests**

**1.7.1** One set of tests is to be taken from the end of each forging in a longitudinal direction except that, at the discretion of the manufacturer, the alternative directions or positions as shown in Sec3 Fig 2, Fig 3 or Fig 4 may be used.

**1.7.2** In the case of individual testing as in Sec 1, [7.2.1], at least one test sample is to be taken for the required tests.

Where a forging exceeds both 4 tonnes in mass and 3 m in length, one test sample is to be taken from each end. These limits refer to the as forged mass and length but excluding the test material.

**1.7.3** In the case of batch testing, the number of test samples is given in Sec 1, [7.3.1].

**1.7.4** The test specimens for 1 tensile and 3 Charpy V-notch impact tests are to be taken from each test sample.

Unless otherwise agreed the tests specimens are to be cut in a longitudinal direction as per Sec 1, [7.6.1].

**1.8 Non-destructive examination**

**1.8.1** Magnetic particle and ultrasonic examination are to be carried out on forgings and as mentioned in Sec 1, [10].

**Table 1 : Chemical composition limits**

Steel type	C	Si	Mn	P	S	Cr	Mo	Ni	Cu (2)	Total residuals
C, C-Mn	0,23 (1)	0,45	0,30-1,50	0,035	0,035	0,30 (2)	0,15 (2)	0,40 (2)	0,30	0,85
Alloy	(3)	0,45	(3)	0,035	0,035	(3)	(3)	(3)	0,30	–

**Note 1:** Composition given in percentage mass by mass maximum unless shown as a range.

(1) The carbon content may be increased above this level provided that the carbon equivalent ( $C_{EQ}$ ), in %, is not more than 0,41% calculated using the following formula, except for forgings intended for offshore structures where maximum  $C_{EQ}$  values are to be agreed with the Society:

$$C_{EQ} = C + \frac{Mn}{6} + \frac{Cr + Mo + V}{5} + \frac{Ni + Cu}{15}$$

(2) Elements are considered as residual elements.

(3) Specification is to be submitted for approval.

**Table 2 : Mechanical properties for hull steel forgings**

Steel type	Tensile strength $R_m$ min. (N/mm <sup>2</sup> ) (1)	Yield stress $R_{eH}$ min. (N/mm <sup>2</sup> )	Elongation $A_5$ min. (%)		Reduction of area Z min. (%)		Charpy V-notch impact test (2)		
			Long.	Tang.	Long.	Tang.	Test temperature (°C)	Minimum average energy (J)	
C and C-Mn	400	200	26	19	50	35	0	Long.	Tang.
	440	220	24	18	50	35		27	18
	480	240	22	16	45	30			
	520	260	21	15	45	30			
	560	280	20	14	40	27			
	600	300	18	13	40	27			
Alloy	550	350	20	14	50	35	0		
	600	400	18	13	50	35			
	650	450	17	12	50	35			

(1) The following ranges for tensile strength may be additionally specified:

- specified minimum tensile strength: < 600 N/mm<sup>2</sup> ≥ 600 N/mm<sup>2</sup>
- tensile strength range: 120 N/mm<sup>2</sup> 150 N/mm<sup>2</sup>.

(2) Special consideration may be given to alternative requirements for Charpy V-notch test, depending on design and application, and subject to agreement by Society.



# Section 3 Forgings for Machinery, Shafts and Non-Welded Components in General

## 1 Requirements

### 1.1 Scope

**1.1.1** The requirements of this Section apply to carbon, carbon-manganese and alloy steel forgings, intended for use in the construction of machinery, shafts and non-welded components including offshore equipment like rings for slewing bearings of cranes and offshore loading systems.

Specific requirements for anchors are given in Ch 10, Sec 1.

**1.1.2** When welding is expected on rudder stocks, tillers and pintles, the requirements of Sec 2 apply, unless otherwise agreed by the Society.

### 1.2 Steel grades

**1.2.1** The grades are identified by one of the symbols FC (forgings in carbon and carbon-manganese steels) or FA (forgings in alloy steels), followed by a number giving the specified minimum tensile strength  $R_m$  in N/mm<sup>2</sup>.

### 1.3 Manufacture

#### 1.3.1 Approval

Forgings having a mass above 1000 kg or with a diameter above 200 mm are to be manufactured at works which are approved by the Society. Provisions are given in Sec 1, [3].

### 1.4 Condition of supply

**1.4.1** The forgings are to be supplied in one of the following conditions, as appropriate:

- Carbon and carbon-manganese steels:
  - fully annealed
  - normalized
  - normalized and tempered
  - quenched and tempered
- Alloy steels:
  - normalized
  - normalized and tempered
  - quenched and tempered.

The delivery condition shall meet the design and application requirements, it is the manufacturers responsibility to select the appropriate heat treatment method to obtain the required mechanical properties.

For all types of steel the tempering temperature is to be not less than 550°C.

### 1.5 Chemical composition

#### 1.5.1 General

Reference is made to Sec 1, [5]. The chemical composition on ladle analysis is to comply with the limits given in Tab 1 or, where applicable, the requirements of the approved specification.

### 1.6 Mechanical properties

**1.6.1** Tab 2 gives the minimum requirements for yield stress, elongation, reduction of area corresponding to different strength levels. Where it is proposed to use a steel with a specified minimum tensile strength intermediate to those given, corresponding minimum values for the other tensile properties may be obtained by interpolation.

**1.6.2** Forgings intended for propeller shafts, rudder stocks, pintles, blade bolts, CP mechanisms, shaft bolts, strut-pod connecting bolts of ships with ice class notation **ICE CLASS IA SUPER**, **ICE CLASS IA**, **ICE CLASS IB** or **ICE CLASS IC** are to be Charpy V-notch impact tested at -10°C with 20 J minimum average energy in longitudinal direction.



**1.6.3** For forgings operating at 0°C or lower temperature, which are not dealt with in this Section, the applicable requirements are to be agreed with the Society depending on the design temperature, application and dimensions; see also Sec 8.

**1.6.4** Unless otherwise agreed with the Society, carbon and carbon-manganese steel forgings intended for offshore equipment are to be Charpy V-notch impact tested with 27 J minimum average energy in longitudinal direction at a temperature to be agreed with the Society in accordance with Tab 3.

Alloy steel forgings intended for offshore equipment are to be Charpy V-notch tested in accordance with the approved specifications.

**Table 1 : Chemical composition limits for non-welded components**

Steel type	C	Si	Mn	P	S	Cr (1)	Mo (1)	Ni (1)	Cu (1)	Total residuals
C, C-Mn	0,65	0,45	0,30-1,50	0,035	0,035	0,30	0,15	0,40	0,30	0,85
Alloy	0,45	0,45	0,30-1,00	0,035	0,035	min. 0,40 (2)	min. 0,15 (2)	min. 0,40 (2)	0,30	–

**Note 1:** Composition given in percentage mass by mass maximum unless shown as a range or as a minimum.

(1) Elements are considered as residual elements unless shown as a minimum.

(2) One or more of the elements is to comply with the minimum content.

**Table 2 : Mechanical properties for machinery steel forgings**

Steel type	Tensile strength R <sub>m</sub> min. (N/mm <sup>2</sup> ) (1)	Yield stress R <sub>eH</sub> min. (N/mm <sup>2</sup> )	Elongation A <sub>5</sub> min. (%)		Reduction of area Z min. (%)		Hardness (Brinell) (3)	Charpy V-notch impact test (2) (4)		
			Long.	Tang.	Long.	Tang.		Test temperature (°C)	Minimum average energy (J)	
C and C-Mn	400	200	26	19	50	35	110-150	AT (5)	27	18
	440	220	24	18	50	35	125-160			
	480	240	22	16	45	30	135-175			
	520	260	21	15	45	30	150-185			
	560	280	20	14	40	27	160-200			
	600	300	18	13	40	27	175-215			
	640	320	17	12	40	27	185-230			
	680	340	16	12	35	24	200-240			
	720	360	15	11	35	24	210-250			
Alloy	760	380	14	10	35	24	225-265			
	600	360	18	14	50	35	175-215			
	700	420	16	12	45	30	205-245			
	800	480	14	10	40	27	235-275			
	900	630	13	9	40	27	260-320			
	1000	700	12	8	35	24	290-365			
	1100	770	11	7	35	24	320-385			

(1) The following ranges for tensile strength may be additionally specified:

- specified minimum tensile strength: < 900 N/mm<sup>2</sup> ≥ 900 N/mm<sup>2</sup>
- tensile strength range: 150 N/mm<sup>2</sup> 200 N/mm<sup>2</sup>.

(2) For materials used for machinery exposed to sea water temperature, such as propeller shafts and shaft bolts, intended for ships with ice class notation **ICE CLASS IA SUPER**, **ICE CLASS IA**, **ICE CLASS IB** and **ICE CLASS IC**, Charpy V-notch impact testing is to be carried out for all steel types at -10°C and the average energy value is to be minimum 20 J (longitudinal test). One individual value may be less than the required average value provided that it is not less than 70% of this average value.

(3) The hardness values are typical and are given for information purposes only.

(4) Special consideration may be given to alternative requirements for Charpy V-notch test, depending on design and application, and subject to agreement by Society.

(5) AT refers to Ambient Temperature (i.e. 23°C±5°C), which is specified in ISO 148-1:2016.

**Table 3 : Charpy V-notch test temperature for carbon and carbon-manganese steel forgings intended for offshore equipment**

Yield stress $R_{eH}$ min. (N/mm <sup>2</sup> )	$T_D$ (°C)	$T_{CVN}$ (°C)
235	+20	+10
	+10	0
	0	-10
	-10	-20
355	+20	0
	+10	-10
	0	-15
	-10	-20
460	+20	0
	+10	-10
	0	-20
	-10	-30
690	+20	-20
	+10	-30
	0	-40
	-10	-40

**Note 1:**  
 $T_D$  : Design temperature  
 $T_{CVN}$  : Charpy V-notch impact test temperature.

**1.7 Mechanical tests**

**1.7.1** In the case of individual testing as in Sec 1, [7.2.1], at least one test sample is to be taken for the required tests.

Where a forging exceeds both 4 tonnes in mass and 3 m in length, one test sample is to be taken from each end. These limits refer to the as forged mass and length but excluding the test material.

**1.7.2** In the case of batch testing, the number of test samples is given in Sec 1, [7.3.1].

**1.7.3** The test specimens for 1 tensile test and, when required, 3 Charpy V-notch impact tests are to be taken from each test sample.

The tests specimens are to be cut in a longitudinal direction except that, at the discretion of the Manufacturer, the alternative directions or positions as shown in Fig 1, Fig 2 and Fig 3 may be used.

For forged rings, such as slewing rings, one set of tests is to be taken from each forging in a tangential direction (test positions are shown in Fig 4). Where the finished diameter exceeds 2,5 m or the mass (as heat treated, including test material) exceeds 3 tonnes then two sets of tests are to be taken diametrically opposite positions.

**Figure 1 : Plain shaft**

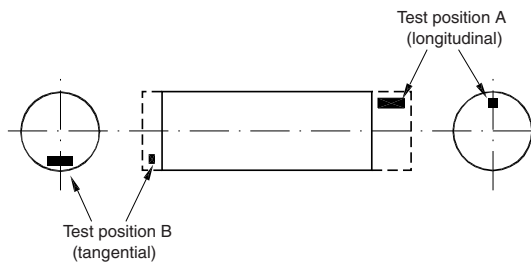

**Figure 2 : Flanged shaft**

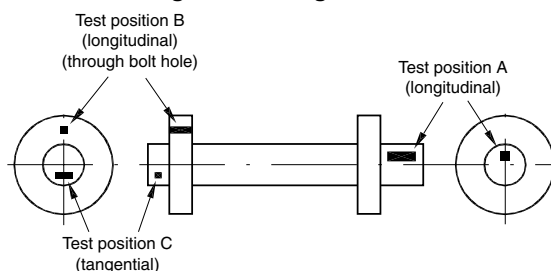

Figure 3 : Flanged shaft with collar

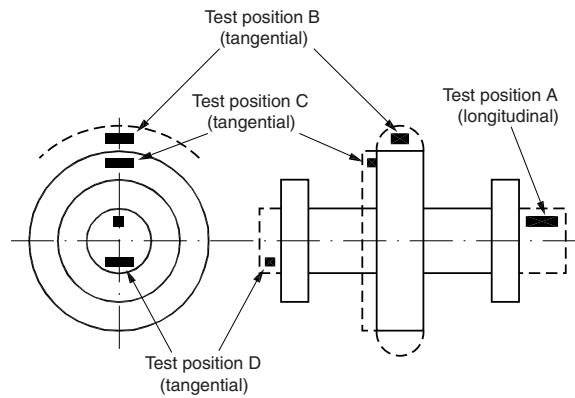
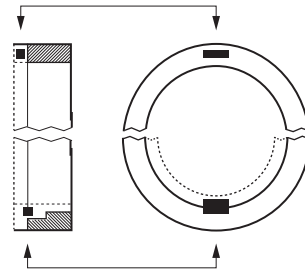

Figure 4 : Forged rings

Examples of acceptable tangential test positions



## 1.8 Non-destructive examination

1.8.1 A magnetic particle or liquid penetrant examination is to be carried out on forgings intended for:

- rudder stocks and pintles with diameter not lower than 100 mm
- main propulsion shafting with diameter not lower than 100 mm
- connecting rods, crossheads
- components for engines having bore diameter larger than 300 mm, such as:
  - cylinder heads
  - bolts and studs for cylinder head, crossheads, main bearings and connecting rods
- components for engines having bore diameter larger than 400 mm, such as:
  - piston crowns, piston rods, tie rods, gear wheels for camshaft drives
  - nuts for tie rods
- coupling bolts for crankshafts
- propeller blade fastening bolts which are subjected to dynamic stresses.

The magnetic particle test of tie rods/stay bolts is to include test at each threaded portion which is at least twice the length of the thread.

1.8.2 Ultrasonic testing is to be carried out on the following items:

- rudder stocks and pintles with diameter not lower than 200 mm
- shafts having a finished diameter of 200 mm or larger, when intended for main propulsion or other essential services
- piston crowns, cylinders covers, crossheads
- connecting rods, piston rods with minimum diameter not less than 200 mm or equivalent cross-section
- components for engines having bore diameter larger than 300 mm, such as:
  - bolts and studs for cylinder head, crossheads, main bearings and connecting rods.

# Section 4 Forgings for Crankshafts

## 1 Requirements

### 1.1 Scope

**1.1.1** The requirements of this Section apply to carbon-manganese and alloy steel for solid forged crankshafts and forgings to be used for the construction of semi-built or fully built crankshafts.

The general requirements, specified in Sec 1, are also to be complied with, as appropriate.

### 1.2 Steel grades

**1.2.1** The steel specification relevant to chemical composition, mechanical properties and heat treatment is to be submitted for approval.

**1.2.2** The specified minimum tensile strength  $R_m$  is generally to be not lower than 400 N/mm<sup>2</sup> and not higher than 1000 N/mm<sup>2</sup>.

### 1.3 Manufacture

#### 1.3.1 Approval

Forgings having a mass above 1000kg are to be manufactured at works which are approved by the Society. Provisions are given in Sec 1, [3].

**1.3.2** Continuous grain flow forging procedures are to be specially approved and, to this end, tests effected to demonstrate that a satisfactory structure and grain flow are obtained.

In the case of a welded crankshaft, the welding procedure is to be approved.

When the webs are obtained by flame cutting from forged or rolled flat products, the part to be removed by machining is to be not less than 8 mm from all flame-cut surfaces.

### 1.4 Condition of supply

**1.4.1** Forgings are to be normalised and tempered or quenched and tempered depending on the approved specification. The tempering temperature is to be not lower than 550°C.

**1.4.2** Where a superficial hardening of the crankshaft forging by nitriding or by induction quenching is foreseen, the proposed procedure is to be submitted as indicated in Sec 1, [6.1.8].

### 1.5 Chemical and mechanical properties

**1.5.1** The chemical composition on ladle analysis is to comply with the approved specification [1.2.1].

For alloy steels which are to be nitrided, the phosphorus or sulphur content is to be not greater than 0,020%.

**1.5.2** The mechanical properties are to comply with the requirements of the approved specification.

### 1.6 Mechanical tests

**1.6.1** For open die solid forged crankshafts one set of test specimens is to be taken in the longitudinal direction, from the driving shaft end of each forging (test position A in Fig 1).

Where the mass (as heat treated but excluding test material) exceeds 3 tonnes, the specimens in a longitudinal direction are to be taken from each end (test positions A and B in Fig 1). Where however the crankthrows are formed by machining or flame cutting, the second set of specimens is to be taken in a tangential direction from material removed from the crankthrow at the end opposite to the driving shaft end (test position C in Fig 1).

**1.6.2** For crank webs, one set of specimens is to be taken from each forging in a tangential direction (test position C in Fig 1).

**1.6.3** For closed die crankshaft forgings and crankshaft forgings where the method of manufacture has been specially approved in accordance with [1.3], the number and position of test specimens is to be agreed with the Society having regard to the method of manufacture used.

**1.6.4** When small crankshaft forgings are batch tested Sec 1, [7.3.1], hardness tests are to be made on the individual pieces and results are to be reported.

Figure 1 : Solid forged crankshaft

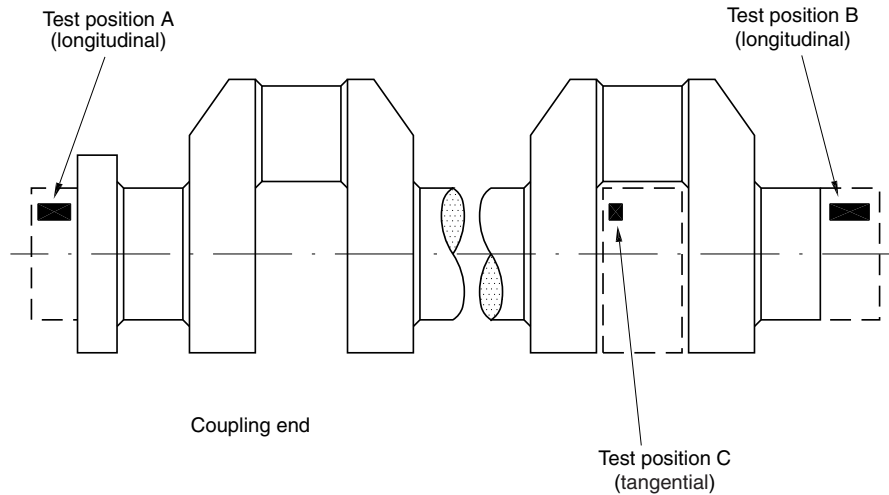

**1.7 Non-destructive examination**

**1.7.1** Magnetic particle and/or liquid penetrant tests are required for all crankshaft forgings. Where applicable, this is also to include all flame-cut surfaces not subsequently machined. Special care is to be devoted to the pins and journals and associated fillets. Unless otherwise agreed, all crankshaft forgings are to be ultrasonically examined.

**1.7.2** Non-destructive examination procedures and the acceptance criteria of the indications of such tests, complying with the requirements of the engine Manufacturer, are to be previously approved by the Society.

# Section 5 Forgings for Gearing

## 1 Requirements

### 1.1 Scope

**1.1.1** The requirements of this Section apply to carbon-manganese and alloy steel forgings intended for the construction of gearing for main propulsion and auxiliary equipment.

The general requirements, specified in Sec 1, are also to be complied with, as appropriate.

**1.1.2** In the case of forgings for flexible couplings, quill shafts and gearwheel shafts, the requirements of Sec 3 apply.

### 1.2 Steel grades

**1.2.1** Steels are to comply with requirements specified in Sec 3, [1.2] or with a specification approved by the Society.

To this end, a detailed specification relevant to chemical composition, mechanical properties and heat treatment is to be submitted for approval.

### 1.3 Manufacture

#### 1.3.1 Approval

Forgings having a mass above 1000kg are to be manufactured at works which are approved by the Society. Provisions are given in Sec 1, [3].

**1.3.2** The reduction ratio during forging is to be in compliance with Sec 1, [2.1.2].

Forgings are to be provided with sufficient excess material as may be necessary for machining out possible defective zones.

### 1.4 Condition of supply

**1.4.1** Unless otherwise agreed, forgings which are not to be surface-hardened are to be normalised and tempered or quenched and tempered.

For all types of steel the tempering temperature is to be not less than 550°C.

The delivery condition shall meet the design and application requirements, it is the manufacturers responsibility to select the appropriate heat treatment method to obtain the required mechanical properties. Where forgings for gearing are not intended for surface hardening, lower tempering temperature may be allowed.

**1.4.2** Where induction hardening or nitriding is to be carried out, forgings are to be heat treated at an appropriate stage to a condition suitable for this subsequent surface hardening.

**1.4.3** Where carburising is to be carried out, forgings are to be heat treated at an appropriate stage (generally either by full annealing or by normalizing and tempering) to a condition suitable for subsequent machining and carburising.

**1.4.4** Treatments for surface hardening are to be approved in accordance with Sec 1, [6.1.8].

### 1.5 Chemical and mechanical properties

**1.5.1** The chemical composition and the mechanical properties are specified in Sec 3, [1.5] and Sec 3, [1.6], respectively, or in the approved specification as applicable.

### 1.6 Mechanical tests for normalised and tempered or quenched and tempered forgings

#### 1.6.1 Sampling

The specimens necessary for the required tests are to be taken from each forging Sec 1, [7.2.1] or a forging representative of the batch Sec 1, [7.3.1], in accordance with Fig 1, Fig 2, Fig 3 and Fig 4.

The set of test specimens is to be taken as follows:

- Pinions (see Fig 1):

Where the finished machined diameter of the toothed portion exceeds 200 mm, one set of test specimens is to be taken from each forging in a tangential direction adjacent to the toothed portion (test position B). Where the dimensions preclude the preparation of tests from this position, tests in a tangential direction are to be taken from the end of the journal (test position C).

If, however, the journal diameter is 200 mm or less, tests are to be taken in a longitudinal direction (test position A).

Where the finished length of the toothed portion exceeds 1,25 m, one set of test specimens is to be taken from each end.

Where the finished diameter of the toothed portion is 200 mm or less, one set of test specimens is to be taken in a longitudinal direction (test position A).

- Gear wheel (see Fig 2):

One set of tests is to be taken from each forging in a tangential direction (test positions A or B).

**Figure 1 : Pinions**

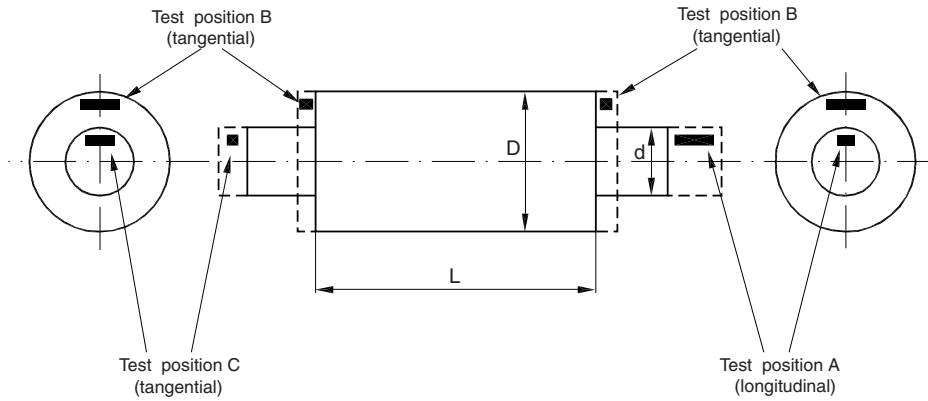

- L : Length of toothed portion, in mm
- D : Diameter of toothed portion, in mm
- d : Journal diameter, in mm.

**Figure 2 : Gear wheel**

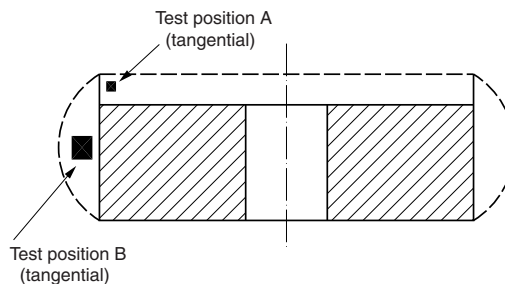

- Gear wheel rims made by expanding (see Fig 3):

One set of tests is to be taken from each forging in a tangential direction (test position A or B). Where the finished diameter exceeds 2,5 m or the mass (as heat treated including test material) exceeds 3 tonnes, two sets of test specimens are to be taken from diametrically opposite positions (test positions A and B). The mechanical properties for longitudinal tests are to be applied.

**Figure 3 : Gear wheel rim made by expanding**

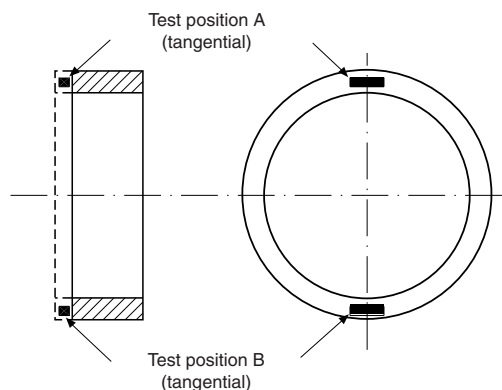

- Pinion sleeves (see Fig 4):

One set of test specimens is to be taken from each forging in a tangential direction (test position A or B). Where the finished length exceeds 1,25 m, one set of test specimens is to be taken from each end.

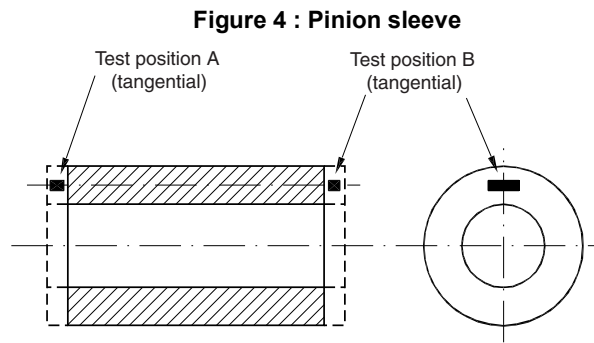

### 1.6.2 Hardness tests

Hardness tests may be required at the discretion of the Society. See also Sec 1, [7.9.1] a).

The hardness is to be determined after completion of heat treatment and prior to machining the gear teeth.

Measurements are to be carried out at four positions equally spaced around the circumference of the surface where teeth will subsequently be cut. Where the finished diameter of the toothed portion exceeds 2,5 m, the above number of test positions is to be increased to eight.

Where the width of a gear wheel rim forging exceeds 1,25 m, the hardness is to be determined at eight positions at each end of the forging.

## 1.7 Mechanical tests for surface-hardened forgings

### 1.7.1 Sampling

Forgings to be carburised after machining are to be provided with sufficient test material for the sets of specimens for both preliminary tests at the forge and final tests after completion of carburising.

For this purpose two test samples are to be taken from positions as detailed in [1.6] except that irrespective of the dimensions or mass of the forging, tests are required from one position only and, in the case of forgings with integral journals, are to be cut in a longitudinal direction.

This test sample is to be machined to a diameter of  $D/4$  or 60 mm, whichever is less, where  $D$  is the finished diameter of the toothed position.

For preliminary tests at the forge, one test sample is to be given a blank carburising and heat treatment cycle, simulating that which subsequently will be applied to the forging.

For final acceptance tests, the second test sample is to be blank carburised and heat treated along with the forgings they represent.

At the discretion of the Manufacturer, test samples of larger cross-section may be either carburised or blank carburised, but these are to be machined to the required diameter prior to the final quenching and tempering heat treatment.

### 1.7.2 Hardness tests and additional checks

Hardness tests may also be required on forgings which have been induction hardened, nitrided or carburised. See also Sec 1, [7.9.1] b).

The hardness is to be determined on the toothed part after the teeth have been ground to the finished profile. The results of such tests are to comply with the approved specification.

Additional checks of the hardness, depth and shape of the hardened layer are to be performed as indicated in the approved specification.

When, for nitrided gearing, hardness verification is required on additional test samples, unless otherwise stated in the approved specification, the depth of the hardened zone is to be not lower than 0,6 mm and the hardness at a depth of 0,25 mm is to be not lower than 500 Vickers points.

## 1.8 Non-destructive examination

**1.8.1** Magnetic particle or liquid penetrant testing is required on the tooth surfaces of gears hardened completely or at their surface.

An ultrasonic examination of the forgings is to be performed by the Manufacturer when there is still an adequate amount of excess material on the surfaces in respect of the final position of the teeth.

In general, ultrasonic examination is required for forging having a finished diameter, of the part where teeth will be cut, higher than 200 mm.



# Section 6 Forgings for Turbines

## 1 Requirements

### 1.1 Scope

**1.1.1** The requirements of this Section apply to steel forgings intended for the construction of rotors and discs of main turbines and rotors of auxiliary turbines driving electric generators and compressors.

The general requirements specified in Sec 1 are also to be complied with, as appropriate.

**1.1.2** Plans submitted for approval are to state whether the turbine is for propulsion or for auxiliary service; in the latter case the shaft power is to be specified.

For rotors to be subjected to a thermal stability test, the maximum design temperature and the proposed test temperature are also to be specified.

For rotors of welded construction, the specification of the chemical composition of the steel is to be submitted for approval.

### 1.2 Steel grades, chemical composition and mechanical properties

**1.2.1** The steel grades and relevant properties may be in accordance with Sec 3, [1.2], Sec 3, [1.5] and Sec 3, [1.6] or with a particular specification to be submitted for acceptance.

### 1.3 Manufacture

#### 1.3.1 Approval

Forgings having a mass above 1000kg are to be manufactured at works which are approved by the Society. Provisions are given in Sec 1, [3].

### 1.4 Condition of supply

**1.4.1** The intermediate and final heat treatments, specified by the Manufacturer, are to be submitted for consideration.

In particular, the heat treatments are to be such as to avoid hair-line cracks.

For rotors of welded construction, the heat treatment is to be specially approved.

### 1.5 Mechanical tests

**1.5.1** For rotors not exceeding 3 tonnes in mass, one set of longitudinal specimens is to be taken from one end of the shaft and one set of transverse test specimens is to be taken in the tangential direction from the body portion (see Fig 1).

For rotors exceeding 3 tonnes in mass, the set of longitudinal specimens is to be taken from each end of the shaft and the set of transverse test specimens is to be taken in the tangential direction from the body portion (see Fig 1).

For each turbine disc, at least one set of transverse specimens is to be taken from the boss in the tangential direction (see Fig 2).

**Figure 1 : Turbine rotor**

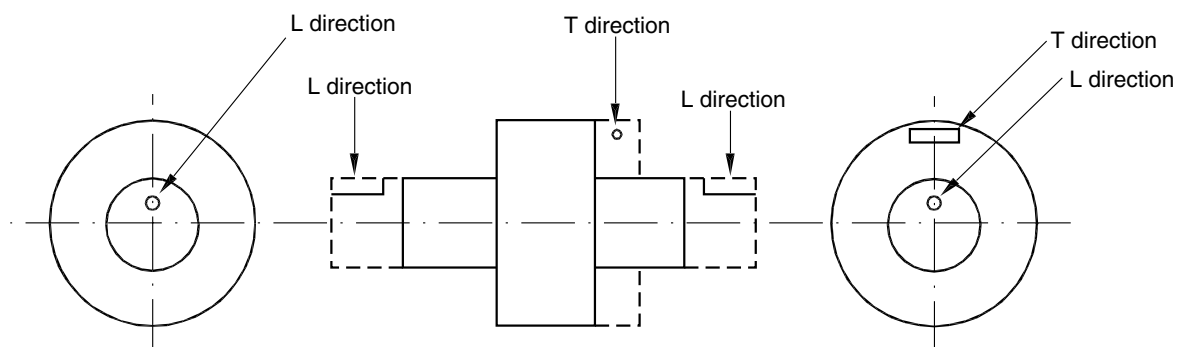
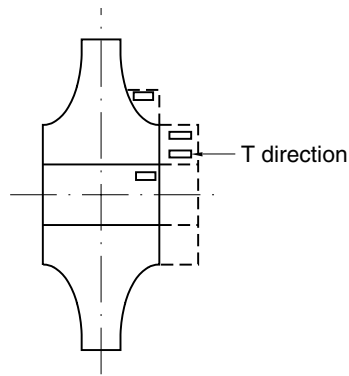

Figure 2 : Turbine disc



## 1.6 Non-destructive examination

**1.6.1** A visual examination, supported by a magnetic particle examination at the discretion of the Surveyor, is required for the end surfaces of the rotors and the boss of the discs; the degree of finishing is to be appropriate for this purpose.

An ultrasonic examination is to be carried out by the Manufacturer on all forgings.

**1.6.2** Rotor forgings for propulsion turbines having a power exceeding 1100 kW are to be hollow bored to permit internal examination visually and, where possible, by the magnetic particle method.

At the discretion of the Society, ultrasonic examination of the rotor by an approved procedure may be accepted as an alternative to hollow boring.

## 1.7 Thermal stability test

**1.7.1** Solid forged rotors and rotors built by welding two or more forged pieces and intended for turbines having a design temperature exceeding 400°C are to be subjected, after the final heat treatment and in their rough machined condition, to a thermal stability test.

The test is to be performed using procedures and equipment to the satisfaction of the Society.

The deflection may be measured with the procedure outlined below, which consists in reading the radial elongation in way of some machined zones distributed along the length of the rotor (in general, there will be two reference machined zones in way, or in proximity, of the supports and three test machined zones located one at the mid-length and two at the ends of the rotor).

Four markings, 90° apart, are to be stamped for identification on the coupling end of the rotor.

During the test, the rotor is to be rotated very slowly and uniformly in the furnace, while it is heated gradually and evenly, excessive thermal gradients being avoided; the rotor is to be maintained for a sufficient length of time at the specified test temperature, which is to be appropriate to the final heat treatment of the piece, and subsequently slowly and uniformly cooled to a sufficiently low temperature, excessive thermal gradients again being avoided.

In the course of the test, the deflections are to be regularly recorded in each machined zone, at angular intervals of 90°, and the difference in the readings between the cold and hot conditions is not to exceed the specified limits.

In general, the following requirements are to be complied with:

- the furnace is to be large enough to contain the whole length of the rotor, including the end zones in way of the glands; overhung wheels, when present, are also to be enclosed in the furnace
- means are to be provided for continuous recording of the temperature at the surface of the rotor and, if practicable, in a bore at the mid-length of the rotor
- the temperature of the rotor is in no case to exceed the final tempering temperature
- the test temperature is to not be less than the maximum design temperature +28°C but not higher than the temperature mentioned above; the temperature distribution is to be uniform and maintained at a constant level for at least three hours with the readings falling within 0,006 mm in all the machined zones
- the rotor is to be rotated during cooling until the temperature is not more than 100°C
- cold readings are to be taken before and after the test.

The test results are considered satisfactory when the difference between the final readings in the hot conditions and the initial and final cold readings do not exceed 0,025 mm in any zone.

Otherwise, at the request of the Manufacturer and with the Society's approval, the test may be repeated; when the results of the second test are also unsatisfactory, proposals for alterations to the rotor are to be approved by the Society before further testing.

# Section 7 Forgings for Boilers, Pressure Vessels and Systems

## 1 Requirements

### 1.1 Scope

**1.1.1** The requirements of this Section apply to forgings made in carbon, carbon-manganese, molybdenum and chromium-molybdenum low alloy steels, intended for the construction by welding of boilers and pressure vessels, plants and piping systems in general, when Charpy V-notch properties at temperature not lower than  $-20^{\circ}\text{C}$  are specified.

For forgings not intended for welded constructions, the requirements of Sec 2 apply, as appropriate.

**1.1.2** Forgings intended for vessels and systems operating at low temperatures are to comply with the applicable requirements of Sec 8 and, in the case of applications involving the storage and transport of liquefied gases or fluids at low temperature, reference is to be made to the Society's Rules for the Classification of Steel Ships, NR467, Part D, Chapter 9, and, to the International Code for the Construction and Equipment of Ships Carrying Liquefied Gases in Bulk (IGC Code).

For gas fuelled ships, reference is to be made to Society Rule Note NR529, and, to the International Code of Safety for Ships using Gases or other Low-flash point Fuels (IGF Code).

### 1.2 Steel grades

**1.2.1** Carbon and carbon-manganese steels are classed into three groups indicating the minimum ultimate tensile strength  $R_m$ , in  $\text{N/mm}^2$ : 410, 460 and 510.

Each group may be further subdivided into grades HA, HB and HD, based on conventional levels of quality and impact properties.

**1.2.2** Low alloy steels are designated according to the chemical composition in the grades 0,3Mo-1Cr0,5Mo-2,25Cr1Mo. The figures mean the nominal percentage content of the main alloying elements.

Where it is proposed to use steels other than those dealt with in these Rules, the steel specification relevant to chemical composition, mechanical properties and heat treatment is to be submitted for approval.

### 1.3 Manufacture

#### 1.3.1 Approval

Forgings having a mass above 1000kg are to be manufactured at works which are approved by the Society. Provisions are given in Sec 1, [3].

### 1.4 Condition of supply

**1.4.1** The forgings are to be supplied in one of the following conditions, as appropriate:

- Carbon and carbon-manganese steels:
  - normalized
  - normalized and tempered
  - quenched and tempered
- Alloy steels:
  - quenched and tempered.

Alternatively, alloy steel forgings may be supplied in the normalized and tempered condition, in which case the specified mechanical properties are to be agreed with the Society.

For all types of steel the tempering temperature is to be not less than  $550^{\circ}\text{C}$ .

### 1.5 Chemical composition

**1.5.1** The chemical composition on ladle analysis is to comply with the limits specified in Tab 1 for carbon and carbon-manganese forgings and Tab 2 for Cr and Cr-Mo alloy steel forgings.

### 1.6 Mechanical properties

**1.6.1** The mechanical properties are specified in Tab 3 for carbon and carbon-manganese steel and in Tab 4 for Cr and Cr-Mo alloy steel forgings.

**Table 1 : Carbon and carbon-manganese steels - Chemical composition**

Steel grade	Deoxidation	Chemical composition (%) (1)						
		C max	Mn	Si	P max	S max	Al tot. min. (1)	Ni max
410 HA	killed	0,20	0,60 - 1,40	0,10 - 0,40	0,030	0,030		0,40
410 HB	killed							
410 HD	killed and fine grained							
460 HA	killed	0,22	0,90 - 1,60	0,10 - 0,50	0,030	0,030		0,40
460 HB	killed							
460 HD	killed and fine grained							
510 HA	killed	0,23	1,00 - 1,60	0,10 - 0,50	0,030	0,030		0,40
510 HB	killed							
510 HD	killed and fine grained							

(1) Nb, V or Ti may be used for grain refining as a complete or partial substitute for Al, in which case the minimum value for Al content does not apply. The grain refining elements are to be specified at the time of approval; in general Nb and V are not to exceed 0,05% and 0,10%, respectively. Additional alloying elements are to be submitted for consideration and approval. Residual elements not intentionally added are not to exceed the following limits: Cu ≤ 0,30%; Cr ≤ 0,25%; Mo ≤ 0,10%. Total: Ni + Cu + Cr + Mo ≤ 0,80%

**Table 2 : Low alloy steels - Chemical composition**

Steel grade	Deoxidation (2)	Chemical composition (%) (1)						
		C	Mn	Si	P max	S max	Cr	Mo
0,3Mo	Si killed	0,12 - 0,22	0,40 - 0,90	0,10 - 0,40	0,030	0,030	-	0,25 - 0,35
1Cr 0,5Mo	Si killed	≤ 0,18	0,40 - 1,70	0,10 - 0,40	0,030	0,030	0,80 - 1,15	0,40 - 0,65
2,25Cr 1Mo	Si killed	≤ 0,15	0,10 - 0,40	0,10 - 0,40	0,030	0,030	2,00 - 2,50	0,90 - 1,10

(1) Residual elements are not to exceed the following limits: Cu ≤ 0,30%; Ni ≤ 0,30%.  
(2) Aluminum total is to be lower than 0,020% for all grades of steel. The aluminum content is to be mentioned on the ladle analysis certificate.

**Table 3 : Carbon and carbon-manganese steels - Mechanical properties**

Steel grade	Yield stress R <sub>eH</sub> (N/mm <sup>2</sup> ) min. for thickness t (mm)		Tensile strength R <sub>m</sub> (N/mm <sup>2</sup> )	Elongation A <sub>5</sub> (%) min. for thickness t (mm) (1)				Average impact energy (J) min.				
	t ≤ 100	100 < t ≤ 250		t ≤ 100		100 < t ≤ 250		Test temp (°C)	KVL	KVT		
				L	T	L	T					
410 HA	230	220	410 - 530	24	23	23	21	+ 20	41	27		
410 HB								0			27	22
410 HD								- 20				
460 HA	260	250	460 - 600	23	21	22	20	+ 20	41	27		
460 HB								0			27	22
460 HD								- 20				
510 HA	280	270	510 - 650	21	20	20	19	+ 20	41	27		
510 HD								0				
510 HD								- 20				

(1) L and T stand for longitudinal and transverse specimens, respectively.

**1.7 Mechanical properties at elevated temperature**

**1.7.1** The values for the 0,2% proof stress (R<sub>p0,2</sub>) at temperatures of 150°C and higher are given in Tab 5.

The above values are for design purposes only. Their verification is in general not required during the testing, unless figures higher than those shown in Tab 5 and in accordance with recognised standards are proposed by the steel Manufacturer.

In such cases, the verification is required and the procedures detailed in [1.7.2] and [1.7.3] are to be followed.

**Table 4 : Low alloy steels - Mechanical properties**

Steel grade	Yield stress $R_{eH}$ (N/mm <sup>2</sup> ) min. for thickness $t$ (mm) (1)		Tensile strength $R_m$ (N/mm <sup>2</sup> )	Elongation $A_5$ (%) min. (2)		Average impact energy (J) min.		
	$t \leq 100$	$100 < t \leq 250$		L	T	Test temp (°C)	KVL	KVT
0,3Mo	285	270	440 - 570	23	21	+20	50	34
1Cr 0,5Mo	270	255	440 - 590	20	18		44	27
2,25Cr 1Mo	275	275	500 - 650	19	17		60	50

(1) For thickness or diameter greater than 250 mm, values are to be agreed with the Society.  
 (2) L and T stand for longitudinal and transverse specimens, respectively.

**Table 5 : Minimum proof stress ( $R_{p0,2}$ ) values at elevated temperatures**

Steel grade	Thickness (mm)	$R_{p0,2}$ (N/mm <sup>2</sup> ) at a temperature (°C) of							
		150	200	250	300	350	400	450	500
410 HA (1)	$\leq 100$	190	180	170	150	140	135	135	
410 HB (1)	$> 100$	175	170	160	150	140	135	135	
410 HD (1)	$\leq 100$	205	190	170	150	140	135	130	
	$> 100$	190	175	165	150	140	135	130	
460 HA (1)	$\leq 100$	215	210	195	175	170	160	155	
460 HB (1)	$> 100$	200	200	190	-	-	-	-	
460 HD (1)	$\leq 100$	235	215	200	175	165	155	150	
	$> 100$	220	200	190	175	-	-	-	
510 HB (1)	$\leq 100$	235	225	210	190	180	175	170	
	$> 100$	220	210	200	190	-	-	-	
510 HD (1)	$\leq 100$	255	235	215	190	180	170	165	
	$> 100$	240	215	205	190	-	-	-	
0,3Mo			200	185	170	160	150	140	130
1Cr 0,5Mo			210	200	180	170	160	150	140
2,25Cr 1Mo			240	230	220	210	200	190	180

(1) The values at  $R_{p0,2}$  for temperatures  $\leq 250^\circ\text{C}$  are for guidance only.

**1.7.2** When  $R_{p0,2}$  is required to be verified, at least one tensile test for each cast is to be carried out at the agreed temperature on each forging or batch of forgings.

The test specimen is to be taken near the position of the tensile specimen tested at ambient temperature.

The dimensions of the specimens and the testing procedure are to be in accordance with the requirements of Ch 2, Sec 2, [1.1] and Ch 2, Sec 2, [1.2.5], respectively.

The results of tests are to comply with the specified values.

**1.7.3** As an alternative to the systematic verification of the required  $R_{p0,2}$  as in [1.7.2], it may be agreed with the individual steelmakers to carry out an adequate program of tests or to adequately check the statistical data of the current production.

**1.7.4** The values of the estimated average stress to rupture in 100.000 hours are given, for design purposes only, in Ch 3, Sec 6, Tab 6.

## 1.8 Mechanical tests

**1.8.1** With the exception of drums (see [1.8.2]), at least one set of specimens for mechanical tests (1 tension and unless otherwise required 3 Charpy V-notch specimens for type HB and HD) is to be taken from each forging Sec 1, [7.2.1] or batch Sec 1, [7.3.1]; unless otherwise agreed and when possible, specimens are to be taken in the longitudinal direction.

**1.8.2** For drum forgings, one set of specimens for mechanical tests is to be taken from each open end.

When, depending on the manufacturing procedure, the test samples are to be detached before heat treatment, they are to be heat treated with the forging they represent.

The specimens are to be cut in the circumferential direction. Where the tensile test is carried out on specimens taken at both ends of a drum forging, the variation in tensile strength  $R_m$  on the two tests is not to exceed 70 N/mm<sup>2</sup>.

**1.8.3** For tensile tests at elevated temperatures, the requirements of [1.7.2] apply.

### 1.9 Non-destructive examination

**1.9.1** Unless otherwise required or agreed, at least the following non-destructive examinations are to be carried out:

- forgings are to be examined by the magnetic particle method
- drum forgings and other similar important forgings having thickness higher than 10 mm are to be examined by ultrasonic method.

# Section 8 Ferritic Steel Forgings for Low Temperature Service

## 1 Requirements

### 1.1 Scope

**1.1.1** The requirements of this Section apply to ferritic steel forgings intended for welded structural use as in the construction of structures, vessels, plants and piping systems for low temperature service or when, irrespective of the service conditions, they are required to satisfy specified impact properties at temperatures lower than  $-20^{\circ}\text{C}$ .

**1.1.2** In the case of applications involving the storage and transport of liquefied gases or fluids at low temperature, reference is to be made to the Society's Rules for the Classification of Steel Ships, NR467, Part D, Chapter 9, and, to the International Code for the Construction and Equipment of Ships Carrying Liquefied Gases in Bulk (IGC Code).

For gas fuelled ships, reference is to be made to Society Rule Note NR529, and, to the International Code of Safety for Ships using Gases or other Low-flash point Fuels (IGF Code).

### 1.2 Steel grades

**1.2.1** The requirements apply to carbon, carbon-manganese and nickel alloy steels.

The steel specification relevant to chemical composition, mechanical properties and heat treatment is to be submitted for approval.

Reference can be made to the steel designation, chemical composition and mechanical properties relevant to the rolled materials to which the forgings are intended to be welded, i.e. in particular, for these Rules, to Ch 3, Sec 7, Tab 1 and Ch 3, Sec 7, Tab 3 for carbon and carbon-manganese steels, and to Ch 3, Sec 7, Tab 2 and Ch 3, Sec 7, Tab 5 for nickel alloy steels.

### 1.3 Manufacture

#### 1.3.1 Approval

Forgings having a mass above 1000kg are to be manufactured at works which are approved by the Society. Provisions are given in Sec 1, [3].

### 1.4 Condition of supply

**1.4.1** Forgings are to be normalised, normalised and tempered or quenched and tempered, depending on the grade of steel, as indicated in Ch 3, Sec 10, [1.4.1] or in the approved specification.

### 1.5 Mechanical tests

**1.5.1** At least one set of specimens for mechanical tests (1 tensile and 3 Charpy V-notch specimens) is to be taken from each forging Sec 1, [7.2.1] or batch Sec 1, [7.3.1]; unless otherwise agreed and when possible, specimens are to be cut in the longitudinal direction.

The impact tests are generally to be carried out at the minimum temperature stated for the type of steel; a higher test temperature may be agreed with the Society, however, depending on the design temperature of the individual applications.

### 1.6 Non-destructive examination

**1.6.1** Unless otherwise required or agreed, forgings are to be examined by the magnetic particle method.

When the above forgings have thickness higher than 10mm, they are also to be subjected to ultrasonic examination.

# Section 9                      Stainless Steel Forgings

## 1 Requirements

### 1.1 Scope

**1.1.1** The requirements of this Section apply to stainless steel forgings intended for construction of cargo and storage tanks, pressure vessels, and piping fittings for chemical and/or low temperature applications.

**1.1.2** Austenitic stainless steels are suitable for use at both elevated and low temperatures where the design temperature is not lower than  $-165^{\circ}\text{C}$ .

When austenitic stainless steels are proposed for use at elevated temperatures, details of chemical composition, mechanical properties and heat treatment are to be submitted for consideration and approval.

**1.1.3** Stainless steels may also be used for shafts and machinery applications under Sec 3.

**1.1.4** In the case of applications involving the storage and transport of liquefied gases or fluids at low temperature, reference is to be made to the Society's Rules for the Classification of Steel Ships, NR467, Part D, Chapter 9, and, to the International Code for the Construction and Equipment of Ships Carrying Liquefied Gases in Bulk (IGC Code).

For gas fuelled ships, reference is to be made to Society Rule Note NR529, and, to the International Code of Safety for Ships using Gases or other Low-flash point Fuels (IGF Code).

### 1.2 Steel grades and relevant properties

**1.2.1** The requirements apply to austenitic Cr-Ni steels.

The general requirements relevant to designation, chemical composition, mechanical properties and condition of supply are specified in Ch 3, Sec 9 relevant to rolled products.

**1.2.2** Forgings made in stainless steels other than austenitic and intended for blade bolts, CP mechanisms, shaft bolts, strut-pod connecting bolts of ships having class notation **ICE CLASS IA SUPER**, **ICE CLASS IA**, **ICE CLASS IB** or **ICE CLASS IC** are to be Charpy V-notch impact, tested at  $-10^{\circ}\text{C}$  with 20 J minimum average energy in longitudinal direction.

**1.2.3** Other types of stainless steels (ferritic-austenitic or martensitic), complying with international or national specifications, may be accepted for particular applications (e.g. [1.1.3]); their relevant specification is to be submitted for approval.

### 1.3 Manufacture

#### 1.3.1 Approval

Forgings having a mass above 1000kg are to be manufactured at works which are approved by the Society. Provisions are given in Sec 1, [3].

### 1.4 Mechanical tests

**1.4.1** Sampling and mechanical tests are to be in compliance with the requirements of Sec 3, [1.7] and Sec 7, [1.8], as appropriate, depending on the application (machinery or pressure systems).

Unless otherwise required, impact tests on the austenitic grades are to be performed for a design temperature lower than  $-105^{\circ}\text{C}$  and are to be carried out at  $-196^{\circ}\text{C}$ .

The results of the tests are to be in accordance with the requirements of Ch 3, Sec 9, [1.6.1].

### 1.5 Non-destructive examination

**1.5.1** Unless otherwise required or agreed, forgings are to be examined by the liquid penetrant test and/or by the ultrasonic method, as appropriate, depending on the application.

### 1.6 Corrosion tests

**1.6.1** For forgings intended for chemicals, the corrosion tests, ASTM A262 Practice E (copper- copper sulphate sulphuric) or ASTM A262 Practice C (nitric acid test), as appropriate, may be required to be carried out on one piece per batch.

Tests in accordance with other recognised standards may be accepted subject to the agreement of the Society.



## CHAPTER 6 STEEL CASTINGS

---

Section 1	General Requirements
Section 2	Castings for Hull, Offshore Structures and Welded Components in General
Section 3	Castings for Machinery and Non-Welded Components in General
Section 4	Castings for Crankshafts
Section 5	Castings for Boilers, Pressure Vessels and Systems
Section 6	Ferritic Steel Castings for Low Temperature Service
Section 7	Stainless Steel Castings
Section 8	Stainless Steel Castings for Propellers

# Section 1 General Requirements

## 1 Scope

### 1.1 General

**1.1.1** The requirements of this Chapter apply to steel castings intended for hull, structural applications, offshore construction, machinery, propellers, boilers, pressure vessels and piping systems.

This Section specifies the requirements common to all the above-mentioned steel products, while the specific requirements for the various applications are indicated in Sec 2 to Sec 8.

### 1.2 Mass production

**1.2.1** For mass produced small castings, the Manufacturer may adopt particular procedures for testing and inspection subject to the approval of the Society.

### 1.3 Other specifications

**1.3.1** Steel castings complying with international, national or proprietary specifications may be accepted by the Society, provided such specifications give reasonable equivalence to the requirements of these Rules and other relevant Society's Rules or are approved for a specific application.

Such products, when accepted, are designated by their standard identification or as agreed at the time of the approval.

Unless otherwise agreed, survey and certification of steel castings complying with other specifications are to be carried out in accordance with the requirements of these Rules and other relevant Society's Rules.

### 1.4 Special requirements

**1.4.1** Special requirements may be specified in the case of applications intended for dangerous substances or for particularly severe service conditions.

In the case of applications involving the storage and transport of liquefied gases or fluids at low temperature, the reference is to be made to Society's Rules for the Classification of Steel Ships, NR467, Part D, Chapter 9, and, to the International Code for the Construction and Equipment of Ships Carrying Liquefied Gases in Bulk (IGC Code).

For gas fuelled ships, reference is to be made to Society Rule Note NR529, and, to the International Code of Safety for Ships using Gases or other Low-flash point (IGF Code).

## 2 Manufacturing

### 2.1 Steelmaking

**2.1.1** The steel is to be manufactured as detailed in Ch 3, Sec 1, [2.1.1].

### 2.2 Flame and arc-air shaping

**2.2.1** All flame cutting, scarfing or arc-air gouging to remove surplus metal is to be undertaken in accordance with recognised good practice and is to be carried out before the final heat treatment. Suitable preheating is to be applied when necessary due to the chemical composition and/or thickness of the casting. If necessary, the affected areas are to be either machined or ground smooth.

### 2.3 Welding of castings

**2.3.1** When two or more castings are joined by welding to form a composite component, the proposed welding procedure specification is to be submitted for approval.

Welding of steel castings intended for steel ship hull and welded structure is to be approved in accordance with Ch 12, Sec 3. Welding procedure qualification for others ship applications is to be approved in accordance with Ch 12, Sec 4.

Welders intended to be engaged in fusion welding of steel castings for hull structures are to be qualified in accordance with NR476.

Temporary welds made for operations such as lifting, handling, staging, etc., are to be in accordance with approved welding procedures and qualified welders, and are to be removed, ground and inspected using suitable NDT methods.

### **3 Approval**

#### **3.1 Casting process**

**3.1.1** Manufacturers of steel castings are to be recognised by the Society in accordance with NR320.

**3.1.2** When required in the relevant Sections, provisions for approval of manufacturing process are given in NR480.

### **4 Quality of materials**

#### **4.1 General requirements**

**4.1.1** All castings are to be free from surface or internal defects which would be prejudicial to their proper application in service.

**4.1.2** The surface finish is to be in accordance with good practice and any specific requirements of the approval plan.

### **5 Chemical composition**

#### **5.1 General requirements**

**5.1.1** All castings are to be made from killed steel and the chemical composition is to be appropriate for the type of steel and the mechanical properties specified for the castings.

**5.1.2** The chemical composition of each heat is to be determined by the manufacturer on a sample taken preferably during the pouring of the heat. When multiple heats are tapped into a common ladle, the ladle analysis shall apply.

**5.1.3** Unless otherwise required suitable grain refining elements such as aluminium may be used at the discretion of the manufacturer. The content of such elements is to be reported.

**5.1.4** Carbon equivalent ( $C_{EQ}$ ) values, when used in this Chapter, are calculated using the following formula:

$$C_{EQ} = C + \frac{Mn}{6} + \frac{Cr + Mo + V}{5} + \frac{Ni + Cu}{15} \quad \%$$

### **6 Heat treatment**

#### **6.1 General requirements**

**6.1.1** Castings are to be suitably heat treated to obtain the required mechanical properties.

Heat treatment is to be carried out in suitable furnaces. See Ch 1, Sec 1, [2.3.1].

**6.1.2** The heat treatment conditions foreseen are given in the Sections relevant to the various castings.

When more than one heat treatment condition is specified, the choice of the supply condition, unless otherwise required, is left to the Manufacturer; the condition of supply is always to be mentioned in the testing documentation.

**6.1.3** If a casting is locally reheated or any straightening operation is performed after the final heat treatment, a subsequent stress relieving heat treatment may be required in order to avoid the possibility of harmful residual stresses. The manufacturer shall have strict control of this temperature in order to avoid any detrimental effects to the final heat treatment and resultant microstructure and mechanical properties of the casting.

**6.1.4** The foundry is to maintain records of heat treatment identifying the furnace used, furnace charge, date, temperature and time at temperature. The records are to be presented to the surveyor and copies provided on request.

### **7 Mechanical tests**

#### **7.1 General**

**7.1.1** The requirements relevant to the type and number of tests to be carried out are given in the Sections relevant to the various applications.

Test material sufficient for the required tests and for possible re-test purposes is to be provided for each casting or batch of castings.

The test material is to have a thickness of not less than 30 mm.

The test samples are not to be detached from the casting until the specified heat treatment has been completed and they have been properly identified.

## **7.2 Individual testing**

**7.2.1** At least one test block is to be provided for each casting. Unless otherwise agreed these test blocks are to be either integrally cast or gated to the castings.

Where the casting is of complex design or where the finished mass exceeds 10 tonnes, two test samples are to be provided.

Where large castings are made from two or more casts, which are not mixed in a ladle prior to pouring, two or more test blocks are to be provided corresponding to the number of casts involved. These are to be integrally cast at locations as widely separated as possible.

## **7.3 Batch testing**

**7.3.1** A batch testing procedure may be adopted for small castings of about the same size, each of which is under 1000 kg in mass, made from one cast and heat treated in the same furnace charge.

The test block may be cut from one or more castings of the batch or, alternatively, separately cast samples may be used. When cast blocks are used, they are to be properly identified and heat treated together with the castings of the batch.

## **7.4 Preparation of test specimen**

**7.4.1** For the preparation of test specimens and relevant testing procedure, reference is made to the applicable requirements of Chapter 2.

## **7.5 Tensile test**

**7.5.1** The results of the tensile test at ambient temperature are to comply with the requirements of the appropriate Tables, or of the relevant approved specification when steels other than those specified in these Rules are accepted.

Reference is made to Sec 5, [1.7] for the properties at elevated temperatures and their verification, when required.

## **7.6 Impact test**

**7.6.1** The average value of a set of 3 tests is to comply with the average value required in the appropriate Tables, or in the approved specification when steels other than those specified in these Rules are accepted.

Only one individual value may be lower than the average value required, provided that it is not less than 70% of it.

The minimum average values for impact tests indicated in the Tables are relevant to standard specimens 10x10mm<sup>2</sup>.

## **7.7 Hardness test**

**7.7.1** Where a batch testing procedure is used, hardness tests of Brinell type may be required, at the discretion of the Surveyor, to check the homogeneity of the batch.

## **7.8 Re-test procedures**

**7.8.1** Samples for possible re-tests are to be taken as near as practicable to the specimens used for the original tests but alternatively may also be taken from another test position or sample representative of the casting or batch of castings.

Reference is made to Ch 1, Sec 1, [3.5].

For tensile re-test procedure, reference is made to Ch 2, Sec 2, [1.3].

For Charpy V-notch re-test procedure, reference is made to Ch 2, Sec 4, [1.4].

**7.8.2** At the option of the manufacturer, when a casting or batch of castings has failed to meet the test requirements, it may be reheat treated and re-submitted for acceptance tests.

# **8 Pressure test**

## **8.1 Testing conditions**

**8.1.1** Castings subject to internal pressure are to be subjected to a hydraulic pressure test in compliance with the conditions laid down in the applicable parts of the Rules.

The test pressure is to be measured by means of a suitable calibrated pressure gauge.

The test is to be performed on the casting in the finished condition and before the application of any coating which may conceal the effect of the test.

Unless otherwise agreed, the test of castings is to be carried out in the presence of the Surveyor.

A report confirming the satisfactory results of the pressure tests and indicating the relevant testing conditions is to be issued by the Manufacturer.

## 9 Visual and dimensional examination

### 9.1 Visual examination

**9.1.1** All castings are to be cleaned and adequately prepared for examination; suitable methods include pickling, caustic cleaning, wire brushing, local grinding, and shot or sand blasting.

The surfaces are not to be hammered or treated in any way which may obscure defects.

All products are to be submitted by the Manufacturer to visual examination; where applicable, this is to include the examination of internal surfaces and bore.

All castings are to be presented to the Surveyor for visual examination.

### 9.2 Verification of dimensions

**9.2.1** The verification of dimensions and tolerances is the responsibility of the Manufacturer.

Checks of dimensions for verification of compliance with the approved plans are, in general, required for important castings, to the Surveyor's satisfaction.

## 10 Non-destructive examination

### 10.1 General

**10.1.1** When required by the applicable Parts of the Rules, the approved plans, the approved procedures for welded composite components or, in specific cases, the Surveyor, appropriate non-destructive tests are to be carried out in accordance with a recognized standard and the results reported by the Manufacturer.

Reference is made to the general provisions given in Ch 1, Sec 1, [3.6].

The extent of testing and acceptance criteria are to be agreed with the Society. The IACS Recommendation No.69 is regarded as an example of an acceptable standard specifying minimum requirements.

The Manufacturer is to provide the Surveyor with a report confirming that the required examinations have been carried out without revealing significant defects; including reference of the testing standard and the agreed acceptance criteria.

### 10.2 Magnetic and liquid penetrant examination

**10.2.1** Magnetic particle or liquid penetrant examination is to be carried out when the castings are in the finished condition. Where current flow methods are used for magnetisation, particular care is to be taken to avoid damaging finished machined surfaces by contact burns from the prods.

Unless otherwise agreed, these tests are to be carried out in the presence of the Surveyor.

### 10.3 Radiographic examination

**10.3.1** Radiographic examination is to be carried out by the Manufacturer at positions as indicated on the approved plans and, in areas deemed susceptible to casting defects; welded joints and adjacent zones are also to be checked.

All radiographs are to be submitted to the Surveyor for acceptance.

### 10.4 Ultrasonic examination

**10.4.1** Ultrasonic examination is to be carried out following the final heat treatment at positions as indicated in [10.3.1].

Unless otherwise required, this examination is to be carried out by the Manufacturer but Surveyors may request to be present.

## 11 Repair by grinding

### 11.1 General requirements

**11.1.1** Defective parts of material may be removed by grinding, or by chipping and grinding or by arc-air gouging and grinding. When arc-air gouging is used, suitable preheating is to be applied when necessary due to the chemical composition and/or the dimensions of the casting.

Thermal methods of metal removal of defect shall only be allowed before the final heat treatment.

All grooves shall have a bottom radius of approximately three times the groove depth and shall be smoothly blended to the surface area with a finish equal to that of the adjacent surface.

Shallow grooves or depressions resulting from the removal of defects are not to cause appreciable reduction in the strength of the casting or affect the intended use, and the depth of defect removal is not over 15 mm or 10% of wall thickness, whichever is less and may be accepted with the agreement of the Society.

The resulting grooves or depressions are to be subsequently ground smooth and complete elimination of the defective material is to be verified by MT or PT. Small surface irregularities sealed by welding are to be treated as weld repairs.

Where castings are to be repaired, the manufacturer shall exercise controls of all repair operations regarding the repair of castings, with respect to dimensions, heat treatment, inspection and quality control.

The manufacturer is to maintain records detailing the extent and location of repairs made to each casting. The records are to be presented to the surveyor and copies provided on request.

## **12 Repair by welding**

### **12.1 General requirements**

**12.1.1** Weld repairs for C and C-Mn steel castings are classified as major or minor.

A weld repair is considered major when the depth is greater than 25% of the wall thickness or 25 mm whichever is less, or, the total weld area on a casting exceeds 0,125 m<sup>2</sup> of the casting surface noting that where a distance between two welds is less than their average width, they are to be considered as one weld.

All other weld repairs are considered minor weld repairs. Minor repairs in critical areas are to be treated as major repairs.

**12.1.2** For alloy steel castings, weld repair requires approval from the Society.

**12.1.3** Before major weld repair or repair of alloy casting is started, full details of the extent and location of the repair, the proposed welding procedure, heat treatment and subsequent inspection procedures are to be submitted for approval.

**12.1.4** Weld repair are to be carried out before the final delivery heat treatment condition. Large castings in carbon or carbon-manganese steels, all alloy steel castings, all castings for crankshafts and all steel castings when deemed necessary for major repairs are to be given a suitable preliminary heat treatment prior to welding.

**12.1.5** The excavations are to be suitably shaped to allow good access for welding. The resulting grooves are to be subsequently ground smooth and complete elimination of the defective material is to be verified by magnetic particle or liquid penetrant testing.

**12.1.6** All castings in alloy steels and all castings for crankshafts are to be suitably pre-heated prior to welding. Castings in carbon or carbon-manganese steel may also require to be pre-heated depending on their chemical composition and the dimensions and position of the weld repairs.

**12.1.7** Welding procedures are to be qualified as per Chapter 12 or recognised standard (e.g. ISO 11970:2016). Delivery condition used for welding procedure tests is to be the same as the casting to repair.

**12.1.8** The welding consumables used are to be of an appropriate composition, giving a weld deposit with mechanical properties similar and in no way inferior to those of the parent castings. Welding procedure qualification tests are to be carried out by the manufacturer to demonstrate that satisfactory mechanical properties can be obtained after final heat treatment or stress relieving heat treatment, as applicable.

**12.1.9** Welding is to be done under cover in positions free from draughts and adverse weather conditions by qualified welders with adequate supervision, in accordance with the approved welding procedure specification. As far as possible, all welding is to be carried out in the downhand (flat) position.

**12.1.10** After welding has been completed the castings are to be given either a suitable heat treatment in accordance with [6] or a stress relieving heat treatment at a temperature of not less than 550°C for C and C-Mn steel castings. For alloy steel castings, the heat treatment has to be agreed with the Society. The type of heat treatment employed will be dependent on the chemical composition of the casting and the dimensions, positions and nature of the repairs and should not affect the properties of the casting.

**12.1.11** Subject to prior agreement with the Society, consideration may be given to the omission of postweld heat treatment or to the acceptance of local stress-relieving heat treatment where the repaired area is small and machining of the casting has reached an advanced stage.

**12.1.12** On completion of heat treatment the weld repairs and adjacent material are to be ground smooth and examined by magnetic particle or liquid penetrant testing. Supplementary examination by ultrasonic or radiographic testing may also be required depending on the dimensions and nature of the original defect. Satisfactory results are to be obtained from all forms of non-destructive testing used.

**12.1.13** The manufacturer is to maintain full records detailing the extent and location of repairs made to each casting and details of weld procedures and heat treatment applied for repairs. These records are to be available to the Surveyor and copies provided on request.

## **13 Identification and marking**

### **13.1 General requirements**

**13.1.1** The Manufacturer is to adopt a system of identification which will enable all finished castings to be traced to the original cast and their manufacturing.

Before acceptance, all castings which have been tested and inspected with satisfactory results are to be marked with the following details:

- a) Manufacturer's name or trade mark
- b) Society's brand
- c) Identification mark for the grade of steel
- d) Identification number, cast number or other marking which will enable the history of the fabrication of the casting to be traced
- e) Society's marks including Society's certificate number
- f) Test pressure, where applicable.

Modified arrangements for identification and marking may be agreed with the Society in the case of small castings manufactured in large numbers.

## **14 Documentation and certification**

### **14.1 General requirements**

**14.1.1** The testing documentation indicated in Ch 1, Sec 1, [4.2.1] is to be issued and is to include all the information, as appropriate.

The ladle analysis is to include the content of refining and alloying elements as applicable.

Where applicable, the reports relevant to the non-destructive examination [10.1.1], weld repair [12] and pressure test [8.1.1] are to be enclosed with the testing documentation.

# Section 2 Castings for Hull, Offshore Structures and Welded Components in General

## 1 Requirements

### 1.1 Scope

**1.1.1** The requirements of this Section apply to steel castings intended for hull structures, offshore structures and welded components in general, where design and acceptance tests are related to mechanical properties at ambient temperature.

### 1.2 Steel grades

**1.2.1** Castings are divided into the qualities Normal and Special depending on chemical composition and mechanical properties.

The steel grades are identified by the letter G, followed by a number indicating the minimum specified tensile strength  $R_m$  (in N/mm<sup>2</sup>) and by the symbol 1 for Normal quality or 2 for Special quality.

**1.2.2** Limits on the specified minimum tensile strength and quality to be used for hull structures are given in the Society's Rules for the Classification of Steel Ships Part B and/or required by the Society on the relevant approved plans.

In particular, the use of the grades G480 and G520 may be restricted to quality 2 and to specific conditions.

**1.2.3** Where it is proposed to use alloy steels, the specification of the steel grade (chemical composition, heat treatment and mechanical properties) is to be submitted for approval.

### 1.3 Manufacture

#### 1.3.1 Approval

Castings having a mass above 1000 kg are to be manufactured at works which are approved by the Society. Provisions are given in Sec 1, [3].

### 1.4 Chemical composition

**1.4.1** All castings are to be made from killed steel.

**1.4.2** Suitable grain refining elements such as aluminium, niobium or vanadium are to be added to Quality 2 steels. The content of such elements is to be reported.

**1.4.3** The chemical composition on ladle analysis of carbon or carbon-manganese steels is to comply with the limits given in Tab 1 or, where applicable the requirements of the approved specification.

**1.4.4** The chemical composition on ladle analysis is to comply with the approved specification for alloy steels.

**1.4.5** Maximum carbon equivalent (Ceq) value specified for castings for offshore structures and components is to be agreed with the Society.

### 1.5 Heat treatment

**1.5.1** Carbon or carbon-manganese steel castings are to be supplied in one of the following conditions:

a) Carbon and carbon-manganese steels:

- fully annealed
- normalised
- normalised and tempered
- quenched and tempered

b) Alloy steels:

- normalised
- normalised and tempered
- quenched and tempered.

For all types of steel the tempering temperature is to be less than 550°C.

The delivery condition shall meet the design and application requirements. It is the manufacturers responsibility to select the appropriate heat treatment method to obtain the required mechanical properties.



**Table 1 : Chemical composition**

Steel type	C (max)	Si (max)	Mn	S (max)	P (max)	Residual elements (max.)				Total residuals (max.)
						Cu	Cr	Ni	Mo	
C, C-Mn	0,23	0,60	0,50 - 1,60	0,035	0,035	0,30	0,30	0,40	0,15	0,80

**1.6 Mechanical properties**

**1.6.1** Tab 2 gives the minimum requirements for yield stress, elongation and reduction of area corresponding to different strength levels. Where it is proposed to use a steel with a specified minimum tensile strength intermediate to those given, corresponding minimum values for the other tensile properties may be obtained by interpolation.

Charpy V-notch impact test requirements applicable to castings for offshore structures and components are to be agreed with the Society in accordance with the Society’s Offshore Rules.

**Table 2 : Mechanical properties**

Steel type	Specified minimum tensile strength <b>(1)</b> (N/mm <sup>2</sup> )	Yield stress (N/mm <sup>2</sup> ) min.	Elongation on 5,65 √S <sub>0</sub> (%) min.	Reduction of area (%) min.	Charpy V-notch impact test <b>(2)</b>	
					Test temperature (C°)	Minimum average energy (J)
C, C-Mn	400	200	25	40	0	27
	440	220	22	30		
	480	240	20	27		
	520	260	18	25		
	560	300	15	20		
	600	320	13	20		
Alloy	550	355	18	30	0	27
	600	400	16	30		
	650	450	14	30		
	700	540	12	28		

**(1)** A tensile strength range of 150 N/mm<sup>2</sup> may additionally be specified.  
**(2)** Special consideration may be given to alternative requirements for Charpy V-notch impact test, depending on design and application, and subject to agreement by Society.

**1.7 Mechanical tests**

**1.7.1** The number of test samples required is given in Sec 1, [7.2.1] for individual testing and in Sec 1, [7.3.1] for batch testing. The test specimens for 1 tensile and 3 Charpy V-notch impact tests are to be taken from each test sample.

**1.8 Non-destructive examination**

**1.8.1** Castings intended for the construction of sternframes, poop structure, rudders and propeller shaft supports are to be non-destructively tested by ultrasonic and magnetic methods.

Other castings are to be examined by non-destructive test methods as required by the Society on the approved plans or, in specific cases, by the Surveyor.

# Section 3 Castings for Machinery and Non-Welded Components in General

## 1 Requirements

### 1.1 Scope

**1.1.1** The requirements of this Section apply to carbon or carbon-manganese steel castings, intended for use in the construction of machinery and non-welded components in general.

Provisions for castings for anchors are given in Ch 10, Sec 1.

### 1.2 Steel grades

**1.2.1** Castings are divided into the qualities Normal and Special depending on chemical composition and mechanical properties.

The steel grades are identified by the letter G, followed by a number indicating the minimum specified tensile strength  $R_m$  (in N/mm<sup>2</sup>) and by the symbol 1 for Normal quality or 2 for Special quality.

**1.2.2** Where it is proposed to use alloy steels, the specification of the steel grade (chemical composition, heat treatment and mechanical properties) is to be submitted for approval.

### 1.3 Manufacture

#### 1.3.1 Approval

Castings having a mass above 1000kg are to be manufactured at works which are approved by the Society. Provisions are given in Sec 1, [3].

### 1.4 Chemical composition

**1.4.1** All castings are to be made from killed steel.

**1.4.2** Suitable grain refining elements such as aluminium, niobium or vanadium are to be added to Quality 2 steels. The content of such elements is to be reported.

**1.4.3** The chemical composition on ladle analysis of carbon or carbon-manganese steels is to comply with the limits given in Tab 1 or, where applicable the requirements of the approved specification.

### 1.5 Heat treatment

**1.5.1** Castings are to be supplied in one of the following conditions:

a) Carbon and carbon-manganese steels:

- fully annealed
- normalised
- normalised and tempered
- quenched and tempered

b) Alloy steels:

- normalised
- normalised and tempered
- quenched and tempered.

For all types of steel the tempering temperature is to be less than 550°C.

The delivery condition shall meet the design and application requirements. It is the manufacturers responsibility to select the appropriate heat treatment method to obtain the required mechanical properties.

Castings for components such as engine bedplates, turbines and other castings in general, where dimensional stability and low internal stress level are a concern, are to be given a stress relief heat treatment. This is to be carried out at a temperature of not less than 550°C and then cooled in the furnace to 300°C or lower. When the full annealing or the tempering of the normalised and tempered steels is followed by furnace cooling to 300°C or lower, the stress relief treatment is not required.

**Table 1 : Chemical composition**

Steel type	C (max.)	Si (max.)	Mn	S (max.)	P (max.)	Residual elements (max.) (1)				Total residuals (max.)
						Cu	Cr	Ni	Mo	
C, C-Mn	0,40	0,60	0,50 - 1,60	0,035	0,035	0,30	0,30	0,40	0,15	0,80
Alloy	0,45	0,60	0,50 - 1,60	0,030	0,035	0,30	0,40	0,40	0,15	

(1) At least one of the elements shall comply with the minimum content.

**1.6 Mechanical properties**

1.6.1 Tab 2 gives the minimum requirements for yield stress, elongation and reduction of area corresponding to different strength levels. Where it is proposed to use a steel with a specified minimum tensile strength intermediate to those given, corresponding minimum values for the other tensile properties may be obtained by interpolation.

Charpy V-notch impact test requirements applicable to castings for offshore structures and components are to be agreed with the Society in accordance with the Society’s Offshore Rules.

**Table 2 : Mechanical properties**

Steel type	Specified minimum tensile strength (1) (N/mm <sup>2</sup> )	Yield stress (N/mm <sup>2</sup> ) min.	Elongation on $5,65 \sqrt{S_0}$ (%) min.	Reduction of area (%) min.	Charpy V-notch impact test (2)	
					Test temperature (C°)	Minimum average energy (J)
C, C-Mn	400	200	25	40	AT (3)	27
	440	220	22	30		
	480	240	20	27		
	520	260	18	25		
	560	300	15	20		
	600	320	13	20		
Alloy	550	340	16	35	AT (3)	27
	600	400	16	35		
	650	450	14	32		
	700	540	12	28		

- (1) A tensile strength range of 150 N/mm<sup>2</sup> may additionally be specified.  
 (2) Special consideration may be given to alternative requirements for Charpy V-notch impact test, depending on design and application, and subject to agreement by Society.  
 (3) AT refers to Ambient Temperature (i.e. 23°C±5°C), which is specified in ISO 148-1:2016

**1.7 Mechanical tests**

1.7.1 The number of test samples required is given in Sec 1, [7.2.1] for individual testing and in Sec 1, [7.3.1] for batch testing. The test specimens for 1 tensile test is to be taken from each test sample.

**1.8 Non-destructive examination**

1.8.1 Ultrasonic examination is to be carried out on the following items:

- a) piston crowns and cylinder covers
- b) parts of engine bedplates
- c) turbine casings
- d) rudder components.

1.8.2 A magnetic particle examination is to be carried out for the following items:

- a) piston crowns and cylinder covers for engines having a bore size greater than 400 mm
- b) parts of engine bedplates
- c) turbine casings
- d) rudder components.

The parts to be examined and the test procedures are to be agreed with the Surveyor.

Other castings are to be examined by non-destructive test methods as required by the Society on the approved plans, or, in specific cases, by the Surveyor.

# Section 4 Castings for Crankshafts

## 1 Requirements

### 1.1 Scope

**1.1.1** The requirements of this Section apply to carbon or carbon-manganese steel castings intended for the construction of semi-built and fully built crankshafts.

### 1.2 Steel grades

**1.2.1** As required in the Society's Rules for the Classification of Steel Ships, NR467, Pt C, Ch 1, Sec 2, the steel grade specification (chemical composition, heat treatment and mechanical properties) is to be submitted for approval when the engine type approval is processed.

### 1.3 Manufacture

#### 1.3.1 Approval

Castings for crankshafts are to be manufactured at works which are approved by the Society. Provisions are given in Sec 1, [3].

### 1.4 Chemical composition

**1.4.1** All castings are to be made from killed and fine grain treated steel.

**1.4.2** The chemical composition on ladle analysis is to comply with the requirements of the approved specification.

### 1.5 Heat treatment

**1.5.1** Castings are to be supplied in the condition stated in the approved specification.

Castings in carbon or carbon-manganese steels are generally supplied in one of the following conditions:

- fully annealed and cooled in the furnace to 300°C or less
- normalised and tempered to a temperature of not less than 550°C, then cooled in the furnace to 300°C or less.

### 1.6 Mechanical properties

**1.6.1** The mechanical properties are to comply with the requirements of the approved specification.

### 1.7 Mechanical tests

**1.7.1** The number and position of the specimens for mechanical tests are agreed at the time of approval of the manufacturing process.

### 1.8 Non-destructive examinations

**1.8.1** All the surfaces of the casting in the finished condition are to be tested by magnetic particle.

Where applicable this test is to be performed on all flame cut surfaces not subsequently machined as well.

All the castings are to be tested by ultrasonics.

The procedures for ultrasonics examination as well as acceptance criteria are to comply with the requirements of the engine manufacturer and are to be agreed with the Society.

# Section 5 Castings for Boilers, Pressure Vessels and Systems

## 1 Requirements

### 1.1 Scope

**1.1.1** The requirements of this Section apply to steel castings intended for the welded construction of boilers, pressure vessels, plants and piping systems in general, operating at temperatures not lower than 0°C.

**1.1.2** Castings intended for vessels and systems operating at temperatures lower than 0°C are to comply with the applicable requirements of Sec 6 for applications involving the storage and transport of liquefied gases and those specified in the Society's Rules for the Classification of Steel Ships (NR467) as appropriate.

### 1.2 Steel grades

**1.2.1** The requirements apply to carbon, carbon-manganese or low alloy steels (Mo and Cr-Mo steels).

The C and C-Mn steels are classed into three groups and are identified by the specified minimum tensile strength  $R_m$  (in N/mm<sup>2</sup>) 400, 440, 480, followed by the letter P.

Carbon or carbon-manganese steels having a minimum specified tensile strength  $R_m$  greater than the above but without exceeding 520 N/mm<sup>2</sup> may be accepted, at the discretion of the Society, on the basis of their detailed specification.

**1.2.2** Low alloy steels are designated according to the chemical composition into the grades 0,3Mo - 1Cr0,5Mo - 2,25Cr1Mo - 0,5Cr0,5Mo0,25V.

The figures mean the nominal percentage content of the main alloying elements.

### 1.3 Manufacture

#### 1.3.1 Approval

Castings having a mass above 1000kg are to be manufactured at works which are approved by the Society. Provisions are given in Sec 1, [3].

### 1.4 Chemical composition

**1.4.1** The chemical composition on ladle analysis is to comply with the requirements specified in Tab 1 or the approved specification as applicable.

**Table 1 : Chemical composition**

Steel grade	Chemical composition (%) (1)								
	C	Mn	Si	P max	S max	Cr	Mo	V	Ni max
400 P	≤ 0,23	0,50-1,20	≤ 0,60	0,035	0,035	≤ 0,30	≤ 0,15	–	–
440 P	≤ 0,23	0,50-1,20	≤ 0,60	0,035	0,035	≤ 0,30	≤ 0,15	–	0,40 (1)
480 P	≤ 0,25	0,60-1,60	≤ 0,60	0,035	0,035	≤ 0,30	≤ 0,15	–	0,40 (1)
0,5Mo	0,15-0,23	0,50-1,00	0,30-0,60	0,035	0,035	≤ 0,30	0,40-0,60	–	0,40
1Cr0,5Mo	0,10-0,20	0,50-1,00	0,30-0,60	0,035	0,035	1,00-1,50	0,45-0,65	–	0,40
2,25Cr1Mo	0,13-0,20	0,50-1,00	0,30-0,60	0,035	0,035	2,00-2,50	0,90-1,20	–	0,40
0,5Cr0,5Mo0,25V	0,10-0,18	0,40-0,80	0,30-0,60	0,035	0,035	0,70-1,10	0,40-0,60	0,22-0,30	0,40

(1) With the exception of refining elements, additional alloying elements are to be submitted for consideration and approval.  
Residual elements are not to exceed the following limits (%):  
for C and C-Mn steels: Cu ≤ 0,30; total: Ni + Cu + Cr + Mo ≤ 0,80  
for alloy steels: Cu ≤ 0,30

**1.5 Heat treatment**

1.5.1 Castings are to be supplied in one of the following conditions:

- fully annealed
- normalised
- normalised and tempered
- quenched and tempered.

The tempering temperature is to be of not less than 550°C.

**1.6 Mechanical properties**

1.6.1 The mechanical properties are to comply with the requirements given in Tab 2 or the approved specification, as applicable.

**Table 2 : Mechanical properties**

Steel grade	Yield stress $R_{eH}$ (N/mm <sup>2</sup> ) min.	Tensile strength (N/mm <sup>2</sup> )	Elongation $A_5$ (%) min.	Reduction of area Z (%) min.	Average impact energy (J) at + 20°C
					V-notch
400 P	200	400 - 550	25	40	27
440 P	230	440 - 590	22	38	27
480 P	250	480 - 630	20	30	27
0,5Mo	245	450 - 600	21	35	25
1Cr 0,5Mo	290	480 - 630	18	35	25
2,25Cr 1Mo	280	500 - 650	18	35	25
0,5Cr 0,5Mo 0,25V	310	500 - 650	17	35	16

**1.7 Mechanical properties at elevated temperature**

1.7.1 The values for the 0,2% proof stress ( $R_{p0,2}$ ), at temperatures of 150°C and higher, are given in Tab 3.

The above values are for design purposes only. Their verification is generally not required for material certification.

1.7.2 Where, however, a verification of the properties at elevated temperature (above 200°C) is required, the following procedure applies, unless otherwise agreed:

- a tensile test to verify the yield stress is to be performed at an agreed temperature (in relation to the design temperature) rounded to the nearest multiple of 50°C
- the test is to be carried out on samples properly taken from the castings selected
- the test samples are to be heat treated, as required, together with the casting they represent
- the test procedure is to be in compliance with the relevant requirements of Ch 2, Sec 2, [1.1] and Ch 2, Sec 2, [1.2.5]
- the result of the test is to comply with the yield stress value specified at the test temperature concerned.

1.7.3 Where figures higher than those shown in Tab 3 and in accordance with recognised standards are proposed by the steel Manufacturer, their verification is required and procedures similar to those detailed in Ch 3, Sec 6, [1.7.2] are to be followed in agreement with the Society.

1.7.4 The values of the estimated average stress to rupture in 100 000 hours, for design purposes only, are given in Ch 3, Sec 6, Tab 6.

**Table 3 : Minimum proof stress ( $R_{p0,2}$ ) values at elevated temperatures**

Steel grade	$R_{p0,2}$ (N/mm <sup>2</sup> ) at a temperature (°C) of									
	150	200	250	300	350	400	450	500	550	600
400 P										
440 P	210	200	185	160	155	150	135			
480 P										
0,5Mo	235	225	205	185	175	170	155	145	135	125
1Cr 0,5Mo		200		195		185		160		115
2,25Cr 1Mo	310	305	295	290	280	270	255	240	210	180
0,5Cr 0,5Mo 0,25V		245		300		215		195		145

**Note 1:** The values at  $R_{p0,2}$  for temperatures  $\leq 200^\circ\text{C}$  are for guidance only.

### 1.8 Mechanical tests

**1.8.1** The number of test samples required is given in Sec 1, [7.2.1] for individual testing and in Sec 1, [7.3.1] for batch testing. The test specimens for 1 tensile and 3 Charpy V-notch impact tests are to be taken from each test sample.

### 1.9 Non-destructive examination

**1.9.1** The castings are to be examined by means of the non-destructive tests required by the applicable Rules or by the Society on the approved plans; tests may also be required in individual cases at the discretion of the Surveyor.

# Section 6 Ferritic Steel Castings for Low Temperature Service

## 1 Requirements

### 1.1 Scope

**1.1.1** The requirements of this Section apply to ferritic steel castings intended for welded structural use as in the construction of structures, vessels, plants and piping systems for low temperature service or when, irrespective of the service conditions, they are required to satisfy specified impact properties at temperatures lower than 0°C.

**1.1.2** In the case of applications involving the storage and transport of liquefied gases or fluids at low temperature, reference is to be made to Society's Rules for the Classification of Steel Ships, NR467, Part D, Chapter 9, and, to the International Code for the Construction and Equipment of Ships Carrying Liquefied Gases in Bulk (IGC Code).

For gas fuelled ships, reference is to be made to Society Rule Note NR529, and, to the International Code of Safety for Ships using Gases or other Low-flash point (IGF Code).

### 1.2 Steel grades

**1.2.1** The requirements apply to carbon-manganese or nickel steels specified in [1.2.2] and [1.2.3].

Where it is proposed to use alternative steel grade, the specification (chemical composition, heat treatment and mechanical properties) is to be submitted for approval.

**1.2.2** Carbon-manganese steels are classed into three groups indicated by the specified minimum tensile strength  $R_m$ : 400, 440 or 480 N/mm<sup>2</sup>.

Each group is further subdivided into three grades: LD, LE and LF, based on the impact test temperature specified at -20°C, -40°C and -60°C, respectively.

**1.2.3** Ni steels are designated according to the chemical composition into the grades 2,5Ni, 3,5Ni and 9,0Ni. The figures mean the Ni nominal percentage content.

### 1.3 Manufacture

#### 1.3.1 Approval

Castings having a mass above 1000kg are to be manufactured at works which are approved by the Society. Provisions are given in Sec 1, [3].

### 1.4 Chemical composition

**1.4.1** The chemical composition on ladle analysis is to comply with the requirements specified in Tab 1 and Tab 2 or the approved specification as applicable.

**Table 1 : Carbon and carbon manganese steels - Chemical composition**

Steel grade	Chemical composition (%) (1)							
	C max	Mn	Si	P max	S max	Ni	Al tot	Others
400 LD-LE-LF	0,23	0,50 - 1,20	0,30 - 0,60	0,035	0,035	≤ 0,80	≥ 0,020	Cr ≤ 0,25
440 LD-LE-LF	0,23	0,60 - 1,30	0,30 - 0,60	0,035	0,035	≤ 0,80	≥ 0,020	Cu ≤ 0,30
480 LD-LE-LF	0,25	0,60 - 1,30	0,30 - 0,60	0,035	0,035	≤ 0,80	≥ 0,020	Mo ≤ 0,15

(1) With the exception of refining elements, additional alloying elements are to be submitted for consideration and approval.

**Table 2 : Nickel steels - Chemical composition**

Steel grade	Chemical composition (%) (1)						
	C max	Mn	Si	P max	S max	Ni	Others
2,5Ni	0,16	0,50 - 0,80	0,30 - 0,60	0,035	0,035	2,00 - 3,00	Cr ≤ 0,25
3,5Ni	0,14	0,50 - 0,80	0,30 - 0,60	0,035	0,035	3,00 - 4,00	Cu ≤ 0,30
9,0 Ni	0,12	0,50 - 0,80	0,30 - 0,60	0,035	0,035	8,50 - 9,50	Mo ≤ 0,15

(1) With the exception of refining elements, additional alloying elements are to be submitted for consideration and approval.



**1.5 Heat treatment**

1.5.1 Castings are to be supplied in one of the following conditions:

- fully annealed
- normalised
- normalised and tempered at a temperature of not less than 550°C
- quenched and tempered.

**1.6 Mechanical properties**

1.6.1 The mechanical properties are to comply with the requirements given in Tab 3 and Tab 4 or the approved specification, as applicable.

**Table 3 : Carbon and carbon manganese steels - Mechanical properties**

Steel grade	Yield stress $R_{eH}$ (N/mm <sup>2</sup> ) min.	Tensile strength $R_m$ (N/mm <sup>2</sup> )	Elongation $A_5$ (%) min.	Reduction of area Z (%) min.	Average impact energy (J) min.	
					Test temp (°C)	KV
400 LD	200	400 - 550	25	40	- 20	27
400 LE					- 40	
400 LF					- 60	
440 LD	230	440 - 590	22	35	- 20	27
440 LE					- 40	
440 LF					- 60	
480 LD	250	480 - 630	20	30	- 20	27
480 LE					- 40	
480 LF					- 60	

**Table 4 : Nickel steels - Mechanical properties**

Steel grade	Yield stress $R_{eH}$ (N/mm <sup>2</sup> ) min.	Tensile strength $R_m$ (N/mm <sup>2</sup> )	Elongation $A_5$ (%) min.	Reduction of area Z (%) min.	Average impact energy (J) min.	
					Test temp (°C)	KV
2,5Ni	275	490 - 640	20	35	- 70	34
3,5 Ni	275	490 - 640	20	35	- 95	34
9,0 Ni	490	640 - 790	18	30	- 196	41

**1.7 Mechanical tests**

1.7.1 The number of test samples required is given in Sec 1, [7.2.1] for individual testing and in Sec 1, [7.3.1] for batch testing. The test specimens for 1 tensile and 3 Charpy V-notch impact tests are to be taken from each test sample.

**1.8 Non-destructive examination**

1.8.1 The castings are to be examined by means of the non-destructive tests required by the applicable Rules or by the Society on the approved plans; tests may also be required in individual cases at the discretion of the Surveyor.

# Section 7 Stainless Steel Castings

## 1 Requirements

### 1.1 Scope

**1.1.1** The requirements of this Section apply to stainless steel castings intended for construction of cargo tanks, pressure vessels and piping fittings for chemicals and/or low temperature applications.

**1.1.2** In the case of applications involving the storage and transport of liquefied gases or fluids at low temperature, reference is made to Society's Rules for the Classification of Steel Ships, NR467, Part D, Chapter 9, and, to the International Code for the Construction and Equipment of Ships Carrying Liquefied Gases in Bulk (IGC Code).

For gas fuelled ships, reference is to be made to Society Rule Note NR529, and, to the International Code of Safety for Ships using Gases or other Low-flash point (IGF Code).

### 1.2 Steel grades

**1.2.1** The requirements apply to austenitic Cr-Ni steels.

Note 1: The steels are designated according to the corresponding AISI type.

Where it is proposed to use alternative steel grade, the specification (chemical composition, heat treatment and mechanical properties) is to be submitted for approval.

### 1.3 Manufacture

#### 1.3.1 Approval

Castings having a mass above 1000kg are to be manufactured at works which are approved by the Society. Provisions are given in Sec 1, [3].

### 1.4 Chemical composition

**1.4.1** The chemical composition on ladle analysis is to comply with the requirements specified in Tab 1 or the approved specification as applicable.

### 1.5 Heat treatment

**1.5.1** Castings are to be supplied in solution treated condition.

### 1.6 Mechanical properties

**1.6.1** The mechanical properties are to comply with the requirements given in Tab 2 or the approved specification, as applicable.

**Table 1 : Chemical composition**

AISI grade designation	Chemical composition (%)								
	C max	Mn max	Si max	P max	S max	Cr	Ni	Mo	Others
304L	0,030	2,0	1,5	0,040	0,030	17,0 - 21,0	8,0 - 12,0	–	
304	0,080	2,0	1,5	0,040	0,030	17,0 - 21,0	8,0 - 12,0	–	
316L	0,030	2,0	1,5	0,040	0,030	17,0 - 21,0	9,0 - 13,0	2,0 - 3,0	
316	0,080	2,0	1,5	0,040	0,030	17,0 - 21,0	9,0 - 13,0	2,0 - 3,0	
347	0,080	2,0	1,5	0,040	0,030	17,0 - 21,0	9,0 - 13,0	–	10 x C ≤ Nb ≤ 0,80

**Table 2 : Mechanical properties**

AISI grade designation	Yield strength $R_{p1,0}$ (N/mm <sup>2</sup> ) min.	Tensile strength $R_m$ (N/mm <sup>2</sup> ) min.	Elong. $A_5$ (%) min.	Reduction of area Z (%) min.	Average impact energy min. KV at – 196°C
304 L	215	430	26	40	41
304	220	480	26	40	41
316L	215	430	26	40	41
316	240	480	26	40	41
347	215	480	22	35	41

### 1.7 Mechanical tests

**1.7.1** The number of test samples required is given in Sec 1, [7.2.1] for individual testing and in Sec 1, [7.3.1] for batch testing. The test specimens for 1 tensile and 3 Charpy V-notch impact tests are to be taken from each test sample.

Unless otherwise agreed, impact tests on the austenitic grades are to be performed for design temperature below  $-105^{\circ}\text{C}$  and are to be carried out at  $-196^{\circ}\text{C}$ .

In the case of applications involving the storage and transport of liquified gases (as per Sec 1, [1.4.1]), the following applies:

- impact tests are required for castings in steel grades 316 and 316L (which contain molybdenum) whatever is the design temperature and are to be carried out at  $-196^{\circ}\text{C}$ . A reduction of the tests may be granted for design temperatures above  $-60^{\circ}\text{C}$ , subject to the agreement of the Society.
- impact tests are required for castings in steel grades 304, 304L, 321 and 347 when the design temperature is below  $-60^{\circ}\text{C}$  and are to be carried out at  $-196^{\circ}\text{C}$ .

### 1.8 Non-destructive examination

**1.8.1** Unless otherwise agreed, castings are to be tested by liquid penetrant and/or ultrasonics, as required, depending on the application.

### 1.9 Corrosion tests

**1.9.1** For castings intended for chemicals, the corrosion tests, ASTM A262 Practice E (Copper-copper sulphate sulphuric) or ASTM A262 Practice C (Nitric acid test) as appropriate, may be required to be carried out on one piece per batch.

Tests in accordance with other recognised standards are subject to the agreement of the Society.

**1.9.2** These tests are strictly conventional and do not aim at providing data on the effective resistance of the steel to the possible corrosion due to the chemicals carried in actual service conditions.

# Section 8 Stainless Steel Castings for Propellers

## 1 Requirements

### 1.1 Scope

**1.1.1** The requirements of this Section are applicable to the manufacture, inspection and repair procedures of new cast stainless steel propellers, blades and bosses.

**1.1.2** These requirements may also be applied for the repair and inspection of propellers which become damaged during service.

### 1.2 Manufacture

#### 1.2.1 Approval

Castings propeller are to be manufactured at works which are approved by the Society. Provisions are given in Sec 1, [3].

### 1.3 Quality of castings

**1.3.1** All castings are to be free from surface or internal defects, such as cracks, hot tears or other imperfections, which would be prejudicial to their proper application in service. Minor casting defects which may still be visible after machining, such as small cold shots and scabs, are to be trimmed off by the Manufacturer in accordance with [1.12].

### 1.4 Chemical composition

**1.4.1** Typical cast steel propeller alloys are grouped into four types depending on their chemical composition as given in Tab 1. The chemical composition is to comply with the requirements of Tab 1 or the approved specification, as appropriate.

### 1.5 Heat treatment

**1.5.1** Castings made of martensitic stainless steel grades are to be austenitized and tempered. Castings made of austenitic stainless steel grades are to be solution treated.

### 1.6 Mechanical properties

**1.6.1** The mechanical properties are to comply with the values given in Tab 2 or the approved specification, as appropriate.

**Table 1 : Typical chemical composition for steel propeller castings**

Alloy type	C max. (%)	Mn max. (%)	Cr (%)	Mo (1) max. (%)	Ni (%)
Martensitic (12Cr 1Ni)	0,15	2,0	11,5 - 17,0	0,5	max. 2,0
Martensitic (13Cr 4Ni)	0,06	2,0	11,5 - 17,0	1,0	3,5 - 5,0
Martensitic (16Cr 5Ni)	0,06	2,0	15,0 - 17,5	1,5	3,5 - 6,0
Austenitic (19Cr 11Ni)	0,12	1,6	16,0 - 21,0	4,0	8,0 - 13,0

(1) Minimum values are to be in accordance with recognised national or international standards.

**Table 2 : Mechanical properties for steel propeller castings**

Alloy type	Proof stress $R_{p0,2}$ min. (N/mm <sup>2</sup> )	Tensile strength $R_m$ min. (N/mm <sup>2</sup> )	Elongation A5 min. (%)	Reduction of area Z min. (%)	Charpy V-notch (1) Energy min. (J)
12Cr 1Ni	440	590	15	30	20
13Cr 4Ni	550	750	15	35	30
16Cr 5Ni	540	760	15	35	30
19Cr 11Ni	180 (2)	440	30	40	–

(1) Tests to be made at 0°C for general service and at –10°C when intended for ships with ice class notation.  
(2)  $R_{p1,0}$  value is 205 N/mm<sup>2</sup>.

## 1.7 Mechanical tests

**1.7.1** The test samples are to be cast integral with the casting represented. The test samples are to be detached from the casting after completion of the final heat treatment and by non-thermal procedures.

**1.7.2** One set of tests is to be made on material representing each casting.

**1.7.3** As an alternative to [1.7.1], where a number of small propellers of about the same size, and less than one meter in diameter, are made from one cast and heat treated in the same furnace charge, a batch testing procedure may be adopted using separately cast test samples of suitable dimensions. At least one set of tests is to be made for each multiple of five castings in the batch.

## 1.8 Definition of skew, severity zones

**1.8.1** Refer to Ch 8, Sec 3, [1.8].

## 1.9 Visual and dimensional examination

**1.9.1** All finished castings are to be 100% visually inspected by the manufacturer.

A general visual examination is to be carried out by the Surveyor.

**1.9.2** The dimensions are the responsibility of the manufacturer and the report on the dimensional inspection is to be handed over to the Surveyor, who may require checks to be made in his presence.

**1.9.3** Static balancing is to be carried out on all propellers. Dynamic balancing is required for propellers running above 500 rpm.

## 1.10 Non-destructive testing

### 1.10.1 Liquid penetrant examination

Liquid penetrant testing procedure is to be submitted to the Society and is to be in accordance with ISO 3452-1:2013 or a recognised standard. The acceptance criteria are specified in [1.11].

The severity zone A is to be subjected to a liquid penetrant testing in the presence of the Surveyor.

In zones B and C the liquid penetrant testing is to be performed by the manufacturer and may be witnessed by the Surveyor upon his request.

If repairs have been made either by grinding, straightening or by welding the repaired areas are additionally to be subjected to the liquid penetrant testing independent of their location and/or severity zone.

### 1.10.2 Magnetic particle testing

Magnetic particle testing may be used in lieu of liquid penetrant testing for examination of martensitic stainless steels castings.

Magnetic particle testing procedure is to be submitted to the Society and is to be in accordance with ISO 9934-1:2016 or a recognised standard.

### 1.10.3 Radiographic and ultrasonic examination

When required by the Society or when deemed necessary by the manufacturer, further non-destructive testing (e.g. radiographic and/or ultrasonic testing) are to be carried out.

The acceptance criteria or applied quality levels are to be agreed between the manufacturer and the Society in accordance with a recognised standard.

## 1.11 Acceptance criteria for liquid penetrant testing

### 1.11.1 Definitions

The following definitions relevant to liquid penetrant indications apply:

- Indication:

In the liquid penetrant examination an indication is the presence of detectable bleed-out of the penetrant liquid from the material discontinuities appearing at least 10 minutes after the developer has been applied.

- Relevant indication:

Only indications which have any dimension greater than 1,5 mm shall be considered relevant for the categorization of indications.

- Non-linear indication:

An indication with the largest dimension less than three times its smallest dimension.

- Linear indication:

An indication with the largest dimension three or more times its smallest dimension.

- Aligned indication:
  - Non-linear indications form an alignment when the distance between indications is less than 2 mm and at least three indications are aligned. An alignment of indications is considered to be unique indication and its length is equal to the overall length of the alignment.
  - Linear indications form an alignment when the distance between two indications is smaller than the length of the longest indication.

Illustration of liquid penetrant examination is given Ch 8, Sec 3, Fig 7.

**1.11.2 Acceptance standard**

The surface to be inspected is to be divided into reference areas of 100cm<sup>2</sup>. Each reference area may be square or rectangular with the major dimension not exceeding 250 mm. The indications detected are, with respect to their size and number, not to exceed the value given in Tab 3. The area shall be taken in the most unfavourable location relative to the indication being evaluated.

**Table 3 : Allowable number and size of relevant indications in a reference area of 100 cm<sup>2</sup>, depending on severity zones**

Severity zones	Max. total number of indications	Type of indication	Max. number of each type (1) (2)	Max. acceptable value for “ℓ” of indications (mm)
A	7	non-linear	5	4
		linear	2	3
		aligned	2	3
B	14	non-linear	10	6
		linear	4	6
		aligned	4	6
C	20	non-linear	14	8
		linear	6	6
		aligned	6	6

(1) Singular non-linear indications less than 2 mm for zone A and less than 3 mm for the other zones are not considered relevant.  
 (2) The total number of non-linear indications may be increased to the maximum total number, or part thereof, represented by the absence of linear/aligned indications.

**1.12 Repair of defects**

**1.12.1** Reference is made to Sec 1, [11] Sec 1, [12].

**1.12.2 Repair procedures**

Indications exceeding the acceptance standard of Ch 8, Sec 3, Tab 3, cracks, shrinkage cavities, sand, slag and other non-metallic inclusions, blow holes and other discontinuities which may impair the safe service of the propeller are defined as defects and must be repaired.

In general the repairs shall be carried out by mechanical means, e. g. by grinding, chipping or milling. Welding may be applied subject to the agreement of the Society if the relevant requirements detailed hereafter are satisfied.

After milling or chipping, grinding is to be applied for such defects which are not to be welded. Grinding is to be carried out in such a manner that the contour of the ground depression is as smooth as possible. Complete elimination of the defective material is to be verified by liquid penetrant testing.

Localised pores on the end face or bore of a propeller boss, which themselves do not affect the strength of the casting, can be filled with a suitable plastic filler after the appropriate preparation of the defective area. The foundry is to keep records and details of all castings which have been rectified.

**1.12.3 Repair of defects in zone A**

In zone A, repair welding will generally not be allowed unless specially approved by the Society.

In some cases the propeller designer may submit technical documentation to propose a modified zone A based on detailed hydrodynamic load and stress analysis for consideration by the Society.

Grinding can be carried out to an extent which maintains the blade thickness of the approved drawings.

The possible repair of defects which are deeper than those referred to above is to be considered by the Society.

**1.12.4 Repair of defects in zone B**

Defects that are not deeper than  $dB = (t / 40)$  mm (t is the minimum local thickness in mm according to the Rules) or 2 mm, whichever is greatest, below minimum local thickness according to the Rules should be removed by grinding. Those defects that are deepest than allowable for removal by grinding may be repaired by welding.

**1.12.5 Repair of defects in zone C**

In zone C, repair welds are generally permitted.

**1.13 Weld repair**

**1.13.1** All weld repairs are to be documented by means of sketches or photographs showing the location and major dimensions of the grooves prepared for welding. Weld repairs are to be undertaken only when they are considered to be necessary and have prior agreement of the Surveyor.

**1.13.2** Before welding is started, the company concerned shall prepare and submit to the Society a detailed welding procedure specification covering the weld preparation, welding position, welding parameter, welding consumables, preheating and post weld heat treatment and inspection procedures.

All weld repairs are to be carried out in accordance with qualified procedures, and, by welders who are qualified to a recognized standard.

Welding Procedure Qualification Tests are to be carried out in accordance with Ch 12, Sec 4, [6] and witnessed by the Surveyor.

**1.13.3** Areas which are prepared for welding are to be liquid penetrant tested and independent of their location always to be assessed in accordance with criteria for zone A.

**1.13.4** Welding of areas less than five square centimeters is to be avoided.

**1.13.5** For new propellers, the area of any single repair and the maximum total area in any zone or region are generally to be kept within the following limits, where S is the blade surface:

- a) Zone A:  
not generally permitted
- b) Zone B and C, single:  
0,006S or 60 cm<sup>2</sup>, whichever is the greater
- c) Zone B (leading edge), total:  
0,008S or 100 cm<sup>2</sup>, whichever is the greater
- d) Zone B+C, total:  
0,02S or 20 cm<sup>2</sup>, whichever is the greater
- e) Other zones, total for each zone:  
0,05S or 50 cm<sup>2</sup>, whichever is the greater.  
Other zones means in particular the following zones:
  - for integrally cast propellers:
    - within the bore
    - outer surfaces of the boss to the start of the fillet radius
    - forward and aft end faces of the boss.
  - for separately cast propeller blades:
    - surfaces of the flange to the start of the fillet radius.

**1.13.6** Welding is to be done under cover in conditions free from draughts and adverse weather.

**1.13.7** Metal arc welding with electrodes of filler wire used in the qualification procedure tests is to be used. The welding consumables are to be stored and handled in accordance with the manufacturer's recommendations.

**1.13.8** The groove prepared for welding are to be ground smooth and complete elimination of the defective material is to be verified by liquid penetrant testing. Slag, undercuts and other imperfections are to be removed before depositing the next run.

**1.13.9** After weld repair, the castings made of martensitic stainless steel are to be furnace re-tempered. Subject to prior approval, however, local stress relieving may be considered for minor repairs.

**1.13.10** When welding operations are completed, including stress relief heat treatment, welds are to be ground smooth for visual examination and liquid penetrant testing.

**1.13.11** The foundry is to keep full records detailing the welding procedure, heat treatment and extent and location of repairs made on each casting. These records are to be available for review by the surveyor and copies to be handed over to the surveyor on his request.

**1.14 Identification and marking**

**1.14.1** The Manufacturer is to adopt a system of identification which will enable all castings to be traced back to their heats.

**1.14.2** In addition to the indications required in Ch 1, Sec 1, [4.1.1], all castings which have been tested and inspected with satisfactory results are to be marked with the following details:

- a) Manufacturer's mark
- b) grade of cast material
- c) heat number, casting number or another mark enabling the manufacturing process to be traced back
- d) number of the Society's certificate
- e) skew angle if in excess of 25°; see Ch 8, Sec 3, [1.8.1].

**1.14.3** The Manufacturer is to supply the Surveyor with a certificate containing the following details:

- a) purchaser and order number
- b) shipbuilding project number, if known
- c) description of casting with drawing number
- d) diameter, number of blades, pitch, direction of turning
- e) grade of alloy and chemical composition of each heat
- f) heat or casting number
- g) final weight
- h) results of non-destructive tests and details of test procedure, where applicable
- i) results of the mechanical tests
- j) casting identification number
- k) skew angle for high skew propellers; see Ch 8, Sec 3, [1.8.1].



## CHAPTER 7 IRON CASTINGS

---

- Section 1      General Requirements
- Section 2      Grey Iron Castings
- Section 3      Spheroidal or Nodular Graphite Iron Castings

# Section 1 General Requirements

## 1 Scope

### 1.1 General

**1.1.1** The requirements of this Chapter apply to grey lamellar graphite (GG) and spheroidal graphite (SG) iron castings, to be used for the construction of ship structures, machinery, boilers, pressure vessels and piping systems.

The use of cast iron components and the types of cast iron permitted are either regulated by the Chapters of the Rules relevant to the construction of the above-mentioned components, or stipulated in each case.

This Section specifies the requirements common to all the above cast iron products, while the appropriate specific requirements are indicated in Sec 2 and Sec 3.

### 1.2 Mass production

**1.2.1** For mass produced small castings, the Manufacturer may adopt modified procedures for testing and inspection subject to the approval of the Society.

## 2 Casting designation

### 2.1 Cast iron grade

**2.1.1** The designations used in these Rules are as follows:

- a) a first symbol depending on the type of cast iron:
  - “GG” for grey lamellar graphite
  - “SG” for spheroidal or nodular graphite
- b) a second symbol representing the value of the minimum specified tensile strength  $R_m$ , in N/mm<sup>2</sup>.

## 3 Manufacturing

### 3.1 General requirements

**3.1.1** Manufacturers of iron castings are to be recognised by the Society in accordance with NR320.

**3.1.2** Suitable mechanical methods are to be employed for the removal of surplus material from castings. Thermal cutting processes (flame cutting, arc-air cutting) are not acceptable, except as a preliminary operation prior to mechanical methods.

**3.1.3** In connection with [1.2.1] the Manufacturer is to carry out any tests necessary to prove the quality of the prototype castings and is also to make periodical examinations to verify the continued efficiency of the manufacturing technique. The Surveyor is to be given the opportunity to witness these tests.

## 4 Quality of castings

### 4.1 General requirements

**4.1.1** Castings are to be free from surface or internal defects which would be prejudicial to their proper application in service.

## 5 Visual, dimensional and non-destructive examination

### 5.1 General requirements

**5.1.1** Reference is made to the general provisions given in Ch 1, Sec 1, [3.6].

**5.1.2** All castings are to be cleaned and adequately prepared for examination. The surfaces are not to be hammered or treated in any way which may obscure defects.

**5.1.3** Before acceptance, all castings are to be visually examined including, where applicable, the examination of internal surfaces.

**5.1.4** Supplementary examination of castings by suitable non-destructive testing may be required by the Surveyor.

**5.1.5** Dimensions, tolerances and their verification are the responsibility of the Manufacturer.

**5.1.6** When requested in the relevant parts of the Rules, castings are to be pressure tested before final acceptance. These tests are to be carried out in the presence of the Surveyor.

## **6 Repair of defects**

### **6.1 General requirements**

**6.1.1** At the discretion of the Surveyor, small surface blemishes may be removed by grinding.

**6.1.2** Subject to the prior approval of the Surveyor, local porosity may be rectified by impregnation with a suitable plastic filler, provided that the extent of the porosity is such that it does not adversely affect the strength of the casting.

**6.1.3** Repairs by welding are generally not permitted. However, in certain circumstances and in particular when the mechanical strength of the casting is not involved, a repair by welding may be considered.

In such case, all details of the proposed repair together with the welding procedure foreseen are to be submitted to the Society for examination and approval before starting the repair.

## **7 Chemical composition**

### **7.1 General requirements**

**7.1.1** The chemical composition of the iron used is left to the discretion of the Manufacturer, who is to ensure that it is suitable to obtain the mechanical properties specified for the castings.

## **8 Condition of supply**

### **8.1 General requirements**

**8.1.1** Except as required in [8.1.2], castings may be supplied in either the as cast or the heat treated condition.

**8.1.2** For certain applications such as elevated temperature service, or where dimensional stability is important, castings may be required to be given a suitable tempering or stress relieving heat treatment. This is to be carried out after any refining heat treatment and before machining.

## **9 Sampling and testing**

### **9.1 General requirements**

**9.1.1** Test material sufficient for the required tests and possible re-tests is to be provided for each casting or batch of castings.

**9.1.2** Where separately cast test samples are used, they are to be cast in moulds made from the same type of material as that used for the castings and are to be taken towards the end of pouring of the castings. The samples are not to be stripped from the moulds until the metal temperature is below 500°C.

**9.1.3** Where castings are supplied in the heat treated condition, the test samples are to be heat treated together with the castings which they represent. For cast-on samples, the sample is not to be cut off from the casting until the heat treatment is completed.

**9.1.4** All test samples are to be suitably marked to identify them with the castings which they represent.

**9.1.5** Where the results of a tensile or impact test do not comply with the requirements, the re-test procedure indicated in Chapter 2 is to be applied.

## **10 Identification and marking**

### **10.1 General requirements**

**10.1.1** All castings which have been tested and inspected with satisfactory results are to be marked with the following details:

- a) Manufacturer's name or trade mark
- b) Society's brand
- c) identification mark for material designation, as indicated in [2]
- d) cast number or other marking which will enable the history of the fabrication of the casting to be traced
- e) test pressure, where applicable
- f) additional optional marks such as file number and code of the local inspection office, Surveyor's personal brand.

Modified arrangements for identification and marking of small castings manufactured in large numbers may be agreed.

## **11 Documentation and certification**

### **11.1 General requirements**

**11.1.1** The testing documentation indicated in Ch 1, Sec 1, [4.2.1] is to be issued by the Foundry and is to include all the information, as appropriate.

Where applicable, the reports relevant to the non-destructive examination and pressure test are to be enclosed with the testing documentation.

## Section 2 Grey Iron Castings

### 1 Requirements

#### 1.1 Scope

**1.1.1** The requirements of this Section apply to grey iron castings (GG iron castings). The general requirements specified in Sec 1 are also to be complied with, as appropriate.

#### 1.2 Mechanical tests

**1.2.1** Unless otherwise agreed with the Society, separately cast test samples are to be used in the form of bars of 30 mm in diameter and of a suitable length; when two or more test samples are cast simultaneously in a single mould, the bars are to be at least 50 mm apart as given in Fig 1.

In the case of specific components, test samples of other dimensions may be specially required.

**1.2.2** Integrally cast samples may be used when a casting is more than 20 mm thick and its mass exceeds 200 kg, subject to agreement between the Manufacturer and the purchaser. The type and location of the sample are to be selected to provide approximately the same cooling conditions as for the casting it represents and are subject to agreement as well.

**1.2.3** With the exception of [1.2.5] a batch consists of the castings poured from a single ladle of metal; provided that they are all of similar type and dimensions. A batch is not normally to exceed 2 tonnes of fettled castings and a single casting constitutes a batch if its mass is 2 tonnes or more.

**1.2.4** With the exception of [1.2.6] at least one test sample is to be provided for each batch of castings.

**1.2.5** For continuous melting of the same grade of cast iron in large tonnages the mass of a batch may be increased to the output of two hours of pouring.

**1.2.6** If one grade of grey cast iron is melted in large quantities and if production is carefully monitored by systematic checking of the melting process, such as chill testing, chemical analysis or thermal analysis, test samples may be taken at longer intervals as agreed with the Surveyor.

**1.2.7** One tensile test specimen is to be prepared from each test sample. For 30 mm diameter samples, the specimen is to be machined to the dimensions as shown in Ch 2, Sec 2, [1.1.7]. In the case of test samples of other dimensions, the tensile test specimens are to be machined to agreed dimensions.

**1.2.8** All tensile tests are to be carried out in accordance with test procedures given in Ch 2, Sec 2. Unless otherwise agreed all tests are to be carried out in the presence of the Surveyor.

**Figure 1 : Test sample for grey cast iron**

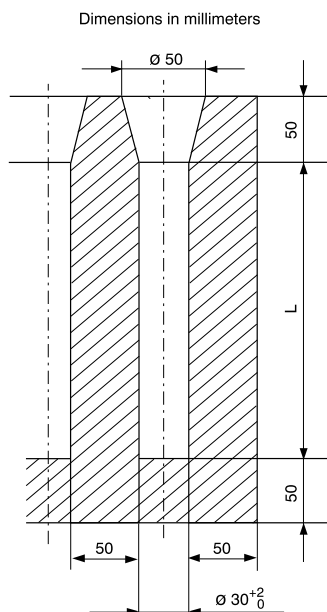

Dimensions in millimetres

### 1.3 Mechanical properties

**1.3.1** Only the tensile strength is to be determined and the results obtained from the tests are to comply with the minimum value specified for the castings supplied. The value selected for the specified minimum tensile strength is to be not less than 200 N/mm<sup>2</sup> and not greater than 350 N/mm<sup>2</sup>. In any event it is to be in accordance with any requirements indicated by the Society on the approved drawings or in the Rules dealing with the relevant parts.

The fractured surfaces of all tensile test specimens are to be granular and grey in appearance.

**1.3.2** Hardness tests may be required in specific cases as a check of homogeneity and are to be performed after the test area has been skinned.

The measured hardness is generally to be between 160 and 220 Brinell units.

# Section 3 Spheroidal or Nodular Graphite Iron Castings

## 1 Requirements

### 1.1 Scope

1.1.1 The requirements of this Section apply to spheroidal or nodular graphite iron castings (SG cast irons) intended for use at ambient temperature.

For other applications, in particular when the castings are intended for service at either low or elevated temperatures, additional requirements and tests may be necessary.

1.1.2 The general requirements specified in Sec 1 are also to be complied with, as appropriate.

### 1.2 Manufacture and condition of supply

1.2.1 The manufacturing process is to be approved for castings intended for crankshafts.

1.2.2 In addition to the general requirements in Sec 1, [8.1.2], a ferritising heat treatment is to be performed for the special qualities SG 350 and SG 400.

1.2.3 Where it is proposed to locally harden the surfaces of a casting full details of the proposed procedure and specification are to be submitted to the Society for approval.

### 1.3 Mechanical tests

1.3.1 The test samples are generally to be one of the standard types detailed in Fig 1, Fig 2 and Fig 3, with a thickness of 25 mm. However, test samples of other dimensions, as detailed in Fig 1 to Fig 3, may be required in some special cases.

Figure 1 : Type A test samples (U type)

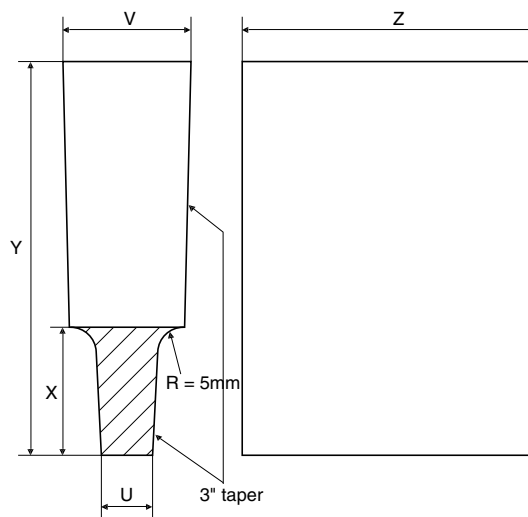

Table 1 : Type A test samples (U type)

Dimensions	Standard sample (mm)	Alternative samples when specially required (mm)		
U	25	12	50	75
V	55	40	90	125
X	40	30	60	65
Y	140	80	150	165
Z	to suit testing machine			

Figure 2 : Type B test samples (double U type)

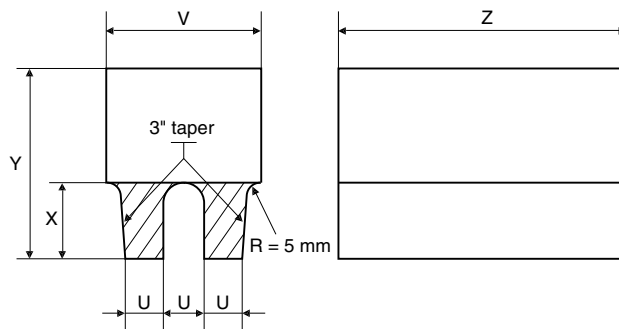

Table 2 : Type B test samples (double U type)

Dimensions	Standard sample (mm)
U	25
V	90
X	40
Y	100
Z	to suit testing machine

Figure 3 : Type C test samples (Y type)

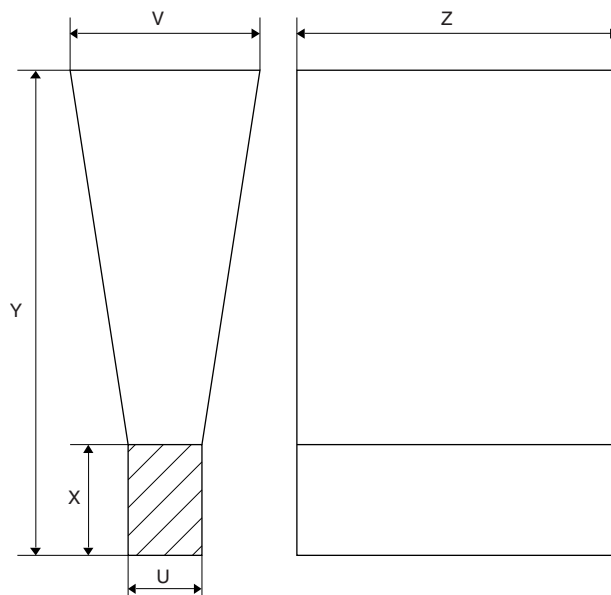

Table 3 : Type C test samples (Y type)

Dimensions	Standard sample (mm)	Alternative samples when specially required (mm)		
U	25	12	50	75
V	55	40	100	125
X	40	25	50	65
Y	140	135	150	175
Z	to suit testing machine			
thickness of mould surrounding test sample	40 mini	40 mini	80 mini	80 mini



**1.3.2** At least one test sample is to be provided for each casting and unless otherwise agreed may be either gated to the casting or separately cast. Alternatively test material of other suitable dimensions may be provided integral with the casting.

For large castings where more than one ladle of treated metal is used, additional test samples are to be provided so as to be representative of each ladle used.

**1.3.3** As an alternative to [1.3.2], a batch testing procedure may be adopted for castings with a fettled mass of 1 tonne or less. All castings in a batch are to be of similar type and dimensions, and cast from the same ladle of treated metal. One separately cast test sample is to be provided for each multiple of 2 tonnes of fettled castings in each batch.

**1.3.4** One tensile test specimen is to be prepared from each test sample and machined to the dimensions given in Chapter 2.

**1.3.5** All tensile tests are to be carried out in accordance with test procedures given in Ch 2, Sec 2. Unless otherwise agreed all tests are to be carried out in the presence of the Surveyor.

Impact tests may be required and in such cases a set of three test specimens of agreed type is to be prepared from each sample. Where Charpy V-notch test specimens are used, the dimensions and testing procedures are to be in accordance with Ch 2, Sec 4.

**1.4 Mechanical properties**

**1.4.1** Unless otherwise agreed only the tensile strength and elongation are to be determined.

**1.4.2** The minimum requirements are given in Tab 4. Typical Brinell hardness values are also given in Tab 4 and are intended for information purpose only.

**1.4.3** Castings may be supplied to any specified minimum tensile strength selected within the general limits detailed in Tab 4 but subject to any additional requirements of the relevant Rules of the Society.

**1.5 Metallographic examination**

**1.5.1** The metallographic examination is required for castings intended for crankshafts.

**1.5.2** When required, a representative sample from each ladle of treated metal is to be prepared for metallographic examination. These samples may be taken from the tensile test specimens, or by an alternative procedure agreed with the Surveyor provided they are taken from the ladle they represent towards the end of the casting period.

**1.5.3** The metallographic examination is to show that at least 90% of the graphite is in a dispersed spheroidal or nodular form. Details of typical matrix structures are given in Tab 4 for information purposes only.

**1.6 Non-destructive examination**

**1.6.1** In addition to the requirements in Sec 1, [5], castings intended for crankshafts are to be subjected to a magnetic particle inspection. Crack like indications are not allowed.

**Table 4 : Mechanical properties**

Qualities	Specified minimum tensile strength $R_m$ (N/mm <sup>2</sup> )	Yield strength $R_{p0.2}$ (N/mm <sup>2</sup> ) min.	Elongation on 5 d (%)	Typical Brinell hardness values	Impact energy		Typical structure of matrix
					Test temp (°C)	KV (J) min (2)	
Ordinary	370	230	17	120 - 180	–	–	Ferrite
	400	250	12	140 - 200	–	–	Ferrite
	500	320	7	170 - 240	–	–	Ferrite/Perlite
	600	370	3	190 - 270	–	–	Ferrite/Perlite
	700	420	2	230 - 300	–	–	Perlite
	800	480	2	250 - 350	–	–	Perlite or Tempered structure
Special	350	220	22 (1)	110 - 170	+20	17 (14)	Ferrite
	400	250	18 (1)	140 - 200	+20	14 (11)	Ferrite

(1) In the case of integrally cast samples, the elongation may be 2 percentage points less.

(2) Average value measured on 3 Charpy V-notch specimens. One result may be below the average value but not lower than the minimum value shown in brackets

**Note 1:** For intermediate values of specified minimum tensile strength, the minimum values for 0,2% proof and elongation may be obtained by interpolation.

## CHAPTER 8 COPPER AND COPPER ALLOYS

---

- Section 1      General Requirements
- Section 2      Copper Alloy Castings
- Section 3      Copper Alloy Castings for Propellers
- Section 4      Copper Alloy Pipes

# Section 1                      General Requirements

## 1 Scope

### 1.1 General

**1.1.1** The requirements of this Chapter apply in addition to those of Chapter 1, Chapter 2 and Chapter 6 to copper or copper alloy tubes and castings including propeller and propeller blade castings.

**1.1.2** Copper alloys and products other than those indicated in this Chapter complying with national or international standards or proprietary specifications deemed equivalent to these requirements may be accepted subject to the approval of the Society.

**1.1.3** Where welding is envisaged, procedures and preparations for the welded joints are to be submitted for approval.

## 2 Manufacturing

### 2.1 General requirements

**2.1.1** The manufacturing procedure and heat treatments suitable to obtain products having the required properties are, in principle, left to the discretion of the Manufacturer.

**2.1.2** The manufacturing process is to ensure that copper or copper alloy products are free from internal or surface defects which may impair their proper workability and use.

**2.1.3** Reference is made to the general provisions given in Ch 1, Sec 1, [3.6] for visual, dimensional and non-destructive examination.

## 3 Testing

### 3.1 General requirements

**3.1.1** Tensile tests required in this Chapter are to be carried out on cylindrical test specimens of the type defined in Ch 2, Sec 2, [1.1.4] with a gauge length equal to:

$$L_0 = 5,65\sqrt{S_0} = 5d \text{ (specimen A)}$$

## 4 Documentation and certification

### 4.1 General requirements

**4.1.1** The testing documentation is to contain the information required in Ch 1, Sec 1, [4.2.1].

## Section 2 Copper Alloy Castings

### 1 Requirements

#### 1.1 Scope

**1.1.1** The requirements of this Section apply to copper alloy castings intended for various uses, with the exception of castings intended for propeller and propeller blades.

#### 1.2 Manufacture

**1.2.1** Manufacturers of copper alloy castings are to be recognised by the Society in accordance with NR320.

**1.2.2** The approval of the manufacturing procedure may be required by the Society on a case-by-case basis for products intended for important uses.

#### 1.3 Condition of supply

**1.3.1** Copper alloy castings may be supplied, at the discretion of the Manufacturer, in either the as cast or heat treated condition unless otherwise specified.

**1.3.2** When castings are supplied in the heat treated condition, the Manufacturer is to provide the Surveyor with the details of the heat treatment used on the casting.

#### 1.4 Chemical composition

**1.4.1** The chemical compositions are to comply with the requirements given in Tab 1.

**1.4.2** The Manufacturer is to issue a cast certificate. When castings are made from ingots for which an analysis is already available, and provided that no alloy additions are made, the certified analysis made by the maker of the ingots may be accepted subject to occasional checks as requested by the Surveyor.

#### 1.5 Mechanical properties

**1.5.1** Mechanical properties are to comply with the appropriate requirements specified in Tab 2.

#### 1.6 Mechanical tests

**1.6.1** Test material sufficient for the required tests and possible re-tests is to be provided for each copper alloy casting.

**1.6.2** The batch is to be made by castings from the same heat, and treated in the same furnace charge if delivered in the heat treated condition.

**1.6.3** In the case of heat treated material, test samples are to be treated in the same way and, in general, together with the material they represent.

**1.6.4** For each test sample, a tensile test specimen is prepared, machined at the dimensions specified in Sec 1, [3].

#### 1.7 Visual and non-destructive examination

**1.7.1** All castings are to be cleaned and adequately prepared for inspection.

**1.7.2** The Manufacturer is responsible for compliance with dimensions and tolerances.

**1.7.3** Before acceptance, all castings are to be presented for visual examination. This is to include the examination of the external and internal surfaces of each casting of the batch and, if necessary, the dye-penetrant test for copper-aluminium and copper-nickel castings.

In addition, for certain copper alloy castings submitted to heavy stresses, the Surveyor may require radiographic and ultrasonic testing.

**1.7.4** Unless otherwise required in other relevant Society's Rules, copper alloy castings submitted to pressure are to undergo a hydrostatic test at a pressure equal to twice the service pressure.

The Manufacturer is to issue a certificate for these tests and the Surveyor may ask to attend all or part of such tests.

**Table 1 : Castings - Chemical composition (%)**

Name of alloy	Cu	Sn	Pb	Zn	Fe	Ni	Al	Mn	Si	P	Others
High tensile brass	57/65	≤ 1,0	≤ 0,5	rem.	0,5/2,0	≤ 3,0	0,5/2,5	0,1/3,0	≤ 0,10		Sb+P+As ≤ 0,40
Leaded bronze	80/87 (1)	4,0/6,0	8,0/11	≤ 2,0	≤ 0,25	≤ 2,0	≤ 0,01	≤ 0,2	≤ 0,01	≤ 0,10	S ≤ 0,10
Phosphor bronze	86/89,5 (1)	9,5/12	≤ 0,5	≤ 0,5	≤ 0,10	≤ 0,2	≤ 0,01	–	≤ 0,02	0,15/1,5	
Bronze Cu Sn10 Zn2 (Gunmetal)	86/89	9,0/11	≤ 1,5	1,0/3,0	≤ 0,25	≤ 2,0	≤ 0,01	≤ 0,2	≤ 0,01	0,05	S ≤ 0,10 Sb ≤ 0,30
Bronze Cu Pb5 Sn5 Zn5 (leaded Gunmetal)	84/86 (1)	4,0/6,0	4,0/6,0	4,0/6,0	≤ 0,30	≤ 2,5	≤ 0,01	–	≤ 0,01	0,05	
Copper- aluminium	88/92 (1)	≤ 0,30	≤ 0,02 (2)	≤ 0,40	2,0/5,0	≤ 3,0	8,5/11	≤ 1,0	≤ 0,20		
Nickel copper aluminium	> 76	≤ 0,20	≤ 0,02 (2)	≤ 0,50	3,5/5,5	3,5/6,5	8,0/11 (4)	≤ 3,0	≤ 0,10		Cu+Fe+Ni+Al +Mn ≥ 99,2
Copper-nickel 90 / 10	rem.	–	≤ 0,02 (2)	≤ 0,50 (2)	1,0/1,8	9,0/11	–	0,5/1,0	–	0,20	S ≤ 0,20 (3) C ≤ 0,05
Copper-nickel 70 / 30	rem.	–	≤ 0,02 (2)	≤ 0,50 (2)	0,4/1,0	29/32	–	0,5/1,5	–	0,20	S ≤ 0,20 C ≤ 0,05

(1) Nickel included.  
(2) When no welding is to be done on the pieces, Pb content may be in the range from 0,1% to 0,3%, Zn content may be up to 1,0% and there are no requirements for C, S and P.  
(3) Cu + Fe + Mn + Ni +Pb ≥ 99,5%  
(4) If this nickel copper aluminium is to withstand sea corrosion, it is necessary that Al ≤ 8,2 + Ni/2  
**Note 1:** rem. = remainder.

**Table 2 : Castings - Mechanical characteristics**

Name of Alloy	R <sub>m</sub> (N/mm <sup>2</sup> )	R <sub>p0,2</sub> (N/mm <sup>2</sup> ) (1)	A (%) on 5d (or 5,65 √S <sub>o</sub> )
High tensile brass	≥ 450	≥ 170	≥ 20
Leaded bronze	≥ 230	≥ 130	≥ 9
Phosphor bronze	≥ 220	≥ 130	≥ 6
Bronze (Gunmetal) Cu Sn10 Zn2	≥ 240	≥ 120	≥ 12
Bronze Cu Pb5 Sn5 Zn5 (leaded Gunmetal)	≥ 200	≥ 90	≥ 13
Copper-aluminium	≥ 450	≥ 160	≥ 15
Nickel copper aluminium	≥ 600	≥ 250	≥ 12
Copper-nickel 90 / 10	≥ 320	≥ 160	≥ 20
Copper-nickel 70 / 30	≥ 420	≥ 220	≥ 20

(1) Values of yield stress at 0,2% offset are indicated for guidance only and, unless specially requested, are not required to be checked during the tensile test.

## 1.8 Rectification of defective castings

**1.8.1** The evaluation of defects, where present, and the necessity and the acceptance of the means of rectification are left to the discretion of the Surveyor; to this end, additional checks may be required.

**1.8.2** The Surveyor may accept that castings containing local porosities are rectified by impregnation with a suitable plastic filler, provided that the porosities do not adversely affect the mechanical strength of the casting.

**1.8.3** Welded repairs are not acceptable, as a rule, unless expressly authorised by the Surveyor.

Any proposal to repair a defective casting by welding is to be previously submitted to the Surveyor, who may require that tests are performed to qualify the proposed welding procedure.

### 1.9 Identification and marking

**1.9.1** The Manufacturer is to adopt a system of identification which will enable all finished castings to be traced to the original cast.

In addition to the indications required in Ch 1, Sec 1, [4.1.3], all castings which have been tested and inspected with satisfactory results are to be marked with the following details:

- a) Manufacturer's name or trade mark
- b) identification number, cast number or other markings which will enable the full history of the casting to be traced
- c) test pressure, where applicable.

**1.9.2** Modified arrangements for identification and marking of small castings manufactured in large numbers may be agreed with the Surveyor.

# Section 3 Copper Alloy Castings for Propellers

## 1 Requirements

### 1.1 Scope

**1.1.1** The requirements of this Section are applicable to the manufacture, inspection and repair procedures of new cast copper alloy propellers, blades and bosses.

**1.1.2** These requirements may also be applied for the repair and inspection of propellers which become damaged during service.

### 1.2 Manufacturing

#### 1.2.1 Approval

Manufacturers of cast copper alloy propellers are to be recognised by the Society in accordance with NR320.

Manufacturing process of cast copper alloy propellers is to be approved as per NR480 "Approval of the manufacturing process of metallic materials".

**1.2.2** These castings are to be manufactured and tested in accordance with the appropriate requirements of Chapter 1, Chapter 2 and Chapter 6 and the specific requirements of this Section.

### 1.3 Quality of castings

**1.3.1** All castings are to be free from surface or internal defects, such as cracks, hot tears or other imperfections which would be prejudicial to their proper application in service. Minor casting defects which may still be visible after machining, such as small cold shots and scabs, are to be trimmed off by the Manufacturer in accordance with [1.12].

### 1.4 Condition of supply

**1.4.1** At the option of the Manufacturer, castings may be supplied in the "as cast" or heat treated condition.

### 1.5 Chemical composition

**1.5.1** Typical copper propeller alloys are grouped into the four types CU1, CU2, CU3, and CU4 depending on their chemical composition as given in Tab 1. Copper alloys whose chemical composition deviates from the typical values of Tab 1 are to be specially approved by the Society.

**1.5.2** The Manufacturer is to maintain records of the chemical analyses of the production casts, which are to be made available to the Surveyor so that he can satisfy himself that the chemical composition of each casting is within the specified limits.

**1.5.3** For copper-based alloys CU1 and CU2, in order to ensure adequate cold ductility and corrosion fatigue resistance, the proportion of beta phase is to be kept low. For this purpose, the zinc equivalent defined by the following formula is not to exceed a value of 45%:

$$\text{Zinc equivalent (\%)} = 100 - (100 \cdot \%Cu / (100 + A))$$

in which  $A = \%Sn + 5 \cdot \%Al - 0,5 \cdot \%Mn - 0,1 \cdot \%Fe - 2,3 \cdot \%Ni$

Note 1: The negative sign in front of the element Mn, Fe and Ni signifies that these elements tend to reduce the proportion of beta phase.

**1.5.4** In addition to [1.5.3], the CU1 and CU2 type alloys are to contain an alpha phase component of at least 25%; this is to be checked on a test bar by the Manufacturer.

**Table 1 : Typical chemical composition of propeller and propeller blade castings**

Alloy Type	CHEMICAL COMPOSITION (%)							
	Cu	Sn	Zn	Pb	Ni	Fe	Al	Mn
CU1	52 - 62	max. 1,5	35 - 40	max. 0,50	max. 1,0	0,5 - 2,5	0,5 - 3,0	0,5 - 4,0
CU2	50 - 57	max. 1,5	33 - 38	max 0,50	3,0 - 8,0	0,5 - 2,5	0,5 - 2,0	1,0 - 4,0
CU3	77 - 82	max. 0,10	max. 1,0	max 0,03	3,0 - 6,0	2,0 - 6,0	7,0 - 11,0	0,5 - 4,0
CU4	70 - 80	max. 1,00	max. 6,0	max 0,05	1,5 - 3,0	2,0 - 5,0	6,5 - 9,0	8,0 - 20,0

**1.6 Mechanical properties**

**1.6.1** The requirements relevant to the mechanical properties are shown in Tab 2.

The values given in Tab 2 are applicable to test specimens taken from separately cast samples in accordance with Fig 1, or with any other recognised national standard.

It is to be noted that these properties are generally not representative of the mechanical properties of the propeller casting itself, which may be lower than that of a separately cast test coupon.

For integrally cast test specimens, the requirements are to be specially agreed with the Society; wherever possible, the test samples are to be located on the blades in an area lying between 0,5 to 0,6 R, where R is the radius of the propeller. The test sample material is to be removed from the casting by non-thermal procedures.

The mechanical properties of alloys not meeting the limiting values of Tab 2 are to comply with the requirements of the relevant specification to be approved by the Society.

**1.7 Sampling and testing**

**1.7.1** Test samples are to be provided from each cast used for the manufacture of propeller blade casting.

**1.7.2** The test samples are to be of keel block type, in accordance with the dimensions in Fig 1. They are to be cast in moulds made from the same type of materials as used for the castings and they must be cooled down under the same condition as the propeller.

**1.7.3** Where castings are supplied in the heat treated condition, the test samples are to be heat treated together with the casting which they represent.

**1.7.4** At least one tensile test specimen is to be taken from each ladle.

**1.7.5** The results of all tensile tests are to comply with the requirements given in Tab 2.

**1.7.6** Metallographic examination of alloy types CU1 and CU2 is to be verified by determining the proportion of alpha phase. For this purpose, at least one specimen is to be taken from each heat. The proportion of alpha phase is to be determined as the average value of 5 counts. The requirements of [1.5.4] are to be fulfilled.

**Figure 1 : Keel block test sample casting**

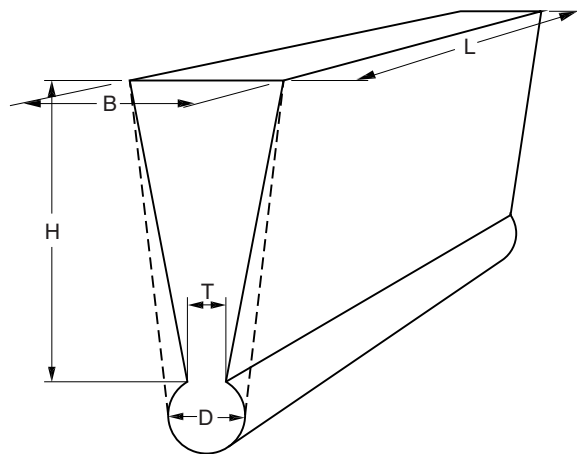

H = 100 mm; B = 50 mm; L > 150 mm; T = 15 mm; D = 25 mm

**Table 2 : Mechanical properties of cast copper alloys for propellers and propeller blade castings**

Alloy type	Proof stress $R_{p0,2}$ (N/mm <sup>2</sup> ) min.	Tensile strength $R_m$ (N/mm <sup>2</sup> ) min.	Elongation A5 (%) min.
CU1	175	440	20
CU2	175	440	20
CU3	245	590	16
CU4	275	630	18

**Note 1:** The values shown are related to specimens taken from separately cast samples as per Fig 1 or recognised national standards.

**Note 2:** The 0,2% proof stress values are to be determined for all keyless type propeller castings. For other types of propeller casting, these values are given for information purposes only and, unless expressly required, their determination may be omitted during testing.



**1.8 Definition of skew, severity zones**

**1.8.1** The skew of a propeller is defined as follows:

The maximum skew angle of a propeller blade is defined as the angle, in the projected view of the blade, between a line drawn through the blade tip and the shaft centreline and a second line through the shaft centreline which acts as a tangent to the locus of the mid-points of the helical blade section; see Fig 2.

High skew propellers have a skew angle greater than 25°, low skew propellers a skew angle of up to 25°.

**Figure 2 : Definition of skew angle**

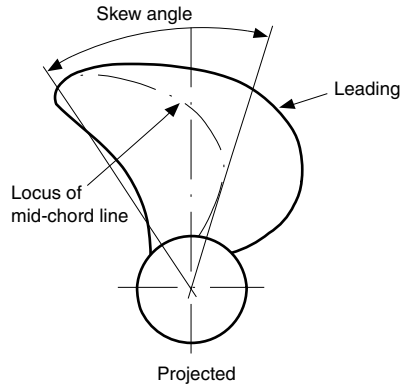

**1.8.2** Severity zones for low skew propellers are as follows:

Zone A is the area on the pressure side of the blade, from and including the fillet to 0,4R, and bounded on either side by lines at a distance 0,15 times the chord length  $C_r$  from the leading edge and 0,2 times  $C_r$  from the trailing edge, respectively (see Fig 3). Where the hub radius ( $R_b$ ) exceeds 0,27R, the other boundary of zone A is to be increased to 1,5 $R_b$ . Zone A also includes the parts of the separate cast propeller hub which lie in the area of the windows as described in Fig 4 and the flange and fillet area of controllable pitch and built-up propeller blades as described in Fig 5.

Zone B is on the pressure side the remaining area up to 0,7 R and on the suction side the area from the fillet to 0,7 R (see Fig 3).

Zone C is the area outside 0,7 R on both sides of the blade. It also includes the surface of the hub of a controllable pitch propeller other than those designated Zone A above.

**1.8.3** Severity zones for high skew propellers are as follows:

Zone A is the area on the pressure face contained within the blade root-fillet and a line running from the junction of the leading edge with the root fillet to the trailing edge at 0,9 R and at passing through the mid-point of the blade chord at 0,7 R and a point situated at 0,3 of the chord length from the leading edge at 0,4 R. It also includes an area along the trailing edge on the suction side of the blade from the root to 0,9 R and with its inner boundary at 0,15 of the chord length from the trailing edge.

Zone B constitutes the whole of the remaining blade surfaces.

Zones A and B are illustrated in Fig 6.

**Figure 3 : Severity zones for integrally cast low skew propellers**

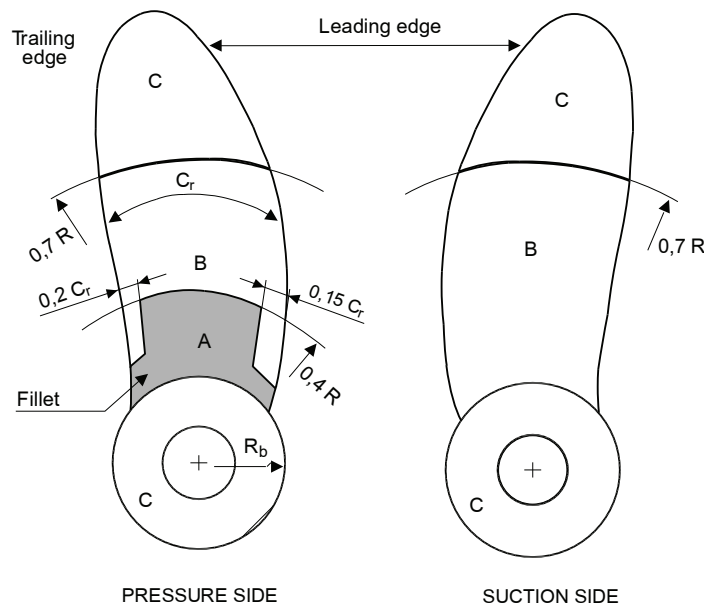

$C_r$  : Local chord length

Figure 4 : Severity zones for controllable pitch propeller boss

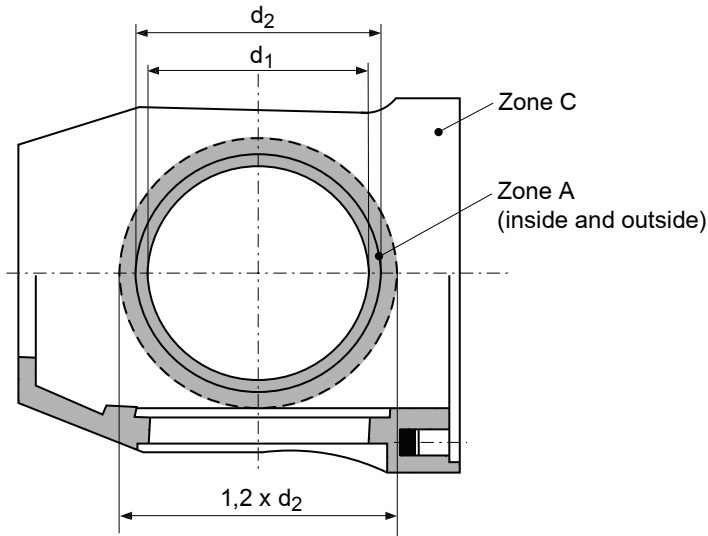

Figure 5 : Severity zones for controllable pitch and built-up propeller

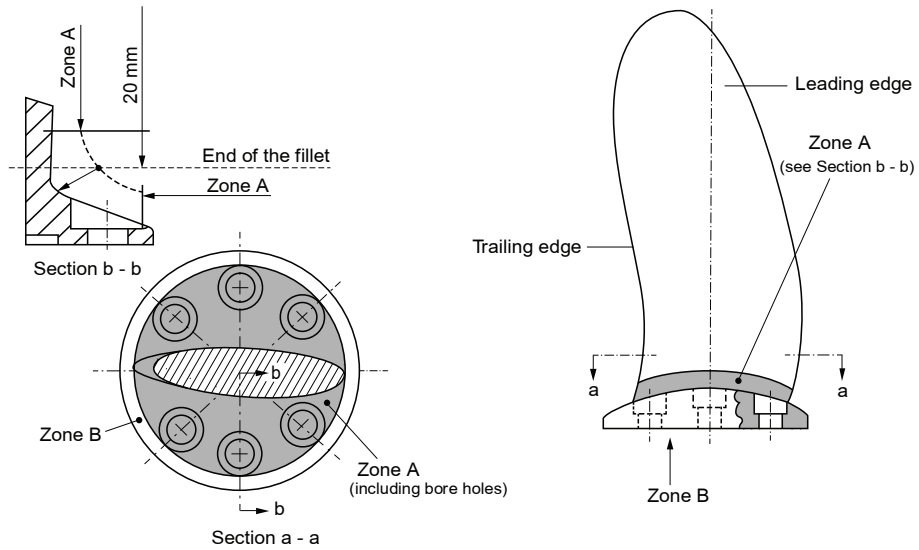
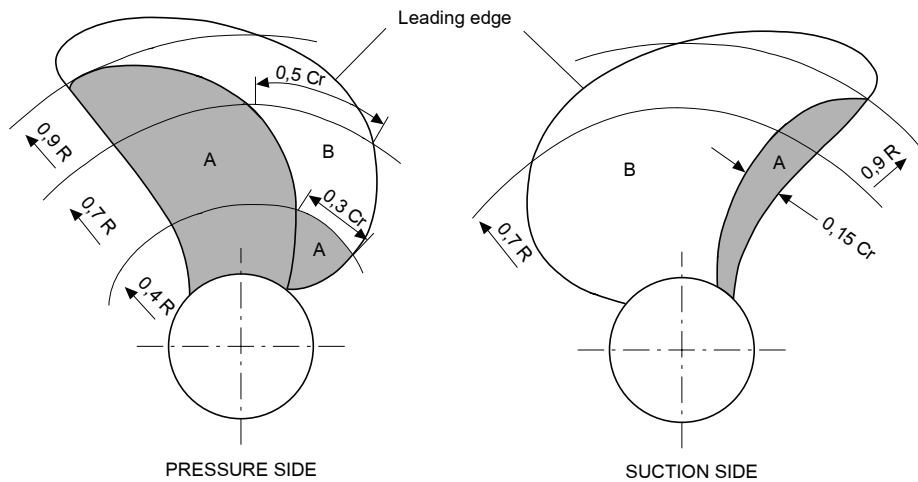

Figure 6 : Severity zones in blades with skew angles > 25°



Cr : Local chord length

## **1.9 Visual and dimensional examination**

**1.9.1** All finished castings are to be 100% visually inspected by the manufacturer.

**1.9.2** A general visual examination is to be carried out by the Surveyor.

**1.9.3** The dimensions, the dimensional and geometrical tolerances and their verification are the responsibility of the Manufacturer. The report on the relevant examinations is to be submitted to the Surveyor, who may require checks to be made in his presence.

**1.9.4** Static balancing is to be carried out on all propellers.

Dynamic balancing is required for propellers running above 500 rpm.

## **1.10 Non-destructive testing**

### **1.10.1 Liquid penetrant examination**

Liquid penetrant testing procedure is to be submitted to the Society and is to be in accordance with ISO 3452-1:2013 or a recognised standard. The acceptance criteria are specified in [1.11].

The severity zone A is to be subjected to a liquid penetrant testing in the presence of the Surveyor.

In zones B and C the liquid penetrant testing is to be performed by the manufacturer and may be witnessed by the Surveyor upon his request.

If repairs have been made either by grinding, straightening or by welding the repaired areas are additionally to be subjected to the liquid penetrant testing independent of their location and/or severity zone.

### **1.10.2 Radiographic and ultrasonic examination**

When required by the Society or when deemed necessary by the manufacturer, further non-destructive testing (e.g. radiographic and/or ultrasonic testing) are to be carried out. The acceptance criteria or applied quality levels are to be agreed between the manufacturer and the Society in accordance with a recognised standard.

## **1.11 Acceptance criteria for liquid penetrant testing**

### **1.11.1 Definitions**

The following definitions relevant to liquid penetrant indications apply:

- Indication:  
In the liquid penetrant testing an indication is the presence of detectable bleed-out of the penetrant liquid from the material discontinuities appearing at least 10 minutes after the developer has been applied.
- Relevant indication:  
Only indications which have any dimension greater than 1.5mm shall be considered relevant for the categorization of indications.
- Non-linear indication:  
An indication with a largest dimension less than three times its smallest dimension.
- Linear indication:  
An indication with a largest dimension three or more times its smallest dimension.
- Aligned indication:
  - Non-linear indications form an alignment when the distance between indications is less than 2 mm and at least three indications are aligned. An alignment of indications is considered to be a unique indication and its length is equal to the overall length of the alignment.
  - Linear indications form an alignment when the distance between two indications is smaller than the length of the longest indication.

Illustration of liquid penetrant indication is given in Fig 7.

### **1.11.2 Acceptance standard**

The surface to be inspected is to be divided into reference areas of 100 cm<sup>2</sup>. Each reference area may be square or rectangular with the major dimension not exceeding 250 mm.

The area shall be taken in the most unfavourable location relative to the indication being evaluated.

The relevant indications detected shall, with respect to their size and number, not exceed the values given in the Tab 3.

Figure 7 : Shape of indications

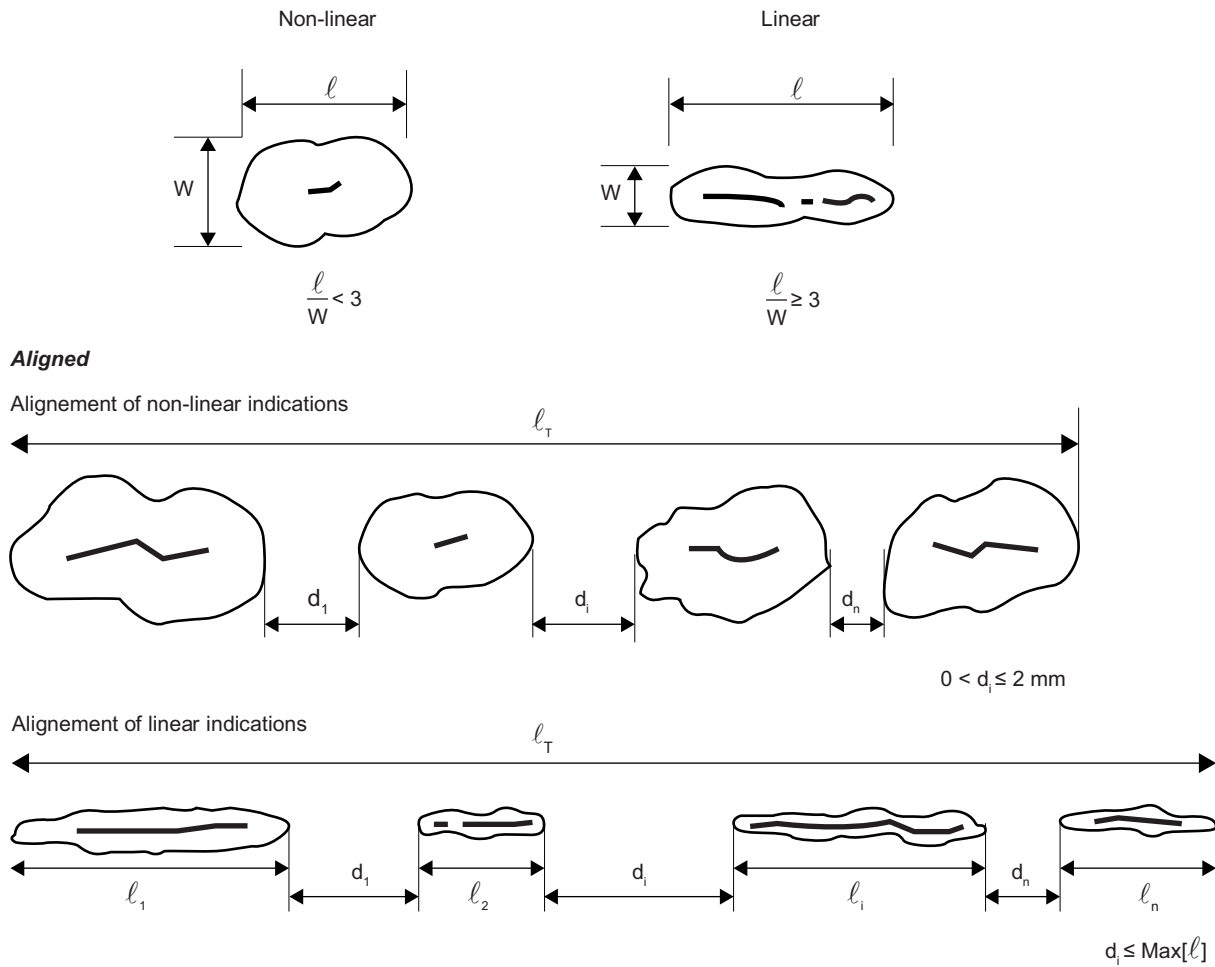

Table 3 : Allowable number and size of relevant indications in a reference area of 100 cm<sup>2</sup>, depending on severity zones

Severity zones	Max. total number of indications	Type of indication	Max. number of each type (1) (2)	Max. acceptable value for "l" of indications (mm)
A	7	non-linear	5	4
		linear	2	3
		aligned	2	3
B	14	non-linear	10	6
		linear	4	6
		aligned	4	6
C	20	non-linear	14	8
		linear	6	6
		aligned	6	6

(1) Singular non-linear indications less than 2 mm for zone A and less than 3 mm for the other zones are not considered relevant.  
 (2) The total number of non-linear indications may be increased to the maximum total number, or part thereof, represented by the absence of linear or aligned indications.

## 1.12 Repair of defects

### 1.12.1 Repair procedures

Indications exceeding the acceptance standard of Tab 3, cracks, shrinkage cavities, sand, slag and other non-metallic inclusions, blow holes and other discontinuities which may impair the safe service of the propeller are defined as defects and must be repaired.

In general the repairs shall be carried out by mechanical means, e. g. by grinding, chipping or milling. Welding may be applied subject to the agreement of the Society if the relevant requirements detailed hereafter are satisfied.

After milling or chipping, grinding is to be applied for such defects which are not to be welded. Grinding is to be carried out in such a manner that the contour of the ground depression is as smooth as possible. Complete elimination of the defective material is to be verified by liquid penetrant testing.

Localised pores on the end face or bore of a propeller boss, which themselves do not affect the strength of the casting, can be filled with a suitable plastic filler after the appropriate preparation of the defective area. The foundry is to keep records and details of all castings which have been rectified.

### 1.12.2 Repair of defects in zone A

In zone A, repair welding will generally not be allowed unless specially approved by the Society.

In some cases the propeller designer may submit technical documentation to propose a modified zone A based on detailed hydrodynamic load and stress analysis for consideration by the Society.

Grinding can be carried out to an extent which maintains the blade thickness of the approved drawings.

The possible repair of defects which are deeper than those referred to above is to be considered by the Society.

### 1.12.3 Repair of defects in zone B

Defects that are not deeper than  $dB = (t/40)$  mm ( $t$  is the minimum local thickness in mm according to the Rules) or 2 mm, whichever is greatest, below minimum local thickness according to the Rules should be removed by grinding. Those defects that are deepest than allowable for removal by grinding may be repaired by welding.

### 1.12.4 Repair of defects in zone C

In zone C, repair welds are generally permitted.

## 1.13 Weld repair

**1.13.1** All weld repairs are to be documented by means of sketches or photographs showing the location and major dimensions of the grooves prepared for welding. Weld repairs are to be undertaken only when they are considered to be necessary and have prior agreement of the Surveyor.

**1.13.2** Before welding is started, the company concerned shall prepare and submit to the Society a detailed welding procedure specification covering the weld preparation, welding position, welding parameter, welding consumables, preheating and post weld heat treatment and inspection procedures.

All weld repairs are to be carried out in accordance with qualified procedures, and, by welders who are qualified to a recognized standard.

Welding Procedure Qualification Tests are to be carried out in accordance with Ch 12, Sec 4, [6] and witnessed by the Surveyor.

**1.13.3** Areas which are prepared for welding are to be liquid penetrant tested and independent of their location always to be assessed in accordance with criteria for zone A.

**1.13.4** Welding of areas less than 5cm<sup>2</sup> is to be avoided.

**1.13.5** For new propellers, the area of any single repair and the maximum total area in any zone or region are generally to be kept within the following limits, where  $S$  is the blade surface:

- a) Zone A: not generally permitted
- b) Zone B and C, single:  $0,006S$  or 60cm<sup>2</sup>, whichever is the greater
- c) Zone B (leading edge), total:  $0,008S$  or 100cm<sup>2</sup>, whichever is the greater
- d) Zone B+C, total:  $0,02S$  or 200cm<sup>2</sup>, whichever is the greater
- e) Other zones, total for each zone:  $0,05S$  or 50cm<sup>2</sup>, whichever is the greater. Other zones means in particular the following zones:
  - for integrally cast propellers
    - within the bore
    - outer surfaces of the boss to the start of the fillet radius
    - forward and aft end faces of the boss
  - for separately cast propeller blades
    - surfaces of the flange to the start of the fillet radius

**1.13.6** Welding is to be done under cover in conditions free from draughts and adverse weather.

**1.13.7** Metal arc welding with electrodes of filler wire used in the qualification procedure tests is to be used. The welding consumables are to be stored and handled in accordance with the manufacturer’s recommendations.

**1.13.8** The groove prepared for welding are to be ground smooth and complete elimination of the defective material is to be verified by liquid penetrant testing. Slag, undercuts and other imperfections are to be removed before depositing the next run.

**1.13.9** With the exception of alloys type CU3 (Ni-Al bronze) all weld repairs are to be stress relief heat treated. However, stress relief heat treatment of alloy type CU3 castings is required after major repairs in zone B (and zone A when specially approved) or if a welding consumable depositing a metal susceptible to stress corrosion cracking is used (e.g. with chemical composition of alloy type CU4).

**1.13.10** Stress relief heat treatment is to be within the following temperature range:

- CU1: 350°C - 500°C
- CU2: 350°C - 550°C
- CU3: 450°C - 500°C
- CU4: 450°C - 600°C

Soaking times are to be in accordance with Tab 4. The heating and cooling are to be suitably controlled to minimize residual stresses. The cooling rate after any stress relieving heat treatment is not to exceed 50°C/h until the temperature of 200°C is reached.

**1.13.11** When welding operations are completed, including stress relief heat treatment, welded areas in finished machined and/or grinded condition are to be subjected to visual examination and liquid penetrant test and assessed to zone A.

**1.13.12** The foundry is to keep full records detailing the welding procedure, heat treatment and extent and location of repairs made on each casting. These records are to be available for review by the surveyor and copies to be handed over to the surveyor on his request.

**1.14 Straightening**

**1.14.1 Application of load**

For hot and cold straightening purposes, static loading only is to be used.

**1.14.2 Hot straightening**

Weld repaired areas may be subject to hot straightening, provided it can be demonstrated that weld properties are not impaired by the hot straightening operations.

Hot straightening of a bent propeller blade or a pitch modification is to be carried out after heating the bent region and approximately 500 mm wide zone on either side of it to the following suggested temperature range:

- alloy grade CU1: 500°C - 800°C
- alloy grade CU2: 500°C - 800°C
- alloy grade CU3: 700°C - 900°C
- alloy grade CU4: 700°C - 850°C

The heating is to be slow and uniform and the concentrated flames, such as oxy-acetylene and oxy-propane, are not to be used. Sufficient time is to be allowed for the temperature to become fairly uniform through the full thickness of the blade section. The temperature is to be maintained within the suggested range throughout the straightening operation. A thermocouple instrument or temperature indicating crayons is/are to be used for measuring the temperature.

**Table 4 : Soaking times for stress relief heat treatment of copper alloy propellers**

Stress relief temperature (°C)	Alloy Grade Cu 1 and Cu 2		Alloy Grade Cu 3 and Cu 4	
	Hours per 25 mm of thickness	Maximum recommended total hours	Hours per 25 mm of thickness	Maximum recommended total hours
350	5	15	–	–
400	1	5	–	–
450	1/2	2	5	15
500	1/4	1	1	5
550	1/4	1/2	1/2	2
600	–	–	1/4 <b>(1)</b>	1 <b>(1)</b>
650	–	–	1/4 <b>(1)</b>	1/2 <b>(1)</b>

**(1)** 600°C and 650°C applicable to CU4 alloys only.

### 1.14.3 Cold straightening

Cold straightening is to be used for minor repairs of tips and edges only. Cold straightening on castings made of alloy type CU1, CU2 and CU4 are always to be followed by a stress relief heat treatment; see Tab 4.

### 1.15 Identification and marking

**1.15.1** The Manufacturer is to adopt a system of identification which will enable all castings to be traced back to their heats.

**1.15.2** In addition to the indications required in Ch 1, Sec 1, [4.1.1], all castings which have been tested and inspected with satisfactory results are to be marked with the following details:

- a) Manufacturer's mark
- b) grade of cast material
- c) heat number, casting number or another mark enabling the manufacturing process to be traced back
- d) number of the Society's certificate
- e) skew angle if in excess of 25°; see [1.8.1].

**1.15.3** The Manufacturer is to supply the Surveyor with a certificate containing the following details:

- a) purchaser and order number
- b) shipbuilding project number, if known
- c) description of casting with drawing number
- d) diameter, number of blades, pitch, direction of turning
- e) grade of alloy and chemical composition of each heat
- f) heat or casting number
- g) final weight
- h) results of non-destructive tests and details of test procedure, where applicable
- i) portion of alpha-structure for CU1 and CU2 alloys
- j) results of the mechanical tests
- k) casting identification number
- l) skew angle for high skew propellers; see [1.8.1].

# Section 4 Copper Alloy Pipes

## 1 Requirements

### 1.1 Scope

1.1.1 The requirements of this Section apply to copper alloy pipes intended for condensers, heat exchangers and pressure lines.

### 1.2 Manufacture

1.2.1 Manufacturers of copper alloy pipes are to be recognised by the Society in accordance with the NR320.

### 1.3 Condition of supply

1.3.1 Copper and copper alloy pipes are to be delivered annealed (recrystallised with fine grain). Copper pipes may also be delivered hard drawn.

1.3.2 Aluminium brass pipes may additionally be required to be given a suitable stress relieving heat treatment when subjected to a cold straightening operation after annealing.

### 1.4 Chemical composition

1.4.1 The chemical composition of copper alloys used for the manufacture of pipes is to comply with the requirements given in Tab 1 and a corresponding heat certificate is to be issued by the Manufacturer.

### 1.5 Mechanical properties

1.5.1 The mechanical properties are to comply with the appropriate requirements given in Tab 2.

### 1.6 Mechanical tests

1.6.1 One series of tests is to be conducted on each batch of 200 pipes coming from the same fabrication and same heat, and having the same size and delivery condition (heat treatment).

**Table 1 : Pipes - Chemical composition (%)**

Name of alloys	Cu (1)	Sn	Al	Ni (1)	Pb	Fe	Zn	Mn	As	Residual elements
Copper-phosphorus (arsenical or non arsenical)	≥ 99,85								0,30/0,50	P = 0,013/0,050 deoxidised
Tin Brass (naval)	70/73	0,9/1,2			≤ 0,07	≤ 0,06	remainder		0,02/0,06	total impurities + Pb + Fe ≤ 0,3
Aluminium Brass	76/79		1,8/2,5		≤ 0,07	≤ 0,06	remainder		0,02/0,06	total impurities + Pb + Fe ≤ 0,3
Copper-nickel 90/10 (2)	remainder			9,0/11	≤ 0,02	1,0/2,0	≤ 0,5	0,3/1,0		C ≤ 0,05–S+P ≤ 0,02 total others ≤ 0,1
Copper-nickel 70/30 (2)	remainder			29/33	≤ 0,02	0,4/1,0	≤ 0,5	0,5/1,5		C ≤ 0,05–S+P ≤ 0,02 total others ≤ 0,1
Special copper-nickel 70/30 (2)	remainder	Sn+Pb ≤ 0,05		29/32	≤ 0,02	1,5/2,0	≤ 0,5	1,5/2,0		C ≤ 0,05–S+P ≤ 0,02 total others ≤ 0,1
Copper-Alu 6	≥ 93,0	0,15/0,5	5,0/6,5		≤ 0,02	≤ 1,0	≤ 0,3			total impurities ≤ 0,5

(1) Silver is considered as copper; cobalt as nickel.

(2) When no welding is to be done on copper-nickel pipes, there are no requirements regarding P, S and C, and the Zn content may be up to 1%, the Pb content up to 0,05%.



**Table 2 : Pipes - Mechanical properties**

Name of Alloy	R <sub>m</sub> (N/mm <sup>2</sup> )	R <sub>e0,2</sub> (N/mm <sup>2</sup> )	A (%) on 5,65√S <sub>0</sub>
Copper-phosphorus (arsenical or non arsenical) <b>(1)</b>	≥ 220 ≥ 230 ≥ 270	≥ 100 ≥ 155 for guidance	≥ 35 (annealed) ≥ 20 (quarter-hard temper) ≥ 10 (half-hard temper)
Tin Brass	≥ 310	≥ 105	≥ 35
Aluminium Brass	≥ 345	≥ 125	≥ 35
Copper-nickel 90/10	≥ 290	≥ 105	≥ 30
Copper-nickel 70/30	≥ 360	≥ 125	≥ 30
Special copper-nickel 70/30	≥ 420	≥ 125	≥ 30
Copper-Alu 6	≥ 345	≥ 130	≥ 40
<b>(1)</b> In the case of copper-phosphorus, the tensile test may be replaced by the HV hardness test when this is specified in certain national standards.			

**1.6.2** At least one length is to be selected at random from each batch for the following tests:

- one tensile test
- one flattening test
- one drift expanding test.

The procedures for mechanical tests and the dimensions of the test specimens are to be in accordance with Chapter 2, with the additions and/or modifications as per the present item.

**1.6.3** A tensile test is to be carried out on a specimen consisting of a pipe length of full section, or of a strip cut longitudinally in the pipe and of the same thickness as the pipe.

**1.6.4** The flattening test consists of slowly flattening a section of pipe 50 mm long by one stroke of a press.

After flattening to a distance between platens equal to three times the thickness of the pipe, no cracking, rupture or defects are to be visible to the unaided eye on the external surface of the pipe.

**1.6.5** The drift expanding test consists of expanding a section of pipe between 30 mm and 50 mm in length until the external diameter is increased by 20% (15% for half-hard pipes), at ambient temperature, by means of a tapered pin having a 45° included angle.

No cracking or rupture is to be visible to the unaided eye after completion of tests.

## 1.7 Stress corrosion cracking test

**1.7.1** The stress corrosion test (Hg-nitrate test) is designed to reveal the presence of residual stresses which could lead to stress corrosion cracks.

The test consists of immersing for 30 minutes a 150 mm specimen in a water solution with the required Hg-nitrate concentration after proper cleaning.

The water solution is to contain 10gr of mercurous nitrate and 10 cm<sup>3</sup> of nitric acid (specific gravity 1,41) per litre of solution. The specimen is then to be immediately washed, rinsed and inspected.

No signs of cracking are to appear within eight days following the immersion.

**1.7.2** The test may be carried out in accordance with an acceptable national standard using a mercurous nitrate solution.

**1.7.3** Should any specimen fail to meet the requirements of this test, then all tubes represented by that specimen are to be rejected but may be resubmitted after a stress relieving treatment.

## 1.8 Hydrostatic test - Eddy current test

**1.8.1** All pipes are to be tested to a pressure equal to 1,5 times their design service pressure without exceeding 6,90 MPa (70 bar), unless otherwise specified.

**1.8.2** If the service pressure is unknown at the time of the hydrostatic test, a test pressure calculated according to the following formula may be applied:

$$P = \frac{0,5 \cdot t \cdot R_m}{D}$$

P : Test pressure, in MPa (to be multiplied by 10,2 to obtain the value in bar)

t : Nominal wall thickness, in mm

D : Nominal outside diameter, in mm

$R_m$  : Minimum guaranteed tensile strength, in N/mm<sup>2</sup>, according to Tab 2.

**1.8.3** The test pressure is to be maintained for sufficient time to permit proof and inspection. There is to be no evidence of leakage or sweating.

**1.8.4** An Eddy current test may be accepted in lieu of the hydrostatic test.

**1.8.5** The Eddy current testing facilities are to be submitted to special approval with particular attention to the calibrating conditions of the equipment used; it is to be demonstrated that testing with Eddy currents as proposed is at least as rigorous as the hydrostatic test.

**1.8.6** The Surveyor may need to check that the equipment used is calibrated.

**1.8.7** Unless otherwise agreed, the Manufacturer's certificate of satisfactory hydraulic or Eddy current testing will be accepted.

### 1.9 Visual and non-destructive examination

**1.9.1** The Manufacturer is to prepare a report relative to the inspection and verification of dimensions of all of the tubes presented.

The dimensional tolerances (diameter, thickness) are to comply with applicable national standards.

**1.9.2** The Surveyor may require that all pipes are presented for visual examination and verification of dimensions.

Internal and external surfaces of pipes are to have a clean and smooth finish, and be free from harmful defects.

The Manufacturer is to provide adequate equipment to enable an internal and external examination of the pipes to be carried out.

### 1.10 Rectification of defects

**1.10.1** Small surface imperfections may be removed by grinding provided that the thickness of the pipe after grinding and dressing is not less than the required minimum thickness. The dressed areas are to be blended into the contour of the tube with very large radius fillets.

**1.10.2** Repair of defects by welding is not permitted; thus any defects which cannot be removed by grinding will necessarily lead to the rejection of the pipe.

### 1.11 Identification and marking

**1.11.1** All pipes and tubes are to be identified and marked in conformity with the requirements of Ch 1, Sec 1, [4.1.3]. The following additional details are to be shown on all materials which have been accepted:

- a) Manufacturer's name or trade mark
- b) grade of material or designation code.

**1.11.2** Identification is to be by rubber stamp or stencils. Hard stamping is not permitted.

## CHAPTER 9 ALUMINIUM ALLOYS

---

- Section 1      General Requirements
- Section 2      Wrought Aluminium Alloy Products (Plates, Bars, Sections and Tubes)
- Section 3      Rivets
- Section 4      Transition Joints
- Section 5      Aluminium Alloy Castings

# Section 1 General Requirements

## 1 Scope

### 1.1 General

1.1.1 The requirements of this Chapter apply to wrought aluminium alloys, rivets, transition joints and cast aluminium alloys.

### 1.2 Other standards

1.2.1 Alloys and tempers other than those defined in Sec 2, Sec 3, Sec 4 and Sec 5, complying with national or international standards or proprietary specifications may be considered by the Society further to detailed study of their properties and their weldability.

## 2 Manufacturing

### 2.1 Alloy making and heat treatment processes

2.1.1 Manufacturing processes and heat treatments suitable to obtain products having the specified quality and properties are, in principle, left to the discretion of the Manufacturer.

### 2.2 Quality of material

2.2.1 All products are to be free from internal and surface defects prejudicial to the use of the concerned material for the intended application.

Reference is made to the general provisions given in Ch 1, Sec 1, [3.6] for visual, dimensional and non destructive examination.

### 2.3 Marking

2.3.1 Products are to be clearly marked by the Manufacturer in accordance with the requirements of Chapter 1.

The following details are to be shown on all materials which have been accepted:

- Manufacturer's mark
- grade of alloy and temper condition
- number of the manufacturing batch enabling the manufacturing process to be traced back
- Classification Society's brand.

When extruded products are bundled together or packed in crates for delivery, the marking is to be affixed by a securely fastened tag or label.

### 2.4 Certification and documentation

2.4.1 For each tested batch, the manufacturer is to supply to the Surveyor a test certificate or shipping statement containing the following details:

- purchaser and order number
- construction project number, when known
- number, dimensions and weight of the product
- designation of the aluminium alloy (grade) and of its temper condition (delivery heat treatment)
- identification mark or manufacturing batch number
- chemical composition
- test results.

Where the alloy is not produced at the works at which it is wrought, a certificate is to be supplied by the Manufacturer of the alloy stating the cast number and chemical composition.

# Section 2 Wrought Aluminium Alloy Products (Plates, Bars, Sections and Tubes)

## 1 Requirements

### 1.1 Scope

**1.1.1** The requirements of this Section apply to wrought aluminium alloys used in the construction of hulls, superstructures and other marine structures.

**1.1.2** These requirements are applicable to wrought aluminium products within a thickness range between 3 mm and 50 mm inclusive.

**1.1.3** The application of these provisions to aluminium alloy products outside this thickness range requires the prior agreement of the Society.

The general requirements specified in Sec 1 are also to be complied with, as appropriate.

**1.1.4** In the case of applications involving the storage and transport of liquefied gases, reference is to be made to Society's Rules for the Classification of Steel Ships, NR467, Part D, Chapter 9, and, to the International Code for the Construction and Equipment of Ships Carrying Liquefied Gases in Bulk (IGC Code).

For gas fuelled ships, reference is to be made to Society Rule Note NR529, and, to the International Code of Safety for Ships using Gases or other Low-flash point Fuels (IGF Code).

Materials intended for the construction of cargo tanks or storage tanks for liquefied gases and for other low temperature applications are in general to be manufactured in 5083 alloy in the annealed condition.

**1.1.5** The numerical designation (grade) of aluminium alloys and their temper designation are based on those of the Aluminium Association.

Temper conditions (delivery heat treatment) are defined in the European standard EN 515:2017 or ANSI H35.1:2017.

### 1.2 Approval

**1.2.1** All materials, including semi-finished products, are to be manufactured at works which are approved by the Society for the grades of aluminium alloy supplied.

### 1.3 Aluminium grades and their temper conditions

#### 1.3.1 Rolled products (sheets, strips and plates)

The following aluminium alloys are covered by these requirements:

- 5083
- 5086
- 5383
- 5059
- 5754
- 5456

with the hereunder temper conditions:

- O, H111, H112
- H116
- H321

#### 1.3.2 Extruded products (sections, shapes, bars and closed profiles)

The following aluminium alloys are covered by these requirements:

- 5083
- 5086
- 5383
- 5059

with the hereunder temper conditions:

- O, H111, H112

and

- 6005A
- 6061
- 6082

with the hereunder temper conditions:

- T5 or T6

**1.3.3** The alloy grades 6005A and 6061 of the 6000 series are not to be used in direct contact with sea water unless protected by anodes and/or a paint system.

**1.4 Chemical composition**

**1.4.1** The Manufacturer is to determine the chemical composition of each cast. Product analysis is to be made where the final product chemistry is not well represented by the analysis from the cast.

**1.4.2** The chemical composition of aluminium alloys is to comply with the requirements given in Tab 1.

The Manufacturer’s declared analysis is accepted subject to occasional checks if required by the Surveyor.

**1.4.3** When the aluminium alloys are not cast in the same works in which they are manufactured into semi-finished products, the Surveyor is to be given a certificate issued by the works in question which indicates the reference numbers and chemical composition of the heats.

**1.5 Mechanical properties**

**1.5.1** Mechanical properties are to comply with the requirements given in Tab 2 and Tab 3.

Mechanical properties of the welded joint are lower for strain hardened or heat treated alloys, when compared with those of the base material in general. Reference is to be made to the applicable requirements for approval of welding consumables (see Ch 11, Sec 15) welding procedures (see Ch 12, Sec 5).

**1.6 Repairs**

**1.6.1** Slight surface imperfections may be removed by smooth grinding or machining as long as the thickness of the material remains within the tolerances given in [1.7].

**1.7 Tolerances on dimensions**

**1.7.1** The underthickness tolerances for rolled products given in Tab 4 are minimum requirements.

The underthickness tolerances for extruded products are to be in accordance with the requirements of recognized national or international standards.

Dimensional tolerances other than underthickness tolerances are to comply with a recognized national or international standard.

**Table 1 : Chemical composition**

Grade	Si	Fe	Cu	Mn	Mg	Cr	Zn	Ti	Other elements (1)	
									Each	Total
5083	0,40	0,40	0,10	0,40-1,00	4,00-4,90	0,05-0,25	0,25	0,15	0,05	0,15
5383	0,25	0,25	0,20	0,70-1,00	4,00-5,20	0,25	0,40	0,15	0,05 (4)	0,15 (4)
5059	0,45	0,50	0,25	0,60-1,20	5,00-6,00	0,25	0,40-0,90	0,20	0,05 (5)	0,15 (5)
5086	0,40	0,50	0,10	0,20-0,70	3,50-4,50	0,05-0,25	0,25	0,15	0,05	0,15
5754	0,40	0,40	0,10	0,50 (2)	2,60-3,60	0,30 (2)	0,20	0,15	0,05	0,15
5456	0,25	0,40	0,10	0,50-1,00	4,70-5,50	0,05-0,20	0,25	0,20	0,05	0,15
6005-A	0,50-0,90	0,35	0,30	0,50 (3)	0,40-0,70	0,30 (3)	0,20	0,10	0,05	0,15
6061	0,40-0,80	0,70	0,15-0,40	0,15	0,80-1,20	0,04-0,35	0,25	0,15	0,05	0,15
6082	0,70-1,30	0,50	0,10	0,40-1,00	0,60-1,20	0,25	0,20	0,10	0,05	0,15

**Note 1:** Composition in percentage mass by mass maximum unless shown as a range or as a minimum.  
 (1) Includes Ni, Ga, V and listed elements for which no specific limit is shown. Regular analysis need not be made.  
 (2) Mn + Cr: 0,10-0,60  
 (3) Mn + Cr: 0,12-0,50  
 (4) Zr: maximum 0,20. The total for other elements does not include Zirconium.  
 (5) Zr: 0,05-0,25. The total for other elements does not include Zirconium.



**Table 2 : Mechanical properties for rolled products with 3 mm ≤ t ≤ 50 mm**

Grade	Temper condition	Thickness t (mm)	Yield strength R <sub>p0,2</sub> min (N/mm <sup>2</sup> )	Tensile strength R <sub>m</sub> min or range (N/mm <sup>2</sup> )	Elongation min (%) <b>(1)</b>	
					A <sub>50 mm</sub>	A <sub>5d</sub>
5083	O	3 ≤ t ≤ 50	125	275 - 350	16	14
	H111	3 ≤ t ≤ 50	125	275 - 350	16	14
	H112	3 ≤ t ≤ 50	125	275	12	10
	H116	3 ≤ t ≤ 50	215	305	10	10
	H321	3 ≤ t ≤ 50	215 - 295	305 - 385	12	10
5383	O	3 ≤ t ≤ 50	145	290		17
	H111	3 ≤ t ≤ 50	145	290		17
	H116	3 ≤ t ≤ 50	220	305	10	10
	H321	3 ≤ t ≤ 50	220	305	10	10
5059	O	3 ≤ t ≤ 50	160	330		24
	H111	3 ≤ t ≤ 50	160	330	24	24
	H116	3 ≤ t ≤ 20	270	370	10	10
		20 < t ≤ 50	260	360	10	10
	H321	3 ≤ t ≤ 20	270	370	10	10
		20 < t ≤ 50	260	360	10	10
5086	O	3 ≤ t ≤ 50	95	240 - 305	16	14
	H111	3 ≤ t ≤ 50	95	240 - 305	16	14
	H112	3 ≤ t ≤ 12,5	125	250	8	
		12,5 < t ≤ 50	105	240		9
H116	3 ≤ t ≤ 50	195	275	10 <b>(2)</b>	9	
5754	O	3 ≤ t ≤ 50	80	190 - 240	18	17
	H111	3 ≤ t ≤ 50	80	190 - 240	18	17
5456	O	3 ≤ t ≤ 6,3	130 - 205	290 - 365	16	
		6,3 < t ≤ 50	125 - 205	285 - 360	16	14
	H116	3 ≤ t ≤ 30	230	315	10	10
		30 < t ≤ 40	215	305		10
		40 < t ≤ 50	200	285		10
	H321	3 ≤ t ≤ 12,5	230 - 315	315 - 405	12	
		12,5 < t ≤ 40	215 - 305	305 - 385		10
40 < t ≤ 50		200 - 295	285 - 370		10	

**(1)** Elongation in 50 mm applies for thicknesses up to and including 12,5 mm and in 5d for thicknesses over 12,5 mm.  
**(2)** 8% for thicknesses up to and including 6,3 mm.

**1.8 Tests and examinations**

**1.8.1 Visual and non-destructive examination**

In general, the non-destructive examination of material is not required for acceptance purposes.

Unless otherwise agreed, the following products are to be submitted to the Surveyor for visual examination:

- plates for the construction of cargo tanks, secondary barriers and process pressure vessels
- pressure pipes.

**1.8.2 Dimensions**

It is the manufacturer’s responsibility to check the materials for compliance with the dimensions and tolerances.

**Table 3 : Mechanical properties for extruded products with  $3 \text{ mm} \leq t \leq 50 \text{ mm}$**

Grade	Temper condition	Thickness t (mm)	Yield strength $R_{p0,2}$ min (N/mm <sup>2</sup> )	Tensile strength $R_m$ min or range (N/mm <sup>2</sup> )	Elongation min (%) (1) (2)	
					$A_{50mm}$	$A_{5d}$
5083	O	$3 \leq t \leq 50$	110	270 - 350	14	12
	H111	$3 \leq t \leq 50$	165	275	12	10
	H112	$3 \leq t \leq 50$	110	270	12	10
5383	O	$3 \leq t \leq 50$	145	290	17	17
	H111	$3 \leq t \leq 50$	145	290	17	17
	H112	$3 \leq t \leq 50$	190	310		13
5059	H112	$3 \leq t \leq 50$	200	330		10
5086	O	$3 \leq t \leq 50$	95	240 - 315	14	12
	H111	$3 \leq t \leq 50$	145	250	12	10
	H112	$3 \leq t \leq 50$	95	240	12	10
6005A	T5	$3 \leq t \leq 50$	215	260	9	8
	T6	$3 \leq t \leq 10$	215	260	8	6
		$10 < t \leq 50$	200	250	8	6
6061	T6	$3 \leq t \leq 50$	240	260	10	8
6082	T5	$3 \leq t \leq 50$	230	270	8	6
	T6	$3 \leq t \leq 5$	250	290	6	
		$5 < t \leq 50$	260	310	10	8

(1) The values are applicable for longitudinal and transverse tensile test specimens as well.

(2) Elongation in 50 mm applies for thicknesses up to and including 12,5 mm and in 5d for thicknesses over 12,5 mm.

**Table 4 : Under thickness tolerances for rolled products**

Nominal thickness (mm)	Thickness tolerances for nominal width (mm)		
	up to 1500	from 1500 to 2000	from 2000 to 3500
from 3 to 4	0,10	0,15	0,15
from 4 to 8	0,20	0,20	0,25
from 8 to 12	0,25	0,25	0,25
from 12 to 20	0,35	0,40	0,50
from 20 to 50	0,45	0,50	0,65

### 1.8.3 Batch composition

Each batch is made up of products:

- of the same alloy grade and from the same cast
- of the same product form and similar dimensions (for plates, the same thickness)
- manufactured by the same process
- having been submitted simultaneously to the same temper condition.

### 1.8.4 Sampling

Tests samples are to be taken:

- at one third of the width from a longitudinal edge of rolled products
- in the range from 1/3 to 1/2 of the distance from the edge to the centre of the thickest part of extruded products.

Test samples are to be taken so that the orientation of test specimens is as follows:

- Rolled products (plates, sheets)

Normally, tests in the transverse direction are required. If the width is insufficient to obtain transverse test specimens, or in the case of strain hardening alloys, tests in the longitudinal direction are permitted.

- Extruded products

Extruded products or extruded drawn materials (pipes, bars, miscellaneous sections) are tested in the longitudinal direction. After removal of test samples, each test specimen is to be marked so that its original identity, location and orientation are maintained.



### 1.8.5 Tensile tests

The requirements are detailed in [1.9].

### 1.8.6 Corrosion tests

The requirements are detailed in [1.11].

### 1.8.7 Verification of proper fusion of press welds for closed profiles

The manufacturer has to demonstrate by macrosection tests or drift expansion tests (see [1.10]) of closed profiles that there is no lack of fusion at the press weld.

Every fifth profile is to be sampled after heat treatment. One profile is to be sampled from batches of five profiles or less.

Profiles with length exceeding 6m is to be sampled every profile in the start of the production. The number of tests may be reduced to every fifth profile if the results from the first 3-5 profiles are found acceptable.

Each profile sampled will have two samples cut from the front and back end of the production profile.

## 1.9 Tensile test

### 1.9.1 General

The test specimens and procedures are to be in accordance with Ch 2, Sec 2.

### 1.9.2 Number of tensile test specimens

#### a) Rolled products

One tensile test specimen is to be taken from each batch of the product. If the weight of one batch exceeds 2000 kg, one extra tensile test specimen is to be taken from every 2000 kg of the product or fraction thereof, in each batch. For single plates or for coils weighing more than 2000 kg each, only one tensile test specimen per plate or coil is to be taken.

For plates to be used in the construction of cargo tanks, secondary barriers and process pressure vessels with design temperatures below  $-55^{\circ}\text{C}$ , one tensile test specimen is to be taken from each plate.

#### b) Extruded products

For the products with a nominal weight of less than 1 kg/m, one tensile test specimen is to be taken from each 1000 kg, or fraction thereof, in each batch. For nominal weights between 1 and 5 kg/m, one tensile test is to be taken from each 2000 kg or fraction thereof, in each batch. If the nominal weight exceeds 5 kg/m, one tensile test specimen is to be taken for each 3000 kg of the product or fraction thereof, in each batch.

For pipes, one test sample from each batch is to be taken.

Batches are to be made up of no more than 50 pipes of the same diameter and wall thickness, manufactured from the same cast with the same final condition or heat treatment.

At the discretion of the Surveyor, pipes having slightly different diameters and/or thicknesses may be included in the same batch.

### 1.9.3 Location of tensile test specimen

The location of test specimens is to be in accordance with Ch 2, Sec 2.

## 1.10 Drift expansion tests

### 1.10.1 General

When required (see [1.8.7]), the tests are to be carried out in accordance with the requirements of this Section.

### 1.10.2 Test specimens

The test specimens are to be cut with the ends perpendicular to the axis of the profile. The edges of the end may be rounded by filing.

The specimen is to be in accordance with Ch 2, Sec 6, [2].

### 1.10.3 Test procedure

The test is to be carried out at ambient temperature. The test procedure is to be in accordance with Ch 2, Sec 6, [2] with a mandrel angle of at least  $60^{\circ}$ .

### 1.10.4 Test result

The sample is considered to be unacceptable if the sample fails with a clean split along the weld line which confirms lack of fusion.

## 1.11 Corrosion tests

**1.11.1** Rolled 5xxx alloys of type 5083, 5383, 5059, 5086 and 5456 in the H116 and H321 tempers intended for use in marine hull construction or in marine applications where frequent direct contact with seawater is expected are to be corrosion tested with respect to exfoliation and intergranular corrosion resistance.

**1.11.2** The manufacturers have to establish the relationship between microstructure and resistance to corrosion when the above alloys are approved. A reference photomicrograph taken at 500x, under the conditions specified in ASTM B928:2015 Section 9.4.1, is to be established for each of the alloy tempers and thickness ranges relevant. The reference photographs are to be taken from samples which have exhibited no evidence of exfoliation corrosion at a pitting ration of PB or better, when subjected to the test described in ASTM G66:2018 (ASSET). The samples are also to have exhibited resistance to intergranular corrosion at a mass loss not greater than 15 mg/cm<sup>2</sup>, when subjected to the test described in ASTM G67:2018 (NAMLT). Upon satisfactory establishment of the relationship between microstructure and resistance to corrosion, the master photomicrographs and the results of the corrosion tests are to be submitted to the Society for approval.

The manufacturer is responsible to maintain the production practices unchanged after approval of the reference micrographs. Other test methods may also be accepted at the discretion of the Society.

**1.11.3** For batch acceptance of 5xxx alloys in the H116 and H321 tempers, metallographic examination of one sample selected from mid width at one end of a coil or random sheet or plate is to be carried out.

A longitudinal section perpendicular to the rolled surface is to be prepared for metallographic examination, under the conditions specified in ASTM B928:2015 Section 9.6.1.

The microstructure of the sample is to be compared to the reference photomicrograph of acceptable material in the presence of the Surveyor. If the microstructure shows evidence of continuous grain boundary network of aluminium-magnesium precipitate in excess of the reference photomicrographs of acceptable material, the batch is either to be rejected or tested for exfoliation-corrosion resistance subject to the agreement of the Surveyor. In that case, the corrosion tests are to be in accordance with ASTM G6:2018 and G67:2018 or equivalent standards. If the results from testing satisfy the acceptance criteria stated in [1.11.2]

As an alternative to metallographic examination, each batch may be tested for exfoliation-corrosion resistance and intergranular corrosion resistance, in accordance with ASTM G66:2018 and ASTM G67:2015 under the conditions specified in ASTM B928:2015 or equivalent standards accepted by the Society.

**1.11.4** When the products have been tested with satisfactory results in accordance with this Section, the mark "M" is to be added after the temper condition e.g. 5083 H321 M for subsequent reporting and marking (see Sec 1, [2.3.1] and Sec 1, [2.4.1]).

### 1.12 Re-test procedures

**1.12.1** When the tensile test from the first piece selected in accordance with [1.9.2] fails to meet the requirements, two further tensile tests may be made from the same piece. If both of these additional tests are satisfactory, this piece and the remaining pieces from the same batch may be accepted.

**1.12.2** If one or both of the additional tests referred to in [1.12.1] is/are unsatisfactory, the piece is to be rejected, but the remaining material from the same batch may be accepted, provided that two of the remaining pieces in the batch selected in the same way are tested with satisfactory results.

If unsatisfactory results are obtained from either of these two pieces, then the batch of material is rejected.

**1.12.3** In the event of any material bearing the Society's brand failing to comply with the test requirements, the brand is to be unmistakably defaced by the Manufacturer.

### 1.13 Hydrostatic test

**1.13.1** Pipes intended for pressure parts are to be subjected to hydrostatic testing.

Unless otherwise required, the test pressure is to be at least 1,5 times the maximum working pressure.

## Section 3 Rivets

### 1 Requirements

#### 1.1 Scope

1.1.1 The requirements of this Section apply to aluminium alloy rivets intended for use in the construction of marine structures.

#### 1.2 Chemical composition

1.2.1 For rivets or rivet bars which are made up of magnesium alloys, the magnesium content is not to exceed a maximum of 3,9%.

In particular, the chemical composition of bars used for the manufacture of rivets is to comply with the requirements of Tab 1.

**Table 1 : Chemical composition, percentage**

Element	5154A	6082
Copper	0,10 max.	0,10 max.
Magnesium	3,10 - 3,90	0,60 - 1,20
Silicon	0,50 max.	0,70 - 1,30
Iron	0,50 max.	0,50 max.
Manganese	0,10 - 0,50	0,40 - 1,00
Zinc	0,20 max.	0,20 max.
Chromium	0,25 max.	0,25 max.
Titanium	0,20 max.	0,10 max.
Other elements:		
each	0,05 max.	0,05 max.
total	0,15 max.	0,15 max.
Aluminium	remainder	remainder

#### 1.3 Heat treatment

1.3.1 Rivets are to be supplied in the following conditions:

5154A - annealed

6082 - solution treated.

#### 1.4 Test material

1.4.1 Bars intended for the manufacture of rivets are to be presented for testing in batches of no more than 250 kg.

The material in each batch is to be of the same alloy, manufacturing process and final heat treatment and have the same or a comparable diameter. One test sample is to be taken from each batch and, prior to testing, heat treated in full cross-section and in a manner simulating the heat treatment applied to the finished rivets.

#### 1.5 Mechanical tests

1.5.1 At least one tensile specimen and one flattening test specimen are to be prepared from each test sample.

1.5.2 The tensile test specimen is to be a short length of bar having the original diameter of the product.

1.5.3 The flattening test consists of compressing the specimen between two rigid and parallel flat plates in a direction perpendicular to its longitudinal axis; the plates are to cover the whole specimen after flattening.

The flattening test specimen is to consist of a full section of bar having the original diameter of the product and a length of 1,5 times the diameter cut from the bar.

The test is to be continued until the distance between the two plates, measured under load, reaches a value corresponding to one half of the original length of the specimen.

The test is to be performed at ambient temperature.

The result of the test is satisfactory if, after compression, the specimen is free from cracks.

1.5.4 The results of tensile tests are to comply with the appropriate requirements of Tab 2.

**Table 2 : Mechanical properties**

Mechanical properties	5154A	6082
0,2% proof stress (N/mm <sup>2</sup> ) min	90	120
Tensile strength (N/mm <sup>2</sup> ) min	220	190
Elongation (%) on 5, 65 $\sqrt{S}$ omin	18	16

**1.5.5** At least three samples are to be selected from each consignment of manufactured rivets. Flattening tests as detailed in [1.5.3] are to be carried out on each sample.

## **1.6 Identification**

**1.6.1** Each package of manufactured rivets is to be identified with attached labels giving the following details:

- a) Manufacturer's name or trade mark
- b) alloy grade
- c) rivet size.

## **1.7 Certification**

**1.7.1** The test certificate for each consignment of manufactured rivets is to include the following particulars:

- a) purchaser's name and order number
- b) description and dimensions
- c) specification of the alloy.

## Section 4 Transition Joints

### 1 Requirements

#### 1.1 Scope

**1.1.1** The requirements of this Section apply to explosion bonded composite aluminium/steel transition joints used for the connection of aluminium structures to steel plating.

#### 1.2 Manufacturing

**1.2.1** Transition joints are to be manufactured at works which are approved by the Society. The specification of the Manufacturer is to be submitted for approval. The maximum temperature allowable at the interface during welding is to be indicated; approval tests are required.

**1.2.2** The aluminium material is to comply with the requirements of Sec 2 and the steel is to be of an appropriate grade complying with the requirements of Chapter 3.

#### 1.3 Visual and non-destructive examination

**1.3.1** Each composite plate is to be subjected to visual of all surfaces and full ultrasonic examination in accordance with a recognised standard accepted by the Society to determine the extent of any unbonded areas. The latter are unacceptable and any such area plus 25 mm of surrounding sound material is to be discarded.

#### 1.4 Testing

**1.4.1** The series of tests includes, from each end of one plate in a batch of three plates:

- one through thickness tensile test
- one shear test
- one bend test.

**1.4.2** Tests are made on specimens equivalent to those specified at the approval.

The results of these tests are to comply with the requirements of the manufacturing specification.

# Section 5 Aluminium Alloy Castings

## 1 Requirements

### 1.1 Scope

**1.1.1** The requirements of this Section apply to aluminium alloy castings used in the construction of hulls and other marine structures, and for cryogenic applications where the design temperature is not lower than  $-165^{\circ}\text{C}$ .

### 1.2 Aluminium grades

**1.2.1** Alloy castings may be manufactured with magnesium, silicon or magnesium-silicon alloys as follows:

- a) magnesium alloys:  
Al-Mg 3 and Al-Mg 6
- b) silicon alloys:  
Al-Si 12
- c) magnesium-silicon alloys:  
Al-Si 7 Mg 0,3;  
Al-Si 7 Mg 0,6;  
Al-Si 10 Mg;  
and possibly: Al-Si 2 Mg.

**1.2.2** Alloys Al-Mg 3, Al-Mg 6 and Al-Si 12 are not generally submitted to heat treatment after casting; this is not the case for magnesium-silicon alloys which may undergo such treatment.

**1.2.3** The use of other alloys or of alloys which have been submitted to a specific heat treatment is subject to the Society's agreement.

### 1.3 Manufacturing

#### 1.3.1 Approval

Manufacturers of alloy castings are to be recognised by the Society in accordance with NR320.

Manufacturing process of alloy castings is to be approved as per NR480 "Approval of the manufacturing process of metallic materials".

#### 1.3.2 Quality of castings

All castings are to be free from surface or internal defects which would be prejudicial to their proper application in service.

#### 1.3.3 Visual examination

All castings are to be cleaned and adequately prepared for inspection.

The visual examination and verification of dimensions are the responsibility of the Manufacturer, unless otherwise agreed.

Before acceptance, all castings are to be presented to the Surveyor for visual examination, unless otherwise agreed.

#### 1.3.4 Non-destructive tests

If non-destructive tests are required, the procedures are to be submitted by the Society.

#### 1.3.5 Repairs

At the discretion of the Surveyor, small surface defects may be removed by grinding.

Where repairs by welding are necessary, the welding procedure is to be preliminarily approved by the Society and qualification tests may be required.

The agreed repairs are then to be surveyed as required.

#### 1.3.6 Pressure testing

Where required by the relevant construction Rules, casting are to be pressure tested before final acceptance.

Unless otherwise agreed, these tests are to be carried out in the presence and to the satisfaction of the Surveyor.

## 1.4 Chemical composition

**1.4.1** The chemical composition of aluminium alloys used to manufacture castings is given in Tab 1 and the relevant certificate is to be provided by the producer.

**Table 1 : Aluminium alloy castings - Chemical composition (see Note 1)**

Designation ISO		Si (%)	Fe (%)	Cu (%)	Mn (%)	Mg (%)	Ni (%)	Zn (%)	Pb (%)	Sn (%)	Ti (%)	Others (%) each total	
Al-Mg 3	Min.					2,50					0,05		
	Max.	0,50	0,50	0,10	0,50	3,50	0,05	0,20	0,05	0,05	0,25	0,05	0,15
Al-Mg 6 (1)	Min.					5,00							
	Max.	0,40	0,50	0,10	0,50	7,00	0,05	0,20	0,05	0,05	0,20	0,05	0,15
Al-Si 2 Mg	Min.	1,60			0,30	0,45					0,05		
	Max.	2,40	0,60	0,10	0,50	0,65	0,05	0,10	0,05	0,05	0,20	0,05	0,15
Al-Si 7 Mg (2)	Min.	6,50				0,20					0,05		
	Max.	7,50	0,55	0,15	0,50	0,40	0,05	0,10	0,05	0,05	0,25	0,05	0,15
Al Si 7 Mg 0,3 (2)	Min.	6,50				0,25					0,08		
	Max.	7,50	0,20	0,10	0,10	0,40	0,05	0,10	0,05	0,05	0,25	0,03	0,10
Al Si 7 Mg 0,6 (2)	Min.	6,50				0,45					0,08		
	Max.	7,50	0,20	0,10	0,10	0,70	0,05	0,10	0,05	0,05	0,25	0,03	0,10
Al Si 10 Mg (2)	Min.	9,00				0,17							
	Max.	11,00	0,60	0,10	0,50	0,40	0,05	0,10	0,05	0,05	0,20	0,05	0,15
Al Si 12 (2)	Min.	11,00											
	Max.	13,50	0,70	0,10	0,50	0,10	0,05	0,15	0,05	0,05	0,15	0,05	0,15

(1) This alloy may contain less than 0,04% of beryllium, which is not to be considered as an impurity.  
(2) These alloys may contain elements necessary to the eutectic modification with contents of less than 0,20%, which are not to be considered as impurities.  
**Note 1:** Small variations in the contents of some elements in comparison to the values mentioned in this Table are possible in agreement with the Society.

## 1.5 Mechanical properties

1.5.1 The mechanical properties are given in Tab 2.

1.5.2 The mechanical properties given in Tab 2 correspond to the non-heat treated condition. However, the test pieces may be heat-treated.

In the case of heat treatment, test samples are to be treated in the same way and, as a rule, together with the material they represent.

Generally, only tensile strength and elongation values are rule requirements; the values of yield stress are given for information.

## 1.6 Mechanical tests

1.6.1 At least one tensile specimen is to be tested from each batch.

Batches are to have a total mass not exceeding 500kg and be made up of pieces having the same or comparable shape and dimensions, manufactured from the same cast with the same condition of heat treatment.

The number of pieces in each batch is not to exceed 25 in the case of castings for pistons and for pressure parts or pieces of considerable importance; a greater number may be accepted for small pieces, to the Surveyor's satisfaction.

The homogeneity of batches of aluminium alloy castings may be checked by means of a Brinell type hardness test when small castings manufactured in large quantities are concerned.

1.6.2 The test samples are to be separately cast in moulds made from the same type of material as used for the castings. These moulds are to conform to national standards, as appropriate.

1.6.3 The method and procedures for the identification of the test specimens, and the casting they represent, are to be agreed with the Surveyor. The identification marks are to be maintained during the preparation of test specimens.

1.6.4 Where the results of a test do not comply with the requirements, the re-test procedure detailed in Ch 1, Sec 1, [3.5] is to be applied. When castings are to be used in the heat treated condition, the re-test sample is also to be heat treated together with the castings it represents.

**Table 2 : Aluminium alloy casting - Mechanical characteristics**

Designation ISO (3)	Guaranteed minimum values			
	Minimum tensile strength R (N/mm <sup>2</sup> )	Minimum yield stress R <sub>e0,2</sub> (N/mm <sup>2</sup> ) (1)	Elongation A (%) on 5,65√S <sub>0</sub>	Brinell Hardness HB (2)
Al Mg 3-F	170	70	7,0	60
Al Mg 6-F	180	100	4,0	65
Al Si 2 Mg-F	170	70	5,0	50
Al Si 7 Mg-F	170	80	4,0	55
Al Si 7 Mg 0,3-T6	250	180	4,0	75
Al Si 7 Mg 0,6-T6	290	210	4,0	90
Al Si 10 Mg-F	170	90	4,0	55
Al Si 10 Mg-T6	250	180	1,5	80
Al Si 12-F	170	75	5,0	55

(1) For information only.  
 (2) Minimum hardness which can be specified for heat treated elements.  
 (3) F = as cast.  
 T6 = quenched and tempered.



## **CHAPTER 10**

# **EQUIPMENT FOR MOORING AND ANCHORING**

---

- Section 1      Anchors for Ships
- Section 2      Stud Link Chain Cables and Accessories for Ships
- Section 3      Studless Chain Cables for Ships
- Section 4      Offshore Mooring Chain Cables and Accessories
- Section 5      Steel Wire Ropes
- Section 6      Fibre Ropes

# Section 1 Anchors for Ships

## 1 Requirements

### 1.1 Scope

#### 1.1.1 General

The requirements of this Section apply to anchors and associated components for ships (heads, shanks and shackles) produced from cast or forged steel, or fabricated by welding of rolled steel plate and bars.

#### 1.1.2 Types of anchors

The types of anchors covered include:

- ordinary anchors (stockless and stocked anchors)
- high holding power (HHP) anchors
- very high holding power anchors (VHHP) anchors not exceeding 1500 kg in mass.

Any changes to the design made during manufacture are to have prior written agreement from the Society.

#### 1.1.3 Modified testing procedure

For anchors having mass lower than 100 kg, or 75 kg in the case of high holding power anchors, continuously produced by Manufacturers who have been approved by the Society for this purpose, a batch testing procedure may be accepted.

The composition of the batches is to be agreed with the Society with regards to the homogeneity of material, manufacturing, heat treatment and dimensions.

### 1.2 Design

**1.2.1** Drawings of ordinary anchors are to be submitted to the Society for review.

Type approval according to procedures agreed with the Society is required for high and very high holding power anchors as per Rules for the Classification of Steel Ships (NR467).

**1.2.2** The mass of anchors and the percentage of the mass of components in relation to the total mass are to be as required in the various parts of the Rules relevant to the equipment.

### 1.3 Materials

#### 1.3.1 Materials for anchors

All anchors are to be manufactured from materials meeting the requirements of these Rules as indicated in the following:

- cast steel anchor flukes, shanks, swivels and shackles are to be manufactured and tested in accordance with the requirements of Chapter 6 and are to comply with the requirements for castings for welded construction. The steel is to be fine grain treated with aluminium. Charpy V-notch impact testing is required when drop tests and hammering tests are not carried out (see [1.5.3]). For the manufacture of swivels, the use of other grades of steel is subject to special consideration by the Society
- forged steel anchor pins, shanks, swivels and shackles are to be manufactured and tested in accordance with Chapter 5. Shanks, swivels and shackles are to comply with the requirements for carbon and carbon-manganese steels for welded construction. For the manufacture of swivels, the use of other grades of steel is subject to special consideration by the Society
- rolled billets, plate and bar for fabricated steel anchors are to be manufactured and tested in accordance with the requirements of Chapter 3
- rolled bar intended for pins, swivels and shackles are to be manufactured and tested in accordance with the requirements of Chapter 3 or Chapter 5 as applicable.

#### 1.3.2 Materials for VHHP anchors

In addition to the requirements of [1.3.1], the following applies:

- rolled plate and bars in welded VHHP are to be selected in accordance with the requirements given in Tab 1
- material for shackles is to be Charpy V-notch impact tested with an energy average not less than 60 J at 0°C
- cast steel used for VHHP anchors is to be Charpy V-notch impact tested with an energy average not less than 27 J at 0°C.

**Table 1 : Material grade for VHHP anchors**

Gross thickness, in mm	Normal strength steel	Higher strength steel
$t \leq 15$	A	AH
$15 < t \leq 20$	A	AH
$20 < t \leq 25$	B	AH
$25 < t \leq 30$	D	DH
$30 < t \leq 35$	D	DH
$35 < t \leq 40$	D	DH
$40 < t \leq 50$	E	EH

**1.4 Manufacturing**

**1.4.1 Tolerances**

If not otherwise specified on standards or on drawings demonstrated to be appropriate and accepted by the Society, the following assembly and fitting tolerance are to be applied.

The clearance either side of the shank within the shackle jaws should be no more than 3mm for anchors up to 3 tonnes weight, 4 mm for anchors up to 5 tonnes weight, 6mm for anchors up to 7 tonnes weight and should not exceed 12 mm for larger anchors.

The shackle pin should be a push fit in the eyes of the shackles, which are to be chamfered on the outside to ensure a good tightness when the pin is clenched over on fitting. The shackle pin to hole tolerance should be no more than 0,5 mm for pins up to 57 mm and 1,0 mm for pins of larger diameter.

The trunnion pin should be a snug fit within the chamber and be long enough to prevent horizontal movement. The gap should be no more than 1% of the chamber length.

The lateral movement of the shank should not exceed 3°, see Fig 1.

**1.4.2 Welding**

Welded construction of fabricated anchors is to be done by qualified welders and in accordance with procedures approved by the Society in accordance with Chapter 12 and using approved welding consumables.

**1.4.3 Heat treatment**

Fabricated anchors may require to be stress relieved after welding depending upon weld thickness. Stress relief is to be carried out as indicated in the approved welding procedure. Stress relief temperature is not to exceed the tempering temperature of the base material.

**Figure 1 : Allowable lateral movement of shank**

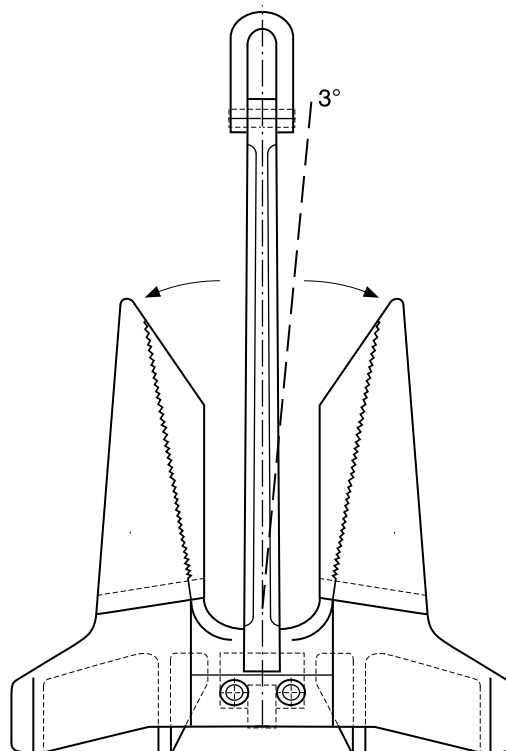

**1.4.4 Quality of anchors**

All parts must have a clean surface consistent with the method of manufacture and be free from cracks, notches, inclusions and other defects which would be prejudicial to their proper application in service.

**1.4.5 Repairs**

Any necessary repairs to forged and cast anchors are to be agreed by the Surveyor and carried out in accordance with the repair criteria respectively indicated in Chapter 5 and Chapter 6. Repairs to fabricated anchors are to be agreed by the Surveyor and carried out in accordance with the qualified weld procedures, by qualified welders.

**1.4.6 Anchor assembly**

Assembly and fitting are to be done in accordance with the design details.

Securing of the anchor pin, shackle pin or swivel by welding is to be done in accordance with an approved procedure.

**1.5 Tests and examination**

**1.5.1 General**

All types of anchors are not to be painted until all tests and inspections have been completed.

Reference is made to the general provisions given in Ch 1, Sec 1, [3.6] for visual, dimensional and non destructive examination.

**1.5.2 Proof load test**

Each forged or cast steel anchor, complete in all its parts, is to be subjected, in the presence of the Surveyor, to a proof load test at the load indicated in Tab 2 depending on the mass.

This requirement may be waived for anchors having a mass of 15000 kg and over, subject to special conditions agreed with the Society in each case.

The following mass is to be used in determining the test load:

- for stocked anchors, the mass of the anchor without the stock
- for stockless anchors, the total mass of the anchor
- for high holding power anchors, a mass equal to 1,33 times the total mass of the anchor
- for very high holding power anchors, a mass equal to twice the total mass of the anchor.

Testing machines are to be in accordance with requirements indicated in Chapter 2.

The load is to be applied between the shackle at one end and, at the other end, the arm/arms at a point located approximately one third of the length from its/their end. The test is to be performed in duplicate, in accordance with the following procedure:

- for anchors having four fixed arms, the load is to be applied first to one pair of arms and then to the opposite pair, applying it simultaneously to the pair concerned
- for stocked anchors with two fixed arms, the load in both tests is to be applied separately to both arms
- for stockless anchors with hinged arms, the load is to be applied in both opposite anchoring positions, and in each test it is to be applied simultaneously to the points of the arms mentioned above.

As far as the point of application of the load on the arms is concerned, the length of the arm is defined as:

- the length between the tip of each arm and the crown of the anchor, or
- the distance between the tips of the arms and the axis of rotation, in the case of stockless anchors with hinged arms.

For further details on the proof test, see Fig 2.

The difference between the gauge lengths *a*, defined in Fig 2, measured where 10% of the proof load was applied first and measured where the load has been reduced to 10% of the proof load from the proof load is not to exceed 0,01 *a*.

**Figure 2 : Proof load test**

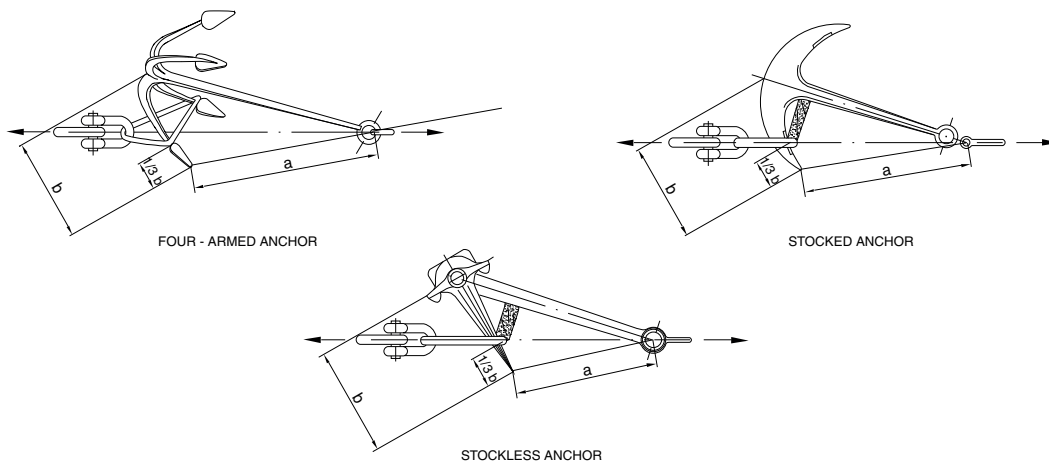

Table 2 : Proof load test

Mass (kg)	Proof load (kN)	Mass (kg)	Proof load (kN)	Mass (kg)	Proof load (kN)	Mass (kg)	Proof load (kN)	Mass (kg)	Proof load (kN)	Mass (kg)	Proof load (kN)
50	23,2	550	124	2200	376	4800	645	7800	861	17500	1390
55	25,2	600	132	2300	388	4900	653	8000	877	18000	1410
60	27,1	650	140	2400	401	5000	661	8200	892	18500	1440
65	28,9	700	149	2500	414	5100	669	8400	908	19000	1470
70	30,7	750	158	2600	427	5200	677	8600	922	19500	1490
75	32,4	800	166	2700	438	5300	685	8800	936	20000	1520
80	33,9	850	175	2800	450	5400	691	9000	949	21000	1570
90	36,3	900	182	2900	462	5500	699	9200	961	22000	1620
100	39,1	950	191	3000	474	5600	706	9400	975	23000	1670
120	44,3	1000	199	3100	484	5700	713	9600	987	24000	1720
140	49,0	1050	208	3200	495	5800	721	9800	998	25000	1770
160	53,3	1100	216	3300	506	5900	728	10000	1010	26000	1800
180	57,4	1150	224	3400	517	6000	735	10500	1040	27000	1850
200	61,3	1200	231	3500	528	6100	740	11000	1070	28000	1900
225	65,8	1250	239	3600	537	6200	747	11500	1090	29000	1940
250	70,4	1300	247	3700	547	6300	754	12000	1110	30000	1990
275	74,9	1350	255	3800	557	6400	760	12500	1130	31000	2030
300	79,5	1400	262	3900	567	6500	767	13000	1160	32000	2070
325	84,1	1450	270	4000	577	6600	773	13500	1180	34000	2160
350	88,8	1500	278	4100	586	6700	779	14000	1210	36000	2250
375	93,4	1600	292	4200	595	6800	786	14500	1230	38000	2330
400	97,9	1700	307	4300	604	6900	794	15000	1260	40000	2410
425	103	1800	321	4400	613	7000	804	15500	1270	42000	2490
450	107	1900	335	4500	622	7200	818	16000	1300	44000	2570
475	112	2000	349	4600	631	7400	832	16500	1330	46000	2650
500	116	2100	362	4700	638	7600	845	17000	1360	48000	2730

**Note 1:** Masses shown refer either to stockless anchors or to stocked anchors excluding stocks. The proof load for intermediate masses may be determined by linear interpolation.

**Note 2:** For high holding power (HHP) anchors, the required proof load is derived from the Table, using a mass equal to 1,33 times the actual mass of the HHP anchor.

**Note 3:** For very high holding power (VHHP) anchors, the required proof load is derived from the Table, using a mass equal to twice the actual mass of the VHHP anchor.

**1.5.3 Test programme for cast components**

Cast components can be subjected to the following programmes at the discretion of the Society:

- drop test as per [1.5.6], hammering test as per [1.5.7], visual examination as per [1.5.8] and general non-destructive examination as per [1.5.9]
- Charpy V-notch impact test on material to demonstrate at least 27 J average at 0°C, visual examination as per [1.5.8] and extended non-destructive examination as per [1.5.10].

**1.5.4 Test programme for forged components**

Forged components are to be subjected to visual examination as per [1.5.8] and weld repairs are to be examined as indicated in [1.5.10].

**1.5.5 Test programme for fabricated/welded components**

Fabricated/welded components are to be subjected to visual examination as per [1.5.8] and extended non-destructive examination as per [1.5.10].



**Table 3 : General NDE for ordinary, HHP and VHHP anchors**

Location	Method for ordinary and HHP anchors	Method for VHHP anchors
Feeders of castings	PT or MT	PT or MT and UT
Risers of castings	PT or MT	PT or MT and UT
All surfaces of castings	not required	PT or MT
Weld repairs	PT or MT	PT or MT
Forged components	not required	not required
Fabrication welds	PT or MT	PT or MT

**Table 4 : Extended NDE for ordinary, HHP and VHHP anchors**

Location	Method of NDE
Feeders of castings	PT or MT and UT
Risers of castings	PT or MT and UT
All surfaces of castings	PT or MT
Random areas of castings	UT
Weld repairs	PT or MT
Forged components	not required
Fabrication welds	PT or MT

**1.5.6 Drop test**

Each anchor fluke and shank is individually raised to a height of 4 m and dropped on to a steel slab without fracturing. The steel slab is to be suitable to resist the impact of the dropped component.

**1.5.7 Hammering test**

After the drop test, hammering tests are carried out on each anchor fluke and shank, which is slung clear of the ground, using a non-metallic sling, and hammered to check the soundness of the component. A hammer of at least 3 kg mass is to be used.

**1.5.8 Visual examination**

After proof loading visual inspection of all accessible surfaces is to be carried out.

**1.5.9 General non-destructive examination**

When required general non-destructive examination is to be carried out after proof load test as indicated in Tab 3 depending on the type of anchor.

**1.5.10 Extended non-destructive examination**

When required extended non-destructive examination is to be carried out after proof load test as indicated in Tab 4.

**1.5.11 Repairs**

If defects are detected by non-destructive examinations, repairs are to be carried out in accordance with [1.4.5].

For fracture and unsoundness detected in a drop test or hammering test, repairs are not permitted and the component is to be rejected.

**1.5.12 Mass and dimensional inspection**

The verification of mass and dimensions is the responsibility of the manufacturer. The surveyor may require to be present during these checks.

The mass of the anchor is to exclude the mass of the swivel, unless this is an integral component.

**1.5.13 Retests**

Tensile and/or Charpy V-notch impact retests are permitted in accordance with the requirements of Ch 2, Sec 2, [1.3] and Ch 2, Sec 4, [1.4].

**1.6 Identification, marking and certification**

**1.6.1 Identification**

The Manufacturer is to adopt a system of identification which will enable all finished anchors to be traced to the original materials and their manufacturing.

### 1.6.2 Marking

Anchors which meet the requirements are to be stamped on the shank and the fluke. The markings on the shank should be approximately level with the fluke tips. On the fluke, these markings should be approximately at a distance of two thirds from the tip of the bill to the center line of the crown on the right hand fluke looking from the crown towards the shank. The markings are to include:

- mass of anchor
- identification, e.g. test number or certificate number
- Society's stamp
- Manufacturer's mark.

Additionally the unique cast identification is to be cast on the shank and the fluke.

### 1.6.3 Certification

The testing documentation indicated in Ch 1, Sec 1, [4.2.1] is required and is to include all the information, as appropriate.

Anchors which meet the requirements are to be certified by the Society.

# Section 2 Stud Link Chain Cables and Accessories for Ships

## 1 Requirements

### 1.1 Scope

**1.1.1** The requirements of this Section apply to the materials, design, manufacture and testing of stud link anchor chain cables and accessories used for ships.

Reference is made to the general provisions given in Ch 1, Sec 1, [3.6] for visual, dimensional and non destructive examination.

### 1.2 Chain cable grades

**1.2.1** Stud link anchor chain cable grades are detailed as follows according to the steel grade used and the method of manufacture:

- a) grade Q1a, flash butt welded links made in Q1 steel grade
- b) grade Q2a, flash butt welded or drop forged links made in Q2 steel grade
- c) grade Q2b, cast links made in Q2 steel grade
- d) grade Q3a, flash butt welded or drop forged links made in Q3 steel grade
- e) grade Q3b, cast links made in Q3 steel grade.

### 1.3 Approval of chain cable manufacturers

**1.3.1** The manufacturing process of stud link anchor chain cables and accessories is to be approved by the Society. Provisions for the approval are given in NR480 "Approval of the Manufacturing Process of Metallic Materials".

Where materials with chemical composition or properties other than those given in [1.4] are proposed, their acceptance is at the Society's discretion. The same applies in the case of design of links different from [1.8.2].

### 1.4 Rolled steel bars

#### 1.4.1 Manufacturing process and approval

Approval of manufacturing process is required for grades Q2 and Q3. Provisions for the approval are given in NR480 "Approval of the Manufacturing Process of Metallic Materials".

Steel grade Q1 steel is to be cast in killed condition and steel grades Q2 and Q3 are to be killed and fine grain treated.

Steelmaker or chain cable manufacturer is to submit specifications of the steels used for grade Q3. These specifications are to contain all necessary details, such as manufacturing procedure, deoxydation practice, specified chemical composition, heat treatment and mechanical properties.

#### 1.4.2 Supply condition

Unless otherwise stipulated (i.e. heat treatment), the rolled bars are supplied in the as-rolled condition.

#### 1.4.3 Chemical composition

The chemical composition on ladle samples is to comply with the limits given in Tab 1 and the approved specification where applicable.

**Table 1 : Chemical composition on ladle for rolled steel bars**

Grade	Chemical composition					
	C (%) max.	Si (%)	Mn (%)	P (%) max.	S (%) max.	Al tot (%) min. (1)
Q1	0,20	0,15 - 0,35	min. 0,40	0,040	0,040	–
Q2 (2)	0,24	0,15 - 0,55	max. 1,60	0,035	0,035	0,020
Q3	According to the approved specification					
(1) Al may be replaced partly by other fine graining elements.						
(2) Subject to the agreement of the Society, additional alloying elements may be added.						



**Table 2 : Mechanical properties of chain cable materials**

Grade	R <sub>eH</sub> (N/mm <sup>2</sup> ) min	R <sub>m</sub> (N/mm <sup>2</sup> )	A <sub>5</sub> (%) min	Z (%) min	Notched bar impact test	
					Test temp. (°C)	KV (J) av. (1) min
Q1	–	370 - 490	25	–	–	–
Q2	295	490 - 690	22	–	0	27 (2)
Q3	410	min 690	17	40	0 (–20)	60 (35) (3)

(1) Energy average value of 3 tests. One individual value may be lower than the average value, but not below 70% of the average value stipulated.  
 (2) The impact test of grade 2 materials may be waived if the chain cable is supplied in a heat treated condition.  
 (3) In general, Charpy V impact tests are to be performed at the temperature of 0°C. At the discretion of the Society, the impact test of grade 3 materials may alternatively be carried out at –20°C; in such case the energy required, as shown in the Table, is 35 J.

**1.4.4 Mechanical tests**

For performance of mechanical tests, the steel bars are to be sorted according to heats and diameters into batches not exceeding 50 t each. From each batch a test sample is to be taken and subjected in full diameter to the heat treatment provided for the finished chain cable; see Tab 2. Details of the heat treatment must be indicated by the chain cable manufacturer.

From each test sample, one tensile and when required one set of three Charpy V notch impact test specimens with the notch axis radial to the bar are to be taken in the longitudinal direction at a distance of 1/6 diameter from the surface or as close as possible to this position (see Fig 1).

Mechanical tests are to be carried out by the steel mill or the chain cable manufacturer or a laboratory recognized by the Society, as agreed with the chain cable manufacturer and witnessed by a Society Surveyor.

When required, Charpy V notch impact test specimens are to be tested at the temperature prescribed in Tab 2 for the steel grade tested.

The mechanical test results are to comply with the requirements of Tab 2 for the steel grade tested.

**Figure 1 : Sampling of chain cable steel**

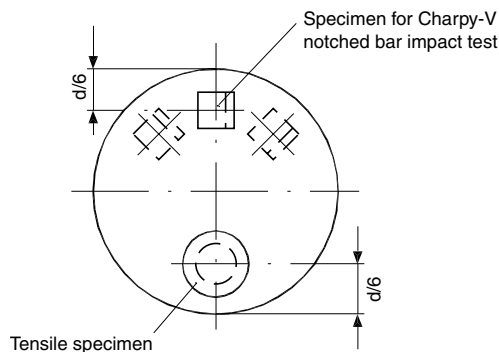

**1.4.5 Re-tests**

Re-tests requirements for tensile tests are to be in accordance with Ch 2, Sec 2, [1.3]. Failure to meet the specified requirements of either of both additional tests results in rejection of the batch represented.

Re-tests requirements for Charpy V-notch impact tests are to be in accordance with Ch 2, Sec 4, [1.4]. Failure to meet the requirements results in rejection of the batch represented.

If failure to pass the test is definitely attributable to improper heat treatment of the test sample, a new test sample may be taken from the same piece and re-heat treated. The complete test (both tensile and impact tests) is to be repeated; the original results obtained may be disregarded.

**1.4.6 Freedom from defects**

All products are to be checked by Manufacturers in relation to their surface conditions.

The rolled bars are to be free from internal and surface defects which might impair proper workability and use. Surface defects may be repaired by grinding, provided the permissible tolerance is not exceeded.

**1.4.7 Dimensional check - tolerances**

The diameter and roundness are to be within the tolerances specified in Tab 3, unless otherwise agreed.

**1.4.8 Identification of material**

Manufacturers are to establish an identification system ensuring traceability of the material to the original cast.

**Table 3 : Dimensional tolerances of rolled bars**

Nominal diameter (mm)	Tolerance on diameter (mm)	Tolerance on roundness $d_{max} - d_{min}$ (mm)
less than 25	-0 +1,0	0,60
25 - 35	-0 +1,2	0,80
36 - 50	-0 +1,6	1,10
51 - 80	-0 +2,0	1,50
81 - 100	-0 +2,6	1,95
101 - 120	-0 +3,0	2,25
121 - 160	-0 +4,0	3,00

**1.4.9 Marking**

The minimum markings required are the steelmaker’s brand mark, the steel grade and an abbreviated symbol of the heat. Steel bars having diameters up to and including 40 mm, combined into bundles, may be marked on permanently affixed labels.

**1.4.10 Material certification**

Bar material grade Q2 and Q3 is to be certified by the Society. For each consignment, the steelmaker is to provide the Surveyor with a certificate containing at least the following data:

- steel maker’s name and/or purchaser’s order number
- number and dimensions of bars and weight of consignment
- steel grade
- heat number
- manufacturing procedure
- chemical composition
- details of heat treatment of the test sample
- results of mechanical tests (where applicable)
- nos. of test specimens (where applicable).

**1.5 Forged steels**

**1.5.1 General requirements**

Forged steels used for the manufacture of chain cables and accessories are to be in compliance with Chapter 5, unless otherwise specified in the following requirements.

**1.5.2 Chemical composition**

The chemical composition of ladle samples is to comply with the approved specification. The steel maker is to determine and certify the chemical composition of each heat.

**1.5.3 Supply condition**

The raw material may be supplied in the as-rolled condition. Finished forgings are to be properly heat treated, i.e. normalised, normalised and tempered or quenched and tempered, whichever is specified for the relevant steel grade in Tab 4.

**1.6 Cast steels**

**1.6.1 General requirements**

Cast steels used for the manufacture of chain cables and accessories are to be in compliance with Chapter 6, unless otherwise specified in the following requirements.

**1.6.2 Chemical composition**

The chemical composition of ladle samples is to comply with the approved specification. The foundry is to determine and certify the chemical composition of each heat.

**Table 4 : Heat treatment of chain cables**

Grade	Condition of supply
Q1 (Q2) (1)	As-welded or normalised condition
Q2 Q3	Normalised, normalised and tempered or quenched and tempered condition
(1) Grade Q2 chain cables are generally to be normalised. The Society may, however, waive this requirement on the basis of an approval test, in which case additional requirements may be specified.	

**1.6.3 Heat treatment**

All castings are to be properly heat treated, i.e. normalised, normalised and tempered or quenched and tempered, whichever is specified for the relevant cast steel grade in Tab 4.

**1.7 Materials for studs**

**1.7.1** The studs are to be made of rolled, cast or forged steel corresponding to that of the chain cable or from ordinary steel grade with a carbon content generally not exceeding 0,25%. The use of other materials, e.g. grey or nodular cast iron is not permitted. Generally mechanical tests are not required.

**1.8 Design and manufacture of chain cables and accessories**

**1.8.1 Design**

The form and proportion of links and accessories are to be in accordance with recognized standards accepted by the Society, e.g. ISO 1704:2008 standard, or approved specification. Typical designs are given in Fig 2 and Fig 3. Where designs do not comply with these figures and where accessories are of welded construction, drawings and specifications giving full details of the manufacturing process and the heat treatment are to be submitted to the Society for approval.

A length of chain cable is to comprise an odd number of links.

**1.8.2 Manufacturing process**

Stud link chain cables are preferably to be manufactured by hot bending and flash butt-welding of rolled bars from steel grades Q1, Q2 or Q3. Manufacture of links by drop forging or steel casting is permitted.

The stud may be either forced, or forced and secured by welding, or solid with the link.

**Figure 2 : Typical design of chain links**

All dimensions are shown as multiples of the nominal diameter  $d$  of the common link.

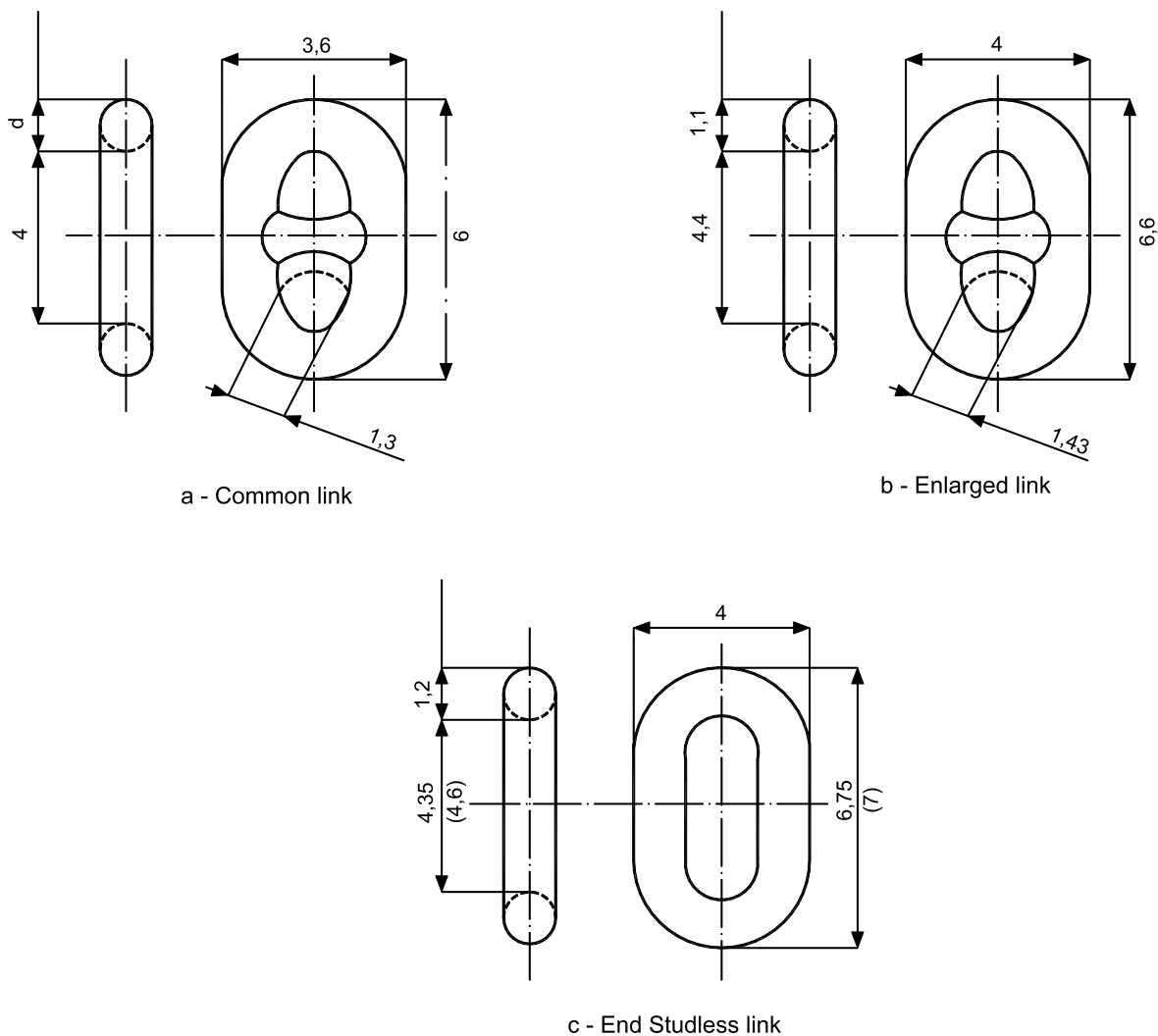

The dimensions in brackets may be chosen for end studless links in outboard end swivel pieces. The diameter of enlarged links and end studless links may be chosen in the range of chain cable diameters shown in Tab 7.

**Figure 3 : Typical design of shackles and swivels**

All dimensions are shown as multiples of the nominal diameter  $d$  of the common link.

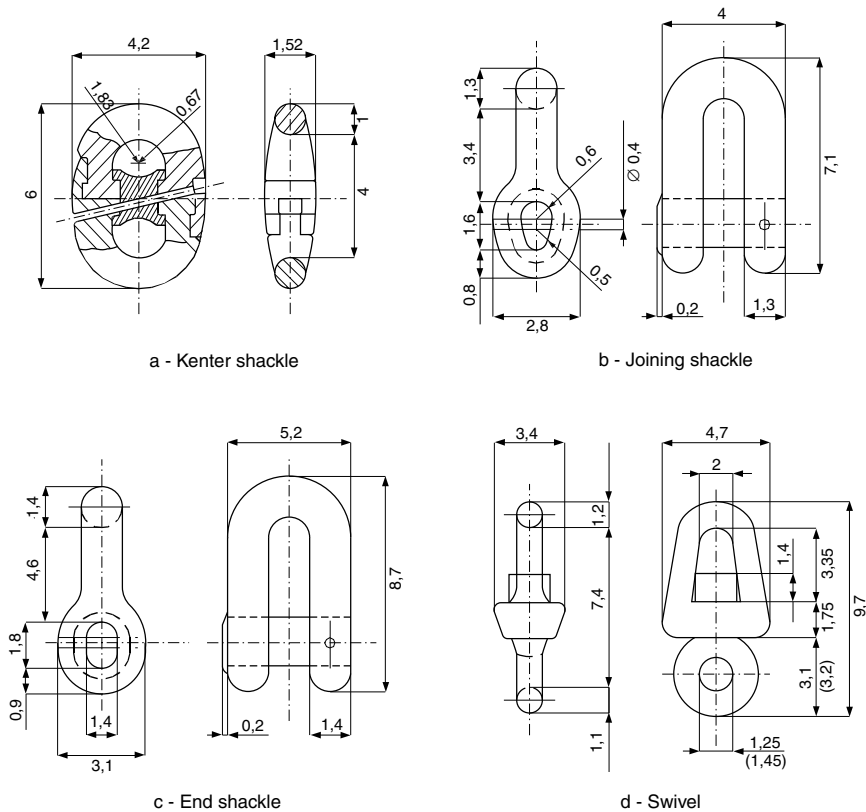

For swivels, dimensions in brackets may apply to cast steel swivels.

**1.8.3 Heat treatment and supply condition**

According to the steel grade, chain cables are to be supplied in one of the conditions specified in Tab 4. The heat treatment is to be performed before the proof and breaking load tests.

**1.8.4 Mechanical properties**

The mechanical properties of finished chain cables and accessories are to be in accordance with Tab 2 depending on the relevant chain cable grade.

**1.8.5 Proof and breaking load properties**

Chain cables and accessories are to be manufactured in a manner such to withstand the proof and breaking loads indicated in Tab 7, depending on the diameter and the relevant chain cable grade.

**1.8.6 Freedom from defects**

All individual parts are to have a clean surface consistent with the method of manufacture and be free from cracks, notches, inclusions and other defects that might impair proper workability, use and strength. The burrs produced by upsetting or drop forging are to be properly removed.

Minor surface defects may be ground off so as to leave a gentle transition to the surrounding surface provided the acceptable tolerances are not exceeded.

**1.8.7 Dimensions and tolerances**

The dimensions of links and accessories are to conform to the relevant recognised standard (see Fig 2 and Fig 3) or the approved specification.

The manufacturing tolerances on stud link chain are as follows:

- a) The cross-sectional area at the crown of the link is to have no negative tolerance. The plus tolerance on the diameter at the crown measured out of the plane of the link is not to exceed 5%. The negative tolerance on the diameter at the crown measured in the plane of the link is not to exceed:
  - – 1 mm when nominal diameter is  $\leq 40$  mm
  - – 2 mm when nominal diameter is  $> 40$  mm and  $\leq 84$  mm
  - – 3 mm when nominal diameter is  $> 84$  mm and  $\leq 122$  mm
  - – 4 mm when nominal diameter is  $> 122$  mm.

- b) The diameter measured at locations other than the crown is to have no negative tolerance. The plus tolerance is to be in accordance with Tab 3 except at the butt weld where it is to be in accordance with the agreed manufacturer’s specification.
- c) The maximum allowable tolerance on a length of five links, measured after proof load test with the chain loaded to about 10% of the proof load, is + 2,5%. No negative tolerance is permitted.
- d) All other dimensions are subject to a manufacturing tolerance of ± 2,5%, provided always that all components of the chain cable fit together properly.
- e) Studs are to be located in the links centrally and at right angles to the sides of the link, although the studs of the final link at each end of any length may also be located off-centre to facilitate the insertion of the joining shackle.

The following tolerances are regarded as being inherent in the method of manufacture and are acceptable provided that the stud fits snugly and its ends lie flush against the inside of the link.

Maximum off-centre distance “X”: 10% of the nominal diameter d,

Maximum deviation “α” from the 90°- position: 4°.

The tolerances are to be measured in accordance with Fig 4.

The manufacturing tolerances on accessories are as follows:

- nominal diameter: + 5%, no negative tolerance
- other dimensions: + or – 2,5%.

**Figure 4 : Manufacturing tolerances**

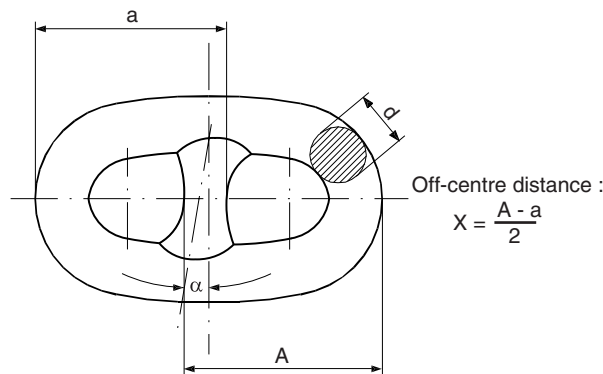

**1.8.8 Welding of studs**

Where studs are welded into the links of flash butt-welded chain cable, welding is to be carried out in compliance with the following conditions:

- a) all welds are to be carried out before the final heat treatment of the chain cable
- b) the stud ends are to fit the inside of the link without appreciable gap and the weld is restricted to one end only, i.e., opposite to the flash butt-weld. In general, the full periphery of the stud end is to be welded
- c) welding is to be made preferably in horizontal position by qualified welders, following an approved procedure and using suitable welding consumables
- d) the welds are to be free from defects liable to impair the proper use of the chain. Undercuts, end craters and similar defects are, where necessary, to be ground off.

**1.9 Testing of finished chain cables**

**1.9.1 Proof load test**

Each chain cable length (27,5 m maximum) is to be subjected to a loading test at the proof load appropriate to the particular chain cable as shown in Tab 7 and using a testing machine approved for the purpose. The chain cable is to be free from paint and anti-corrosive media.

Should a proof load test fail, the defective link(s) is (are) to be replaced. If the entire chain cable length is not re-heat treated, each new link is to be subjected to a satisfactory method of heat treatment (normalising, normalising and tempering, quenching and tempering) as required, without affecting adjacent links. In such case, extra link is to be manufactured and tested in the same way as the new link and subjected to mechanical tests as required by [1.9.3]. The repaired length is then to be subjected to a repeat of the proof load test. In addition, the manufacturer shall make appropriate investigations to identify the cause of the failure.

**1.9.2 Breaking load test**

On every four chain cable lengths, a breaking test specimen, comprising at least three links, is to be taken and tested at the breaking load appropriate to the particular chain cable as shown in Tab 7. The breaking load is to be maintained for a minimum of 30 seconds. The links of the breaking test specimen are to be made at the same time and in the same way as the chain cable

and heat treated together with it. Only after this, the breaking test specimen may be separated from the chain cable in the presence of the surveyor. The breaking test specimen is to be free from paint and anti-corrosive media.

Should a breaking load test fail, a further test specimen may be taken from the same length of chain cable and tested. The test will be considered successful if the requirements are then satisfied.

If the retest fails, the length of chain cable concerned is rejected. If the manufacturer so wishes, the remaining three lengths belonging to the batch may then be individually subjected to testing at the breaking load. If one of such tests fails to meet the requirements, the entire batch is rejected.

In addition, the manufacturer shall make appropriate investigations to identify the cause of the failure.

If the tensile loading capacity of the testing machine is insufficient to apply the breaking load for chain cables of large diameter, the Society may agree an alternative testing procedure upon special consideration.

**1.9.3 Mechanical tests on chain cables grade Q2 and Q3**

The scope of the mechanical tests on finished chain cables is given in Tab 5.

For grade Q3 and where required for grade Q2 chain cables, one tensile and one set of Charpy V-notch impact test specimens are to be taken in a link at the side opposite the weld from every four lengths of chain cable.

For grade Q3 chain cable and where required for grade Q2, an additional tensile test specimen across the weld and an additional set of Charpy V-notch impact test specimens having the notch located in the fusion line of the weld are to be taken in a link from every four lengths of chain cable.

The location of tensile and Charpy V-notch test specimens is to be as per [1.4.4] and Fig 1.

At the discretion of the Society, additional tests as mentioned above may be required for non-heat treated grade Q2 chain cables, as stated at the approval.

The extra link(s) for taking the mechanical test specimens (or where the links are small, several links) is (are) to be made as part of the chain cable and is (are) to be heat treated with it. This (these) link(s) is (are) not to be part of the same length as that from which the breaking test specimen is taken, unless each length is subjected to breaking load test.

The tensile and Charpy V impact test results are to comply with the requirements set in Tab 6.

**Table 5 : Scope of the mechanical tests for finished chain cables and accessories**

Grade	Manufacturing method	Condition of supply (1)	Number of tests on every four lengths			
			Breaking load test (2)	Tensile test base material	Charpy V-notch impact test Base material	Weldment
Q1a	flash-butt welding	AW	1	not required	not required	not required
Q2a	flash-butt welding	AW	1	1	3	3
		N	1	not required	not required	not required
Q3a	flash-butt welding	N, N+T, Q+T	1	1 (4)	3	3
Q2a, Q2b	forged or cast	N	1	1	3 (3)	not applicable
Q3a, Q3b	forged or cast	N, N+T, Q+T	1	1	3	not applicable

(1) AW= as welded; N = normalising; N+T= normalising and tempering; Q + T = quenching and tempering.  
 (2) For test sampling, see [1.9.2].  
 (3) For chain cables, Charpy V-notch impact test is not required.  
 (4) Additional tensile test across the weld.

**Table 6 : Mechanical properties for finished chain cables and accessories**

Grade	Base material	Welded area		
		Tensile test (1) Elongation A <sub>5</sub> (%) min.	Charpy V-notch impact test	
			Test temperature (°C)	Impact energy (J) min. (2)
Q 1	The requirements of Tab 2 are applicable	25	not required	not required
Q2a, Q2b		18	0	27
Q3a, Q3b		14	0	50
Q3a, Q3b			-20	(27) (3)

(1) For the tensile and yield strengths, the requirements of Tab 2 are applicable; for grade Q3 a reduction of area is not specified.  
 (2) Average value from 3 test specimens. One individual value may be lower than the average value, but not below 70% of the average value stipulated.  
 (3) In general, Charpy V impact tests are to be performed at the temperature of 0°C. However, at the discretion of the Society, the impact test of grade Q3 materials may alternatively be carried out at -20°C; in such case, as shown in the Table, the energy required is 27 J.

**1.9.4 Marking**

Chain cables which meet the requirements are to be stamped at both ends of each length at least with the following marks, as indicated in Fig 5:

- chain cable grade
- certificate number
- Society's stamp.

**Figure 5 : Marking of chain cables**

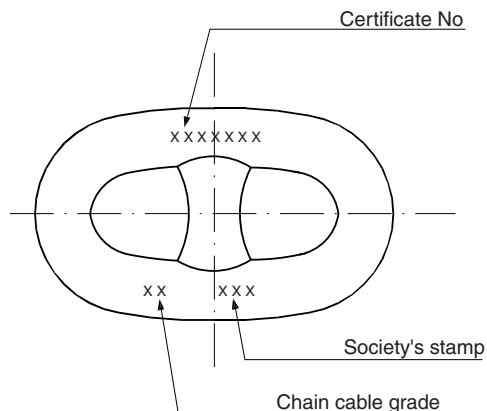

**1.9.5 Certification**

The testing documentation indicated in Ch 1, Sec 1, [4.2.1] is required and is to include all the information, as appropriate. Chain cables which meet the requirements are to be certified by the Society.

**1.10 Testing of accessories**

**1.10.1 Proof load test**

All accessories are to be subjected to the proof load test at the proof load specified for the corresponding chain in Tab 7, and in accordance with the provisions of [1.9.1].

**1.10.2 Breaking load test**

From each manufacturing batch (same grade, size and heat treatment batch, but not necessarily representative of each heat of steel or individual purchase order) of 25 units or less of detachable links, shackles, swivels, swivel shackles, enlarged links and end links, and from each manufacturing batch of 50 units or less of kenter shackles, one unit is to be subjected to the breaking load test specified for the corresponding chain given by Tab 7 and in accordance with the provisions of [1.9.2], as appropriate. Parts tested in this way may not be put to further use. Enlarged links and end links need not be tested provided that they are manufactured and heat treated together with the chain cable.

The Society may waive the breaking load test if:

- a) the breaking load has been demonstrated during the approval testing of parts of the same design,
- b) the mechanical properties, inclusive of impact energy, of each manufacturing batch are proved, and
- c) the parts are subjected to suitable non-destructive testing.

Notwithstanding the above, the accessories, which have been successfully tested at the prescribed breaking load appropriate to the chain, may be used in service, on a case by case basis, where the accessories are manufactured with the following:

- a) the material having higher strength characteristics than those specified for the part in question (e.g. grade Q3 materials for accessories for grade Q2 chain)
- b) or, alternatively, the same grade material as the chain but with increased dimensions subject to successful test proving that the breaking strength of such accessories is not less than 1,4 times the prescribed breaking load of the chain for which they are intended.

**1.10.3 Mechanical properties and tests**

Unless otherwise accepted by the Society, the forging or casting must at least comply with the mechanical properties given in Tab 6, when properly heat treated.

For test sampling, forgings and castings of similar dimensions originating from the same heat treatment charge and the same heat of steel are to be combined into one batch.

Mechanical tests are to be carried out in the presence of the Surveyor, depending on the type and grade of material used. From each batch, one tensile test specimen and three Charpy V-notch impact test specimens are to be taken in accordance with Tab 5 and tested in accordance with Chapter 2.

Enlarged links and end links need not be tested provided that they are manufactured and heat treated together with the chain cable.



**1.10.4 Marking**

Accessories which meet the requirements are to be stamped as follows:

- chain cable grade
- certificate number
- Society' stamp.

**1.10.5 Certification**

The testing documentation indicated in Ch 1, Sec 1, [4.2.1] is required and is to include all the information, as appropriate.

Accessories which meet the requirements are to be certified by the Society.

**Table 7 : Proof and breaking loads for stud link chain cables**

Chain diameter (mm)	Grade Q1		Grade Q2		Grade Q3		Minimum mass per length of 27,50m (1)	
	Proof load (kN)	Breaking load (kN)	Proof load (kN)	Breaking load (kN)	Proof load (kN)	Breaking load (kN)	with D shackle (kg)	with lugless shackle (kg)
11	35,8	51	51	71,7	71,7	102	–	–
12,5	46	65,7	65,7	92	92	132	100	98
14	57,9	82	82	116	116	165	122	120
16	75,5	107	107	150	150	216	157	155
17,5	89	127	127	179	179	256	186	184
19	105	150	150	211	211	301	218	215
20,5	123	175	175	244	244	349	253	250
22	140	200	200	280	280	401	290	287
24	167	237	237	332	332	476	343	339
26	194	278	278	389	389	556	400	395
28	225	321	321	449	449	642	462	456
30	257	368	368	514	514	735	530	523
32	291	417	417	583	583	833	603	594
34	328	468	468	655	655	937	680	670
36	366	523	523	732	732	1050	760	750
38	406	581	581	812	812	1160	850	835
40	448	640	640	896	896	1280	930	915
42	492	703	703	981	981	1400	1030	1010
44	538	769	769	1080	1080	1540	1140	1120
46	585	837	837	1170	1170	1680	1235	1210
48	635	908	908	1270	1270	1810	1345	1320
50	686	981	981	1370	1370	1960	1460	1430
52	739	1060	1060	1480	1480	2110	1585	1555
54	794	1140	1140	1590	1590	2270	1700	1665
56	851	1220	1220	1710	1710	2430	1840	1800
58	909	1290	1290	1810	1810	2600	1980	1930
60	969	1380	1380	1940	1940	2770	2120	2065
62	1030	1470	1470	2060	2060	2940	2255	2200
64	1100	1560	1560	2190	2190	3130	2395	2330
66	1160	1660	1660	2310	2310	3300	2570	2505
68	1230	1750	1750	2450	2450	3500	2715	2635
70	1290	1840	1840	2580	2580	3690	2900	2815
73	1390	1990	1990	2790	2790	3990	3150	3065
76	1500	2150	2150	3010	3010	4300	3425	3315
78	1580	2260	2260	3160	3160	4500	3620	3500
81	1690	2410	2410	3380	3380	4820	3880	3745

(1) These values are not mandatory and are given for information only.



Chain diameter (mm)	Grade Q1		Grade Q2		Grade Q3		Minimum mass per length of 27,50m <b>(1)</b>	
	Proof load (kN)	Breaking load (kN)	Proof load (kN)	Breaking load (kN)	Proof load (kN)	Breaking load (kN)	with D shackle (kg)	with lugless shackle (kg)
84	1800	2580	2580	3610	3610	5160	4135	3980
87	1920	2750	2750	3850	3850	5500	4485	4315
90	2050	2920	2920	4090	4090	5840	4840	4655
92	2130	3040	3040	4260	4260	6080	5040	4845
95	2260	3230	3230	4510	4510	6440	5410	5190
97	2340	3340	3340	4680	4680	6690	5610	5375
100	2470	3530	3530	4940	4940	7060	5980	5725
102	2560	3660	3660	5120	5120	7320	6170	5900
105	2700	3850	3850	5390	5390	7700	6540	6245
107	2790	3980	3980	5570	5570	7960	6910	6610
111	2970	4250	4250	5940	5940	8480	7270	6930
114	3110	4440	4440	6230	6230	8890	7885	7505
117	3260	4650	4650	6510	6510	9300	8260	7850
120	3400	4850	4850	6810	6810	9720	8630	8190
122	3500	5000	5000	7000	7000	9990	9065	8605
124	3600	5140	5140	7200	7200	10280	9200	8725
127	3750	5350	5350	7490	7490	10710	9870	9370
130	3900	5570	5570	7800	7800	11140	10250	9690
132	4000	5720	5720	8000	8000	11420	10730	10145
137	4260	6080	6080	8510	8510	12160	11575	10920
142	4520	6450	6450	9030	9030	12910	12420	11690
147	4790	6840	6840	9560	9560	13660	13265	12455
152	5050	7220	7220	10100	10100	14430	14090	13195
157	5320	7600	7600	10640	10640	15200	15030	14080
162	5590	7990	7990	11170	11170	15970	16000	14990

**(1)** These values are not mandatory and are given for information only.

## Section 3 Studless Chain Cables for Ships

### 1 Requirements

#### 1.1 Scope

**1.1.1** The requirements of this Section apply to the materials and testing of studless chain cables used for ships. Reference is made to the general provisions given in Ch 1, Sec 1, [3.6] for visual, dimensional and non destructive examination.

#### 1.2 Manufacturing

**1.2.1** The requirements of Sec 2, [1.3.1] are to be complied with.

#### 1.3 Studless chain cable grades

**1.3.1** Depending on the nominal tensile strength of the steel used for manufacture, studless chain cables are divided into the following grades:

SL1, SL2 and SL3 for steels in compliance with requirements for stud link steel grades Q1, Q2 and Q3, respectively.

#### 1.4 Short and long links

**1.4.1** The provisions of this Section apply to short studless link chain cables.

When long studless link chain cables are intended to be used, the steel properties are to be submitted by the Manufacturer. The tensile strength and yield stress minimum values are to be specially adapted for each grade, so that the chain cable can withstand the proof and breaking loads indicated in Tab 1 depending on the relevant chain cable grade.

As a rule, the use of long links is not permitted for SL3 studless chain cables.

#### 1.5 Materials for studless chain cables

##### 1.5.1 Requirements for materials

The general requirements concerning material Manufacturers, manufacturing procedure, supply condition, freedom from defects and dimensional tolerances are the same as those given in Sec 2, [1.3.1], Sec 2, [1.4.1], Sec 2, [1.4.2], Sec 2, [1.4.6] and Sec 2, [1.4.7] for stud link chain cables.

The chemical composition and mechanical properties of steels to be used for manufacturing chains of grades SL1, SL2 and SL3 are to comply with the prescriptions given in Sec 2, Tab 2 (mechanical properties) and Sec 2, Tab 1 (chemical composition) for grades Q1, Q2 and Q3, respectively.

For SL3 chain cables, the minimum tensile requirements may be reduced down to 365 N/mm<sup>2</sup> (instead of 410 N/mm<sup>2</sup>) for yield stress and 610 N/mm<sup>2</sup> (instead of 690 N/mm<sup>2</sup>) for tensile strength on condition that the finished chain can withstand the required proof and breaking loads.

##### 1.5.2 Testing of materials

The requirements for testing of material for studless chain cables of grades SL1, SL2 and SL3 are the same as for testing of the corresponding grades Q1, Q2 and Q3, given in Sec 2, [1.4.4].

However, for grades SL1 and SL2, material testing in the presence of the Surveyor is not required, and the supply of a works' certificate may be admitted on condition that all the bars can be identified with the corresponding certificate.

#### 1.6 Testing of finished chain cables

##### 1.6.1 General

Studless chain cables and corresponding accessories are to withstand the proof and breaking loads indicated in Tab 1, depending on the relevant studless chain cable grade.

Mechanical testing on links is required for grade SL3 only.

##### 1.6.2 Proof load test

All finished studless chain cables are to be subjected, over their full length, to a loading test at the proof load appropriate to the particular chain as shown in Tab 1. For the load test, an approved testing machine is to be used.

Tests are to be conducted as indicated in Sec 2, [1.9.1] for stud link chain cables.

**1.6.3 Breaking load tests**

Sample lengths, comprised of at least three links and taken every four 27,5 m lengths or every 110 m from the chain cables, are to be tested at the breaking loads shown in Tab 1.

The conditions for execution and separation of the three link samples are the same as those prescribed in Sec 2, [1.9.2].

Tests are to be conducted as indicated in Sec 2, [1.9.2] for stud link chain cables.

**1.6.4 Mechanical tests on grade SL3 studless chain cables**

For grade SL3, tensile tests and Charpy V-notch tests are to be performed as required for Q3 stud link chain cables (see Sec 2, [1.9.3]).

The values to be obtained are:

- tensile properties: the same values as required for the round bars used to manufacture the chain cables
- Charpy V-notch impact tests: the same as prescribed in Sec 2, Tab 6 for Q3 stud link chain cables.

No mechanical tests are required on links with a nominal diameter under 20 mm.

**1.6.5 Dimensions and tolerances**

The dimensions of links are to comply with a recognised standard. Typical design of a studless link is given in Fig 1.

The tolerances are the same as those prescribed in Sec 2, [1.8.7] for stud link chain cables.

**1.6.6 Galvanising in manufacture**

When galvanising is required (mainly for pleasure craft), this is to be made by the hot process, following the standard ISO 1461.

The average mass of the coating (for chains above 5 mm in diameter) is not to be under 500 g/m<sup>2</sup>. The tolerances given in [1.6.5] are to be maintained after the galvanising operations.

The required proof and breaking load tests are to be carried out after the galvanising is completed.

**1.6.7 Marking**

Studless chain cables which meet the requirements are to be stamped at both ends of each length as indicated in Sec 2, [1.9.4] for stud link chain cables.

**Table 1 : Proof and breaking loads for studless chain cables**

Chain cable diameter (mm)	Grade SL1		Grade SL2		Grade SL3		Mass of 100 m of chain	
	Proof load (kN)	Breaking load (kN)	Proof load (kN)	Breaking load (kN)	Proof load (kN)	Breaking load (kN)	Normal link (kg)	Short link (kg)
6,0	6,5	13	9	18	13	26	79	86
8,0	12,0	24	17	34	24	48	141	153
10,0	18,5	37	26	52	37	74	240	240
11,0	22,5	45	32	64	45	90	265	289
12,5	29,0	58	41	82	58	116	345	375
14,5	39,0	78	55	110	78	156	462	503
16,0	47,5	95	67	134	95	190	563	612
17,5	56,5	113	80	160	113	226	675	732
19,0	67,0	134	95	190	134	268	794	865
20,5	78,0	156	111	222	156	312	928	1005
22,0	90,0	180	128	256	180	360	1063	1155
24,0	106	212	151	302	212	424	1268	1380
25,5	120	240	170	340	240	480	1432	1560
27,0	135	270	192	384	270	540	1610	1742
28,5	150	300	213	426	300	600	1788	1942
30,0	166	332	236	472	332	664	1984	2155
32,0	189	378	268	536	378	756	2255	2480
33,0	201	402	285	570	402	804	2396	2605
35,0	226	452	321	642	452	904	2705	2940
37,0	253	506	359	718	506	1012	3020	3380
38,0	267	534	379	758	534	1068	3200	3460
40,0	296	592	420	840	592	1184	3520	3830

Figure 1 : Studless link for studless chain cable

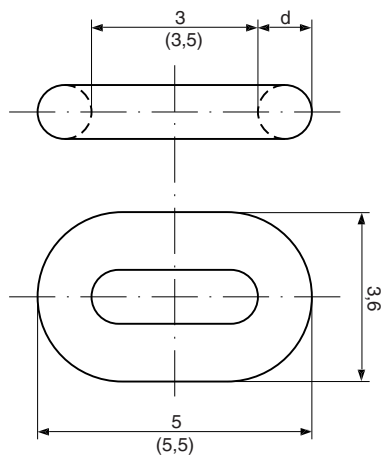

All dimensions are shown as multiples of the nominal diameter  $d$ .  
The dimensions in brackets correspond to long link chain cables.

# Section 4 Offshore Mooring Chain Cables and Accessories

## 1 General requirements

### 1.1 Scope

**1.1.1** These requirements apply to offshore units and single point moorings contracted for construction on or after 1st July 2017 and when the application for certification of mooring chains and accessories is dated on or after 1st July 2017.

**1.1.2** The requirements of this Section apply to the materials, design, manufacture and testing of offshore mooring chain and accessories intended to be used for application such as: mooring of mobile offshore units, mooring of floating production units, mooring of offshore loading systems and mooring of gravity based structures during fabrication.

Mooring equipment covered are common stud and studless links, connecting common links (splice links), enlarged links, end links, detachable connecting links (shackles), end shackles, subsea connectors, swivels and swivel shackles.

Studless link chain is normally deployed only once, being intended for long-term permanent mooring systems with pre-determined design life.

Each grade is to be individually approved. Approval for a higher grade does not constitute approval of a lower grade. If it is demonstrated to the satisfaction of the Society that the higher and lower grades are produced to the same manufacturing procedure using the same chemistry and heat treatment, consideration will be given to qualification of a lower grade by a higher. The parameters applied during qualification are not to be modified during production.

**1.1.3** Reference is made to the general provisions given in Ch 1, Sec 1, [3.6] for visual, dimensional and non destructive examination.

### 1.2 Chain grades

**1.2.1** Depending on the nominal tensile strength of the steels used for manufacture, chains are to be subdivided into five grades, i.e.: QR3, QR3S, QR4, QR4S and QR5.

Manufacturers propriety specifications for QR4S and QR5 may vary subject to design conditions and the acceptance of the Society.

Each grade is to be individually approved. Approval for a higher grade does not constitute approval of a lower grade.

### 1.3 Approval of chain manufacturers

**1.3.1** Offshore mooring chains are to be manufactured only by works approved by the Society. For this purpose approval tests are to be carried out, the scope of which is to include proof and breaking load tests, measurements and mechanical tests including fracture mechanics tests.

**1.3.2** Manufacturers are to submit for review and approval the sequence of operations from receiving inspection to shipment and details of the following manufacturing processes:

- a) bar heating and bending including method, temperatures, temperature control and recording
- b) flash welding including current, force, time and dimensional variables as well as control and recording of parameters, maintenance procedure and programme for welding machine
- c) flash removal including method and inspection
- d) stud insertion method, for stud link chain
- e) heat treatment including furnace types, means of specifying, controlling and recording of temperature and chain speed and allowable limits, quenching bath and agitation, cooling method after exit
- f) proof and break loading including method/machine, means of horizontal support (if applicable), method of measurement and recording
- g) non-destructive examination procedures
- h) the manufacturer's surface quality requirement of mooring components is to be submitted
- i) the manufacturer's procedure for removing and replacing defective links without heat treatment of the entire chain.

**1.3.3** For initial approval CTOD tests are to be carried out on the particular mooring grade of material. CTOD tests are to be done in accordance with a recognized standard such as BS 7448 Parts 1 & BS EN ISO 15653:2010.

The CTOD test piece is to be a standard 2 x 1 single edge notched bend piece, test location as shown in Fig 1. The notch of the CTOD specimen is to be located as close to the surface as practicable.

The minimum test piece size shall be 50 mm x 25 mm for chain diameters less than 120 mm, and 80 mm x 40 mm for diameters 120 mm and above. CTOD specimens are to be taken from both the side of the link containing the weld and from the opposite side. Three links are to be selected for testing, a total of 6 CTOD specimens. The tests are to be taken at -20°C and the lowest CTOD of each set of 3 specimens shall meet the minimum values indicated in Tab 1.

**Table 1 : Minimum CTOD test values for chain type**

Chain type	QR3, in mm		QR3S, in mm		QR4, in mm		QR4S and QR5, in mm	
	BM	WM	BM	WM	BM	WM	BM	WM
Stud link	0,20	0,10	0,22	0,11	0,24	0,12	0,26	0,13
Studless	0,20	0,14	0,22	0,15	0,24	0,16	0,26	0,17

**Figure 1 : Location of CTOD test specimens**

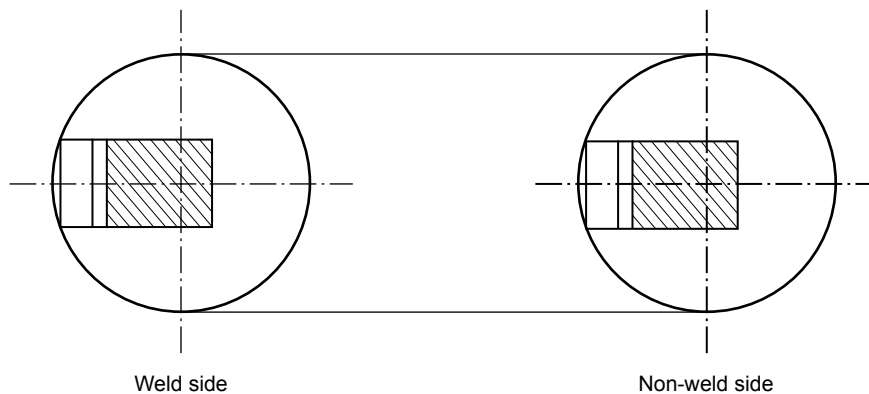

**1.3.4** Calibration of furnaces shall be verified by measurement and recording of a calibration test piece.

The manufacturer shall submit a procedure for calibration of furnaces and temperature uniformity surveys which shall include the following requirements:

- the temperature uniformity of furnaces is to be surveyed whenever approval of manufacturer is requested and at least annually during normal operating conditions
- a calibration test piece with dimensions equivalent to the maximum size of link manufactured, and, instrumented with two thermocouples is to be used. One thermocouple shall be attached to the surface of the straight part and one thermocouple shall be imbedded in a drilled hole located at the mid thickness position of the straight part of the calibration test piece
- furnaces are to be checked by conveying the calibration test piece through the furnaces at representative travel speed
- the time-temperature curves shall show that the temperatures throughout the cross section and the soaking times are within specified limits as given in the heat treatment procedure.

**1.3.5** For QR4S and QR5 chain and accessories, prior to approval, the manufacturer is to have undertaken experimental tests or have relevant supporting data to develop the chain and accessory material.

The tests and data may include: fatigue tests, hot ductility tests (no internal flaws are to develop whilst bending in the link forming temperature range), welding parameter research, heat treatment study, strain age resistance, temper embrittlement study, stress corrosion cracking (SCC) data and hydrogen embrittlement (HE) study, using low strain test pieces in hydrated environments. Reports indicated the results of experimental tests are to be submitted.

**1.4 Approval of quality system at chain and accessory manufacturers**

**1.4.1** Chain and accessory manufacturers are to have a documented and effective quality system approved by the Society. The provision of such a quality system is required in addition to, and not in lieu of, the witnessing of tests by a Surveyor as specified in this Section.

**1.5 Approval of steel mills - Rolled bar**

**1.5.1** Bar materials intended for chain and accessories are to be manufactured only by works approved by the Society. The approval is limited to a nominated supplier of bar material. If a chain manufacturer wishes to use material from a number of suppliers, separate approval tests must be carried out for each supplier.

**1.5.2** Approval will be given only after successful testing of the completed chain.

Each grade is to be individually approved. Approval for a higher grade does not constitute approval of a lower grade. If it is demonstrated to the satisfaction of the Society that the higher and lower grades are produced to the same manufacturing procedure using the same chemistry and heat treatment, consideration will be given to qualification of a lower grade by a higher. The parameters applied during qualification are not to be modified during production.

The approval will normally be limited up to the maximum diameter equal to that of the chain diameter tested. The rolling reduction ratio is to be recorded and is to be at least 5:1. The rolling reduction ratio used in production can be higher, but should not be lower than that qualified.

**1.5.3** The steelmaker is to submit a specification of the chemical composition of the bar material, which must be approved by the Society and by the chain manufacturer. The steelmaker is to confirm by analysis and testing that the specification is met. For grades QR4, QR4S and QR5 chain the steel shall contain a minimum of 0,20 percent of molybdenum.

**1.5.4** A heat treatment sensitivity study simulating chain production conditions shall be applied in order to verify mechanical properties and establish limits for temperature and time combinations. All test details and results are to be submitted to the Society.

**1.5.5** The bar manufacturer is to provide evidence that the manufacturing process produces material that is resistant to strain ageing, temper embrittlement and for QR3S, QR4, QR4S and QR5, hydrogen embrittlement. All test details and results are to be submitted to the Society.

## **1.6 Approval of forges and foundries - Accessories**

**1.6.1** Forges and foundries intending to supply finished or semi-finished accessories are to be approved by the Society. A description of manufacturing processes and process controls is to be submitted to the Society. The scope of approval is to be agreed with the Society.

The approval is to be limited to a nominated supplier of forged or cast material. If an accessory manufacturer wishes to use material from a number of suppliers, a separate approval must be carried out for each supplier.

**1.6.2** Approval will be given only after successful testing of the completed accessory.

Each grade is to be individually approved. Approval for a higher grade does not constitute approval of a lower grade. If it is demonstrated to the satisfaction of the Society that the higher and lower grades are produced to the same manufacturing procedure using the same chemistry and heat treatment, consideration will be given to qualification of a lower grade by a higher. The parameters applied during qualification are not to be modified during production.

The approval will normally be limited to the type of accessory and the designated mooring grade of material up to the maximum diameter or thickness equal to that of the completed accessory used for qualification unless otherwise agreed by the Society.

For different accessories that have the same geometry, the tests for initial approval are to be carried out on the one having the lowest reduction ratio.

Qualification of accessory pins to maximum diameters is also required.

Individual accessories of complex geometries will be subject to the Society requirements.

**1.6.3** Forgings are to have wrought microstructure and the minimum reduction ratio is to be 3 to 1. The forging reduction ratio, used in the qualification tests, from cast ingot/slab to forged component is to be recorded. The forging reduction ratio used in production can be higher, but should not be lower than that qualified.

The degree of upsetting during qualification is to be recorded and maintained during production. Heat cycling forging and reheating is to be monitored by the manufacturer and recorded in the forging documentation.

The manufacturer is to have a maintenance procedure and schedule for dies and tooling which shall be submitted to the Society.

**1.6.4** The forge or foundry is to submit a specification of the chemical composition of the forged or cast material, which must be approved by the Society. For grades QR4, QR4S and QR5 chain the steel should contain a minimum of 0,20 per cent of molybdenum.

**1.6.5** Forges and foundries are to provide evidence that the manufacturing process produces material that is resistant to strain ageing, temper embrittlement and for QR4S and QR5 grades, hydrogen embrittlement.

A heat treatment sensitivity study simulating accessory production conditions shall be applied in order to verify mechanical properties and establish limits for temperature and time combinations (cooling after tempering shall be appropriate to avoid temper embrittlement). All test details and results are to be submitted to the Society.

**1.6.6** For initial approval CTOD tests are to be carried out on the particular mooring grade of material. Three CTOD tests are to be done in accordance with a recognized standard such as BS 7448 Parts 1 & BS EN ISO 15653:2010. For rectangular accessories, the CTOD test piece is to be a standard 2 x 1 single edge notched bend specimen of thickness equal to full thickness of material to be tested. Sub-sized specimens can be used subject to approval of the Society.

For circular geometries the minimum cross section of the test piece shall be 50 x 25 mm for accessory diameters less than 120 mm, and 80 x 40 mm for diameters 120 mm and above.

The notch of the CTOD specimen is to be located as close to the surface as practicable.

The tests are to be taken at -20°C and the lowest CTOD of each set of 3 specimens shall meet the minimum values indicated in Tab 2.

Fig 2(a) shows the CTOD location for circular and rectangular cross sections such as those of the D-shackle and accessories fabricated from rectangular sections. The orientation of the specimen shall consider the direction of the grain flow. Fig 2(b) shows two possible positions for CTOD test specimens with notch orientation for rectangular type accessories.



Table 2 : Minimum CTOD test values for accessories

Grade of accessory	QR3, in mm	QR3S, in mm	QR4, in mm	QR4S and QR5, in mm
CTOD	0,20	0,22	0,24	0,26

Figure 2 : Location of CTOD test specimens: a) Circular type accessory and b) rectangular type accessory, B corresponds to the thickness of material, the grain flow is considered in the longitudinal direction X

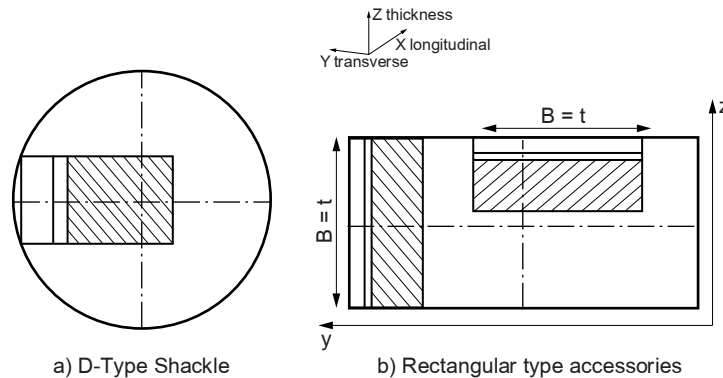

1.6.7 Calibration of furnaces shall be verified by measurement and recording of a calibration test piece with dimensions equivalent to the maximum size of accessory manufactured. Thermocouples are to be placed both on the surface and in a drilled hole located at the mid thickness position of the calibration block.

The furnace dimensions shall be such as to allow the whole furnace charge to be uniformly heated to the necessary temperature. Temperature uniformity surveys of heat treatment furnaces for forged and cast components shall be carried out according to API Spec 6A/ISO 10423 Annex M or ASTM A991.

The initial survey shall be carried out with maximum charge (load) in the furnace. Subsequent surveys shall be carried out annually and may be carried out with no furnace charge.

The quench bath maximum temperature and the maximum heat treatment transfer times from furnace to quench are to be established and documented. During production the established quenching parameters are to be followed and records of bath temperatures and transfer times are to be maintained.

1.6.8 For QR4S and QR5 refer to additional requirements in [1.3.5].

## 2 Materials

### 2.1 Scope

2.1.1 These requirements apply to rolled steels, forgings and castings used for the manufacture of offshore mooring chain and accessories.

### 2.2 Rolled steel bars

#### 2.2.1 Steel manufacture

- the steels are to be manufactured by basic oxygen, electric furnace or such other process as may be specially approved. All steels are to be killed and fine grain treated
- steel for bars intended for grade QR4S and QR5 chain is to be vacuum degassed.
- the austenitic grain size for all grades is to be 6 or finer in accordance with ASTM E112 or equivalent grain size index in accordance to ISO 643. Measurements for circular sections are to be taken at 1/3 radius
- for grade QR4S and QR5 the following information is to be supplied by the bar manufacturer to the mooring chain manufacturer and the results included in the chain documentation:
  - each heat is to be examined for non-metallic inclusions. The level of micro inclusions is to be quantified and assessed in accordance with recognised national or international standards; to check that inclusion levels are acceptable for the final product
  - a sample from each heat is to be macro etched according to ASTM E381 or equivalent, to check that there is no injurious segregation or porosity
  - hardenability data, according to ASTM A255, or equivalent, is to be supplied with each heat.

#### 2.2.2 Chemical composition

The chemical composition of ladle samples of each heat is to be determined by the steel maker and is to comply with the approved specification.



**2.2.3 Mechanical tests**

- a) Bars of the same nominal diameter are to be presented for test in batches of 50 tonnes or fraction thereof from the same heat. Test specimens are to be taken from material heat treated in the same manner as intended for the finished chain.
- b) Each heat of grade QR3S, QR4, QR4S and QR5 steel is to be tested for hydrogen embrittlement. In case of continuous casting, test samples representing both the beginning and the end of the charge shall be taken. In case of ingot casting, test samples representing two different ingots shall be taken.

Two (2) tensile test specimens shall be taken from the central region of bar material which has been subjected to the heat treatment cycle intended to be used in production. A specimen with a diameter of 20 mm is preferred (consideration will be given to a diameter of 14 mm).

One of the specimen is to be tested within a maximum of 3 hours after machining (for a 14 mm diameter specimen, the time limit is 1½ hour). Where this is not possible, the specimen is to be immediately cooled to –60°C after machining and kept at that temperature for a maximum period of 5 days.

The second specimen is to be tested after baking at 250°C for 4 hours, alternatively 2 hours for 14 mm diameter specimen.

A slow strain rate < 0,0003 s<sup>-1</sup> must be used during the entire test, until fracture occurs (this is approximately 10 minutes for a 20 mm diameter specimen).

Tensile strength, elongation and reduction of area are to be reported. The requirement for the test is:

$$Z_1 / Z_2 \geq 0,85$$

where:

Z<sub>1</sub> : Reduction of area without baking

Z<sub>2</sub> : Reduction of area after baking.

If the requirement  $Z_1 / Z_2 \geq 0,85$  is not met, the bar material may be subjected to a hydrogen degassing treatment after agreement with the Society. New tests shall be performed after degassing.

- c) For all grades, one tensile and three Charpy V-notch specimens are to be taken from each sample selected. The test specimens are to be taken at approx. one-third radius below the surface, as shown in Fig 3.

The results of all tests are to be in accordance with the appropriate requirements of Tab 3

- d) Re-test requirements for tensile tests are given in Ch 2, Sec 2, [1.3].
- e) Re-test requirements for Charpy V-notch impact tests are given in Ch 2, Sec 4, [1.4].
- f) Failure to meet the requirements will result in rejection of the batch represented unless it can be clearly attributable to improper simulated heat treatment.

**2.2.4 Tolerances on dimensions**

The diameter and roundness shall be within the tolerances specified in Tab 4, unless otherwise agreed.

**Table 3 : Mechanical properties of offshore mooring chain and accessories**

Grade	Yield stress (N/mm <sup>2</sup> ) minimum (1)	Tensile strength (N/mm <sup>2</sup> ) minimum (1)	Elongation (%) minimum	Reduction (3) of area (%) minimum	Charpy V-notch impact tests		
					Test temperature (°C) (2)	Average energy J minimum	Average energy flash weld J minimum
QR3	410	690	17	50	0 –20	60 40	50 30
QR3S	490	770	15	50	0 –20	65 45	53 33
QR4	580	860	12	50	–20	50	36
QR4S (4)	700	960	12	50	–20	56	40
QR5 (4)	760	1000	12	50	–20	58	42

(1) Aim value of yield to tensile ratio: 0,92 max.

(2) At the option of the Society, the impact test of grade QR3 and QR3S may be carried out at either 0°C or –20°C.

(3) Reduction of area of cast steel is to be for grades QR3 and QR3S: min. 40%, for QR4, QR4S and QR5: min. 35%, see [2.4.4].

(4) Aim maximum hardness is HB330 for QR4S and HB340 for QR5.

Table 4 : Tolerances on dimensions of bar stock

Nominal diameter (mm)	Tolerance on diameter (mm)	Tolerance on roundness $d_{max} - d_{min}$ (mm)
less than 25	-0 +1,0	0,60
25 - 35	-0 +1,2	0,80
36 - 50	-0 +1,6	1,10
51 - 80	-0 +2,0	1,50
81 - 100	-0 +2,6	1,95
101 - 120	-0 +3,0	2,25
121 - 160	-0 +4,0	3,00
161 - 222	-0 +5,0	4,00

Figure 3 : Sampling of steel bars, forgings and castings

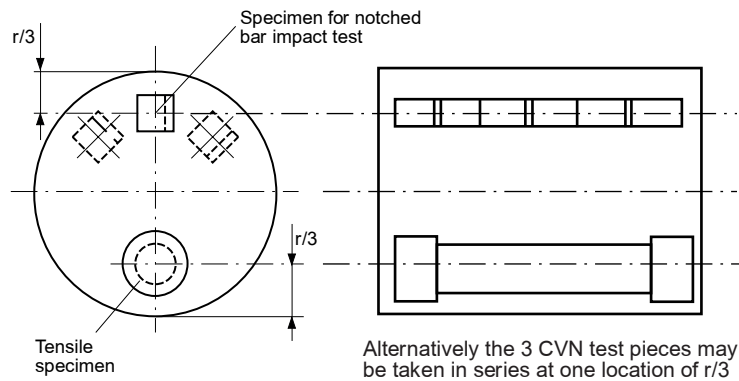

2.2.5 Non-destructive examination and repair

Non-destructive examination is to be performed in accordance with recognized standards such as those indicated below or others recognized standards:

- a) magnetic particle testing (MT) of bars:
  - ASTM E1444 and ISO 9934
- b) magnetic leakage flux testing (MLFT):
  - JIS Z2319
- c) eddy current testing (ET) of bars:
  - ISO 15549.

Non-destructive examination procedures, together with acceptance criteria are to be submitted to the Society.

Manufacturer shall prepare written procedures for NDE. NDE personnel shall be qualified and certified according to ISO 9712, ACCP or equivalent. Personnel qualification to an employer or responsible agency based qualification scheme as SNT-TC-1A may be accepted if the employer's written practice is reviewed and found acceptable and the Level III is ASNT Level III, ISO 9712 Level III or ACCP professional Level III and certified in the applicable method. NDE operators shall be qualified to at least level II.

The manufacturer shall ensure that 100 percent of each bar material intended for either chain or fittings is subjected to ultrasonic examination at an appropriate stage of the manufacture to procedures approved by the Society and to the acceptance criteria required. The bars shall be free of pipe, cracks and flakes. If the end length of the delivered bars is not subject to UT then it must be agreed between the bar supplier and the chain manufacturer of what length of bar is to be removed from the ends. The details are to be documented in the approval of each bar supplier. Phased array UT procedures may be applied, subject to approval by the Society.

The manufacturer shall ensure that 100 percent of each bar material is subjected to examination by magnetic particle (MT) or eddy current (ET) or magnetic leakage flux testing (MLFT) methods. The bars shall be free of injurious surface imperfections such as seams, laps and rolled-in mill scale. Provided that their depth is not greater than 1% of the bar diameter, longitudinal discontinuities may be removed by grinding and blending to a smooth contour.

All bars supplied in a machined (peeled) condition shall be 100% visually inspected. The Society may also require 10% inspected with magnetic particle testing (MT) or eddy current testing (ET) or magnetic leakage flux testing (MLFT), for longitudinal imperfections. The maximum depth of peeling is to be agreed and documented in the approval of each supplier.

The frequency of NDE may be reduced at the discretion of the Society provided it is verified by statistical means that the required quality is consistently achieved.

Weld repair of bar is not permitted.

### 2.2.6 Marking

Each bar is to be stamped with the steel grade designation and the charge number (or a code indicating the charge number) on one of the end surfaces. Other marking methods may be accepted subject to agreement.

## 2.3 Forged steel

### 2.3.1 Manufacture

- a) forged steels used for the manufacture of accessories must be in compliance with approved specifications and the submitted test reports approved by the Society. Steel is to be manufactured by basic oxygen, electric furnace or such other process as may be specially approved. All steel is to be killed and fine grain treated.
- b) steels for forgings intended for QR4S and QR5 chain is to be vacuum degassed
- c) the austenitic grain size for all steel grades is to be 6 or finer in accordance with ASTM E112 or equivalent grain size index in accordance to ISO 643. Measurements for circular sections are to be taken at 1/3 radius. Measurements for non-circular sections are to be taken at 1/4t
- d) for steels intended for QR4S and QR5 accessories the following information is to be supplied by the steel manufacturer to the mooring accessory manufacturer and the results included in the accessory documentation:
  - each heat is to be examined for non-metallic inclusions. The level of micro inclusions is to be quantified and assessed in accordance with recognised national or international standards; to check that inclusion levels are acceptable for the final product
  - a sample from each heat is to be macro etched according to ASTM E381 or equivalent, to check that there is no injurious segregation or porosity
  - hardenability data, according to ASTM A255, or equivalent, is to be supplied with each heat.

### 2.3.2 Chemical composition

The chemical composition of ladle samples of each heat is to be determined by the steel maker and is to comply with the approved specification.

### 2.3.3 Heat treatment

Finished forgings are to be properly heat treated in compliance with specifications submitted and approved.

### 2.3.4 Mechanical properties

The forgings must comply with the mechanical properties given in Tab 3, when properly heat treated.

### 2.3.5 Mechanical tests

- a) For test sampling, forgings of similar dimensions (diameters do not differ by more than 25mm) originating from the same heat treatment charge and the same heat of steel are to be combined into one test unit. From each test unit one tensile and three impact test specimens are to be taken and tested. For the location of the test specimens see Fig 3.
- b) Each heat of grade QR3S, QR4, QR4S and QR5 steel is to be tested for hydrogen embrittlement. In case of continuous casting, test samples representing both the beginning and the end of the charge shall be taken. In case of ingot casting, test samples representing two different ingots shall be taken.

Two (2) tensile test specimens shall be taken from the central region of forged material which has been subjected to the heat treatment cycle intended to be used in production. A specimen with a diameter of 20 mm is preferred (consideration will be given to a diameter of 14 mm).

One of the specimen is to be tested within a maximum of 3 hours after machining (for a 14 mm diameter specimen, the time limit is 1½ hours). Where this is not possible, the specimen is to be immediately cooled to -60°C after machining and kept at that temperature for a maximum period of 5 days.

The second specimen is to be tested after baking at 250°C for 4 hours, alternatively 2 hours for 14 mm diameter specimen.

A slow strain rate  $< 0,0003 \text{ s}^{-1}$  must be used during the entire test, until fracture occurs (this is approximately 10 minutes for a 20 mm diameter specimen).

Tensile strength, elongation and reduction of area are to be reported. The requirement for the test is:

$$Z_1 / Z_2 \geq 0,85$$

where:

$Z_1$  : Reduction of area without baking

$Z_2$  : Reduction of area after baking.

If the requirement  $Z_1 / Z_2 \geq 0,85$  is not met, the bar material may be subjected to a hydrogen degassing treatment after agreement with the Society. New tests shall be performed after degassing.

**2.3.6 Non-destructive examination and repair**

Non-destructive examination is to be performed in accordance with recognized standards such as those indicated below or others recognized standards:

- a) magnetic particle testing (MT) of forgings:
  - EN 10228-1, ASTM A275, using wet continuous magnetization technique.
- b) ultrasonic testing (UT) of forgings:
  - EN 10228-3, ASTM A388, ISO 13588.

Non-destructive examination procedures, together with acceptance criteria are to be submitted to the Society.

Manufacturer shall prepare written procedures for NDE. NDE personnel shall be qualified and certified according to ISO 9712, ACCP or equivalent. Personnel qualification to an employer or responsible agency based qualification scheme as SNT-TC-1A may be accepted if the employer's written practice is reviewed and found acceptable and the Level III is ASNT Level III, ISO 9712 Level III or ACCP professional Level III and certified in the applicable method. NDE operators shall be qualified to at least level II.

Each forging is to be subjected to 100 percent ultrasonic examination at an appropriate stage of manufacture and in compliance with the standard submitted and approved.

Defects on non-machined surfaces may be removed by grinding to a depth of 5% of the nominal diameter. Grinding is not permitted on machined surfaces, except for slight inspection grinding on plane surfaces to a maximum depth of 0,8 mm in order to investigate spurious indications.

Welding repairs are not permitted.

**2.3.7 Marking**

Marking is to be similar to that specified in [2.2.6].

**2.4 Cast steel****2.4.1 Manufacture**

- a) cast steel used for the manufacture of accessories must be in compliance with approved specifications and the submitted test reports approved by the Society. Steel is to be manufactured by basic oxygen, electric furnace or such other process as may be specially approved. All steel is to be killed and fine grain treated
- b) steels for castings intended for QR4S and QR5 chain is to be vacuum degassed
- c) the austenitic grain size for all steel grades is to be 6 or finer in accordance with ASTM E112 or equivalent grain size index in accordance to ISO 643. Measurements for circular sections are to be taken at 1/3 radius. Measurements for non-circular sections are to be taken at 1/4t
- d) for steels intended for QR4S and QR5 accessories the following information is to be obtained and the results included in the accessory documentation:
  - each heat is to be examined for non-metallic inclusions. The level of micro inclusions is to be quantified and assessed in accordance with recognised national or international standards; to check that inclusion levels are acceptable for the final product
  - a sample from each heat is to be macro etched according to ASTM E381 or equivalent, to check that there is no injurious segregation or porosity
  - hardenability data, according to ASTM A255, or equivalent, is to be supplied with each heat.

**2.4.2 Chemical composition**

The chemical composition of ladle samples of each heat is to be determined by the steel maker and is to comply with the approved specification.

**2.4.3 Heat treatment**

All castings are to be properly heat treated in compliance with specifications submitted and approved.

**2.4.4 Mechanical properties**

The castings must comply with the mechanical properties given in Tab 3. The acceptance requirement for reduction of area is, however, reduced to 40% for grades QR3 and QR3S and to 35% for grades QR4, QR4S and QR5.

**2.4.5 Mechanical tests**

For test sampling, castings of similar dimensions originating from the same heat treatment charge and the same heat of steel are to be combined into one test unit. From each test unit one tensile and three impact test specimens are to be taken and tested. For the location of the test specimens see Fig 3.

#### 2.4.6 Non-destructive examination and repair

Non-destructive examination is to be performed in accordance with recognized standards such as those indicated below or others recognized standards:

- a) magnetic particle testing (MT) of castings:
  - ASTM E709, using wet continuous magnetization technique.
- b) ultrasonic testing (UT) of castings:
  - ASTM A609, ISO 13588.

Non-destructive examination procedures, together with acceptance criteria are to be submitted to the Society.

Manufacturer shall prepare written procedures for NDE. NDE personnel shall be qualified and certified according to ISO 9712, ACCP or equivalent. Personnel qualification to an employer or responsible agency based qualification scheme as SNT-TC-1A may be accepted if the employer's written practice is reviewed and found acceptable and the Level III is ASNT Level III, ISO 9712 Level III or ACCP professional Level III and certified in the applicable method. NDE operators shall be qualified to at least level II.

Each casting is to be subjected to 100 percent ultrasonic examination in compliance with the standard submitted and approved.

Defects on non-machined surfaces may be removed by grinding to a depth of 5% of the nominal diameter. Grinding is not permitted on machined surfaces, except for slight inspection grinding on plane surfaces to a maximum depth of 0,8 mm in order to investigate spurious indications.

Where the repair entails removal of more than 5% of the nominal diameter or thickness, the defective area shall be repaired by welding. The excavations shall be suitably shaped to allow good access for welding. The resulting grooves shall be subsequently ground smooth and complete elimination of the defective material shall be verified by non-destructive examination.

Weld repairs are classified as major or minor. A weld repair is considered major when the depth of the groove prepared for welding exceeds 25% of the diameter/thickness or 25mm, whichever is smaller. All other weld repairs are considered minor.

Minor and major weld repairs must be recorded on sketches or photographs showing the extent and positions of the repairs.

Before major welding repair is started, full details of the extent and location of the repair, the proposed welding procedure specification, heat treatment and subsequent procedure are to be submitted to the Society for approval.

A grain refining heat treatment shall be given to the whole casting prior to major weld repairs. A post weld heat treatment or repeat of original heat treatment of castings shall be carried out.

All weld repairs shall be done by qualified welders using qualified procedures. Welders shall be qualified according to ISO 9606, ASME IX, ASTM A488 or other recognized standard. Procedures shall be qualified according to ISO 15614, ASME IX, ASTM A488 or other recognized standard with the following additional requirements:

- a) Charpy V notch impact tests with notch locations in weld metal, fusion line and heat affected zone +2 mm and +5 mm from fusion line, respectively
- b) test results shall meet the requirements specified for the parent metal.

#### 2.4.7 Marking

Marking is to be similar to that specified in [2.2.6].

### 2.5 Materials for studs

**2.5.1** Studs intended for stud link chain cable are to be made of steel corresponding to that of the chain or in compliance with specifications submitted and approved. In general, the carbon content should not exceed 0,25 percent if the studs are to be welded in place.

## 3 Design and manufacture

### 3.1 Design

**3.1.1** Drawings accompanied by design calculations, giving detailed design of chain and accessories made by or supplied through the chain manufacturer are to be submitted for approval. Typical designs are given in ISO 1704:2008.

For studless chain the shape and proportions are to comply with the requirements of this Article. Other studless proportions are to be specially approved. It should be considered that new or non-standard designs of chain, shackles or fittings, may require a fatigue analysis and possible performance, fatigue or corrosion fatigue testing.

In addition, for stud link chain, drawings showing the detailed design of the stud shall be submitted for information. The stud shall give an impression in the chain link which is sufficiently deep to secure the position of the stud, but the combined effect of shape and depth of the impression shall not cause any harmful notch effect or stress concentration in the chain link.

Machining of Kenter shackles shall result in fillet radius min. 3 percent of nominal diameter.

**3.2 Chain cable manufacturing process**

**3.2.1 General**

Offshore mooring chains shall be manufactured in continuous lengths by flash butt welding and are to be heat treated in a continuous furnace; batch heat treatment is not permitted, except in special circumstances where short lengths of chain are delivered, such as chafing chain as specified in [6].

The use of joining shackles to replace defective links is subject to the written approval of the end purchaser in terms of the number and type permitted. The use of connecting common links is restricted to 3 links in each 100 m of chain.

**3.2.2 Chain cable manufacturing process records**

Records of bar heating, flash welding and heat treatment shall be made available for inspection by the Surveyor.

**3.2.3 Bar heating**

Bars for links shall be heated by electric resistance, induction or in furnace.

For electric resistance heating or induction heating, the heating phase shall be controlled by an optical heat sensor. The controller shall be checked at least once every 8 hours and records made.

For furnace heating, the heat shall be controlled and the temperature continuously recorded using thermocouples in close proximity to the bars. The controls shall be checked at least once every 8 hours and records made.

**3.2.4 Flash welding of chain cable**

The following welding parameters shall be controlled during welding of each link:

- a) platen motion
- b) current as a function of time
- c) hydraulic pressure.

The controls shall be checked at least every 4 hours and records made.

**3.2.5 Heat treatment of chain cable**

Chain shall be austenitized, above the upper transformation temperature, at a combination of temperature and time within the limits established.

When applicable, chain shall be tempered at a combination of temperature and time within the limits established. Cooling after tempering shall be appropriate to avoid temper embrittlement.

Temperature and time or temperature and chain speed shall be controlled and continuously recorded.

Grain determination shall be made for the final product. The austenitic grain size for all grades is to be 6 or finer in accordance with ASTM E112 or equivalent grain size index in accordance to ISO 643. Measurements for circular sections are to be taken at surface, 1/3 radius and centre for the base material, HAZ and weld.

**3.2.6 Mechanical properties**

The mechanical properties of finished chain and accessories are to be in accordance with Tab 3. For the location of test specimens see Fig 3 and Fig 4.

**3.2.7 Proof and breaking test loads**

Chains and accessories are to withstand the proof and break test loads given in Tab 5.

**3.2.8 Freedom from defects**

All chains are to have a workmanlike finish consistent with the method of manufacture and be free from defects. Each link is to be examined in accordance with [4.5] using approved procedures.

**Figure 4 : Sampling of chain links**

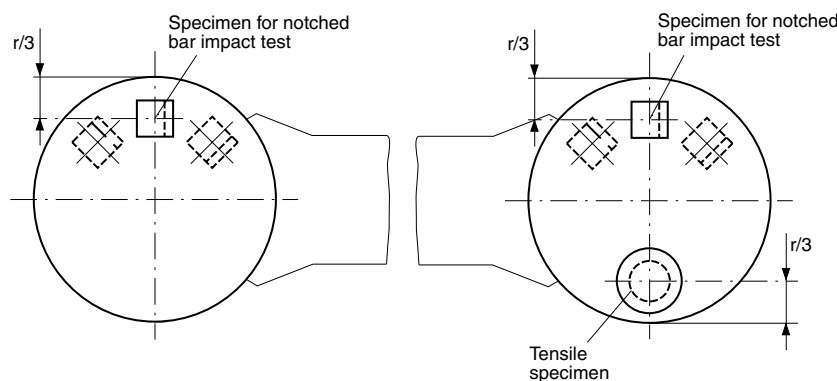



**Table 5 : Formulas for proof and break test loads, weight and length over 5 links**

Test load, in kN	Stud link chains				
	Grade QR3	Grade QR3S	Grade QR4	Grade QR4S	Grade QR5
Proof	0,0148 d <sup>2</sup> (44 – 0,08 d)	0,0180 d <sup>2</sup> (44 – 0,08 d)	0,0216 d <sup>2</sup> (44 – 0,08 d)	0,0240 d <sup>2</sup> (44 – 0,08 d)	0,0251 d <sup>2</sup> (44 – 0,08 d)
Break	0,0223 d <sup>2</sup> (44 – 0,08 d)	0,0249 d <sup>2</sup> (44 – 0,08 d)	0,0274 d <sup>2</sup> (44 – 0,08 d)	0,0304 d <sup>2</sup> (44 – 0,08 d)	0,0320 d <sup>2</sup> (44 – 0,08 d)

Test load, in kN	Studless chains				
	Grade QR3	Grade QR3S	Grade QR4	Grade QR4S	Grade QR5
Proof	0,0148 d <sup>2</sup> (44 – 0,08 d)	0,0174 d <sup>2</sup> (44 – 0,08 d)	0,0192 d <sup>2</sup> (44 – 0,08 d)	0,0213 d <sup>2</sup> (44 – 0,08 d)	0,0223 d <sup>2</sup> (44 – 0,08 d)
Break	0,0223 d <sup>2</sup> (44 – 0,08 d)	0,0249 d <sup>2</sup> (44 – 0,08 d)	0,0274 d <sup>2</sup> (44 – 0,08 d)	0,0304 d <sup>2</sup> (44 – 0,08 d)	0,0320 d <sup>2</sup> (44 – 0,08 d)
Chain weight, in kg/m	Stud link = 0,0219 d <sup>2</sup>				
	Studless chain: weight calculations for each design are to be submitted				
Pitch length	Five link measures				
Minimum	22 d				
Maximum	22,55 d				
<b>Note 1:</b> d	: Nominal diameter of chain, in mm				

**3.2.9 Dimensions and dimensional tolerances**

The shape and proportion of links and accessories must conform to ISO 1704 or the designs specially approved.

The following tolerances are applicable to links:

a) The negative tolerance on the nominal diameter measured at the crown:

- up to 40 mm nominal diameter: – 1 mm
- over 40 up to 84 mm nominal diameter: – 2 mm
- over 84 up to 122 mm nominal diameter: – 3 mm
- over 122 up to 152 mm nominal diameter: – 4 mm
- over 152 up to 184 mm nominal diameter: – 6 mm
- over 184 up to 222 mm nominal diameter: – 7,5 mm.

Note 1: The cross sectional area at the crown must have no negative tolerance. For diameters of 20 mm or greater, the plus tolerance may be up to 5 percent of the nominal diameter. For diameters less than 20 mm the plus tolerance is to be agreed with the Society at time of approval.

Note 2: The cross sectional area at the crown is to be calculated using the average of the diameters with negative tolerance and plus tolerance, measurements are to be taken from at least 2 locations approximately 90 degrees apart.

The cross sectional area at the crown must have no negative tolerance.

b) Diameter measured at locations other than the crown:

The diameter is to have no negative tolerance. The plus tolerance may be up to 5 percent of the nominal diameter except at the butt weld where it is to be in accordance to manufacturer’s specification, which is to be agreed with the Society. For diameters less than 20mm, the plus tolerance is to be agreed with the Society at time of approval.

- c) The allowable manufacturing tolerance on a length of five links is + 2,5 percent, but is not to be negative.
- d) All other dimensions are subject to a manufacturing tolerance of ± 2,5 percent, provided always that all parts fit together properly.
- e) The tolerances for stud link and studless common links are to be measured in accordance with Tab 6 and Tab 7.
- f) For stud link chains studs must be located in the links centrally and at right angles to the sides of the link. The tolerances in Tab 6 and Tab 7 are acceptable provided that the stud fits snugly and its ends lie flush against the inside of the link.

**Table 6 : Stud link common link, proportions dimensions and tolerances**

Designation (1)	Description	Nominal dimension of the link	Minus tolerance	Plus tolerance
a	Link length	6 d	0,15 d	0,15 d
b	Link half length	a*/2	0,1 d	0,1 d
c	Link width	3,6 d	0,09 d	0,09 d
e	Stud angular misalignment	0 degree	4 degrees	4 degrees
R	Inner radius	0,65 d	0	-

(1) Dimension designation is shown in Fig 5.  
d : Nominal diameter of chain, in mm.  
a\* : Actual link length.

**Figure 5 : Stud link**

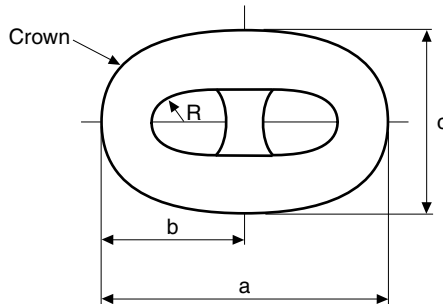
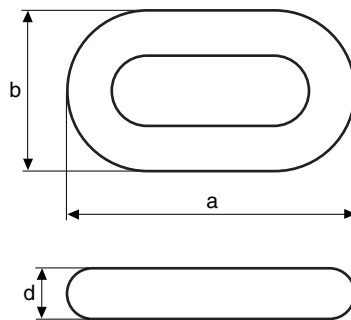

**Table 7 : Studless common link, proportions dimensions and tolerances**

Designation (1)	Description	Nominal dimension of the link	Minus tolerance	Plus tolerance
a	Link length	6 d	0,15 d	0,15 d
b	Link width	3,35 d	0,09 d	0,09 d
R	Inner radius	0,60 d	0	-

(1) Dimension designation is shown in Fig 6.  
d : Nominal diameter of chain, in mm.  
**Note 1:** Other dimension ratios are subject to special approval.

**Figure 6 : Studless**



**3.2.10 Stud link chain - welding of studs**

A welded stud may be accepted for grades QR3 and QR3S chains. Welding of studs in grades QR4, QR4S and QR5 chain is not permitted unless specially approved.

Where studs are welded into the links this is to be completed before the chain is heat treated.

The stud ends must be a good fit inside the link and the weld is to be confined to the stud end opposite to the flash butt weld. The full periphery of the stud end is to be welded unless otherwise approved.

Welding of studs both ends is not permitted unless specially approved.

The welds are to be made by qualified welders using an approved procedure and low-hydrogen approved consumables.

The size of the fillet weld shall as a minimum be as per API Specification 2F.



The welds are to be of good quality and free from defects such as cracks, lack of fusion, gross porosity and undercuts exceeding 1 mm.

All stud welds shall be visually examined. At least 10% of all stud welds within each length of chain shall be examined by dye penetrant or magnetic particles after proof testing. If cracks or lack of fusion are found, all stud welds in that length are to be examined.

### **3.2.11 Connecting common links (splice links)**

Single links to substitute for test links or defective links without the necessity for re-heat treatment of the whole length are to be made in accordance with an approved procedure. Separate approvals are required for each grade of chain and the tests are to be made on the maximum size of chain for which approval is sought.

Manufacture and heat treatment of connecting common link is not to affect the properties of the adjoining links. The temperature reached by these links is nowhere to exceed 250°C.

Each link is to be subjected to the appropriate proof load and non-destructive examination as detailed in Tab 5 and in [4.5]. A second link shall be made identical to the connecting common link; the link shall be tested and inspected as per [4.4] and [4.5].

Each connecting common link is to be marked either; on the stud for stud link chain or, on the outer straight length on the side opposite the flash butt weld for studless chain. This marking is to be in accordance with [4.7] plus a unique number for the link. The adjoining links are also to be marked on the studs or straight length as above.

## **4 Testing and inspection of finished chain**

### **4.1 General**

**4.1.1** This Article applies to but not limited to finished chain cable such as common stud and studless links, end links, enlarged end links and connecting common links (splice links).

All chain is to be subjected to proof load tests, sample break load tests and sample mechanical tests after final heat treatment in the presence of a Surveyor. Where the manufacturer has a procedure to record proof loads and the Surveyor is satisfied with the adequacy of the recording system, he need not witness all proof load tests. The Surveyor is to satisfy himself that the testing machines are calibrated and maintained in a satisfactory condition.

Prior to inspection the chain is to be free from scale, paint or other coating and is to have a suitably prepared surface as per applied NDE testing standard. The chain shall be sand or shot blast to meet this requirement.

### **4.2 Proof and break load tests**

**4.2.1** The entire length of chain shall withstand the proof load specified in Tab 5 without fracture and shall not crack in the flash weld. The load applied shall not exceed the proof load by more than 10% when stretching the chain. Where plastic straining is used to set studs, the applied load is not to be greater than that qualified in approval tests.

**4.2.2** A break-test specimen consisting of at least 3 links is to be either taken from the chain or produced at the same time and in the same manner as the chain. The test frequency is to be based on tests at sampling intervals according to Tab 8 provided that every cast is represented. Each specimen shall be capable of withstanding the break load specified without fracture and shall not crack in the flash weld. It shall be considered acceptable if the specimen is loaded to the specified value and maintained at that load for 30 seconds.

**4.2.3** For chain diameters over 100 mm, alternative break test proposals to the above break test will be considered whereby a one link specimen is used. Alternatives are to be approved by the Society, every heat is to be represented, the test frequency is to be in accordance with Tab 8, and it is to be demonstrated and proven that the alternative test represents an equivalent load application to the three links test.

**4.2.4** If the loading capacity of the testing machine is insufficient, an alternative load testing machine is to be used that does have sufficient capacity (e.g. two loading machines in parallel) provided the testing and calibration procedure are agreed with the Society.

### **4.3 Dimensions and dimensional tolerances**

**4.3.1** After proof load testing measurements are to be taken on at least 5 per cent of the links in accordance with [3.2.9].

**4.3.2** The entire chain is to be checked for the length, five links at a time. By the five link check the first five links shall be measured. From the next set of five links, at least two links from the previous five links set shall be included. This procedure is to be followed for the entire chain length. The measurements are to be taken preferably while the chain is loaded to 5-10% of the minimum proof load. The tolerances for the 5 link measurements are indicated in Tab 5, any deviations from the 5 link tolerances are to be agreed by the client and the Society. The links held in the end blocks may be excluded from this measurement.

**4.3.3** Chain dimensions are to be recorded and the information retained on file.

**Table 8 : Frequency of break and mechanical tests**

Nominal chain diameter (mm)	Maximum sampling interval (m)
Min - 48	91
49 - 60	110
61 - 73	131
74 - 85	152
86 - 98	175
99 - 111	198
112 - 124	222
125 - 137	250
138 - 149	274
150 - 162	297
163 - 175	322
176 - 186	346
187 - 198	370
199 - 210	395
211 - 222	420

**4.4 Mechanical tests**

**4.4.1** Links of samples detached from finished, heat treated chain shall be sectioned for determination of mechanical properties. A test unit shall consist of one tensile and nine impact specimens. The tensile specimen shall be taken in the side opposite the flash weld. Three impact specimens shall be taken across the flash weld with the notch centered in the middle. Three impact specimens shall be taken across the unwelded side and three impact specimens shall be taken from the bend region.

**4.4.2** The test frequency is to be based on tests at sampling intervals according to Tab 8 provided that every cast is represented. Mechanical properties shall be as specified in Tab 3.

**4.4.3** The frequency of impact testing in the bend may be reduced at the discretion of the Society provided it is verified by statistical means that the required toughness is consistently achieved.

**4.4.4** Hardness tests are to be carried out on finished chain. The frequency and locations are to be agreed by the Society. The recorded values are for information only and used as an additional check to verify that the heat treatment process has been stable during the chain production.

**4.5 Non-destructive examination after proof load testing**

**4.5.1** All surfaces of every link shall be visually examined. Burrs, irregularities and rough edges shall be contour ground. Links shall be free from mill defects, surface cracks, dents and cuts, especially in the vicinity where gripped by clamping dies during flash welding. Studs shall be securely fastened. Chain is to be positioned in order to have good access to all surfaces. In order to allow optimal access to the surface area it is recommended that chain be hung in the vertical position, however access to inspect the interlink area may only be possible with the chain in the horizontal position.

**4.5.2** Testing is to be performed in accordance with a recognized standard and the procedures, together with acceptance criteria are to be submitted to the Society for review.

Manufacturer shall prepare written procedures for NDE. NDE personnel shall be qualified and certified according to ISO 9712, ACCP or equivalent. Personnel qualification to an employer or responsible agency based qualification scheme as SNT-TC-1A may be accepted if the employer’s written practice is reviewed and found acceptable and the Level III is ASNT Level III, ISO 9712 Level III or ACCP professional Level III and certified in the applicable method. NDE operators shall be qualified to at least level II.

**4.5.3** Magnetic particles shall be employed to examine the flash welded area including the area gripped by the clamping dies. Procedures are to be submitted to the Society for approval. Procedures and equipment in accordance with those approved shall be used.

Frequency of examination shall be every link. Additionally, 10% of links are to be tested on all accessible surfaces.

Link surface at the flash weld shall be free from cracks, lack of fusion and gross porosity.

Testing shall be performed in accordance with ASTM E709 or another recognized standard (e.g. ISO 9934) using wet continuous fluorescent magnetization technique. Non fluorescent techniques can be accepted in special cases where the standard inspection procedures are impractical.

Links shall be free from:

- relevant linear indications exceeding 1,6 mm in transverse direction
- relevant linear indications exceeding 3,2 mm in longitudinal direction
- relevant non-linear indications exceeding 4,8 mm.

**4.5.4** Ultrasonics shall be employed to examine the flash weld fusion. Procedures are to be submitted to the Society for approval. Procedures and equipment in accordance with those approved shall be used. On-site calibration standards for chain configurations shall be approved.

Frequency of examination shall be every link.

The flash weld shall be free from defects causing ultrasonic back reflections equal to or greater than the calibration standard. The flash butt welds shall be ultrasonic tested (UT) in accordance with ASTM E587 or another recognized standard using single probe, angle-beam shear waves in the range from 45 to 70°.

Single probe technique has limitations as far as testing of the central region is concerned and the flash weld imperfections such as flat spots may have poor reflectivity. Where it is deemed necessary, detectability of imperfections may need to be carried out by using a tandem technique, TOFD or phased array.

**4.5.5** Stud welds, if used, shall be visually inspected. The toes of the fillets shall have a smooth transition to the link with no undercuts exceeding 1,0 mm. Additionally, at least 10% of the stud welds distributed through the length shall be dye penetrant tested according to ASTM E1417 or magnetic particle tested according to ASTM E1444 or other recognized standard.

Cracks, lack of fusion or gross porosity are not acceptable. If defects are found, testing shall be extended to all stud welds in that length.

## **4.6 Retest, rejection and repair criteria**

**4.6.1** If the length over 5 links is short, the chain may be stretched by loading above the proof test load specified provided that the applied load is not greater than that approved and that only random lengths of the chain need stretching.

If the length exceeds the specified tolerance, the overlength chain links shall be cut out and [4.6.2] shall apply.

**4.6.2** If single links are found to be defective or do not meet other applicable requirements, defective links may be cut out and a connecting common link inserted in their place. The individual heat treatment and inspection procedure of connecting common links is subject to the Society's approval.

Other methods for repair are subject to the written approval of the Society and the end purchaser. Weld repair of chain is not permitted.

**4.6.3** If a crack, cut or defect in the flash weld is found by visual or magnetic particle examination, it shall be ground down no more than 5% of the link diameter in depth and streamlined to provide no sharp contours. The final dimensions must still conform to the agreed standard.

**4.6.4** If indications of interior of flash weld defects in reference to the accepted calibration standards are detected during ultrasonic examination, [4.6.2] shall apply.

**4.6.5** If link diameter, length, width and stud alignment do not conform to the required dimensions, these shall be compared to the dimensions of 40 more links; 20 on each side of the affected link. If a single particular dimension fails to meet the required dimensional tolerance in more than 2 of the sample links, all links shall be examined and [4.6.2] shall apply.

**4.6.6** If a break load test fails, a thorough examination with the Surveyor informed in a timely manner is to be carried out to identify the cause of failure. Two additional break test specimens representing the same sampling length of chain are to be subjected to the break load test. Based upon satisfactory results of the additional tests and the results of the failure investigation, it will be decided what lengths of chain can be accepted. Failure of either or both additional tests will result in rejection of the sampling length of chain represented and [4.6.2] shall apply.

**4.6.7** If a link fails during proof load testing, a thorough examination with the Surveyor informed in a timely manner is to be carried out to identify the probable cause of failure of the proof test. In the event that two or more links in the proof loaded length fail, that section of proof loaded length is to be rejected. The above failure investigation is to be carried out especially with regard to the presence in other lengths of factors or conditions thought to be causal to failure.

**4.6.8** In addition to the above failure investigation, a break test specimen is to be taken from each side of the one failed link, and subjected to the breaking test. Where multiple chains are produced simultaneously it is recognised that the preceding flash butt welded link and subsequent flash butt welded link will be on an alternative chain length or the other end of the chain length. In such cases the Society may require that two additional break tests are to be taken from the lengths of chain that include the preceding and subsequent welded links. Based upon satisfactory results of both break tests and the results of the failure investigation, it will be decided what length of chain can be considered for acceptance. Failure of either or both breaking tests will result in rejection of the same proof loaded length.

Replacement of defective links is to be in accordance with [4.6.2].

If the investigation identifies defects in the flash butt weld or a lower strength flash weld “a glue-weld” is found, additional NDE such as phased array UT is to be carried out to identify if other links are affected. A full assessment of the flash butt welding machine is to be carried out, together with assessment of the condition of the bar ends prior to welding.

**4.6.9** Re-test requirements for tensile tests are given in Ch 2, Sec 2, [1.3]. Failure to meet the specified requirements of either or both additional tests will result in rejection of the sampling length of chain represented and [4.6.2] shall apply.

**4.6.10** Re-test requirements for Charpy V-notch impact tests are given in Ch 2, Sec 4, [1.4].

Failure to meet the requirements will result in rejection of the sampling length represented and [4.6.2] shall apply.

### 4.7 Marking

**4.7.1** The chain shall be marked at the following places:

- at each end
- at intervals not exceeding 100 m
- on connecting common links
- on links next to shackles or connecting common links.

**4.7.2** All marked links shall be stated on the certificate, and the marking shall make it possible to recognize leading and tail end of the chain. In addition to the above required marking, the first and last common link of each individual charge used in the continuous length shall be traceable and adequately marked.

The marking shall be permanent and legible throughout the expected lifetime of the chain.

**4.7.3** The chain shall be marked on the studs as follows:

- chain grade
- certificate No.
- Society's stamp.

**4.7.4** The Certificate number may be exchanged against an abbreviation or equivalent. If so, this shall be stated in the certificate.

**4.7.5** The chain certificate shall contain information on number and location of connecting common links. The certificate number and replacement link number may be exchanged against an abbreviation or equivalent. If so, this shall be stated in the certificate.

### 4.8 Documentation

**4.8.1** A complete Chain Inspection and Testing Report in booklet form shall be provided by the chain manufacturer for each continuous chain length. This booklet shall include all dimensional checks, test and inspection reports, NDT reports, process records, photographs as well as any nonconformity, corrective action and repair work.

**4.8.2** Individual certificates are to be issued for each continuous single length of chain.

**4.8.3** All accompanying documents, appendices and reports shall carry reference to the original certificate number.

**4.8.4** The manufacturer will be responsible for storing, in a safe and retrievable manner, all documentation produced for a period of at least 10 years.

## 5 Testing and inspection of accessories

### 5.1 General

**5.1.1** This Article applies to but is not limited to mooring equipment accessories such as detachable connecting links (shackles), detachable connecting plates (triplates), end shackles, swivels and swivel shackles and subsea connectors.

**5.1.2** All accessories are to be subjected to proof load tests, sample break load tests and sample mechanical tests after final heat treatment in the presence of a Surveyor. Where the manufacturer has a procedure to record proof loads and the Surveyor is satisfied with the adequacy of the recording system, he needs not witness all proof load tests. The Surveyor is to satisfy himself that the testing machines are calibrated and maintained in a satisfactory condition.

Prior to testing and inspection the chain accessories are to be free from scale, paint or other coating.

**5.1.3** For accessory production a Manufacturing Procedure Specification (MPS) is to be submitted to the Society that details all critical aspects of accessory production, casting, forging, heat treating (including arrangement and spacing of components in the heat treatment furnaces), quenching, mechanical testing, proof and break loading and non-destructive examination.

## 5.2 Proof and break load tests

**5.2.1** All accessories are to be subjected to the proof load specified for the corresponding stud link chain.

**5.2.2** Chain accessories are to be tested at the break load prescribed for the grade and size of chain for which they are intended. At least one accessory out of every batch or every 25 accessories, whichever is less, is to be tested. For individually produced, individually heat treated, accessories or accessories produced in small batches (less than 5), alternative testing will be subject to special consideration. Alternative testing is to be approved by the Society and the following additional conditions may apply:

- a) alternative testing is described in a written procedure and manufacturing procedure specification (MPS)
- b) a finite element analysis is provided at the break load and demonstrates that the accessory has a safety margin over and above the break load of the chain
- c) strain age testing, as per approved procedure by the Society, is carried out on the material grade produced to the same parameters at the time of qualification
- d) if an accessory is of a large size that will make heat treating in batches unfeasible or has a unique design, strain gauges are to be applied during the proof and break load tests during initial qualification and during production. The strain gauge results from production are to be comparable with the results from qualification.

**5.2.3** A batch is defined as accessories that originate from the same heat treatment charge and the same heat of steel. Refer to [2.3] and [2.4].

**5.2.4** The accessories which have been subjected to the break load test are to be destroyed and not used as part of an outfit, with the exceptions given in [5.2.5].

**5.2.5** Where the accessories are of increased dimension or alternatively a material with higher strength characteristics is used, they may be included in the outfit at the discretion of the Society, provided that:

- a) the accessories are successfully tested at the prescribed breaking load appropriate to the chain for which they are intended, and
- b) it is verified by procedure tests that such accessories are so designed that the breaking strength is not less than 1,4 times the prescribed breaking load of the chain for which they are intended
- c) strain age properties have been carried out on the material grade produced to the same parameters
- d) strain gauges are to be applied during the break load test in the high stress locations to monitor that the strains stay within allowable limits.

## 5.3 Dimensions and tolerances on dimensions

**5.3.1** At least one accessory (of the same type, size and nominal strength) out of 25 is to be checked for dimensions after proof load testing. The manufacturer is to provide a statement indicating compliance with the purchaser's requirements.

**5.3.2** The following tolerances are applicable to accessories:

- a) nominal diameter: + 5 percent, -0 percent
- b) other dimensions:  $\pm 2\frac{1}{2}$  percent

These tolerances do not apply to machined surfaces.

## 5.4 Mechanical tests

**5.4.1** Accessories are to be subjected to mechanical testing as described in [2.3] and [2.4]. Mechanical tests are to be taken from proof loaded full size accessories that have been heat treated with the production accessories they represent.

At least one accessory out of every batch or every 25 accessories, whichever is less, is to be tested.

Hardness tests are to be carried out on finished accessories. The frequency and locations are to be agreed by the Society. The recorded values are for information only and used as an additional check to verify that the heat treatment process has been stable during the accessory production.

The use of separate representative coupons is not permitted except as indicated in [5.4.5] below.

**5.4.2** Test location of forged shackle bodies and forged Kenter shackles are to have a set of three impact tests and a tensile test taken from the crown of the shackle. Tensile tests on smaller diameter shackles can be taken from the straight part of the shackle, where the geometry does not permit a tensile specimen from the crown. The tensile properties and impact values are to meet the requirements of Tab 3, with the Charpy pieces on the outside radius.

**5.4.3** The locations of mechanical tests of cast shackles and cast Kenter shackles can be taken from the straight part of the accessory. The tensile properties and impact values are to meet the requirements of Tab 3 in the locations specified in Fig 3.

**5.4.4** The locations of mechanical tests of other accessories with complex geometries are to be agreed with the Society.

For non-circular sections,  $1/4t$  (thickness) from the surface is considered appropriate.

Rolled plates are to be tested to the Standard to which they are produced.

**5.4.5** For individually produced, individually heat treated, accessories or accessories produced in small batches, (less than 5), alternative testing can be proposed to the Society. Each proposal for alternative testing is to be detailed in a written procedure and submitted to the Society, and the following additional conditions may apply:

- a) if separately forged or cast coupons are used, they are to have a cross-section and, for forged coupon, a reduction ratio similar to that of the accessories represented, and are to be heat treated in the same furnace and quenched in the same tank at the same time, as the actual forgings or castings. Thermocouples are to be attached to the coupon and to the accessories
- b) if separately forged or cast coupons are agreed, it is to be verified by procedure test that coupon properties are representative of accessory properties.

**5.4.6** A batch is defined as accessories that originate from the same heat treatment charge and the same heat of steel. refer to [2.3] and [2.4].

**5.4.7** Mechanical tests of pins are to be taken as per Fig 3 from the mid length of a sacrificial pin of the same diameter as the final pin. For oval pins, the diameter taken is to represent the smaller dimension. Mechanical tests may be taken from an extended pin of the same diameter as the final pin that incorporates a test prolongation and a heat treatment buffer prolongation, where equivalence with mid length test values have been established. The length of the buffer is to be at least equal to 1 pin diameter dimension which is removed after the heat treatment cycle is finished. The test coupon can then be removed from the pin. The buffer and test are to come from the same end of the pin as per Fig 7.

**Figure 7 : Buffer and test piece location**

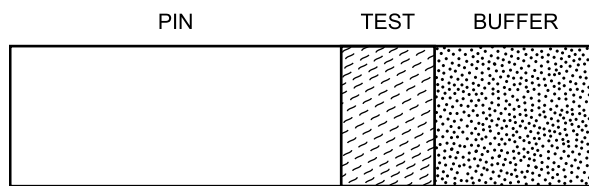

## **5.5 Non-destructive examination after proof load testing**

**5.5.1** All chain accessories are to be subjected to a close visual examination. Special attention is to be paid to machined surfaces and high stress regions. Prior to inspection, chain accessories are to have a suitably prepared surface as per the applied NDE testing standard. All non-machined surfaces are to be sand or shot blast to permit a thorough examination. Where applicable, accessories shall be dismantled for inspection of internal surfaces. All accessories are to be checked by magnetic particles or dye penetrant technique.

**5.5.2** Testing is to be performed in accordance with a recognized standard, such as those indicated below, or others recognized standards:

- a) magnetic particle testing (MT) of forgings:
  - EN 10228-1, ASTM A275, using wet continuous magnetization technique or equivalent standards such as ISO 4986, IACS Rec.69.
- b) ultrasonic testing (UT) of forgings:
  - EN 10228-3, ASTM A388, ISO 13588.
- c) magnetic particle testing (MT) of castings:
  - ASTM E709, using wet continuous magnetization technique.
- d) ultrasonic testing (UT) of castings:
  - ASTM A609, ISO 13588.

The procedures, together with acceptance criteria are to be submitted to the Society for review.

**5.5.3** Manufacturer shall prepare written procedures for NDE. NDE personnel shall be qualified and certified according to ISO 9712, ACCP or equivalent. Personnel qualification to an employer or responsible agency based qualification scheme as SNT-TC-1A may be accepted if the employer's written practice is reviewed and found acceptable and the Level III is ASNT Level III, ISO 9712 Level III or ACCP professional Level III and certified in the applicable method. NDE operators shall be qualified to at least level II.

**5.5.4** All surfaces shall be magnetic particle tested (MT). Testing shall be performed in accordance with standards referenced using the fluorescent technique. As a minimum surfaces shall be free from:

- relevant linear indications exceeding 1,6 mm in transverse direction
- relevant linear indications exceeding 3,2 mm in longitudinal direction
- relevant non-linear indications exceeding 4,8 mm.

When required by the Society, ultrasonic testing is to be carried on 100% of cast or forged accessories. The acceptance/rejection criteria established for the design is to be met.



**5.5.5** The manufacturer is to provide a statement that non destructive examination has been carried out with satisfactory results. This statement should include a brief reference to the techniques and to the operator's qualification.

**5.5.6** Weld repairs of finished accessories are not permitted.

## **5.6 Test failures**

**5.6.1** In the event of a failure of any test the entire batch represented is to be rejected unless the cause of failure has been determined and it can be demonstrated to the Surveyor's satisfaction that the condition causing the failure is not present in any of the remaining accessories.

## **5.7 Marking**

**5.7.1** Each accessory is to be marked as follows:

- Chain grade
- Society's marks.

**5.7.2** The certificate number may be exchanged against an abbreviation or equivalent. If so, this shall be stated in the certificate.

## **5.8 Documentation**

**5.8.1** A complete Inspection and Testing Report in booklet form shall be provided by the manufacturer for each order. This booklet shall include all dimensional checks, test and inspection reports, NDT reports, process records and example photographs of components positioned in furnaces, as well as any nonconformity, corrective action and repair work.

**5.8.2** Each type of accessory shall be covered by separate certificates.

**5.8.3** All accompanying documents, appendices and reports shall carry reference to the original certificate number.

**5.8.4** The manufacturer will be responsible for storing, in a safe and retrievable manner, all documentation produced for a period of at least 10 years.

# **6 Chafing chain for single point mooring arrangements**

## **6.1 Scope**

**6.1.1** These requirements apply to short lengths (approximately 8 m) of 76 mm diameter chain to be connected to hawsers for the tethering of oil carriers to single point moorings, FPSO's and similar uses.

## **6.2 Approval of manufacturing**

**6.2.1** The chafing chain is to be manufactured by works approved by the Society according to [1.3].

## **6.3 Materials**

**6.3.1** The materials used for the manufacture of the chafing chain are to satisfy the requirements of [2].

## **6.4 Design, manufacturing, testing and certification**

**6.4.1** The chafing chain is to be designed, manufactured, tested and certified in accordance with [3] [4] [5], except that batch heat treatment is permitted.

**6.4.2** The arrangement of the end connections is to be of an approved type.

**6.4.3** The common link is to be of the stud link type - grade QR3 or QR4.

**6.4.4** The chafing chain is to be capable of withstanding the breaking test loads of 4884 kN (grade QR3) and 6001 kN (grade QR4). See Note 1.

**6.4.5** The chain lengths shall be proof load tested in accordance with [4.2]. The test load is 3242 kN for grade QR3 and 4731 kN for grade QR4.

Note 1: Documented evidence of satisfactory testing of similar diameter mooring chain in the prior 6 month period may be used in lieu of break testing subject to agreement with the Society.

Note 2: The requirements herein are also applicable to other diameter chafing chains, such as 84 mm and 96 mm, subject to compliance with the proof and break load requirements specified for the chain grade and diameters in Tab 5.

# Section 5 Steel Wire Ropes

## 1 Requirements

### 1.1 Scope

**1.1.1** The requirements of this Section apply to unalloyed steel wire ropes, round stranded, intended for warping, towing, rigging and similar applications.

#### 1.1.2 Continuous production

In the case of continuous production, upon request of the manufacturer a specific procedure for testing and inspection may be approved by the Society.

### 1.2 Manufacturing

#### 1.2.1 General

Manufacturers of steel wire ropes and their individual works are to be recognised by the Society in accordance with NR320.

Wire ropes are to be manufactured in accordance with national or international standards recognised by the Society. In particular, ISO 2408 Standard is recognised.

The type and size of ropes are to be in accordance with the requirements specified for each application by the relevant part of the Rules or the approved plans relative to each installation.

Ropes of type and size different from those covered by this Section are considered in each case, taking into account their application.

#### 1.2.2 Rope materials

Ropes are to be manufactured with wires drawn from steel billets of appropriate and homogeneous quality; the steel is to be made by a process in accordance with Ch 3, Sec 1, [2].

Wires are not to show signs of defects and their surface is to be smooth and regular.

All the steel wires of a wire rope are to be of the same tensile grade, generally including those forming the metal core, if any.

As a rule, wires having the minimum nominal tensile strength  $R_m$  in the range 1420 - 1960 N/mm<sup>2</sup> are to be used.

The fibre core of the ropes or of the strands may be made of natural fibres (manilla, abaca, sisal, hemp, jute, cotton) or of synthetic fibres (polyethylene, polypropylene, polyamid, polyester).

#### 1.2.3 Galvanising

All types of wire ropes are to be zinc-coated, except in special cases to be considered individually by the Society and generally involving limitation in the use of the wire ropes concerned.

Galvanising procedures and their results (in particular, degree of bonding and uniformity of the coating) are to be suitable and to the satisfaction of the Society.

The wires are to be galvanised so that the zinc mass satisfies the values specified in Tab 1.

**Table 1 : Galvanising of the wires of wire ropes**

Diameter d of galvanised wires (mm)	Minimum mass of zinc coating (g/m <sup>2</sup> )	
	Class A	Class B
0,45 ≤ d < 0,50	75	40
0,50 ≤ d < 0,60	90	50
0,60 ≤ d < 0,80	110	60
0,80 ≤ d < 1,00	130	70
1,00 ≤ d < 1,20	150	80
1,20 ≤ d < 1,50	165	90
1,50 ≤ d < 1,90	180	100
1,90 ≤ d < 2,50	205	110
2,50 ≤ d < 3,20	230	125
3,20 ≤ d < 4,00	250	135



**Table 2 : Permissible tolerances on nominal diameter**

Nominal diameter of rope (mm)	Tolerance on the nominal diameter (%)	
	Ropes having strands with fibre core	Ropes having strands with metal core
< 8	+7; -1	+5; -1
≥ 8	+6; -1	+4; -1

**1.2.4 Quality of materials**

Ropes are to be free from material or manufacturing defects which might impair their intended application, their efficiency, or their expected life span; in particular, they are to be free from oxidising or corrosion traces and there is to be no sign of broken wires, scratching, crushing or defective twisting.

**1.2.5 Dimensional tolerances**

Unless otherwise specified, the tolerances on the diameter given in recognised standards such as ISO 2408 apply; in particular, for the ropes considered in these Rules, the tolerances on the diameter are specified in Tab 2.

**1.3 Types of ropes**

**1.3.1 General**

The wire ropes consist of an assembly of several strands (as a rule, at least six and a maximum of eight, except for non-rotating ropes) laid around a fibre or metal core.

Each strand is to include at least seven wires. In the case of a fibre core, the strands are to include at least two layers of wires.

The following types of ropes are the most commonly used:

- a) ropes with 6 equal strands around a fibre core; each strand may include either 7, 19 or 37 steel wires (total number of wires: 42, 114 or 222); see Tab 3
- b) ropes with 6 equal strands around a fibre core; each strand includes a fibre core and 24 steel wires (total number of wires: 144 plus 6 fibre cores); see Tab 4
- c) Warrington 6x19 ropes with 6 equal strands around a fibre core; each strand includes 19 steel wires (total number of wires: 114); see Tab 5
- d) Warrington-Seale 6xn ropes with 6 equal strands around a fibre core; each strand includes n = 26, 31, 36 or 41 steel wires: see Tab 5.

Other types of ropes which may be used depending on the applications are also indicated in Tab 3 to Tab 7.

**1.3.2 Main characteristics**

The typical characteristics of the ropes are generally the following:

- diameter (of the circumference enclosing a cross-section of the rope; to be measured with the rope strained under a load of approximately 1/20 of its minimum breaking strength)
- construction (number and type of the cores, strands and wires)
- coating or type of surface finish of the steel wires
- breaking load.

As regards the ropes considered by the Rules, the following applies to the above characteristics:

- the wire coating is to be of zinc in all cases
- the minimum breaking loads applicable when testing full sections of ropes are given in Tab 3 to Tab 7 for each type of rope in relation to its diameter.

**1.4 Sampling and testing**

**1.4.1 Sampling**

Acceptance tests are to be performed on each rope length (defined as either one single length or multiple lengths manufactured with continuity).

Where the rope length is greater than 10000 m, the acceptance tests are to be carried out for every portion of 10000 m or fraction thereof.

When the base material used has the same origin and characteristics, the acceptance tests required in [1.4] for each rope length may be performed for each rope construction and diameter.

Suitable sampling and identification procedures are to be adopted, to the Surveyor’s satisfaction.

The tests and examinations under [1.4.2], [1.4.3] or [1.4.4], [1.4.6] and [1.4.8] are to be performed for acceptance.

The tests under [1.4.5] and [1.4.7] are to be carried out when required by the Surveyor as a production check.

**1.4.2 Visual examination and check of the diameter and construction**

The examination and checks are to be performed by the Manufacturer and random checks are to be carried out by the Surveyor to the extent deemed necessary.

### 1.4.3 Breaking test on full size specimens

Samples and testing procedures are to be in compliance with recognised standards, such as ISO 3108.

The test sample is to be long enough to obtain a clear distance, between the grips of the testing machine, at least equal to 30 times the diameter of the ropes, with a minimum of 600 mm.

The above clear distance may be reduced to 300 mm if the diameter is less than 6 mm.

During the test, when the applied load has exceeded approximately 80% of the required breaking load, the load is to be applied slowly and steadily (about 10 N/mm<sup>2</sup> per second).

The breaking load is to be not less than the minimum value required in Tab 3 to Tab 7 for each type and diameter of rope.

The result of the test may be disregarded if the specimen breaks outside the gauge length, in particular in way of the terminals.

### 1.4.4 Breaking test on individual wires

As an alternative, when the breaking test on full size specimens cannot be performed, the breaking strength of the rope may be determined, in agreement with the Surveyor, as the sum of the actual breaking strengths determined on the individual wires, multiplied by the factor K (realisation factor) applicable in relation to the type and construction of the rope.

The factor K applicable to types of rope in current use is given in Tab 8 (for other types of ropes, the factor K is stated by the Society in each case).

The tensile test is to be performed on at least 10% of the wires of the rope to be tested, with a minimum of two wires per strand.

The wires tested are to satisfy the tensile requirements specified for the wires and the total breaking load of the n wires tested multiplied by the ratio N/n (where N is the total number of wires of the rope) and by the factor K (depending on the type of the rope) is to be not less than the minimum value specified by the recognised standard applied.

The acceptance of the check of the breaking load of the rope by means of tensile tests on individual wires is, in general, subject to a number of proof tests on samples of full size ropes which are representative of the production for comparison purposes.

### 1.4.5 Check of the strength of individual wires

This check, consisting of tensile tests on individual wires, is performed only when required by the Surveyor as a check on the base materials employed.

### 1.4.6 Torsion test and coiling test on individual wires

In general only one of these tests is to be performed.

The tests are to be carried out on specimens obtained after galvanising from at least 5% of the number of wires taken at random in several strands with a minimum of 6 wires and a maximum of 10 wires for each diameter.

- Torsion test

The gauge length of the wire specimens, measured between the end terminals, is to be 100 times the wire diameter, but need not exceed 300 mm for wire diameters above 3 mm.

The wire is to be well clamped at the ends and well strained, e.g., under an axial load not exceeding 2% of its nominal breaking load.

The wire is then subjected to torsion until fracture occurs; the torque is to be applied as uniformly as possible, at the approximate rate of 60 - 70 revolutions per minute. The minimum required number of twists without fracture is specified in Tab 9.

The torsion test is not required for wires of diameter lower than 0,5 mm.

- Coiling test

The test consists of coiling a specimen of wire of sufficient length 8 times, in closed coils, around a cylindrical mandrel having a diameter equal to that of the wire; the wire is to be subsequently uncoiled and straightened.

After having been coiled, the zinc coating is not to show any sign of significant cracks or laminations. In the subsequent uncoiling and straightening, fracture of the wire is not to occur.



### 1.4.7 Checks of the zinc mass

The mass of zinc coating per unit area is required to be checked in accordance with a recognised standard.

The results of this test are to demonstrate compliance with the minimum required values specified in Tab 10.

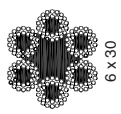
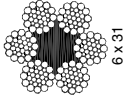
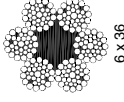
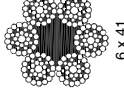
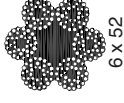

**Table 4 : Minimum breaking loads, in kN, of steel wire ropes with fibre core (non parallel lay ropes with 6 ordinary strands)**

Composition of wire rope	 6 x 61 1 + 6 + 12 + 18 + 24 Ordinary				 6 x 24 Fibre core + 9 + 15 Ordinary				 6 x 30 Fibre core + 12 + 18 Ordinary			
	Tensile grade				Tensile grade				Tensile grade			
	1420	1570	1770	1960	1420	1570	1770	1960	1420	1570	1770	1960
10				39,8	44,0	49,6	54,9	61,0	67,4	76,0	84,1	
11				48,1	53,2	60,0	66,4	70,7	78,2	88,1	97,6	
12				57,3	63,3	71,4	79,0	84,1	92,3	102	115	
13				67,2	74,3	83,8	92,7	99,3	108	117	127	
14				77,9	86,2	97,1	108	117	129	146	161	
16				102	113	127	140	144	160	180	199	
18				129	142	161	178	175	193	218	241	
20	165	182	205	227	229	253	285	208	230	259	287	
22	199	220	248	275	269	297	335	244	270	304	337	
24	237	262	296	327	312	345	389	283	313	352	390	
26	278	308	347	384	407	450	507	369	408	460	510	
28	323	357	402	446	515	570	642	467	517	583	645	
32	422	466	526	582	636	703	793	577	638	719	797	
36	534	590	665	737	770	851	959	698	772	870	964	
40	659	728	821	909	916	1013	1142	831	919	1036	1147	
44	797	881	994	1100	1075	1189	1340	975	1078	1216	1346	
48	949	1049	1183	1310	1247	1379	1554	1131	1251	1410	1561	
52	1114	1231	1388	1537	1431	1583	1784	1298	1436	1618	1792	
56	1291	1428	1610	1783	1629	1801	2030	1477	1633	1841	2039	
60	1482	1639	1848	2046				1668	1844	2079	2302	
64	1687	1865	2102	2328				1870	2067	2331	2581	
68	1904	2105	2373	2628				2083	2303	2597	2876	
72	2135	2360	2661	2947								
76	2379	2630	2965	3283								

**Note 1:** For wire ropes with metal core, the minimum breaking loads given in this table are to be increased by 8%.  
For preformed wire ropes, the values in the table are to be reduced by 3%.

Table 5 : Minimum breaking loads, in kN, of steel wire ropes with fibre core (Warrington and Warrington-Seale lay ropes with 6 strands)

Composition of wire rope	 6 x 19				 6 x 31				 6 x 36				 6 x 41				 6 x 52			
	1 + 6 + (6 + 6)				Composition of type 1 + n + (n + n) + 2n				Composition of type 1 + n + (n + n) + 2n				Composition of type 1 + n + (n + n) + 2n				1 + 6 + 9 + (9 + 9) + 18			
	Warrington				Warrington - Seale				Warrington - Seale				Warrington - Seale				Warrington - Seale			
Diameter of rope (mm)	Tensile grade				Tensile grade				Tensile grade				Tensile grade				Tensile grade			
	1420	1570	1770	1960	1420	1570	1770	1960	1420	1570	1770	1960	1420	1570	1770	1970	1420	1570	1770	1970
10					46,9	51,8	58,4	64,7												
11					56,7	62,7	70,7	78,3												
12	67,7	74,8	84,4	93,4	67,5	74,6	84,1	93,1												
13	79,4	87,8	99,0	110	79,2	87,6	98,7	109												
14	92,1	102	115	127	91,8	102	114	127												
16	120	133	150	166	120	133	150	166												
18	152	168	190	210	152	168	189	210												
20	188	208	234	260	187	207	234	259												
22	227	252	284	314	227	251	283	313												
24	271	299	337	374	270	298	336	373												
26	318	351	396	439	317	350	395	437												
28	368	407	459	509	367	406	458	507												
32	481	532	600	664	480	531	598	662												
36	609	673	759	841	607	671	757	838												
40	752	831	937	1038	750	829	935	1035												
44	910	1006	1134	1256	907	1003	1131	1252												
48	1083	1197	1350	1495	1080	1194	1346	1490												
52					1267	1401	1579	1749												
56					1470	1625	1832	2028												
60					1687	1865	2103	2328												
64					1919	2122	2392	2649												
68																				
72																				
76																				

**Note 1:** For wire ropes with metal core, the minimum breaking loads given in this table are to be increased by 8%. For preformed wire ropes, the values in the table are to be reduced by 3%.

**Table 6 : Minimum breaking loads, in kN, of steel wire ropes with fibre core (Seale lay ropes with 6 strands)**

Composition of wire rope	6 x 19 F (*)		6 x 19		6 x 25		6 x 37	
	1 + 9 + 9		1 + (6 + 6 F) + 12		1 + 6 + 9 + 9		1 + 6 + 15 + 15	
	Seale (1)							
Diameter of rope (mm)	Tensile grade		Tensile grade		Tensile grade		Tensile grade	
	1420	1570	1770	1960	1420	1570	1770	1960
10	47,0	52,0	58,6	64,9	148	164	185	204
11	56,9	62,9	70,9	78,5	183	202	228	252
12	67,7	74,8	84,4	93,4	221	245	276	305
13	79,4	87,8	99,0	110	263	291	328	364
14	92,1	102	115	127	309	342	385	427
16	120	133	150	166	358	396	447	495
18	152	168	190	210	468	518	584	646
20	188	208	234	260	593	655	739	818
22	227	252	284	314	732	809	912	1010
24	271	299	337	374	885	979	1103	1222
26	318	351	396	439	1053	1165	1313	1454
28	368	407	459	509	1236	1367	1541	1707
32	481	532	600	664				
36	609	673	759	841				
40	752	831	937	1038				
44								
48								
52								
56								
60								
64								
68								
72								
76								

**Note 1:** For wire ropes with metal core, the minimum breaking loads given in this table are to be increased by 8%.

For preformed wire ropes, the values in the table are to be reduced by 3%.

(1) Minimum breaking loads as indicated correspond to 6 x 19 Seale lay ropes.

For 6 x 19 F Seale Filler lay ropes, sometimes called 6 x 25 Filler, the given values are to be increased by 2%.

**Table 7 : Minimum breaking loads, in kN, of steel wire ropes with fibre core (ropes with 8 strands and non-rotating ropes)**

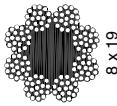
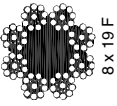
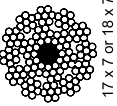
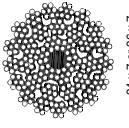
Composition of wire rope	 8 x 19		 8 x 19 F		 17 x 7 or 18 x 7		 34 x 7 or 36 x 7	
	1 + 9 + 9		1 + (6 + 6 F) + 12		1 + 6		1 + 6	
	Seale (1)		Seale (1)		Ordinary		Ordinary	
Diameter of rope (mm)	1420	1570	1770	1960	1420	1570	1770	1960
10	41,6	46,0	51,9	57,4	46,6	51,5	58,1	64,3
11	50,3	55,7	62,8	69,5	56,4	62,3	70,2	77,8
12	59,9	66,2	74,7	82,7	67,1	74,2	83,6	92,6
13	70,3	77,7	87,6	97,1	78,7	87,0	98,1	109
14	81,5	90,2	102	113	91,3	101	114	126
16	107	118	133	147	119	132	149	165
18	135	149	168	186	151	167	188	208
20	166	184	207	230	186	206	232	257
22	201	223	251	278	225	249	281	311
24	240	265	299	331	268	297	334	370
26	281	311	351	388	315	348	392	435
28	326	361	407	450	365	404	455	504
32	426	471	531	588	447	527	594	658
36	539	596	672	744	604	667	752	833
40					745	824	929	1029
44					902	997	1124	1245
48					1073	1186	1338	1481
52					1259	1392	1570	1738
56								
60								
64								
68								
72								
76								

**Note 1:** For wire ropes with metal core, the minimum breaking loads given in this table are to be increased by 8%.

For preformed wire ropes, the values in the table are to be reduced by 3%.

(1) Minimum breaking loads as indicated correspond to 8 x 19 Seale lay ropes.

For 8 x 19 F Seale Filler lay ropes, sometimes called 8 x 25 Filler, the given values are to be increased by 2%.

Table 8 : Realisation factor K

Construction of rope (1)	Construction of strands (2)	Type of rope stranding (3)	Realisation factor K (4)	
			Fibre core (5)	Metal core (6)
6 x 7	1 + 6	O	0,90	0,870
6 x 19	1 + 6 + 12	O	0,87	0,835
6 x 19	1 + 9 + 9	S	0,87	0,835
6 x 19 F (7)	1 + (6 + 6 F) + 12	S - F	0,87	0,835
6 x 19	1 + 6 + (6 + 6)	W	0,87	0,835
6 x 24	fibre core + 9 + 15	O	0,87	-
6 x 25	1 + 6 + 9 + 9	S	0,86	0,825
6 x 26	1 + 5 + (5 + 5) + 10	W - S	0,85	0,815
6 x 30	fibre core + 12 + 18	O	0,87	-
6 x 31	1 + 6 + (6 + 6) + 12	W - S	0,85	0,815
6 x 36	1 + 7 + (7 + 7) + 14	W - S	0,85	0,815
6 x 37	1 + 6 + 12 + 18	O	0,85	0,815
6 x 37	1 + 6 + 15 + 15	S	0,85	0,815
6 x 41	1 + 8 + (8 + 8) + 16	W - S	0,85	0,815
6 x 52	1 + 6 + 9 + (9 + 9) + 18	W - S	0,81	0,775
6 x 61	1 + 6 + 12 + 18 + 24	O	0,81	0,775
8 x 19	1 + 9 + 9	S	0,83	-
8 x 19 F (7)	1 + (6 + 6 F) + 12	S - F	0,83	-
17 x 7	1 + 6	O	0,84	0,815
18 x 7	1 + 6	O	0,84	0,815
34 x 7	1 + 6	O	0,80	0,790
36 x 7	1 + 6	O	0,80	0,790

- (1) The first figure gives the number of strands, the second the number of wires in each strand.
- (2) The figures give the number of wires for each layer; the figures in brackets are relevant to wires of the same layer but of two different diameters. The letter F indicates filler wires.
- (3) The type of rope stranding indications are as follows:
- O: ordinary strands (non-parallel wires);
  - S, S-F, W and W-S (strands with parallel wires): designate Seale, Seale-Filler, Warrington and Warrington-Seale strandings, respectively.
- (4) The coefficient K is to be reduced by 3% for preformed ropes.
- (5) The fibre core is not considered in the breaking load of the rope.
- (6) The metal core consists of an independent rope (in general 6x7 with centre strand of 7 wires); it may, however, consist of a single strand for wire ropes of 6x7 and 6x19 wires with ordinary strands.
- (7) 6x19 and 8x19 Filler wire ropes are sometimes designated by 6x25 Filler and 8x25 Filler, respectively.

Table 9 : Torsion test for wires - Minimum number of twists

Diameter d (mm)	Galvanising class A			Galvanising class B			
	Tensile grade			Tensile grade			
	1420	1560	1770	1420	1560	1770	1960
d < 1,3	19	18	17	31	29	26	18
1,3 ≤ d < 1,8	18	17	16	30	28	25	17
1,8 ≤ d < 2,3	18	17	16	28	26	25	16
2,3 ≤ d < 3,0	16	14	12	26	24	22	15
3,0 ≤ d < 3,5	14	12	10	24	22	20	13
3,5 ≤ d < 3,7	12	10	8	20	20	18	12



**Table 10 : Check of zinc continuity on wire coating**

Diameter d of galvanised wire (mm)	Number of one-minute submersions (1)	
	Class A	Class B
$0,6 \leq d < 1,0$	–	0,5
$1,0 \leq d < 1,5$	1,5	1,0
$1,5 \leq d < 1,9$	2,0	1,0
$1,9 \leq d < 2,5$	2,0	1,5
$2,5 \leq d < 3,2$	2,5	1,5
$3,2 \leq d < 3,7$	3,0	2,0

(1) 1,5 submersion means one submersion lasting 1 minute followed by another lasting 30 seconds (the same criteria applies for the other numbers).

**1.4.8 Check of the uniformity and continuity of the zinc coating**

This test is performed when required by the Surveyor as a production check. It applies only to wires of diameter  $\geq 1$  mm if galvanised of class A and of diameter  $\geq 0,6$  mm if galvanised of class B.

The tests are to be carried out on specimens obtained after galvanising from at least 5% of the number of wires taken at random in several strands with a minimum of 6 wires and a maximum of 10 wires for each diameter.

Unless otherwise specified, the test is performed by submerging a specimen in a water solution of pure crystalline copper sulphate ( $\text{Cu SO}_4 \cdot 5 \text{ H}_2\text{O}$ ) containing at least 360g of salt per litre of distilled water at a temperature of  $20^\circ\text{C} \pm 2^\circ\text{C}$ .

The specimen is to be immersed for a length of at least 80 mm and is to be maintained in vertical position.

Tab 10 shows the minimum number of one-minute submersions, in relation to the wire diameter and galvanising class. After each submersion, the specimen is to be rinsed in running water so as to wash away unbonded copper deposits.

The test is regarded as satisfactory when the specimen does not show (beyond 25 mm from the immersed end) indications of bonded copper deposits, which would mean local lack of zinc coating on the steel surface.

**1.5 Identification marking and certification**

**1.5.1** Upon satisfactory completion of the required tests and examinations, the ropes, packed in the required length for supply, are to be tagged with lead seals stamped with the Society’s brand and further indications, as necessary for identification with the respective test certificates.

**1.5.2** The certificates are to contain the essential elements relevant to the rope characteristics, the results of the test and the stamps and markings mentioned in [1.5.1].

Special marking and certification methods may be agreed upon for supplies by Manufacturers granted the use of an alternative testing procedure.

# Section 6 Fibre Ropes

## 1 Requirements

### 1.1 Scope

#### 1.1.1 General

The requirements of this Section apply to fibre ropes, intended for towing and mooring lines, emergency towing arrangement, cargo handling gear or similar applications, other than those specified in [1.1.2] [1.1.3].

#### 1.1.2 Single Point Mooring Hawsers

Hawsers intended for mooring oil tankers (single point mooring) at an offloading buoy are to be made of fibres of an approved type, as per annex 4 in NI 432, and are to be inspected and tested in accordance with the OCIMF “Guidelines for the purchasing and testing of single point mooring hawsers”, 2000, under survey by the Society.

#### 1.1.3 Fibre ropes for deep water offshore services

Requirements for the certification of fibre ropes intended for use as load-bearing components in the stationkeeping system of a floating offshore unit, or for other offshore deepwater applications, are defined in Guidance Note NI 432 Certification of Fibre Ropes for Deepwater Offshore Services.

### 1.2 Design

1.2.1 Ropes, rope material, rope construction and size are to be in accordance with the ISO standards specified below, or another consistent set of recognised standards accepted by the Society:

- ISO 9554: Fibre ropes - General specifications
- the ISO product standard proposed by the manufacturer for the concerned material and construction.

Ropes are to be of the size (reference number, or “nominal diameter” or circumference) needed to meet the specified breaking strength, or other relevant requirement of the Rules.

### 1.3 Sampling and testing

#### 1.3.1 General

The following examinations and tests, as defined in [1.3.3] to [1.3.5], are to be performed in accordance with the relevant provisions of ISO 2307: “Fibre ropes - Determination of certain physical and mechanical properties”:

- linear density
- breaking strength on a full size sample, or determination of rope strength from yarn testing, when applicable.

The required tests and examinations are to be performed with the appropriate machinery, equipment and procedures.

The machines for load testing and weighing are to be calibrated.

#### 1.3.2 Sampling

Acceptance tests are to be performed on each length manufactured in continuous production, but not less than once every 2000m.

#### 1.3.3 Linear density

The linear density of the rope under the reference tension, measured following the procedure and requirements in ISO 2307, is to be in accordance with the value for the specified rope size in the applicable product standard.

#### 1.3.4 Breaking test on full size specimen

The breaking strength of the rope is to be verified by testing to destruction a sample of rope, following the procedure and requirements in ISO 2307.

The achieved breaking load is to be recorded, and is to be not less than that given in the applicable product standard for the specified size, taking into account acceptance criteria in ISO 2307.

### 1.3.5 Breaking test on individual yarns

When the breaking test on full size test pieces cannot be performed, and subject to agreement by the Society, the breaking strength is to be obtained by calculation based on breaking strength tests on yarns, according to the procedure given in Annex B of ISO 2307.

This is applicable only to ropes having a breaking strength above 250 kN, made from a single fibre material and size, and for those materials and construction where a realisation factor is given in the standard.

The relevant testing documentation is to include a mention stating that the breaking strength has been calculated.

## 1.4 Marking

**1.4.1** Upon satisfactory completion of the required tests and examinations, the packed ropes are to be tagged with the Society's stamp and identification of the inspection certificate issued by the Society.

## CHAPTER 11

# TYPE APPROVAL OF WELDING CONSUMABLES

---

- |            |   |
|------------|---|
| Section 1  | General Requirements  |
| Section 2  | Covered Electrodes for Manual Metal Arc Welding of C and C-Mn Steels                          |
| Section 3  | Covered Electrodes for Gravity or Contact Welding   |
| Section 4  | Covered Electrodes for Deep Penetration Manual Welding of C and C-Mn Steels                   |
| Section 5  | Flux-Wire Combination for Submerged Arc Welding of C and C-Mn Steels                          |
| Section 6  | Flux-Wire Combinations for One Side Submerged Arc Welding of Butt-Joints of C and C-Mn Steels |
| Section 7  | Wires and Wire-Gas Combination for Semiautomatic Welding of C and C-Mn Steels                 |
| Section 8  | Wires and Wire-Gas Combinations for Automatic Welding of C and C-Mn Steels                    |
| Section 9  | Consumables for Welding C and C-Mn Steels with Electrode Gas or Electroslag Process           |
| Section 10 | Consumables for Welding Extra High Strength Steels  |
| Section 11 | Consumables for Welding EH47 Steel and Crack Arrest Steel EH47CAS                             |
| Section 12 | Consumables for Welding Mo and Cr-Mo Steels   |
| Section 13 | Consumables for Welding Ni Steels for Low Temperature Applications                            |
| Section 14 | Consumables for Welding Cr-Ni Austenitic and Austenitic-Ferritic Stainless Steels             |
| Section 15 | Consumables for Welding Aluminium Alloys  |

# Section 1 General Requirements

## 1 Scope

### 1.1 General

**1.1.1** The requirements of this Chapter apply to the approval and periodical control tests of consumables for welding carbon and carbon manganese steels, high strength quenched and tempered steels, chromium and chromium-molybdenum steels, nickel steels for low temperature applications, austenitic and austenitic-ferritic stainless steels, and aluminium alloys.

This Section specifies the requirements common to all the above-mentioned welding consumables, while the appropriate specific requirements are indicated in Sec 2 to Sec 15.

The following categories of welding consumables are considered:

- covered electrodes for manual and gravity welding
- wire/flux combinations for submerged arc welding
- solid wire/gas combinations for continuous wire arc welding
- flux cored wires for continuous wire arc welding with or without shielding gas
- consumables for electrogas and electroslag welding.

## 2 Grading and designation

### 2.1 General

**2.1.1** Consumables are classified depending on the mechanical and chemical properties of the filler metal; different grades or type of consumables may be considered for specific applications or materials on a case-by-case basis.

### 2.2 Consumables for C and C-Mn steels and for Q-T steels

**2.2.1** Welding consumables intended for welding C and C-Mn steels are divided into groups related to the strength level (minimum specified yield strength) of the steel; each group is subdivided into grades depending on the impact test temperatures, as indicated in Tab 1.

### 2.3 Consumables for Mo and Cr-Mo steels

**2.3.1** Consumables intended for welding Mo and Cr-Mo steels are designated by a symbol indicating the nominal Mo and Cr percentage content of the deposited weld metal, as follows:

- M for Mo = 0,5
- C1M for Cr = 1,25 and Mo = 0,5
- C2M1 for Cr = 2,25 and Mo = 1

**Table 1 : Consumable grades for C-Mn steels**

Steel strength level	Consumable grades based on impact test temperature at (°C)				
	+ 20	0	- 20	- 40	- 60
Normal strength	1	2	3	4	-
Higher strength (1) • $\geq 315, < 360$ N/mm <sup>2</sup> • $\geq 360, < 400$ N/mm <sup>2</sup>	1Y (2)	2Y 2Y40	3Y 3Y40	4Y 4Y40	5Y 5Y40
Extra high strength (1)			3Y42, 3Y46, 3Y50, 3Y55, 3Y62, 3Y69, 3Y89, 3Y96	4Y42, 4Y46, 4Y50, 4Y55, 4Y62, 4Y69, 4Y89, 4Y96	5Y42, 5Y46, 5Y50, 5Y55, 5Y62, 5Y69
(1) The symbol Y, which indicates the high strength groups is followed, for steels having the minimum specified yield strength equal to, or higher than, 355 N/mm <sup>2</sup> , by a number related to the minimum specified yield strength value of the weld metal (e.g. 42 for a minimum yield strength of 420 N/mm <sup>2</sup> ).					
(2) Grade not applicable to covered electrodes.					

## 2.4 Consumables for Ni steels for low temperature applications

**2.4.1** Consumables intended for welding nickel steels are designated by a symbol indicating the type of nickel steel for which the consumables are intended, as follows:

- a) N15 for steels with Ni = 1,30 - 1,70(%)
- b) N35 for steels with Ni = 3,25 - 3,75 (%)
- c) N50 for steels with Ni = 4,75 - 5,25 (%)
- d) N90 for steels with Ni = 8,50 - 10,0 (%)

## 2.5 Consumables for austenitic and austenitic-ferritic (duplex) stainless steels

**2.5.1** Consumables intended for welding austenitic steels are designated by a symbol corresponding to the AWS designation of the weld deposit, as follows: 308, 308L, 316, 316L, 316LN, 317, 317L, 309L, 309, 309Mo, 310, 310Mo, 347.

Consumables intended for welding austenitic-ferritic steels are designated by a symbol indicating the nominal percentage content of Cr and Ni in the deposited metal (e.g. 2205 means 22% Cr and 5% Ni).

## 2.6 Consumables for aluminium alloys

**2.6.1** Consumables intended for welding aluminium alloys are designated by the initial letter R or W for rod or wire products, respectively, and by the letters A, B, C, D depending on the alloy type and strength level used for the approval tests.

## 2.7 Additional symbols

**2.7.1** Further symbols may be added, as appropriate, as a prefix or suffix to the grade as indicated in the following:

- a) prefix S or SA for semiautomatic welding process
- b) prefix A for automatic welding process
- c) prefix AV for electrogas or electroslag welding process
- d) suffix T, M, TM, U for automatic process with two run (T), multi-run (M), both (TM) or one-side (U) welding techniques
- e) suffix H or H15, HH or H10, HHH or H5 for controlled hydrogen content of weld metal as per Sec 2, Tab 5
- f) suffix D when mechanical properties on weld metal have also been verified in the stress relieved condition.

# 3 Approval procedure

## 3.1 Request for approval

**3.1.1** The request for approval is to be submitted to the Society by the Manufacturer, together with the specific information indicated in the Sections relevant to the various consumables.

## 3.2 Quality of manufacturing

**3.2.1** The Manufacturer's plant, method of production and quality control of welding consumables are to be such as to ensure reasonable uniformity in manufacture.

The Manufacturer is to ascertain this uniformity by means of analysis and systematic testing on each production batch.

In general, the consumables are to maintain the specified characteristics for a period of time of at least six months after the date of delivery, when properly stored in a dry atmosphere and kept in the original packaging.

The consumables are to be supplied so packaged as to ensure compliance with the above requirement; the packaging is to be sufficiently strong to resist the usual transportation and handling operations.

The Manufacturer is to stamp on each container or bag, as applicable, the markings which are necessary to trace back each production.

## 3.3 Approval tests

**3.3.1** The welding consumables are approved subject to a satisfactory inspection of the Manufacturer's works by the Surveyor and to satisfactory results of approval tests.

The approval tests required are to be performed on samples of consumables representative of the production.

Sampling procedures are to be agreed with the Surveyor.

In general, the approval tests consist of the following checks:

- a) check of the mechanical properties of the deposited metal and welded joints and of the chemical composition of the deposited metal
- b) check of the hydrogen contents, where required
- c) check, at the request of the interested parties, of freedom from hot cracks, under specific test conditions.

Welding and inspection of the test samples and mechanical tests are to be carried out in the presence of the Surveyor.

The tests are to be carried out in laboratories and test rooms recognised by the Society.

Unless otherwise specified, test specimens and procedures are to be in accordance with the applicable Society requirements or standards recognised by the Society.

### **3.4 Certification**

**3.4.1** Upon satisfactory completion of the approval tests, a certificate of approval, stating the grade under which the consumable has been approved and the terms of validity of the approval, is issued by the Society to the Manufacturer.

The approved welding consumables and relevant grades are entered in the special lists of consumables approved by the Society.

### **3.5 Annual inspections and tests**

**3.5.1** The workshops where approved materials are manufactured are subject to annual inspections by the Surveyor.

During the inspection, samples of the approved consumables are selected by the Surveyor and subjected to the tests detailed in the Sections relevant to the various products. These tests are to be repeated annually so as to provide an average of at least one test per year.

At the Society's discretion, the consumables to be used in the above tests may be obtained, instead of from the Manufacturer as stated above, from users or dealers; the consumables are to be recently produced (in general less than 6 months).

Alternative procedures based on quality control and quality assurance systems may be considered and accepted subject to special approval by the Society, which will state the relevant acceptance conditions on a case-by-case basis.

### **3.6 Manufacturer's responsibilities**

**3.6.1** After the approval has been obtained, and irrespective of the periodical tests carried out by the Society, the Manufacturer is fully responsible for the quality of the finished product and compliance with the specified requirements, as verified in the approval and periodical control tests.

The Manufacturer is to keep up-to-date records of the manufacture of the approved consumables, including details of the history of the single productions and results of associated tests. The Society is to have free access to these records at all times.

The Manufacturer is responsible for reporting to the Society any major modifications introduced in the production procedure subsequent to its approval.

Full compliance on the part of the Manufacturer with all the requirements stated by the Society in connection with the approval of consumables is an essential condition for granting and renewing such approval.

### **3.7 Firms with several workshops or dealers**

**3.7.1** When consumables of the same brand are manufactured in different workshops belonging to the same Manufacturer, the complete series of tests is generally performed in one workshop only. In the other workshops, a reduced test program, at least equivalent to annual tests, is permitted if the Manufacturer certifies that the material used and the fabrication process are identical to those used in the main works.

### **3.8 Different brand names**

**3.8.1** When a consumable already approved at a manufacturer is transferred for sale under a different brand name to the manufacturer or to a dealer, the manufacturer and the dealer where applicable have to certify that the consumable with the alternative brand name is strictly identical to the consumable already approved.

### **3.9 Changes in grading**

**3.9.1** Changes in grading of welding consumables are to be considered only at the Manufacturer's request, in general at the time of annual testing. For upgrading, tests from butt weld assemblies are generally required as a minimum in addition to normal annual tests, as specified here below.

For upgrading referring to impact properties, Charpy V-notch impact tests are to be performed at the upgrade temperature on the respective butt weld assemblies required for approval.

For upgrading referring to higher strength steels, all butt weld tests required for the approval are to be effected using higher strength steel as parent metal.

For upgrading referring to hydrogen content, tests according to Sec 2, [1.4] are to be carried out as appropriate.

Downgrading or withdrawal of the approval occurs when the prescribed tests and re-tests fail to meet the requirements.

### **3.10 Additional tests**

**3.10.1** The Society may, in some specific cases, request additional tests or requirements as deemed necessary.

## **4 Preparation and welding of test assemblies**

### **4.1 Base material**

**4.1.1** The base material used for the test assemblies is to be of the steel grade appropriate to the consumable grade as specified in the various Sections.

For the preparation of all weld metal test assemblies, any grade of structural steel may be used. When the chemical composition of welded metal is substantially different from the base material, an overlay of side walls and backing strip may be carried out, as deemed necessary.

For the preparation of butt welded assemblies, steel grades are to be chosen depending on the grade of consumables.

When a welded joint is performed, the edges of the plates are to be bevelled either by mechanical machining or by oxygen cutting; in the latter case, a descaling of the bevelled edges is necessary.

### **4.2 Welding conditions and type of current**

**4.2.1** Welding conditions used, such as amperage, voltage, travel speed etc., are to be within the range recommended by the Manufacturer for normal good welding practice.

Where it is stated that a filler metal is suitable for both alternating current (a.c.) and direct current (d.c.), alternating current is to be used for welding the test assemblies for mechanical tests. When samples for checking the operating characteristics are required, both types of current are generally to be used. When samples for hot cracking tests are required, direct current is to be used.

Direct current is identified in the approval documentation with the symbols:

- CC+ or DCEP for positive electrode
- CC- or DCEN for negative electrode.

### **4.3 Post-weld heat treatment**

**4.3.1** Post-weld heat treatment of the welded assemblies is not allowed where the consumables are to be approved for the as welded condition only.

## **5 Mechanical tests**

### **5.1 General**

**5.1.1** The test specimens for mechanical tests are to be taken from the welded assemblies as indicated in the various Sections; specimen preparation and test results are to comply with the requirements from [5.2.1] to [5.6.1].

The requirements relevant to the calibration of the equipment, preparation of test specimens and testing procedure, detailed in Chapter 2, are also to be complied with, as appropriate.

### **5.2 Tensile tests**

**5.2.1** Round test specimens for longitudinal tensile tests and flat test specimens for transverse tensile tests are to be taken as described below:

a) round specimen:

The longitudinal axis is to coincide with the centre of the weld and mid-thickness of the weld in the all weld metal assemblies and second run in the two run welded assemblies. The specimen is to be in accordance with Ch 2, Sec 2, [1.1.10]; the specimen may be heated to a temperature not exceeding 250°C for a period not exceeding 16 hours, for hydrogen removal prior to testing.

The yield stress, tensile strength and elongation are to be determined and are to comply with the requirements specified for the various consumables; the reduction of area is to be determined and reported for information.

b) flat tensile specimen:

The test specimen is to be in accordance with Ch 2, Sec 2, [1.1.11].

The tensile strength is to be determined together with the fracture position and is to comply with the requirements specified for the various consumables.

### **5.3 Transverse bend tests**

**5.3.1** Face and root bend test specimens having 30 mm width and full plate thickness are to be machined transverse to the welded joint. The upper and lower surfaces of the weld are to be filed, ground or machined flush with the surface of the plate and the corners in tension rounded to a radius not exceeding 2 mm.

Two bend specimens are required; one specimen is to be tested with the face of the weld in tension and the other with the root of the weld in tension.

If the plate thickness exceeds 25 mm, it may be reduced to this size by machining on the compression side of the test specimen.



Alternatively, two side bend specimens may be taken in lieu of root and face bend specimens; side bend specimens may also be required in addition to or in lieu of root and face bend specimens for specific applications [5.4.1].

Bend test specimens are to be bent without fracture or cracks through an angle of 120°, unless a different angle is specified over a former having diameter as indicated in the various Sections; however superficial cracks or open defects not exceeding 3 mm may be disregarded.

**5.4 Side bend tests**

**5.4.1** Side bend test specimens, with thickness equal to width and thickness at least 10mm, are generally required in addition to the root and face bend tests for the approval of wire/gas combinations, and are required in lieu of the root and face bend tests for electrogas or electroslag assemblies.

**5.5 Longitudinal bend tests**

**5.5.1** When longitudinal face or root bend tests are required, test specimens in accordance with an appropriate standard are accepted.

**5.6 Impact tests**

**5.6.1** Charpy V-notch impact specimens are to be cut with their longitudinal axis transverse to the weld joint and positioned as follows:

- a) for deposited metal and butt weld test assemblies with multi-run technique: at mid-thickness of the weld
- b) for two run welded test assemblies: on the second run side, 2mm below the surface
- c) for electroslag and electrogas welded test assemblies: 2 mm below the surface
- d) for one side automatic welding processes: 2 mm below the face side and 2 mm below the root side of the test assemblies; for thicknesses ≥ 30 mm, specimens at mid-thickness are also to be taken.

The notch is to be cut in the face of the specimen perpendicular to the surface of the plate and to be positioned in the centre of the weld. For electrogas and electroslag welding, an additional set with the notch at 2 mm from the fusion line in the weld metal is to be taken.

A set of three specimens is to be prepared and tested. The average impact energy is to comply with the values specified for the various consumables and only one individual value may be lower than the average required, provided it is not lower than 70% of it.

**6 Test samples for checking the chemical composition of deposited weld metal**

**6.1 General requirements**

**6.1.1** For some products (see Sec 12, Sec 13, Sec 14), the chemical composition of weld metal deposited with electrodes is required to be verified on samples welded for this purpose.

**6.1.2** The test samples consist of a test plate of the specified steel having minimum sides 80 x 80 mm<sup>2</sup> and 15 mm thickness. On the above test plate, whose surface is to be cleaned by grinding to remove any trace of oxide, grease and paint, a weld pad is deposited in layers by welding in the flat position, each layer being formed by flanked beads. The minimum dimensions of the pad are to be as indicated in Tab 2.

The width of each bead of each layer is to be 1,5 to 2,5 times the diameter of the electrode. It is recommended that each layer should be deposited in a direction perpendicular to the previous one.

The current adopted for welding the test samples is to be within the range recommended by the Manufacturer; in the case of electrodes for use both with a.c. and d.c. current, the welding is to be carried out with alternating current.

After each layer has been deposited, the pad may be cooled to room temperature by immersion in water for 30 seconds.

The surface of each layer is to be free from slag inclusions and blow holes.

**6.1.3** After the welding is completed, the top surface of the pad is to be removed by mechanical means and discarded. Shavings sufficient for checking the chemical composition are then to be taken in such a manner that no metal is removed closer to the surface of the base plate than the distance indicated in Tab 3.

The use of lubricating oils during the mechanical machining for taking out the shavings is to be avoided.

**Table 2 : Pad dimensions**

Diameter of tested electrode, in mm	Minimum length and width of the pad, in mm	Minimum thickness of the pad, in mm
2,5	30 x 30	13
3,25 - max.	40 x 40	16

**Table 3 : Sampling method**

Diameter of tested electrode, in mm	Minimum distance from the base plate for taking out the shavings, in mm
2,5	6
3,25 - max.	8

## 7 Re-test procedures

### 7.1 General

**7.1.1** When for one or more test samples the execution of the weld, the external examination, the radiographic examination or the fracture produce results which are not considered satisfactory in some respects, and when the respective causes may be traced back to the operator or operating conditions, the test samples may be allowed to be repeated, in duplicate if deemed necessary, with the same procedure. In other cases, as well as when cracks are detected, the consumable will not be approved. The operating conditions for the re-test samples are to be agreed with the Surveyor, as deemed appropriate.

For the approval of the consumable, or for the continuation of the testing program, the re-test samples are to produce satisfactory results.

### 7.2 Tensile and bend tests

**7.2.1** Where the result of a tensile or bend test does not comply with the requirements, duplicate test specimens of the same type are to be prepared from the same sample and satisfactorily tested. Where insufficient original welded assembly is available, a new assembly is to be prepared using welding consumables of the same batch. If the new assembly is made with the same procedure (in particular the same number of runs) as the original assembly, only the duplicate re-test specimens need to be prepared and tested. Otherwise, all test specimens are to be prepared for re-testing.

### 7.3 Charpy V-notch impact test

**7.3.1** Reference is made to Ch 2, Sec 4, [1.4].

# Section 2 Covered Electrodes for Manual Metal Arc Welding of C and C-Mn Steels

## 1 Requirements

### 1.1 Scope

**1.1.1** The requirements of this Section apply to covered electrodes for manual metal arc welding of hull structural steels, of the corresponding grades of steel forgings and castings and of comparable steels intended for other structural applications or pressure systems.

#### 1.1.2 Designation

Electrodes are divided, for the various strength levels, into the following grades as defined in Sec 1, [2.2.1]:

- a) 1, 2, 3, 4 for normal strength grades
- b) 2Y, 3Y, 4Y, 5Y for high strength grades with specified minimum yield strength up to 355 N/mm<sup>2</sup>
- c) 2Y40, 3Y40, 4Y40, 5Y40 for high strength grades with specified minimum yield strength up to 390 N/mm<sup>2</sup>.

Depending on the hydrogen content of the weld metal, the symbol H15 or H, H10 or HH, H5 or HHH is added to the grade mark as in Sec 1, [2.7.1].

The symbols H15, H10, H5 indicate the hydrogen content determined with the mercury method and thermal conductivity detector method.

#### 1.1.3 Information and documentation to be submitted

The following information and supporting documentation, as appropriate, are generally to be submitted together with the request for approval:

- a) trade name of the electrode
- b) type of covering
- c) grades for which the application is made, including additional symbols
- d) typical chemical composition of the deposited metal
- e) type of current and welding positions
- f) proposed range of application and operating characteristics
- g) previous approvals granted to the electrodes with the necessary references.

## 1.2 Approval tests

### 1.2.1 General

The approval tests specified in Sec 1, [3.3.1] are to be performed as indicated in [1.3] to [1.6] and summarised in Tab 1.

## 1.3 Tests for checking the mechanical properties

### 1.3.1 General

The following tests indicated in Tab 1 are to be performed.

#### 1.3.2 Deposited metal test assemblies

Two deposited metal test assemblies are to be welded in the flat position as shown in Fig 1, one with 4 mm diameter electrodes and the other with the largest size manufactured. If an electrode is available in one diameter only, one test assembly is sufficient. Any grade of ship structural steel may be used for the preparation of the test assembly.

The weld metal is to be deposited in a single or multi-run layers according to normal practice, and the direction of deposition of each layer is generally to alternate from each end of the plate, each run of weld metal being not less than 2 mm and not more than 4 mm thick. Between each run the assembly is to be left in still air until it has cooled to less than 250°C but not below 100°C, the temperature being taken in the centre of the weld on the surface of the seam. After being welded, the test assemblies are not to be subjected to any heat treatment, except where approval has been requested also in the stress relieved condition [1.3.5]. In such case the symbol D is to be added to the grade designation.

The specimens shown in Fig 1 are to be taken for the following tests:

- a) one longitudinal tensile test
- b) three Charpy V-notch impact tests.

The results of the tests are to comply with the requirements of Tab 3, as appropriate.

The chemical analysis of the deposited weld metal in each test assembly is to be supplied by the Manufacturer and is to include the content of all significant alloying elements, if any.

**Figure 1 : Deposited metal test assembly**

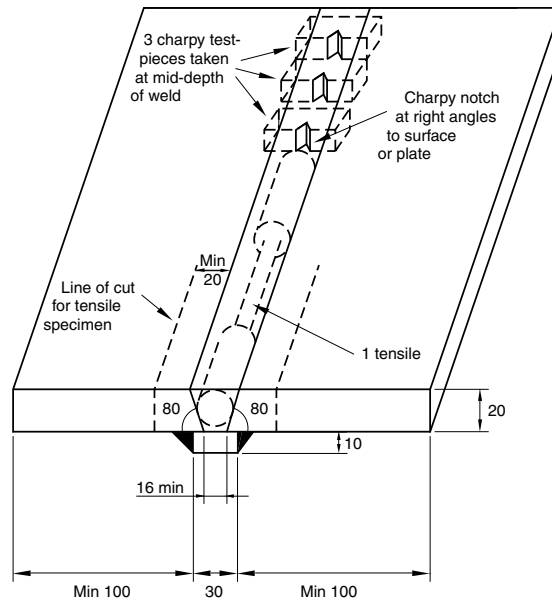

All the dimensions are in mm, unless otherwise indicated.

**Table 1 : Test assemblies and mechanical tests required**

Test assembly						Tests required (1)
Type	Welding position (2)	Electrode diameter (mm) (3)	Number of samples	Thickness (mm)	Dimensions	
Deposited metal	Flat	4	1 (4)	20	Fig 1	1TL-3KV
		max.	1			
Butt weld	Flat	First run: 4 - Intermediate: 5 Last two layers: max	1 (5)	15 - 20	Fig 2	1TT-1RB-1FB-3KV
	Vertical upward	First run: 3,25 Remaining runs: 4	1			1TT-1RB-1FB-3KV
	Horizontal (6)	First run: 4 Remaining runs: 5	1			1TT-1RB-1FB-3KV
	Overhead	First run: 3,25 Remaining runs: 4	1			1TT-1RB-1FB
Fillet (7)		First side: min. diam.	1	15 - 20	Fig 3, Fig 4	Macro- Fracture-Hardness
		Second side: max.diam.				

- (1) Abbreviations: TL: longitudinal tensile test; TT: transverse tensile test; RB: root bend test; FB: face bend test; KV: Charpy V-notch impact test.
- (2) When the approval is requested only for one or more specified welding positions, the butt test samples are to be welded in such positions.
- (3) In the case of high efficiency ( $\geq 130$ ) electrodes, electrodes having diameter 3,25 mm and 4 mm are to be used instead of 4 mm and 5 mm, respectively.
- (4) If only one diameter is to be approved, only one test assembly is required.
- (5) For electrodes to be approved in flat position only, an additional test sample is to be welded using electrodes having diameter 4 mm for the first pass, 5 mm for the second pass and the maximum diameter to be approved for the following passes.
- (6) The test sample in the horizontal position is not required when the same test sample is welded in flat and vertical positions.
- (7) See [1.5].

**1.3.3 Butt weld tests**

Butt weld test assemblies as shown in Fig 2 are to be welded as indicated from a) to e).

- a) Flat position
  - one test sample welded using 4 mm electrodes for the first pass, 5 mm electrodes for the intermediate passes, and electrodes of the maximum diameter to be approved for the last two passes
  - one test sample welded using 4 mm electrodes for the first pass, 5 mm electrodes for the second pass, and electrodes of the maximum diameter to be approved for the remaining passes. This additional test sample is required in the case of electrodes to be approved for the flat position only.
- b) Vertical position upward technique
 

one test sample welded using 3,25 mm electrodes for the first pass and 4 mm electrodes for the remaining passes, or 5 mm if this is recommended by the Manufacturer for welding in vertical position
- c) Vertical position downward technique
 

one test sample welded using electrode diameters recommended by the Manufacturer, when the approval with the downward technique has been requested
- d) Overhead position
 

one test sample welded using 3,25 mm electrodes for the first pass and 4 mm electrodes (or possibly 5 mm if this is recommended by the Manufacturer) for the remaining passes
- e) Horizontal position
 

one test sample welded using 4 mm electrodes for the first pass and 5 mm electrodes for the remaining passes. This test sample need not be welded in the case of electrodes for which the execution of the same test sample in flat and vertical positions is required.

The grade of steel to be used for the preparation of the test assemblies is related to the grade of the electrodes as indicated in Tab 2.

For electrodes to be approved under grades 4 and 5, in lieu of the hull steels specified in Tab 2, C-Mn steels for pressure vessels of grades L40 and L60, respectively, and strength appropriate to the electrode strength may be used.

The use of other type of steel is to be agreed with the Society on a case-by-case basis.

The welding is to be performed with the usual technique in compliance with the requirements specified in [1.3.2] for the deposited metal test, as applicable. For all assemblies, the back sealing run is to be made with 4 mm diameter electrodes, in the welding position appropriate to each test sample, after back gouging to sound metal. For electrodes suitable for downhand welding only, the test assemblies may be turned over to carry out the backing seal.

After being welded, the test assemblies are not to be subjected to any heat treatment except where approval has been requested also in the stress relieved condition [1.3.5]. In such case the symbol D is to be added to the grade designation.

It is recommended and may be required that the welded assemblies should be subjected to a radiographic examination to ascertain if there are any defects in the weld prior to the preparation of test specimens.

The test specimens shown in Fig 2 are to be taken for the following tests:

- a) one transverse tensile test
- b) three Charpy V-notch impact tests
- c) one root and one face bend test specimens.

**Table 2 : Grade of steel used for test assemblies**

Electrode grade	Steel grade (1)
1	A
2	A, B, D
3 - 4	A, B, D, E
2Y	AH32-36, DH32-36
3Y	AH32-36, DH32-36, EH32-36
4Y- 5Y	AH32-36, DH32-36, EH32-36, FH32-36
2Y40	AH40, DH40
3Y40	AH40, DH40, EH40
4Y40 - 5Y40	AH40, DH40, EH40, FH40
<b>(1)</b> The tensile strength of grades AH32 to FH32 is to be greater than 490 N/mm <sup>2</sup> .	

Figure 2 : Butt weld test assembly

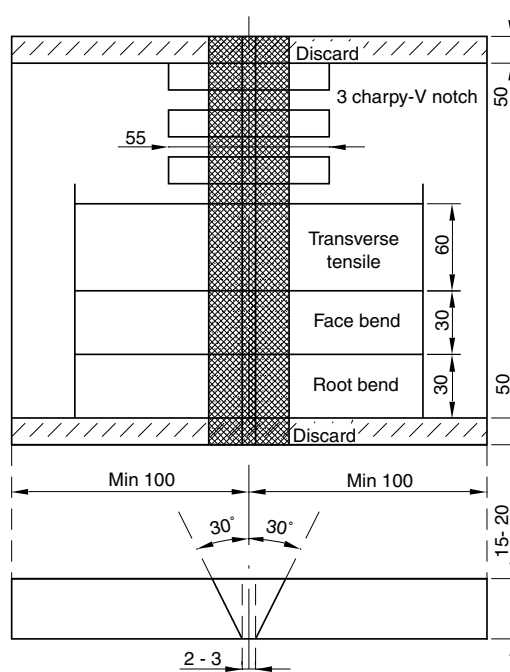

All the dimensions are in mm, unless otherwise indicated.

**1.3.4 Test requirements**

The required results of tensile and impact tests on deposited metal and butt weld tests are indicated in Tab 3.

Bend tests are to be performed on a mandrel having a diameter equal to three times the thickness of the specimen; the results are to comply with requirements in Sec 1, [5.3.1].

**1.3.5 Approval in the stress relieved condition**

When the approval of the electrode is required with the additional symbol D, relevant to the checking of the mechanical properties in the stress relieved condition, the following additional tests are to be performed on samples submitted to stress relieving in the furnace for 1 hour at 600-650°C:

- one longitudinal tensile test and 3 Charpy V-notch impact tests on the deposited metal test assembly welded with the maximum diameter to be approved
- alternatively or in addition, at the Surveyor’s discretion, 3 Charpy V-notch impact tests on the butt weld test welded in flat and vertical position.

The impact tests are to be carried out at the temperature specified for the respective grades of electrodes.

**Table 3 : Mechanical properties**

Grade	Tensile test on deposited metal			Tensile test on butt weld	Charpy V-notch impact test Minimum average energy (J)		
	Yield stress $R_{eH}$ (N/mm <sup>2</sup> ) min.	Tensile strength $R_m$ (N/mm <sup>2</sup> )	Elong. $A_5$ (%) min.	Tensile strength $R_m$ (N/mm <sup>2</sup> ) min.	Test temp. (°C)	Flat, Horizontal, Overhead	Vertical
1	305	400 - 560	22	400	+ 20	47	34
2					0		
3					- 20		
4					- 40		
2Y	375	490 - 660	22	490	0	47	34
3Y					- 20		
4Y					- 40		
5Y					- 60		
2Y40	400	510 - 690	22	510	0	47	39
3Y40					- 20		
4Y40					- 40		
5Y40					- 60		

**1.4 Tests for checking the hydrogen content**

**1.4.1 General**

When electrodes are to be approved with symbol H or H15, HH or H10, HHH or H5, tests are to be carried out to determine the hydrogen content of the weld metal.

Low hydrogen electrodes are subjected to a hydrogen test.

The hydrogen content is to be checked with the mercury method or thermal conductivity detector method according to ISO standard 3690:2018 or another comparable method with the Society’s consent. Four weld assemblies are to be prepared.

The use of the glycerine method described in [1.4.3] may be admitted by the Society for symbols H and HH. For the assignment of the designation HHH, the hydrogen content is, in any case, to be checked with the mercury or thermal conductivity detector method according to the above ISO standard.

**1.4.2 Thermal Conductivity Detector method**

Four weld assemblies are to be prepared.

The temperature of the specimens and minimum holding time are to be complied with Tab 4, according to the measuring method respectively.

**Table 4 : Thermal Conductivity method**

Measuring method		Test temperature (°C)	Minimum holding time (h)
Thermal Conductivity Detector method (1)	Gas Chromatography	45	72
		150	6
(1) The use of hot carrier gas extraction method may be considered subject to verification of the testing procedure to confirm that collection and measurement of the hydrogen occurs continuously until all of the diffusible hydrogen is quantified.			

**1.4.3 Glycerine method**

Four test samples are to be prepared measuring 12 x 25 mm<sup>2</sup> in cross-section by about 125 mm in length. The parent metal may be any grade of structural steel and, before welding, the samples are to be weighed to the nearest 0,1 gram. On the 25 mm width surface of each specimen, a single bead of welding is to be deposited by a 4 mm electrode burning a length of about 150 mm of the electrode. The welding is to be carried out with an arc as short as possible and with current of about 150 amp. Alternating current a.c. is to be used when the electrode is proposed for approval with both a.c. and d.c. Before welding, the electrodes may be submitted to the normal drying process recommended by the Manufacturer.

The procedure for determining the hydrogen content is as follows:

- a) within 30 seconds after the completion of the weld, the slag is to be removed and the samples quenched in water at approximately 20°C
- b) after 30 seconds in water, the samples are to be cleaned and deposited in an apparatus suitable for the collection of the hydrogen by the displacement of glycerin (or paraffin). During the test, the glycerin is to be maintained at 45°C. All four samples are to be welded and subjected to the hydrogen test within 30 minutes
- c) the samples are to be kept soaking in glycerin for 48 hours; after being removed from the machine, the samples are to be cleaned by means of water and alcohol, dried and weighed to the nearest 0,1 gram in order to determine the amount of deposited metal
- d) the amount of gas developed is to be measured to the nearest 0,05 cm<sup>3</sup> and corrected for temperature and pressure to 20°C and 760 mm Hg, respectively
- e) the individual and average diffusible hydrogen content of the four specimens is to be reported and the average value in cm<sup>3</sup>, per 100 grams of deposited metal, is not to exceed the values specified for the symbol of the electrode concerned.

**1.4.4 Hydrogen test requirements**

The hydrogen content is not to exceed the values given in Tab 5.

**Table 5 : Diffusible hydrogen content of weld metal**

Symbol	Diffusible hydrogen content, (ml/100g)	Measuring method (3)
H15 (H)	15 (1)	Mercury method Thermal Conductivity Detector method Glycerine method
H10 (HH)	10 (2)	
H5 (HHH)	5	Mercury method Thermal Conductivity Detector method
(1) 10 ml per 100 grams where the Glycerine method is used.		
(2) 5 ml per 100 grams where the Glycerine method is used.		
(3) Glycerine method is not allowed for the welding consumables with H5 symbol.		

**1.5 Fillet weld test assemblies**

**1.5.1** Fillet weld test assemblies are required for electrodes submitted for approval for fillet welding only and may be required, during the first approval tests at the Surveyor’s discretion, for electrodes submitted for approval for both butt and fillet welding. In the latter case, only one sample in horizontal-vertical position is generally to be welded.

When the electrode is proposed for fillet welding only, fillet weld assemblies for each welding position (horizontal-vertical, vertical upward, vertical downward or overhead) recommended by the Manufacturer and deposited weld metal test as indicated in [1.3.2] are to be welded. The test assemblies, are to have a length L sufficient to allow at least the deposition of the entire length of the electrode being tested.

The grade of steel to be used for the preparation of test assembly is related to the grade of the electrodes as indicated in Tab 2. Plates having a thickness from 15 mm to 20 mm are used.

**1.5.2** The test sample is to be welded on both sides; the first side is to be welded with the maximum diameter and the second side with the minimum diameter. The sizes of the beads are about 9 x 9 and 6 x 6 mm<sup>2</sup> for the first and second beads, respectively.

**1.5.3** After visual examination and assessment, three sections for macrographic examination are to be taken from each test sample as indicated in Fig 3 (one in the middle and one at each end). These are to be examined for root penetration, satisfactory profile, freedom from cracking and reasonable freedom from porosity and slag inclusions.

Vickers hardness measurements are to be carried out to the Surveyor’s satisfaction on the above sections in the positions indicated in Fig 4.

The hardness of the weld metal obtained is to be:

- ≥ 120 HV for normal strength level
- ≥ 150 HV for high strength level up to  $R_{eH} = 355 \text{ N/mm}^2$
- ≥ 170 HV for high strength level up to  $R_{eH} = 390 \text{ N/mm}^2$ .

The hardness of both heat affected zone H.A.Z. and base metal is also to be determined and is to be reported for information.

**Figure 3 : Sections for macrographic examination**

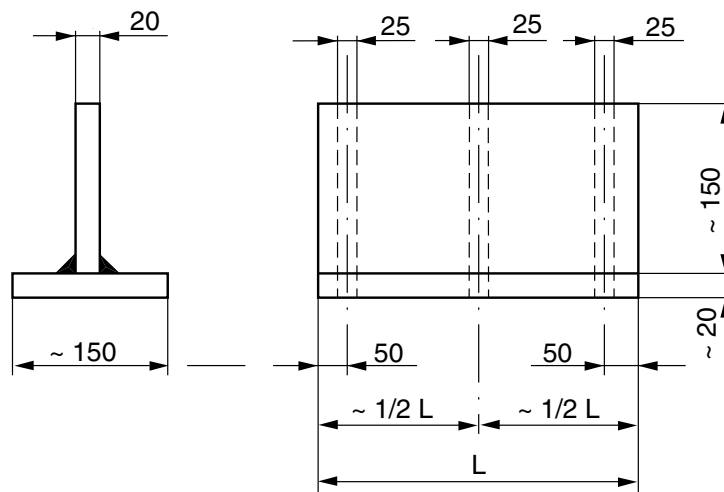

**Figure 4 : Hardness readings**

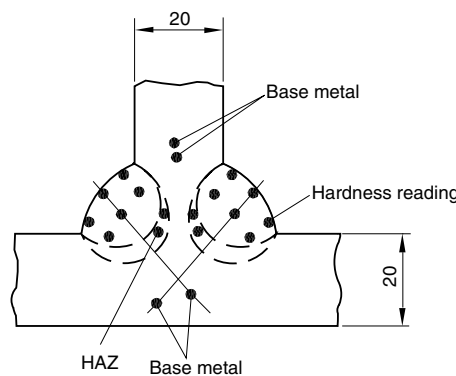

The dimensions are in mm.



**1.5.4** One of the remaining sections of the fillet weld is to have the weld on the first side gouged or machined to facilitate the breaking the fillet weld, on the second side by closing the two plates together, submitting the root of the weld to tension. On the other remaining section, the weld on the second side is to be gouged or machined and the section fractured using the same procedure.

The fractured surfaces are to be examined for root penetration, satisfactory profile, freedom from cracks and reasonable freedom from porosity.

### 1.6 Annual control tests

**1.6.1** The annual tests are to include at least the following:

- a) two deposited metal test assemblies are to be prepared in accordance with [1.3.2] and the required tests (one longitudinal tensile test and 3 Charpy V-notch impact tests) are to be conducted. For electrodes approved for fillet weld only, and not suitable for butt-joints, only one deposited metal test with the maximum diameter is to be carried out
- b) at the discretion of the Society, a butt weld test to be welded in vertical position may be required in lieu of the deposited metal test with electrodes of 4 mm
- c) the check of the hydrogen content is required for electrodes approved with symbol HHH (or H5) and may be required for electrodes approved with symbol HH (or H10)
- d) the chemical composition may be required to be checked under conditions corresponding to those of the approval tests.

The welding and test procedures, the type of current, the materials, the test results and the re-test procedures, where applicable, are regulated by the requirements relative to the approval tests.

# Section 3 Covered Electrodes for Gravity or Contact Welding

## 1 Requirements

### 1.1 Scope

**1.1.1** The requirements of this Section apply to covered electrodes when submitted for approval for use in gravity welding, using automatic gravity or similar welding devices.

### 1.2 Approval tests

**1.2.1** Where the electrode is submitted for approval for the gravity welding technique only, deposited metal tests Sec 2, [1.3.2], fillet weld tests Sec 2, [1.5] and, where appropriate, butt weld tests Sec 2, [1.3.3] similar to those for manual electrodes are to be carried out with such technique.

**1.2.2** Where the electrode is submitted for approval for the gravity welding technique in addition to normal manual welding, fillet weld tests and, where appropriate, butt weld tests are to be carried out with the gravity process, in addition to the normal approval tests.

**1.2.3** The fillet weld test is to be gravity welded using the longest size of electrode manufactured. The Manufacturer's recommended current range is to be reported for each electrode size.

The results of the tests are to comply with the requirements specified in Sec 2, [1.5.3] and Sec 2, [1.5.4].

### 1.3 Annual control tests

**1.3.1** Where the electrode is approved only for gravity welding, the annual test is to consist of at least one deposited weld metal test assembly using such process. If the electrode is approved also for manual arc welding, the annual test is to be performed as indicated in Sec 2, [1.6.1].

# Section 4 Covered Electrodes for Deep Penetration Manual Welding of C and C-Mn Steels

## 1 Requirements

### 1.1 Scope

**1.1.1** The requirements of this Section apply to deep penetration electrodes to be used for downhand butt and fillet welding and horizontal-vertical fillet welding.

Deep penetration electrodes may be approved as grade 1 electrodes only and are to be given the additional symbol D.P.

Approvals limited to butt-joints only may be considered. In these cases, the test sample specified in [1.2.2] is not required.

**1.1.2** The welding of butt-joints in flat position is to be performed on square groove edges.

When the Manufacturer requires that the approval is extended to cover butt-welded joints having a single Vee edge preparation, all the tests required in Sec 2 for normal type electrodes used in flat position are to be carried out, in addition to the tests required in this Section.

**1.1.3** Test samples relative to the approval of deep penetration electrodes are to be welded with the type and the intensity of current recommended by the Manufacturer.

When it is intended that the approval is valid for use with both d.c. and a.c. currents, the test samples are to be welded with a.c. current.

**1.1.4** As regards the procedure for the approval, the preparation and welding of samples, the specimens and testing, the requirements specified in Sec 2 for ordinary electrodes are to be complied with, in so far as applicable.

### 1.2 Approval tests

#### 1.2.1 Butt weld test assembly

The following test sample in grade A structural steel or equivalent steel to the Surveyor's satisfaction is to be welded:

- one butt-welded sample, with square groove edges, made of two plates having width  $\geq 100$  mm and a thickness equal to twice the diameter of the core of the electrode plus 2 mm; such sample is to be welded in flat position with the maximum electrode diameter for which the approval has been requested, with a single pass on each side (see Fig 1).

The edges are to be accurately cut and in good contact (not more than 0,25 mm between edges for the full length of the joint).

The specimens for the following tests are to be taken after having discarded a length of 35 mm from each end:

- two transverse tensile tests
- one face and one root bend
- three Charpy V-notch impact tests
- two macrographic examinations.

#### 1.2.2 Fillet weld test assembly

The following test sample in grade A structural steel or equivalent steel to the Surveyor's satisfaction is to be welded:

- one Tee-joint sample having length  $\geq 160$  mm and thickness about 12-15 mm, to be welded in horizontal position with a 4 mm electrode on one side and with an electrode of the maximum diameter to be approved on the other side.

The edges are to be accurately cut and the gap between the plates is to be not more than 0,25 mm for the full length of the joint as shown in Fig 2.

Two cross-sections are to be obtained from the sample at about 35 mm from each end; the two cross-sections are to be subjected to a macrographic examination (see Fig 2).

#### 1.2.3 Test requirements

The results required for the tests mentioned in [1.2.1] and [1.2.2] are specified in the following items a) and b):

a) Butt weld test assembly:

- bend tests on a mandrel having diameter equal to three times the thickness of the sample: bend angle  $\alpha \geq 120^\circ$
- transverse tensile test:  $R_m \geq 410$  N/mm<sup>2</sup>
- impact tests at about +20°C; minimum absorbed energy (average value of three tests): KV  $\geq 47$  J
- the macrographic examinations are to show a complete compenetration of the welds on the two sides.

b) Fillet weld test assembly:

- the fillet deposited with the 4 mm electrode is to show a penetration not less than 4 mm (see Fig 2)
- the penetration obtained by the fillet deposited with the maximum diameter of electrode on the other side is to be measured and reported for information purposes only.

**1.2.4 Maximum thickness which can be welded**

Upon satisfactory completion of the tests mentioned in the above paragraphs, the Manufacturer is to prepare and submit to the Society a table showing the maximum thickness which can be welded, with square groove edges, with each diameter of electrode included in the approval and with the intensity of current necessary for the relevant electrode.

The table, which forms an integral and essential part of the approval documentation, is to substantially conform to the maximum thickness value verified in the test in [1.2.1].

**1.3 Annual control tests**

**1.3.1** One test sample, as illustrated in Fig 1 or Fig 2 as applicable, is required; such sample is to be welded with electrodes having the maximum approved diameter.

The required tests and the relevant requirements are those indicated in [1.2.1], [1.2.2] and [1.2.3]; however, only one transverse tensile test is required.

For electrodes approved for both normal and deep penetration welding in the downhand position, a deep penetration weld test, as above, is to be carried out in addition to the deposited weld metal tests required for normal penetration.

**Figure 1 : Deep penetration butt weld test assembly**

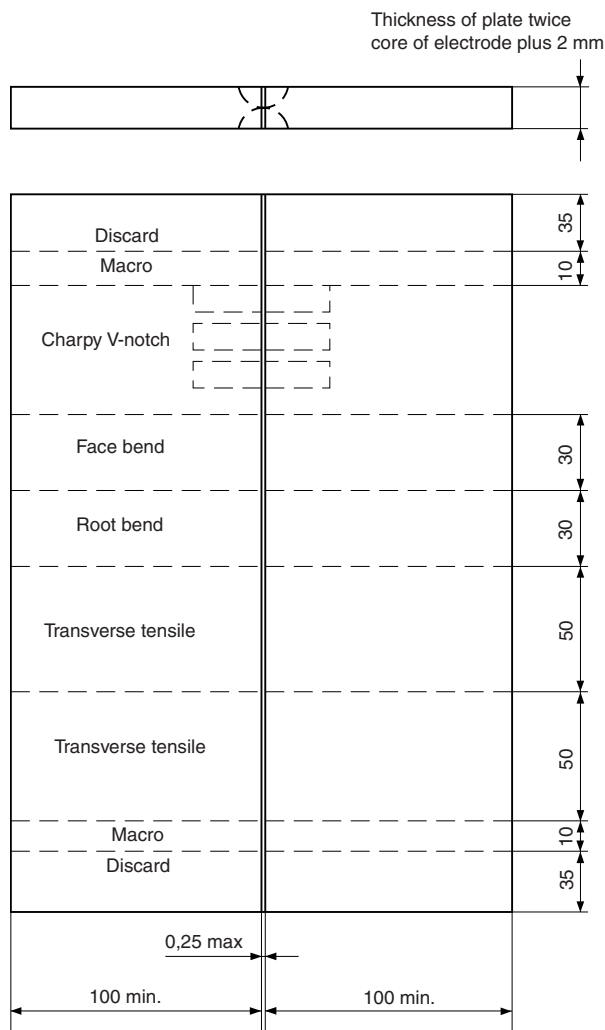

All the dimensions are in mm.

Figure 2 : Deep penetration fillet weld test assembly

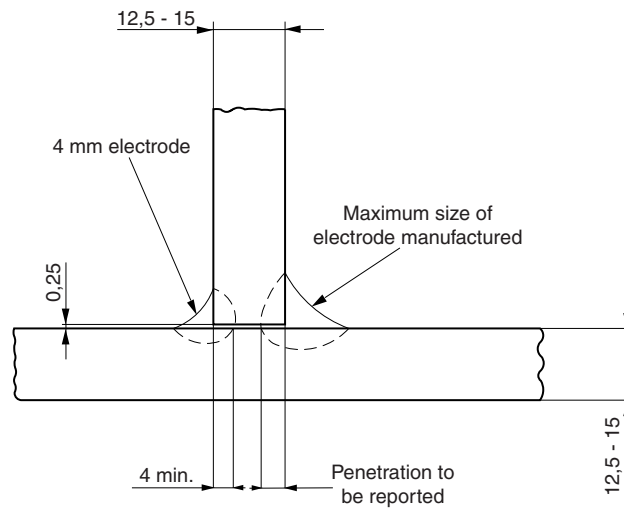

# Section 5 Flux-Wire Combination for Submerged Arc Welding of C and C-Mn Steels

## 1 Requirements

### 1.1 Scope

1.1.1 The requirements of this Section apply to wire flux combination for submerged arc welding of hull structural steels, of the corresponding grades of steel forgings and castings and of comparable steels intended for other structural applications or pressure systems.

Approvals granted in accordance with these requirements are valid for standard single wire welding.

Other techniques, such as tandem or multi-wire welding, and one side welding on flux or backing, are to be submitted to separate approval tests. These tests are generally to be carried out in accordance with the requirements of this Section and are detailed, on a case-by-case basis, depending on the welding procedure proposed.

### 1.1.2 Type of wires

Types of wires identified by the chemical composition shown in Tab 1 are generally to be used.

Chemical composition of wires other than those given in Tab 1 are to be submitted.

### 1.1.3 Designation

Wire flux combinations are divided, for the various strength levels, into the following grades as defined in Sec 1, [2.2.1]:

- a) 1, 2, 3, 4 for normal strength grades
  - b) 1Y, 2Y, 3Y, 4Y, 5Y for high strength grades with specified minimum yield strength up to 355 N/mm<sup>2</sup>
  - c) 2Y40, 3Y40, 4Y40, 5Y40 for high strength grades with specified minimum yield strength up to 390 N/mm<sup>2</sup>.
- The prefix A is added to the grade.

Depending on the welding technique, the following symbols are added as a suffix to the grade:

- T for use with two-run technique
- M for use with multi-run technique
- TM for use with both techniques.

### 1.1.4 Information and documentation to be submitted

The following information and supporting documentation, as applicable, are generally to be submitted together with the request for approval:

- a) commercial name of the flux, for which the approval is requested; type of flux (fused or conglomerate)
- b) commercial name of the associated wire, limits of chemical composition and diameters to be approved
- c) grading under which the approval is requested; type of current and welding positions
- d) typical chemical composition of the deposited metal, with particular reference to the contents of Mn, Si and alloying elements
- e) recommendations, where applicable, regarding the range of the welding parameters (current, voltage and welding speed)
- f) previous approvals granted to the proposed wire-flux combination.

**Table 1 : Wire chemical composition**

Type of wire	Chemical composition									
	C max.	Mn	Si max.	P max.	S max.	Al max.	Cr max.	Ni max.	Cu max.	Mo
1	0,13	0,40 - 0,65	0,15 <b>(2)</b>	0,03	0,03	0,03	0,15	0,25	0,30	<b>(3)</b>
2	0,15	0,80 - 1,20								
3	0,15	1,30 - 1,70								
4	0,15	1,80 - 2,20 <b>(1)</b>								
5	0,16	2,30 - 2,70								

**(1)** A content lower by not more than 0,05% is acceptable.  
**(2)** Wires having chemical composition 1 may be of rimmed steel; the other wires may be of Si and/or Al killed or semi-killed steels. Approval may be granted to wires having Si content up to 0,40%, depending on the type of wire concerned.  
**(3)** For all wires Mo may be included in the proposed composition in the range 0,45-0,60%; the content is to be stated by the Manufacturer at the time of the request for approval of the wire-flux combination.

1.2 Approval tests

1.2.1 General

The test assemblies required for approval are specified in [1.2.2] to [1.2.7] and summarised in Tab 2, depending on the welding technique to be approved.

A few preliminary samples may be required by the Surveyor to be welded, in order to check the operating characteristics and set up the welding parameters.

1.2.2 Multi-run technique (M)

Where approval for use with multi-run technique is requested, deposited weld metal and butt weld tests are to be carried out as indicated in [1.2.3] and [1.2.4], respectively.

1.2.3 Deposited metal test

One deposited metal test is to be welded, as shown in Fig 1, in general with a wire having diameter of 4 mm.

Any grade of ship structural steel may be used for the preparation of the test assembly.

The welding conditions (amperage, voltage and travel speed) are to be in accordance with the recommendations of the Manufacturer and are to conform with normal good welding practice.

The weld metal is deposited in multi-run layers and the direction of deposition of each layer is in general to alternate from each end of the plate. After completion of each run, the flux and welding slag are to be removed. Between each run, the assembly is to be left in still air until it has cooled to less than 250°C but not below 100°C, the temperature being taken in the centre of the weld on the surface of the seam. The thickness of each layer is to be neither less than the diameter of the wire nor less than 4mm. After being welded, the test assemblies are not to be subjected to any heat treatment, except where approval has also been requested in the stress relieved condition. In such case the symbol D is to be added to the grade designation.

The specimens shown in Fig 1 are to be taken for the following tests:

- a) two longitudinal tensile tests
- b) three Charpy V-notch impact tests.

The results of the tests are to comply with the requirements of Tab 5, as appropriate.

The chemical analysis of the deposited weld metal of the test assembly is to be supplied by the Manufacturer and is to include the content of all significant alloying elements, if any.

Figure 1 : Deposited metal test

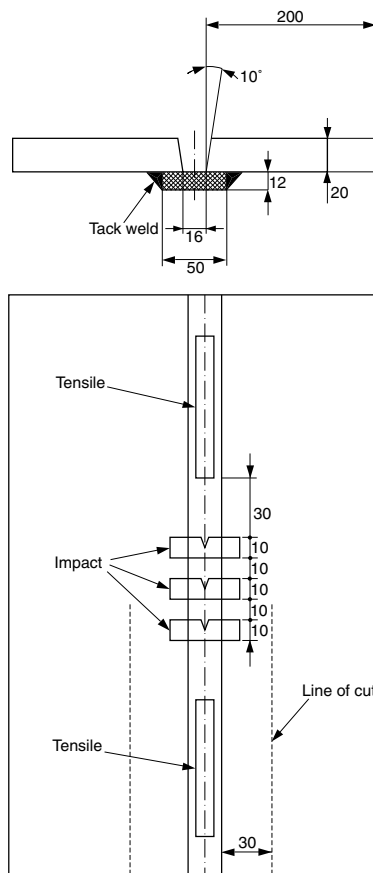

All the dimensions are in mm, unless otherwise indicated.

**Table 2 : Test assemblies and mechanical tests required**

Welding technique	Test assembly				Tests required (1)
	Type	Number	Thickness (mm)	Dimensions	
M	Deposited metal test	1	20	Fig 1	2TL - 3KV
	Butt weld test	1	20 - 25	Fig 2	2TT - 2RB - 2FB - 3KV
T	Butt weld test	1	12 - 15	Fig 4	2TT - 2RB - 2FB - 3KV
	Butt weld test	1	20 - 25	Fig 4	1TL - 2TT - 2RB - 2FB - 3KV
	Butt weld test	1	30 - 35	Fig 4	1TL - 2TT - 2RB - 2FB - 3KV
TM					(2)
<p>(1) Abbreviations: TL = longitudinal tensile test; TT = transverse tensile test; RB = root bend test; FB = face bend test; KV = Charpy V-notch impact test.</p> <p>(2) Tests for both techniques are required; only one longitudinal tensile test is required on the deposited metal test.</p>					

**1.2.4 Butt weld tests for multi-run technique**

One butt weld test assembly is to be welded as shown in Fig 2 in general with a wire having diameter of 4 mm.

The grade of steel to be used for the preparation of the test assemblies is related to the grade of the wire-flux combination as indicated in Tab 3.

At the discretion of the Society, approval of multi-run welding of both normal and higher strength steel may be obtained by making a butt weld on higher tensile steel only.

For flux to be approved under grades 4 and 5, in lieu of the hull steels specified in Tab 3, C-Mn steels for pressure vessels of grades L40 and L60, respectively, and strength appropriate to the wire flux combination strength may be used.

The use of other types of steel is to be agreed with the Society on a case-by-case basis.

The welding is to be performed by the multi-run technique and the welding conditions are to be the same as those adopted for the deposited weld metal assembly. The back sealing run is to be made with the welding parameters used for the filling pass, after back gouging to sound metal.

After being welded, the test assemblies are not to be subjected to any heat treatment except where approval has also been requested in the stress relieved condition [1.2.7]. In such case the symbol D is to be added to the grade designation.

It is recommended that the welded assemblies should be subjected to a radiographic examination to ascertain if there are any defects in the weld prior to the preparation of test specimens.

The test specimens, shown in Fig 2, are to be taken for the following tests:

- a) two transverse tensile tests
- b) three Charpy V-notch impact tests
- c) two root and two face bend tests.

The results of the tests are to comply with the requirements of [1.2.6], as appropriate.

**Table 3 : Grade of steel used for test assemblies**

Wire flux combination grade	Steel grade (1)
1	A
2	A, B, D
3 - 4	A, B, D, E
1Y	AH 32-36
2Y	AH 32-36, DH 32-36
3Y	AH32-36, DH32-36, EH32-36
4Y - 5Y	AH32-36, DH32-36, EH32-36, FH32-36
2Y40	AH40, DH40
3Y40	AH40, DH40, EH40
4Y40 - 5Y40	AH40, DH40, EH40, FH40
(1) The tensile strength of grades AH32 to FH32 is to be greater than 490 N/mm <sup>2</sup> .	



Figure 2 : Butt weld test assembly

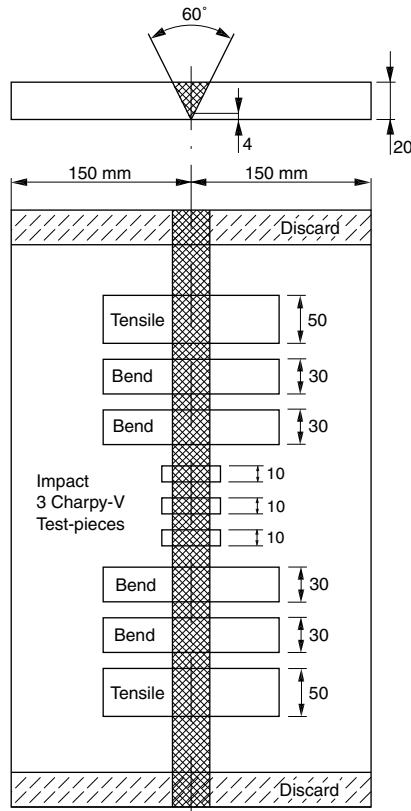

All the dimensions are in mm, unless otherwise indicated.

**1.2.5 Two-run technique (T)**

Where approval for use with two-run technique only is requested, two butt weld test assemblies are to be carried out as indicated in Tab 4 and no deposited metal test is requested.

The grade of steel to be used for the preparation of the test assemblies is related to the grade of the wire flux combination as indicated in Tab 3.

Each strength level requires separate approval.

For flux to be approved under grades 4 and 5, in lieu of the hull steels specified in Tab 3, C-Mn steels for pressure vessels of grades L40 and L60, respectively, and strength appropriate to the wire flux combination strength may be used.

The use of other types of steel is to be agreed with the Society on a case-by-case basis.

The welding is to be performed in two runs, one from each side, using voltage and travel speed in accordance with the recommendation of the Manufacturer and normal good welding practice. In general, the following values of current parameters are to be complied with for welding the second run:

- 700-800 A for samples having thickness 12-15 mm
- 900-1000 A for samples having thickness 20-25 mm
- 1100-1200 A for samples having thickness 30-35 mm.

After the completion of the first run, the flux and welding slag are to be removed and the assembly left in still air until it has cooled to 100°C, the temperature being taken in the centre of the weld, on the surface of the seam.

After being welded, the test assemblies are not to be subjected to any heat treatment except where approval has also been requested in the stress relieved condition. In such case the symbol D is to be added to the grade designation.

The test assemblies are to be subjected to radiographic examination to ascertain freedom from lack of penetration or other defects in the weld, prior to the preparation of test specimens.

The test specimens, shown in Fig 4, are to be taken for the following tests:

- a) two transverse tensile tests
- b) three Charpy V-notch impact tests
- c) two root and two face bend tests.

Where the approval is required for two-run technique only, one longitudinal tensile specimen is to be taken from the thicker plate, as shown in Fig 4.

The results of the tests are to comply with the requirements of [1.2.6], as appropriate.

The chemical analysis of the weld metal of the second run in each test assembly is to be supplied by the Manufacturer and is to include the content of all significant alloying elements, if any.

Table 4 : Two-run technique butt weld test assemblies

Grade	Plate thickness (mm)	Recommended preparation (2)	Maximum diameter of wire (mm)
1 - 1Y	12 - 15	Fig 3 (a)	5
	20 - 25	Fig 3 (b)	6
2, 3, 4, 2Y, 3Y, 4Y, 5Y,	20 - 25 (1)	Fig 3 (b)	6
2Y40, 3Y40, 4Y40, 5Y40	30 - 35 (1)	Fig 3 (c)	7

(1) A limitation of the approval to the lower and medium thickness range (up to the maximum welded plate thickness) may be agreed to by the Society and the test pieces are then to be welded from plates of thickness 12-15 mm and 20-25 mm, irrespective of the quality grade.

(2) Minor deviations in the weld preparation are admissible; the root gap is to be practically constant and generally is not to exceed 0,7 mm.

Figure 3 : Recommended edge preparation for two-run technique

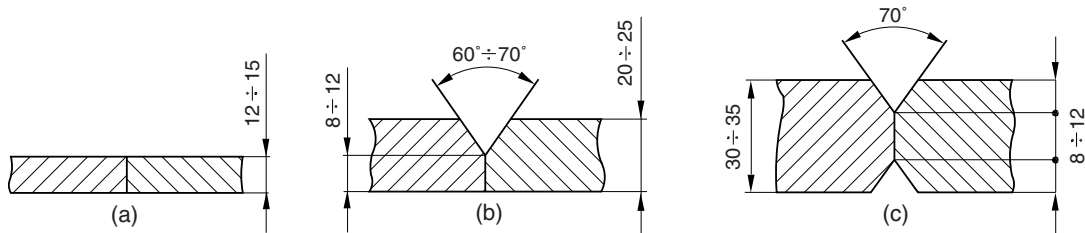
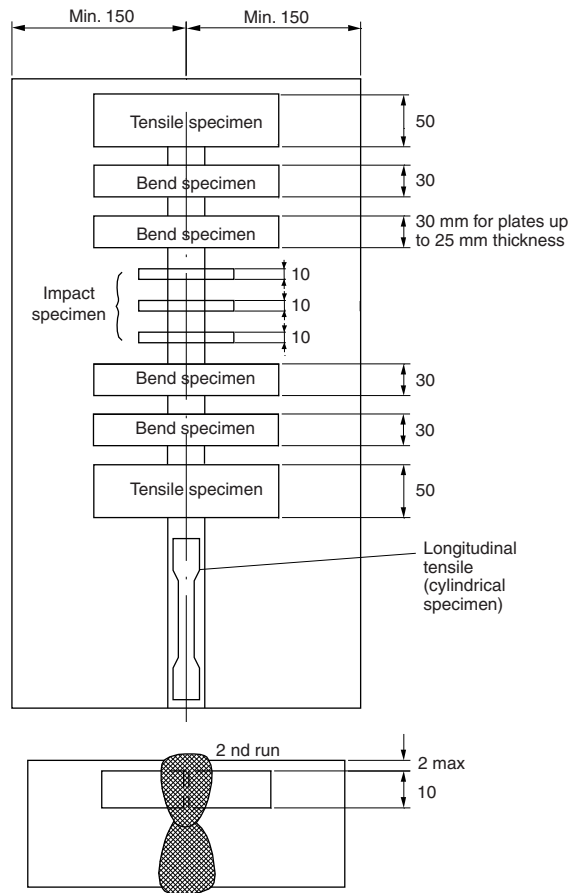

Figure 4 : Butt weld test assembly for two-run technique



All the dimensions are in mm.

**Table 5 : Required mechanical properties**

Grade	Tensile test on deposited metal			Tensile test on butt weld	Charpy V-notch impact test	
	Yield stress $R_{eH}$ (N/mm <sup>2</sup> ) min.	Tensile strength $R_m$ (N/mm <sup>2</sup> )	Elong. $A_5$ (%) min.	Tensile strength $R_m$ (N/mm <sup>2</sup> ) min.	Test temp. (°C)	Minimum average energy (J)
1	305	400 - 560	22	400	+ 20	34
2					0	
3					- 20	
4					- 40	
1Y	375	490 - 660	22	490	+ 20	34
2Y					0	
3Y					- 20	
4Y					- 40	
5Y					- 60	
2Y40	400	510 - 690	22	510	0	39
3Y40					- 20	
4Y40					- 40	
5Y40					- 60	

**1.2.6 Tests requirements**

The required results of tensile and impact tests on deposited metal and butt weld tests are indicated in Tab 5.

Bend tests are to be performed on a mandrel having a diameter equal to three times the thickness of the specimen; the results are to comply with requirements in Sec 1, [5.3.1].

**1.2.7 Approval in the stress relieved condition**

When the approval of the wire flux combination is required with the additional symbol D, relevant to the checking of the mechanical properties in the stress relieved condition, the following additional tests are to be carried out on samples submitted to stress relieving in the furnace for one hour at 600-650°C:

- a) Two-run technique (T)
  - one longitudinal and one transverse tensile test, three Charpy V-notch impact tests on the face and root side of the butt welded assembly having the maximum thickness.
- b) Multi-run technique (M)
  - one longitudinal tensile test on the deposited metal test and one transverse tensile test on the butt weld test
  - three Charpy V-notch impact tests on deposited metal and butt weld tests.

**1.3 Annual control tests**

**1.3.1** The periodical control tests are to include at least the following:

- a) two-run technique (T)
  - one butt weld test assembly with plate thickness 20-25 mm from which one transverse tensile, two bend tests (one root and one face bend) and three impact tests are to be taken. One longitudinal tensile test is also to be prepared for wire flux combinations approved solely for the two-run technique.
- b) multi-run technique (M)
  - one deposited metal test assembly from which one all weld metal longitudinal tensile test and three Charpy V-notch impact tests are to be taken.
- c) T and M techniques (TM)
  - the test assemblies and relevant tests required for T and M techniques are to be carried out. The longitudinal tensile test specified in a) for T technique is not required.

**1.3.2** The weld and test procedures, the type of current, the materials, the test results and the re-test procedures, where applicable, are regulated by the requirements relative to the approval tests.

Where a wire flux combination is approved for welding both normal strength and higher strength steels, the steels of the highest strength approved are to be used for the preparation of the butt weld assembly required by the T technique, in order to also cover the lower strength levels.

## Section 6

# Flux-Wire Combinations for One Side Submerged Arc Welding of Butt-Joints of C and C-Mn Steels

## 1 Requirements

### 1.1 Scope

**1.1.1** The requirements of this Section apply to flux-wire combinations for submerged-arc welding processes with high current, used for one side welding (U welding technique) of butt-joints with one or more layers (in general not more than two layers).

The welding machine may have one or more welding heads. A suitable backing support, for example a flux layer and support equipment, may be adopted.

The requirements of Sec 5 are also to be complied with, as applicable, unless otherwise stated in this Section.

### 1.2 Designation

**1.2.1** The prefix A and the suffix U are added to the grade as defined in Sec 1, [2.7.1].

### 1.3 Approval tests

**1.3.1** The edge preparation of the various samples and the welding parameters to be used are those proposed by the Manufacturer and they are to be reported in the approval certificate; they are to be appropriate to ensure complete fusion and satisfactory surface appearance.

The specimens which are required to be obtained from the samples are the same as indicated in Sec 5, [1.2.5] except for impact test specimens, which are to be taken as follows (see Fig 1):

- a) for samples of thickness  $s = 12-15$  mm:  
3 specimens at mid-thickness
- b) for samples of thickness  $s = 20-25$  mm:  
6 specimens, 3 near each surface
- c) for samples of thickness  $s = 30-35$  mm:  
9 specimens, 3 near each surface and 3 at mid-thickness.

**Figure 1 : Position of Charpy V-notch impact test for one side automatic welding**

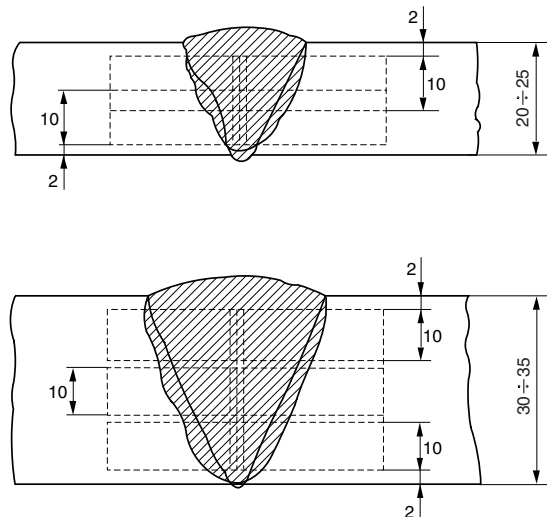

# Section 7 Wires and Wire-Gas Combination for Semiautomatic Welding of C and C-Mn Steels

## 1 Requirements

### 1.1 Scope

**1.1.1** The requirements of this Section apply to bare wire gas combinations and flux cored or flux coated wires with or without shielding gases, to be used for semiautomatic welding of hull structural steels, of the corresponding grades of steel forgings and castings and of comparable steels intended for other structural applications or pressure systems.

The term semiautomatic is used to describe processes in which the weld is made manually by a welder holding a gun through which the wire is continuously feed. For the purpose of the approval designation, this technique is identified by the symbol S or SA.

### 1.2 Type of wires

**1.2.1** The chemical composition of bare wires normally used is shown in Tab 1.

Types G3Si1 and G4Si1 are particularly intended for welding processes under CO<sub>2</sub> shielding gas and the other types for welding processes where mixtures of shielding gases are used.

Chemical composition of wires other than those given in Tab 1 are to be submitted to the society.

### 1.3 Shielding gases

**1.3.1** Where applicable, the composition of the welding gas is to be reported.

For the purpose of the approval, the type of gas and mixture of gas are grouped as indicated in Tab 2.

Unless otherwise required for specific applications, gas mixtures in the same group are considered equivalent for approval purposes.

### 1.4 Designation

**1.4.1** Wire gas combinations are divided, for the various strength levels, into the following grades as defined in Sec 1, [2.2.1]:

- a) 1, 2, 3, 4 for normal strength grades
- b) 1Y, 2Y, 3Y, 4Y, 5Y for high strength grades with specified minimum yield strength up to 355 N/mm<sup>2</sup>
- c) 2Y40, 3Y40, 4Y40, 5Y40 for high strength grades with specified minimum yield strength up to 390 N/mm<sup>2</sup>.

The prefix S or SA is added to indicate semiautomatic welding technique.

**1.4.2** Flux cored or flux coated wires may be required to be submitted to the hydrogen test as detailed in Sec 2, [1.4], using the Manufacturer's recommended welding conditions and adjusting the deposition rate to give a weight of weld deposit per sample similar to that deposited when using manual electrodes.

On the basis of the test results, the welding consumables may be given one of the symbols H (or H15), HH (or H10), HHH (or H5), as appropriate.

**Table 1 : Solid wire chemical composition**

Type of wire	Chemical composition (%) (2)									
	C max	Mn	Si	P max	S max	Cr max	Ni max	Cu max (1)	Mo	
G2Si	0,14	0,90 - 1,30	0,50 - 0,80	0,025	0,025	0,15	0,15	0,35	-	
G3Si1	0,14	1,30 - 1,60	0,70 - 1,00							
G4Si1	0,14	1,60 - 1,90	0,80 - 1,20							
G4Mo	0,14	1,70 - 2,10	0,50 - 0,80							0,40 - 0,60
G4Si	0,14	1,60 - 1,90	0,80 - 1,20							-

(1) Including surface lining  
 (2) Al, Ti, Zr may be added by the Manufacturer and the values are to be submitted to the Society for consideration at the time of the request for the approval; reference may be made to the limits of EN 440.

**Table 2 : Composition of gas mixtures for continuous wire welding process**

Group symbol	Composition of gas mixtures in volume (%)			
	Ar (1)	H <sub>2</sub>	CO <sub>2</sub>	O <sub>2</sub>
C 1			100	–
C2			70 - 99	1 - 30
M11	90 - 98	1 - 5	1 - 5	–
M12	95 - 99		1 - 5	–
M13	97 - 99	–	–	1 - 3
M14	92 - 98	–	1 - 5	1 - 3
M21	75 - 94	–	6 - 25	–
M22	90 - 96	–	–	4 - 10
M23	67 - 93	–	6 - 25	1 - 8
M31	50 - 74	–	26 - 50	–
M32	85 - 89	–	–	11 - 15
M33	35 - 85	–	6 - 50	9 - 15
(1) Argon may be replaced by Helium up to 95% of the argon content.				

**1.5 Information and documentation to be submitted**

**1.5.1** The following information and supporting documentation, as appropriate, are generally to be submitted together with the request for approval:

- a) commercial name, type of wire, limits of chemical composition in the case of bare wires
- b) grading under which the approval is requested; type of current, welding positions
- c) type of shielding gas or gas mixture; commercial brand and Manufacturer, in the case of gas mixtures of special types
- d) typical chemical composition of the deposited metal, with particular reference to the contents of Mn, Si and alloying elements
- e) recommendations, where applicable, regarding the range of the welding parameters (current, voltage and welding speed)
- f) previous approvals granted to the proposed gas wire combination.

**1.6 Approval tests**

**1.6.1 General**

Deposited metal and butt weld tests are to be performed as indicated in [1.6.2] and [1.6.3], and summarised in Tab 3.

A few preliminary samples may be required by the Surveyor to be welded, in order to check the operating characteristics and set up the welding parameters. These tests may be limited to the fillet test assemblies required in [1.6.7].

**1.6.2 Deposited metal test**

Two deposited metal test assemblies are to be welded in the flat position as shown in Sec 2, Fig 1, one using a wire of 1,2mm or the smallest size to be approved and the other using a wire of 2,4 mm or the largest size to be approved. If only one diameter is available, one test assembly is sufficient. Any grade of hull structural steel may be used for the preparation of the test assembly.

The preparation is to be in accordance with Sec 2, Fig 1; however, the angle of the bevel and the gap at the root may be modified depending on the welding process.

The weld metal is to be deposited in multi-run layers according to the normal practice (with wide beads extending for the full width of the bevel), as far as this is correctly feasible, regardless of the diameter of the wire; the direction of deposition of each layer is in general to alternate from each end of the plate, each run of weld metal having thickness in the range 2 mm to 6 mm (compensation included). Between each run the assembly is to be left in still air until it has cooled to less than 250°C but not below 100°C, the temperature being taken in the centre of the weld on the surface of the seam. After being welded, the test assemblies are not to be subjected to any heat treatment except where approval has also been requested in the stress relieved condition. In such case the symbol D is to be added to the grade designation.

The specimens shown in Sec 2, Fig 1 are to be taken for the following tests:

- a) one longitudinal tensile test
- b) three Charpy V-notch impact tests.

The chemical analysis of the deposited weld metal in each test assembly is to be supplied by the Manufacturer and is to include the content of all significant alloying elements, if any.

In general the chemical composition (C, Mn, Si) is determined near the surface of the final pass and is to be reported for information.

**Table 3 : Test assemblies and mechanical tests required**

Test assembly						Tests required (1)
Type	Welding position (2)	Wire diameter (mm)	Number of samples	Thickness (mm)	Dimensions	
Deposited metal	Flat	Max.	1 (3)	20	Sec 2, Fig 1	1 TL - 3KV
		1,2 or min.	1			
Butt weld	Flat	First run: 1,2 or min. Remaining run: max	1 (4)	15 - 20	Fig 1	1TT - 1RB - 1FB - 3KV
	Vertical upward		1			1TT - 1RB - 1FB - 3SB - 3KV
	Vertical downward		1			1TT - 1RB - 1FB - 3SB - 3KV
	Horizontal		1			1TT - 1RB - 1FB - 3SB - 3KV
	Overhead		1			1TT - 1RB - 1FB - 3SB - 3KV
Fillet	(5)	First side: min. diam.	1	15 - 20	Sec 2, [1.5] Sec 2, Fig 3 Sec 2, Fig 4	Macro-Fracture-Hardness
		Second side: max. diam.				

(1) Abbreviations: TL = longitudinal tensile test; TT = transverse tensile test; RB = root bend test; FB = face bend test; SB = side bend test; KV = Charpy V-notch impact test.  
(2) When the approval is requested only for one or more specified welding positions, the butt test samples are to be welded in such positions.  
(3) If only one diameter is to be approved, only one test assembly is required.  
(4) When the approval is requested in flat position only, two test samples are to be welded - the first sample with the maximum wire diameter and the second with increasing diameter from the first to the last pass.  
(5) Fillet weld samples are to be welded in the position required for approval.

**1.6.3 Butt weld tests**

Butt weld test assemblies as shown in Fig 1 are to be welded for each welding position (flat, horizontal, vertical upwards and downwards and overhead) for which the wire gas combination is to be approved.

One test sample is to be welded in downhand position using, for the first run, a wire of 1,2 mm or the smallest diameter to be approved and, for the remaining runs, wires of the maximum diameter to be approved.

Where wires are intended for flat position only, one additional test sample is to be welded, if possible using wires of different diameters from those required above. Where only one diameter is manufactured, only one downhand butt weld assembly is to be prepared.

The other test assemblies are to be welded in the vertical upwards, downwards, horizontal and overhead positions, using for the first run a wire of 1,2 mm or the smallest diameter to be approved, and for the remaining runs the largest diameter to be approved for the position concerned.

The grade of steel to be used for the preparation of the test assemblies is related to the grade of the electrodes as indicated in Sec 2, Tab 2.

For the wires or flux-cored wires to be approved under grades 4 and 5, in lieu of the hull steels specified in Sec 2, Tab 2, C-Mn steels for pressure vessels of grades L40 and L60, respectively, and strength appropriate to the electrode strength may be used.

The use of other types of steel is to be agreed with the Society on a case-by-case basis.

The welding is to be performed with the usual technique in compliance with requirements specified in [1.6.2] for the deposited metal test, as applicable. For all assemblies, the back sealing run is to be made with the same diameter of wire or with the largest diameter of wire used for the weld on the other side.

After being welded, the test assemblies are not to be subjected to any heat treatment except where approval has also been requested in the stress relieved condition. In such case the symbol D is to be added to the grade designation.

It is recommended and may be required that the welded assemblies should be subjected to a radiographic examination to ascertain if there are any defects in the weld prior to the preparation of test specimens.

The specimens shown in Fig 1 are to be taken for the following tests:

- a) one transverse tensile test
- b) three Charpy V-notch impact tests
- c) one face and one root bend tests.

Three additional side bend tests Sec 1, [5.4.1] may be required by the Surveyor to be carried out for samples welded in vertical, horizontal and overhead positions.

**1.6.4 Test requirements**

The required results of tensile and impact tests on deposited metal and butt weld tests are indicated in Tab 4.

Bend tests are to be performed on a mandrel having a diameter equal to three times the thickness of the specimen; the results are to comply with the requirements in Sec 1, [5.3.1].

Figure 1 : Butt weld test assembly

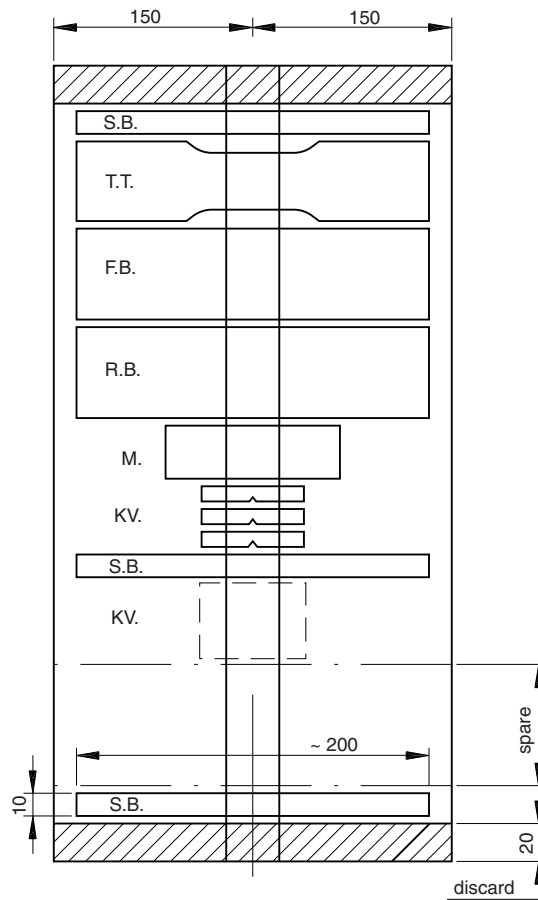

All the dimensions are in mm.

Table 4 : Mechanical properties

Grade	Tensile test on deposited metal			Tensile test on butt weld	Charpy V-notch impact test Minimum average energy (J)		
	Yield stress $R_{eH}$ (N/mm <sup>2</sup> ) min.	Tensile strength $R_m$ (N/mm <sup>2</sup> )	Elong. $A_5$ (%) min.	Tensile strength $R_m$ (N/mm <sup>2</sup> ) min.	Test temp. (°C)	Flat, Horizontal, Overhead	Vertical
1	305	400 - 560	22	400	+ 20	47	34
2					0		
3					- 20		
4					- 40		
1Y	375	490 - 660	22	490	+ 20	47	34
2Y					0		
3Y					- 20		
4Y					- 40		
5Y					- 60		
2Y40	400	510 - 690	22	510	0	47	39
3Y40					- 20		
4Y40					- 40		
5Y40					- 60		



### 1.6.5 Approval in the stress relieved condition

The requirements set forth in Sec 2, [1.3.5] apply.

### 1.6.6 Tests for checking the hydrogen content

When the additional symbols HH (or H10) or HHH (or H5) are required, the provisions under Sec 2, [1.4] apply.

### 1.6.7 Fillet weld test assemblies

Fillet weld test assemblies are generally required in addition to the butt weld test and are to be welded in each of the positions applied for approval (horizontal-vertical, vertical, overhead). The requirements set forth in Sec 2, [1.5] apply, as appropriate.

## 1.7 Annual control tests

1.7.1 The annual tests are to include at least the following assemblies and tests:

- a) One deposited metal test assembly is to be welded in accordance with [1.6.2] with wire having diameter within the range approved, and the required tests (one longitudinal tensile test and three Charpy V-notch impact tests) are to be conducted.
- b) At the discretion of the Society, a butt weld test, to be welded in vertical position, may also be required and three side bend tests and three Charpy V-notch impact tests are to be performed.
- c) For flux cored wire electrodes approved with symbol HH (or H10) or HHH (or H5), the hydrogen content may be required to be checked with the same procedure used in the approval tests.
- d) The chemical composition may be required to be checked under conditions corresponding to those of the approval tests.

The weld and test procedures, the type of current, the materials, the test results and the re-test procedures, where applicable, are regulated by the requirements relative to the approval tests.

# Section 8 Wires and Wire-Gas Combinations for Automatic Welding of C and C-Mn Steels

## 1 Requirements

### 1.1 Scope

**1.1.1** The requirements of this Section apply to bare wire-gas combinations and flux cored or flux coated wires with or without shielding gases to be used for automatic welding processes with multi-run technique (M) and two-run technique (T).

As regards preliminary information and requirements not expressly stated in this Section, reference may be made as far as applicable to the corresponding requirements of Sec 7.

### 1.2 Designation

**1.2.1** Wire gas combinations are divided, for the various strength levels, into the following grades as defined in Sec 1, [2.2.1]:

- 1, 2, 3, 4 for normal strength grades
- 1Y, 2Y, 3Y, 4Y, 5Y for high strength grades with specified minimum yield strength up to 355 N/mm<sup>2</sup>
- 2Y40, 3Y40, 4Y40, 5Y40 for high strength grades with specified minimum yield strength up to 390 N/mm<sup>2</sup>.

The prefix A is added to indicate automatic welding technique.

### 1.3 Approval tests

#### 1.3.1 General

Test samples for the approval are to be carried out using the welding technique for which approval is requested (multi-run M or two-run T technique).

In the case of the multi-run welding technique using wire diameters approved with the semiautomatic process, the tests are not to be repeated with the automatic process.

#### 1.3.2 Multi-run technique

Where approval for use with the multi-run technique (M) is requested, deposited weld metal and butt weld tests are to be carried out as indicated in [1.3.3] and [1.3.4], respectively.

#### 1.3.3 Deposited metal test

One deposited metal test is to be welded as shown in Sec 5, Fig 1; The base metal, the preparation of the test assembly welding, the checks and the number of tests required are to be as indicated in Sec 5, [1.2.3], except that the thickness of each layer is to be not less than 3 mm.

The wire diameter, type of current and welding parameters are to be in accordance with the recommendation of the Manufacturer.

The results of the tests are to comply with the requirements of Tab 1.

**Table 1 : Mechanical properties**

Grade	Longitudinal tensile test			Transverse tensile test	Charpy V-notch impact test	
	Yield stress $R_{eH}$ (N/mm <sup>2</sup> ) min.	Tensile strength $R_m$ (N/mm <sup>2</sup> )	Elong. $A_5$ (%) min.	Tensile strength $R_m$ (N/mm <sup>2</sup> ) min.	Test temp. (°C)	Minimum average energy (J)
1	305	400 - 560	22	400	+ 20	34
2					0	
3					- 20	
2Y	375	490 - 660	22	490	0	34
3Y					- 20	
4Y					- 40	
5Y					- 60	
2Y40	400	510 - 690	22	510	0	39
3Y40					- 20	
4Y40					- 40	
5Y40					- 60	

Figure 1 : Recommended edge preparation for two-run butt weld test assemblies

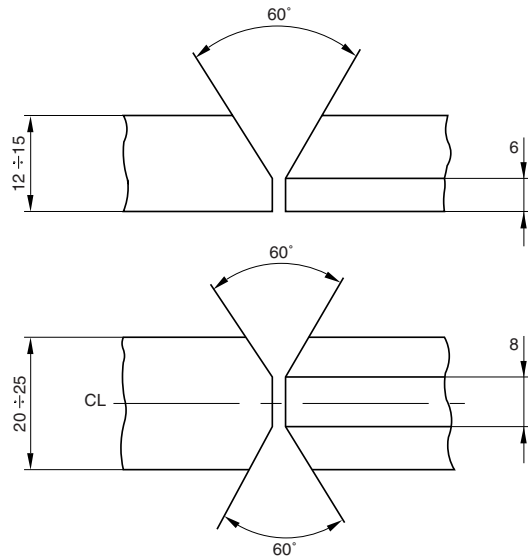

**1.3.4 Butt weld tests for multi-run technique**

One butt weld assembly is to be welded as shown in Sec 5, Fig 2 for each position to be approved; the base metal, the preparation of the test assembly welding, the checks and the number of test specimens required are to be as indicated in Sec 5, [1.2.4].

The diameter of the wire, type of current and welding parameters are to be in accordance with the recommendation of the Manufacturer.

The results of the tests are to comply with the requirements of Tab 1.

**1.3.5 Two-run technique**

Where approval for use with the two-run technique only (T) is requested, two butt weld test assemblies are to be carried out and no deposited metal test is requested.

The indications in Sec 5, [1.2.5] generally apply if not modified below, except that one test assembly is to be 12-15 mm thick and the other is to be 20 mm thick.

The bevel preparation of the test assemblies is to be as shown in Fig 1. Small deviations in the edge preparation may be allowed according to the Manufacturer’s recommendations.

If approval is requested for welding plates thicker than 20 mm, one assembly is to be prepared with plates 20 mm thick and the other with the maximum thickness for which the approval is requested. For assemblies using plates over 25 mm in thickness, the edge preparation used is to be reported for information.

The base metal, checks and number of test specimens required are to be as indicated in Sec 5, [1.2.5].

The diameter of the wire, type of current and welding parameters are to be in accordance with the recommendation of the Manufacturer.

The results of the tests are to comply with the requirements of Tab 1.

**1.4 Annual control tests**

**1.4.1 Multi-run technique**

The annual tests are to include at least the following:

- a) One deposited metal test assembly is to be welded in accordance with [1.3.3] with wires having minimum or maximum diameter, and the required tests (one longitudinal tensile test and three Charpy-V notch impact tests) are to be conducted.
- b) The chemical composition may be required to be checked under conditions corresponding to those of the approval tests.

**1.4.2 Two-run technique**

The annual tests are to include at least the following:

- a) One butt weld test assembly is to be welded in accordance with [1.3.5] with wires having minimum or maximum diameter, and the required tests (one transverse tensile test, three Charpy V-notch impact tests and two bend tests) are to be performed. One longitudinal tensile test is also required when the wire is approved for the two-run technique only.
- b) The chemical composition may be required to be checked under conditions corresponding to those of the approval tests.

### 1.4.3 Test requirements

The weld and test procedures, the type of current, the materials, the test results and the re-test procedures, where applicable, are regulated by the requirements relative to the approval tests.

For flux cored wire electrodes approved with symbol HH (or H10) or HHH (or H5), the hydrogen content may be required to be checked with the same procedure used in the approval tests.

# Section 9 Consumables for Welding C and C-Mn Steels with Electrode or Electroslag Process

## 1 Requirements

### 1.1 Scope

**1.1.1** The requirements of this Section apply to wire gas combinations and flux cored or flux coated wires for electrode (EG) and electroslag (ES) vertical welding with or without consumable nozzles of hull structural steels, of the corresponding grades of steel forgings and castings and of comparable steels intended for other structural applications.

#### 1.1.2 Type of wires

The wires are to be of the type recommended by the Manufacturer, obtained from original packages and of known chemical composition.

For electrode processes, wires having the chemical composition specified in Sec 7, Tab 1 may be used. Other wires of different chemical composition are to be submitted for consideration.

#### 1.1.3 Shielding gases

The requirements specified in Sec 7, [1.3.1] apply.

#### 1.1.4 Designation

The consumables are divided, for the various strength levels, into the following grades as defined in Sec 1, [2.2.1]:

- a) 1, 2, 3 for normal strength grades
- b) 2Y, 3Y, 4Y for high strength grades with specified minimum yield strength up to 355 N/mm<sup>2</sup>
- c) 2Y40, 3Y40, 4Y40 for high strength grades with specified minimum yield strength up to 390 N/mm<sup>2</sup>.

The prefix AV is added to the grade to indicate electrode or electroslag welding technique.

For high strength grades, the approval may be restricted for use with steels of specific composition. This applies, in particular, in relation to the content of grain refining elements, and if general approval is required, a Niobium treated steel is to be used for approval tests.

### 1.2 Information and documentation to be submitted

**1.2.1** The following information and supporting documentation are to be submitted together with the request for approval:

- a) commercial name, type of wire, limits of chemical composition in the case of bare wires
- b) type of process and grading under which the approval is requested
- c) type of shielding gas or gas mixture; commercial brand and Manufacturer, in the case of gas mixtures of special types
- d) type of flux, consumable insert when used
- e) type of current, range of current for which the approval is requested
- f) main characteristics of the welding equipment
- g) typical chemical composition of the deposited metal
- h) main operating characteristics and welding techniques, associated recommendations and limitations in general and in particular as regards edge preparation and welding parameters
- i) previous approvals already granted to the proposed consumables.

### 1.3 Approval tests

**1.3.1** Two butt weld test assemblies are to be prepared: one with plates 20/25 mm thick, the other with plates 35/40 mm thick or more.

The grade of steel to be used for each of these assemblies is to be selected according to the requirements given in Sec 5, Tab 3 for submerged arc welding.

The chemical composition of the plate, including the content of grain refining elements, is to be reported.

The welding conditions and the edge preparation adopted are to be in accordance with the recommendation of the Manufacturer and are to be reported.

The Manufacturer's maximum recommended gap between plates is to be used in making the test assemblies.

It is recommended that the welded assemblies be subjected to radiographic and or ultrasonic examination to ascertain the absence of defects prior to the preparation of test specimens.

The specimens shown in Fig 1 are to be taken for the following tests:

- a) two longitudinal tensile tests
- b) two transverse tensile tests
- c) two side bend tests
- d) two sets of three Charpy V-notch impact tests with notch located as shown in Fig 2 (i.e. one set with the notch located in the centre of the weld and one set with the notch located at 2 mm from the fusion line in the weld metal)
- e) two macro sections (in the middle of the sample and towards the end) and, if required, Vickers hardness checks.

The chemical analysis of the deposited weld metal is to be supplied by the Manufacturer and is to include the content of all significant alloying elements, if any.

**1.3.2** The results of tensile and impact tests on butt weld tests are to comply with the requirements specified in Sec 7, Tab 4, as appropriate.

Side bend tests Sec 1, [5.4.1] are to be performed on a mandrel having a diameter equal to three times the thickness of the specimen; the results are to comply with requirements in Sec 1, [5.3.1].

The Vickers hardness values, when verification is required, are to be  $HV \leq 270$ .

**Figure 1 : Butt weld test assembly for electrogas and electroslag welding**

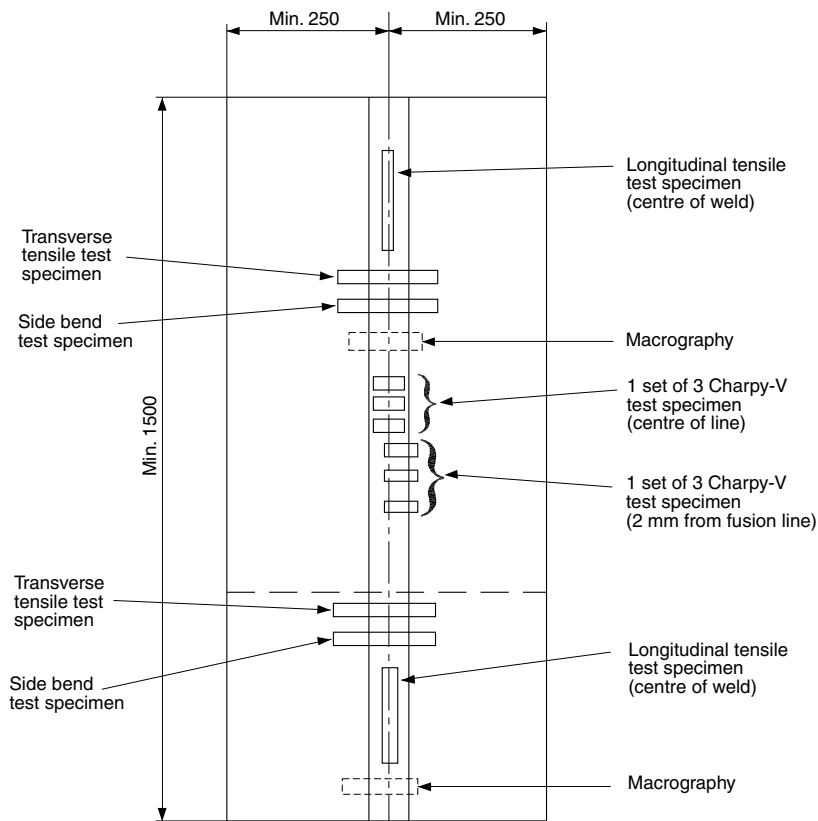

**Figure 2 : Position of Charpy V-notch impact test specimens**

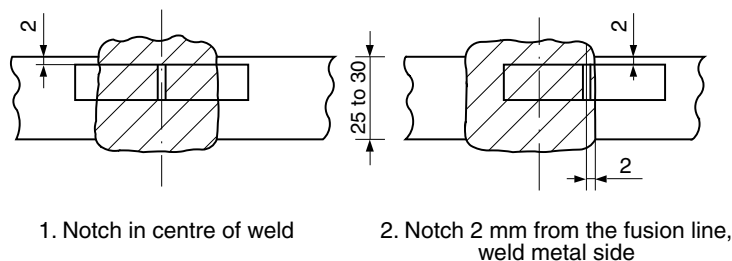

All the dimensions are in mm.

## **1.4 Annual control tests**

**1.4.1** The annual tests are to include at least a butt weld test assembly having thickness 20/25 mm. The non-destructive examinations required for the approval may be carried out on this sample and the following test specimens are to be taken:

- a) one longitudinal tensile test specimen
- b) one transverse tensile test specimen
- c) two side bend test specimens
- d) one set of three Charpy V-notch impact tests with the notch in the weld at 2 mm from the fusion line
- e) one set of three Charpy V-notch impact tests with the notch in the centre of the weld
- f) one section for macrographic examination.

The chemical composition may be required to be checked under conditions corresponding to those of the approval tests.

The weld and test procedures, the type of current, the materials, the test results and the re-test procedures, where applicable, are regulated by the requirements relative to the approval tests.

# Section 10 Consumables for Welding Extra High Strength Steels

## 1 Requirements

### 1.1 Scope

#### 1.1.1 General

The requirements of this Section apply to consumables used for weldable extra high strength steels with minimum specified yield strength from 420 N/mm<sup>2</sup> to 960 N/mm<sup>2</sup>.

Unless otherwise stated in this Section, the requirements relevant to the procedure, tests samples and welding conditions are generally to be in accordance with those of the previous Sections relevant to the approval of consumables for welding carbon and carbon-manganese steels, as follows:

- Sec 2: Covered electrodes for manual metal arc welding
- Sec 5: Flux-wire combination for submerged arc welding
- Sec 7: Wires and wire-gas combination for semi-automatic welding processes employing continuous wire
- Sec 8: Wires and wire-gas combination for automatic welding processes employing continuous wire.

#### 1.1.2 Designation

The designation is given by the appropriate grade as defined in Sec 1, [2.2.1] with the relevant prefix and/or suffix.

### 1.2 Approval tests

**1.2.1** The same samples are required as for C and C-Mn steel welding consumables approval.

The deposited metal, the butt weld and the fillet weld test samples are to be prepared using high strength steel having mechanical properties corresponding, as appropriate, to those of the welding consumable to be approved.

However, at the request of the Manufacturer, the all deposited metal samples may be allowed to be prepared using any C or C-Mn steels, provided that the bevels are duly buttered with the welding consumable to be approved.

**1.2.2** The checking of the chemical composition is to be carried out on shavings taken from the deposited material samples.

The checking of C, Mn, Si, S, P, Cr, Cu, Ni, Mo, N and of other alloying elements stated by the Manufacturer is to be carried out on all the samples.

**1.2.3** Welding consumables other than solid wire-gas combinations are to be subjected to a hydrogen test in accordance with Sec 2, [1.4] or recognised standards, as applicable.

The above consumables are to satisfy the hydrogen test requirement at least for the symbol HH (or H10) or HHH (or H5) for steels having specified yield strength levels, respectively, not higher or higher than 500 N/mm<sup>2</sup>.

**1.2.4** Unless special requests are made by the Manufacturer, the samples are not to be post-weld heat treated.

### 1.3 Test requirements

**1.3.1** The requirements specified under Sec 2, Sec 5 and Sec 7 for electrodes, submerged arc fluxes and wires for continuous wire processes, respectively, are to be met.

For chemical composition, the limits in percentage specified and guaranteed by the Manufacturer are to be satisfied.

For mechanical properties, the requirements specified in Tab 1 are to be met.

The results of the bend tests are to comply with the requirements in Sec 1, [5.3.1].

Where the required bending angle is not achieved, the specimen may be considered as fulfilling the requirements if the bending elongation  $L_0$  on a gauge length equal to  $L_s+t$  ( $L_0$  being the width of the weld and  $t$  the specimen thickness) fulfils the minimum elongation requirements specified for the deposited metal tensile test.

### 1.4 Annual control tests

**1.4.1** For the annual control tests, the samples and tests for checking the mechanical properties are to be carried out as required for C and C-Mn steel welding consumables.

For consumables grades 3Y89, 4Y89, 3Y96 and 4Y96, annual hydrogen test is required.



**Table 1 : Mechanical properties**

Grade		Tensile test on deposited metal			Tensile test on butt weld	Charpy V-notch impact test		Bend ratio and angle
		Yield stress $R_{eH}$ (N/mm <sup>2</sup> ) min.	Tensile strength $R_m$ (N/mm <sup>2</sup> )	Elong. $A_5$ (%) min.	Tensile strength $R_m$ (N/mm <sup>2</sup> ) min.	Test temp. (°C)	Minimum average energy (J)	D/ t <b>(1)</b> $\alpha \geq 120^\circ$
3	Y42	420	520 - 680	20	520	- 20	47	4
4						- 40		
5						- 60		
3	Y46	460	540 - 720	20	540	- 20	47	4
4						- 40		
5						- 60		
3	Y50	500	590 - 770	18	590	- 20	50	5
4						- 40		
5						- 60		
3	Y55	550	640 - 820	18	640	- 20	55	5
4						- 40		
5						- 60		
3	Y62	620	700 - 890	18	700	- 20	62	5
4						- 40		
5						- 60		
3	Y69	690	770 - 940	17	770	- 20	69	5
4						- 40		
5						- 60		
3	Y89	890	940 - 1100	14	940	- 20	69	6
4						- 40		
3	Y96	960	980 - 1150	13	980	- 20	69	7
4						- 40		

**(1)** D = mandrel diameter, t = specimen thickness

# Section 11 Consumables for Welding EH47 Steel and Crack Arrest Steel EH47CAS

## 1 Requirements

### 1.1 Scope

**1.1.1** The requirements of this Section apply to consumables used for weldable structural steels EH47 and EH47CAS.

Unless otherwise stated in this Section, the requirements relevant to the procedure, tests samples and welding conditions are generally to be in accordance with those of the previous Sections relevant to the approval of consumables for welding carbon and carbon-manganese steels, as follows:

- Sec 2: Covered electrodes for manual metal arc welding of C and C-Mn steels.
- Sec 7: Wires and wires-gas combination for semi-automatic welding processes employing continuous wire
- Sec 8: Wires and wires-gas combinations for automatic welding processes employing continuous wire
- Sec 9: Consumables for welding C and C-Mn steels with electrogas or electroslog process.

### 1.1.2 Designation

The designation 3Y47 is given with the relevant prefix and/or suffix.

### 1.2 Approval tests

**1.2.1** The same samples are required as for C and C-Mn steel welding consumables approval.

The deposited metal, the butt weld and the fillet weld test samples are to be prepared using high strength steel having mechanical properties corresponding, as appropriate, to those of the welding consumable to be approved.

However, at the request of the Manufacturer, the all deposited metal samples may be allowed to be prepared using any C or C-Mn steels, provided that the bevels are duly buttered with the welding consumable to be approved.

**1.2.2** The checking of the chemical composition is to be carried out on shavings taken from the deposited material samples.

The checking of C, Mn, Si, S, P, Cr, Cu, Ni, Mo, N and of other alloying elements stated by the Manufacturer is to be carried out on all the samples.

**1.2.3** Welding consumables other than solid wire-gas combination are to be subjected to a hydrogen test in accordance with Sec 2, [1.4] or recognised standards, as applicable.

The above consumables are to satisfy the hydrogen test requirement at least for the symbol HH (or H10) or HHH (or H5).

**1.2.4** Unless special requests are made by the Manufacturer, the samples are not to be post-weld heat treated.

### 1.3 Test requirements

**1.3.1** The requirements specified under Sec 2, Sec 7, Sec 8 and Sec 9 are to be met.

For chemical composition, the limits in percentage specified and guaranteed by the Manufacturer are to be satisfied.

For mechanical properties, the requirements specified in Tab 1 are to be met.

The results of the bend tests are to comply with the requirements in Sec 1, [5.3.1].

### 1.4 Annual control tests

**1.4.1** For the annual control tests, the samples and tests for checking the mechanical properties are to be carried out as required for C and C-Mn steel welding consumables.

**Table 1 : Mechanical properties**

Grade	Tensile test on deposited metal			Tensile test on butt weld	Charpy V-notch impact test		Bend ratio and angle
	Yield stress $R_{eH}$ (N/mm <sup>2</sup> )	Tensile strength $R_m$ (N/mm <sup>2</sup> )	Elong. $A_5$ (%) min.	Tensile strength $R_m$ (N/mm <sup>2</sup> ) min.	Test Temp. (°C)	Minimum average energy (J)	D/ t $\alpha \geq 120^\circ$
3Y47	460	570 - 720	19	570	-20	64	4

# Section 12 Consumables for Welding Mo and Cr-Mo Steels

## 1 Requirements

### 1.1 Scope

**1.1.1** The requirements of this Section apply to consumables used for welding Mo and Cr-Mo steels.

Unless otherwise stated in this Section, the requirements relevant to the procedure, tests samples and welding conditions are generally to be in accordance with those of the previous Sections relevant to the approval of consumables for welding carbon and carbon-manganese steels, as follows:

- Sec 2: Covered electrodes for manual metal arc welding
- Sec 5: Flux-wire combination for submerged arc welding
- Sec 7: Wires and wire-gas combination for semiautomatic welding processes employing continuous wire
- Sec 8: Wires and wire-gas combination for automatic welding processes employing continuous wire.

#### 1.1.2 Designation

Consumables are divided into the following grades, designated by a symbol indicating the nominal percentage Mo and Cr content of the deposited weld metal, as follows:

- M for Mo = 0,5
- C1M for Cr = 1,25 and Mo = 0,5
- C2M1 for Cr = 2,25 and Mo = 1

The relevant prefix and/or suffix are to be added to the grade.

### 1.2 Approval tests

**1.2.1** The same samples as for the C and C-Mn steel welding consumables approval are required.

The butt weld and the fillet weld test samples are to be prepared using the corresponding grade of Mo or Cr-Mo steels.

Instead of the above-mentioned Mo and Cr-Mo steels, at the request of the Manufacturer, grades 460 and 510 C-Mn steels for boilers and pressure vessels may be used.

**1.2.2** When the approval is required for two types of the same consumable, one with normal C content and the other with "low C" content, i.e. with C content not higher than 0,05%, and if the Manufacturer certifies that the only difference is the C content, for the approval of "low C" welding consumables the tests for checking the mechanical properties of the deposited material and the chemical composition only are to be carried out.

**1.2.3** With the exception of those for the hydrogen content checking, the test samples are to be welded in the preheating condition and are to be post-weld heat treated, as indicated in Tab 1, depending on the grade of the consumable.

**1.2.4** In the case of covered electrodes for manual welding, the checking of the chemical composition is to be carried out, as a rule, on samples of deposited metal described in Sec 1, [6].

Two samples are required with two different electrode diameters.

In the case of other types of welding consumables, the checking is to be carried out on shavings taken from the deposited metal samples.

The checking of C, Cr and Mo contents is to be carried out on all the samples and, additionally, the checking of Mn, Si, Cu, Ni, S and P contents and that of other alloy elements is to be carried out on one sample.

**Table 1 : Pre- and post-weld heating**

Consumable grade	M	C1M	C2M1
Preheating:			
Temperature (°C)	–	100 - 150	200 - 280
Post-weld heat treatment:			
Temperature T (°C)	620 ± 10	660 ± 10	710 ± 10
Soaking time at T (minutes)	30	30	60
Cooling rate down to 500°C (°C/h) in furnace (1)	150 - 250	150 - 250	100 - 200
(1) When 500°C is reached, the cooling may be continued either in the furnace or in still air.			

**1.2.5** Consumables may be submitted, at the Manufacturer’s request, to hydrogen tests and have the additional symbol H10 (or HH) or H5 (or HHH) added to the grade designation according to the hydrogen content.

**1.3 Test requirements**

**1.3.1** The requirements specified in Sec 2, Sec 5, Sec 7 and Sec 8 for electrodes, submerged arc fluxes and wires for continuous wire processes, respectively, are to be met.

For mechanical properties, the requirements specified in Tab 2 are to be met.

As a rule, transverse tensile tests on the welded joint are not required.

**1.3.2** For chemical composition, the limits in percentage of chemical composition specified in Tab 3 are to be met.

**Table 2 : Mechanical properties**

Grade	Tensile test on deposited metal (1)		Bend ratio and angle (2)
	Tensile strength $R_m$ (N/mm <sup>2</sup> )	Elong. $A_5$ (%) min.	D/ t $\alpha \geq 120^\circ$
M	490 - 640	20	3
C1M	490 - 690	20	3
C2M1	540 - 785	18	4

(1) The values of the minimum yield strength  $R_{eH}$  and reduction of area are also to be recorded, for information purposes.  
 (2) D = mandrel diameter, t = specimen thickness.

**Table 3 : Chemical composition**

Grade	Chemical composition (%)								
	C	Cr	Mo	Mn	Si max.	S max.	P max.	Cu max.	Ni max.
M	0,12 (1)	0,15	0,40 - 0,65						
C1M	0,12 (1)	1,0 - 1,5	0,40 - 0,65	0,50 - 0,90 (2)	0,60 (2)	0,040	0,040	0,20	0,30
C2M1	0,10 (1)	2,0 - 2,5	0,90 - 1,20						

(1) In the case of electrodes to be certified as “low carbon”, the carbon content is not to exceed 0,05%.  
 (2) The actual values of Mn and Si contents, guaranteed by the Manufacturer, within the limits specified in the Table, are to be stated at the time of the approval of single electrodes.

**1.4 Annual control tests**

**1.4.1** For the annual control tests, in addition to the samples and tests for checking the mechanical properties, as required for the consumables for welding C and C-Mn steels, the samples for checking the chemical composition, requested for the approval, are to be effected.

**1.4.2** For the “low C” welding consumables described in [1.2.2], the control tests are limited to one sample of deposited metal Sec 1, [6] and to the checking of the chemical composition.

# Section 13 Consumables for Welding Ni Steels for Low Temperature Applications

## 1 Requirements

### 1.1 Scope

**1.1.1** The requirements of this Section apply to consumables used for welding Ni steels for low temperature applications. Unless otherwise stated in this Section, the requirements relevant to the procedure, tests samples and welding conditions are generally to be in accordance with those in the previous Sections relevant to the approval of consumables for welding carbon and carbon-manganese steels, as follows:

- Sec 2: Covered electrodes for manual metal arc welding
- Sec 5: Flux-wire combination for submerged arc welding
- Sec 7: Wires and wire-gas combination for semi-automatic welding processes employing continuous wire
- Sec 8: Wires and wire-gas combination for automatic welding processes employing continuous wire.

#### 1.1.2 Designation

Consumables are divided into the following grades designated by a symbol indicating the type of nickel steel for which the consumables are intended, as follows:

- a) N15 for steels with Ni = 1,30 - 1,70 (%)
- b) N35 for steels with Ni = 3,25 - 3,75 (%)
- c) N50 for steels with Ni = 4,75 - 5,25 (%)
- d) N90 for steels with Ni = 8,50 - 10 (%)

The relevant prefix and/or suffix are to be added to the grade.

### 1.2 Approval tests

**1.2.1** The same samples as for the C and C-Mn steel welding consumables approval are required.

The butt weld and the fillet weld test samples are to be prepared using the corresponding grade of Ni steel.

Instead of the above-mentioned Ni steel, at the request of the Manufacturer, steels with lower Ni content but having suitable mechanical properties for the tests to be carried out may be used. In such case, if deemed necessary by the Manufacturer, the bevels may be duly buttered with the welding consumable to be approved.

In the case of use of plates with buttered bevels and where the mechanical properties of the welding consumable are significantly lower than those of the base material, longitudinal instead of transverse specimens may be allowed to be taken for face and root bend tests. In this case the length of the sample is to be such as to allow the taking of these specimens.

**1.2.2** In the case of covered electrodes for manual welding, the checking of the chemical composition is to be carried out, as a rule, on samples of deposited metal described in Sec 1, [6].

Two samples are required with two different electrode diameters.

In the case of other types of welding consumables, the checking is to be carried out on shavings taken from the deposited metal samples.

The checking of C, Ni, Mn and Si contents is to be carried out on all the samples and, additionally, the checking of Cu, Cr, S, P and other alloy elements is to be carried out on one sample.

**1.2.3** Consumables may be submitted, at the Manufacturer's request, to hydrogen tests and have the additional symbol H10 (or HH) or H5 (or HHH) added to the grade designation according to the hydrogen content.

**1.2.4** Unless special requests are made by the Manufacturer, the samples are not to be post-weld heat treated.

### 1.3 Tests requirements

**1.3.1** The requirements specified in Sec 2, Sec 5, Sec 7, Sec 8 for electrodes, submerged arc fluxes and wires for continuous wire processes, respectively, are to be met.

For mechanical properties, the requirements specified in Tab 1 are to be met.

As a rule, transverse tensile tests on the welded joint are not required.

**1.3.2** For chemical composition, the limits in percentage of chemical composition specified and guaranteed by the Manufacturer are to be met.

**1.4 Annual control tests**

**1.4.1** For the annual control tests, in addition to the samples and tests for checking the mechanical properties as required for the consumables for welding C and C-Mn steels, the samples for checking the chemical composition, requested for the approval, are to be effected.

**Table 1 : Mechanical properties**

Grade	Tensile test on deposited metal			Tensile test on butt weld	Charpy V-notch impact test		Bend ratio and angle
	Yield stress $R_{eH}$ (N/mm <sup>2</sup> ) min.	Tensile strength $R_m$ (N/mm <sup>2</sup> ) min.	Elong. $A_5$ (%) min.	Tensile strength $R_m$ (N/mm <sup>2</sup> ) min.	Test temp. (°C)	Minimum average energy (J)	D / t <b>(1)</b> $\alpha \geq 120^\circ$
N 15	355	470	22	490	- 80	34	3
N 35	355	470	22	490	- 100	34	3
N 50	380	520	22	540	- 120	34	4
N 90	420	670	22	690	- 196	34	4

**(1)** D = mandrel diameter, t = specimen thickness

## Section 14

# Consumables for Welding Cr-Ni Austenitic and Austenitic-Ferritic Stainless Steels

## 1 Requirements

### 1.1 Scope

#### 1.1.1 General

The requirements of this Section apply to consumables used for welding Cr-Ni austenitic and austenitic-ferritic stainless steels.

Unless otherwise stated in this Section, the requirements relevant to the procedure, tests samples and welding conditions are, in general, to be in accordance with those in the previous Sections relevant to the approval of consumables for welding carbon and carbon-manganese steels, as follows:

- Sec 2: Covered electrodes for manual metal arc welding
- Sec 5: Flux-wire combination for submerged arc welding
- Sec 7: Wires and wire-gas combination for semi-automatic welding processes employing continuous wire
- Sec 8: Wires and wire-gas combination for automatic welding processes employing continuous wire.

#### 1.1.2 Designation

Consumables intended for welding austenitic steels are divided into the following grades designated by a symbol corresponding to the AWS designation of the weld metal, as follows:

308, 308L, 316, 316L, 316LN, 317, 317L, 309, 309L, 309Mo, 310, 310Mo, 347.

The additional symbol BT is added when the requirements on impact test energy are satisfied at the temperature of -196°C.

Consumables intended for welding austenitic-ferritic steels are designated by a symbol indicating the nominal percentage content of Cr and Ni in the deposited metal (e.g. 2205 means 22% Cr and 5% Ni).

The relevant prefix and/or suffix are to be added to the grade.

### 1.2 Approval tests

**1.2.1** The same samples as for the C and C-Mn steel welding consumables approval are required, with the exception of samples for hydrogen content checking.

The all deposited metal, the butt weld and the fillet weld test samples are to be prepared using the corresponding grade of stainless steel.

However, at the request of the Manufacturer, the all deposited metal may be allowed to be prepared using C and C-Mn steels, provided that the bevels are duly buttered with the welding consumable to be approved.

**1.2.2** When the approval is required for two types of the same welding consumable, one with normal C content and one with "low C" content, for the approval of "low C" welding consumables the tests for checking the mechanical properties of the deposited material and the chemical composition only are to be carried out.

**1.2.3** In the case of covered electrodes for manual welding, the checking of the chemical composition is to be carried out, as a rule, on samples of deposited metal and described in Sec 1, [6].

One sample is required for each electrode diameter to be approved.

In the case of other types of welding consumables, the checking is to be carried out on shavings taken from the deposited metal samples.

The checking of C, Cr, Ni contents is to be carried out on all the samples, in addition to Mo, Nb and N contents where such elements characterise the welding consumable being tested. For only one of the diameters tested, the chemical analysis of the remaining elements listed in Tab 2 is also to be carried out.

**1.2.4** For consumables for welding austenitic-ferritic steels, the ratio ferrite/austenite is also to be determined in the all deposited material.

**1.2.5** Corrosion tests according to ASTM A262 Practice E, ASTM G48 Method A or equivalent recognised standards may be required, on a case-by-case basis, for austenitic and duplex stainless steel consumables.

**1.2.6** Unless special requests are made by the Manufacturer, the samples are not to be post-weld heat treated.

1.3 Tests requirements

1.3.1 The requirements specified in Sec 2, Sec 5, Sec 7, Sec 8 for electrodes, submerged arc fluxes and wires for continuous wire processes, respectively, are to be met.

For mechanical properties, the requirements specified in Tab 1 are to be met.

For consumables intended for welding Cr-Ni austenitic steels for which the approval is required with the additional symbol BT, the requirements on adsorbed energy in the impact test specified in the table are to be satisfied at the temperature of -196°C.

1.3.2 For chemical composition of welding consumables intended for Cr-Ni austenitic steels, the limits in percentage specified in Tab 2 are to be satisfied.

For chemical composition of welding consumables intended for austenitic-ferritic steels, the limits in percentage specified and guaranteed by the Manufacturer are to be satisfied.

Table 1 : Required mechanical properties

Grade	Tensile test on deposited metal			Tensile test on butt weld	Charpy V-notch impact test		Bend ratio and angle
	Yield stress $R_{p0.2}$ (N/mm <sup>2</sup> ) min.	Tensile strength $R_m$ (N/mm <sup>2</sup> ) min.	Elong. $A_5$ (%) min.	Tensile strength $R_m$ (N/mm <sup>2</sup> ) min.	Test temp. (°C)	Minimum average energy (J)	D / t (1) $\alpha \geq 120^\circ$
Austenitic							
308	290	540	25	515	- 20 (2)	27	3
308L	275	490	25	485			
316	290	540	25	515			
316L	275	490	25	485			
316LN	290	540	25	515			
317	290	540	25	515			
317L	275	490	25	515			
309	290	540	22	515			
309L	275	490	22	515			
309Mo	290	540	22	515			
310	290	540	25	515			
310Mo	290	540	25	515			
347	290	540	25	515			
Austenitic-ferritic							
2205	480	680	25	680	- 20	27	
(1) D = mandrel diameter, t = specimen thickness							
(2) The impact test temperature is -20°C, except when the additional symbol BT is required, in which case the test is to be carried out at -196°C.							

Table 2 : Chemical composition

Grade	Chemical composition (%)					
	C	Mn	Cr	Ni	Mo	Others
308	≤ 0,08	0,5 - 2,5	18 - 21	8 - 11	≤ 0,75	
308L	≤ 0,04	0,5 - 2,5	18 - 21	8 - 11	≤ 0,75	
316	≤ 0,08	0,5 - 2,5	17 - 20	11 - 14	2 - 3	
316L	≤ 0,04	0,5 - 2,5	17 - 20	11 - 14	2 - 3	
316LN	≤ 0,04	0,5 - 2,5	17 - 20	10 - 14	2 - 3	0,15 ≤ N ≤ 0,20
317	≤ 0,08	0,5 - 2,5	17 - 21	11 - 14	2,5 - 4	
317L	≤ 0,04	0,5 - 2,5	17 - 21	11 - 14	2,5 - 4	
309	≤ 0,15	0,5 - 2,5	22 - 26	11 - 15	≤ 0,75	
309L	≤ 0,04	0,5 - 2,5	22 - 26	11 - 15	≤ 0,75	
309Mo	≤ 0,12	0,5 - 2,5	22 - 26	11 - 15	2 - 3	
310	0,08 - 0,20	1,0 - 2,5	25 - 28	20 - 22,5	≤ 0,75	
310Mo	≤ 0,12	1,0 - 2,5	25 - 28	20 - 22	2 - 3	
347	≤ 0,08	0,5 - 2,5	18 - 21	9 - 11	≤ 0,75	8xC ≤ Nb+Ta ≤ 1



## **1.4 Annual control tests**

**1.4.1** For the annual control tests, in addition to the samples and tests for checking the mechanical properties as required for the consumables for welding C and C-Mn steels, the samples for checking the chemical composition are also to be effected.

**1.4.2** For the "low C" welding consumables described in [1.2.2], the control tests are limited to one sample of deposited metal and to the checking of the chemical composition.

## Section 15

## Consumables for Welding Aluminium Alloys

## 1 Requirements

## 1.1 Scope

**1.1.1** The requirements of this Section apply to wire or rod-gas combinations to be used for welding the Al-Mg and Al-Si aluminium alloys specified in Chapter 9.

Unless otherwise stated in this Section, the requirements relevant to the procedure, tests samples and welding conditions are generally to be in accordance with those in Sec 7 and Sec 8 relevant to the approval of consumables for welding with continuous wire process.

The welding consumables preferably to be used for the aluminium alloys concerned are divided into two categories, as follows:

- a) W = wire electrode and wire gas combination for metal-arc inert gas welding (MIG), tungsten inert gas welding (TIG) or plasma arc welding (PAW)
- b) R = rod-gas combinations for tungsten inert gas welding (TIG) or plasma arc welding (PAW).

Note 1: For aluminium welding consumables, there is no unique relationship between the products (wire electrode, wire or rod) and the welding process used (TIG, MIG, PAW). Therefore the wire electrodes, wire or rods, in combination with the relevant shielding gas, will be approved on the basis of the above products form W and R and may be used, as appropriate, for one or more of the above processes.

## 1.1.2 Grading

The consumables are graded as specified in Tab 1 in accordance with the alloy type and strength level of the base materials used for the approval tests.

**Table 1 : Consumable grades and base materials for the approval tests**

Consumable quality grade (symbol)	Base material for the tests	
	Alloy designation	
	Numerical	Chemical symbol
RA/ WA	5754	AlMg3
RB/ WB	5086	AlMg4
RC/ WC	5083	AlMg4,5Mn0,7
	5383	AlMg4,5Mn0,9
	5456	AlMg5
	5059	–
RD/ WD	6005A	AlSiMg(A)
	6061	AlMg1SiCu
	6082	AlSi1MgMn

**Note 1:** Approval on higher strength AlMg base materials covers also the lower strength AlMg grades and their combination with AlSi grades.

**Table 2 : Composition of shielding gases**

Group symbol	Gas composition in volume (%) (1)	
	Argon	Helium
I-1	100	–
I-2	–	100
I-3 (2)	Balance	> 0 to 33
I-4 (2)	Balance	> 33 to 66
I-5 (2)	Balance	> 66 to 95
S	Special gas composition to be specified	

(1) Gases of other chemical composition (mixed gases) may be considered as special gases and are to be covered by separate tests  
(2) Gas mixture to be used for the tests is as follows:

- Group I-3: approx. 15% He
- Group I-4: approx. 50% He
- Group I-5: approx. 75% He

### 1.1.3 Shielding gases

For the purpose of the approval, the type of gas and mixture of gas are grouped as indicated in Tab 2.

Unless otherwise required for specific applications, gas mixtures in the same group are considered equivalent for approval purposes. Special gases in terms of composition or purity are to be designated with the group "S".

## 1.2 Approval tests

### 1.2.1 Deposited weld metal

For the testing of the chemical composition of the deposited weld metal, a test piece according to Fig 1 is to be prepared. The size depends on the type of the welding consumable (and on the process used) and is to give a sufficient amount of pure metal for chemical analysis. The base metal is to be compatible with the weld metal in respect of chemical composition.

The chemical analysis of the deposited weld metal is to be supplied by the Manufacturer and is to include the content of all the significant elements. The results of the analysis are not to exceed the limit values specified in the standards or by the Manufacturer.

**Figure 1 : Deposited weld metal test assembly**

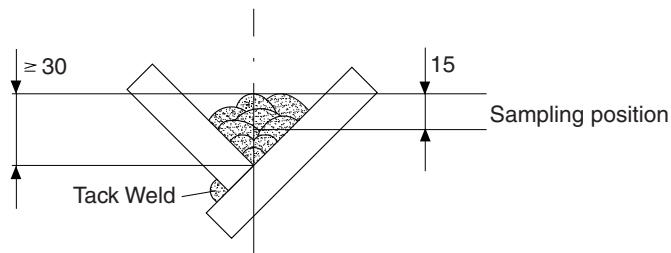

### 1.2.2 Butt weld test assembly

Butt weld test assemblies, in the material specified in Tab 3 and having thickness 10-12 mm, are to be prepared for each welding position (downhand, horizontal, vertical-upwards and overhead) for which the consumable is recommended by the Manufacturer (see Fig 3); see also [1.2.3]. Subject to the agreement of the Society, consumables satisfying the requirements for the downhand and vertical-upwards position will also be considered as complying with the requirements for the horizontal position.

### 1.2.3 Additional butt weld test assembly

One additional test assembly, having 20-25 mm, is to be welded in the downhand position (see Fig 2).

### 1.2.4 Post-weld condition

On completion of welding, the assemblies are to be allowed to cool naturally to ambient temperature. Welded test assemblies and test specimens are not to be subjected to any heat treatment. Grade D assemblies are to be allowed to artificially age for a minimum period of 72 hours from the completion of the welding and a maximum of one week, before testing is carried out.

## 1.3 Test requirements

**1.3.1** It is recommended that the weld assemblies are subjected to radiographic examination to ascertain if there are any defects in the welds prior to the preparation of the test specimens.

**1.3.2** The test specimens are to be taken from the welded assemblies as shown in Fig 3 and Fig 2. For each assembly they are to include:

- one specimen for macrographic examination
- two transverse tensile specimens
- two face bend specimens, and
- two root bend specimens.

The macro specimen is to be examined for defects such as cracks, lack of fusion, cavities, inclusions and pores. Cracks, lack of fusion or incomplete penetration are not allowed.

The transverse tensile test results are to meet the requirements stated in Tab 3.

The bend test parameters are stated in Tab 3. After bending, no crack or other open defect exceeding 3 mm in length is to be seen on the outer surface. Defects which may appear at the corners of a bend specimen are not to be considered.

It is recommended that the bending test is performed with the "wrap around bending method" instead of the "free bend test" in order to obtain uniform bending of the specimen (see Fig 4).

Figure 2 : Additional butt weld test assembly in downhand position

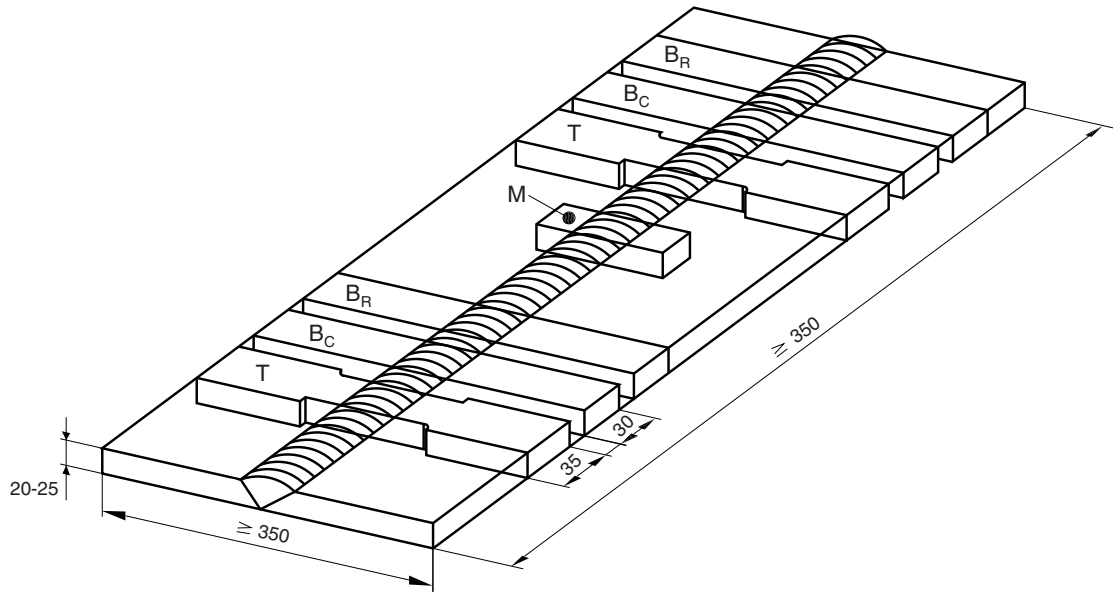

T = flat tensile test specimen; B<sub>C</sub> = face bend test specimen; B<sub>R</sub> = root bend test specimen; M = macrographic section

Note 1: Edge preparation is to be single V with an angle of 70°.

Note 2: Back sealing runs are allowed.

Figure 3 : Butt weld test assembly for positional welding

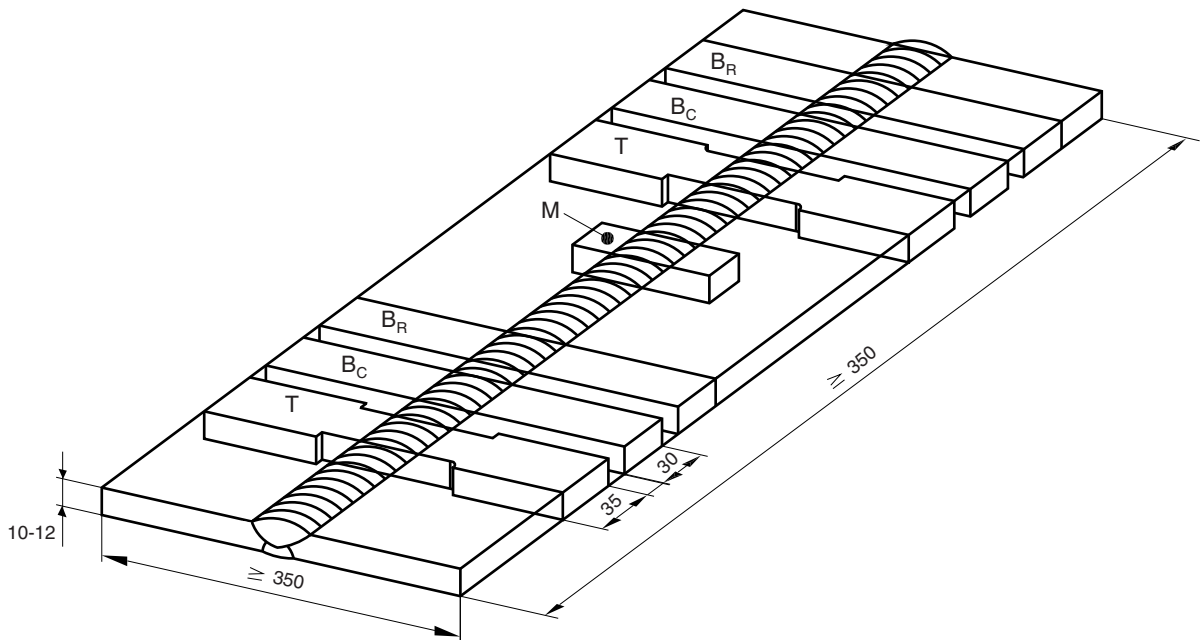

T = flat tensile test specimen; B<sub>C</sub> = face bend test specimen; B<sub>R</sub> = root bend test specimen; M = macrographic section

Note 1: Edge preparation is to be single V or double V with an angle of 70°.

Note 2: Back sealing runs are allowed in single V weld assemblies.

Note 3: In case of double V assembly, both sides are to be welded in the same welding positions.

**Table 3 : Requirements for the transverse tensile and bend tests**

Grade	Base material used for the test	Tensile strength $R_m$ (N/mm <sup>2</sup> ) min.	Former diameter	Bending angle (1) (°) min.
RA/WA	5754	190	3 t	180
RB/WB	5086	240	6 t	
RC/WC	5083	275	6 t	
	5383 or 5456	290	6 t	
	5059	330	6 t	
RD/WD	6061, 6005A or 6082	170	6 t	

(1) During testing, the test specimen is not to reveal any one single flaw greater than 3 mm in any direction. Flaws appearing at the corners of a test specimen is to be ignored in the evaluation unless there is evidence that they result from lack of fusion.

**Figure 4 : Wrap around bend test**

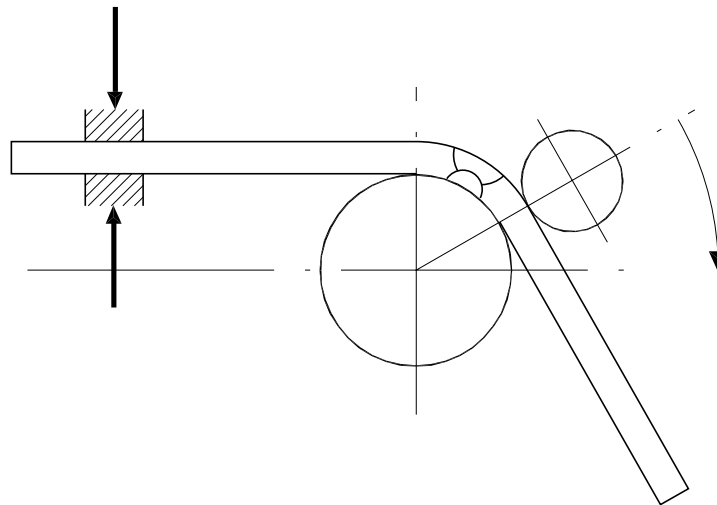

The fixed edge of the test specimen is to be clamped to avoid sliding. The whole welded zone (weld and heat affected zone), in the case of transverse bending, is to be entirely positioned in the bent zone.

**1.4 Annual control tests**

**1.4.1** For the annual control tests, the deposited weld metal test assembly as per Fig 1 and the butt weld test assembly as per Fig 3 are to be welded.

The tests required in [1.2.1] and [1.3] are to be performed.

## CHAPTER 12 WELDING

---

Section 1	General Requirements
Section 2	General Requirements for Qualification of Welding Procedures
Section 3	Welding Procedures for Steel Ship Hull and Welded Structures
Section 4	Welding Procedures for other Ship Applications
Section 5	Welding Procedures for Aluminium Alloys
Section 6	Welding Procedures for Offshore Structures and Equipment
Section 7	Welding Procedures for CO <sub>2</sub> Laser
Section 8	Welding Procedures for Friction Stir Welding

# Section 1 General Requirements

## 1 Scope

### 1.1 General

**1.1.1** This Section specifies the general requirements for fabrication by welding, while the other Sections specify the requirements for approval welding procedures.

**1.1.2** The requirements are essentially intended for the welding of weldable steels and aluminium alloy grades covered by the applicable Sections of these Rules.

**1.1.3** Different materials, applications and procedures, as well as other standards and specifications, may be considered by the Society on a case-by-case basis.

## 2 Fabrication by welding

### 2.1 General

**2.1.1** Fabrication by welding is to be carried out in compliance with the applicable Society Rules and according to normal good practice, general or specific to the individual processes, to the Surveyor's satisfaction; in particular the conditions stated at the time of approval and authorisation for the use of individual processes are to be complied with.

The welded structures, the relevant details and the size of welds are to comply with the applicable requirements; any other requirements indicated on the approved plans or specified during survey of construction are also to be complied with.

### 2.2 Approval

#### 2.2.1 Plans

The constructional plans are to be submitted for approval when required by the Rules or in individual cases and are to contain the necessary data relevant to the fabrication by welding of the structures and items represented. In particular, material types, welding details, welding processes and weld size are to be indicated; any details not represented in the plans are, in any case, to comply with the applicable requirements.

#### 2.2.2 Welding procedures and consumables

Welding to be used in hull construction, machinery, pressure systems and equipment subject to survey by the Society, is to be carried out with approved welding consumables and welding procedures according to these Rules.

Requirements regarding the use of the various grades of approved consumables are indicated in the parts of the Rules concerning the application or at the time of plan approval.

#### 2.2.3 Welders and welding operators

Welders for manual welding and for semiautomatic welding processes are to be properly trained and are to be certified by the Society, as required in the individual applications, unless otherwise agreed.

Welders are to be certified according to the procedures given in Rule Note NR476 Approval Testing of Welders. Welders engaged in friction stir welding for aluminium alloys structures are to be qualified in accordance with ISO 25239-3.

The certification is to be in due course of validity.

Personnel manning the automatic welding machines are to be competent and sufficiently trained.

#### 2.2.4 Welding supervision

Welders are to be supervised and assisted, in the course of the welding operation, by an adequate number of competent supervisors, such as to ensure efficient control of the welding production.

Certification of the welding inspectors is not compulsory and is left to the discretion of the Manufacturer, except in particular cases where it may be required by the Society.

**2.2.5** Reference is made to Ch 1, Sec 1, [3.6] for the non-destructive examination and qualification of personnel.

## **2.3 Type of joints, edge preparations and size**

### **2.3.1 General**

The types of joints and the edge preparations are to be appropriate to the welding processes adopted, to the particular structures and to the stresses to which they are subjected, to the satisfaction of the Society.

Size and design are to be in accordance with requirements given in the Rules relevant to the applications, approved plans, and specific provisions stipulated for hulls and for pressure systems and machinery.

## **2.4 Welding execution and control**

**2.4.1** Edge preparation, surface conditions, assembly pre- and post- weld heating, welding sequences and inspections of the welded structures are to be in accordance with good practice and, where applicable, are to comply with the requirements given in the Rules relevant to the applications.



# Section 2 General Requirements for Qualification of Welding Procedures

## 1 Requirements

### 1.1 Scope

**1.1.1** This Section specifies the general requirements for the qualification and approval of welding procedures.

The requirements relevant to materials not covered herein are agreed on a case-by-case basis following, as far as applicable, the criteria specified in this Chapter.

### 1.2 Welding procedure

#### 1.2.1 Welding processes

Qualification tests are, as a rule, required for the manual or semiautomatic or automatic processes indicated below together with their relevant numbering according to ISO 4063:2009:

- Manual metal arc welding: 111
- Submerged Arc Welding with wire electrode (SAW): 12
- Flux-Cored wire metal Arc Welding without gas shield (FCAW): 114
- Metal arc Inert Gas welding (MIG welding): 131
- Metal arc Active Gas welding (MAG welding): 135
- Flux-Cored wire metal Arc Welding with active gas shield: 136
- Flux-Cored wire metal Arc Welding with inert gas shield: 132
- Tungsten Inert Gas arc welding (TIG welding): 141
- Plasma Arc Welding (PAW): 15.

#### 1.2.2 Welding consumables

Consumables approved in accordance with the requirements of Chapter 11 are to be used within the limits of their approval.

When non-approved welding consumables are used, the requirements relevant to the qualification of the welding procedures are established on a case-by-case basis and tests on a deposited metal sample are required.

Requirements relevant to the grade of welding consumables to be used are given in the relevant Society's Rules.

#### 1.2.3 Preliminary welding procedure specification

A welding procedure specification is to be prepared by the Manufacturer or Shipyard which intends to perform the qualification tests. This document is also referred to as a preliminary welding procedure specification (pWPS) and is to be submitted to the Society for review prior to the tests.

This pWPS may be modified and amended during the procedure tests as deemed necessary however it shall define all relevant variables as mentioned in the welding procedure specification, see [1.2.4].

In case that the test pieces welded according to the pWPS show unacceptable results the pWPS shall be adjusted by the Shipyard or Manufacturer. The new pWPS shall be prepared and the test pieces welded in accordance with the new pWPS.

In general, the qualification tests shall reflect fabrication conditions in respect to welding equipment, inside or outside fabrication, weld preparation, preheating and any post-weld heat treatment. It shall be the manufacturer's responsibility to establish and document whether a procedure is suitable for the particular application.

The test pieces are to be chosen so as to cover all the production welds in accordance with the range of approval for the parameters as defined in the Sections of this Chapter.

#### 1.2.4 Approval of welding procedure specification

The qualification tests when required, welding of test pieces according to the proposed pWPS and testing of test specimens, are to be witnessed by the Surveyor.

Upon satisfactory completion of the tests, the Society may approve the pWPS as a welding procedure specification.

In its final version, the welding procedure specification (WPS) is to include all the parameters characterising the welding process; in particular, as applicable:

- a) type of welding process and equipment, as appropriate
- b) type of joint, preparation and backing material, if any
- c) base metal and thickness range
- d) filler metal
- e) welding position
- f) minimum preheat, minimum and maximum interpass temperature
- g) post-weld heat treatment if applicable
- h) shielding gas as applicable
- i) welding parameters
- j) other information relevant to the welding techniques as applicable.

The actual parameters used for welding the approval test pieces and the results of the inspections and tests carried out are to be recorded in the welding procedure qualification record (WPQR) also referred to as welding procedure approval record (WPAR). The WPQR is generally prepared by the shipyard or welding shops and endorsed by the attending Surveyor.

### 1.2.5 Inspections

Inspections and control tests may be periodically and randomly required as deemed necessary by the Society and are to yield satisfactory results in order to maintain the validity of the approval.

The results of any suitable control performed during production may be accepted, to the Surveyor's satisfaction.

### 1.2.6 Responsibilities of the users

The qualification tests are intended to verify that a manufacturer is adequately qualified to perform welding operations using a particular procedure.

Irrespective of the inspections carried out by the Surveyor, the user is responsible for the use of the approved procedures, within the limits of the range qualified and the conditions stated at the time of the approval.

Compliance with the above is essential for the validity of the approval.

# Section 3 Welding Procedures for Steel Ship Hull and Welded Structures

## 1 General requirements

### 1.1 Approval

1.1.1 Reference is made to general requirements as per Sec 2

## 2 Welding procedure qualification tests for C and C-Mn steels for ship hull and other welded structures in general

### 2.1 Plates butt weld with full penetration

#### 2.1.1 Assembly of test pieces

Preparation and welding are to be in accordance with the pWPS and under the general condition of production welding which it represents.

If tack welds and / or start and stop points are a condition of the weld process they are to be fused into the joint and are to be included in the test pieces.

The test assembly is to be of a size sufficient to ensure a reasonable heat distribution and is to have the minimum following dimensions (see Fig 1):

- manual or semiautomatic welding:  
length  $L = 6t$ , minimum 350 mm  
width  $W$  with  $W/2 = 3t$ , minimum 150 mm.
- automatic welding:  
length  $L \geq 1000$  mm  
width  $W$  with  $W/2 = 4t$ , minimum 200 mm.

In the case of steel plates impact tested in the longitudinal direction (CVN-L), the butt weld of the test piece is perpendicular to the rolling direction of the two plates.

In the case of steel plates impact tested in the transversal direction (CVN-T), the butt weld of the test piece is parallel to the rolling direction of the two plates.

#### 2.1.2 Examinations and tests

Non-destructive examinations and destructive tests required according to Tab 1 are to be carried out, while the location of the test specimens is to be in accordance with Fig 2.

**Figure 1 : Test assembly for plate butt weld**

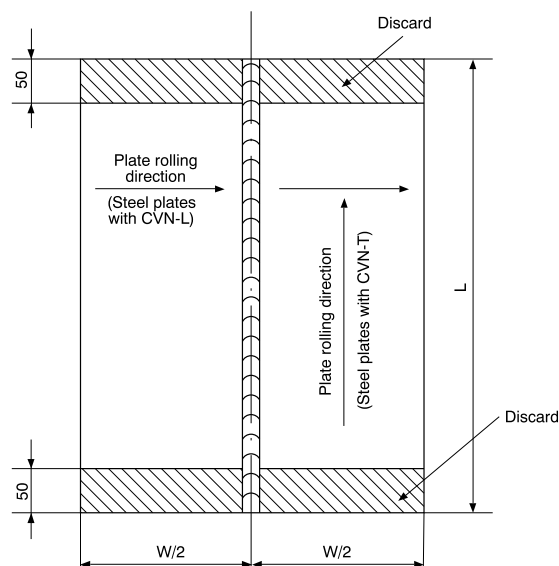

Figure 2 : Location of test specimens

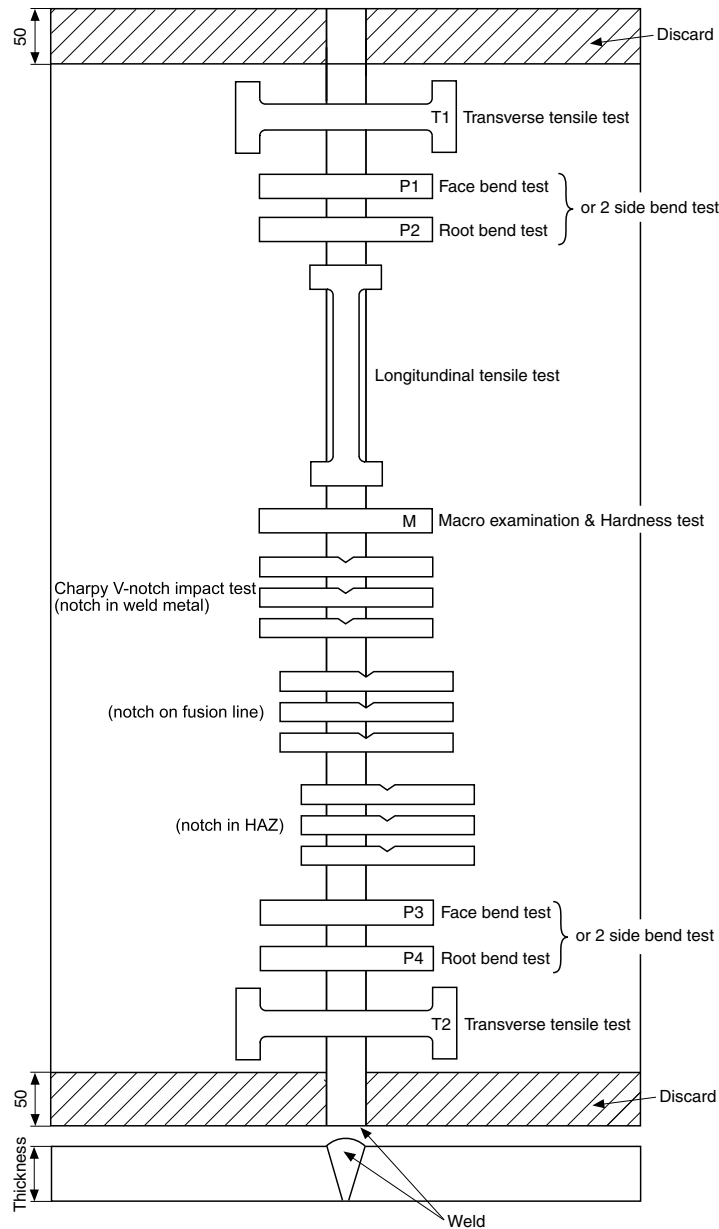

Table 1 : Examinations and tests

Type of examination or test	Extent of examination or test
Visual examination	100%
Surface crack detection (1)	100%
Radiographic or ultrasonic examination	100%
Transverse tensile test	2 specimens
Transverse bend tests (2)	2 root and 2 face specimens
Charpy V-notch impact tests (3)	3 sets
Macro examination	on 1 section
Hardness test (4)	on 1 section
Longitudinal tensile test (5)	1 specimen

(1) Dye penetrant according to ISO 3452 (or equivalent accepted standard) or magnetic particle testing; for non-magnetic materials, dye penetrant only.  
 (2) For  $t \geq 12$  mm, the face and root bends are preferably to be replaced by 4 side bends.  
 (3) 3 sets each of 3 specimens as per [2.1.7].  
 (4) Only required for high strength steels with minimum specified yield strength equal to or greater than 355 N/mm<sup>2</sup>.  
 (5) Required only when the use of non-approved filler metal has been accepted (see Sec 2, [1.2.2]).

**2.1.3 Non-destructive examinations**

Non-destructive examinations are to be carried out after any required or specified post-weld heat treatment and prior to the cutting of test specimens.

Imperfections detected by visual or non-destructive testing shall be assessed in accordance with ISO 5817 class B, except for the following imperfections for which the level C applies:

- excess weld metal or convexity,
- excess throat thickness, and
- excess of penetration.

**2.1.4 Transverse tensile tests**

Specimens for transverse tensile tests are to be in accordance with Ch 2, Sec 2, [1.1.11].

The tensile strength recorded for each specimen is to be not less than the minimum required for the parent metal; the location of the fracture is to be reported.

When butt welds are made between plates of different grades, the tensile strength to be obtained on the welded assembly is to be in accordance with the requirement of the grade having lower strength.

**2.1.5 Tensile tests on cylindrical specimens**

When required (see Tab 1), a round tensile specimen is to be cut along the weld axis to the dimension given in Ch 2, Sec 2, Fig 3, in the all weld metal.

Where the size of the deposited metal is too small, a 6 mm diameter specimen may be taken or a deposited weld metal test is to be carried out in accordance with the requirements of Chapter 11.

The tensile properties recorded (yield stress  $R_{eH}$ , tensile strength  $R_m$  and elongation  $A_5$ ) are to be not less than the minimum required for the approval of the appropriate grade of consumables.

When more than one welding process or type of consumable has been used to make the test weld, test specimens are to be removed from the area of the weld where each was used with the exception of those processes or consumables used to make the first weld run or root deposit.

**2.1.6 Bend tests**

Transverse root bend, face bend and side bend specimens are to be machined to the dimensions given in Ch 2, Sec 3, [1.1].

For dissimilar or heterogeneous butt-joints, one longitudinal bend test may be used instead of transverse bend tests.

The test specimens are to be bent on a mandrel having a diameter equal to 4 times the thickness of the specimen; the bending angle is to be 180°.

After testing, the test specimens are not to reveal any open defect, in any direction, greater than 3 mm. Defects appearing at the corners of the test specimen during testing are to be investigated case-by-case.

When butt welds are made between plates of different grades, face and root longitudinal bend test specimens may be used instead of the transverse bend test specimens.

**2.1.7 Impact tests**

Dimensions and testing of Charpy V-notch impact test specimens are to be in accordance with Chapter 2.

Charpy V-notch impact test specimens in accordance with Chapter 2 are to be sampled from 1 to 2 mm below the surface of the parent material, transverse to the weld and on the side containing the last run.

The Charpy V-notch specimens are located in the butt-welded joint as indicated in Fig 3, Fig 4, Fig 5 and Fig 6, and the V-notch is to be cut perpendicular to the surface of the weld.

The test temperature and absorbed energy are to be in accordance with Tab 2.

When butt welds are made between different steel grades / types, the test specimens are to be taken from the side of the joint with steel of lower toughness level. Temperature and absorbed energy results are to be in accordance with the minimum value required for the steel of lower toughness level.

Where more than one welding process or consumable has been used to make the test weld, impact test specimens are to be removed from the respective areas where each was employed. This should not apply to the process or consumables used solely to make the first weld run or root deposit.

When cast or forged material with specified impact values is to be welded, test temperature and absorbed energy are to be in accordance with the requirements of the base material.

Unless otherwise agreed with the Society, the test temperature and absorbed energy of steels not covered by these requirements are to be in accordance with the specification of the parent metal.

**2.1.8 Macro examinations**

The test specimens are to be prepared and etched on one side to clearly reveal the weld metal, fusion line, the heat affected zone (HAZ) and about 10mm of unaffected parent metal.

The examination shall reveal a regular weld profile, through fusion between adjacent layers of weld and base metal and the absence of defects such as cracks, lack of fusion etc.

Table 2 : Impact test requirements for butt joints ( $t \leq 50$  mm)

Grade of steel	Testing temperature (°C)	Value of minimum average absorbed energy (J) (1)		
		For manually or semi-automatically welded joints		For automatically welded joints
		Downhand, Horizontal, Overhead	Vertical upward, Vertical downward	
A (2)	20	47	34	34
B (2), D	0			
E	-20			
AH32, AH36	20			
DH32, DH36	0			
EH32, EH36	-20			
FH32, FH36	-40			
AH40	20	39	39	39
DH40	0			
EH40	-20			
FH40	-40			

(1) For thickness above 50 mm, impact test requirements are to be agreed by the Society.  
 (2) For grade A and grade B steels, average absorbed energy in fusion line and heat affected zone is to be minimum 27 J.

Figure 3 : Location of V-notch for normal heat input  $\leq 50$  kJ/cm ( $t \leq 50$  mm)

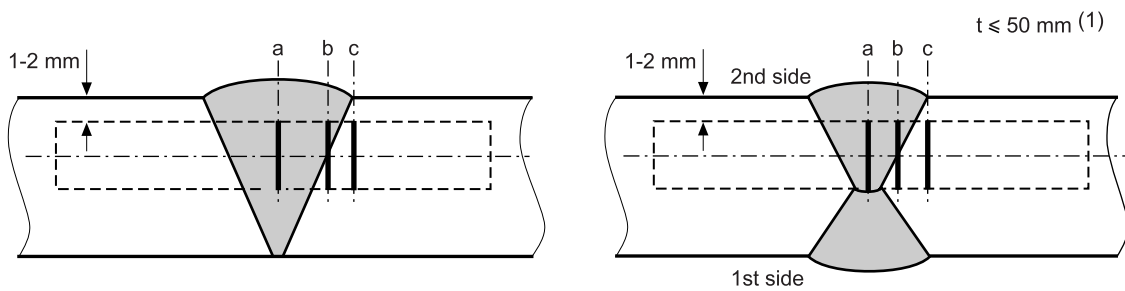

Note 1: For one side pass welding over 20 mm, is to be added on root side 3KV with notch located on (a).

3KV with notch located on:

- a : Centre of weld "WM"
- b : On fusion line "FL"
- c : In HAZ, 2 mm from fusion line

Figure 4 : Location of V-notch for normal heat input  $\leq 50$  kJ/cm ( $t > 50$  mm)

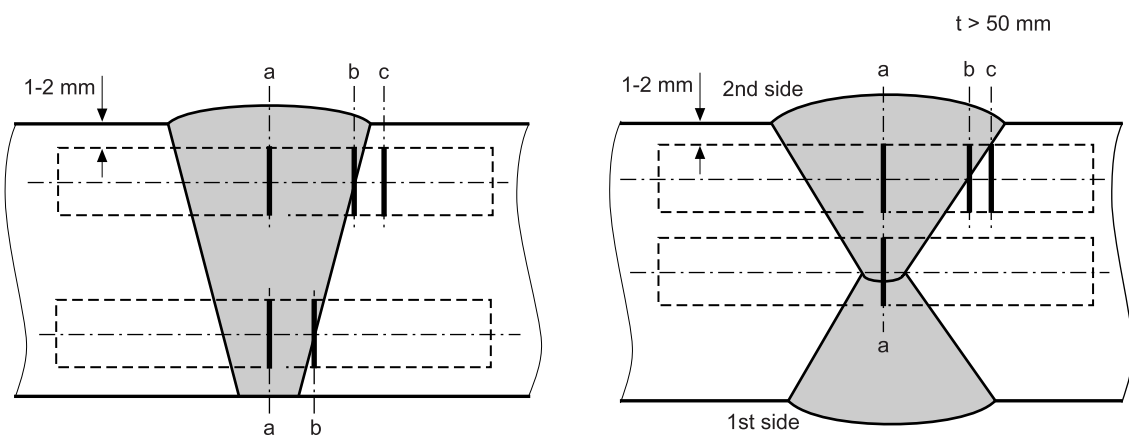

3KV with notch located on:

- a : Centre of weld "WM"
- b : On fusion line "FL"
- c : In HAZ, 2 mm from fusion line

Figure 5 : Location of V-notch for high heat input > 50 kJ/cm ( $t \leq 50$  mm)

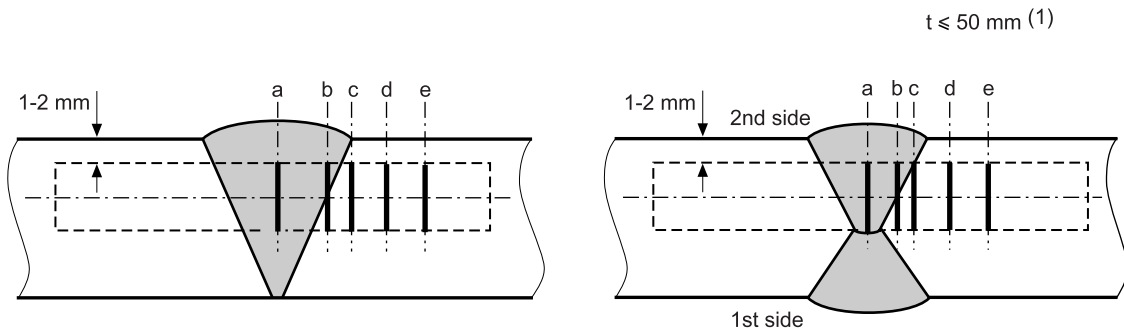

Note 1: For one side pass welding over 20 mm, is to be added on root side 3KV with notch located on (a), (b) and (c).

3KV with notch located on:

- a : Centre of weld "WM"
- b : On fusion line "FL"
- c : In HAZ, 2 mm from fusion line
- d : In HAZ, 5 mm from fusion line
- e : In HAZ, 10 mm from fusion line in case of heat input > 200 kJ/cm

Figure 6 : Location of V-notch for high heat input > 50 kJ/cm ( $t > 50$  mm)

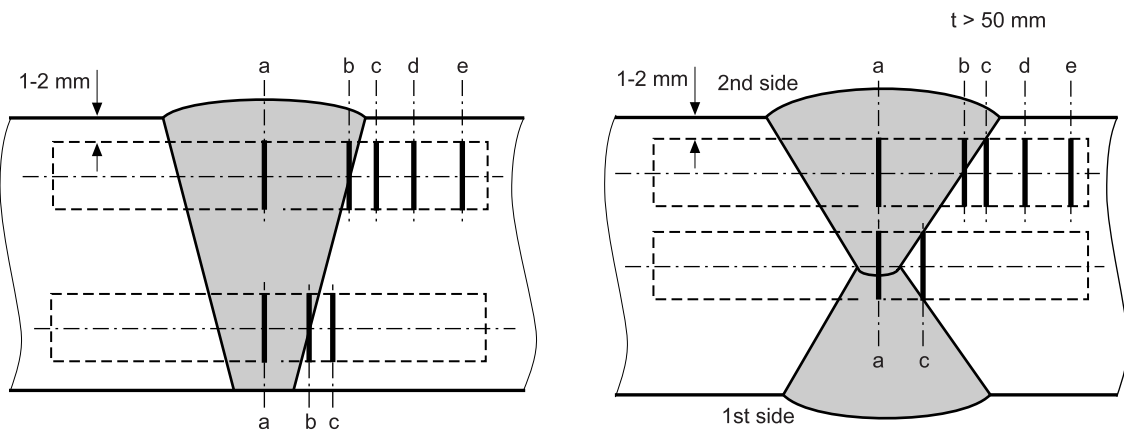

3KV with notch located on:

- a : Centre of weld "WM"
- b : On fusion line "FL"
- c : In HAZ, 2 mm from fusion line
- d : In HAZ, 5 mm from fusion line
- e : In HAZ, 10 mm from fusion line in case of heat input > 200 kJ/cm

### 2.1.9 Hardness tests

Hardness testing is required for steels with minimum specified yield strength equal to or greater than 355N/mm<sup>2</sup>. Unless otherwise agreed, the Vickers method HV10 is to be used.

The indentations are to be made in the weld, heat affected zones, and the parent metals measuring and recording the hardness values. Two rows of indentations are to be carried out in accordance with Fig 7.

For each row of indentations, there is to be a minimum of 3 individual indentations in the weld, the heat affected zones (both sides) and the parent metals (both sides).

The distance between the indentations may vary from 0,5 to 2 mm depending on the zone tested.

Typical example of hardness indentations are given in Fig 7.

The results of hardness tests are not to exceed 350 HV for steels with a specified minimum yield strength less than or equal to 420 N/mm<sup>2</sup>.

Figure 7 : Examples of hardness indentations

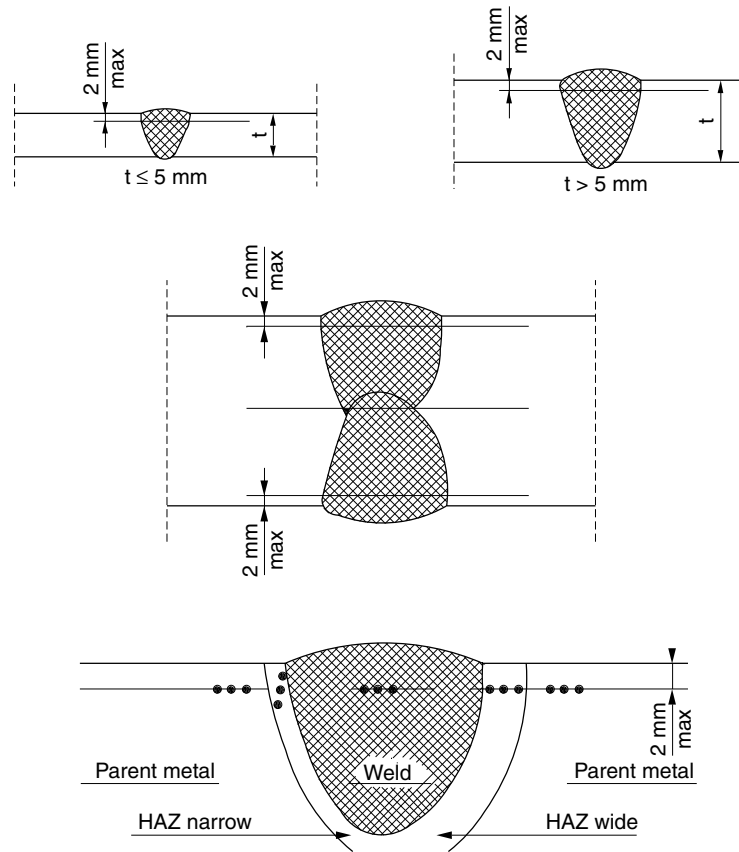

## 2.2 T butt joints in plates

### 2.2.1 General

Where this type of joints is predominant in production, qualification tests are to be performed on T butt joint assembly in addition to the equivalent qualification on butt joint.

The same principle applies when changes occur in the geometry of the bevel which may significantly affect the penetration or fusion.

### 2.2.2 Assembly and welding

Preparation and welding are to be in accordance with the pWPS and under the general condition of production welding which it represents.

If tack welds are a condition of the weld process, they are to be fused into the joint and are to be included in the test pieces.

The test assembly is to be of a size sufficient to ensure a reasonable heat distribution and is to have the minimum following dimensions (reference can be made to Fig 9):

- a) manual or semiautomatic welding:
  - length  $L = 6t$ , min. 350 mm
  - width  $W = 3t$ , min. 150 mm
- b) automatic welding:
  - length  $L = \text{min. } 1000 \text{ mm}$
  - width  $W = 3t$ , min. 150 mm.

### 2.2.3 Examinations and tests

Non-destructive examinations and destructive tests are required according to Tab 3; a discard of 50 mm from both edges is permitted.

### 2.2.4 Non-destructive examination

Reference is made to [2.1.3].

### 2.2.5 Tensile tests on cylindrical specimens

Reference is made to [2.1.5].

### 2.2.6 Macro examination

Reference is made to [2.1.8].



Table 3 : Examinations and tests for T butt joints in plates

Type of examination or test	Extent of examination or test
Visual examination	100%
Surface crack detection (1)	100%
Ultrasonic examination (4)	100%
Macro examination	on 1 section
Hardness test (2)	on 1 section
Longitudinal tensile test (3)	1 specimen

(1) Dye penetrant according to ISO 3452 (or equivalent accepted standard) or magnetic particle testing; for non-magnetic materials, dye penetrant only.  
 (2) Only required for high strength steels with minimum specified yield strength equal to or greater than 355 N/mm<sup>2</sup>.  
 (3) Required for thickness above 50 mm or when the use of non-approved filler metal has been accepted (see Sec 2, [1.2.2]).  
 (4) Applicable to full penetration weld or to verify the extent of penetration in partial penetration welds

2.2.7 Hardness test

Hardness testing is required for steels with minimum specified yield strength equal to or greater than 355 N/mm<sup>2</sup>. Unless otherwise agreed, the Vickers method HV10 is to be used.

The indentations are to be made in the weld, heat affected zones, and the parent metals measuring and recording the hardness values.

Rows of indentations are to be carried out in accordance with Fig 8.

For each row of indentations, there is to be a minimum of 3 individual indentations in the weld, the heat affected zones (both sides) and the parent metals (both sides).

The results of hardness tests are not to exceed 350 HV for steels with a specified minimum yield strength less than or equal to 420 N/mm<sup>2</sup>.

Figure 8 : Hardness indentations

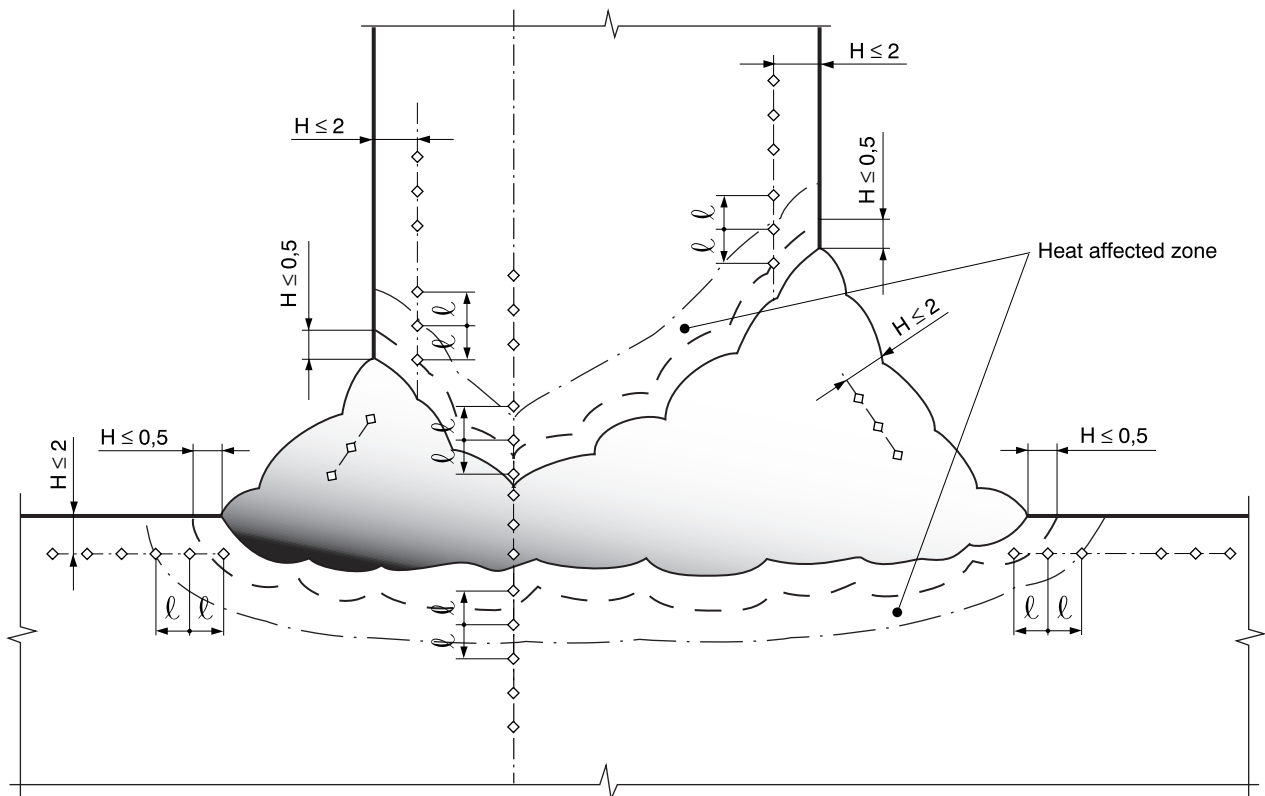

with H, dimension in mm.

**2.3 Plates fillet weld**

**2.3.1 Assembly and welding**

Preparation and welding are to be in accordance with the pWPS and under the general condition of production welding which it represents.

If tack welds are a condition of the weld process they are to be fused into the joint and are to be included in the test pieces.

The test assembly is welded on one side only. For single pass manual and semi-automatic welding, a stop/restart is to be included in the test length and its position is to be clearly marked for subsequent examination.

The test assembly is to be of a size sufficient to ensure a reasonable heat distribution and is to have the minimum following dimensions (see Fig 9):

- a) manual or semiautomatic welding:
  - length  $L = 6 t$ , minimum 350 mm
  - width  $W = 3 t$ , minimum 150 mm
- b) automatic welding:
  - length  $L \geq 1000$  mm
  - width  $W = 3 t$ , minimum 150 mm.

**2.3.2 Examinations and tests**

Non-destructive examinations and destructive tests required according to Tab 4; a discard of 50 mm from both edges is permitted.

**Figure 9 : T fillet joint on plates**

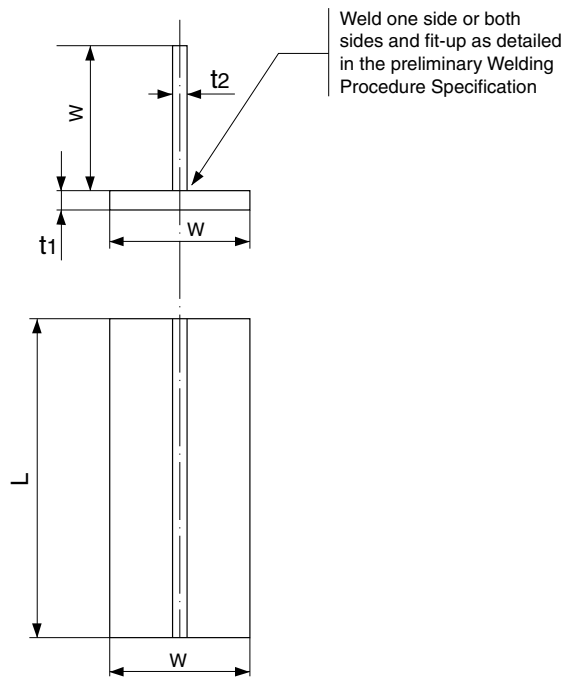

**Table 4 : Examinations and tests**

Type of examination or test	Extent of examination or test
Visual examination	100%
Surface crack detection (1)	100%
Macro examination (2)	2 sections
Hardness test (3)	on 1 section
Fracture test	1 test
(1) Dye penetrant according to ISO 3452 (or equivalent accepted standard) or magnetic particle testing; for non-magnetic materials, dye penetrant only. (2) One of the macro sections is to be taken at the position of the stop/restart; see [2.3.1]. (3) Only required for high strength steels having: $R_{eH} \geq 355 \text{ N/mm}^2$	

**2.3.3 Visual examination and surface crack detection**

Non-destructive examinations are to be carried out after any required or specified post-weld heat treatment and prior to the cutting of test specimens.

Imperfections detected are to be assessed in accordance with [2.1.3].

**2.3.4 Macro examination**

The test specimen is to be prepared and etched on one side to clearly reveal the weld metal, fusion line, root penetration, the heat affected zone and about 10mm of unaffected base material.

The examination shall reveal a regular weld profile, through fusion between adjacent layers of weld and base metal and the absence of defects such as cracks, lack of fusion etc.

The dimensions of leg size, throat and penetration are to be reported.

**2.3.5 Fracture test**

The fracture test is to be performed by folding the upright plate onto the through plate. Evaluation is to be concentrated on cracks, porosity and pores, inclusions, lack of fusion and incomplete penetration. Imperfections that are detected shall be assessed in accordance with ISO 5817 Class B.

**2.3.6 Hardness test**

Hardness testing is required for steels with minimum specified yield strength equal to or greater than 355N/mm<sup>2</sup>. Unless otherwise agreed, the Vickers method HV10 is to be used.

The indentations are to be made in the weld, heat affected zones, and the parent metals measuring and recording the hardness values. Two rows of indentations are to be carried out in accordance with Fig 10.

For each row of indentations, there is to be a minimum of 3 individual indentations in the weld, the heat affected zones (both sides) and the parent metals (both sides).

The results of hardness tests are not to exceed 350 HV for steels with a specified minimum yield strength less than or equal to 420 N/mm<sup>2</sup>.

**Figure 10 : Macro and hardness indentations**

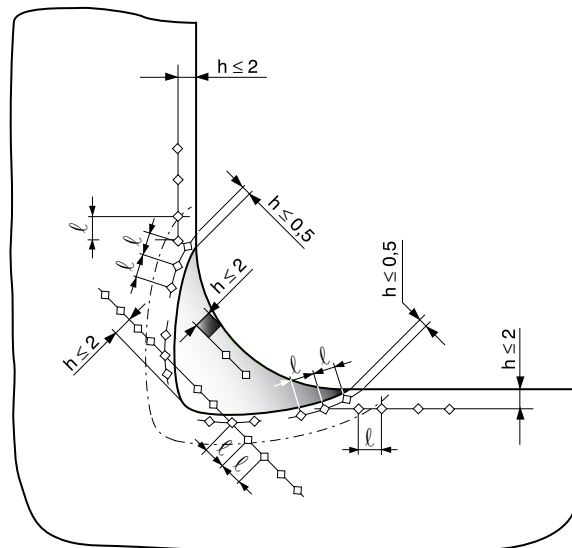

**2.4 Pipes butt weld with full penetration**

**2.4.1 Assembly and welding**

Preparation and welding are to be in accordance with the pWPS and under the general condition of production welding which it represents.

If tack welds are a condition of the weld process they are to be fused into the joint and are to be included in the test pieces.

The test assembly is to be in accordance with Fig 11.

**2.4.2 Examinations and tests**

Non-destructive examinations and destructive tests required according to Tab 1. The location of the test specimens is to be in accordance with Fig 12.

**2.4.3 Results**

The results are to comply with the requirements for plate butt weld in [2.1].

**Figure 11 : Pipe weld test assembly**

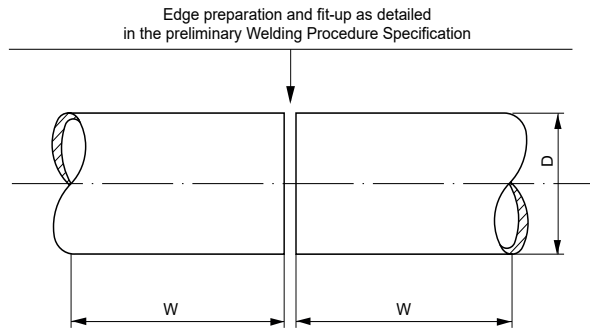

W = 150 mm minimum; D = outside diameter

**Figure 12 : Location of test specimens**

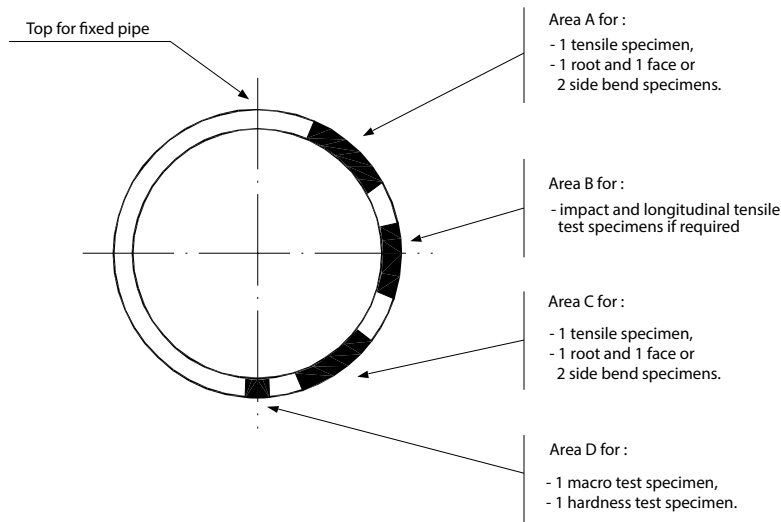

**2.5 Re-testing**

**2.5.1** If the test piece fails to comply with any of the requirements for visual or non-destructive testing, one further test piece is to be welded and subjected to the same examination.

If this additional test piece does not comply with the relevant requirements, the pWPS is to be regarded as not capable of complying with the requirements without modification.

**2.5.2** If any test specimens fails to comply with the relevant requirements for destructive testing due to weld imperfection only, two further test specimens shall be obtained for each one that failed. These specimens can be taken from the same test piece if there is sufficient material available or from a new test piece, and is to be subjected to the same test. If either of these additional test specimens does not comply with the relevant requirements, the pWPS is to be regarded as not capable of complying with the requirements without modification.

**2.5.3** If a tensile test specimen fails to meet the requirements, the re-testing is to be in accordance with Ch 2, Sec 2, [1.3].

**2.5.4** If there is a single hardness value above the maximum values allowed, additional hardness tests shall be carried out (on the reverse of the specimen or after sufficient grinding of the tested surface). None of the additional hardness values is to exceed the maximum hardness values required.

**2.5.5** The re-testing of Charpy V-notch impact test specimens are to be carried out in accordance with Ch 2, Sec 4, [1.4].

**2.5.6** Where there is not sufficient material remaining in the test piece to provide the additional test specimens, a further assembly shall be welded using the same procedure to provide the additional specimens.

**2.6 Range of approval**

**2.6.1 General**

The approval of a WPS obtained by a yard or Manufacturer is valid for welding in workshops under the same technical and quality management, to the Society's satisfaction.

The welding procedure is to be used within the range of the parameters indicated below; changes outside the range specified of one or more of these parameters require a new qualification test.

**2.6.2 Parent metal**

For hull structural steel grades A to FH40 as defined in Ch 3, Sec 2, the following applies:

- a) For each strength level, welding procedures are considered applicable to the same and lower toughness grades as that tested
- b) For each toughness grade, welding procedures are considered applicable to the same and two lower strength levels as that tested
- c) For applying the above a) and b) to high heat input processes above 50kJ/cm, e.g. the two-run technique with either submerged arc or gas shielded metal arc welding, electroslag and electrogas welding, welding procedure is applicable that toughness grade tested and one strength level below.

Where steels used for construction are supplied from different delivery conditions from those tested, the Society may require additional tests.

For weldable C and C-Mn hull steel forgings as defined in Ch 5, Sec 2, the following applies:

- a) Welding procedures are considered applicable to the same and lower strength level as that tested
- b) Qualification tests on quenched and tempered hull structural steel forgings do not qualify other delivery condition and vice-versa.

For weldable C and C-Mn hull steel castings as defined in Ch 6, Sec 2, the following applies:

- a) Welding procedures are considered applicable to the same and lower strength level as that tested
- b) Qualification tests on quenched and tempered hull structural steel castings do not qualify other delivery condition and vice-versa.

**2.6.3 Thickness**

The qualification of a WPS carried out on a welded assembly of thickness t is valid for the thickness range given in Tab 5.

In addition to the requirements of Tab 5, the range of approval for fillet welds shall be as follows:

- a) Single pass fillet welds; for throat thickness a, the range of approval is "0,75 a" to "1,5 a"
- b) Multipass fillet welds; for throat thickness a, the range of approval is as for multipass butt welds (i.e. a = t).

For the vertical-down welding, the test piece thickness t is always taken as the upper limit of the range of application.

For unequal plate thickness of butt welds the lesser thickness is the ruling dimension.

Notwithstanding the above, the approval of maximum base material thickness for any technique is restricted to the test assembly thickness if three of the hardness values in the heat affected zone are found to be within 25 HV of the maximum permitted, as stated in [2.1.9], in [2.2.7] and [2.3.6].

**2.6.4 Pipe diameter**

Qualification tests on an assembly of pipes of diameter D is valid for diameters in the range given in Tab 6.

**2.6.5 Welding position**

Standard positions are given in Fig 13 for plates and pipes.

Approval for a test made in any position is restricted to that position.

To qualify all positions, test assemblies are to be welded for highest and lowest heat input position and all applicable tests are to be made on those assemblies.

For plates butt welds with full penetration, the highest heat input position is normally the vertical upwards position and the lowest heat input position is normally the horizontal position.

**Table 5 : Approved thickness range**

Thickness t of test piece (mm) (1)	Range of approval	
	Butt and T-joint welds with single run or single run from both sides	Butt and T-joint welds with multi-run and fillet welds (2)
3 < t ≤ 12	0,7 t to 1,1 t	3 mm to 2 t
12 < t ≤ 100	0,7 t to 1,1 t (3)	0,5 t to 2 t (max.150)
(1) For multi process procedures, the recorded thickness contribution of each process is to be used as a basis for the range of approval for the individual welding process. (2) For fillet welds, the range of approval is to be applied to both parent materials. (3) For high heat input process over 50 kJ/cm, the upper limit of range of approval is to be 1,0 t.		

**Table 6 : Approved diameter range**

Diameter of the test piece (mm)	Range of approval (1)
D ≤ 25	0,5 D to 2 D
D > 25	≥ 0,5 D (25 mm min.)
(1) Qualification for plates also covers pipes with outside diameter > 500 mm.	

Figure 13 : Welding positions according to ISO Standard

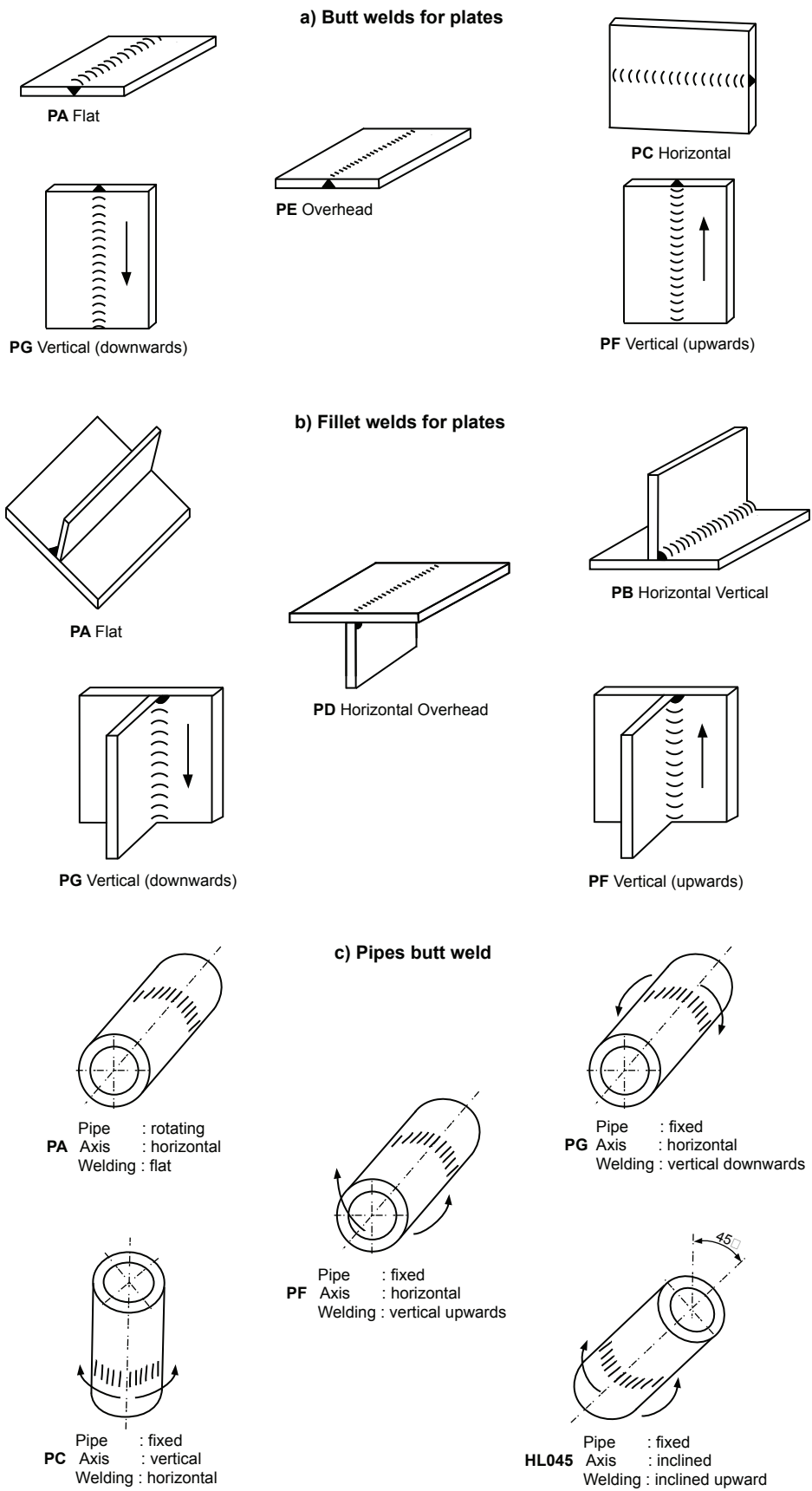

**2.6.6 Welding process**

The approval is only valid for the welding process(es) used in the qualification tests. It is not permitted to change from a multi-run to a single run.

For multi-process procedures the welding procedure approval may be carried out with separate qualification tests for each welding process. It is also accepted to make the qualification test as a multi-process procedure test. The approval of such a test is only valid for the process sequence carried out during the multi-process procedure test.

For the manual metal arc welding process (111) and semi-automatic welding process with flux cored wire without shielding gas (114), the approval obtained is valid for the diameter of the electrode used in the welding procedure test plus or minus one electrode diameter size for each run, except for the root run of the one side welded assembly without backing strip, for which no size change is allowed.

For the gas metal arc welding processes (131, 135, 136), the approval obtained for face and/or back shielding gas is restricted to the type of gas (nominal composition) used during the procedure test. The approval is restricted to the wire system used in the approval test (e.g. single wire or multi-wire) and, in the case of automatic welding, to the relevant welding technique.

For the submerged arc processes (12), the approval obtained is restricted to the wire system used in the approval test (e.g. single wire or multi-wire) and relevant welding technique (T, M, U). Change in the flux trade mark requires new welding procedure approval tests.

**2.6.7 Welding consumables**

Except high heat input process (over 50KJ/cm), welding consumables tested cover other approved welding consumables having the same grade mark including all suffixes specified in Chapter 11 with that tested.

Change in the trade name of filler metal requires new welding procedure approval tests when Charpy V-notch impact tests are required at temperature strictly below -20°C.

**2.6.8 Heat input**

The upper limit of heat input approved is 25% greater than that used in welding the test piece or 50 kJ/cm whichever is smaller, except that the upper limit is 10% greater than that for high heat input processes over 50 kJ/cm.

The lower limit of heat input approved is 25% lower than that used in welding the test piece.

**2.6.9 Preheat and interpass temperature**

The minimum preheat temperature is not to be less than that used in the qualification test.

The minimum interpass temperature is not to be less than the specified preheat temperature.

The maximum interpass temperature is not to be higher than that used in the qualification test.

**2.6.10 Post-weld heat treatment**

The heat treatment used in the qualification test is to be maintained during manufacture. Holding time may be adjusted as a function of thickness.

**2.6.11 Type of joint**

The range of approval depending on type of welded joint for test assembly is given in Tab 7.

New qualification tests may be required by the Surveyor when changes occur in the geometry of the bevel which may significantly affect the penetration or fusion.

**Table 7 : Range of approval for type of joint**

Type of welded joint for test assembly			Range of approval				Fillet welds on plate and pipe
			Butt welds and T butt joints for plates with full or partial penetration				
			Welded from one side		Welded from both sides		
			with backing	no backing	with gouging	no gouging	
Full penetration butt weld for plates	One side (1)	with backing	◇	–	x	–	x
		no backing	x	◇	x	x	x
	Both sides	with gouging	–	–	◇	–	x
		no gouging	–	–	x	◇	x
Fillet weld for plates	–	–	–	–	–	◇	

**Note 1:**

◇ indicates the type of assembly of qualification test.

x indicates on the same line as the symbol ◇ those welds for which the WPS is also approved.

– indicates on the same line as the symbol ◇ those welds for which the WPS is not approved.

(1) Butt welds on a plate welded from one side approve butt welds on pipes having diameter > 500 mm within the limitations of the Table.

### 3 Welding procedures for extra high strength steels

#### 3.1 Requirements

3.1.1 Test pieces, tests and requirements for the approval of the welding procedures are to be as specified in [2.1] to [2.6], unless otherwise specified in this Article.

3.1.2 The bend specimens are to be bent on a mandrel having a diameter equal to 5 times the specimen thickness in the case of steel types 420 and 460 and equal to 6 times the specimen thickness in the case of steel types 500, 550, 620 and 690.

3.1.3 The results from the hardness test is not to exceed 420 HV10 for steels with a specified minimum yield strength from 420 N/mm<sup>2</sup> to 690 N/mm<sup>2</sup>.

3.1.4 For the range of approval of parent metal the following applies:

- a) for each strength level, welding procedures are considered applicable to the same and lower toughness grades as that tested
- b) for each toughness grade, welding procedures are considered applicable to the same and one lower strength levels as that tested
- c) qualification tests with quenched and tempered steels do not qualify thermo-mechanically rolled steels and vice-versa.

### 4 Welding procedures for EH47 and crack arrest steels

#### 4.1 General

4.1.1 Test pieces, tests and requirements for approval of the welding procedures are specified in [2.1] to [2.6], unless otherwise specified in this Article.

4.1.2 Where Welding Procedure Specification (WPS) for the non-crack arrest steels has been approved by the Society, the said WPS is applicable to the same welding procedure applied to the same grade with suffix CAS1 or CAS2 specified in Ch 3, Sec 4, Tab 5 except high input processes over 50KJ/cm.

#### 4.2 Parent metal

4.2.1 For EH47, the welding procedure is qualified for the parent metal tested.

#### 4.3 Impact tests

4.3.1 For EH47, the test temperature and absorbed energy for Charpy V-notch impact tests are to be in accordance with Tab 8.

#### 4.4 Hardness tests

4.4.1 An additional row of indentations is to be carried out at mid-thickness.

The results of hardness tests are not to exceed 350HV for EH47 and 380 HV for EH47CAS1 or EH47CAS2.

#### 4.5 Brittle fracture initiation test

4.5.1 Deep notch test or CTOD test may be required for parent metals. Tests are to be in accordance with recognised standards acceptable to the Society.

**Table 8 : Impact test requirements for butt joints (t ≤ 100mm)**

Grade of steel	Testing temperature (°C)	Value of minimum average absorbed energy (J)		
		For manually or semi-automatically welded joints		For automatically welded joints
		Downhand, Horizontal, Overhead	Vertical upward, Vertical downward	
EH47, EH47CAS1, EH47CAS2	- 20	64		



# Section 4 Welding Procedures for other Ship Applications

## 1 General requirements

### 1.1 Approval

1.1.1 Reference is made to general requirements as per Sec 2.

## 2 Welding procedures for cargo tanks and process pressure vessels of liquefied gas carriers

### 2.1 Requirements

2.1.1 Reference is made to the requirements specified in Sec 3, [2.1] to Sec 3, [2.6] as far as applicable taking into account that the requirements of the International Code for the Construction and Equipment of Ships Carrying Liquefied Gases in Bulk (IGC Code) are to be applied.

## 3 Welding procedures for fuel tanks and process pressure vessels of gas fuelled ships

### 3.1 Requirements

3.1.1 Reference is made to the requirements specified in Sec 3, [2.1] to Sec 3, [2.6] as far as applicable taking into account that the requirements of the International Code of Safety for Ships using Gases or other Low-flash point Fuels (IGF Code) are to be applied.

## 4 Welding procedures for Cr-Ni austenitic and austenitic-ferritic stainless steels for application with chemicals

### 4.1 Requirements

4.1.1 Test pieces, tests and requirements for the approval of the welding procedures are agreed on a case-by-case basis and are as far as applicable in accordance with those specified in Sec 3, [2.1] to Sec 3, [2.6].

4.1.2 Checks of the chemical composition of the weld metal may be required and, in the case of austenitic-ferritic steels, the examination of the metallographic structure of the weld for the determination of the average ferrite content is generally to be performed (value required according to ASTM E 562: min. 25% and max. 65%).

Impact tests are not required in the case of austenitic steels and are required in the case of austenitic-ferritic steels and performed at  $-20^{\circ}\text{C}$ ; the average value for the absorbed energy is to be not lower than 27 J.

Conventional corrosion tests according to recognised standards may be required depending on the type of steel.

4.1.3 Typical selection of consumables grades depending on the parent metal to be welded is given in Tab 1.

**Table 1 : Typical selection of consumable grades for welding Cr-Ni austenitic steels**

Consumable grade	Steel grade to be welded
308	304
308L	304 - 304L
316	304 - 316
316L	304 - 304L - 316 - 316L
316LN	304 - 304L - 316 - 316L - 316LN - 316Ti - 316Nb
317	304 - 316 - 317
317L	304 - 304L - 316 - 316L - 317 - 317L
309	309 (1)
309L	309 - 309L (1)
309 Mo	309 - 309Mo - 316 (1)
310	310 (1)
310Mo	310 - 310Mo (1)
347	321 - 347
(1) Also for joints between ferritic and austenitic steels.	

## 5 Approval of welding procedures for copper alloys

### 5.1 Pipes butt weld

#### 5.1.1 Assembly and welding

The applicable requirements of Sec 3, [2.4.1] apply.

The cleaning of the parts to be welded is to be carried out in accordance with the same procedure as used in the construction.

#### 5.1.2 Examinations and tests

Non-destructive examinations and destructive tests required according to Tab 2. The location of the test specimens is to be in accordance with Sec 5, Fig 3.

**Table 2 : Examinations and tests**

Type of examination or test	Extent of examination or test
Visual examination	100%
Radiographic or ultrasonic examination	100%
Dye penetrant test	100%
Transverse tensile tests	2 specimens
Transverse bend tests <b>(1)</b>	2 root and 2 face specimens
Macro examination	1 section
<b>(1)</b> The face and root bends are preferably to be replaced by 4 side bends for $t \geq 12$ mm.	

#### 5.1.3 Non-destructive examinations

Reference is made to Sec 5, [2.1.3].

#### 5.1.4 Transverse tensile tests

Reference is made to Sec 3, [2.1.4].

#### 5.1.5 Bend tests

Reference is made to Sec 5, [2.1.5].

#### 5.1.6 Macro examinations

Reference is made to Sec 5, [2.1.6].

### 5.2 Re-testing

5.2.1 Reference is made to Sec 5, [2.4].

### 5.3 Range of approval

#### 5.3.1 General

Unless otherwise specified in this Article, reference may be made to the applicable requirement in Sec 3, [2.6].

#### 5.3.2 Parent metal

The welding procedure is qualified for the parent metal tested. A change of parent metal may be considered based on the range of approval of a recognized standard acceptable to the Society (e.g. ISO 15614-6).

#### 5.3.3 Thickness

The qualification of a WPS carried out on a test assembly of thickness  $t$  is valid for the thickness range given in the relevant parts of Sec 5, [2.5.3].

#### 5.3.4 Pipe diameter

Reference is made to Sec 3, [2.6.4].

#### 5.3.5 Welding process

For Tungsten Inert Gas arc welding (141) and Plasma Arc Welding (15), the approval obtained is restricted to the type of gas used during the procedure test.

For Oxyacetylene welding (311), the approval obtained with filler metal does not qualify welding without filler metal and vice-versa.

#### 5.3.6 Welding consumables

Welding consumable tested is to be used for the assembly.

5.3.7 Post-weld heat treatment and ageing

The heat treatment used in the qualification is to be maintained during manufacture. Addition or deletion of post-weld heat treatment is not permitted.

5.3.8 Type of joint

Full penetration butt joint in pipes qualifies butt joint in pipes with full or partial penetration.

6 Approval of welding procedure for repair of propeller castings

6.1 Scope

6.1.1 This document gives requirements for qualification tests of welding procedures intended for the repair of cast stainless steel and copper alloy propellers.

6.2 Assembly of test piece

6.2.1 The test assembly, consisting of cast samples, is to be of a size sufficient to ensure a reasonable heat distribution according to Fig 1.

The dimension and shape of the groove shall be representative of the actual repair work.

For cast copper alloy propeller, test sample of minimum thickness 30 mm is to be used.

Preparation and welding of test pieces are to be carried out in accordance with the general condition of repair welding work which it represents.

Figure 1 : Test piece for welding repair procedure

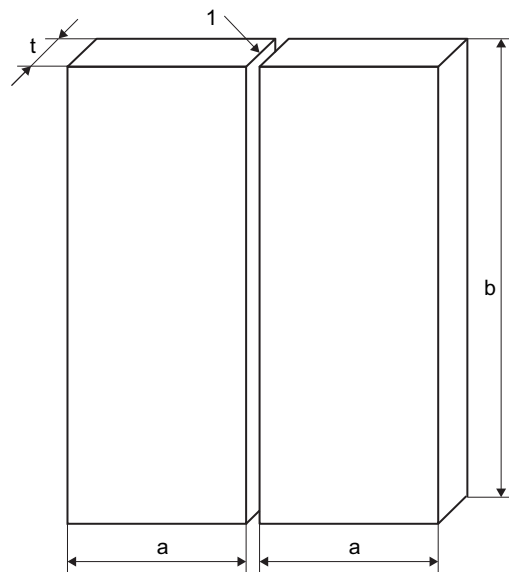

- 1 : Joint preparation and fit-up as detailed in the preliminary Welding Procedure Specification
- a : Minimum value 150 mm
- b : Minimum value 350 mm
- t : Material thickness.

6.3 Examination and tests

6.3.1 Non-destructive examinations and destructive tests required according to Tab 3. The location of the test specimens is to be in accordance with Fig 2 for cast stainless steel propellers and with Fig 3 for cast copper alloy propeller.

6.3.2 Non-destructive testing

Test assembly is to be examined by visual and liquid penetrant testing, or magnetic particle testing if applicable, prior to the cutting of test specimen. In case, that any post-weld heat treatment is required or specified, non-destructive testing is to be performed after heat treatment.

No cracks are permitted. Imperfections detected by liquid penetrant testing are to be assessed in accordance with Ch 6, Sec 8, [1.11] for cast stainless steel propeller and Ch 8, Sec 3, [1.11] for cast copper alloy propeller.

Figure 2 : Weld test assembly

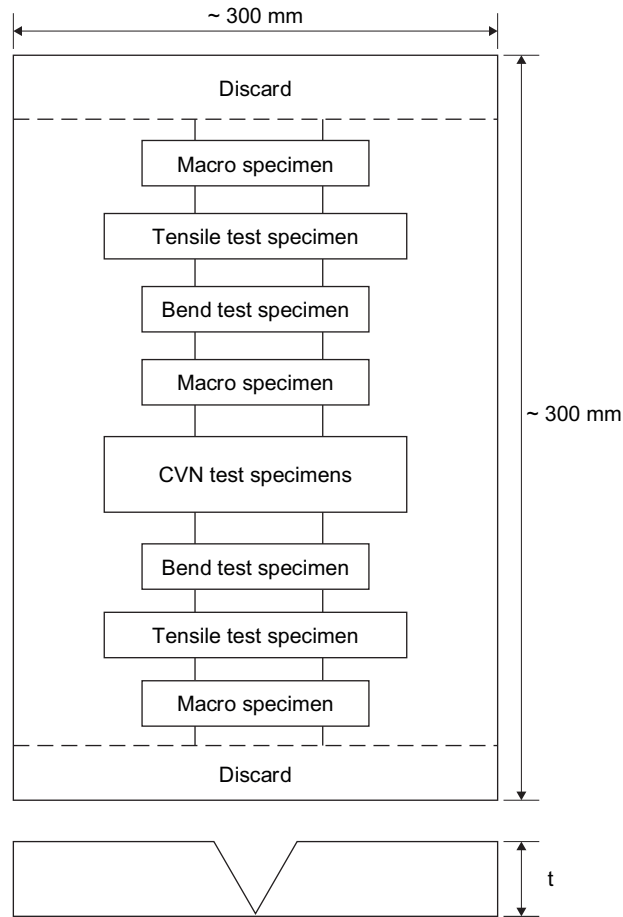
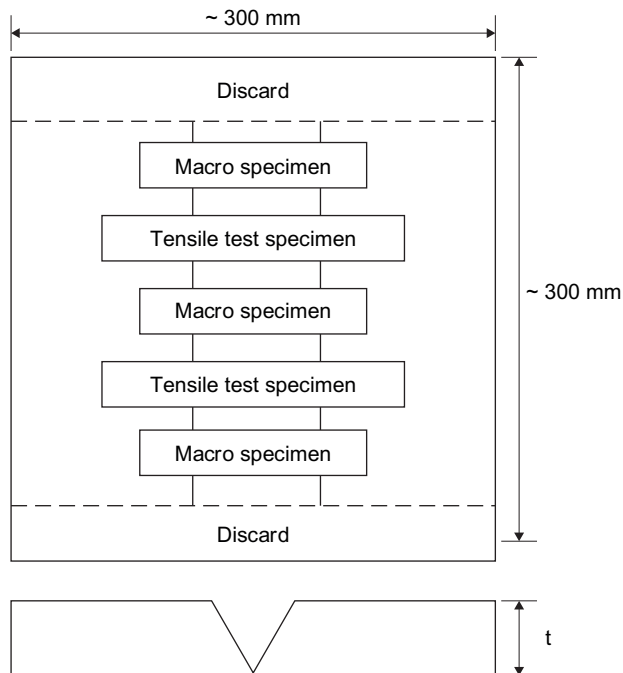

Figure 3 : Test specimen



**Table 3 : Examinations and tests**

Type of examination or test	Extent of examination or test	Remarks
Visual examination	100%	
Liquid penetrant testing (2)	100%	
Transverse tensile tests	2 specimens	
Macro examination	3 specimens	
Bend test (1)	2 root and 2 face specimens	Only for cast stainless steel
Impact test	2 sets of 3 specimens	Only for cast stainless steel
Hardness test	On 1 section	Only for cast stainless steel
(1) The face and root bends may be substituted by 4 side bends for $t \geq 12$ mm.		
(2) Magnetic particle testing may be used in lieu of liquid penetrant testing for martensitic stainless steels.		

**6.3.3 Tensile test**

Two tensile tests are to be prepared as per Ch 2, Sec 2, [1.1.11]. Alternatively tensile test specimens according to recognised standards acceptable to the Society may be used.

For cast stainless steel propeller, the tensile strength shall meet the specified minimum value of the base material. The location of fracture is to be reported (weld metal, HAZ or base material).

For cast copper alloy propeller, the tensile strength shall meet the values given in Tab 4.

**Table 4 : Minimum tensile strength for cast copper alloys**

Grade (Alloy type)	Minimum tensile strength $R_m$ (N/mm <sup>2</sup> )
CU1	370
CU2	410
CU3	500
CU4	550

**6.3.4 Macro examination**

Three test specimens are to be prepared and etched on one side to clearly reveal the weld metal, the fusion line and the heat affected zone.

The test specimens are to be examined for imperfections present in the weld metal and the heat affected zone.

Cracks and lack of fusion are not permitted. Imperfections such as pores, or slag inclusions, greater than 3 mm are not permitted.

**6.3.5 Bend test**

Transverse bend tests for butt joints are to be in accordance with Ch 2, Sec 3 or, according to a recognised standard. The mandrel diameter shall be 4 x thickness except for austenitic stainless steels, in which case the mandrel diameter shall be 3 x thickness.

The bending angle is to be 180°. After testing, the test specimens are not to reveal any open defects in any direction greater than 3 mm. Defects appearing at the corners of a test specimen during testing are to be investigated case by case.

**6.3.6 Impact test**

Impact test is required, where the base material is impact tested. Charpy V-notch test specimens shall be in accordance with Ch 2, Sec 4, [1.2]. Two sets shall be taken, one set with the notch positioned in the center of the weld and one set with the notch positioned in the HAZ (i.e. the mid-point of the notch shall be at 1mm to 2mm from the fusion line), respectively.

The test temperature, and impact energy shall comply with the requirement specified for the base material.

**6.3.7 Hardness test**

The macro-section representing the start of welding shall be used for HV 10 hardness testing. Indentations shall traverse 2mm below the surface. At least three individual indentations are to be made in the weld metal, the HAZ (both sides) and in the base metal (both sides). The values are to be reported for information.

**6.3.8 Re-testing**

If the test fails to comply with any of the requirements of this **Article**, reference is made to re-test procedure given in Sec 3, [2.5].

**6.4 Range of approval**

**6.4.1 General**

Unless otherwise specified in this **Article**, reference may be made to the applicable requirement in Sec 3, [2.6].

**6.4.2 Parent metal**

For cast stainless steel propeller, the welding procedure is qualified for the parent metal tested.  
 For cast copper alloy propeller, the range of qualification is given in Tab 5.

**6.4.3 Thickness**

The qualification of a WPS carried out on a test assembly of thickness t is valid for the thickness range given in Tab 6.

**Table 5 : Range of qualification for parent metal for cast copper alloy propeller**

Copper alloy material grade used for qualification	Range of approval
CU1	CU1
CU2	CU1; CU2
CU3	CU3
CU4	CU4

**Table 6 : Range of qualification for thickness**

Thickness t of test piece, in mm	Range of approval	
	Cast stainless steel propeller	Cast copper alloy propeller
15 < t ≤ 30	3 mm to 2 t	N.A.
t > 30	0,5 t to 2 t (max.200)	N.A.
t ≥ 30	N.A.	≥ 3 mm

**6.4.4 Welding position**

Approval for a test made in any position is restricted to that position.

**6.4.5 Welding process**

The approval is only valid for the welding process used in the welding procedure test. Single run is not qualified by multi-run butt weld test.

**6.4.6 Welding consumable**

The approval is only valid for the welding consumable used in the welding procedure test.

**6.4.7 Heat input**

For cast stainless steel propeller, the upper limit of heat input approved is 15% greater than that used in welding the test piece. The lower limit of heat input approved is 15% lower than that used in welding the test piece.

For cast copper alloy propeller, the upper limit of heat input approved is 25% greater than that used in welding the test piece. The lower limit of heat input approved is 25% lower than that used in welding the test piece.

**6.4.8 Preheating and interpass temperature**

The minimum preheating temperature is not to be less than that used in the qualification test.

The maximum interpass temperature is not to be higher than that used in the qualification test.

**6.4.9 Post-weld heat treatment**

The heat treatment used in the qualification test is to be specified in pWPS. Soaking time may be adjusted as a function of thickness.

**7 Approval of welding procedure for cladding**

**7.1 Requirements**

**7.1.1** Test pieces, tests and requirements for the approval of the welding procedures are to be in accordance with recognised standards such as ISO 15614-7, ASME Section IX.

**7.1.2** When reference is made to a recognised standard, the same standard is to be used for all variables and range of qualifications.

# Section 5 Welding Procedures for Aluminium Alloys

## 1 General requirements

### 1.1 Approval

1.1.1 Reference is made to general requirements as per Sec 2.

## 2 Welding procedures for aluminium alloys

### 2.1 Plates butt weld

#### 2.1.1 Assembly and welding

The applicable requirements of Sec 3, [2.1.1] apply.

The cleaning of the parts to be welded is to be carried out in accordance with the same procedure as used in the construction.

Welding consumables used are to be approved by the Society in accordance with Ch 11, Sec 15.

#### 2.1.2 Examinations and tests

Non-destructive examinations and destructive tests required according to Tab 1. The location of the test specimens is to be in accordance with Fig 1.

**Figure 1 : Location of test specimens for a butt joint in plate**

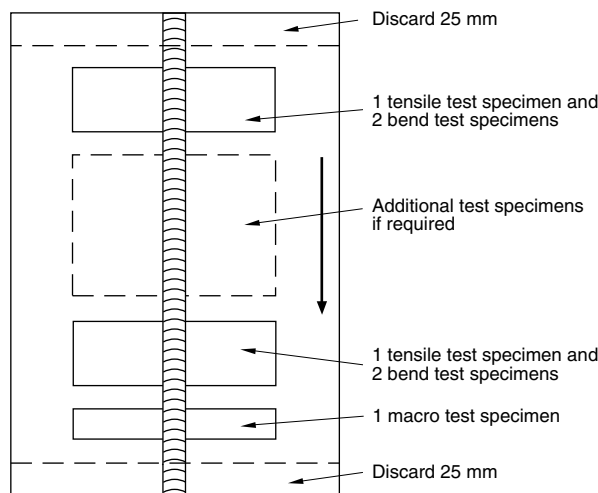

**Table 1 : Examinations and tests**

Type of examination or test	Extent of examination or test
Visual examination	100%
Radiographic or ultrasonic examination	100%
Dye penetrant test	100%
Transverse tensile tests	2 specimens
Transverse bend tests (1)	2 root and 2 face specimens
Macro examination	1 section
Check of Mg content (2)	weld metal

(1) The face and root bends are preferably to be replaced by 4 side bends for  $t \geq 12$  mm.  
 (2) In the case of non-approved filler metal, the check of Mg content and other checks, as appropriate, are generally required.

**2.1.3 Non-destructive examinations**

Non-destructive examinations should be carried out after any required post-weld heat treatment and natural or artificial ageing, and prior to the cutting of test specimens.

Welds should be free from cracks. Imperfections detected by visual or non-destructive testing should be assessed in accordance with ISO 10042:2018, level B, except for excess weld metal or convexity, excess throat thickness and excess of penetration for which the level C applies.

**2.1.4 Transverse tensile tests**

Specimens for transverse tensile tests are to be in accordance with Ch 2, Sec 2, [1.1.11].

The weld is to be made flush maintaining the thickness of the assembly.

The tensile strength results are to meet the requirements stated in Tab 2.

**Table 2 : Minimum tensile strength for series 5000 and 6000 alloys**

Grade (Alloy designation)	Minimum tensile strength R <sub>m</sub> (N/mm <sup>2</sup> )
5754	190
5086	240
5083	275
5383	290
5059	330
5456	290
6005 A	170
6061	170
6082	170

**2.1.5 Bend tests**

Transverse root bend, face bend and side bend specimens are to be machined to the dimensions given in Ch 2, Sec 3, [1.1].

For dissimilar or heterogeneous butt joints, longitudinal bend test may be used instead of transverse bend tests.

The bend test specimens should be bent on a mandrel with maximum diameter as given in the formula below. The bending angle shall be 180°.

$$d = \frac{(100 \times t_s)}{A} - t_s$$

where:

d : Maximum former diameter

t<sub>s</sub> : Thickness of the bend test specimen (this includes side bends)

A : Minimum tensile elongation required by the alloy grade, temper condition and thickness (for combination between different alloys, the lowest individual value should be used).

The “wrap around bending method” is the recommended bending procedure in lieu of the usual “free” bend test (see Fig 2).

After testing, the test specimens are not to reveal any open defect in any direction greater than 3 mm. Defects appearing at the corner of the test specimen may be disregarded unless there is evidence that they result from lack of fusion.

**2.1.6 Macro examination**

The test specimens are to be prepared and etched on one side to clearly reveal the fusion line, the HAZ, the build up of the runs and the unaffected parent metal. The examination is to reveal a regular weld profile, through fusion between adjacent layers of weld and base metal, and the absence of defects such as cracks and lack of fusion.

The acceptance levels are given in [2.1.3].

**2.2 Plates fillet weld**

**2.2.1 Assembly and welding**

The requirements of Sec 3, [2.3.1] apply except otherwise specified in the following.

The cleaning of the parts to be welded is to be carried out in accordance with the same procedure as used in the construction.

The two plates are to be positioned and tack welded edgewise so as to constitute a T assembly without clearance.

Welding on one or both sides and fit up are to be as detailed in the pWPS.

In general for semi-automatic welding a stop/restart position is to be included in the test length and is to be clearly marked for subsequent examination.

**2.2.2 Examinations and tests**

Non-destructive examinations and destructive tests are to be carried out in accordance with the requirements of Tab 3.



Figure 2 : Wrap around bend test

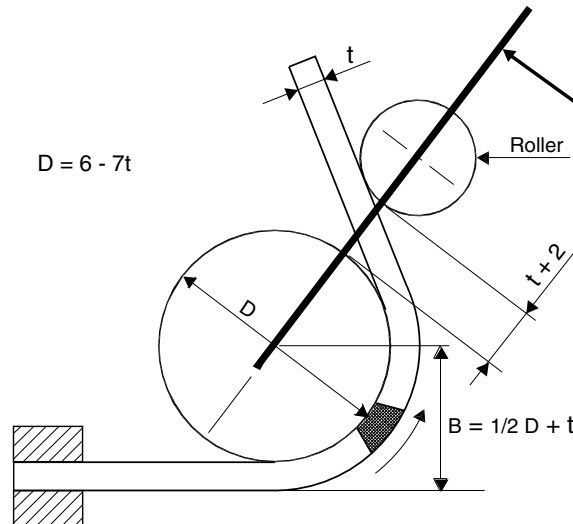

The fixed edge of the test specimen is to be clamped to avoid sliding. The whole welded zone (weld and heat affected zone), in the case of transverse bending, is to be entirely positioned in the bent zone.

Table 3 : Examinations and tests

Type of examination or test	Extent of examination or test
Visual examination	100%
Dye penetrant test	100%
Macro examination (1)	2 specimens
Fracture test	1 specimen
(1) One of the macro sections is to be taken at the position of the stop/restart (see [2.2.1]).	

**2.2.3 Visual examination and surface crack detection**

The requirements specified in [2.1.3] are to be complied with.

**2.2.4 Macro examination and fracture test**

The fracture test as well as the macro examination are to show, in general, the absence of defects, in particular lack of root penetration.

However in the macro examination, small soundness defects of the weld metal such as blowholes or inclusions may be accepted provided that their total area does not exceed 6% of the weld metal section examined.

The dimensions of leg size, throat and penetration are generally to be reported.

**2.3 Pipes butt weld with full penetration**

**2.3.1 Assembly and welding**

The applicable requirements of Sec 3, [2.4.1] apply.

The cleaning of the parts to be welded is to be carried out in accordance with the same procedure as used in the construction. If the tack welds are a condition of the weld process they are to be fused into the joint and are to be included in the test pieces.

**2.3.2 Examinations and tests**

Non-destructive examinations and destructive tests required according to Tab 1. The location of the test specimens is to be in accordance with Fig 3.

**2.3.3 Results**

The results are to comply with the requirements for plates butt weld in [2.1].

**2.4 Re-testing**

**2.4.1** If the test piece fails to comply with any of the requirements for visual or non-destructive testing, one further test piece is to be welded and subjected to the same examination.

If this additional test piece does not comply with the relevant requirements, the pWPS is to be regarded as not capable of complying with the requirements without modification.

Figure 3 : Location of test specimens

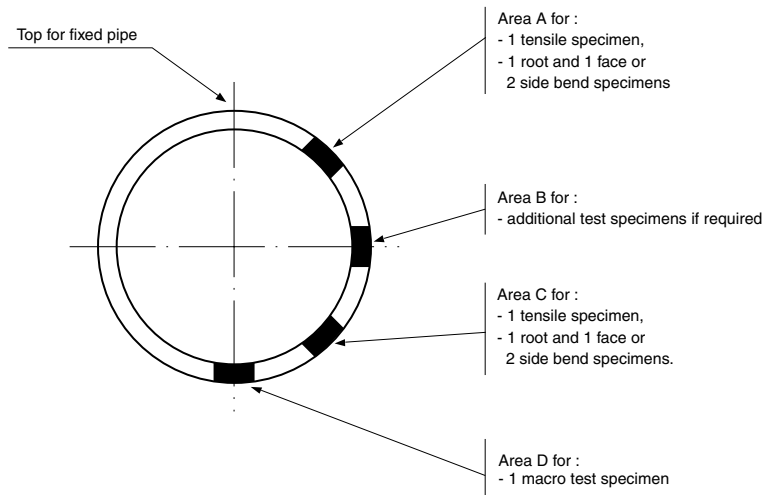

**2.4.2** If any test specimens fails to comply with the relevant requirements for destructive testing due to weld imperfection only, two further test specimens shall be obtained for each one that failed. These specimens can be taken from the same test piece if there is sufficient material available or from a new test piece, and is to be subjected to the same test. If either of these additional test specimens does not comply with the relevant requirements, the pWPS is to be regarded as not capable of complying with the requirements without modification.

**2.4.3** If a tensile test specimen fails to meet the requirements, the re-testing is to be in accordance with Ch 2, Sec 2, [1.3].

## 2.5 Range of approval

### 2.5.1 General

Unless otherwise specified in this **Article**, reference may be made to the requirements in Sec 3, [2.6].

### 2.5.2 Parent metal

The alloys are grouped into three groups:

- Group A: Aluminium-magnesium alloys with Mg content  $\leq 3,5\%$  (alloy 5754)
- Group B: Aluminium-magnesium alloys with  $4\% \leq \text{Mg} \leq 5,6\%$  (alloys 5059, 5083, 5086, 5383 and 5456)
- Group C: Aluminium-magnesium-silicon alloys (alloys 6005A, 6061 and 6082).

For each group, qualification tests made on one alloy qualify the procedure for the other alloys of the same group with equal or lower minimum specified tensile strength after welding.

Qualification on Group B alloys qualify the procedure for Group A alloys.

### 2.5.3 Thickness

The qualification of a WPS carried out on a test assembly of thickness  $t$  is valid for the thickness range given in Tab 4.

In case of butt-joints between dissimilar thickness,  $t$  is the thickness of the thinner metal

In case of fillet joints between dissimilar thickness,  $t$  is the thickness of the thicker metal.

In addition to the requirements of Tab 4 the range of qualification of the fillet welds throat thickness  $a$  is given in Tab 5.

Where a fillet weld is qualified by means of a butt weld test, the throat thickness range qualified should be based on the thickness of the deposited weld metal.

Where the majority of production work is fillet welding, an additional fillet weld test may be required.

### 2.5.4 Pipe diameter

Qualification tests on an assembly of pipes of diameter  $D$  is valid for diameters in the range given in Sec 3, Tab 6.

### 2.5.5 Welding positions

The test pieces are to be welded in the position(s) used in the construction taking into account that:

- Horizontal-vertical position qualifies also for flat and vertical upwards positions
- Vertical upwards position qualifies also for flat and horizontal-vertical positions
- Overhead position qualifies also for flat, vertical upwards and horizontal-vertical positions.

**Table 4 : Range of qualification for parent material thickness**

Thickness t of the test piece (mm)	Range of qualifications
$t \leq 3$	0,5 to 2 t
$3 < t \leq 20$	3 to 2 t
$t > 20$	$\geq 0,8 t$

**Table 5 : Range of qualification for the throat thickness of fillet welds**

Throat thickness a of the test piece (mm)	Range of qualifications
$a < 10$	0,75 a to 1,5 a
$a \geq 10$	$\geq 7,5$

**2.5.6 Welding process**

The approval is valid only for the welding process used in the welding procedure test. It is not permitted to change a multi-run deposit into a single run (or run on each side) or vice versa for a given process. In the case of a multi-process procedure, the approval is only valid for applying the processes in the order used during the procedure qualification tests.

Note 1: For multi-process procedures each welding process may be approved separately or in combination with other processes. Similarly one or more processes may be deleted from an approved WPS provided the joint thickness is within the approved thickness range of the relevant welding process to be applied.

**2.5.7 Welding consumables**

The welding consumable used in the qualification tests qualifies:

- a) Approved welding consumables of the same strength as the consumable used in the procedure qualification tests.
- b) Approved welding consumables of higher strength than the consumable used in the procedure qualification tests.

The qualification given to shielding gas and backing gas is restricted to the gas/gas mixture used in the welding procedure test, see ISO 14175:2008 or other recognised standards for gas designations.

**2.5.8 Type of current**

Changes in the type of current (AC, DC, pulsed) and polarity require a new welding procedure qualification.

**2.5.9 Post-weld heat treatment or ageing**

Addition or deletion of post-weld heat treatment or ageing is not permitted. Artificial ageing for 6000 series alloys gives approval for prolonged natural ageing.

**2.5.10 Type of joint**

The range of approval for the types of joint in relation to the type of joint used in the procedure qualification test is given in Tab 6.

**Table 6 : Range of approval for type of joint**

Type of welded joint for test assembly			Range of approval				Fillet welds on plate and pipe
			Butt welds for plates with full or partial penetration				
			Welded from one side		Welded from both sides		
			with backing	no backing	with gouging	no gouging	
Butt joint welded	One side (1)	with backing	◊	–	x	–	x
		no backing	x	◊	x	x	x
	Both sides	with gouging	–	–	◊	–	x
		no gouging	x	–	x	◊	x
Fillet weld for plates	–	–	–	–	–	–	◊

**Note 1:**

◊ indicates the type of assembly of qualification test.

x indicates on the same line as the symbol ◊ those welds for which the WPS is also approved.

– indicates on the same line as the symbol ◊ those welds for which the WPS is not approved.

(1) Butt welds on a plate welded from one side approve butt welds on pipes having diameter > 500 mm within the limitations of the Table.

## Section 6

# Welding Procedures for Offshore Structures and Equipment

### 1 General requirements

#### 1.1 Approval

**1.1.1** The applicable requirements are given in Rule Note NR426 “Construction Survey of Steel Structures of Offshore Units and Installations”, as amended.

# Section 7 Welding Procedures for CO<sub>2</sub> Laser

## 1 General requirements

### 1.1 Approval

1.1.1 Reference is made to general requirements as per Sec 2.

## 2 Welding procedures for CO<sub>2</sub> laser

### 2.1 Scope

2.1.1 The requirements of this Section apply to the approval of CO<sub>2</sub> laser welding procedures for butt- and T- joints in hull construction. Stake welding is not covered by these requirements.

### 2.2 General requirements

2.2.1 The user’s workshop is to demonstrate by means of a weld procedure approval test and examination of the first production welds, that the welds produced under the normal conditions are sound and have the required mechanical properties.

2.2.2 The approval is granted for a defined range of applications (materials, plate thicknesses, seam preparation, tolerances, etc.) and for specific characteristic welding parameters (laser power, welding speed, welding consumables, etc.), in accordance with the samples welded during the procedure qualification tests.

Normally, changes in essential variables outside the approved range (see Article [8]) require supplementary tests or new qualification.

### 2.3 Welding procedure specification

2.3.1 A welding procedure specification is to be prepared by the Manufacturer and proposed for approval; this document is also referred to as preliminary welding procedure specification (pWPS) and is to be modified and amended during the procedure tests as deemed necessary.

In its final version, the welding procedure specification (WPS) is to include all the welding parameters and main data affecting the quality of welded joints and is to be used as a basis for the laser production welds.

### 2.4 Parent metal

2.4.1 In addition to the structural steels defined in Ch 3, Sec 2, two new grades of steel have been defined with a narrower range of chemical composition.

These grades, designated L24 (normal steel) and L36 (higher strength steel), have the chemical composition indicated in Tab 1; for elements not indicated in this Table, the limits are those of the standard steels defined in Ch 3, Sec 2, Tab 2. The steels are to comply with the requirements in Ch 3, Sec 2.

**Table 1 : L24 and L36 steel chemical composition**

Elements	Ladle analysis (%)
C	≤ 0,12
Mn	0,90 - 1,60 <b>(1)</b>
Si	0,10 - 0,50
S	≤ 0,005
P	≤ 0,010
C <sub>EQ</sub> <b>(2)</b>	≤ 0,38
P <sub>cm</sub> <b>(3)</b>	≤ 0,22

**(1)** Manganese may be reduced to 0,70% for L24 grade consistent with the lowest values used in the weld procedure test.

**(2)** 
$$C_{EQ} = C + \frac{Mn}{6} + \frac{Cr + Mo + V}{5} + \frac{Ni + Cu}{15} \quad \%$$

**(3)** 
$$P_{cm} = C + \frac{Si}{30} + \frac{Mn}{20} + \frac{Cu}{20} + \frac{Ni}{60} + \frac{Cr}{20} + \frac{Mo}{15} + \frac{V}{10} + 5B \quad \%$$

**2.4.2** Steels having chemical composition different from that indicated in Tab 1 may be used provided that satisfactory results are obtained in the approval tests and production welds.

In particular, the following deviation from the standard composition given in Tab 1 may be specially considered subject to an adequate limitation of the welding speed, e.g. 0,6 m / 1' for a thickness of 12 mm or 2 m / 1' for a thickness less than or equal to 6 mm:

- $C \leq 0,15\%$  subject to a reduction in welding speed and/or increase in applied energy in respect of the values found adequate for the maximum level of C 0,12%,
- $S \leq 0,010\%$  and  $P \leq 0,015\%$  for a material thickness less than or equal to 12 mm, or
- $S \leq 0,017\%$  and  $P \leq 0,018\%$  for a material thickness less than or equal to 6 mm.

## **2.5 Welding consumables**

**2.5.1** Welding consumables and auxiliary materials are to be approved by the Society and are to be clearly defined in the WPS.

## **3 Approval of welding procedure**

### **3.1 General**

**3.1.1** Qualification tests are to be carried out in the presence of the Surveyor at the user's workshop under fabrication conditions.

**3.1.2** Approval of the welding procedure is subject to the acceptance of the first production welds.

### **3.2 Assembly and welding**

**3.2.1** Butt-joint test assemblies and/or T-joint test assemblies are to be selected in accordance with the range of application applied for approval.

**3.2.2** Test assemblies are to be of a sufficient size to ensure reasonable heat distribution during welding and to provide for the required test specimens, after sufficient discard at the ends.

Unless otherwise agreed, the dimensions are to be in accordance with [5.1.2] and [6.1.1].

**3.2.3** Welding is to be carried out in accordance with the pWPS and under the general conditions of production welding which they represent.

**3.2.4** The type of joint preparation including tolerances is to be representative of the fabrication welds. Maximum and minimum values of tolerances are to be incorporated in the weld procedure test.

Where gaps are required, the minimum and the maximum values are to be verified on two procedure tests.

**3.2.5** The plates are to be held in place by clamps, or other suitable holding devices, or by tack welds as provided for fabrication welding. If tack welds are to be used in the fabrication, they are to be included in the test pieces.

**3.2.6** The welding parameters are to be recorded and are to be in accordance with the pWPS. Each test piece is to contain at least one stop/restart of the welding process.

## **4 Non-destructive examinations**

### **4.1 General**

**4.1.1** Prior to the cutting of the test specimens, non-destructive examinations are to be carried out over the entire length of the weld.

**4.1.2** Where automatic non-destructive examinations are used in fabrication (e.g. ultrasonic), the test piece is to be subjected to such examinations.

**4.1.3** Imperfections detected by visual or other non-destructive examination are to be assessed in accordance with EN ISO13919-1 level C.

## **5 Plates butt welds**

### **5.1 Assembly**

**5.1.1** The weld direction is to be perpendicular to the rolling direction of the plate and is to be marked on the test piece.

Where impact tests are prescribed for the base metal in the transverse direction, the weld direction is to be parallel to the rolling direction of the plate (see Fig 1).

Figure 1 : Butt weld test assembly with Charpy impact test

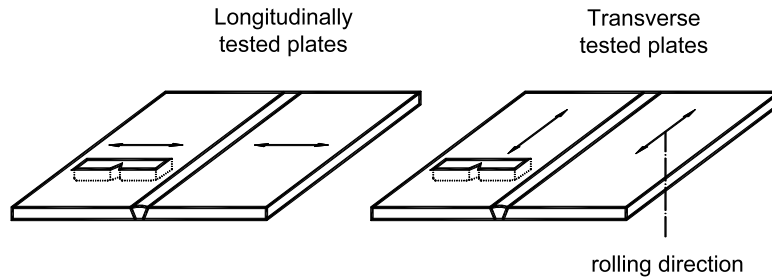

5.1.2 The dimension of the butt weld test assembly is to be in accordance with Fig 2.

The dimensions in Fig 2 are as follows:

- W = 300 mm min.
- L = 300 mm min.
- D = 25 mm max. for thickness ≤ 25mm
- D = 50 mm max. for thickness > 25mm.

Figure 2 : Butt weld test assembly

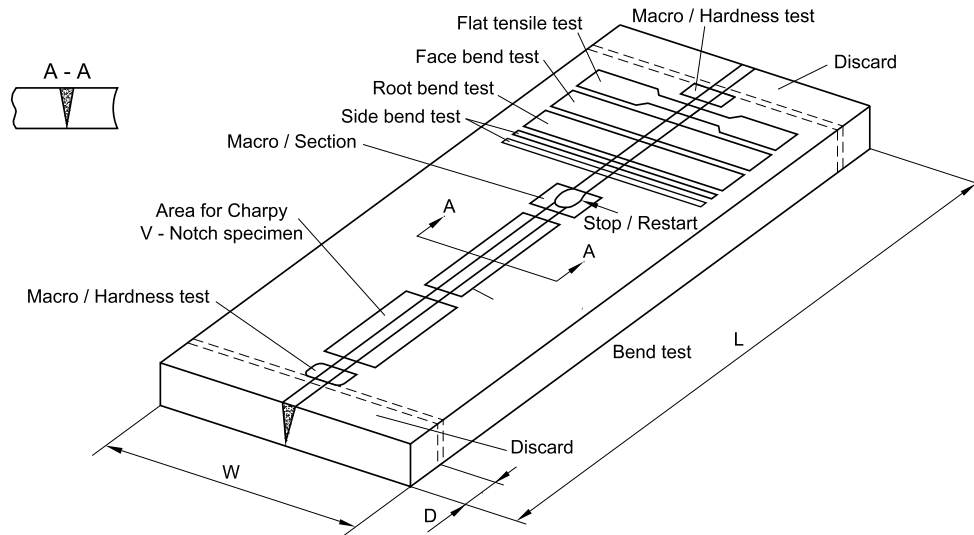

## 5.2 Examinations and tests

### 5.2.1 General

Non-destructive examinations and destructive tests are to be in accordance with the requirements of Tab 2, while the location of the test specimens is to be in accordance with Fig 2.

Table 2 : Examinations and tests

Type	Extent
Visual examination	100%
Radiographic examination	100%
Magnetic particle examination	100%
Transverse tensile test	2 specimens
Transverse bend tests (1)	2 root and 2 face specimens
Longitudinal bend test	1 face specimen
Impact tests (2)	3 sets
Macro examination	3 sections
Hardness test	2 sections
(1) The face and root bends are preferably to be replaced by 4 side bends for $t \geq 12$ mm.	
(2) 3 sets of 3 specimens as per [5.5.1].	

### 5.2.2 Non-destructive examinations

The requirements in Article [4] are to be complied with. Special attention is to be paid to the stop/restart positions with respect to profile, proper fusion and absence of cracks and porosity.

### 5.3 Tensile tests

**5.3.1** Transverse tensile test specimen and procedure is to be in accordance with Chapter 2.

**5.3.2** The tensile strength is to be not lower than the specified minimum tensile strength of the parent material. The location of the fracture is to be reported, i.e. weld metal, HAZ, parent metal.

### 5.4 Bend tests

#### 5.4.1 Bend test

Transverse, side and longitudinal bend specimens are to be in accordance with Ch 1, Sec 2.

The test specimens are to be bent on a mandrel having a diameter 3,5 times the thickness of the specimen; the bending angle is to be 180°.

**5.4.2** During the test, the specimens are not to reveal any open imperfection, in any direction, greater than 3 mm. Defects not initiated by a weld defect appearing at the corner of the test specimen are disregarded.

### 5.5 Impact tests

**5.5.1** Charpy V-notch impact tests are to be taken 1 mm below the surface of the sample transverse to the weld and with the notch perpendicular to the material surface; they are to be machined to the dimensions indicated in Ch 2, Sec 4, [1.2.1].

Three sets of Charpy V-notch specimens, each set including 3 specimens, are to be taken as follows:

- one set with the notch along the weld metal centre line with tolerance  $\pm 0,1$  mm
- one set with the notch in the heat affected zone (HAZ)
- one set with the notch in the parent metal.

The direction of fracture is to coincide with the weld direction (see Fig 3). The parent material specimens are to have the same orientation as the specimens from the weld joint.

**Figure 3 : Fracture direction of Charpy impact tests**

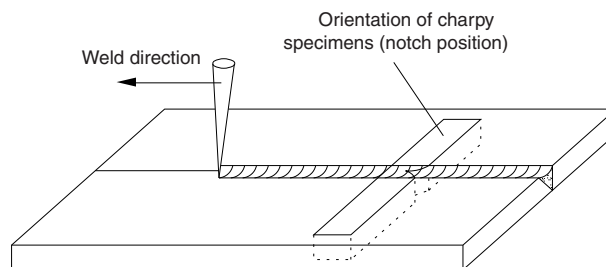

**5.5.2** The test temperature and the results are to comply with the requirements specified for the parent metal.

**5.5.3** Requirements for reduced Charpy V specimens are given in Ch 2, Sec 4, [1.2.2].

**5.5.4** The Society may require additional tests, e.g. Charpy tests with other notch locations, and other or additional temperatures or CTOD tests.

### 5.6 Hardness measurements

#### 5.6.1 Hardness test

The Vickers method HV10 is generally to be used.

The indentations are to be made in the weld, heat affected zones (HAZ) and the parent metal, with the object of measuring and recording the range of values in the weld joint (see Fig 4). For butt welds, the upper and lower rows are to transverse 2 mm maximum below the surface, depending on the plate thickness.

For each row of indentations, a minimum of 3 individual indentations is required in the weld, both sides of the HAZ and the parent metal.

For the HAZ, the indentations are to be placed as close as possible to the fusion line.

**5.6.2** Where no filler metal or low hydrogen welding consumables (H5) are used in the procedure, values not higher than 380HV are considered acceptable; one individual value not higher than 400HV is accepted for each section.

Values not higher than 350HV are required in all other cases.



Figure 4 : Butt weld hardness indentations

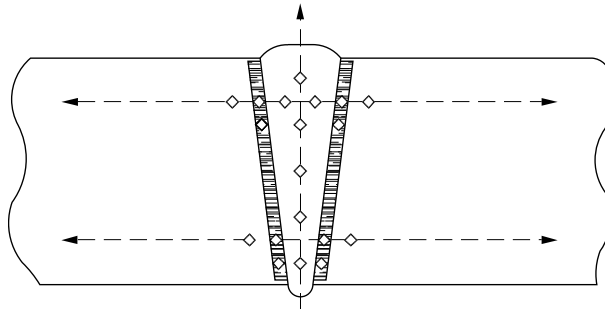

5.7 Metallographic examination

5.7.1 The three macro sections are to be taken as shown in Fig 2.

One section is to be a length of weld including a stop/restart position. This longitudinal section is to be cut as shown in Fig 5 and examined at the mid-thickness of the plate.

5.7.2 The test specimens are to be prepared and etched on one side only to clearly reveal the fusion line, the HAZ, the solidification structure of the weld metal and the unaffected parent metal.

5.7.3 The sections are to be examined by the naked eye (or by low power hand lens if deemed necessary) for any imperfection present in the weld metal and HAZ and for unsatisfactory profile features. Any imperfections are to be assessed in accordance with Article [4].

5.7.4 The weld shape is to be within the limits specified in Fig 6. For thicknesses up to 8 mm, lower values for “d” and “d<sub>1</sub>” may be accepted at the discretion of the Society.

Figure 5 : Longitudinal mid-thickness macro section

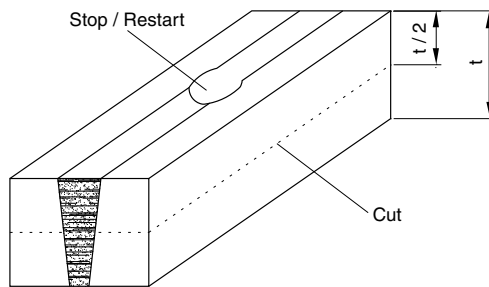
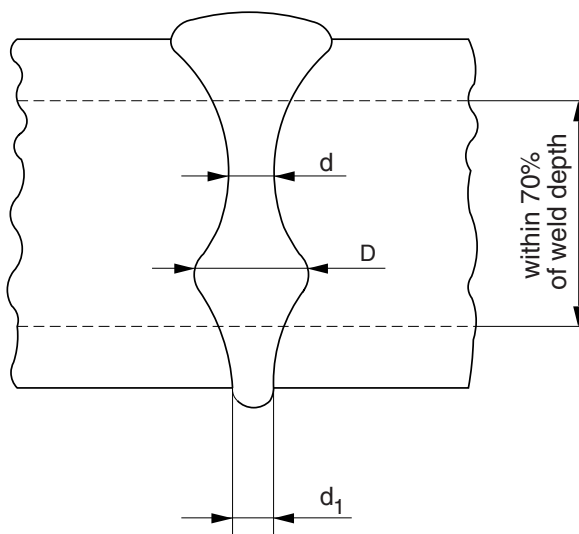

Figure 6 : Weld shape limitations



- d : Minimum weld width, with  $d \geq 1,5$  mm
- d<sub>1</sub> : Weld root width, with  $d_1 \geq 1,0$  mm
- D/d : Secondary wide zone “bulge”, if bulging occurs  $D/d \leq 1,2$

## 6 T joint weld procedure test

### 6.1 Assembly

6.1.1 The dimensions of the T-joint weld test assembly are to be in accordance with Fig 7.

The dimensions in Fig 7 are as follows:

- W = 300 mm min.
- L = 1000 mm min.
- D = 50 mm max.

### 6.2 Examinations and tests

#### 6.2.1 General

Non-destructive examinations and destructive tests are to be in accordance with the requirements of Tab 3, while the location of the test specimens is to be in accordance with Fig 7.

#### 6.2.2 Non-destructive examination

The requirements in Article [4] are to be complied with. Special attention is to be paid to the stop/restart positions with respect to profile, proper fusion and absence of crater defects.

#### 6.2.3 Macro examination

The three macro sections are to be taken as shown in Fig 7.

Two sections are to be taken from the ends adjacent to the discards, the third from the middle of the length.

#### 6.2.4 Hardness test

Hardness indentations are to be made as shown in Fig 8 in accordance with [5.6.1], as appropriate. All hardness values are to be recorded. The values are to comply with the requirements in [5.6.2].

Figure 7 : T-joint test assembly

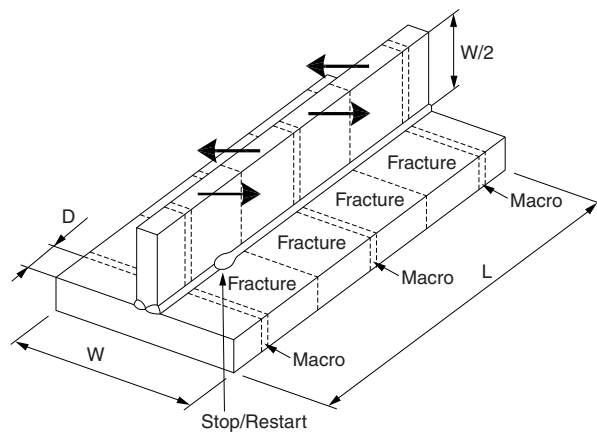

Figure 8 : T joint weld hardness indentations

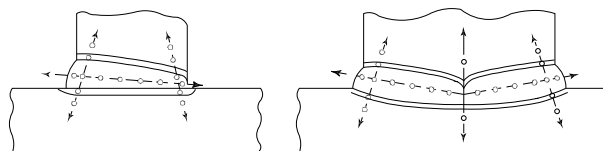

Table 3 : Examinations and tests

Type	Extent
Visual examination	100%
Magnetic particle examination	100%
Ultrasonic examination	100%
Macro examination	3 sections
Hardness test	3 sections
Break test	4 specimens <b>(1)</b>
<b>(1)</b> One specimen is to be taken from the stop/restart position.	

**6.2.5 Break test**

Break test specimens are to be taken from the length of the welded assembly remaining after removal of the macro sections. Four test specimens (not less than 100 mm each in length) are to be taken and fractured by folding the upright plate in alternate directions onto the through plate (see Fig 7).

A saw cut may be made to facilitate breaking in accordance with Fig 9.

The fracture surfaces are to be examined for possible defects which are to be assessed in accordance with Article [4].

Note 1: If a break in the weld cannot be obtained, an alternative is to machine the base plate flush to the web and to X-ray the weld in the direction of weld centre line.

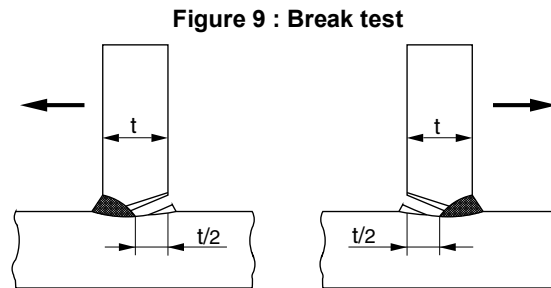

**7 Re-testing**

**7.1 Non-destructive and destructive tests**

**7.1.1** If the test piece fails to comply with any of the requirements for visual or non-destructive testing, one further test piece is to be welded and subjected to the same examination.

If this additional test piece does not comply with the relevant requirements, the pWPS is to be regarded as not capable of complying with the requirements without modification.

**7.1.2** If any test specimens fails to comply with the relevant requirements for destructive testing due to weld imperfection only, two further test specimens shall be obtained for each one that failed. These specimens can be taken from the same test piece if there is sufficient material available or from a new test piece, and is to be subjected to the same test. If either of these additional test specimens does not comply with the relevant requirements, the pWPS is to be regarded as not capable of complying with the requirements without modification.

**7.1.3** If a tensile test specimen fails to meet the requirements, the re-testing is to be in accordance with Ch 2, Sec 2, [1.3].

**7.1.4** The re-testing of Charpy V-notch impact test specimens are to be carried out in accordance with Ch 2, Sec 4, [1.4].

**8 Range of approval**

**8.1 Parent metal**

**8.1.1** Approval is given to that grade tested.

**8.2 Thickness**

**8.2.1** The approval of a procedure carried out on a welded assembly of thickness  $t$  is valid for the range  $0,80t$  to  $1,2t$ . Speed and power may be changed within the limitations in [8.6.2].

**8.3 Edge preparation and surface condition**

**8.3.1 Cutting process**

The cutting processes are as follows:

- thermal cut
- thermal cut and sand blasted
- thermal cut and ground
- milled.

Other cutting methods, such as mechanical cutting (shearing), may be considered analogously depending on their edge geometry and surface condition. A change in the cutting process requires new qualification.

**8.3.2 Surface condition**

Any major change in surface condition, such as a change from uncoated to shop primer coated surfaces, requires new qualification. In this context, special attention is to be paid to T-joint configurations.

## **8.4 Joint type, bevel**

**8.4.1** Butt-joints cannot cover T-joints and vice versa.

**8.4.2** Any change in joint geometry with respect to that specified in the welding procedure qualification report (WPQR) requires new qualification.

## **8.5 Welding machine**

### **8.5.1 Laser machine**

A procedure approved for use on one laser machine is valid for that machine and beam shape only. The approval is valid for the focusing system used at the approval tests.

### **8.5.2 Modification of laser machine**

Modifications carried out on an approved laser machine or the use of other laser machines having the same technical specification (from the laser beam technology point of view) only required a reduced re-approval test, if the beam parameters are within the approved range.

## **8.6 Welding parameters**

### **8.6.1 General**

Variations within the limits described below in the welding speed, laser power, focusing parameters and wire feed rate are allowed to accommodate changes in material thickness or fit-up, without need for re-approval. Monitoring of welding parameters within a given procedure setting is to be applied.

### **8.6.2 Laser power and welding speed**

The parameter (laser power / thickness x speed) is to be within the range 90-120% of that originally approved (while also maintaining the welding speed above 0,6 m/1').

For each resetting of parameters, one test sample is to be taken and verified for weld profile shape and freedom from defects by non-destructive examination.

### **8.6.3 Wire feed speed**

The wire feed speed is to be maintained within the limits established by the procedure tests.

### **8.6.4 Focusing optic and focus position**

The focusing parameters are to be kept within the limits specified in accordance with recognised standards.

### **8.6.5 Number of runs**

A change in the number of passes requires a new approval.

### **8.6.6 Process and shielding gas**

Any change in shielding gas or plasma control gas composition requires a new approval.

A change in the flow rate up to 10% is admitted.

### **8.6.7 Welding position**

A change of the welding position requires a new approval.

### **8.6.8 Welding consumables**

Any change of welding consumables requires a new approval.

### **8.6.9 Other variables**

The range of approval related to other variables may be taken according to established practice as represented in recognised standards.

# Section 8 Welding Procedures for Friction Stir Welding

## 1 Requirements

### 1.1 Scope

1.1.1 The requirements of this Section apply to the approval of friction stir welding procedures for butt joints in aluminium hull construction procedure.

### 1.2 Welding procedure

#### 1.2.1 Preliminary welding procedure specification

A preliminary welding procedure specification (pWPS) is to be prepared by the Manufacturer or Shipyard which intends to perform the qualification tests.

This pWPS may be modified and amended during the procedure tests as deemed necessary however it shall define all relevant variables as mentioned in the welding procedure specification, see .

In case that test pieces welded according to the pWPS show unacceptable results the pWPS shall be adjusted by the Manufacturer or Shipyard. The new pWPS shall be prepared and the test pieces welded in accordance with the new pWPS.

In general, the qualification tests shall reflect fabrication conditions in respect to welding equipment, weld preparation, preheating and any post-weld heat treatment. It shall be the manufacturer's responsibility to establish and document whether a procedure is suitable for the particular application.

The test pieces are to be chosen so as to cover all the production welds in accordance with the approval range of parameters given in [1.4].

#### 1.2.2 Approval of welding procedure specification

The qualification tests are to comply with the requirements of ISO 25239-4, welding of test pieces according to the proposed pWPS and testing of test specimens, are to be witnessed by the Surveyor.

Upon satisfactory completion of the tests, the Society may approve the pWPS as a welding procedure specification. The technical content of the pWPS is to comply with the requirements of ISO 25239-4.

In its final version, the welding procedure specification (WPS) is to include all the parameters characterising the welding process.

The actual parameters used for welding the approval test pieces and the results of the inspections and tests carried out are to be recorded in the welding procedure qualification record (WPQR) also referred to as welding procedure approval record (WPAR).

The WPQR is generally prepared by the shipyard or welding shops and endorsed by the attending Surveyor.

#### 1.2.3 Inspections

Inspections and control tests may be periodically and randomly required as deemed necessary by the Society and are to yield satisfactory results in order to maintain the validity of the approval.

The results of any suitable control performed during production may be accepted, to the Surveyor's satisfaction.

#### 1.2.4 Responsibilities of the users

The qualification tests are intended to verify that a manufacturer is adequately qualified to perform welding operations using a particular procedure.

Irrespective of the inspections carried out by the Surveyor, the user is responsible for the use of the approved procedures, within the limits of the range qualified and the conditions stated at the time of the approval.

Compliance with the above is essential for the validity of the approval.

### 1.3 Range of approval

#### 1.3.1 General

The approval of a WPS obtained by a yard or Manufacturer is valid for welding in workshops under the same technical and quality management, to the Society's satisfaction.

The welding procedure is to be used within the range of the parameters indicated below; changes outside the range specified of one or more of these parameters require a new qualification test.

#### 1.3.2 Parent metal

The welding procedure is qualified for the parent metal tested.

#### 1.3.3 Thickness

The welding procedure is qualified for the thickness of the test piece in the qualification test.

### 1.3.4 Pipe diameter

The welding procedure is qualified for the diameter of the test piece in the qualification test.

### 1.3.5 Welding positions

Approval for a test made in any position is restricted to that position.

### 1.3.6 Welding tool

The welding procedure is qualified for the welding tool type used in the qualification test.

### 1.3.7 Type of joint

The welding procedure is qualified for the joint type used in the qualification test.

### 1.3.8 Others

A range of approval for any other variables will be subject to special consideration.

# NR216

## Rules on Materials and Welding

---

### CHAPTER 13

## OTHER PRODUCTS

---

- Section 1      Approval of Over Weldable Shop Primers
- Section 2      Side Scuttles, Windows and their Glass Panes
- Section 3      Pressure Bottles

# Section 1 Approval of Over Weldable Shop Primers

## 1 Scope

### 1.1 General

1.1.1 Shop primers applied on plates and sections to be welded without being removed are to be approved by the Society in accordance with the procedure detailed in this Section.

1.1.2 The approval is limited to the following welding processes:

- manual metal arc welding with covered electrode
- flux-cored wire metal arc welding
- solid wire metal arc welding.

The acceptance of shop primers for use with welding processes other than those above will be specially considered in connection with the approval of the welding procedure at the user's works.

## 2 Information and documentation to be submitted

### 2.1 General

2.1.1 The application for approval is to be submitted to the Society by the shop primer Manufacturer or authorised supplier.

2.1.2 The following information and supporting documentation, as applicable, are to be submitted:

- type designation, product name
- product description including components of the primer, type of diluent and mixture ratio
- product specification, data sheet giving characteristics of the shop primer and application instruction (surface preparation, method of application, drying time, recommended dry coat thicknesses, etc.)
- documentation relevant to previous tests and approvals.
- welding procedure specifications used
- approval test results (see [3]).

## 3 Approval tests

### 3.1 Base material

3.1.1 Normal strength hull steels or equivalent grades are to be used for the test samples.

### 3.2 Filler metal

3.2.1 Approved filler metals are to be used.

3.2.2 Basic covered electrodes are to be used for manual metal arc welding.

### 3.3 Type and dimension of test samples

3.3.1 Test samples consist of double fillet welded T-joints formed by plates of the following dimensions:

300 mm x 120 mm x 15 mm for manual welding and semiautomatic bare wire and flux cored arc welding with gas shielding

### 3.4 Number of samples required

3.4.1 Two samples for each process are to be welded:

- a) manual metal arc welding with covered electrode of diameter 4 mm
- b) flux-cored wire metal arc welding with wire of diameter 1,2 mm
- c) solid wire metal arc welding with wire of diameter 1,2 mm.



**3.5 Preparation of test samples**

**3.5.1** The shop primer is to be applied in compliance with the manufacturer’s specifications.

The shop primer thickness (measure made on dry coat) of the test samples is to be at least 30% greater than the maximum foreseen in normal use.

**3.5.2** The pieces are to be tack welded such as to form a T with adherent contact between the surfaces, without gap.

For each test a), b) and c) described in [3.4.1], one sample is to be welded in horizontal-vertical position (PB), and the other in vertical upwards position (PF), using electrodes of diameter 4 mm and wire of diameter 1,2 mm. Welding is to be made in accordance with Welding Procedure Specification (WPS).

The fillet weld is to be deposited in one bead having dimensions not exceeding 7 mm x 7 mm as shown in Fig 1.

**Figure 1 : Typical T welded sample**

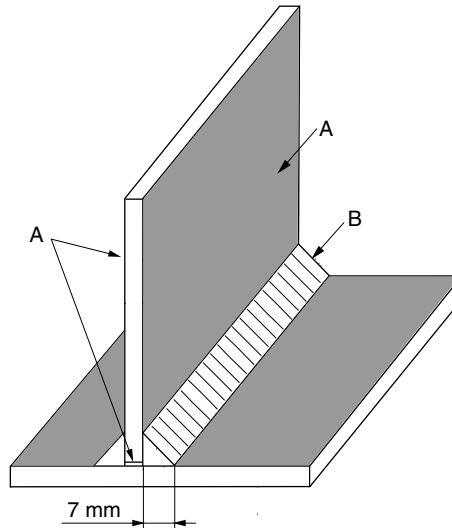

- A : Surfaces coated with the shop primer
- B : Weld bead

**3.6 Test requirements**

**3.6.1** The test sample is to be fractured by suitable means in order to locate the fracture in the throat of the fillet weld.

**3.6.2** Visual examination is to be carried out consisting of checking the external and fractured surface to determine weld penetration and presence of worm-holes, pores and other defects.

Possible defects located within 10 mm from the ends of the weld are disregarded.

Lack of penetration having total length not exceeding 1/4 of the weld length is accepted.

Wormholes and pores having diameter not exceeding 3mm are generally acceptable where the total area of porosity is not higher than 5% of the fracture section area.

**3.7 Re-tests**

**3.7.1** Where tests on one sample fails, re-tests on two samples for the same welding process are admitted.

Both test samples are to provide satisfactory results. Failing this, the shop primer is not approved.

**4 Certification**

**4.1 Certification**

**4.1.1** Subject to the satisfactory outcome of the required checks and tests, the Society will issue to the Manufacturer or supplier concerned the approval certificate for the shop primer.

**4.2 Renewal**

**4.2.1** In general, the approval certificate is issued for a five year period. For another five-year period, renewal survey is to be carried out by the Society. The manufacturer has to declare that no changes have been made to the production.

# Section 2 Side Scuttles, Windows and their Glass Panes

## 1 Requirements

### 1.1 Scope

1.1.1 The requirements of this Section apply to fixed frames, window frames, dead covers and glass panes.

The types of sidescuttles and windows which, in relation to their position, are to be tested are indicated in the Society's Rules.

### 1.2 Manufacture

#### 1.2.1 General

Sidescuttles and windows which are subject to inspection are to be manufactured in accordance with approved plans or standards and specifications recognised by the Society.

Manufacturing procedures are to be of appropriate type, to the Surveyor's satisfaction.

#### 1.2.2 Frame materials

Materials are to be of appropriate type and properties, as required in the approved plans or applicable standards.

They are to comply with the requirements of Chapter 3, Chapter 5, Chapter 6, Chapter 7, Chapter 8 and Chapter 9 in relation to the type of material and the nature of the product.

Subject to approval for each case or application, the following types of material and products are generally regarded as appropriate:

- hull steel plates, shapes and bars having  $R_m$  in the range 400-490 N/mm<sup>2</sup>
- steel forgings and castings
- brass plates, shapes, bars and castings
- light alloy castings and semi-finished products, of category Al-Mg or Al-Mg-Si.

Subject to approval in individual cases, nodular cast iron of type GS400 or GS370 may also be used.

#### 1.2.3 Glass panes

The glass panes are to be of appropriate type and quality, manufactured in accordance with suitable procedures, to the satisfaction of the Society, by recognized Manufacturers.

#### 1.2.4 Quality of materials

The product is to be free from detrimental defects.

### 1.3 Testing

#### 1.3.1 Frame material tests

Materials are to comply with the applicable requirements and are to be tested or certified accordingly; depending on the individual cases, they are also to be submitted to the following additional tests:

a) a bend test, as indicated below, depending on the type of material:

- brass products:  $d \leq 1 s$   $\alpha \geq 60^\circ$
- light alloy products:  $d \leq 3 s$   $\alpha \geq 60^\circ$
- cast iron:  $d \leq 4 s$   $\alpha \geq 60^\circ$

where:

$s$  : Thickness of the specimen (which, as far as possible, should be equal to the thickness of the product)

$d$  : Diameter of the mandrel

$\alpha$  : Required bend angle, which is to be attained without cracks or other defects.

b) for castings, as an alternative to the bend test performed on specimens, it may be agreed to perform a bend test directly on a completed piece. Such test may also be required by the Surveyor as an additional random check. When this test is performed as an alternative to that on specimens, the number of pieces tested is to be one for every batch of not more than 50 equal pieces (25 in the case of cast iron products) originating from the same heat.

These tests are to be performed on a mandrel having a diameter equal to twice the thickness of the piece (but not less than 50mm in the case of cast iron products); the required bend angles which are to be attained without cracks or other defects depending upon the material and the finished product are as follows:

- steel castings:  
fixed frames, window frames and dead covers:  $\alpha \geq 20^\circ$
- brass castings:  
fixed frames and window frames:  $\alpha \geq 10^\circ$   
dead covers:  $\alpha \geq 15^\circ$
- light alloy castings:  
fixed frames and window frames:  $\alpha \geq 6^\circ$   
dead covers:  $\alpha \geq 15^\circ$
- malleable or nodular cast iron:  $\alpha \geq 15^\circ$ .

### 1.3.2 Glass panes

Glass panes are to be in toughened safety glass in accordance with ISO 21005 standard. The acceptance of ordinary glass is subject to special approval by the Society in each case.

The glass Manufacturer is to certify the homogeneity of the batches submitted for tests, as regards material, manufacturing procedure, heat treatment and suitability to meet the specified test requirements.

Glass panes are to be tested as specified in the following items a) or b), and, c) if applicable.

- a) A hydrostatic test of one glass pane for each batch of 100 (or fraction of 100) glass panes equal in shape and dimensions and manufactured with continuity and using the same procedure and treatments; the pane is to be tested with a load uniformly distributed on the net area, at the test pressures indicated in Tab 1, in relation to the diameter and thickness of the pane.

The test pressure is to be applied for at least one minute; the glass pane is not to break.

In the case of glass panes having shape other than circular, the test is to be performed on a disk obtained from a glass pane for each batch homogeneous as regards dimensions, manufacturing procedure and heat treatment and with a total surface of 25m<sup>2</sup> or fraction thereof. The disk, for the test and possible re-tests, is to be taken before the tempering process and treated with the glass panes of the batch which it represents.

If a test produces unsatisfactory results, the test is to be repeated in duplicate on two new glass panes from the same batch; for the acceptance of the batch, both new tests are to be satisfactory; in the case of tempered glass panes of non-circular shape, in order not to have to reject the batch in the case of unsatisfactory test results, it is recommended that two additional disks should be taken for possible re-testing from the batch before the tempering treatment.

- b) A punch test in accordance with ISO 614 as an alternative to the hydrostatic test mentioned in a).

This test method is applicable both to non-opening and opening sidescuttles and rectangular windows; when tested, the glass edges are to be not less than 25mm from the inner edge of the rubber ring (see Fig 1).

The test consists of applying to the glass pane, which is supported by a steel plate with a circular hole, the required load through a rounded steel shaft acting along the centre of the hole.

The test is to be performed on 4 glass panes for each batch homogeneous as specified in a).

In the case of batches of 4 glass panes or less, the test is to be performed on each glass pane.

In the case of matt glass panes obtained by a special treatment of one of the surfaces of a transparent glass pane, the test is to be performed after the treatment and the load is to be applied to the surface which has not been treated.

The required test loads are indicated in Tab 2, in relation to the thickness of the glass pane and the diameter of the hole in the support plate.

The test is to be performed using the equipment and the procedure specified in ISO 614 Standard (see Fig 1).

- c) When flexural strength different from the one defined in the Society's Rules is used for the verification of minimum thickness of windows or side scuttles, the flexural strength of glass pane is to be determined according to ISO 1288-3 or another recognized standard.

Unless otherwise agreed, at least 10 specimens are to be tested. The accepted value is the one corresponding to the lower confidence interval value evaluated by the t\_Student distribution at 90% probability.

Note 1: Testing equipment

The equipment can be used for glass panes of sidescuttles having nominal diameter 200, 250 mm or greater and for glass of rectangular windows of any size.

The base of the testing equipment is formed by:

- a steel platform with upper flat surface provided with a 200 mm central hole with rounded edges (1);
- a rubber ring (2), having hardness in the range from 40 to 60 IRHD (International Rubber Hardness Degrees), with an inside diameter of 200 mm, thickness of 2 mm and width of at least 15 mm, located around the hole, between the steel plate and the glass pane, so as to compensate for any slight irregularities of the platform and to prevent the edges of the platform from bearing directly against the glass pane;
- a suitable adapter provided with a hole of 150 mm (6) with rounded edges, to be used when testing glass panes have a diameter of 200 mm (in these cases, a rubber ring (2) having an inside diameter of 150 mm is to be interposed between the upper surface of the adapter and the glass pane).

The glass pane to be tested (3) is positioned over the hole in the platform and a shaft (4) with a diameter of 50 mm and a fully rounded end is arranged above the glass pane along the axis of the hole.

A felt disk (5) having a thickness of 5mm is arranged between the shaft and the glass pane, for the purpose of distributing the load.

Note 2: Testing procedure

The applied load is to be increased at a rate of 1000 N per second up to the test load specified in Tab 2. The test load is to be maintained for a period of at least 5 seconds and is then to be removed gradually.

The glass panes are to withstand the required test load without fracture.

**Figure 1 : Testing apparatus for punch testing toughened glass panes**

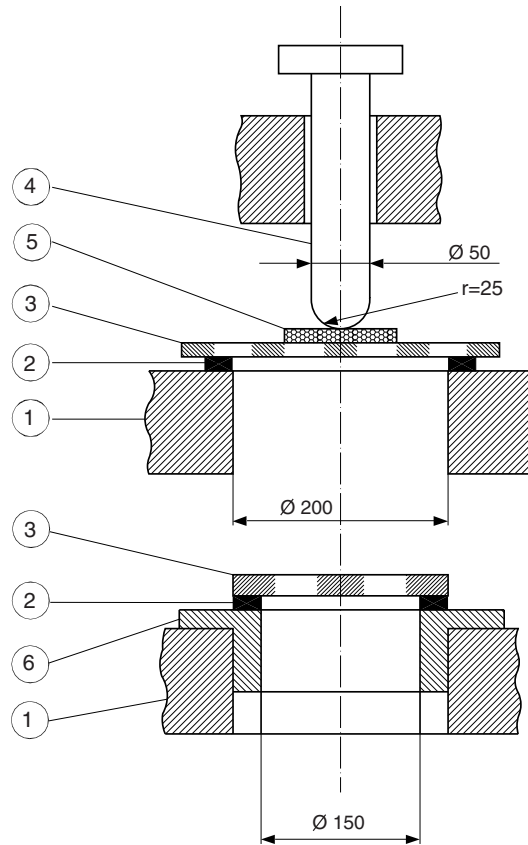

**Table 1 : Hydrostatic test pressure for glass panes of sidescuttles and windows**

Thickness of glass pane (mm)	Pressure (N/mm <sup>2</sup> ) for a glass pane net diameter (mm) of:					
	200	250	300	350	400	450
6	0,33	0,21	–	–	–	–
8	0,58	0,37	0,26	0,19	–	–
10	0,92	0,58	0,41	0,30	0,23	0,18
12	1,32	0,84	0,59	0,43	0,33	0,26
15	–	1,32	0,92	0,67	0,51	0,41
19	–	–	1,47	1,08	0,83	0,65

**Table 2 : Punch test load**

Thickness of glass pane (mm) (tolerance: 0 +2)	Test loads (N) for a hole diameter in support plate of:	
	200 mm	150 mm
6	3400	3500
8	6500	6700
10	10200	11000
12	15500	16500
15	24000	25500
19	33400	36800

### 1.3.3 Visual and dimensional examination

The following examinations are to be performed:

- a) visual examination
- b) dimensional and conformity checks to be performed by the Manufacturer, with checks at the discretion of the Surveyor.

### 1.4 Identification and marking

**1.4.1** All glass panes tested with satisfactory results are to be marked by the Manufacturer in a suitable position which remains clearly visible after the glass pane has been installed, as follows:

- trade mark and/or name of the Manufacturer
- Society's brand
- nominal thickness, in mm.

In the case of glass panes tested with the punch test, the special marking mentioned in ISO 614 is to be used as follows:

- transparent glass panes: single line triangle
- matt glass panes: double line triangle.

The nominal thickness of the glass pane, in mm, is to be marked inside the above triangles.

The markings identifying the origin of the glass pane are to be specified to the Society when the individual Manufacturers are recognised.

# Section 3 Pressure Bottles

## 1 Requirements

### 1.1 Scope

**1.1.1** The requirements of this Section apply to seamless pressure bottles in carbon, carbon manganese and alloy steels, and to welded bottles in carbon and carbon manganese steels.

Seamless bottles are mainly used for carbon dioxide systems and welded bottles for portable fire extinguishers.

Steel grades to be used for the manufacture are to comply with those specified in Chapter 3 as applicable or with recognised standards.

The steel is to be killed and for certain applications, for example low temperature applications, fine grained steel is to be used.

#### 1.1.2 Mass production

In the case of small bottles mass produced by Manufacturers who have been approved by the Society for this purpose, alternative testing procedures to those indicated in [1.3.2] may be accepted.

#### 1.1.3 Materials other than steel

The requirements relevant to bottles in material other than steel are to be considered on a case-by-case basis, with criteria and procedures as similar as possible to those specified in this Section.

### 1.2 Manufacture

**1.2.1** Bottles are to be manufactured according to approved plans.

The manufacturing process of seamless bottles is to be approved for the individual Manufacturers.

The approval of the manufacturing process is also required for welded bottles intended for portable fire extinguishers having thickness of the cylindrical shell less than 3 mm.

The materials used in the bottle manufacture are to be tested or provided with a Manufacturer's certificate of conformity.

### 1.3 Testing

**1.3.1** Reference is made to the general provisions given in Ch 1, Sec 1, [3.6] for visual, dimensional and non destructive examination.

#### 1.3.2 General

The following inspections and tests are to be performed:

- a) sectioning of one bottle from each batch formed of 200 pieces or fraction thereof, homogeneous as regards dimensions, manufacturing process and heat treatment for the execution of:
  - thickness measurements of the shell on three transverse sections in way of neck, middle and bottom end
  - 1 tensile test on longitudinal test specimen, 2 bending tests to be performed along the curvature and, for thicknesses  $\geq 5$  mm, 3 Charpy V-notch impact tests on longitudinal specimens, to be performed at  $-20^{\circ}\text{C}$ . For low temperature applications, the test temperature is to be specified in the individual cases.
- b) hardness tests to be performed on bottles of quenched and tempered steel and, at the discretion of the Surveyor, also in other cases
- c) external and internal visual examination (direct examination or, in the case of insufficient size of openings, examination by auxiliary means), dimensional check, determination of tare and capacity (such examinations are to be performed by the Manufacturer with checks at the Surveyor's discretion)
- d) hydrostatic test on each bottle; test pressure as required by the relevant Rules or by the particular requirements applicable in the individual cases
- e) non-destructive checks as indicated on the plans at the time of the approval of the manufacturing process
- f) for welded bottles, additional tests on welded joints as specified at the time of the approval of the manufacturing process or indicated on the approved plans.

#### 1.3.3 Tensile test

In the tensile test, the values of the yield strength  $R_{eH}$  and  $R_{p0.2}$ , the tensile strength  $R_m$  and the elongation  $A$  (%) are to comply with the values specified for the corresponding steel.

The value of A (%) min, for thicknesses equal to or greater than 3 mm, is to be not less than the value calculated with the following formula, and in no case less than 14%:

$$A \geq \frac{2500}{0,224 \cdot R_m}$$

where  $R_m$  is the value, in N/mm<sup>2</sup>, of the tensile strength determined by the tensile test.

This requirement for A (%) min may be reduced by 15% for thicknesses less than 3 mm down to 2 mm, and by 30% for thicknesses less than 2 mm.

**1.3.4 Bend test**

In the bending test, the angle to which the specimen is to be bent without showing defects is 180°; a mandrel having a diameter not exceeding “n” times the thickness of the specimen, depending on the minimum specified tensile strength  $R_m$  for the steel, as specified in Tab 1, is to be used.

**Table 1 : Coefficient n for determination of the maximum allowed mandrel diameter in bend test**

$R_m$ (N/mm <sup>2</sup> )	n
≤ 430	2
431 - 510	3
511 - 590	4
591 - 690	5
691 - 790	6
791 - 890	7
> 890	8

**1.3.5 Impact test**

In the Charpy V-notch impact test, the value of the absorbed energy, determined as an average of three tests, is to be not less than the value indicated in Tab 2 depending on the minimum tensile strength of the steel.

**Table 2 : Impact test - requirements**

Steel types	Tensile strength (N/mm <sup>2</sup> )	Average impact energy at -20°C min. KV (J/cm <sup>2</sup> )
Carbon and carbon- manganese	≤ 510	34
Alloy steels quenched and tempered	> 510	49

**1.4 Identification, marking and certification**

**1.4.1** The Manufacturer is to adopt a system of identification which will enable all finished bottles to be traced to the original materials and their manufacturing.

All bottles which have been tested and inspected with satisfactory results are to be marked with the following details:

- a) Manufacturer’s name or trade mark
- b) Society’s brand
- c) place and date of testing
- d) production number or other marking enabling the traceability
- e) test pressure
- f) additional optional marks such as file number and code of the local inspection office, Surveyor’s personal stamp.

Special marking and certification procedures may be agreed upon for supplies by Manufacturers granted the use of an alternative testing procedure.

**1.4.2** The testing documentation indicated in Ch 1, Sec 1, [4.2.1] is required and is to include all the information, as appropriate. The testing or works’ certificate of the material used is to be enclosed with the testing documentation.

Where applicable, the reports relevant to the non-destructive examination, pressure test and heat treatment are to be enclosed with the testing documentation.

**1.4.3** Before signing the Society’s inspection certificate, the Surveyor is to be provided by the Manufacturer with a written declaration stating that the bottles have been manufactured by a process approved by the Society, they comply with the applicable requirements and they have been satisfactorily tested in accordance with the Society’s Rules.

## CHAPTER 14

# ADVANCED NON-DESTRUCTIVE TECHNIQUES

---

### Section 1      Requirements



# Section 1 Requirements

## 1 Scope

### 1.1 General

**1.1.1** This Section gives minimum requirements on the methods and quality levels that are to be adopted for the advanced non-destructive testing (ANDT) of materials and welds during new building of ships. The advanced methods covered by this Section are listed in [1.3].

### 1.2 Weld joints

**1.2.1** This Section applies to butt welds with full penetration. Variations of joint design, for example, tee, corner and cruciform joints (with or without full penetration) can be tested using PAUT. The constraints of joint design with respect to testing are to be recognized, documented, and agreed with the Society before application.

### 1.3 Testing methods

**1.3.1** The methods mentioned in this Section for detection of imperfections are PAUT (only automated / semi-automated PAUT), TOFD, RT-D.

**1.3.2** Applicable methods for testing of the different types of materials and weld joints are given in Tab 1.

**Table 1 : Applicable methods for testing of materials and weld joints**

Materials and weld joints	Parent material thickness	Applicable methods
Ferritic butt welds with full penetration	thickness < 6 mm	RT-D
	6 mm ≤ thickness ≤ 40 mm	PAUT, TOFD, RT-D
	thickness > 40 mm	PAUT, TOFD, RT-D (1)
Ferritic tee joints and corner joints with full penetration	thickness ≥ 6 mm	PAUT, RT-D (1)
Ferritic cruciform joints with full penetration	thickness ≥ 6 mm	PAUT (1)
Austenitic stainless steel butt welds with full penetration (2)	thickness < 6 mm	RT-D
	6 mm ≤ thickness ≤ 40 mm	RT-D, PAUT (1)
	thickness > 40 mm	PAUT (1), RT-D (1)
Austenitic stainless steel tee joints, corner joints with full penetration (2)	thickness ≥ 6 mm	PAUT (1), RT-D (1)
Aluminum tee joints and corner joints with full penetration	thickness ≥ 6 mm	PAUT (1), RT-D (1)
Aluminum cruciform joints with full penetration	thickness ≥ 6 mm	PAUT (1)
Aluminum butt welds with full penetration	thickness < 6 mm	RT-D
	6 mm ≤ thickness ≤ 40 mm	RT-D, TOFD, PAUT
	thickness > 40 mm	TOFD, PAUT, RT-D (1)
Cast Copper Alloy	All	PAUT, RT-D (1)
Steel forgings	All	PAUT, RT-D (1)
Steel castings	All	PAUT, RT-D (1)
Base materials/Rolled steels, Wrought Aluminum Alloys	thickness < 6 mm	RT-D
	6 mm ≤ thickness ≤ 40 mm	PAUT, TOFD, RT-D
	thickness > 40 mm	PAUT, TOFD, RT-D (1)
(1) Only applicable with limitations, need special qualification subject to acceptance by the Society.		
(2) The ultrasonic testing of anisotropic material using advanced methods will require specific procedures and techniques. Additionally, the use of complementary techniques and equipment may also be required, e.g. using angle compression waves, and/or creep wave probes for detecting defects close to the surface.		

## 2 Acronyms

### 2.1 Definitions

**2.1.1** The following terms and definitions apply:

ANDT : Advanced non-destructive testing

RT-D : Digital Radiography

RT-S : Radioscopic testing with digital image acquisition (dynamic  $\geq 12$  bit)

RT-CR : Testing with computed radiography using storage phosphor imaging plates

PAUT : Phased Array Ultrasonic

TOFD : Time of Flight Diffraction

AUT : Automated Ultrasonic Examinations. A technique of ultrasonic examination performed with equipment and search units that are mechanically mounted and guided, remotely operated, and motor-controlled (driven) without adjustments by the technician. The equipment used to perform the examinations is capable of recording the ultrasonic response data, including the scanning positions, by means of integral encoding devices such that imaging of the acquired data can be performed.

SAUT : Semi-Automated Ultrasonic Examinations. A technique of ultrasonic examination performed with equipment and search units that are mechanically mounted and guided, manually assisted (driven), and which may be manually adjusted by the technician. The equipment used to perform the examinations is capable of recording the ultrasonic response data, including the scanning positions, by means of integral encoding devices such that imaging of the acquired data can be performed.

## 3 Supervision of personnel involved in ANDT operations

### 3.1 General requirements

**3.1.1** The Shipbuilder, manufacturer or its subcontractors shall have a supervisor or supervisors, responsible for the appropriate execution of ANDT operations and for the professional standard of the operators and their equipment, including the professional administration of the working procedures. The Shipbuilder, manufacturer or its subcontractors shall employ, on a full-time basis, at least one supervisor independently certified to Level 3 in the method(s) concerned as per the requirements of Ch 1, Sec 1, [3.6.5]. It is not permissible to appoint Level 3 personnel; they must be certified by an accredited certification body. It is recognised that a Shipbuilder, manufacturer or its subcontractors may not directly employ a Level 3 in all the stated methods practiced. In such cases, it is permissible to employ an external, independently certified, Level 3 in those methods not held by the full-time Level 3(s) of the Shipbuilder, manufacturer or its subcontractors.

The supervisor shall be directly involved in review and acceptance of ANDT Procedures, ANDT reports, calibration of ANDT equipment and tools. The supervisor shall on behalf of the Shipbuilder, manufacturer or its subcontractors re-evaluate the qualification of the operators annually.

## 4 Technique and procedure qualification

### 4.1 Documentation to be submitted

**4.1.1** The shipbuilder or manufacturer has to submit the following documentation to the Society for review:

- The technical documentation of the ANDT
- The operating methodology and procedure of the ANDT according to Article [7]
- Result of software simulation, when applicable

### 4.2 Software simulation

**4.2.1** Software simulation may be required by the Society, when applicable for PAUT or TOFD techniques. The simulation may include initial test set-up, scan plan, volume coverage, result image of artificial flaw etc.. In some circumstances, artificial defect modeling / simulation may be needed or required by the project.

### 4.3 Procedure qualification test

**4.3.1** The procedure qualification for ANDT system shall include the following steps:

- Review of available performance data for the inspection system (detection abilities and defect sizing accuracy).
- Identification and evaluation of significant parameters and their variability.
- Planning and execution of a repeatability and reliability test programme<sup>1</sup> which including on-site demonstration.
- Documentation of results from the repeatability and reliability test programs.

**4.3.2** The data from the repeatability and reliability test program is to be analysed with respect to comparative qualification block test report and on-site demonstration.

The qualification block shall be in accordance with ASME V Article 14 mandatory Appendix II “UT performance demonstration criteria” or agreed by the Society, and at least the intermediate level qualification blocks shall be used. The high level qualification blocks shall be used when sizing error distributions and an accurate PoD need to be evaluated. The demonstration process on-site shall be witnessed by the Society’s surveyor.

### 4.4 Procedure approval

**4.4.1** The testing procedure is to be evaluated based upon the qualification results, if satisfactory the procedure can be considered approved.

### 4.5 On-site review

**4.5.1** For the test welds, supplementary NDT shall be performed on an agreed proportion of welds to be cross checked with other methods. Alternatively, other documented reference techniques may be applied to compare with ANDT results.

Data analyses shall be performed in accordance with the above activities. Probability of Detection (PoD) and sizing accuracy shall be established when applicable.

When the result of inspection review does not conform to the approved procedure, the inspection shall be suspended immediately. Additional procedure review qualification and demonstration shall be undertaken to account for any nonconformity.

When a significant nonconformity is found, the Society has the right to reject the results of such activities.

## 5 Surface condition

### 5.1 Requirements

**5.1.1** Area to be examined shall be free from scale, loose rust, weld spatter, oil, grease, dirt or paint that might affect the sensitivity of the testing method.

**5.1.2** Where there is a requirement to carry out PAUT or TOFD through paint, the suitability and sensitivity of the test shall be confirmed through an appropriate transfer correction method defined in the procedure. In all cases, if transfer losses exceed 12dB, the reason shall be considered and further preparation of the scanning surfaces shall be carried out, if applicable. If testing is done through paint, then the procedure shall be qualified on a painted surface.

**5.1.3** The requirement for acceptable test surface finish is to ensure accurate and reliable detection of defects. For the testing of welds, where the test surface is irregular or has other features likely to interfere with the interpretation of ANDT results, the weld is to be ground or machined.

## 6 Testing requirements

### 6.1 General requirements

**6.1.1** The shipyard or manufacturer is to ensure that personnel carrying out ANDT or interpreting the results of ANDT are qualified to the appropriate level as detailed in Ch 1, Sec 1, [3.6.5].

**6.1.2** The following applies to testing procedures:

- a) All ANDT are to be carried out to a procedure that is representative of the item under inspection.
- b) Procedures are to identify the component to be examined, the ANDT method, equipment to be used and the full extent of the examinations including any test restrictions.
- c) Procedures are to include the requirement for components to be positively identified and for a datum system or marking system to be applied to ensure repeatability of inspections.
- d) Procedures are to include the method and requirements for equipment calibrations and functional checks, together with specific technique sheets / scan plans, for the component under test.
- e) Procedures are to be approved by personnel qualified to Level III in the appropriate technique in accordance with a recognised standard.
- f) Procedures are to be reviewed by the Society’s Surveyor.

**6.1.3** When using ultrasonics, depending on the complexity of the item under test and the access to surfaces, there may be a requirement for additional scans and/or complementary NDT techniques to ensure that full coverage of the item is achieved. PAUT of welds shall include a linear scan of the fusion face, together with other scans as defined in the specific test technique.

**6.1.4** As per this section, RT-D comprises of two main RT methods; RT-S and RT-CR. Other methods may be included (e.g. radioscopy systems), however, they are subject to special consideration on the basis of these requirements.

In all RT-D methods, in addition to specific requirements, detector output quality control methods shall be described within the procedure.

The procedure shall define the level of magnification, post-processing tools, image/data security and storage, for final evaluation and reporting.

**6.2 Phased array ultrasonic testing (PAUT)**

**6.2.1 Information required prior to testing**

PAUT shall be carried out according to procedures based on ISO 13588:2019, ISO 18563-1:2015, ISO 18563-2:2017, ISO 18563-3:2015 and ISO 19285:2017 or recognized standards accepted by the Society.

The PAUT procedure shall include the information shown in Tab 2.

When the specified value or range of values of an essential variable is modified, the PAUT procedure shall be requalified. A change of value or range of values of a non-essential variable does not require requalification. Any change of value or range of values specified in the PAUT procedure requires a revision of, or an addendum to, the PAUT procedure.

**Table 2 : Content of a PAUT procedure**

Requirement	Essential Variable	Nonessential Variable
Material types or weld configurations to be examined, including thickness dimensions and material product form (castings, forgings, pipe, plate, etc.)	X	–
The surfaces from which the examination shall be performed	X	–
Technique(s) (straight beam, angle beam, contact, and/or immersion)	X	–
Angle(s) and mode(s) of wave propagation in the material	X	–
Search unit type, frequency, element size and number, pitch and gap dimensions, and shape	X	–
Focal range (identify plane, depth, or sound path)	X	–
Virtual aperture size (i.e., number of elements, effective height <b>(1)</b> , and element width)	X	–
Focal laws for E-scan and S-scan (i.e., range of element numbers used, angular range used, element or angle increment change)	X	–
Special search units, wedges, shoes, or saddles, when used	X	–
Ultrasonic instrument(s)	X	–
Calibration (calibration block(s) and technique(s))	X	–
Directions and extent of scanning	X	–
Scanning (manual vs. automatic)	X	–
Method for sizing indications and discriminating geometric from flaw indications	X	–
Computer enhanced data acquisition, when used	X	–
Scan overlap (decrease only)	X	–
Personnel performance requirements, when required	X	–
Testing levels, acceptance levels and/or recording levels	X	–
Personnel qualification requirements	–	X
Surface condition (examination surface, calibration block)	–	X
Couplant (brand name or type)	–	X
Post-examination cleaning technique	–	X
Automatic alarm and/or recording equipment, when applicable	–	X
Records, including minimum calibration data to be recorded (e.g., instrument settings)	–	X
Environmental and safety issues	–	X
<b>(1)</b> Effective height is the distance from the outside edge of the first to last element used in the focal law.		

**6.2.2 Testing**

a) Testing levels

The testing levels specified in the testing procedure shall be in accordance with recognized standards accepted by the Society. Four testing levels are specified in ISO 13588:2019, each corresponding to a different probability of detection of imperfections.

b) Weld Examinations

The weld examinations shall be in accordance with ISO 13588:2019 and the additional requirements of this Section.

c) Volume to be inspected

The purpose of the testing shall be defined by the testing procedure. Based on this, the volume to be inspected shall be determined.

A scan plan shall be provided. The scan plan shall show the beam coverage, the weld thickness and the weld geometry.

If the evaluation of the indications is based on amplitude only, it is a requirement that an ‘E’ scan (or linear scan) shall be utilized to scan the fusion faces of welds, so that the sound beam is perpendicular to the fusion face  $\pm 5^\circ$ . This requirement may be omitted if an “S” (or sectorial) scan can be demonstrated to verify that discontinuities at the fusion face can be detected and sized, using the stated procedure (note, this demonstration shall utilize reference blocks containing suitable reflectors in location of fusion zone).

d) Reference blocks

Depending on the testing level, a reference block shall be used to determine the adequacy of the testing (e.g. coverage, sensitivity setting). The design and manufacture of reference blocks shall be in accordance with ISO 13588:2019 or equivalent block from recognized standards accepted by the Society.

e) Indication assessment

Indications shall be evaluated either by length and height or by length and maximum amplitude. Indication assessment shall be in accordance with ISO 19285:2017 or recognized standards accepted by the Society. The sizing techniques include reference levels, Time Corrected Gain (TCG), Distance Gain Size (DGS) and 6 dB drop. 6 dB drop method shall only be used for measuring the indications larger than the beam width.

**Table 3 : Content of a TOFD procedure**

Requirement	Essential Variable	Nonessential Variable
Weld configurations to be examined, including thickness dimensions and material product form (castings, forgings, pipe, plate, etc.)	X	–
The surfaces from which the examination shall be performed	X	–
Angle(s) of wave propagation in the material	X	–
Search unit type(s), frequency(ies), and element size(s)/shape(s)	X	–
Special search units, wedges, shoes, or saddles, when used	X	–
Ultrasonic instrument(s) and software(s)	X	–
Calibration (calibration block(s) and technique(s))	X	–
Directions and extent of scanning	X	–
Scanning (manual vs. automatic)	X	–
Data sampling spacing (increase only)	X	–
Method for sizing indications and discriminating geometric from flaw indications	X	–
Computer enhanced data acquisition, when used	X	–
Scan overlap (decrease only)	X	–
Personnel performance requirements, when required	X	–
Testing levels, acceptance levels and/or recording levels	X	–
Personnel qualification requirements	–	X
Surface condition (examination surface, calibration block)	–	X
Couplant (brand name or type)	–	X
Post-examination cleaning technique	–	X
Automatic alarm and/or recording equipment, when applicable	–	X
Records, including minimum calibration data to be recorded (e.g., instrument settings)	–	X
Environmental and safety issues	–	X

**6.3 Time of flight diffraction (TOFD)**

**6.3.1 Information required prior to testing**

TOFD shall be carried out according to procedure based on ISO 10863:2011, and ISO 15626:2018 or recognized standards accepted by the Society.

The PAUT procedure shall include the information shown in Tab 3.

When the specified value or range of values of an essential variable is modified, the TOFD procedure shall be requalified. A change of value or range of values of a non-essential variable does not require requalification. Any change of value or range of values specified in the TOFD procedure requires a revision of, or an addendum to, the TOFD procedure.

**Table 4 : Content of a digital radiography (RT-D) procedure**

Requirement:	
	Material types or weld configurations to be examined, including thickness dimensions and material product form (castings, forgings, pipe, plate, etc.)
Digitizing System Description:	
	Manufacturer and model no. of digitizing system
	Physical size of the usable area of the image monitor
	Film size capacity of the scanning device
	Spot size(s) of the film scanning system
	Image display pixel size as defined by the vertical/horizontal resolution limit of the monitor
	Illuminance of the video display
	Data storage medium
Digitizing Technique:	
	Digitizer spot size (in microns) to be used
	Loss-less data compression technique, if used
	Method of image capture verification
	Image processing operations
	Time period for system verification
Spatial resolution used:	
	Contrast sensitivity (density range obtained)
	Dynamic range used
	Spatial linearity of the system
	Material type and thickness range
	Source type or maximum X-ray voltage used
	Detector type
	Detector calibration
	Minimum source-to-object distance
	Distance between the test object and the detector
	Source size
	Test object scan plan (if applicable)
	Image Quality Measurement Tools
	Image Quality Indicator (IQI)
	Wire Image Quality Indicator
	Duplex Image Quality Indicator
	Image Identification Indicator
	Testing levels, acceptance levels and/or recording levels
	Personnel qualification requirements
	Surface condition
	Records, including minimum calibration data to be recorded
	Environmental and Safety issues

## 6.3.2 Testing

### a) Testing levels

The testing levels specified in the testing procedure shall be in accordance with recognized standards accepted by the Society. Four testing levels are specified in ISO 10863:2011, each corresponding to a different probability of detection of imperfections.

### b) Volume to be inspected

The purpose of the testing shall be defined by the testing procedure. Based on this, the volume to be inspected shall be determined.

A scan plan shall be provided. The scan plan shall show the locations of the probes, beam coverage, the weld thickness and the weld geometry.

### c) Due to the nature of the TOFD method, there is a possibility that the scan plan may reveal weld volume zones that will not receive full TOFD coverage (commonly known as dead zones, either in the lateral wave, back wall, or both). If the scan plan reveals that these dead zones are not adequately inspected, then further TOFD scans and/or complementary NDT methods shall be applied to ensure full inspection coverage.

## 6.4 Digital radiography (RT-D)

### 6.4.1 Testing levels

Digital radiography shall be performed per procedure(s) based on ISO 17636-2:2013 and standards referenced therein, or recognized standards accepted by the Society.

Any variation to the standard (e.g. IQI placement) shall be agreed with the Society.

The RT-D procedure shall include the information shown in Tab 4.

Reference is made to [7.4] for the choice of testing level as per ISO 17636-2:2013.

## 7 Acceptance levels

### 7.1 General requirements

7.1.1 This section details the acceptance levels for the assessment of the ANDT results.

7.1.2 It may be necessary to combine testing methods to facilitate the assessment of indications against the acceptance criteria.

7.1.3 Acceptance level for each application case shall be agreed with the Society in accordance with the concerned part of the rules.

### 7.2 Phased array ultrasonic testing (PAUT)

#### 7.2.1 Weld Examinations

The relationship between acceptance levels, testing levels and quality levels is given in Tab 5.

Quality levels and acceptance levels for PAUT of welds shall be in accordance with ISO19285:2017 or recognized standard agreed with the Society.

#### 7.2.2 Other application

Quality levels and acceptance levels for PAUT shall be agreed with the Society in accordance with recognized standards.

### 7.3 Time of flight diffraction (TOFD)

7.3.1 The relationship between acceptance levels, testing levels and quality levels is given in Tab 6.

Quality levels and acceptance levels for TOFD of welds shall be in accordance to ISO 15626:2018 or recognized standard agreed with the Society.

### 7.4 Digital radiography (RT-D)

7.4.1 The relationship between acceptance levels, testing levels and quality levels is given in Tab 7.

Quality levels and acceptance levels for Digital Radiography of welds shall be in accordance with ISO 10675 or recognized standard agreed with the Society.



**Table 5 : Acceptance levels for PAUT**

Quality levels according to ISO 5817:2014	Testing level according to ISO 13588:2019	Acceptance levels according to ISO 19285:2017
C, D	A	3
B	B	2
By agreement	C	1
Special application	D	By agreement

**Table 6 : Acceptance levels for TOFD**

Quality levels according to ISO 5817:2014	Testing level according to ISO 10863:2011	Acceptance level according to ISO 15626:2018
B (Stringent)	C	1
C (Intermediate)	At least B	2
D (Moderate)	At least A	3

**Table 7 : Acceptance levels for digital radiography (RT-D)**

Quality levels according to ISO 5817:2014 or ISO 10042:2018	Testing techniques / level (class) according to ISO 17636-2:2013	Acceptance level according to ISO 10675-1:2016 and ISO 10675-2:2017
B (Stringent)	B (class)	1
C (Intermediate)	B (1) (class)	2
D (Moderate)	A (class)	3
(1) For circumferential weld testing, the minimum number of exposures may correspond to the requirements of ISO 17636-2:2013, class A		

## 8 Reporting

### 8.1 Requirements

**8.1.1** The test report shall include the following information:

- a) reference of the standards used
- b) information relating to the object under test:
  - 1) identification of the object under test
  - 2) dimensions including wall thickness
  - 3) material type and product form
  - 4) geometrical configuration
  - 5) location of welded joint(s) examined
  - 6) reference to welding process and heat treatment
  - 7) surface condition and temperature
  - 8) stage of manufacture
- c) information relating to equipment (see Tab 8)
- d) information relating to test technology (see Tab 9)
- e) information relating to test results (see Tab 10).

**8.1.2** Results of ANDT are to be recorded and evaluated by the shipbuilder or manufacturer on a continual basis. These records are to be available to the Surveyor.

**8.1.3** The shipbuilder or manufacturer is to be responsible for the review, interpretation, evaluation and acceptance of the results of ANDT. Reports stating compliance or otherwise with the criteria established in the inspection procedure are to be issued.

**8.1.4** In addition to the above general reporting requirements, all specified ANDT methods will have particular requirements and details that shall be listed in the report.

**8.1.5** The shipbuilder or manufacturer is to keep the inspection records for at least 5 years.



**Table 8 : Information relating to equipment**

Method	Information
All	manufacturer and type of instrument, including with identification numbers if required
PAUT	a) manufacturer, type, frequency of phased array probes including number and size of elements, material and angle(s) of wedges with identification numbers if required b) details of reference block(s) with identification numbers if required c) type of couplant used
TOFD	a) manufacturer, type, frequency, element size and beam angle(s) of probes with identification numbers if required, b) details of reference block(s) with identification numbers if required, c) type of couplant used
RT-D	a) system of marking used, b) radiation source, type and size of focal spot and identification of equipment used, c) detector, screens and filters and detector basic spatial resolution

**Table 9 : Information relating to test technology**

Method	Information
All	a) testing level and reference to a written test procedure b) purpose and extent of test c) details of datum and coordinate systems d) method and values used for range and sensitivity settings e) details of signal processing and scan increment setting f) access limitations and deviations from standards, if any
PAUT	a) increment (E-scans) or angular increment (S-scans) b) element pitch and gap dimensions c) focus (calibration should be the same as scanning) d) virtual aperture size, i.e. number of elements and element width e) element numbers used for focal laws f) documentation on permitted wedge angular range from manufacturer g) documented calibration, TCG and angle gain compensation h) scan plan
TOFD	a) details of TOFD setups b) details of offset scans, if required
RT-D	a) detector position plan b) tube voltage used and current or source type and activity c) time of exposure and source-to-detector distance d) type and position of image quality indicators e) achieved and required SNRN for RT-S or achieved and required grey values and/or SNRN for RT-CR f) for RT-S: type and parameters such as gain, frame time, frame number, pixel size, calibration procedure g) for RT-CR: scanner type and parameters such as pixel size, scan speed, gain, laser intensity, laser spot size h) image-processing parameters used, e.g. of the digital filters

**Table 10 : Information relating to test results**

Method	Information
All	a) acceptance criteria applied b) tabulated data recording the classification, location and size of relevant indications and results of evaluation c) results of examination including data on software used d) date of test e) reference to the raw data file(s) f) date(s) of scan or exposure and test report g) names, signatures and certification of personnel
PAUT	a) phased array images of at least those locations where relevant indications have been detected on hard copy, all images or data available in soft format b) reference points and details of the coordinate system
TOFD	TOFD images of at least those locations where relevant TOFD indications have been detected

## **9 Unacceptable indications and repairs**

### **9.1 Requirements**

**9.1.1** All indications (discontinuities) exceeding the applicable acceptance criteria shall be classed as defects, and shall be eliminated and repaired as per the applicable part of the Society's Rules.



#### **BUREAU VERITAS MARINE & OFFSHORE**

Tour Alto  
4 place des Saisons  
92400 Courbevoie - France  
+33 (0)1 55 24 70 00

[marine-offshore.bureauveritas.com/rules-guidelines](https://marine-offshore.bureauveritas.com/rules-guidelines)

© 2024 BUREAU VERITAS - All rights reserved



**BUREAU  
VERITAS**

**Shaping a World of Trust**