



**BUREAU
VERITAS**

Approval of the Manufacturing Process of Metallic Materials

January 2021

**Rule Note
NR480 DT R05 E**



GENERAL CONDITIONS

1. INDEPENDENCE OF THE SOCIETY AND APPLICABLE TERMS

- 1.1 The Society shall remain at all times an independent contractor and neither the Society nor any of its officers, employees, servants, agents or subcontractors shall be or act as an employee, servant or agent of any other party hereto in the performance of the Services.
- 1.2 The operations of the Society in providing its Services are exclusively conducted by way of random inspections and do not, in any circumstances, involve monitoring or exhaustive verification.
- 1.3 The Society acts as a services provider. This cannot be construed as an obligation bearing on the Society to obtain a result or as a warranty. The Society is not and may not be considered as an underwriter, broker in Unit's sale or chartering, expert in Unit's valuation, consulting engineer, controller, naval architect, designer, manufacturer, shipbuilder, repair or conversion yard, charterer or shipowner; none of them above listed being relieved of any of their expressed or implied obligations as a result of the interventions of the Society.
- 1.4 The Society only is qualified to apply and interpret its Rules.
- 1.5 The Client acknowledges the latest versions of the Conditions and of the applicable Rules applying to the Services' performance.
- 1.6 Unless an express written agreement is made between the Parties on the applicable Rules, the applicable Rules shall be the Rules applicable at the time of entering into the relevant contract for the performance of the Services.
- 1.7 The Services' performance is solely based on the Conditions. No other terms shall apply whether express or implied.

2. DEFINITIONS

- 2.1 "Certificate(s)" means classification or statutory certificates, attestations and reports following the Society's intervention.
- 2.2 "Certification" means the activity of certification in application of national and international regulations or standards, in particular by delegation from different governments that can result in the issuance of a Certificate.
- 2.3 "Classification" means the classification of a Unit that can result or not in the issuance of a classification Certificate with reference to the Rules. Classification is an appraisal given by the Society to the Client, at a certain date, following surveys by its surveyors on the level of compliance of the Unit to the Society's Rules or to the documents of reference for the Services provided. They cannot be construed as an implied or express warranty of safety, fitness for the purpose, seaworthiness of the Unit or of its value for sale, insurance or chartering.
- 2.4 "Client" means the Party and/or its representative requesting the Services.
- 2.5 "Conditions" means the terms and conditions set out in the present document.
- 2.6 "Industry Practice" means international maritime and/or offshore industry practices.
- 2.7 "Intellectual Property" means all patents, rights to inventions, utility models, copyright and related rights, trade marks, logos, service marks, trade dress, business and domain names, rights in trade dress or get-up, rights in goodwill or to sue for passing off, unfair competition rights, rights in designs, rights in computer software, database rights, topography rights, moral rights, rights in confidential information (including know-how and trade secrets), methods and protocols for Services, and any other intellectual property rights, in each case whether capable of registration, registered or unregistered and including all applications for and renewals, reversions or extensions of such rights, and all similar or equivalent rights or forms of protection in any part of the world.
- 2.8 "Parties" means the Society and Client together.
- 2.9 "Party" means the Society or the Client.
- 2.10 "Register" means the public electronic register of ships updated regularly by the Society.
- 2.11 "Rules" means the Society's classification rules and other documents. The Society's Rules take into account at the date of their preparation the state of currently available and proven technical minimum requirements but are not a standard or a code of construction neither a guide for maintenance, a safety handbook or a guide of professional practices, all of which are assumed to be known in detail and carefully followed at all times by the Client.
- 2.12 "Services" means the services set out in clauses 2.2 and 2.3 but also other services related to Classification and Certification such as, but not limited to: ship and company safety management certification, ship and port security certification, maritime labour certification, training activities, all activities and duties incidental thereto such as documentation on any supporting means, software, instrumentation, measurements, tests and trials on board. The Services are carried out by the Society according to the applicable referential and to the Bureau Veritas' Code of Ethics. The Society shall perform the Services according to the applicable national and international standards and Industry Practice and always on the assumption that the Client is aware of such standards and Industry Practice.
- 2.13 "Society" means the classification society "Bureau Veritas Marine & Offshore SAS", a company organized and existing under the laws of France, registered in Nanterre under number 821 131 844, or any other legal entity of Bureau Veritas Group as may be specified in the relevant contract, and whose main activities are Classification and Certification of ships or offshore units.
- 2.14 "Unit" means any ship or vessel or offshore unit or structure of any type or part of it or system whether linked to shore, river bed or sea bed or not, whether operated or located at sea or in inland waters or partly on land, including submarines, hovercrafts, drilling rigs, offshore installations of any type and of any purpose, their related and ancillary equipment, subsea or not, such as well head and pipelines, mooring legs and mooring points or otherwise as decided by the Society.

3. SCOPE AND PERFORMANCE

- 3.1 Subject to the Services requested and always by reference to the Rules, the Society shall:
 - review the construction arrangements of the Unit as shown on the documents provided by the Client;
 - conduct the Unit surveys at the place of the Unit construction;
 - class the Unit and enter the Unit's class in the Society's Register;
 - survey the Unit periodically in service to note whether the requirements for the maintenance of class are met.The Client shall inform the Society without delay of any circumstances which may cause any changes on the conducted surveys or Services.
- 3.2 The Society will not:
 - declare the acceptance or commissioning of a Unit, nor its construction in conformity with its design, such activities remaining under the exclusive responsibility of the Unit's owner or builder;
 - engage in any work relating to the design, construction, production or repair checks, neither in the operation of the Unit or the Unit's trade, neither in any advisory services, and cannot be held liable on those accounts.

4. RESERVATION CLAUSE

- 4.1 The Client shall always: (i) maintain the Unit in good condition after surveys; (ii) present the Unit for surveys; and (iii) inform the Society in due time of any circumstances that may affect the given appraisal of the Unit or cause to modify the scope of the Services.
- 4.2 Certificates are only valid if issued by the Society.
- 4.3 The Society has entire control over the Certificates issued and may at any time withdraw a Certificate at its entire discretion including, but not limited to, in the following situations: where the Client fails to comply in due time with instructions of the Society or where the Client fails to pay in accordance with clause 6.2 hereunder.
- 4.4 The Society may at times and at its sole discretion give an opinion on a design or any technical element that would 'in principle' be acceptable to the Society. This opinion shall not presume on the final issuance of any Certificate or on its content in the event of the actual issuance of a Certificate. This opinion shall only be an appraisal made by the Society which shall not be held liable for it.

5. ACCESS AND SAFETY

- 5.1 The Client shall give to the Society all access and information necessary for the efficient performance of the requested Services. The Client shall be the sole responsible for the conditions of presentation of the Unit for tests, trials and surveys and the conditions under which tests and trials are carried out. Any information, drawing, etc. required for the performance of the Services must be made available in due time.
- 5.2 The Client shall notify the Society of any relevant safety issue and shall take all necessary safety-related measures to ensure a safe work environment for the Society or any of its officers, employees, servants, agents or subcontractors and shall comply with all applicable safety regulations.

6. PAYMENT OF INVOICES

- 6.1 The provision of the Services by the Society, whether complete or not, involve, for the part carried out, the payment of fees thirty (30) days upon issuance of the invoice.

6.2 Without prejudice to any other rights hereunder, in case of Client's payment default, the Society shall be entitled to charge, in addition to the amount not properly paid, interests equal to twelve (12) months LIBOR plus two (2) per cent as of due date calculated on the number of days such payment is delinquent. The Society shall also have the right to withhold Certificates and other documents and/or to suspend or revoke the validity of Certificates.

6.3 In case of dispute on the invoice amount, the undisputed portion of the invoice shall be paid and an explanation on the dispute shall accompany payment so that action can be taken to solve the dispute.

7. LIABILITY

- 7.1 The Society bears no liability for consequential loss. For the purpose of this clause consequential loss shall include, without limitation:
 - Indirect or consequential loss;
 - Any loss and/or deferral of production, loss of product, loss of use, loss of bargain, loss of revenue, loss of profit or anticipated profit, loss of business and business interruption, in each case whether direct or indirect.The Client shall defend, release, save, indemnify, defend and hold harmless the Society from the Client's own consequential loss regardless of cause.
- 7.2 Except in case of wilful misconduct of the Society, death or bodily injury caused by the Society's negligence and any other liability that could not be, by law, limited, the Society's maximum liability towards the Client is limited to one hundred and fifty per-cents (150%) of the price paid by the Client to the Society for the Services having caused the damage. This limit applies to any liability of whatsoever nature and howsoever arising, including fault by the Society, breach of contract, breach of warranty, tort, strict liability, breach of statute.
- 7.3 All claims shall be presented to the Society in writing within three (3) months of the completion of Services' performance or (if later) the date when the events which are relied on were first discovered by the Client. Any claim not so presented as defined above shall be deemed waived and absolutely time barred.

8. INDEMNITY CLAUSE

8.1 The Client shall defend, release, save, indemnify and hold harmless the Society from and against any and all claims, demands, lawsuits or actions for damages, including legal fees, for harm or loss to persons and/or property tangible, intangible or otherwise which may be brought against the Society, incidental to, arising out of or in connection with the performance of the Services (including for damages arising out of or in connection with opinions delivered according to clause 4.4 above) except for those claims caused solely and completely by the gross negligence of the Society, its officers, employees, servants, agents or subcontractors.

9. TERMINATION

- 9.1 The Parties shall have the right to terminate the Services (and the relevant contract) for convenience after giving the other Party thirty (30) days' written notice, and without prejudice to clause 6 above.
- 9.2 In such a case, the Classification granted to the concerned Unit and the previously issued Certificates shall remain valid until the date of effect of the termination notice issued, subject to compliance with clause 4.1 and 6 above.
- 9.3 In the event where, in the reasonable opinion of the Society, the Client is in breach, or is suspected to be in breach of clause 16 of the Conditions, the Society shall have the right to terminate the Services (and the relevant contracts associated) with immediate effect.

10. FORCE MAJEURE

- 10.1 Neither Party shall be responsible or liable for any failure to fulfil any term or provision of the Conditions if and to the extent that fulfilment has been delayed or temporarily prevented by a force majeure occurrence without the fault or negligence of the Party affected and which, by the exercise of reasonable diligence, the said Party is unable to provide against.
- 10.2 For the purpose of this clause, force majeure shall mean any circumstance not being within a Party's reasonable control including, but not limited to: acts of God, natural disasters, epidemics or pandemics, wars, terrorist attacks, riots, sabotages, impositions of sanctions, embargoes, nuclear, chemical or biological contaminations, laws or action taken by a government or public authority, quotas or prohibition, expropriations, destructions of the worksite, explosions, fires, accidents, any labour or trade disputes, strikes or lockouts.

11. CONFIDENTIALITY

- 11.1 The documents and data provided to or prepared by the Society in performing the Services, and the information made available to the Society, are treated as confidential except where the information:
 - is properly and lawfully in the possession of the Society;
 - is already in possession of the public or has entered the public domain, otherwise than through a breach of this obligation;
 - is acquired or received independently from a third party that has the right to disseminate such information;
 - is required to be disclosed under applicable law or by a governmental order, decree, regulation or rule or by a stock exchange authority (provided that the receiving Party shall make all reasonable efforts to give prompt written notice to the disclosing Party prior to such disclosure).
- 11.2 The Parties shall use the confidential information exclusively within the framework of their activity underlying these Conditions.
- 11.3 Confidential information shall only be provided to third parties with the prior written consent of the other Party. However, such prior consent shall not be required when the Society provides the confidential information to a subsidiary.
- 11.4 Without prejudice to sub-clause 11.1, the Society shall have the right to disclose the confidential information if required to do so under regulations of the International Association of Classifications Societies (IACS) or any statutory obligations.

12. INTELLECTUAL PROPERTY

- 12.1 Each Party exclusively owns all rights to its Intellectual Property created before or after the commencement date of the Conditions and whether or not associated with any contract between the Parties.
- 12.2 The Intellectual Property developed by the Society for the performance of the Services including, but not limited to drawings, calculations, and reports shall remain the exclusive property of the Society.

13. ASSIGNMENT

- 13.1 The contract resulting from these Conditions cannot be assigned or transferred by any means by a Party to any third party without the prior written consent of the other Party.
- 13.2 The Society shall however have the right to assign or transfer by any means the said contract to a subsidiary of the Bureau Veritas Group.

14. SEVERABILITY

- 14.1 Invalidity of one or more provisions does not affect the remaining provisions.
- 14.2 Definitions herein take precedence over other definitions which may appear in other documents issued by the Society.
- 14.3 In case of doubt as to the interpretation of the Conditions, the English text shall prevail.

15. GOVERNING LAW AND DISPUTE RESOLUTION

- 15.1 These Conditions shall be construed and governed by the laws of England and Wales.
- 15.2 The Parties shall make every effort to settle any dispute amicably and in good faith by way of negotiation within thirty (30) days from the date of receipt by either one of the Parties of a written notice of such a dispute.
- 15.3 Failing that, the dispute shall finally be settled under the Rules of Arbitration of the Maritime Arbitration Chamber of Paris ("CAMP"), which rules are deemed to be incorporated by reference into this clause. The number of arbitrators shall be three (3). The place of arbitration shall be Paris (France). The Parties agree to keep the arbitration proceedings confidential.

16. PROFESSIONAL ETHICS

- 16.1 Each Party shall conduct all activities in compliance with all laws, statutes, rules, economic and trade sanctions (including but not limited to US sanctions and EU sanctions) and regulations applicable to such Party including but not limited to: child labour, forced labour, collective bargaining, discrimination, abuse, working hours and minimum wages, anti-bribery, anti-corruption, copyright and trademark protection, personal data protection (<https://personaldataprotection.bureauveritas.com/privacypolicy>).
- Each of the Parties warrants that neither it, nor its affiliates, has made or will make, with respect to the matters provided for hereunder, any offer, payment, gift or authorization of the payment of any money directly or indirectly, to or for the use or benefit of any official or employee of the government, political party, official, or candidate.
- 16.2 In addition, the Client shall act consistently with the Bureau Veritas' Code of Ethics. <https://group.bureauveritas.com/group/corporate-social-responsibility>

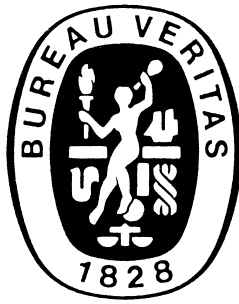

RULE NOTE NR 480

NR 480

Approval of the Manufacturing Process of Metallic Materials

Section 1 General

Section 2 Steelmaking and Rolled Steel Products

Section 3 Seamless Pipes and Fittings

Section 4 Welded Pipes and Fittings

Section 5 Steel Forgings

Section 6 Steel Castings

Section 7 Wrought Aluminium Alloy Products

Section 8 Explosion Bonded Aluminium/Steel Transition Joints

Section 9 Anchor Chain Cables and Accessories for Ships

Appendix 1 Evaluation of Kca

Appendix 2 Crack Arrest Temperature (CAT) Test

Section 1 General

1	General	7
1.1	Scope	
1.2	Request for approval	
1.3	Preliminary information to be submitted	
1.4	Approval test program	
1.5	Certification	
1.6	Renewal of approval	
1.7	Reconsideration of the approval	
1.8	Responsibilities of the manufacturer	

Section 2 Steelmaking and Rolled Steel Products

1	General	9
1.1	Scope	
1.2	Manufacturing process specification	
1.3	Documents to be submitted for changing the approval conditions	
1.4	Approval survey	
1.5	Position of the test samples	
1.6	Test specimens and testing procedure	
1.7	Other tests	
1.8	Results	
2	Semi finished products for hull structural steel grades	11
2.1	Scope	
2.2	Selection of the test product	
2.3	Extent of the approval tests	
2.4	Tests on semi finished products	
3	Rolled products made in normal and higher strength steel for hull and other structural applications	11
3.1	Scope	
3.2	Selection of the test product	
3.3	Extent of the approval tests	
3.4	Tests on rolled products	
3.5	Weldability tests	
4	Rolled products made in hull structural steel for high heat input welding	13
4.1	Scope	
4.2	Application of certification	
4.3	Confirmation tests	
4.4	Grade designation	
5	Rolled products made in normal and higher strength corrosion resistant steel for cargo oil tanks	15
5.1	Scope	
5.2	Manufacturing process specification	
5.3	Test program	
5.4	Corrosion tests	

6	Rolled products made in EH47 and crack arrest steels for container carriers	15
	6.1 Scope	
	6.2 Manufacturing process specification	
	6.3 Selection of the test product	
	6.4 Extent of the approval tests	
	6.5 Tests on rolled products	
	6.6 Crack arrest properties	
	6.7 Weldability tests	
7	Rolled products made of extra high strength steels for welded structure	18
	7.1 Scope	
	7.2 Manufacturing process specification	
	7.3 Selection of the test product	
	7.4 Extent of the approval tests	
	7.5 Tests on rolled products	
	7.6 Weldability tests	
8	Rolled products for boilers and pressure vessels	21
	8.1 Scope	
	8.2 Selection of the test product	
	8.3 Extent of the approval tests	
	8.4 Tests on rolled products	
	8.5 Weldability tests	
9	Rolled products made in ferritic steels for low temperature applications	23
	9.1 Scope	
	9.2 Selection of the test product	
	9.3 Extent of the approval tests	
	9.4 Tests on rolled products	
	9.5 Weldability tests	
10	Rolled products made in stainless steel	25
	10.1 Scope	
	10.2 Manufacturing process specification	
	10.3 Selection of the test product	
	10.4 Extent of the approval tests	
	10.5 Tests on rolled products for austenitic grades (304L, 316L, 316LN, 317L, 317LN)	
	10.6 Tests for austenitic-ferritic grades	
11	Round bars for anchor chain cables	27
	11.1 Scope	
	11.2 Selection of the test product	
	11.3 Extent of the approval tests	
	11.4 Tests on round bars	
12	Clad steel plates	28
	12.1 Scope	
	12.2 Manufacturing process specification	
	12.3 Selection of the test product	
	12.4 Extent of the approval tests	
	12.5 Tests on clad plate	

13	Plates with specified through thickness properties	29
	13.1 Scope	
	13.2 Manufacturing process specification	
	13.3 Selection of the test product	
	13.4 Extent of the approval tests	
	13.5 Tests on plates	

Section 3 Seamless Pipes and Fittings

1	Seamless pipes and fittings	30
	1.1 Scope	
	1.2 Approval Range	
	1.3 Manufacturing process specification	
	1.4 Documents to be submitted for changing the approval conditions	
	1.5 Approval survey	
	1.6 Approval test program	
	1.7 Approval tests	

Section 4 Welded Pipes and Fittings

1	Welded pipes and fittings	32
	1.1 Scope	
	1.2 Approval range	
	1.3 Manufacturing process specification	
	1.4 Documents to be submitted for changing the approval conditions	
	1.5 Approval survey	
	1.6 Approval test program	
	1.7 Approval tests	

Section 5 Steel Forgings

1	Steel forgings	34
	1.1 Scope	
	1.2 Approval range	
	1.3 Manufacturing process specification	
	1.4 Documents to be submitted for changing the approval conditions	
	1.5 Approval survey	
	1.6 Approval test program	
	1.7 Approval tests	

Section 6 Steel Castings

1	Steel castings	36
	1.1 Scope	
	1.2 Approval range	
	1.3 Manufacturing process specification	
	1.4 Documents to be submitted for changing the approval conditions	
	1.5 Approval survey	
	1.6 Approval test program	
	1.7 Approval tests	

Section 7 Wrought Aluminium Alloy Products

1	Wrought aluminium alloy products	38
1.1	Scope	
1.2	Manufacturing process specification	
1.3	Documents to be submitted for changing the approval conditions	
1.4	Approval survey	
1.5	Position of the test samples	
1.6	Test specimens and testing procedure	
1.7	Selection of the test product	
1.8	Extent of the approval tests	
1.9	Tests on base material	
1.10	Weldability tests	

Section 8 Explosion Bonded Aluminium/Steel Transition Joints

1	Explosion bonded aluminium/steel transition joints	41
1.1	Scope	
1.2	Manufacturing process specification	
1.3	Documents to be submitted for changing the approval conditions	
1.4	Approval survey	
1.5	Selection of the test product	
1.6	Extent of the approval tests	
1.7	Approval tests	
1.8	Other tests	

Section 9 Anchor Chain Cables and Accessories for Ships

1	Anchor chain cables and accessories for ships	43
1.1	Scope	
1.2	Manufacturing process specification	
1.3	Documents to be submitted for changing the approval conditions	
1.4	Approval survey	
1.5	Selection of the test product	
1.6	Extent of the approval tests	
1.7	Approval tests and documentation	

Appendix 1 Evaluation of Kca

1	Evaluation	47
1.1		

Appendix 2 Crack Arrest Temperature (CAT) Test

1	Scope of application	48
1.1		

2	Testing equipment	48
	2.1	
3	Test specimens	48
	3.1 Impact type crack initiation	
	3.2 Double tension type crack initiation	
	3.3 Embrittled zone setting	
	3.4 Side grooves	
	3.5 Nominal length of embrittled zone	
	3.6 Tab plate/pin chuck details and welding of test specimen to tab plates	
4	Test method	50
	4.1 Preloading	
	4.2 Temperature measurement and control	
	4.3 Loading and brittle crack initiation	
5	Measurements after test and test validation judgement	52
	5.1 Brittle crack initiation and validation	
	5.2 Crack path examination and validation	
	5.3 Fracture surface examination, crack length measurement and their validation	
6	Judgement of “arrest” or “propagate”	53
	6.1	
7	Ttest, Tarrest and CAT determination	53
	7.1 Ttest determination	
	7.2 Tarrest determination	
	7.3 CAT determination	
8	Reporting	54
	8.1	
9	Use of test for material qualification testing	54
	9.1	

SECTION 1

GENERAL

Symbols

A5%	: Elongation
AISI	: American Iron and Steel Institute
Ar ₃	: Temperature at which ferrite phase starts during cooling
ASSET test:	Visual Assessment of Exfoliation Corrosion Susceptibility of 5xxx Series Aluminium Alloys
ASTM	: American Society for Testing and Materials
CET	: Carbon equivalent
C _{EQ}	: Carbon equivalent
CR	: Controlled Rolling
CTOD	: Crack Tip Opening Displacement
CTS	: Controlled Thermal Severity
GB/T	: Chinese national standard
GCHAZ	: Grain Coarsened Heat Affected Zone
HAZ	: Heat Affected Zone
HV	: Hardness Vickers
IIW	: International Institute of Welding
ISO	: International Standard Organisation
JIS	: Japan Industrial Standard
Kca	: Brittle crack arrest toughness value
KS	: Korean Standard
KV	: Charpy V energy
N	: Normalised
NAMLT	: Nitric Acid Mass Loss Test
NDT	: Nil Ductility Temperature
NR	: Normalised Rolling
P _{cm}	: Parameter of crack measurement
PWHT	: Post Weld Heat Treatment
QT	: Quenched and Tempered
RA%	: Reduction of area
R _{eH}	: Yield stress
R _m	: Tensile strength
TM	: Thermo-mechanical Rolling
TM+AcC:	Thermo-mechanical Rolling follow by Accelerated Cooling
TM+DQ:	Thermo-mechanical Rolling with Direct Quenching follow by tempering
UNS	: Unified Numbering System.

1 General

1.1 Scope

1.1.1 This document gives the procedure to be followed to obtain the Society's approval certificate of material for manufacturing process of metallic products in accordance with NR216 Rules on Materials and Welding for the Classification of Marine Units.

Procedures for products and/or grades not explicitly included are subject to special examination by the Society.

1.2 Request for approval

1.2.1 The request for approval is to be submitted to the Society using the form obtained from BV office. In addition to the preliminary information mentioned in [1.3] as applicable, manufacturing process specification related to the products is to be submitted together with the request for approval.

1.3 Preliminary information to be submitted

1.3.1 Preliminary information to be submitted is to include:

- a) Name and site address of the manufacturer, location of the workshops, general indications relevant to the background, dimensions of the works, total annual production of finished products for marine applications and others as deemed useful
- b) Organization and quality
 - Organizational chart
 - Total number of staff
 - Organization of the quality control department and qualification of personnel involved
 - Certification of compliance of the quality system with ISO 9001, ISO 9002 or equivalent, if any.
- c) Manufacturing facilities
 - Flow chart of manufacturing process
 - Manufacturing equipments and capacities
 - Origin of raw materials
 - Storage of raw materials and finished products
 - Equipment for systematic control during manufacturing.

- d) Details of inspections and quality control facilities
 - How are materials and components identified at the various manufacturing stages
 - Equipment for chemical analysis, metallography, mechanical tests and relevant calibration procedures
 - Equipment for non-destructive examinations
 - List of quality control procedures.
- e) Approval(s) already granted by other Classification Societies and relevant approval test reports as deemed useful.

1.4 Approval test program

1.4.1 Unless otherwise agreed, the manufacturer shall submit for review an approval test program.

Typical approval programs for the various products are given in the relevant articles.

The approval tests are in general to be witnessed by the Society's surveyor at the manufacturer's works. If the testing facilities are not available at the manufacturer's works, the tests are to be carried out at recognised laboratories accepted by the Society, and, witnessed by the Society's surveyor.

1.5 Certification

1.5.1 Approval certificate

Upon satisfactory completion of the procedure, an approval certificate will be issued by the Society.

The validity of the approval is to be a maximum of five years.

1.5.2 List of approval certificates

The approval certificates issued to manufacturers are entered in a list containing the scope and the main conditions of approval available for consultation on the internet site "www.veristar.com".

1.6 Renewal of approval

1.6.1 The manufacturer shall apply for renewal of the approval certificate before the date of expiry. Renewal can be carried out by an audit and assessment of survey results, if satisfactory, during the period.

Manufacturers who have not produced the approved products during the period between renewals will be required to carry out approval tests or at the discretion of the Society, submit the results of production of similar products.

1.7 Reconsideration of the approval

1.7.1 During the period of validity, the approval may be reconsidered in the following cases:

- a) In service failures, traceable to product quality
- b) Major non conformity during testing of the product or non conformity revealed during fabrication and construction
- c) Breakdown of the Manufacturer's Quality System
- d) Changes brought by the Manufacturer, without preliminary agreement of the Society, to the extent of the approval defined at the time of the approval.

1.8 Responsibilities of the manufacturer

1.8.1 The Manufacturer is fully responsible for the quality of the finished product and ensuring compliance with the specified requirements, as checked on the specimens subjected to the approval tests.

The routine production of approved products shall be carried out according to the same procedures followed for the manufacture of specimens submitted to approval tests.

The manufacturer shall give prior warning to the Society of any significant modifications to the manufacturing and control procedures. The Society may at its discretion, require further tests and surveys deemed necessary to extend the approval to the new manufacturing conditions.

The manufacturer shall keep up-to-date records covering the manufacture and quality control of the products; the records shall contain details allowing the identification of the various productions, original materials, heat treatment and results of tests and examinations carried out. The Society's surveyor is to have easy access to these records as deemed necessary.

SECTION 2

STEELMAKING AND ROLLED STEEL PRODUCTS

1 General

1.1 Scope

1.1.1 This Section gives the approval scheme for steelmaking and rolling products made in hull structural steel grades, extra high strength steel grades, steel grades for boilers and pressure vessels, steel grades for low temperature applications, stainless steel grades and chain cable steel grades.

1.2 Manufacturing process specification

1.2.1 The following information is to be supplied by the manufacturer for all steel grades except for stainless steel grades (refer to [10]):

- a) Type of products (plates, sections, coils), grades of steel, range of thickness and aim material properties, as follows:
 - Range of chemical composition and aim analyses, including grain refining, micro alloying and residual elements, for the various grades of steel; if the range of chemical composition depends on thickness and supply condition, the different ranges are to be specified, as appropriate
 - Aim maximum carbon equivalent according to IIW formula
 - Aim maximum P_{cm} content for higher strength grades with low carbon content $C < 0,13\%$
 - Production statistics of the chemical composition and mechanical properties (R_{eH} , R_m , A% and KV). The statistics are intended to demonstrate the capability to manufacture the steel products in accordance with the requirements.
- b) Steelmaking
 - Steelmaking process and capacity of furnace(s) or converter(s)
 - Raw material used
 - Deoxidation and alloying practice
 - Desulphurisation and vacuum degassing installations, if any.
- c) Casting methods: ingot or continuous casting

In the case of continuous casting, information relevant to type of casting machine, teeming practice, methods to prevent re-oxidation, inclusions and segregation control, presence of electromagnetic stirring, soft reduction, etc., is to be provided as appropriate

 - Ingot or slab size and weight
 - Ingot or slab treatment: scarfing and discarding procedures.
- d) Reheating and rolling
 - Type of furnace and treatment parameters
 - Rolling: reduction ratio of slab/bloom/billet to finished product thickness, rolling and finishing temperatures
 - Descaling treatment during rolling
 - Capacity of the rolling stands.
- e) Heat treatment
 - Type of furnaces, heat treatment parameters and their relevant records
 - Accuracy and calibration of temperature control devices.
- f) Programmed rolling

For products delivered in the controlled rolling (CR) or thermo-mechanical rolling (TM) condition, the following additional information on the programmed rolling schedules is to be given:

 - Description of the rolling process
 - Normalizing temperature, re-crystallization temperature and Ar₃ temperature and the methods used to determine them
 - Control standards for typical rolling parameters used for the different thickness and grades of steel (temperature and thickness at the beginning and at the end of the passes, interval between passes, reduction ratio, temperature range and cooling speed of accelerated cooling, if any) and relevant method of control
 - Calibration of the control equipment.
- g) Recommendations for working and welding in particular for products delivered in the CR or TM condition
 - Cold and hot working recommendations if needed in addition to the normal practice used in the shipyards and workshops
 - Minimum and maximum heat input if different from the ones usually used in the shipyards and workshops (15 - 50 kJ/cm).
- h) Where any part of the manufacturing process is assigned to other companies or other manufacturing plants, additional information required by the Society is to be included.
- i) For the approval of the semi-finished products such as slabs, blooms and billets, the above information a), b) and c) is to be given.

1.3 Documents to be submitted for changing the approval conditions

1.3.1 The manufacturer has to submit to the Society the documents required in [1.2] together with the request of changing the approval conditions, in the case of the following a) through e):

- a) Change of the manufacturing process (steel making, casting, rolling and heat treatment)
- b) Change of the maximum thickness (dimension)
- c) Change of the chemical composition, added element, etc.
- d) Subcontracting the rolling, heat treatment, etc.
- e) Use of the slabs, blooms and billets manufactured by other companies which are not approved.

However, where the documents are duplicated by the ones at the previous approval for the same type of product, part or all of the documents may be omitted except the approval test program.

1.4 Approval survey

1.4.1 The approval tests are to be witnessed by the Surveyor at the manufacturer's plant and the execution of the plant inspection in operation may be required by the Surveyor during the visit for the approval.

If the testing facilities are not available at the works, the tests are to be carried out at laboratories accepted by the Society.

1.5 Position of the test samples

1.5.1 The test samples are to be taken, unless otherwise agreed, from the product (plate, flat, section, bar) corresponding to the top of the ingot, or, in the case of continuous casting, a random sample.

The position of the samples to be taken in the length of the rolled product, and the direction of the test specimens with respect to the final direction of rolling of the material are indicated in the relevant table for the material.

The position of the samples in the width of the product is to be in compliance with NR216 Materials and Welding, Ch 2, Sec 1, [1.8].

1.6 Test specimens and testing procedure

1.6.1 The test specimens and testing procedures are to be in accordance with NR216 Materials and Welding, Ch 1, Sec 2, unless agreed otherwise.

In particular the following applies:

- a) Tensile test
 - For plates made from hot rolled strip one additional tensile specimen is to be taken from the middle of the strip constituting the coil

- For plates having thickness greater than 40 mm, when the capacity of the available testing machine is insufficient to allow the use of test specimens of full thickness, multiple flat specimens, representing collectively the full thickness, can be used. Alternatively two round specimens with the axis located at one quarter and at mid-thickness can be taken.

b) Impact test

- For plates made from hot rolled strip one additional set of impact specimens is to be taken from the middle of the strip constituting the coil
- For plates having thickness greater than 40 mm one additional set of impact specimens is to be taken with the axis located at mid-thickness
- In addition to the determination of the energy value (Joule), the lateral expansion and the percentage crystallinity are to be reported for each specimen.

c) Chemical composition

In general the content of the following elements is to be checked: C, Mn, Si, P, S, Ni, Cr, Mo, Al, N, Nb, V, Cu, As, Sn, Ti and, for steel manufactured from electric or open-hearth furnace, Sb and B. The material for the check analysis should be taken from the tensile test specimen. Both the ladle and product analysis are to be reported.

d) Sulphur prints

Sulphur prints are to be taken from plate edges which are perpendicular to the axis of the ingot or slab.

They are to be approximately 600 mm long taken from the centre of the edge selected, i.e. on the ingot centre-line, and are to include the full plate thickness.

e) Micrographic examination

The micrographs are to be representative of the full thickness. For thick products in general at least three examinations are to be made at surface, one quarter and mid-thickness of the product.

All photomicrographs are to be taken at x100 magnification and where ferrite grain size exceeds ASTM 10, additionally at x500 magnification. Where applicable, ferrite grain size should be determined for each photomicrograph.

f) Drop weight test

When required the test is to be performed in accordance with ASTM E208. The Nil Ductility Transition temperature (NDT) is to be determined and photographs of the tested specimens are to be taken and enclosed with the test report.

The test results are to be in accordance, where applicable, with the requirements specified for the different steel grades in NR216 Materials and Welding, Ch 2, Sec 1.

1.7 Other tests

1.7.1 Additional tests such as CTOD test, large scale brittle fracture tests (Double Tension test, ESSO test, Deep Notch test, etc) or other tests may be required in the case of newly developed type of steel, outside the scope of NR216 Materials and Welding, Ch 2, Sec 1, [2], or when deemed necessary by the Society.

1.8 Results

1.8.1 All the results, which are to comply with the requirements of NR216 Materials and Welding, are evaluated for the approval; depending on the results, particular limitations or testing conditions, as deemed appropriate, may be specified in the approval document.

All the information required under [1.2], applicable to the products submitted to the tests, is to be collected by the manufacturer and put in the technical documentation which will include all the results of the tests and operation records relevant to steel making, casting, rolling and heat treatment of the test products.

2 Semi finished products for hull structural steel grades

2.1 Scope

2.1.1 This Article specifies the scheme for the approval of the manufacturing process of semi finished products such as ingots, slabs, blooms and billets for the hull structural steels.

2.2 Selection of the test product

2.2.1 For each grade of steel and for each manufacturing process (e.g. steel making, casting, rolling and condition of supply), one test product with the maximum thickness and one test product with the minimum thickness to be approved are in general to be selected for each kind of product (ingots, slabs, blooms/billets).

The selection of the casts for the test product is to be based on the typical chemical composition, with particular regard to the specified C_{EQ} or Pcm values and grain refining micro-alloying additions.

2.3 Extent of the approval tests

2.3.1 The extent of the test program is specified in [2.4]; it may be modified on the basis of the preliminary information submitted by the manufacturer.

In particular a reduction of the indicated number of casts, product thicknesses and grades to be tested or complete suppression of the approval tests may be accepted by the Society taking into account:

- Approval already granted by other Classification Societies and documentation of approval tests performed.
- Grades of steel to be approved and availability of long term statistic results of chemical properties and of mechanical tests performed on rolled products.
- Change of the approval conditions.

On the other hand, an increase of the number of casts and thicknesses to be tested may be required in the case of newly developed types of steel or manufacturing processes.

Where the number of tests differs from those shown in [2.4], the program is to be confirmed by the Society before the tests are carried out.

2.4 Tests on semi finished products

2.4.1 Type of tests

The tests to be carried out for the approval of the manufacturing process of semi finished products are:

- Chemical analysis. The analysis is to be complete and is to include micro-alloying elements
- Sulphur prints.

In addition, for initial approval and for any upgrade of the approval, the Society will require full tests indicated in this section to be performed at rolling mill on the minimum thickness semi finished product.

In case of multi-caster work, full tests on finished products shall be carried out for one caster and reduced tests (chemical analysis and sulphur print) for the others. The selection of the caster shall be based on the technical characteristics of the casters to be evaluated on case by case basis. Tests are to be performed at rolling mill on products manufactured from the minimum thickness semi finished product.

3 Rolled products made in normal and higher strength steel for hull and other structural applications

3.1 Scope

3.1.1 This Article gives the approval test program for the manufacture of normal and higher strength hull and structural steel products in groups A, B, D, E and AH32, DH32, EH32, FH32, AH36, DH36, EH36, FH36, AH40, DH40, EH40 and FH40.

3.2 Selection of the test product

3.2.1 For each grade of steel and for each manufacturing process (e.g. steel making, casting, rolling and condition of supply), one test product with the maximum thickness (dimension) to be approved is in general to be selected for each kind of product.

In addition, for initial approval, the Society will require selection of one test product of average thickness.

The selection of the casts for the test product is to be based on the typical chemical composition, with particular regard to the specified C_{EQ} or Pcm values and grain refining micro-alloying additions.

3.3 Extent of the approval tests

3.3.1 The extent of the test program is specified in [3.4] and [3.5]; it may be modified on the basis of the preliminary information submitted by the manufacturer.

In particular a reduction of the indicated number of casts, steel plate thicknesses and grades to be tested or complete suppression of the approval tests may be accepted by the Society taking into account:

- Approval already granted by other Classification Societies and documentation of approval tests performed.

- b) Grades of steel to be approved and availability of long term statistic results of chemical and mechanical properties.
- c) Approval for any grade of steel also covers approval for any lower grade in the same strength level, provided that the aim analysis, method of manufacture and condition of supply are similar.
- d) For higher tensile steels, approval of one strength level covers the approval of the strength level immediately below, provided the steelmaking process, deoxidation and fine grain practice, casting method and condition of supply are the same.
- e) Change of the approval conditions.
- f) Approval of the semi-finished products such as slabs, blooms and billets.

On the other hand, an increase of the number of casts and thicknesses to be tested may be required in the case of newly developed types of steel or manufacturing processes.

In case of multi-source slabs or changing of slab manufacturer, the rolled steel manufacturer is required to obtain the approval of the manufacturing process of rolled steels using the slabs from each slab manufacturer and to conduct approval tests in accordance with [3.4].

- The rolled steel manufacturer has already been approved for the manufacturing process using other semi finished products characterized by the same thickness, steel grade, grain refining and micro-alloying elements, steel-making and casting process
- The semi finished products manufacturer has been approved for the complete manufacturing process with the same conditions (steelmaking, casting, rolling and heat treatment) for the same steel types.

Where the number of tests differs from those shown in [3.4] and [3.5], the program is to be confirmed by the Society before the tests are carried out.

Table 1 : Tests on rolled products

Type of test		Position of the samples and direction of the test specimens (1)	Remarks				
Tensile test		Top and bottom - transverse (2)	R _{eH} , R _m , A5(%), RA(%) are to be reported				
Tensile test (stress relieved) only for TM steels		Top and bottom - transverse (2)	Stress relieving at 600°C (2 min/mm with minimum 1 hour)				
Impact test (3) on non aged specimens for grades:	A, B, AH32, AH36, AH40	Top and bottom - longitudinal	Testing temperature (°C):	+20	0	-20	
	D, DH32, DH36, DH40			0	-20	-40	
	E, EH32, EH36, EH40			0	-20	-40	-60
	FH32, FH36, FH40			-20	-40	-60	-80
	A, B, AH32, AH36, AH40	Top - transverse (4)	Testing temperature (°C):	+20	0	-20	
	D, DH32, DH36, DH40			0	-20	-40	
	E, EH32, EH36, EH40			-20	-40	-60	
	FH32, FH36, FH40			-40	-60	-80	
Impact test (3) on strain aged specimens (5) for grades:	AH32, AH36, AH40	Top - longitudinal	Testing temperature (°C):	+20	0	-20	
	D, DH32, DH36, DH40			0	-20	-40	
	E, EH32, EH36, EH40			-20	-40	-60	
	FH32, FH36, FH40			-40	-60	-80	
Chemical composition (6)		Top	Complete analysis including micro alloying elements				
Sulphur prints		Top					
Micro examination		Top					
Grain size determination		Top	Only for fine grain steels				
Drop weight test (4)		Top	Only for grades E, EH32, EH36, EH40, FH32, FH36, FH40 - Determination of NDT				
Through thickness tensile tests		Top and bottom	Only for grades with improved through thickness properties				
(1) For hot rolled strips, see [1.6].							
(2) Longitudinal direction for sections and plates having width less than 600 mm.							
(3) One set of 3 Charpy V-notch impact specimens is required for each impact test.							
(4) Not required for sections and plates having width less than 600 mm.							
(5) Deformation 5% + 1 hour at 250°C.							
(6) Besides product analyses, ladle analyses are required.							

3.4 Tests on rolled products

3.4.1 The tests to be carried out are indicated in Tab 1.

3.5 Weldability tests

3.5.1 General

Weldability tests are required for plates and are to be carried out on samples of the thickest plate.

Tests are required for normal strength grade E and for higher strength steels.

3.5.2 Preparation and welding of the test assemblies

The following tests are in general required:

- a) 1 butt weld test assembly welded with a heat input approximately 15 kJ/cm
- b) 1 butt weld test assembly welded with a heat input approximately 50 kJ/cm.

The butt weld test assemblies are to be prepared with the weld seam transverse to the plate rolling direction, so that impact specimens will result in the longitudinal direction.

The bevel preparation should be preferably 1/2V or K.

The welding procedure should be as far as possible in accordance with the normal welding practice used at the yards for the type of steel in question.

The welding parameters including consumables designation and diameter, pre-heating temperatures, interpass temperatures, heat input, number of passes, etc. are to be reported.

3.5.3 Type of tests

From the test assemblies the following test specimens are to be taken:

- a) One cross weld tensile test
- b) A set of 3 Charpy V-notch impact specimens transverse to the weld with the notch located at the fusion line and at a distance 2, 5 and minimum 20 mm from the fusion line. The fusion boundary is to be identified by etching the specimens with a suitable reagent. The test temperature is to be the one prescribed for the testing of the steel grade in question
- c) Hardness tests HV 5 across the weldment. The indentations are to be made along a 1 mm transverse line beneath the plate surface on both the face side and the root side of the weld as follows:
 - Fusion line
 - HAZ: at each 0,7 mm from fusion line into unaffected base material (6 to 7 minimum measurements for each HAZ)
 - The maximum hardness value should not be higher than 350 HV.

A sketch of the weld joint depicting groove dimensions, number of passes, hardness indentations should be attached to the test report together with photomicrographs of the weld cross section.

3.5.4 Other tests

Additional tests such as cold cracking tests (CTS, cruciform, implant, Tekken, bead on plate), CTOD, or other tests may be required in the case of newly developed type of steel, outside the scope of NR216 Materials and Welding, Ch 2, Sec 1, [2], or when deemed necessary by the Society.

4 Rolled products made in hull structural steel for high heat input welding

4.1 Scope

4.1.1 The application for weldability confirmation scheme is optional for manufacturers. The weldability confirmation scheme is intended to assess the weldability for high heat input welding under testing conditions.

This Article specifies the weldability confirmation scheme of normal and higher strength hull structural steel stipulated in [3] intended for welding with high heat input over 50kJ/cm.

Demonstration of conformance to the requirements of this document approves a particular steel mill to manufacture grade of steel to the specific chemical composition range, melting practice, and processing practice for which conformance was established. The approval scheme does not apply to qualification of welding procedures to be undertaken by the shipyards.

4.2 Application of certification

4.2.1 The manufacturer is to submit to the Society, request of certification, proposed weldability test program (see [4.3.2]) and technical documents relevant to:

- a) Outline of steel plate to be certified
 - Grade
 - Thickness range
 - Deoxydation practice
 - Fine grain practice
 - Aim range of chemical composition
 - Aim maximum C_{EQ} and P_{cm}
 - Production statistics of mechanical properties tensile and Charpy V-notch impact test, if any.
- b) Manufacturing control points to prevent toughness deterioration in heat affected zone when welded with high heat input, relevant to chemical elements, steelmaking, casting, rolling, heat treatment, etc.
- c) Welding control points to improve joint properties on strength and toughness, if any.

4.3 Confirmation tests

4.3.1 Range of certification

Range of certification for steel grades is to be the following a) through e) unless otherwise agreed by the Society:

- Approval tests on the lowest and highest toughness levels cover the intermediate toughness level
- Approval tests on normal strength cover that strength level only
- For high tensile steels, approval tests on one strength level cover strength level immediately below
- Tests may be carried out separately subject to the same manufacturing process
- Certification and documentation of confirmation tests performed by other Classification Societies may be accepted at the discretion of the Society.

4.3.2 Weldability test program

Extent of the test program is specified in [4.3.5] but it may be modified according to the content of certification. In particular, additional test assemblies and/or test items may be required in the case of newly developed type of steel, welding consumable and welding method, or when deemed necessary by the Society.

Where the content of tests differs from those specified in [4.3.5], the program is to be confirmed by the Society before the tests are carried out.

4.3.3 Test plate

Test plate is to be manufactured by a process approved by the Society in accordance with the requirements of [3].

For each manufacturing process route, two test plates with different thickness are to be selected. The thicker plate (t) and the thinner plate (less than or equal to t/2) are to be proposed by the manufacturer.

Small changes in manufacturing processing (e.g. within the TMCP process) may be considered for acceptance without testing, at the discretion of the Society.

4.3.4 Test assembly

One butt weld assembly welded with heat input over 50kJ/cm is to be generally prepared with the weld axis transverse to the plate rolling direction.

Dimensions of the test assembly are to be amply sufficient to take all the required test specimens specified in [4.3.5].

The welding procedures should be as far as possible in accordance with the normal practices applied at shipyards for the test plate concerned.

Welding process, welding position, welding consumable (manufacturer, brand, grade, diameter and shield gas) and welding parameters including bevel preparation, heat input, preheating temperatures, interpass temperatures, number of passes, etc. are to be reported.

4.3.5 Examinations and tests for the test assembly

The test assembly is to be examined and tested in accordance with the following a) through h) unless otherwise agreed by the Society:

- Visual examination: Overall welded surface is to be uniform and free from injurious defects such as cracks, undercuts, overlaps, etc.
- Macroscopic test: One macroscopic photograph is to be representative of transverse section of the welded joint and is to show absence of cracks, lack of penetration, lack of fusion and other injurious defects.
- Microscopic test: Along mid-thickness line across transverse section of the weld, one micrograph with x100 magnification is to be taken at each position of the weld metal centreline, fusion line and at a distance 2, 5, 10 and minimum 20 mm from the fusion line. The test result is provided for information purpose only.

- Hardness test: Along two line across transverse weld section 1 mm beneath plate surface on both face and root side of the weld, indentations by HV5 are to be made at weld metal centreline, fusion line and each 0,7 mm from fusion line to unaffected base metal (minimum 6 to 7 measurements for each heat affected zone).

The maximum hardness value should not be higher than 350 HV.

- Transverse tensile test: Two transverse (cross weld) tensile specimens are to be taken from the test assembly. Test specimens and testing procedures are to comply with the requirements of NR216 Materials and Welding, Ch 1, Sec 2.

The tensile strength is to be not less than the minimum required value for the grade of base metal.

- Bend test: Two transverse (cross weld) test specimens are to be taken from the test assembly and bent on a mandrel with diameter of quadruple specimen thickness. Bending angle is to be at least 120°. Test specimens are to comply with the requirements of NR216 Materials and Welding, Ch 1, Sec 2.

For plate thickness up to 20 mm, one face-bend and one root-bend specimens or two side-bend specimens are to be taken.

After testing, the test specimens shall not reveal any crack nor other open defect in any direction greater than 3 mm.

- Impact test: Charpy V-notch impact specimens (three specimens for one set) are to be taken within 2 mm below plate surface on face side of the weld with the notch perpendicular to the plate surface.

One set of the specimens transverse to the weld is to be taken with the notch located at the fusion line and at distance 2, 5 and minimum 20 mm from the fusion line. The fusion boundary is to be identified by etching the specimens with a suitable reagent. The test temperature is to be the one prescribed for the testing of the steel grade in question.

For steel plate with thickness greater than 50 mm or one side welding for plate thickness greater than 20 mm, one additional set of the specimens is to be taken from the root side of the weld with the notch located at each the same position as for the face side.

The average impact energy at the specified test temperature is to comply with NR216 Materials and Welding, Ch 2, Sec 1, Tab 4 and Ch 2, Sec 1, Tab 7 depending on the steel grade and thickness.

- h) Other test: Additional tests such as wide-width tensile test, HAZ tensile test, cold cracking tests (CTS, Cruciform, Implant, Tekken and Bead-on plate), CTOD or other tests should be required at the discretion of the Society (see [4.3.2]).

4.4 Grade designation

4.4.1 Upon issuance of the certificate, the notation indicating the value of heat input applied in the confirmation test may be added to the grade designation on the test plate, e.g. "EH36-W300" (in the case of heat input 300kJ/cm applied). The value of this notation is not to be less than 50 and every 10 added.

5 Rolled products made in normal and higher strength corrosion resistant steel for cargo oil tanks

5.1 Scope

5.1.1 This Article gives the scheme for the approval of the manufacturing process of normal and higher strength corrosion resistant steel products for cargo oil tanks.

The requirements of this Article are intended as a supplement to the requirements of Article [3], which specifies the test program for the manufacture of normal and higher strength hull and structural steel products.

5.2 Manufacturing process specification

5.2.1 In addition to the information mentioned in [1.2], the following information is to be submitted:

- a) Corrosion test plan and details of equipment and test environments
- b) Technical data related to the product assessment criteria for confirming corrosion resistance
- c) The technical background explaining how the variation in added and controlled elements improves corrosion resistance. The manufacturer will establish a relationship of all the chemical elements which affect the corrosion resistance, the chemical elements added or controlled to achieve this are to be specifically verified for acceptance. Verification is to be based on the ladle analysis of the steel
- d) The grades, the corrosion designation and maximum thickness of corrosion resistant steel to be approved
- e) The welding processes and the brand name of the welding consumables to be used for approval.

5.3 Test program

5.3.1 General

The extent of approval is to be as per [3.3] with the addition of corrosion test plan.

5.3.2 Corrosion test plan

The corrosion test plan is to be submitted by the manufacturer for review. If the test program is found satisfactory by the Society, it will be approved and returned to the manufacturer for acceptance prior to tests being carried out. Tests that need to be witnessed by the Surveyor will be identified.

The number of test samples is to be in accordance with the requirements of Appendix of the Annex to IMO MSC.289 (87) "Performance Standard for Alternative Means of Corrosion Protection for Cargo Oil Tanks of Crude Oil Tankers".

The number of casts and test samples selected are to be sufficient to make it possible to confirm the validity of interaction effects and/or the control range (upper limit, lower limit) of the elements which are added or intentionally controlled, for improving the corrosion resistance. Where agreed, this may be supported with data submitted by the manufacturer.

5.4 Corrosion tests

5.4.1 The corrosion tests are to be carried out in accordance with the approved test plan as per [5.3.2] and the corrosion testing procedure given in Appendix of the Annex to IMO MSC.289 (87) "Performance Standard for Alternative Means of Corrosion Protection for Cargo Oil Tanks of Crude Oil Tankers".

5.4.2 The Interpretation given in IACS UI SC258 on Test Procedures for Qualification of Corrosion Resistant Steel for Cargo Tanks in Crude Oil Tankers is to be applied.

6 Rolled products made in EH47 and crack arrest steels for container carriers

6.1 Scope

6.1.1 This Article gives the approval test program for the manufacture of steel products made of grades EH47, EH36CAS1, EH36CAS2, FH36CAS1, FH36CAS2, EH40CAS1, EH40CAS2, FH40CAS1, FH40CAS2, EH47CAS1 and EH47CAS2.

6.2 Manufacturing process specification

6.2.1 In addition to the information mentioned in [1.2], the following information is to be submitted for crack arrest steels:

- a) In-house test reports of the crack arrest properties of the steels intended for approval
- b) Approval test program for the crack arrest properties
- c) Production test procedure for the crack arrest properties

6.3 Selection of the test product

6.3.1 For each grade of steel and for each manufacturing process (e.g. steel making, casting, rolling and condition of supply), one test product with the maximum thickness (dimension) to be approved is in general to be selected for each kind of product.

In addition, for initial approval, the Society will require selection of one test product of average thickness.

The selection of the casts for the test product is to be based on the typical chemical composition, with particular regard to the specified C_{EQ} or Pcm values and grain refining micro alloying additions.

6.4 Extent of the approval tests

6.4.1 The extent of the test program is specified in [6.5] and [6.7]. It may be modified on the basis of the preliminary information submitted by the manufacturer.

In particular a reduction of the indicated number of casts, steel plate thicknesses and grades to be tested or complete suppression of the approval tests may be accepted by the Society, taking into account:

- Approval already granted by other Classification Societies and documentation of approval tests performed
- Grades of steel to be approved and availability of long term statistic results of chemical and mechanical properties
- Approval for any grade of crack arrest steel also covers approval for any lower grade in the same strength level, provided that the aim analysis, method of manufacture, mechanism to ensure the crack arrest properties and condition of supply are similar
- For crack arrest steels, approval of one strength level covers the approval of the strength level immediately below, provided the steelmaking process, deoxidation and fine grain practice, casting method, condition of supply and mechanism to ensure the crack arrest properties are same
- Change of the approval conditions
- Approval of the semi-finished products such as slabs, blooms and billets.

On the other hand, an increase of the number of casts and thicknesses to be tested may be required in the case of newly developed types of steel or manufacturing processes.

Where the number of tests differs from those shown in [6.5] and [6.7], the program is to be confirmed by the Society before the tests are carried out.

6.5 Tests on rolled products

6.5.1 The tests to be carried out are indicated in Tab 2.

6.6 Crack arrest properties

6.6.1 Crack arrest properties for crack arrest steels are to be verified by either the crack arrest toughness K_{ca} or Crack Arrest Temperature CAT.

6.6.2 In the case where the crack arrest properties are evaluated by K_{ca} , the crack arrest test method is to be in accordance with ISO 20064-2019. To obtain K_{ca} at a specific temperature the method specified in Annex B of ISO 20064-2019 can be used.

As a method for initiating a crack, a secondary loading mechanism (Double tension test) can also be used specified in Annex D of ISO 20064-2019.

The loading direction of crack arrest tests is to be parallel to the final rolling direction of the test plate.

The thickness of the test specimens of the crack arrest tests is to be the full thickness of the test plate.

The test specimens and repeat test specimens are to be taken from the same steel plate.

The evaluation of K_{ca} is to be in accordance to Appendix 1.

6.6.3 In the case where the crack arrest properties are evaluated by CAT, the test method is to be in accordance with Appendix 2.

6.7 Weldability tests

6.7.1 General

Weldability tests are required for plates and are to be carried out on samples of the thickest plate.

6.7.2 Preparation and welding of the test assemblies

The following tests are in general required:

- 1 butt weld test assembly welded with a heat input approximately 15 kJ/cm
- 1 butt weld test assembly welded with a heat input approximately 50 kJ/cm.

The butt weld test assemblies are to be prepared with the weld seam transverse to the plate rolling direction, so that impact specimens will result in the longitudinal direction.

The bevel preparation should be preferably 1/2V or K.

The welding procedure should be as far as possible in accordance with the normal welding practice used at the yards for the type of steel in question.

The welding parameters including consumables designation and diameter, pre-heating temperatures, interpass temperatures, heat input, number of passes, etc. are to be reported.

6.7.3 Type of tests

From the test assemblies the following test specimens are to be taken:

- One cross weld tensile test
- A set of 3 Charpy V-notch impact specimens transverse to the weld with the notch located at the fusion line and at a distance 2, 5 and minimum 20 mm from the fusion line. The fusion boundary is to be identified by etching the specimens with a suitable reagent.

Charpy V-notch impact tests are to be taken at a position of $\frac{1}{4}$ thickness from the plate surface on the face side of the weld with the notch perpendicular to the plate surface.

One additional set of specimens is to be taken from the root side of the weld with the notch located at the same position and at the same depth as for the face side.

The test temperature is to be the one prescribed for the testing of the steel grade in question.

Additionally, at each location impacts tests are to be carried out with appropriate temperature intervals to properly define the full transition range.

c) Hardness tests HV 5 across the weldment. The indentations are to be made along a 1 mm transverse line beneath the plate surface on both the face side and the root side of the weld as follows:

- Fusion line
- HAZ: at each 0,7 mm from fusion line into unaffected base material (6 to 7 minimum measurements for each HAZ)

- The maximum hardness value should not be higher than 350 HV.

A sketch of the weld joint depicting groove dimensions, number of passes, hardness indentations should be attached to the test report together with photomicrographs of the weld cross section.

d) Brittle fracture initiation test across the weldment

Deep notch test or CTOD test is to be carried out as per a recognized standard.

6.7.4 Other tests

Y-shape weld crack test is to be carried out.

The test method is to be in accordance with recognized standards such as JIS Z 3158-2016 or CB/T4364-2013.

Table 2 : Tests on rolled products

Type of test		Position of the samples and direction of the test specimen	Remarks				
Tensile test		Top and bottom - transverse (1)	R _{eH} , R _m , A5(%), RA(%) are to be reported				
Tensile test (stress relieved) only for TM steels		Top and bottom - transverse (1)	Stress relieving at 600°C (2 min/mm with minimum 1 hour)				
Impact test (2) on non aged specimens for grades	EH36CAS1, EH36CAS2, EH40CAS1, EH40CAS2, EH47, EH47CAS1, EH47CAS2	Top and bottom - longitudinal	Testing temperature (°C)	0	-20	-40	-60
	FH36CAS1, FH36CAS2, FH40CAS1, FH40CAS2			-20	-40	-60	-80
	EH36CAS1, EH36CAS2, EH40CAS1, EH40CAS2, EH47, EH47CAS1, EH47CAS2	Top - transverse (3)	Testing temperature (°C)	-20	-40	-60	
	FH36CAS, FH36CAS2, FH40CAS1, FH40CAS2			-40	-60	-80	
Impact test (2) on strain aged specimens (4) for grades	EH36CAS1, EH36CAS2, EH40CAS1, EH40CAS2, EH47, EH47CAS1, EH47CAS2	Top - longitudinal	Testing temperature (°C)	-20	-40	-60	
	FH36CAS1, FH36CAS2, FH40CAS1, FH40CAS2			-40	-60	-80	
Chemical composition (5)		Top	Complete analysis including micro alloying elements				
Sulphur prints		Top					
Micro examination		Top					
Grain size determination		Top					
Drop weight test (3)		Top	Determination of NDT				
Through thickness tensile tests		Top and bottom	Only for grades with improved through thickness properties				
Brittle fracture initiation test		Top	Deep notch test or CTOD test as per recognized standard				
Crack arrest test		Top - longitudinal	Except for grade EH47. Crack arrest properties evaluated by K _{ca} or CAT				
<p>(1) Longitudinal direction for plates having width less than 600 mm. (2) One set of 3 Charpy V-notch impact specimens is required for each impact test. (3) Not required for plates having width less than 600 mm. (4) Deformation 5% + 1 hour at 250°C. (5) Besides product analysis, ladle analyses are required.</p>							

7 Rolled products made of extra high strength steels for welded structure

7.1 Scope

7.1.1 This Article gives the approval test program for the manufacture of extra high strength steel products for welded structure made of grades A, B, D, E, F in the yield strength groups 420, 460, 500, 550, 620, 690, 890 and 960.

7.2 Manufacturing process specification

7.2.1 The following information is to be supplied by the manufacturer:

a) Type of products (plates, sections, bars and tubulars), grades of steel, range of thickness, delivery condition and aim material properties, as follows:

- Range of chemical composition, aim analyses and associated control limits, including grain refining, nitrogen binding, micro alloying and residual elements, for the various grades of steel; if the range of chemical composition depends on thickness and supply condition, the different ranges are to be specified, as appropriate.
- In addition, where zirconium, calcium and rare earth metals have been used during steelmaking for grain refinement and, or inclusion modification, the contents of these elements shall be specified in the approved specification.
- Aim carbon equivalent C_{EQ} according to IIW formula or CET formula and associated control limits.
- Aim Pcm content and associated control limits.
- Production statistics of the chemical composition and mechanical properties (R_{eH} , R_m , A5% and KV). The statistics are intended to demonstrate the capability to manufacture the steel products in accordance with the requirements.

b) Steelmaking

- Steelmaking process and capacity of furnace(s) or converter(s)
- Raw material used
- Deoxidation, grain refining, nitrogen binding and alloying practice
- Desulphurisation, dehydrogenation, sulphide treatment, ladle refining and vacuum degassing installations, if any.

c) Casting methods: ingot or continuous casting

In the case of continuous casting, information relevant to type of casting machine, teeming practice, methods to prevent re-oxidation, inclusions and segregation control, presence of electromagnetic stirring, soft reduction, etc., is to be provided as appropriate

- Casting/solidification cooling rate control
- Ingot or slab size and weight
- Ingot or slab treatment: scarfing and discarding procedures.

d) Reheating and rolling

- Type of furnace and treatment parameters

- Rolling: reduction ratio of ingot/slab/bloom/billet to finished product, rolling and finishing temperatures for each grade/thickness combination
- Descaling treatment during rolling
- Capacity of the rolling stands.

e) Heat treatment

- Type of furnaces, heat treatment parameters for products to be approved
- Accuracy and calibration of temperature control devices
- The method used to determine austenization temperature, re-crystallisation temperature and Ar3 temperature
- Description of quenching and tempering process, if applicable.

f) Programmed rolling

For products delivered in the normalised rolling (NR) or thermo-mechanical rolling (TM) condition, the following additional information on the programmed rolling schedules is to be given:

- Description of the rolling process
- Austenization temperature, re-crystallization temperature and Ar3 temperature and the methods used to determine them
- Control standards for typical rolling parameters used for the different thickness and grades of steel (temperature and thickness at the beginning and at the end of the passes, interval between passes, reduction ratio, temperature range and cooling speed of accelerated cooling, if any) and relevant method of control
- Calibration of the control equipment.

g) Recommendations for working and welding in particular for products delivered in the NR or TM condition

- Cold and hot working recommendations if needed in addition to the normal practice used in the shipyards and workshops
- Minimum and maximum heat input and recommended pre-heat/interpass temperature.

h) Where any part of the manufacturing process is assigned to other companies or other manufacturing plants, additional information required by the Society is to be included.

7.3 Selection of the test product

7.3.1 For each grade of steel and for each manufacturing process (e.g. steel making, casting, rolling and condition of supply), one test product with the maximum thickness (dimension) to be approved is in general to be selected for each kind of product.

In addition, for initial approval, the Society will require selection of one test product of representative thickness.

The selection of the casts for the test product is to be based on the typical chemical composition, with particular regard to the specified C_{EQ} , CET or Pcm values and grain refining micro-alloying additions.

7.4 Extent of the approval tests

7.4.1 The extent of the test program is specified in [7.5] and [7.6]; it may be modified on the basis of the preliminary information submitted by the manufacturer.

In particular a reduction of the indicated number of casts, steel plate thicknesses and grades to be tested or complete suppression of the approval tests may be accepted by the Society taking into account:

- Approval already granted by other Classification Societies and documentation of approval tests performed
- Grades of steel to be approved and availability of long term statistic results of chemical and mechanical properties
- Change of the approval conditions
- Approval of the semi-finished products such as slabs, blooms and billets.

On the other hand, an increase of the number of casts and thicknesses to be tested may be required in the case of newly developed types of steel or manufacturing processes.

In case of multi-source slabs or changing of slab manufacturer, the rolled steel manufacturer is required to obtain the approval of the manufacturing process of rolled steels using the slabs from each slab manufacturer and to conduct approval tests in accordance with [7.5] and [7.6].

- The rolled steel manufacturer has already been approved for the manufacturing process using other semi-finished products characterized by the same thickness, steel grade, grain refining and micro-alloying elements, steelmaking and casting process.
- The semi-finished products manufacturer has been approved for the complete manufacturing process with the same conditions (steelmaking, casting, rolling and heat treatment) for the same steel types.

Table 3 : Tests on rolled products

Type of test		Position of the samples and direction of the test specimens	Remarks				
Tensile test		Top and bottom - longitudinal and transverse	R_{eH} , R_m , A5(%), RA(%) and R_{eH}/R_m ratio are to be reported				
Impact tests (1) on non aged specimens for grades:	A420, A460, A500, A550, A620, A690, A890, A960	Top and bottom - longitudinal and transverse	Testing temperature (°C):	+20	0	-20	
	D420, D460, D500, D550, D620, D690, D890, D960			0	-20	-40	
	E420, E460, E500, E550, E620, E690, E890, E960			0	-20	-40	-60
	F420, F460, F500, F550, F620, F690			-20	-40	-60	-80
Impact test (1) on strain aged specimens (6) for grades:	A420, A460, A500, A550, A620, A690, A890, A960	Top and bottom - either longitudinal or transverse	Testing temperature (°C):	+20	0	-20	
	D420, D460, D500, D550, D620, D690, D890, D960			0	-20	-40	
	E420, E460, E500, E550, E620, E690, E890, E960			0	-20	-40	-60
	F420, F460, F500, F550, F620, F690			-20	-40	-60	-80
Chemical composition (2)		From top tensile specimen	Complete analysis including micro alloying elements, C_{EQ} /CET and Pcm value				
Segregation examination		Top	Sulphur prints (3)				
Micro examination		Top	At magnification 100 and 500				
Grain size determination		Top	Ferrite and/or prior austenite grain size should be determined				
Non-metallic inclusion contents/Cleanliness (4)		Top	ISO 4967 or other recognized standard				
Drop weight test (5)		Top	Determination of NDT				
Through thickness tensile test		Top and bottom	Only for grades with improved through thickness properties				
<p>(1) One set of 3 Charpy V-notch impact specimens is required for each impact test.</p> <p>(2) Besides product analysis, ladle analysis are required. The deviation of the product analysis from the ladle analysis shall be in accordance with the limits given in the manufacturing specification.</p> <p>(3) Other tests than sulphur prints for segregation examination may be agreed with the Society.</p> <p>(4) The level of non-metallic inclusions and impurities in term of amount, size, shape and distribution shall be controlled by the manufacturer. Alternative methods for demonstrating the non-metallic inclusions and impurities may be used by the manufacturer.</p> <p>(5) The test is to be performed only on plates.</p> <p>(6) Deformation 5% +1 hour at 250°C. Test is to be carried out on the thickest plate.</p>							

7.4.2 Where the number of tests differs from those shown in [7.5] and [7.6], the program is to be confirmed by the Society before the tests are carried out.

7.5 Tests on rolled products

7.5.1 The tests to be carried out are indicated in Tab 3.

7.5.2 Additional tests such as stress relieved tensile test (for TM steels), cold cracking tests (CTS, cruciform, implant, Tekken, bead on plate), CTOD test on parent plate, large scale brittle fracture tests (Double Tension test, ESSO test, Deep Notch test) or other tests may be required when deemed necessary by the Society.

7.6 Weldability tests

7.6.1 General

Weldability tests are required for plates and are to be carried out on samples of the thickest plate.

7.6.2 Butt weld test for steel strength levels 420 to 500 N/mm²

Testing on higher grades can cover the lower strength and toughness grades.

The following butt weld tests are required:

- a) 1 butt weld test assembly welded with the heat input 15 ± 2 kJ/cm is to be tested as-welded
- b) 1 butt weld test assembly welded with the heat input 50 ± 5 kJ/cm for N/NR and TM steels and $35 \pm 3,5$ kJ/cm for QT steels is to be tested as-welded
- c) 1 butt weld test assembly welded with the same heat input as given in b) is to be postweld heat treated (PWHT) prior to testing. Postweld heat treatment procedure is specified in [7.6.6].

Option: steels intended to be designated as steels for high heat input welding are to be tested with 1 butt weld test assembly in the as-welded condition and 1 butt weld test assembly in the post weld heat treated (PWHT) condition, both welded with the maximum heat input being approved.

7.6.3 Butt weld test for steel strength levels 550 to 960 N/mm²

Approval tests on the highest toughness grade cover approval for any lower grade in the same strength level, provided that the aim analysis, method of manufacture and condition of supply are similar.

The following butt weld tests are required:

- a) 1 butt weld test assembly welded with the heat input 10 ± 2 kJ/cm is to be tested as-welded
- b) 1 butt weld test assembly welded with the maximum heat input as proposed by the manufacturer is to be tested as-welded. The approved maximum heat input shall be stated on the manufacturer approval certificate.

Option: If the manufacturer requests to include the approval for post weld heat treated (PWHT) condition, 1 additional butt weld test assembly welded with a maximum heat input proposed by the manufacturer for the approval same as test

assembly b) is to be post-weld heat treated (PWHT) prior to testing. Postweld heat treatment procedure is specified in [7.6.6].

7.6.4 Butt weld test assembly

The butt weld test assemblies of N/NR plates are to be prepared with the weld seam transverse to the final rolling direction.

The butt weld test assemblies of TM, TM+AcC, TM+DQ and QT plates are to be prepared with the weld seam parallel to the final plate rolling direction. The butt weld test assemblies of long products, sections and seamless tubular in any delivery condition are to be prepared with the weld seam transverse to the rolling direction.

7.6.5 Bevel preparation

The bevel preparation should be preferably 1/2V or K depending of the thickness.

The welding procedure should be as far as possible in accordance with the normal welding practice used at the yards for the type of steel in question.

The welding parameters including consumables brand name, designation and diameter, pre-heating temperatures, interpass temperatures, heat input, number of passes, etc. are to be reported.

7.6.6 Post-weld heat treatment

- a) Steels delivered in N, NR or TM, TM+AcC, TM+DQ condition shall be heat treated for a minimum time of 1 hour per 25mm thickness (but not less than 30 minutes and needs not be more than 150 minutes) at a maximum holding temperature of 580°C, unless otherwise approved at the time of approval.
- b) Steels delivered in QT condition shall be heat treated for a minimum time of 1 hour per 25 mm thickness (but not less than 30 minutes and needs not be more than 150 minutes) at a maximum holding temperature of 550°C with the maximum holding temperature of at least 30°C below the previous tempering temperature, unless otherwise approved at the time of approval
- c) For all delivery condition, heating and cooling above 300°C shall be carried out in a controlled manner in order to heat/cool the material uniformly. The cooling rate from the maximum holding temperature to 300°C shall not be slower than 55°C/hr.

7.6.7 Type of tests

From the test assemblies the following test specimens are to be taken:

- a) One cross weld tensile test. One full thickness test sample or sub-sized samples cover the full thickness cross section.
- b) A set of 3 Charpy V-notch impact specimens transverse to the weld with the notch located at the fusion line and at a distance 2, 5 and minimum 20 mm from the fusion line. The fusion boundary is to be identified by etching the specimens with a suitable reagent.

Charpy V-notch impact specimens are to be taken at 1-2 mm below the surface on the face side of the weld with the notch perpendicular to the plate surface.

Figure 1 : CTOD test specimen geometry

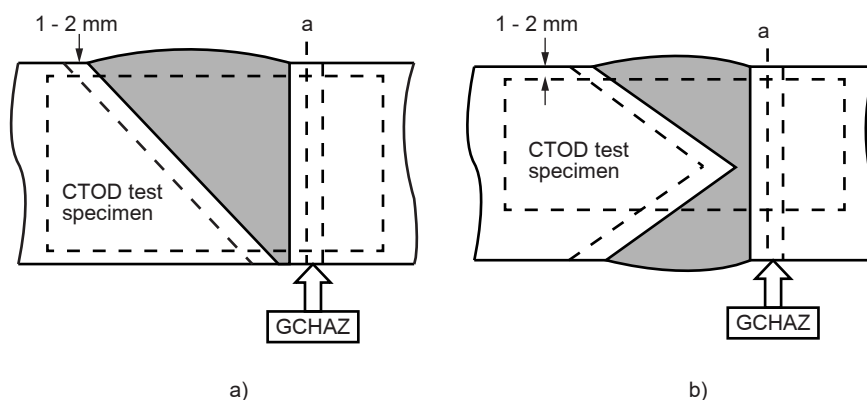

a) For plate thickness ≤ 50 mm, CTOD test specimen is to be sampled in full thickness.

b) For plate thickness > 50 mm, subsidiary test specimen with thickness of maximum 50mm in subsurface area is to be sampled.

One additional set of specimens is to be taken from the root side of the weld with the notch located at the same position and at the same depth as for the face side for plate with thickness 50mm and above.

The test temperature is to be the one prescribed for the testing of the steel grade in question.

c) Hardness tests HV 10 across the weldment.

The indentations are to be made along a 1 - 2 mm transverse line beneath the plate surface on both the face side and the root side of the weld as follows:

- Fusion line
- HAZ: at each 0,7 mm from fusion line into unaffected base material (6 to 7 minimum measurements for each HAZ)
- The maximum hardness value should not be higher than: 350 HV for steel strength levels 420 to 460N/mm²; 420 HV for steel strength levels 500 to 690N/mm²; 450 HV for steel strength levels 890 and 960N/mm².

A sketch of the weld joint depicting groove dimensions, number of passes, hardness indentations should be attached to the test report together with photomicrographs of the weld cross section.

d) Brittle fracture initiation test across the weldment.

CTOD tests are to be carried out for butt weld test assembly specified in [7.6.2] b) and [7.6.3] b) in accordance with EN ISO 15653 or other recognized standard.

- The specimen geometry (B=W) is permitted for plate thickness up to 50mm. For plate thicker than 50mm, subsidiary specimen geometry (50x50mm) is permitted, which is to be taken 50mm in depth through thickness from the subsurface and 50mm in width. See Fig 1 for more details.
- The specimens shall be notched in through thickness direction
- Grain-coarsened HAZ (GCHAZ) shall be targeted for the sampling position of the crack tip

- The test specimens shall be in as-welded and post-weld heat treated, if applicable
- Three tests shall be performed at -10°C on each butt weld test assembly.

For steel strength level 690N/mm² and above, dehydrogenation of as-welded test pieces may be carried out by a low temperature heat treatment, prior to CTOD testing. Heat treatment conditions of 200°C for 4h are recommended, and the exact parameters shall be notified with the CTOD test results.

e) Y-shape weld crack test (Hydrogen crack test) is to be carried out.

The test method is to be in accordance with recognized standards such as KS B0870, JIS Z 3158, GB/T4675.1 or ISO 17642-2.

Minimum preheat temperature is to be determined and the relationship of minimum preheat temperature with thickness is to be derived.

8 Rolled products for boilers and pressure vessels

8.1 Scope

8.1.1 This Article gives the approval test program for the manufacture of carbon manganese steel products made of grades (360HA, 360HB, 360HD, 410HA, 410HB, 410HD, 460HB, 460HD, 510HB, 510HD) and low alloy steel grades (0,3Mo - 1Cr0,5Mo - 2,25Cr1Mo) for boilers and pressure vessels.

8.2 Selection of the test product

8.2.1 For each grade of steel and for each manufacturing process (e.g. steel making, casting, rolling and condition of supply), two products (one per cast) from two different casts representing average and maximum thickness (dimension) to be approved are in general to be selected for each kind of product.

An additional product from another cast is to be tested for grades intended for application at elevated temperatures (boilers).

The selection of the casts for the test product is to be based on the typical chemical composition, with particular regard to the specified C_{EQ} or Pcm values and grain refining micro-alloying additions.

8.3 Extent of the approval tests

8.3.1 The extent of the test program is specified in [8.4] and [8.5]; it may be modified on the basis of the preliminary information submitted by the manufacturer.

In particular a reduction of the indicated number of casts, steel plate thicknesses and grades to be tested or complete suppression of the approval tests may be accepted by the Society taking into account:

- a) Approval already granted by other Classification Societies and documentation of approval tests performed.
- b) Grades of steel to be approved and availability of long term statistic results of chemical and mechanical properties.

- c) Approval for any grade of steel also covers approval for any lower grade in the same strength level, provided that the aim analysis, method of manufacture and condition of supply are similar.
- d) Approval of one yield strength level covers the approval of the yield strength level immediately below, provided the steelmaking process, deoxidation and fine grain practice, casting method and condition of supply are the same.
- e) Change of the approval conditions.
- f) Approval of the semi-finished products such as slabs, blooms and billets.

On the other hand, an increase of the number of casts and thicknesses to be tested may be required in the case of newly developed types of steel or manufacturing processes. Where the number of tests differs from those shown in [8.4] and [8.5], the program is to be confirmed by the Society before the tests are carried out.

8.4 Tests on rolled products

8.4.1 The tests to be carried out are indicated in Tab 4.

Table 4 : Tests on rolled products

Type of test		Position of the samples and direction of the test specimens (1)	Remarks				
Tensile test		Top and bottom - transverse (2)	R_{eH} , R_m , A5(%), RA(%) are to be reported				
Tensile test (stress relieved) only for CR or TM+AcC steels		Top and bottom - transverse (2)	Stress relieving at 600 °C (2 min/mm with minimum 1 hour)				
Tensile test at elevated temperature (grades intended for applications at elevated temperature)	360, 410, 460, 510	Top - transverse	Testing temperature (°C)	+100 or +150 mini.	interm. temp	+400	
	Low alloy grades			+200 mini.		maximum of the range	
Impact tests (3) on non aged specimens for grades:	360HA, 410HA	Top and bottom - longitudinal and transverse	Testing temperature (°C)	+20	0		
	360HB, 410HB, 460HB, 510HB			+20	0	-20	
	360HD, 410HD, 460HD, 510HD			+20	0	-20	-40
	Low alloy grades			+20	0		
Impact test (3) on strain aged specimens (5) for grades:	360HA, 410HA	Top and bottom - transverse	Testing temperature (°C)	+20			
	360HB, 410HB, 460HB, 510HB			+20	0		
	360HD, 410HD, 460HD, 510HD			+20	0	-20	
	Low alloy grades			0			
Chemical composition		From top tensile specimen	Complete analysis including micro alloying elements				
Sulphur prints		Top					
Micro examination		Top					
Drop weight test (4)		Top	Determination of NDT				
<p>(1) For hot rolled strips see [1.6].</p> <p>(2) Longitudinal direction for sections and plates having width less than 600 mm.</p> <p>(3) One set of 3 Charpy V-notch impact specimens is required for each impact test.</p> <p>(4) Not required for sections and plates having width less than 600 mm.</p> <p>(5) Deformation 5% + 1 hour at 250°C.</p>							

8.5 Weldability tests

8.5.1 General

Weldability tests are required for plates and are to be carried out on samples of the thickest plate.

8.5.2 Preparation and welding of the test assemblies

The following tests are in general required:

- a) 1 butt weld test assembly welded with a heat input equal to the minimum heat input recommended by the steelmaker
- b) 1 butt weld test assembly welded with a heat input equal to the maximum heat input recommended by the steelmaker.

The butt weld test assemblies are to be prepared with the weld seam parallel to the plate rolling direction, so that impact specimens will result in the transverse direction.

The bevel preparation should be preferably 1/2V or K depending on the thickness.

The welding procedure should be as far as possible in accordance with the normal welding practice used at the manufacturing shop for the type of steel in question.

The welding parameters including consumables brand name, designation and diameter, pre-heating temperatures, interpass temperatures, heat input, number of passes, etc. are to be reported.

8.5.3 Type of tests

From the test assemblies the following test specimens are to be taken:

- a) One cross weld tensile test
- b) A set of 3 Charpy V-notch impact specimens transverse to the weld with the notch located at the fusion line and at a distance 2, 5 and minimum 20 mm from the fusion line. The fusion boundary is to be identified by etching the specimens with a suitable reagent. The test temperature is to be the one prescribed for the testing of the steel grade in question. The minimum average impact energy shall exceed 27 J for carbon-manganese steels and 31 J for low alloy steels.
- c) Hardness tests HV 5 across the weldment. The indentations are to be made along a 1 mm transverse line beneath the plate surface on both the face side and the root side of the weld as follows:
 - Weld metal, at each 2 mm
 - Fusion line
 - HAZ: at each 0,5 mm from fusion line into unaffected base material
 - The maximum hardness value should not be higher than 320 HV.

A sketch of the weld joint depicting groove dimensions, number of passes, hardness indentations should be attached to the test report together with photomicrographs of the weld cross section.

Where a stress relieving treatment is required, cross weld tensile and Charpy V-notch impact tests are to be repeated in the stress relieved conditions.

8.5.4 Other tests

Additional tests such as cold cracking tests (CTS, cruciform, implant, Tekken, bead on plate), CTOD, or other tests may be required when deemed necessary by the Society.

9 Rolled products made in ferritic steels for low temperature applications

9.1 Scope

9.1.1 This Article gives the approval test program for the manufacture of ferritic steel products for low temperature applications including carbon manganese steels grade LE or LF in the tensile strength groups 410, 460, 510 and 550 and nickel steels grade 1,5Ni - 3,5Ni - 5,0Ni and 9,0Ni.

9.2 Selection of the test product

9.2.1 For each grade of steel and for each manufacturing process (e.g. steel making, casting, rolling and condition of supply), two products (one per cast) from two different casts representing average and maximum thickness (dimension) to be approved are in general to be selected for each kind of product.

The selection of the casts for the test product is to be based on the typical chemical composition, with particular regard to the specified C_{EQ} or Pcm values and grain refining micro-alloying additions.

9.3 Extent of the approval tests

9.3.1 The extent of the test program is specified in [9.4] and [9.5]; it may be modified on the basis of the preliminary information submitted by the manufacturer.

In particular a reduction of the indicated number of casts, steel plate thicknesses and grades to be tested or complete suppression of the approval tests may be accepted by the Society taking into account:

- a) Approval already granted by other Classification Societies and documentation of approval tests performed.
- b) Grades of steel to be approved and availability of long term statistic results of chemical and mechanical properties.
- c) Approval for any grade of steel also covers approval for any lower grade in the same strength level, provided that the aim analysis, method of manufacture and condition of supply are similar.
- d) Approval of one yield strength level covers the approval of the yield strength level immediately below, provided the steelmaking process, deoxidation and fine grain practice, casting method and condition of supply are the same.
- e) Change of the approval conditions.
- f) Approval of the semi-finished products such as slabs, blooms and billets.

On the other hand, an increase of the number of casts and thicknesses to be tested may be required in the case of newly developed types of steel or manufacturing processes.

Table 5 : Tests on rolled products

Type of test		Position of the samples and direction of the test specimens (1)	Remarks					
Tensile test		Top and bottom - transverse (2)	R _{eH} , R _m , A5(%), RA(%) are to be reported					
Impact tests (3) on non aged specimens for grades:	410LE, 460LE, 510LE, 560LE	Top and bottom - longitudinal and transverse	Testing temperature (°C):	0	-20	-40	-60	
	410LF, 460LF, 510LF, 560LF			0	-20	-40	-60	-80
	1,5Ni			-40	-60	-80	-100	
	3,5Ni			-60	-80	-100	-120	
	5,0Ni			-80	-100	-120	-196	
	9,0Ni			-80	-100	-163	-196	
Impact test (3) on strain aged specimens (5) for grades:	410LE, 460LE, 510LE, 560LE	Top and bottom - longitudinal and transverse	Testing temperature (°C):		-20	-40		
	410LF, 460LF, 510LF, 560LF					-40	-60	
	1,5Ni				-60	-80		
	3,5Ni				-80	-95		
	5,0Ni			-80	-110			
	9,0Ni					-163	-196	
Chemical composition		From top tensile specimen	Complete analysis including micro alloying elements					
Sulphur prints		Top						
Micro examination		Top						
Drop weight test (4)		Top	Determination of NDT					
<p>(1) For hot rolled strips see [1.6].</p> <p>(2) Longitudinal direction for sections and plates having width less than 600 mm.</p> <p>(3) One set of 3 Charpy V-notch impact specimens is required for each impact test.</p> <p>(4) Not required for sections and plates having width less than 600 mm.</p> <p>(5) Deformation 5% + 1 hour at 250°C.</p>								

Where the number of tests differs from those shown in [9.4] and [9.5], the program is to be confirmed by the Society before the tests are carried out.

9.4 Tests on rolled products

9.4.1 The tests to be carried out are indicated in Tab 5.

9.5 Weldability tests

9.5.1 General

Weldability tests are required for plates and are to be carried out on samples of the thickest plate.

9.5.2 Preparation and welding of the test assemblies

The following tests are in general required:

- 1 butt weld test assembly welded with a heat input equal to the minimum heat input recommended by the steelmaker
- 1 butt weld test assembly welded with a heat input equal to the maximum heat input recommended by the steelmaker.

The butt weld test assemblies are to be prepared with the weld seam parallel to the plate rolling direction, so that impact specimens will result in the transverse direction.

The bevel preparation should be preferably 1/2V or K depending on the thickness.

The welding procedure should be as far as possible in accordance with the normal welding practice used at the yards for the type of steel in question.

The welding parameters including consumables brand name, designation and diameter, pre-heating temperatures, interpass temperatures, heat input, number of passes, etc. are to be reported.

9.5.3 Type of tests

From the test assemblies the following test specimens are to be taken:

- One cross weld tensile test
- A set of 3 Charpy V-notch impact specimens transverse to the weld with the notch located at the fusion line and at a distance 1, 3, 5, 7 and minimum 20 mm from the fusion line. The fusion boundary is to be identified by etching the specimens with a suitable reagent. The test temperature is to be the one prescribed for the testing of the steel grade in question. The minimum average impact energy shall exceed 27 J

- c) Hardness tests HV 5 across the weldment. The indentations are to be made along a 1 mm transverse line beneath the plate surface on both the face side and the root side of the weld as follows:
- weld metal, at each 2 mm
 - fusion line
 - HAZ: at each 0,5 mm from fusion line into unaffected base material.
- d) The maximum hardness value should not be higher than:
- 320 HV for carbon manganese, 1,5Ni and 3,5Ni steels
 - 400HV for 5,0Ni and 9,0Ni steel grades.

A sketch of the weld joint depicting groove dimensions, number of passes, hardness indentations should be attached to the test report together with photomicrographs of the weld cross section.

Where a stress relieving treatment may be needed (plates with thickness above 50 mm), cross weld tensile and Charpy V-notch impact tests are to be repeated in the stress relieved conditions.

9.5.4 Other tests

Additional tests such as cold cracking tests (CTS, cruciform, implant, Tekken, bead on plate), CTOD, or other tests may be required when deemed necessary by the Society.

10 Rolled products made in stainless steel

10.1 Scope

10.1.1 This Article gives the approval test program for the manufacture of austenitic and austenitic-ferritic stainless steel products from AISI grades 304L, 304LN, 316L, 316LN, 317L, 317LN and UNS grades 31803, 32550 and 32750 used for the building of chemical tankers.

10.2 Manufacturing process specification

10.2.1 The following information is to be supplied by the manufacturer:

- a) Type of products, (plates, sections, coils), steel grades, range of thickness and aim material properties as follows:
- Range of chemical composition and aim analyses including residual elements if specific limits are specified; if the range of chemical composition depends on thickness and supply condition, the different ranges are to be specified, as appropriate
 - Maximum ferrite content for austenitic grades and ferrite-austenite ratio for duplex grades
 - Production statistics of the chemical composition and mechanical properties (R_{eH} , R_m , A% and KV).
- b) List of permitted cargoes and particular conditions for transportation if any.

- c) Steelmaking process
- Capacity of furnace(s)
 - Raw material used
 - Deoxidation, refining and alloying practice
 - Ladle treatment (desulphurisation, vacuum degassing installations...).
- d) Casting methods: ingot or continuous casting
- In the case of continuous casting, information relevant to type of casting machine, teeming practice, methods to prevent re-oxidation, inclusions and segregation control is to be provided as appropriate:
- Ingot or slab size and weight
 - Ingot or slab treatment: scarfing and discarding procedures.
- e) Reheating and rolling
- Type of furnace and treatment parameters (reheating temperature, time...)
 - Rolling: reduction ratio of slab/bloom/billet to finished product thickness, rolling and finishing temperatures
 - Descaling treatment during rolling
 - Capacity of the rolling stands.
- f) Heat treatment
- Type of furnaces, heat treatment parameters and their relevant records
 - Accuracy and calibration of temperature control devices.
- g) Surface finishing: pickling or other methods.
- h) Surface and internal conditions, specification or standard used; repair procedure for surface defects if any.
- i) Recommendations for working, welding and surface cleaning:
- Cold and hot working recommendations
 - Minimum and maximum heat input, recommended filler metals
 - Cleaning, pickling and passivating recommendations (initial and in-service).
- j) Where any part of the manufacturing process is assigned to other companies or other manufacturing plants, additional information required by the Society is to be included.
- k) For the approval of the semi-finished products such as slabs, blooms and billets, the above information a) to d) is to be given.

10.3 Selection of the test product

10.3.1 For each grade of steel and for each manufacturing process (e.g. steel making, casting, rolling and condition of supply), two products (one per cast) from two different casts representing the average and the maximum thickness (dimension) to be approved are in general to be selected for each kind of product. For grades 317L and 317LN, two products from each cast are to be selected.

Table 6 : Tests on rolled products for austenitic grades

Type of test	Position of the samples and direction of the test specimens (1)	Remarks
Tensile test	Top and bottom - transverse (2)	R_{eH} , R_m , A5(%), RA(%) are to be reported
Tensile test at elevated temperature: 50°C, 75°C and 100°C	Top and bottom - transverse (2)	R_m and $R_{p0.2}$ are to be reported
Impact tests	Top and bottom - longitudinal and transverse	Testing temperature (°C): 0°C and -196°C
Chemical composition	From top tensile specimen	Complete analysis including micro alloying elements and residual elements (C, Mn, Si, S, P, Cr, Ni, Mo, N, Cu, Sn, Sb, B, Ti, Nb, Va...)
Micro examination	Top and bottom	Surface and mid-thickness at magnification 100 and 500
Determination of ferrite delta content, Detection of detrimental phases (sigma)	Top and bottom	
Liquid penetrant test	Spot checks	Both surfaces and edges to be checked No cracks allowed
Ultrasonic test	All plates	According to procedure submitted
Conventional accelerated corrosion tests (3)	On each cast	ASTM A262 Pr. E (4) ASTM A 262 Pr. C (5)
Special corrosion test in phosphoric media (6)	On each cast	Test type "weight loss"
Bend test (for information)	Top - transverse	Bend angle 180° on 3t
<p>(1) For hot rolled strips see [1.6].</p> <p>(2) Longitudinal direction for sections and plates having width less than 600 mm.</p> <p>(3) These tests are strictly conventional and do not aim at providing guarantees on the effective resistance of the steel to the corrosion due to the chemicals carried, in the actual service conditions.</p> <p>(4) After sensitizing treatment 700°C during 30 minutes for stabilized and low carbon grades.</p> <p>(5) Not to be carried out on Mo alloyed grades.</p> <p>(6) To be agreed in case of particular cargoes.</p>		

10.4 Extent of the approval tests

10.4.1 The extent of the test program is specified in [10.5] and [10.6]; it may be modified on the basis of the preliminary information submitted by the manufacturer.

In particular a reduction of the indicated number of casts, steel plate thicknesses and grades to be tested or complete suppression of the approval tests may be accepted by the Society taking into account:

- Approval already granted by other Classification Societies and documentation of approval tests performed
- Grades of steel to be approved and availability of long term statistic results of chemical and mechanical properties.

On the other hand, an increase of the number of casts and thicknesses to be tested may be required in the case of newly developed types of steel or manufacturing processes. Where the number of tests differs from those shown in [10.5] and [10.6], the program is to be confirmed by the Society before the tests are carried out.

10.5 Tests on rolled products for austenitic grades (304L, 316L, 316LN, 317L, 317LN)

10.5.1 The tests to be carried out are indicated in Tab 6.

10.6 Tests for austenitic-ferritic grades

10.6.1 Tests on rolled products

The tests to be carried out are indicated in Tab 7.

10.6.2 Weldability tests

Weldability tests are required for plates and are to be carried out on samples of the thickest plate.

The following test assemblies are in general required:

- 1 butt weld test assembly welded with a heat input equal to the minimum heat input recommended by the steelmaker
- 1 butt weld test assembly welded with a heat input equal to the maximum heat input recommended by the steelmaker.

The butt weld test assemblies are to be prepared with the weld seam transverse to the plate rolling direction, so that impact specimens will result in the longitudinal direction.

The bevel preparation should be preferably 1/2V or K depending on the thickness.

The welding procedure should be as far as possible in accordance with the normal welding practice used at the yards for the type of steel in question.

Table 7 : Tests on rolled products for austenitic-ferritic grades

Type of test	Position of the samples and direction of the test specimens (1)	Remarks
Tensile test	Top and bottom - transverse (2)	R_{eH} , R_m , A5(%), RA(%) are to be reported
Tensile test at elevated temperature: 50°C, 75°C and 100°C	Top and bottom - transverse (2)	R_m and $R_{p0.2}$ are to be reported
Impact tests	Top and bottom - longitudinal and transverse	Testing temperature (°C): 0°C, -20°C, -40°C, -60°C
Chemical composition	From top tensile specimen	Complete analysis including micro alloying elements and residual elements (C, Mn, Si, S, P, Cr, Ni, Mo, N, Cu, Sn, Sb, B, Ti, Nb, Va...)
Micro examination	Top and bottom	Surface and mid-thickness at magnification 100 and 500
Determination of ferrite/austenite ratio, Detection of detrimental phases (sigma)	Top and bottom	
Liquid penetrant test	Spot checks	Both surfaces and edges to be checked No cracks allowed
Ultrasonic test	All plates	According to procedure submitted
Conventional accelerated corrosion tests (3)	On each cast	ASTM A 262 Pr. C
Special corrosion test in phosphoric media (4)	On each cast	Test type "weight loss"
Bend test (for information)	Top - transverse	Bend angle 180° on 3t
<p>(1) For hot rolled strips see [1.6].</p> <p>(2) Longitudinal direction for sections and plates having width less than 600 mm.</p> <p>(3) These tests are strictly conventional and do not aim at providing guarantees on the effective resistance of the steel to the corrosion due to the chemicals carried, in the actual service conditions</p> <p>(4) To be agreed in case of particular cargoes</p>		

The welding parameters including consumables brand name, designation and diameter, pre-heating temperatures, interpass temperatures, heat input, number of passes, etc. are to be reported.

From the test assemblies the following test specimens are to be taken:

- a) One cross weld tensile test.
- b) Two sets of 3 Charpy V-notch impact specimens transverse to the weld with the notch located at the fusion line and at a distance 1, 3, 5, 7 and minimum 20 mm from the fusion line. The fusion boundary is to be identified by etching the specimens with a suitable reagent. The test temperature is 0°C and -20°C. The minimum average impact energy shall exceed 27 J.
- c) Hardness tests HV 5 across the weldment. The indentations are to be made along a 1mm transverse line beneath the plate surface on both the face side and the root side of the weld as follows:
 - Weld metal, at each 2 mm
 - Fusion line
 - HAZ: at each 0,5 mm from fusion line into unaffected base material.
- d) Determination of ferrite content (aim at 30% - 60%) in base metal heat affected zone and for information in weld metal.

11 Round bars for anchor chain cables

11.1 Scope

11.1.1 This Article gives the approval test program for the manufacture of round bars made of steel grade Q1, Q2 or Q3 used for the manufacture of anchor chain cables.

11.2 Selection of the test product

11.2.1 For each grade of steel and for each manufacturing process (e.g. steel making, casting, rolling and condition of supply), two products (one per cast) from two different casts representing maximum diameter to be approved are in general to be selected for each kind of product.

The bars are to be heat treated in a way to simulate the heat treatment made during the manufacture of the anchor chain cable.

11.3 Extent of the approval tests

11.3.1 The extent of the test program is specified in [11.4]; it may be modified on the basis of the preliminary information submitted by the manufacturer.

In particular a reduction or complete suppression of the approval tests may be accepted by the Society taking into account:

- a) Approval already granted by other Classification Societies and documentation of approval tests performed
- b) Grades of steel to be approved and availability of long term statistic results of chemical and mechanical properties
- c) Approval of one yield strength level covers the approval of the yield strength level immediately below, provided the steelmaking process, deoxidation and fine grain practice, casting method and condition of supply are the same.

On the other hand, an increase of the number of casts and thicknesses to be tested may be required in the case of newly developed types of steel or manufacturing processes.

Where the number of tests differs from those shown in [11.4], the program is to be confirmed by the Society before the tests are carried out.

11.4 Tests on round bars

11.4.1 The tests to be carried out are indicated in Tab 8.

12 Clad steel plates

12.1 Scope

12.1.1 This Article gives the approval test program for the manufacture of clad steel plates for ships.

12.2 Manufacturing process specification

12.2.1 The following information is to be supplied by the manufacturer:

- a) Steel grade of base material and stainless steel grade of cladding material
- b) Thickness range and tolerances on clad plate
- c) Details about manufacturing process, rolling or explosive bonding and associated inspection points and procedures.

Table 8 : Tests on round bars

Type of test		Position of the samples and direction of the test specimens	Remarks			
Tensile test		Longitudinal with axis at 1/3radius below the surface	R _{eH} , R _m , A5(%), RA(%) are to be reported			
Impact tests	Steel grade Q1	Longitudinal with axis at 1/3radius below the surface	Testing temperature (°C):	+20	0	
	Steel grade Q2			+20	0	-20
	Steel grade Q3			+20	0	-20
Chemical composition		From top tensile specimen	Complete analysis including micro alloying elements			
Sulphur prints		Longitudinal mid-section				
Micro examination		Longitudinal section at 1/3 radius below the surface	Magnification 100 and 500			
Macro examination		Longitudinal mid-section				

Table 9 : Tests on clad plate

Type of test	Position of the samples and direction of the test specimens	Remarks
Chemical composition of base material and cladding material	From test specimen	Complete analysis including micro alloying elements
Tensile test	Full clad plate	As per NR216 Materials and Welding, Ch 2, Sec 1 for clad plates
Impact tests on base material	Longitudinal and transverse	Testing temperature (°C) at T°C (test temperature specified for base material) and at (T - 20)°C
Bend tests	Full clad plate, one from each end of the clad plate	As per NR216 Materials and Welding, Ch 2, Sec 1 for clad plates
Shear test		As per NR216 Materials and Welding, Ch 2, Sec 1 for clad plates
Micro examination	Showing bonded area and surfaces of base material and cladding material	Magnification 100
Ultrasonic testing		As per NR216 Materials and Welding, Ch 2, Sec 1 for clad plates

12.3 Selection of the test product

12.3.1 Two clad plates are to be selected from current production representing the average and the maximum thickness to be approved.

12.4 Extent of the approval tests

12.4.1 The extent of the test program is specified in [12.5]; it may be modified on the basis of the preliminary information submitted by the manufacturer.

Where the number of tests differs from those shown in [12.5], the program is to be confirmed by the Society before the tests are carried out.

12.5 Tests on clad plate

12.5.1 The tests to be carried out are indicated in Tab 9.

13 Plates with specified through thickness properties

13.1 Scope

13.1.1 This Article gives the approval test program for the manufacture of plates with specified through thickness properties.

13.2 Manufacturing process specification

13.2.1 In addition to the information mentioned in [1.2], the following information is to be supplied:

- Maximum thickness and steel grades with delivery conditions for which approval is requested
- Details about process modifications to obtain the properties (inclusion shape control, low sulphur...)
- Ultrasonic examination procedures and acceptance criteria.

13.3 Selection of the test product

13.3.1 One plate representative of maximum thickness to be approved is to be selected.

13.4 Extent of the approval tests

13.4.1 The extent of the test program is specified in [13.5]; it may be modified on the basis of the preliminary information submitted by the manufacturer.

Where the number of tests differs from those shown in [13.5], the program is to be confirmed by the Society before the tests are carried out.

13.5 Tests on plates

13.5.1 The tests to be carried out are indicated in Tab 10.

Table 10 : Tests on plates

Type of test	Position of the samples and direction of the test specimens	Remarks
Chemical composition	From test specimen	Complete analysis including micro alloying elements
Through thickness tensile test	<ul style="list-style-type: none"> • Top and axis of the plate, 3 specimens • Top and mid-way between axis and edge of the plate, 3 specimens • Bottom and axis of the plate, 3 specimens • Bottom and mid-way between axis and edge of the plate, 3 specimens 	
Ultrasonic testing		As per NR216 Materials and Welding, Ch 2, Sec 1, [11.10]

SECTION 3

SEAMLESS PIPES AND FITTINGS

1 Seamless pipes and fittings

1.1 Scope

1.1.1 This Section gives the scheme for the approval of the manufacturing process of seamless pipes and fittings made of low alloy and alloy steel grades intended for high temperature use.

A similar scheme may be used for approval of manufacturing process of seamless pipes and fittings for other applications upon special consideration by the Society.

1.2 Approval Range

1.2.1 The range of product to be approved is to be submitted together with test program at the request for approval.

Range of product is to be defined for the manufacturing process to be approved, including the following information:

- For each type of steel, the grade of material with reference to Rules, and/or standard and material specifications
- Range of dimensions (wall thickness, diameter, length)
- Heat treatment and delivery conditions.

The approval will be limited to the type of steel, and, up to the maximum dimensions of seamless pipes and fittings used for approval test program unless otherwise agreed by the Society.

1.3 Manufacturing process specification

1.3.1 The following manufacturing process information and relevant documentation are to be submitted together with the request for approval and in addition to general information as detailed in Sec 1, [1.3].

- a) Manufacture of the steel and semi-finished products
 - Steelmaking process and capacity of furnace(s) or converter(s), raw material used, deoxidation and alloying practice, vacuum degassing, casting method(s)
 - Semi-finished products: weight and size range
 - List of semi-finished products suppliers.
- b) Description of the manufacturing process
 - Description of forming operations
 - List of manufacturing equipment and facilities.

- c) Heat treatment
 - Type of furnaces and capacity.
 - Heat treatment parameters (loading temperature, heating rate, holding temperature with tolerances and holding times, cooling details) and their relevant records.
 - Subcontracting the heat treatment, etc.
- d) Quality controls from raw materials to finished products
 - Laboratory facilities and equipment for inspection and testing
 - Quality control documentation, description including a process flow chart.

e) Alternative to the Hydraulic test

If a non destructive test of the whole pipe is proposed by the manufacturer as an alternative to the hydraulic pressure test, the relevant procedure is to be supplied and is to contain details on the following:

- Method, type of equipment and capacity (pipe wall thickness and outside diameter range)
- Calibration criteria, dimension and position of artificial defects
- Frequency of calibration
- Length of untested ends, if applicable
- Sensitivity to detect internal, external defects
- Acceptance, rejection criteria
- Operators qualification according to international standard.

1.4 Documents to be submitted for changing the approval conditions

1.4.1 The manufacturer has to submit to the Society the documents required in [1.3] together with the request of changing the approval conditions, in the case of change of the approval conditions (e.g. dimension range, steel grades, etc.).

However, where the documents are duplicated by the ones at the previous approval for the same type of product, part or all of the documents may be omitted except the approval test program.

1.5 Approval survey

1.5.1 The approval tests are to be witnessed by the Surveyor at the manufacturer's plant and the execution of the plant inspection in operation may be required by the Surveyor during the visit for the approval.

If the testing facilities are not available at the works, the tests are to be carried out at laboratories accepted by the Society.

1.6 Approval test program

1.6.1 Selection of the test product

For each grade of steel and for each condition of supply, two test products originating from different heats and representing the average and the maximum dimensions to be approved are in general to be selected.

1.6.2 Extent of the approval tests

The extent of the test program is specified in [1.7]; it may be modified on the basis of the preliminary information submitted by the manufacturer.

In particular a reduction of the indicated number of products and grades to be tested or complete suppression of the approval tests may be accepted by the Society taking into account:

- Approval already granted by other Classification Societies and documentation of approval tests performed.
- Grades of steel to be approved and availability of long term statistic results of chemical and mechanical properties.
- Approval for any grade of steel also covers approval for any lower grade in the same strength level, provided that the method of manufacture and condition of supply are similar.
- Approval for a strength level may cover approval for lower strength levels provided that the type of steel and the conditions of supply are the same.

Where the number of tests differs from those shown in [1.7], the program is to be confirmed by the Society before the tests are carried out.

1.6.3 Sampling and position of test specimens

The test samples are to be taken in accordance with NR216 Materials and Welding, Ch 2, Sec 2.

The test specimens and testing procedures are to be, as a rule, in accordance with NR216 Materials and Welding, Ch 1, Sec 2.

1.7 Approval tests

1.7.1 The tests to be carried out are indicated in Tab 1.

1.7.2 Results and records

All the results, which are to comply with the requirements of NR 216 Materials and Welding and approved material specification, are evaluated for the approval; depending on the results, particular limitations or testing conditions, as deemed appropriate, may be specified in the approval document.

All the information required under [1.3] is to be collected by the manufacturer and put in the technical documentation which will include all the results of the tests and operation records relevant to steelmaking, forming operations, and, heat treatment of each tested product.

When steel is cast in a mill other than where the seamless pipes and fittings are manufactured, the steelmaker's certificate stating the manufacturing process, the grade of steel, the cast number and the relevant ladle analysis is to be provided for each tested product.

Table 1 : Tests on seamless pipes

Type of test	Position of the samples and direction of the test specimens	Remarks
For each product, all the relevant tests required in NR216 Materials and Welding, Ch 2, Sec 2 are to be performed in addition to the following tests (1)		
Chemical composition	From product sample	Complete analysis
Microexamination		Magnification 100
Segregation examination	Cross-sectional area	Sulphur print; other tests than Sulphur prints for segregation examination may be agreed with the Society
Dimensional examination		
(1) When non-destructive examination is required by NR 216, NDT report is to be provided and shall include: reference to a testing standard and procedure, extent of testing, rejection/acceptance criteria and statement for results of examination, identification and signature of qualified NDT operator		

SECTION 4 WELDED PIPES AND FITTINGS

1 Welded pipes and fittings

1.1 Scope

1.1.1 This Section gives the scheme for the approval of the manufacturing process of welded pipes and fittings intended for structural applications, boilers, pressure vessels, and systems operating at ambient, high or low temperature.

1.2 Approval range

1.2.1 The range of product to be approved is to be submitted together with test program and the request for approval.

Range of product is to be defined for the manufacturing process to be approved, including the following information:

- For each type of steel, the grade of material with reference to Rules, and/or standard and material specifications
- Range of dimensions (wall thickness, diameter, length)
- Welding process
- Heat treatment and delivery conditions.

The approval will be limited to the type of steel, and, up to the maximum dimensions of welded pipes and fittings used for approval test program unless otherwise agreed by the Society.

1.3 Manufacturing process specification

1.3.1 The following manufacturing process information and relevant documentation are to be submitted together with the request for approval and in addition to general information as detailed in Sec 1, [1.3].

- a) Manufacture of the steel and semi-finished products
 - Steelmaking process and capacity of furnace(s) or converter(s), raw material used, deoxidation and alloying practice, vacuum degassing, casting method(s)
 - Semi-finished products: weight and size range
 - List of semi-finished products suppliers.
- b) Description of the manufacturing process
 - Forming operations
 - Weld joint type, welding procedure specification and supporting welding procedure approval report, welding equipment.

c) Heat treatment

- Type of furnaces and capacity
- Heat treatment parameters (loading temperature, heating rate, holding temperature with tolerances and holding times, cooling details) and their relevant records
- Subcontracting the heat treatment, etc.

d) Quality controls from raw materials to finished products

- Laboratory facilities and equipment for inspection and testing
- Quality control documentation, description including a process flow chart
- Procedures for non destructive examination of the weld joint which is to contain details as described in e) hereafter.

e) Alternative to the Hydraulic test

If a non destructive test of the whole pipe is proposed by the manufacturer as an alternative to the hydraulic pressure test, the relevant procedure is to be supplied and is to contain details on the following

- Method, type of equipment and capacity (pipe wall thickness and outside diameter range)
- Calibration criteria, dimension and position of artificial defects
- Frequency of calibration
- Length of untested ends, if applicable
- Sensitivity to detect internal, external defects
- Acceptance, rejection criteria
- Operators qualification according to international standard.

1.4 Documents to be submitted for changing the approval conditions

1.4.1 The manufacturer has to submit to the Society the documents required in [1.3] together with the request of changing the approval conditions, in the case of change of the approval conditions (e.g. dimension range, steel grades, etc.).

However, where the documents are duplicated by the ones at the previous approval for the same type of product, part or all of the documents may be omitted except the approval test program.

1.5 Approval survey

1.5.1 The approval tests are to be witnessed by the Surveyor at the manufacturer's plant and the execution of the plant inspection in operation may be required by the Surveyor during the visit for the approval.

If the testing facilities are not available at the works, the tests are to be carried out at laboratories accepted by the Society.

1.6 Approval test program

1.6.1 Selection of the test product

For each grade of steel, each manufacturing process and each condition of supply, two test products originating from different heats and representing the average and the maximum dimensions to be approved are in general to be selected.

1.6.2 Extent of the approval tests

The extent of the test program is specified in [1.7]; it may be modified on the basis of the preliminary information submitted by the manufacturer.

In particular a reduction of the indicated number of products and grades to be tested or complete suppression of the approval tests may be accepted by the Society taking into account:

- a) Approval already granted by other Classification Societies and documentation of approval tests performed.
- b) Grades of steel to be approved and availability of long term statistic results of chemical and mechanical properties.
- c) Approval for any grade of steel also covers approval for any lower grade in the same strength level, provided that the method of manufacture and condition of supply are similar.

- d) Approval for a strength level may cover approval for lower strength levels provided that the type of steel and the conditions of supply are the same.

Where the number of tests differs from those shown in [1.7], the program is to be confirmed by the Society before the tests are carried out.

1.6.3 Sampling and position of test specimens

The test samples are to be taken in accordance with NR216 Materials and Welding, Ch 2, Sec 2.

The test specimens and testing procedures are to be, as a rule, in accordance with NR216 Materials and Welding, Ch 1, Sec 2.

1.7 Approval tests

1.7.1 The tests to be carried out are indicated in Tab 1.

1.7.2 Results and records

All the results, which are to comply with the requirements of NR 216 Materials and Welding and approved material specification, are evaluated for the approval; depending on the results, particular limitations or testing conditions, as deemed appropriate, may be specified in the approval document.

All the information required under [1.3] is to be collected by the manufacturer and put in the technical documentation which will include all the results of the tests and operation records relevant to steelmaking, casting, forming, welding operations, and, heat treatment of each tested product.

When steel is cast in a mill other than where the welded pipes are manufactured, the steelmaker's certificate stating the manufacturing process, the grade of steel, the cast number and the relevant ladle analysis is to be provided for each tested product.

Table 1 : Tests on welded pipes

Type of test	Position of the samples and direction of the test specimens	Remarks
For each product, all the relevant tests required in NR216 Materials and Welding, Ch 2, Sec 2 are to be performed in addition to the following tests (1):		
Chemical composition	From product sample	Complete analysis, material for product analysis should be taken from tensile specimen
Microstructure examination and hardness	Including weld metal, fusion line and heat affected zone	Magnification 100; Hardness HV5 Vickers on weld metal, heat affected zone and base metal to be recorded
Macro examination	Transverse to the weld	
Segregation examination	Top and bottom	Sulphur print, other tests than sulphur print for segregation examination may be agreed with the Society
Checking of ferrite content	Base material, heat affected zone and weld metal	Applicable only to duplex stainless steel grades
(1) When non-destructive examination is required by NR 216, NDT report is to be provided and shall include: reference to a testing standard and procedure, extent of testing, rejection/acceptance criteria and statement for results of examination, identification and signature of qualified NDT operator.		

SECTION 5 STEEL FORGINGS

1 Steel forgings

1.1 Scope

1.1.1 This Section gives the scheme for the approval of the manufacturing process of steel forgings intended for hull, structural applications, offshore construction, machinery, boilers, pressure vessels and piping systems.

A similar scheme may be used for approval of manufacturing process of others forgings type upon special consideration by the Society.

1.2 Approval range

1.2.1 The range of product to be approved is to be submitted together with test program and the request for approval.

Range of product is to be defined for the manufacturing process to be approved, including the following information:

- For each type of steel, the grade of material with reference to Rules, and/or standard and material specifications
- Range of dimensions (e.g. diameter, length etc.), and, net weight
- Heat treatment and delivery conditions.

The approval will be limited to the type of steel, and, up to the maximum net weight of steel forgings used for approval test program unless otherwise agreed by the Society.

1.3 Manufacturing process specification

1.3.1 The following information and relevant documentation are to be submitted together with the request for approval and in addition to general information as detailed in Sec 1, [1.3]:

- a) Manufacture of the steel and semi-finished products
 - Production method of original steel: steelmaking process and capacity of furnace(s) or converter(s), raw material used, deoxidation and alloying practice, vacuum degassing, casting method(s)
 - Semi-finished products: weight and size range
 - List of semi-finished product suppliers, if applicable.
- b) Forging process
 - Description of forging facilities: forging equipment type and capacity (e.g. presses, hammers, etc.), heat treating furnace(s) type and capacity used for reheating operations.
 - Description of forging process: Typical range of hot-forming temperatures and hold times, forging steps with sketches showing forming of forging from the ingot stage and relevant reduction ratio. Unless otherwise approved, the minimum total reduction ratio is to be in accordance with NR216 Materials and Welding, Ch 2, Sec 3.

erwise approved, the minimum total reduction ratio is to be in accordance with NR216 Materials and Welding, Ch 2, Sec 3.

- Description of special processes adopted for grain flow forged products and for forgings with weld joints.
- c) Heat treatment
 - Description of heat treatment facilities: furnace(s) type and capacity, cooling facilities
 - Description of heat treatment cycle(s): loading temperature, heating rate, holding temperature with tolerances and holding times, cooling details (e.g. medium type, cooling rate, transfer time(s), etc.)
 - Alternative procedure to conventional heat treatment, as controlled cooling from finishing forging temperature
 - Subcontracting the heat treatment, etc.
- d) Quality control and testing
 - Laboratory facilities and equipment for inspection and testing
 - Quality control documentation; description including a process flow chart with details about inspection points and a list of applicable instructions
 - Non-destructive examination procedures, together with rejection/acceptance criteria
 - List of personnel in charge of the non-destructive testing and their qualification.

1.4 Documents to be submitted for changing the approval conditions

1.4.1 The manufacturer has to submit to the Society the documents required in [1.3] together with the request of changing the approval conditions, in the case of change of the approval conditions (e.g. dimension and net weight range, type of steel, manufacturing process etc.).

However, where the documents are duplicated by the ones at the previous approval for the same type of product, part or all of the documents may be omitted except the approval test program.

1.5 Approval survey

1.5.1 The approval tests are to be witnessed by the Surveyor at the manufacturer's plant and the execution of the plant inspection in operation may be required by the Surveyor during the visit for the approval.

If the testing facilities are not available at the works, the tests are to be carried out at laboratories accepted by the Society.

1.6 Approval test program

1.6.1 Selection of test product

The selected test products shall be representative of the type and weight range for which approval is requested.

The approval may be requested for the following type of steel:

- Carbon steels
- Carbon-manganese steels
- Low-alloy steels
- Alloy steels
- Stainless steels.

When the approval is applied for one type of steel, two forgings, from two different casts, representative of the range of forgings to be approved are to be tested. When the approval is applied for carbon, carbon-manganese, low-alloy and alloy steels, it may be reduced to one cast only per each type of steel.

1.6.2 Extent of the approval tests

The extent of the test program is specified in [1.7]; it may be modified on the basis of the preliminary information submitted by the manufacturer.

In particular a reduction of the indicated number of products and grades to be tested or complete suppression of the approval tests may be accepted by the Society taking into account:

- a) Approval already granted by other Classification Societies and documentation of approval tests performed.
- b) Grades of steel to be approved and availability of long term statistic results of chemical and mechanical properties.

Where the number of tests differs from those shown in [1.7], the program is to be confirmed by the Society before the tests are carried out.

1.6.3 Sampling and position of test specimens

The test samples are to be taken in accordance with NR216 Materials and Welding, Ch 2, Sec 3 for the type of steel forging involved.

The test specimens and testing procedures are to be, as a rule, in accordance with NR216 Materials and Welding, Ch 1, Sec 2.

1.7 Approval tests

1.7.1 The tests to be carried out are indicated in Tab 1.

1.7.2 Results and records

All the results, which are to comply with the requirements of NR 216 Materials and Welding and approved material specification, are evaluated for the approval; depending on the results, particular limitations or testing conditions, as deemed appropriate, may be specified in the approval document.

All the information required under [1.3] is to be collected by the manufacturer and put in the technical documentation which will include all the results of the tests and operation records relevant to steelmaking, casting, hot forgings operations with total reduction ratio, and, heat treatment of each tested product.

When steel is cast in a mill other than where the steel forgings are manufactured, the steelmaker's certificate stating the manufacturing process, the grade of steel, the cast number and the relevant ladle analysis is to be provided for each tested product.

Table 1 : Tests on steel forgings

Type of test (1)	Position of the samples and direction of the test specimens	Remarks
For each product, all the relevant tests required in NR216 Materials and Welding, Ch 2, Sec 3 are to be performed in addition to the following tests (2):		
Chemical composition	From ladle and product sample	Complete analysis, material for product analysis should be taken from tensile specimen
Microstructure examination		At magnification 100 and 500
Segregation examination	Top and bottom	Sulphur print, other tests than sulphur print for segregation examination may be agreed with the Society
Macro examination for grain flow forged products	Full cross-section	Macro etching of cross section surface according to recognised standard such as ASTM E381
(1) For special grades, case by case approval test program is to be considered.		
(2) When non-destructive examination is required by NR 216, NDT report is to be provided and shall include: reference to a testing standard and procedure, extent of testing, rejection/acceptance criteria and statement for results of examination, identification and signature of qualified NDT operator.		

SECTION 6 STEEL CASTINGS

1 Steel castings

1.1 Scope

1.1.1 This Section gives the scheme for the approval of the manufacturing process of steel castings intended for hull, structural applications, offshore construction, machinery, propellers, boilers, pressure vessels and piping systems.

A similar scheme may be used for approval of manufacturing process of others castings type upon special consideration by the Society.

1.2 Approval range

1.2.1 The range of product to be approved is to be submitted together with test program and the request for approval.

Range of product is to be defined for the manufacturing process to be approved, including the following information:

- For each type of steel, the grade of material with reference to Rules, and/or standard and material specifications
- Range of dimensions, and, net weight
- Heat treatment and delivery conditions.

The approval will be limited to the type of steel, and, up to the maximum net weight of steel castings used for approval test program unless otherwise agreed by the Society.

1.3 Manufacturing process specification

1.3.1 The following information and relevant documentation are to be submitted together with the request for approval and in addition to general information as detailed in Sec 1, [1.3]:

- a) Manufacture of the steel and casting process
 - Production method of original steel: steelmaking, and capacity of furnace(s) or converter(s), raw material used, deoxidation and alloying practice, vacuum degassing, casting, as applicable.
 - Description of casting facilities: type and capacity of melting furnace(s), casting processes (e.g. investment, centrifugal, sand castings, etc.), moulding method, type of sand, binding agent and method of casting.
- b) Heat treatment
 - Description of heat treatment facilities: furnace(s) type, cooling facilities.
 - Description of heat treatment cycle(s): loading temperature, heating rate, holding temperature with tolerances and holding times, cooling details (e.g. medium type, cooling rate, transfer time(s), etc.).
 - Subcontracting the heat treatment, etc.

c) Quality control and testing

- Laboratory facilities and equipment for inspection and testing.
- Quality control documentation; description including a process flow chart with details about inspection points and a list of applicable instructions.
- Non-destructive examination procedures, together with rejection/acceptance criteria.
- List of personnel in charge of the non-destructive testing and their qualification.

1.4 Documents to be submitted for changing the approval conditions

1.4.1 The manufacturer has to submit to the Society the documents required in [1.3] together with the request of changing the approval conditions, in the case of change of the approval conditions (e.g. dimension and net weight range, type of steel, manufacturing process etc.).

However, where the documents are duplicated by the ones at the previous approval for the same type of product, part or all of the documents may be omitted except the approval test program.

1.5 Approval survey

1.5.1 The approval tests are to be witnessed by the Surveyor at the manufacturer's plant and the execution of the plant inspection in operation may be required by the Surveyor during the visit for the approval.

If the testing facilities are not available at the works, the tests are to be carried out at laboratories accepted by the Society.

1.6 Approval test program

1.6.1 Selection of test product

The selected test products shall be representative of the type and weight range for which approval is requested.

The approval may be requested for the following type of steel:

- Carbon steels
- Carbon-manganese steels
- Low-alloy steels
- Alloy steels
- Stainless steels.

When the approval is applied for one type of steel, two castings, from two different casts, representative of the range of castings to be approved are to be tested. When the approval is applied for carbon, carbon-manganese, low-alloy and alloy steels, it may be reduced to one cast only per each type of steel.

1.6.2 Extent of the approval tests

The extent of the test program is specified in [1.7]; it may be modified on the basis of the preliminary information submitted by the manufacturer.

In particular a reduction of the indicated number of products and grades to be tested or complete suppression of the approval tests may be accepted by the Society taking into account:

- a) Approval already granted by other Classification Societies and documentation of approval tests performed.
- b) Grades of steel to be approved and availability of long term statistic results of chemical and mechanical properties.

Where the number of tests differs from those shown in [1.7], the program is to be confirmed by the Society before the tests are carried out.

1.6.3 Sampling and position of test specimens

The test samples and the test specimens are to be taken in accordance with NR216 Materials and Welding, Ch 2, Sec 4 for the type of steel casting involved.

The test specimens and testing procedures are to be, as a rule, in accordance with NR216 Materials and Welding, Ch 1, Sec 2.

1.7 Approval tests

1.7.1 The tests to be carried out are indicated in Tab 1.

1.7.2 Results and records

All the results, which are to comply with the requirements of NR216 Materials and Welding and approved material specification, are evaluated for the approval; depending on the results, particular limitations or testing conditions, as deemed appropriate, may be specified in the approval document.

All the information required under [1.3] is to be collected by the manufacturer and put in the technical documentation which will include all the results of the tests and operation records relevant to steelmaking, casting, and, heat treatment of each tested product.

Table 1 : Tests on steel castings

Type of test (1)	Position of the samples and direction of the test specimens	Remarks
For each product, all the relevant tests required in NR216 Materials and Welding, Ch 2, Sec 4 are to be performed in addition to the following tests (2):		
Chemical composition	From ladle and product sample	Complete analysis, material for product analysis should be taken from tensile specimen
Microstructure examination		At magnification 100 and 500
<p>(1) For special grades, case by case approval test program is to be considered.</p> <p>(2) When non-destructive examination is required by NR 216, NDT report is to be provided and shall include: reference to a testing standard and procedure, extent of testing, rejection/acceptance criteria and statement for results of examination, identification and signature of qualified NDT operator.</p>		

SECTION 7

WROUGHT ALUMINIUM ALLOY PRODUCTS

1 Wrought aluminium alloy products

1.1 Scope

1.1.1 This Section gives the scheme for the approval of the manufacturing process of wrought aluminium alloy products for ships.

1.2 Manufacturing process specification

1.2.1 The following information is to be supplied by the manufacturer:

- a) Type of products (rolled, extruded), grades of aluminium alloy, conditions of supply, range of dimension and aim material properties as follows:
 - Range of chemical composition and aim analyses including maximum impurities content; if the range of chemical composition depends on thickness and supply condition, the different ranges are to be specified, as appropriate
 - Production statistics of the chemical composition and mechanical properties (R_{eH} , R_m , A%).
- b) For alloys not already covered by international standards including marine applications, the registration status for marine use to The Aluminium Association is to be supplied to the Society for information; In that case the manufacturer is to supply also information about the design, development and qualification stages of such alloy (modification of existing alloy, new alloy...)
- c) Description of alloy making and semi-finished products making process
- d) Use of semi-finished products manufactured by other plants or companies
- e) Description of rolling or extruding process
- f) Heat treatment:
 - type of furnaces, heat treatment parameters and their relevant records
 - accuracy and calibration of temperature control devices.
- g) Information about welding; recommended filler metals, as welded properties,...
- h) Recommendations for working
- i) Where any part of the manufacturing process is assigned to other companies or other manufacturing plants, additional information required by the Society is to be included.

1.3 Documents to be submitted for changing the approval conditions

1.3.1 The manufacturer has to submit to the Society the documents required in [1.2] together with the request of changing the approval conditions, in the case of the following a) through e):

- a) change of the manufacturing process (alloy making, casting, rolling and heat treatment)
- b) change of the range of approval
- c) change of the chemical composition, added element, etc
- d) subcontracting the rolling, heat treatment, etc
- e) use of semi-finished products manufactured by other companies which are not approved.

However, where the documents are duplicated by the ones at the previous approval for the same type of product, part or all of the documents may be omitted except the approval test program.

1.4 Approval survey

1.4.1 The approval tests are to be witnessed by the Surveyor at the manufacturer's plant and the execution of the plant inspection in operation may be required by the Surveyor during the visit for the approval.

If the testing facilities are not available at the works, the tests are to be carried out at laboratories accepted by the Society.

1.5 Position of the test samples

1.5.1 The position of the samples are to be in accordance with NR216 Materials and Welding, Ch 3, Sec 2.

1.6 Test specimens and testing procedure

1.6.1 The test specimens and testing procedures are to be, as a rule, in accordance with NR216 Materials and Welding, Ch 1, Sec 2.

The test results are to be in accordance, where applicable, with the requirements specified for the different alloys in NR216 Materials and Welding, Ch 3, Sec 2.

1.7 Selection of the test product

1.7.1 For each grade of aluminium alloy, condition of supply and for each manufacturing process (rolling, extruding and condition of supply), two test products originating from two different heats and representing the average and the maximum thickness (dimension) to be approved are in general to be selected for each kind of product.

1.8 Extent of the approval tests

1.8.1 The extent of the test program is specified in [1.9]; it may be modified on the basis of the preliminary information submitted by the manufacturer.

In particular a reduction of the indicated number of heats, dimensions and grades to be tested may be accepted by the Society taking into account:

- Approval already granted by other Classification Societies and documentation of approval tests performed.
- Grades of aluminium alloys to be approved and availability of long term statistic results of chemical and mechanical properties.

When long term statistic results are available for following alloys, approval tests may be reduced to routine tests as per NR216 Materials and Welding, Ch 3, Sec 2:

- Series 5000 alloys:
5083 - 5086 - 5052 - 5154A - 5454 - 5754 in temper state 0 - H111 - H112 - H116 - H321 - H32 - H22 - H34 - H24 - H36 - H26
- Series 6000 alloys:
6005A - 6106 - 6061 - 6082 - 6060 in temper state T4 - T5 - T6.

On the other hand, an increase of the number of heats and thicknesses to be tested may be required in the case of newly developed types of aluminium alloys or manufacturing processes.

Where the number of tests differs from those shown in [1.9], the program is to be confirmed by the Society before the tests are carried out.

1.9 Tests on base material

1.9.1 The tests to be carried out are indicated in Tab 1.

1.10 Weldability tests

1.10.1 General

Weldability tests are required for plates and are to be carried out on samples of plate (average and maximum thickness) for alloys newly developed or newly manufactured.

1.10.2 Preparation and welding of the test assemblies

One butt weld is to be prepared for each thickness tested.

The welding procedure should be as far as possible in accordance with the normal welding practice used at the yards for the type of aluminium alloy in question.

The welding parameters including consumables designation and diameter, heat input, number of passes, etc. are to be reported.

1.10.3 Type of tests

The relevant tests required in NR216 Materials and Welding, Ch 5, Sec 4, [6] are to be performed with the following tests in addition:

- Corrosion tests on as welded samples and welded samples artificially aged at 100°C during 7 days: ASTM G66 (ASSET test) and ASTM G67 (NAMLT test)
These tests are to be repeated with the surface of the samples slightly machined (about 10% of original thickness material removed)
- Stress corrosion tests in marine atmosphere such as bending tests with a yield stress on the tension side up to 90% of heat affected zone yield strength performed on as welded samples and welded samples artificially aged at 100°C during 7 days
These tests are to be repeated with the surface of the samples slightly machined (about 10% of original thickness material removed).

1.10.4 Other tests

Additional tests such as fatigue tests may be required in the case of newly developed type of aluminium alloys outside the scope of the NR216 Materials and Welding, or when deemed necessary by the Society.

Table 1 : Tests on base material

Type of test	Position of the samples and direction of the test specimens	Remarks
For each product, all the relevant tests required in NR216 Materials and Welding, Ch 3, Sec 2 are to be performed in addition to the following tests:		
Chemical composition	Product sample	Added elements Residual elements such as hydrogen (H), sodium (Na), tin (Sn), lead (Pb) and bismuth (Bi)
Tensile test	Top and bottom	R_{eH} , R_m , A5(%) are to be reported
Bend tests for rolled products	Top and bottom	180° bending, mandrel diameter agreed on case by case basis
Macro examination for extruded products	Cross-section	To check coarse grain size (ASTM E 112-88 growth index O) and extent of peripheric coarse grain areas (depth is not to exceed one third of product thickness)
Corrosion tests on base material (1)	Each product	ASTM G66 (ASSET test) and ASTM G67 (NAMLT test)
Corrosion tests on base material in artificially aged condition (1)	Each product	Artificially aged at 100°C during seven days ASTM G66 (ASSET test) and ASTM G67 (NAMLT test)
(1) For series 5000 alloys newly developed or newly manufactured.		

1.10.5 Results and records

All the results, which are to comply with the requirements of NR 216 Materials and Welding and approved material specification, are evaluated for the approval; depending on the results, particular limitations or testing conditions, as deemed appropriate, may be specified in the approval document.

All the information required under [1.2] is to be collected by the manufacturer and put in the technical documenta-

tion which will include all the results of the tests and operation records relevant to alloy making, casting, and, heat treatment of each tested product.

When the aluminium alloys are cast in a work other than where they are manufactured into finished products, the work's certificate stating the manufacturing process, the grade of aluminium alloy, the cast number and the relevant ladle analysis is to be provided for each tested product.

SECTION 8

EXPLOSION BONDED ALUMINIUM/STEEL TRANSITION JOINTS

1 Explosion bonded aluminium/steel transition joints

1.1 Scope

1.1.1 This Section gives the scheme for the approval of the manufacturing process of explosion bonded aluminium/steel transition joints for ships.

1.2 Manufacturing process specification

1.2.1 The following information is to be supplied by the manufacturer:

- a) Manufacturer's specification which is to contain following information:
 - Aluminium grades and steel grades used for the manufacture of the joints
 - Dimensions of the joints and thickness of the various layers
 - Guaranteed mechanical properties of the joints.
- b) Description of the manufacturing process including inspection points
- c) Non destructive tests procedures
- d) Recommendations for fitting, welding, cutting...

Where any part of the manufacturing process is assigned to other companies or other manufacturing plants, additional information required by the Society is to be included.

1.3 Documents to be submitted for changing the approval conditions

1.3.1 The manufacturer has to submit to the Society the documents required in [1.2] together with the request of changing the approval conditions, in case of the following:

- a) Change of the manufacturing process
- b) Change of the range of approval (thickness, material grades...).

However, where the documents are duplicated by the ones at the previous approval for the same type of product, part or all of the documents may be omitted except the approval test program.

1.4 Approval survey

1.4.1 The approval tests are to be witnessed by the Surveyor at the manufacturer's plant and the execution of the plant inspection in operation may be required by the Surveyor during the visit for the approval.

If the testing facilities are not available at the works, the tests are to be carried out at laboratories accepted by the Society.

1.5 Selection of the test product

1.5.1 For each type of joint to be approved, enough material is to be selected from current production to perform the approval tests.

1.6 Extent of the approval tests

1.6.1 The extent of the test program is specified in [1.7]; it may be modified on the basis of the preliminary information submitted by the manufacturer. In particular a reduction of the approval test program may be accepted by the Society taking into account:

- a) Approval already granted by other Classification Societies and documentation of approval tests performed
- b) Type of joints to be approved and availability of statistic results of mechanical properties.

On the other hand, an increase of the number of tests may be required in the case of newly developed type of joints.

Where the number of tests differs from those shown in [1.7], the program is to be confirmed by the Society before the tests are carried out.

1.7 Approval tests

1.7.1 The tests to be carried out are indicated in Tab 1.

1.8 Other tests

1.8.1 Additional tests such as corrosion tests may be required in the case of newly developed type of joints, or when deemed necessary by the Society.

Table 1 : Approval tests

Type of test	Position of the samples and direction of the test specimens	Remarks
For each product, all the relevant tests required in NR216 Materials and Welding, Ch 3, Sec 2 are to be performed in addition to the following tests:		
Through thickness tensile test	One sample	After heating to 320°C during 15 minutes
Bend test	Two samples	180° bending, mandrel diameter agreed on a case by case basis As bonded and after heating to 320°C during 15 minutes
Through thickness tensile tests on welded assembly		To be agreed on a case by case basis
Axial fatigue tension to compression tests		To be agreed on a case by case basis

SECTION 9

ANCHOR CHAIN CABLES AND ACCESSORIES FOR SHIPS

1 Anchor chain cables and accessories for ships

1.1 Scope

1.1.1 This Section gives the scheme for the approval of the manufacturing process of flash butt-welded or cast anchor chain cables for ships and associated cast or forged accessories (end link, enlarged link, anchor shackle, joining shackle, Kenter shackle and swivel).

The approval scheme for other manufacturing process is subjected to case by case consideration.

1.2 Manufacturing process specification

1.2.1 Flash butt-welded chain cables

The following information is to be supplied by the manufacturer:

- a) Steel grade specification for round bars and name and address of suppliers
- b) Size range to be approved and drawing of common chain link (including stud details for studlink chains)
- c) Description of the manufacturing process with details about:
 - welding machines
 - heat treatment furnaces, type, equipment for temperature monitoring and its calibration.
- d) Description of quality control during production from raw materials to finished products with inspection points
- e) Procedures or instructions for:
 - heat treatment and associated control
 - non destructive tests of weld joint and finished links
 - type, extent and criteria
 - non destructive tests of stud weld, as applicable.

Where any part of the manufacturing process is assigned to other companies or other manufacturing plants, additional information required by the Society is to be included.

1.2.2 Cast chain cables

The following information is to be supplied by the manufacturer:

- a) Steel grade specification, size range and drawing of common chain link
- b) Description of steelmaking and casting process
- c) Heat treatment furnaces, type, equipment for temperature monitoring and its calibration

- d) Description of quality control during production with inspection points
- e) Procedures or instructions for:
 - heat treatment and associated control
 - non destructive tests of finished links
 - type, extent and acceptance criteria.

Where any part of the manufacturing process is assigned to other companies or other manufacturing plants, additional information required by the Society is to be included.

1.2.3 Forged accessories

The following information is to be supplied by the manufacturer:

- a) Steel grade specification, size range and drawing of each type of accessory
- b) Raw materials (ingots, round bars...) suppliers name & address
- c) Description of forging process
- d) Heat treatment furnaces, type, equipment for temperature monitoring and its calibration
- e) Description of quality control during production from raw materials to finished products with inspection points
- f) Procedures or instructions for:
 - heat treatment and associated control
 - non destructive tests of finished products
 - type, extent and acceptance criteria.

Where any part of the manufacturing process is assigned to other companies or other manufacturing plants, additional information required by the Society is to be included.

1.2.4 Cast accessories

The following information is to be supplied by the manufacturer:

- a) Steel grade specification, size range and drawing of each accessory
- b) Description of steelmaking and casting process
- c) Heat treatment furnaces, type, equipment for temperature monitoring and its calibration
- d) Description of quality control during production
- e) Procedures or instructions for:
 - heat treatment and associated control
 - non destructive tests of finished products
 - type, extent and criteria.

Where any part of the manufacturing process is assigned to other companies or other manufacturing plants, additional information required by the Society is to be included.

1.3 Documents to be submitted for changing the approval conditions

1.3.1 The manufacturer has to submit to the Society the documents required in [1.2] together with the request of changing the approval conditions, in case of the following:

- a) Change of the manufacturing process
- b) Change of the range of approval (maximum diameter, steel grade...).

However, where the documents are duplicated by the ones at the previous approval for the same type of product, part or all of the documents may be omitted except the approval test program.

1.4 Approval survey

1.4.1 The approval tests are to be witnessed by the Surveyor at the manufacturer's plant and the execution of the plant inspection in operation may be required by the Surveyor during the visit for the approval.

If the testing facilities are not available at the works, the tests are to be carried out at laboratories accepted by the Society.

1.5 Selection of the test product

1.5.1 Flash butt welded chain cable

One chain length with suitable number of links for the approval tests is to be selected as follows:

- Maximum diameter to be approved
- The length is to be heat treated using current production equipment and procedures.

1.5.2 Cast chain cable

One chain length with suitable number of links for approval tests is to be selected as follows:

- Maximum diameter to be approved
- The length is to be heat treated using current production equipment and procedures.

1.5.3 Forged or cast accessories

Suitable quantity of each type of accessories is to be selected as follows:

- Maximum diameter to be approved
- The items are to be heat treated using current production equipment and procedures.

1.6 Extent of the approval tests

1.6.1 The extent of the test program is specified in [1.7]; it may be modified on the basis of the preliminary information submitted by the manufacturer. In particular a reduction of the approval test program may be accepted by the Society taking into account approval already granted by other Classification Societies and documentation of approval tests performed.

Where the number of tests differs from those shown in [1.7], the program is to be confirmed by the Society before the tests are carried out.

1.6.2 Flash butt welded chain cable

Each grade and type of chain is to be tested.

Approval for studlink chain cable of any grade may cover approval for studless chain cable of same diameter provided that the method of manufacture and condition of supply are similar.

Approval for common links may cover approval for enlarged link and end link up to tested diameter provided that the method of manufacture and condition of supply are similar.

1.6.3 Cast chain cable

Each grade and type of chain is to be tested.

Approval for studlink chain cable of any grade may cover approval for studless chain cable of same diameter provided that the method of manufacture and condition of supply are similar.

Approval for common links may cover approval for enlarged link and end link up to tested diameter provided that the method of manufacture and condition of supply are similar.

1.6.4 Forged or cast accessories

Each type of manufacturing process is to be tested.

For a type of accessory, approval for any grade of steel may cover approval for lower strength grades provided that the steel type, method of manufacture and condition of supply are similar.

Each type of accessory is to be tested. However approval for anchor shackle may cover approval for joining shackle up to the same diameter provided that the method of manufacture and condition of supply are the same.

1.7 Approval tests and documentation

1.7.1 Approval tests for flash butt welded chain cables

In addition to test reports, documentation relative to the manufacturing process parameters of the length tested is to be supplied and is to include:

- Heating and hot bending of round bars
- Welding parameters
- Stud insertion and all information about stud welding, as applicable
- Heat treatment.

The tests to be carried out are indicated in Tab 1.

1.7.2 Approval tests for cast chain cables

The tests to be carried out are indicated in Tab 2.

1.7.3 Approval tests for cast or forged accessories

The tests to be carried out are indicated in Tab 3.

Table 1 : Approval tests for butt welded chain cables

Type of test	Position of the samples and direction of the test specimens	Remarks
All the relevant routine tests required in NR216 Materials and Welding, Ch 4, Sec 1 for chain length (proof test, break tests,...) and for links (mechanical properties) are to be performed in addition to the following tests:		
Chemical analysis	From tensile test specimen	Complete analysis (C, Mn, Si, S, P, N, Cu, Cr, Ni, Mo, Al, Ti, Nb, V, Sn, As, Sb...)
Tensile test	One specimen clear of the weld One specimen across the weld Both taken at 1/3 radius below surface	
Impact tests	One set from side opposite to the weld One set from bent area One set with notch in the weld One set with notch in HAZ	At +20°C and 0°C for grade Q1 At +20°C, 0°C and -20°C for grades Q2 and Q3
Bend tests	Two links	Full link to be tested at bending angle 180° (weld seam in the middle of bent area) Alternative cross weld bend tests at 180° on 4t mandrel may be agreed
Macro examination and hardness tests	Longitudinal section showing the weld	Hardness tests from base metal to weld metal for quenched and tempered grades
Micro examination	Weld metal Heat affected zone Bent area of common link	Magnification 100 and 500

Table 2 : Approval tests for cast chain cable

Type of test	Position of the samples and direction of the test specimens	Remarks
All the relevant routine tests required in NR216 Materials and Welding, Ch 4, Sec 1 for chain length (proof test, break tests,...) and for links (mechanical properties) are to be performed in addition to the following tests:		
Chemical analysis	From tensile test specimen	Complete analysis (C, Mn, Si, S, P, N, Cu, Cr, Ni, Mo, Al, Ti, Nb, V, Sn, As, Sb...)
Tensile test	At 1/3 radius below surface	
Impact tests	At 1/3 radius below surface	At +20°C and 0°C for grade Q1 At +20°C, 0°C and -20°C for grades Q2 and Q3
Macro examination	Longitudinal section	Hardness tests from base metal to weld metal for quenched and tempered grades
Micro examination	At 1/3 radius below surface	Magnification 100 and 500

Table 3 : Approval tests for cast or forged accessories

Type of test	Position of the samples and direction of the test specimens	Remarks
All the relevant routine tests required in NR216 Materials and Welding, Ch 4, Sec 1 for chain length (proof test, break tests,...) and for links (mechanical properties) are to be performed in addition to the following tests:		
Chemical analysis	From tensile test specimen	Complete analysis (C, Mn, Si, S, P, N, Cu, Cr, Ni, Mo, Al, Ti, Nb, V, Sn, As, Sb...)
Tensile test	At 1/3 radius below surface	On each item of the accessory
Impact tests	At 1/3 radius below surface	On each item of the accessory At +20°C and 0°C for grade Q1 At +20°C, 0°C and -20°C for grades Q2 and Q3
Macro examination	Longitudinal section	
Micro examination	At 1/3 radius below surface	Magnification 100 and 500

1.7.4 Results and records

All the results, which are to comply with the requirements of NR 216 Materials and Welding and approved material specification, are evaluated for the approval; depending on the results, particular limitations or testing conditions, as deemed appropriate, may be specified in the approval document.

All the information required under [1.2] is to be collected by the manufacturer and put in the technical documenta-

tion which will include all the results of the tests and operation records relevant to alloy making, casting, and, heat treatment of each tested product.

When steel is cast in a work other than where the ship chain cables and/or accessories are manufactured, the steelmaker's certificate stating the manufacturing process, the grade of steel, the cast number and the relevant ladle analysis is to be provided for each tested product

APPENDIX 1

EVALUATION OF K_{CA}

1 Evaluation

1.1

1.1.1 The straight-line approximation of arrhenius plot for valid K_{ca} data by interpolation method are to comply with either the following (a) or (b):

- a) The evaluation temperature of K_{ca} (i.e. $-10^{\circ}C$) is located between the upper and lower limits of the arrest temperature, with the K_{ca} corresponding to the evaluation temperature not lower than the required K_{ca} (e.g. $6000\text{ N/mm}^{3/2}$ or $8000\text{ N/mm}^{3/2}$), as shown in Fig 1.

Figure 1 : Example for evaluation of K_{ca} at $-10^{\circ}C$

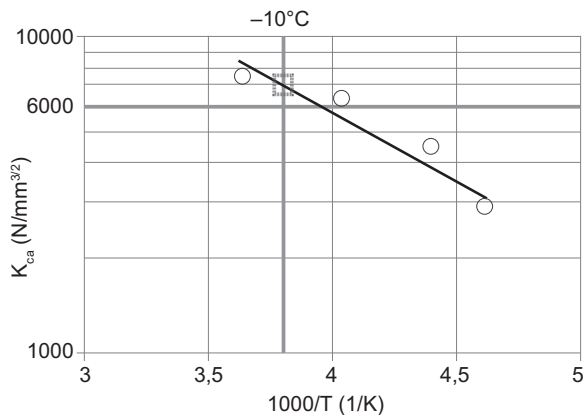

- b) The temperature corresponding to the required K_{ca} (e.g. $6000\text{ N/mm}^{3/2}$ or $8000\text{ N/mm}^{3/2}$) is located between the upper and lower limits of the arrest temperature, with the temperature corresponding to the required K_{ca} not higher than the evaluation temperature (i.e. $-10^{\circ}C$), as shown in Fig 2.

If both of (a) and (b) above are not satisfied, conduct additional tests to satisfy this condition.

Figure 2 : Example for evaluation of temperature corresponding to the required K_{ca}

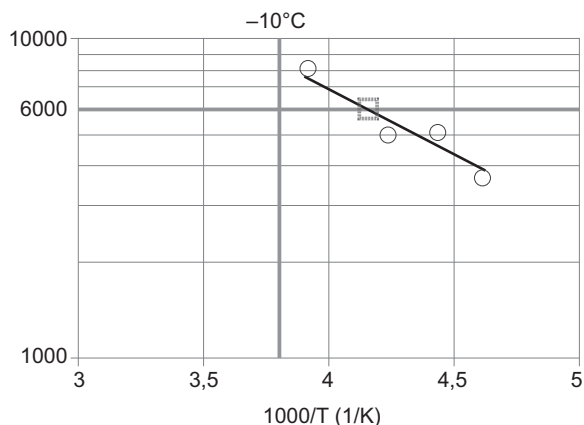

APPENDIX 2

CRACK ARREST TEMPERATURE (CAT) TEST

Symbols

t	: Test specimen thickness, in mm
L	: Test specimen length, in mm
W	: Test specimen width, in mm
a_{MN}	: Machined notch length on specimen edge, in mm
L_{SG}	: Side groove length on side surface from the specimen edge, in mm. L_{SG} is defined as a groove length with constant depth except a curved section in depth at side groove end
d_{SG}	: Side groove depth in section with constant depth, in mm
L_{EB-min}	: Minimum length between specimen edge and electron beam re-melting zone front, in mm
$L_{EB-s1, -s2}$: Length between specimen edge and electron beam re-melting zone front appeared on both specimen side surfaces, in mm
L_{LTG}	: Local temperature gradient zone length for brittle crack runaway, in mm
a_{arrest}	: Arrested crack length, in mm
T_{target}	: Target test temperature, in °C
T_{test}	: Defined test temperature, in °C
T_{arrest}	: Target test temperature at which valid brittle crack arrest behaviour is observed, in °C
σ	: Applied test stress at cross section of $W t$, in N/mm^2
SMYS	: Specified minimum yield strength of the tested steel grade to be approved, in N/mm^2
CAT	: Crack arrest temperature, the lowest temperature, T_{arrest} at which running brittle crack is arrested, in °C.

1 Scope of application

1.1

1.1.1 This Appendix is to be applied according to the scope defined in NR216, Ch 2, Sec 1, [4].

1.1.2 This Appendix specifies the requirements for test procedures and test conditions when using the isothermal crack arrest test to determine a valid test result under isothermal conditions and in order to establish the crack arrest temperature (CAT). This Appendix is applicable to steels with thickness over 50mm and not greater than 100 mm

1.1.3 This method uses an isothermal temperature in the test specimen being evaluated. Unless otherwise specified in this Appendix, the other test parameters are to be in accordance with ISO 20064-2019.

1.1.4 Tab 14 of NR216, Ch 2, Sec 1 gives the relevant requirements for the brittle crack arrest property described by the crack arrest temperature (CAT).

1.1.5 The manufacturer is to submit the test procedure to the Classification Society for review prior to testing.

2 Testing equipment

2.1

2.1.1 The test equipment to be used is to be of the hydraulic type of sufficient capacity to provide a tensile load equivalent to 2/3 of SMYS of the steel grade to be approved.

2.1.2 The temperature control system is to be equipped to maintain the temperature in the specified region of the specimen within $\pm 2^\circ\text{C}$ from T_{target} .

2.1.3 Methods for initiating the brittle crack may be of drop weight type, air gun type or double tension tab plate type.

2.1.4 The detailed requirements for testing equipment are specified in 5 of ISO 20064.

3 Test specimens

3.1 Impact type crack initiation

3.1.1 Test specimens are to be in accordance with 6 of ISO 20064, unless otherwise specified in this Appendix.

3.1.2 Specimen dimensions are shown in Fig 1. The test specimen width, W shall be 500 mm. The test specimen length, L shall be equal to or greater than 500 mm.

3.1.3 V-shape notch for brittle crack initiation is machined on the specimen edge of the impact side. The whole machined notch length shall be equal to 29 mm with a tolerance range of ± 1 mm.

3.1.4 Requirements for side grooves are described in [3.4].

3.2 Double tension type crack initiation

3.2.1 Reference shall be made to Annex D of ISO 20064 for the shape and sizes in secondary loading tab and secondary loading method for brittle crack initiation.

3.2.2 In a double tension type test, the secondary loading tab plate may be subject to further cooling to enhance an easy brittle crack initiation.

Figure 1 : Test specimen dimensions for an impact type specimen

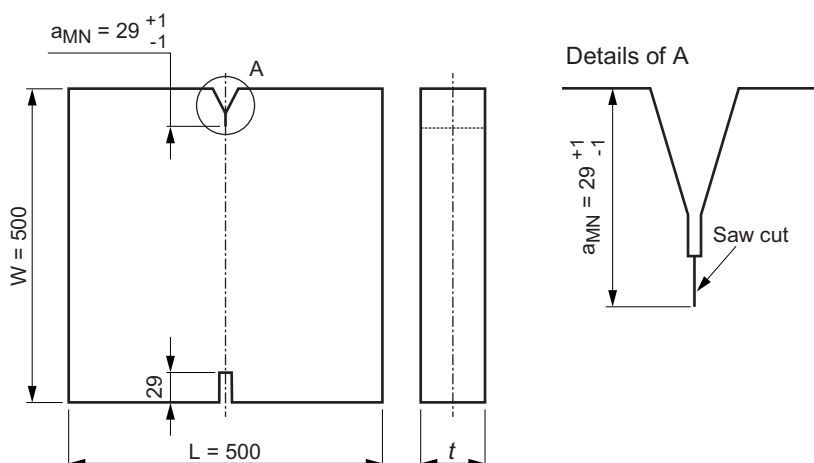

Saw cut notch radius may be machined in the range 0,1 mmR and 1 mmR in order to control a brittle crack initiation at test.

3.3 Embrittled zone setting

3.3.1 An embrittled zone shall be applied to ensure the initiation of a running brittle crack. Either Electron Beam Welding (EBW) or Local Temperature Gradient (LTG) may be adopted to facilitate the embrittled zone.

3.3.2 In EBW embrittlement, electron beam welding is applied along the expected initial crack propagation path, which is the centre line of the specimen in front of the machined V- notch.

3.3.3 The complete penetration through the specimen thickness is required along the embrittled zone. One side EBW penetration is preferable, but dual sides EB penetration may be also adopted when the EBW power is not enough to achieve the complete penetration by one side EBW.

3.3.4 The EBW embrittlement is recommended to be prepared before specimen contour machining.

3.3.5 In EBW embrittlement, zone shall be of an appropriate quality.

Note 1: EBW occasionally behaves in an un-stable manner at start and end points. EBW line is recommended to start from the embrittled zone tip side to the specimen edge with an increasing power control or go/return manner at start point to keep the stable EBW.

3.3.6 In LTG system, the specified local temperature gradient between machined notch tip and isothermal test region is regulated after isothermal temperature control. LTG temperature control is to be achieved just before brittle crack initiation, nevertheless the steady temperature gradient through the thickness shall be ensured.

3.4 Side grooves

3.4.1 Side grooves on side surface can be machined along the embrittled zone to keep brittle crack propagation straight. Side grooves shall be machined in the specified cases as specified in this section.

3.4.2 In EBW embrittlement, side grooves are not necessarily mandatory. Use of EBW avoids the shear lips. However, when shear lips are evident on the fractured specimen, e.g. shear lips over 1 mm in thickness in either side then side grooves should be machined to suppress the shear lips.

3.4.3 In LTG embrittlement, side grooves are mandatory. Side grooves with the same shape and size shall be machined on both side surfaces.

3.4.4 The length of side groove, L_{SG} shall be no shorter than the sum of the required embrittled zone length of 150 mm.

3.4.5 When side grooves would be introduced, the side groove depth, the tip radius and the open angle are not regulated, but are adequately selected in order to avoid any shear lips over 1 mm thickness in either side. An example of side groove dimensions are shown in Fig 2.

3.4.6 Side groove end shall be machined to make a groove depth gradually shallow with a curvature larger than or equal to groove depth, d_{SG} . Side groove length, L_{SG} is defined as a groove length with constant depth except a curved section in depth at side groove end.

3.5 Nominal length of embrittled zone

3.5.1 The length of embrittled zone shall be nominally equal to 150 mm in both systems of EBW and LTG.

3.5.2 EBW zone length is regulated by three measurements on the fracture surface after test as shown in Fig 3, L_{EB-min} between specimen edge and EBW front line, and L_{EB-s1} and L_{EB-s2} .

3.5.3 The minimum length between specimen edge and EBW front line, L_{EB-min} should be no smaller than 150 mm. However, it can be acceptable even if L_{EB-min} is no smaller than $150\text{ mm} - 0,2 t$, where t is specimen thickness. When L_{EB-min} is smaller than 150 mm, a temperature safety margin shall be considered into T_{test} (See [7.1.2]).

Figure 2 : Side groove configuration and dimensions

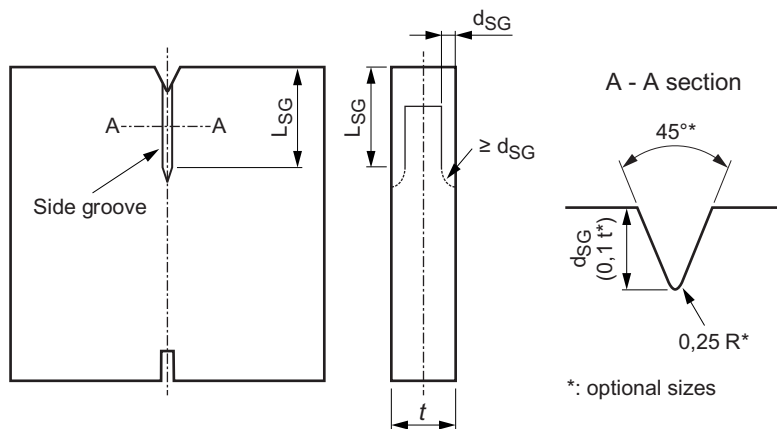
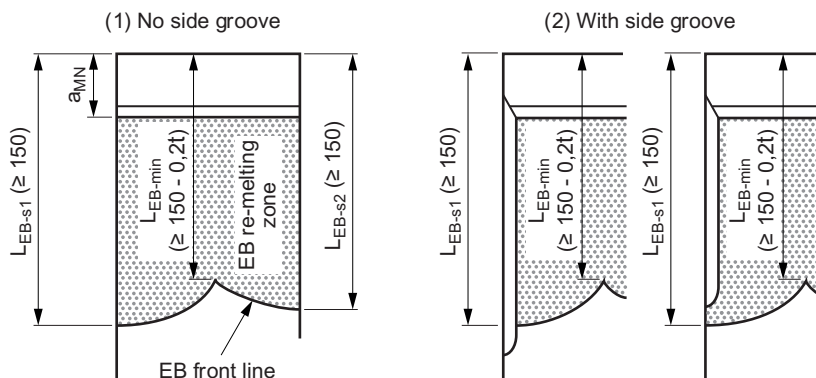

Figure 3 : Definition of EBW length



3.5.4 Another two are the lengths between specimen edge and EBW front appeared on both side surfaces, as denoted with L_{EB-s1} and L_{EB-s2} . Both of L_{EB-s1} and L_{EB-s2} shall be no smaller than 150 mm.

3.5.5 In LTG system, LLTG is set as 150 mm.

3.6 Tab plate/pin chuck details and welding of test specimen to tab plates

3.6.1 The configuration and size of tab plates and pin chucks shall be referred to 6.2 of ISO 20064. The welding distortion in the integrated specimen, which is welded with specimen, tab plates and pin chucks, shall be also within the requirement in 6.3 of ISO 20064.

4 Test method

4.1 Preloading

4.1.1 Preloading at room temperature can be applied to avoid unexpected brittle crack initiation at test. The applied load value shall be no greater than the test stress. Preloading can be applied at higher temperature than ambient temperature when brittle crack initiation is expected at preloading process. However, the specimen shall not be subjected to temperature higher than 100°C.

4.2 Temperature measurement and control

4.2.1 Temperature control plan showing the number and position of thermocouples is to be in accordance with this section.

4.2.2 Thermocouples are to be attached to both sides of the test specimen at a maximum interval of 50 mm in the whole width and in the longitudinal direction at the test specimen centre position (0,5 W) within the range of ± 100 mm from the centreline in the longitudinal direction, refer to Fig 4.

4.2.3 For EBW embrittlement

- The temperatures of the thermocouples across the range of 0,3W~0,7W in both width and longitudinal directions are to be controlled within $\pm 2^\circ\text{C}$ of the target test temperature, T_{target} .
- When all measured temperatures across the range of 0,3W~0,7W have reached T_{target} , steady temperature control shall be kept at least for $10 + 0,1 t$ (mm) minutes to ensure a uniform temperature distribution into mid-thickness prior to applying test load.
- The machined notch tip can be locally cooled to easily initiate brittle crack. Nevertheless, the local cooling shall not disturb the steady temperature control across the range of 0,3W~0,7W.

Figure 4 : Locations of temperature measurement

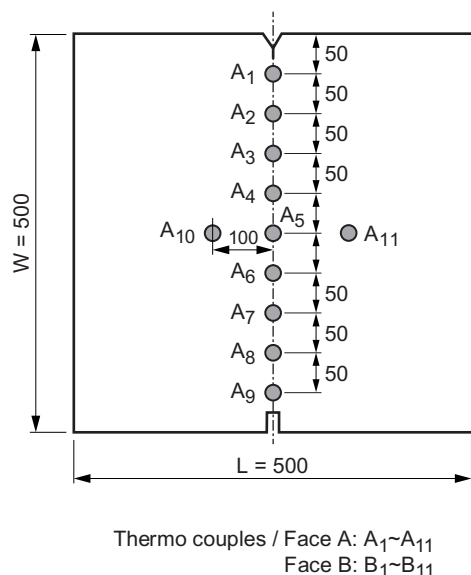
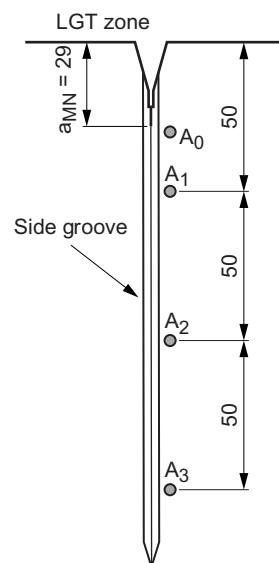

Figure 5 : Detail of LTG zone and additional thermocouple A₀



4.2.4 For LTG embrittlement:

- a) In LTG system, in addition to the temperature measurements shown in Fig 4, the additional temperature measurement at the machine notch tip, A₀ and B₀ is required. Thermocouples positions within LTG zone are shown in Fig 5.
- b) The temperatures of the thermocouples across the range of 0,3W~0,7W in both width and longitudinal directions are to be controlled within ± 2°C of the target test temperature, T_{target}. However, the temperature measurement at 0,3W (location of A₃ and B₃) shall be in accordance with item f) below.
- c) Once the all measured temperatures across the range of 0,3W~0,7W have reached T_{target}, steady temperature control shall be kept at least for 10 + 0,1 t (mm) minutes to ensure a uniform temperature distribution into mid-thickness, then the test load is applied.
- d) LTG is controlled by local cooling around the machined notch tip. LTG profile shall be recorded by the temperature measurements from A₀ to A₃ shown in Fig 6.
- e) LTG zone is established by temperature gradients in three zones, Zone I, Zone II and Zone III. The acceptable range for each temperature gradient is listed Tab 1.
- f) Two temperature measurements at A₂, B₂ and A₃, B₃ shall be satisfied the following requirements:
 $T \text{ at } A_3, T \text{ at } B_3 < T_{\text{target}} - 2^\circ\text{C}$
 $T \text{ at } A_2 < T \text{ at } A_3 - 5^\circ\text{C}$
 $T \text{ at } B_2 < T \text{ at } B_3 - 5^\circ\text{C}$
- g) No requirements for T at A₀ and T at A₁ temperatures when T at A₃ and T at A₂ satisfy the requirements above. Face B is the same.
- h) The temperatures from A₀, B₀ to A₃, B₃ should be decided at test planning stage refer to Tab 1 which gives the recommended temperature gradients in three zones, Zone I, Zone II and Zone III in LTG zone.

- i) The temperature profile in LTG zone mentioned above shall be ensured after holding time at least for 10 + 0,1 t (mm) minutes to ensure a uniform temperature distribution into mid-thickness before brittle crack initiation.
- j) The acceptance of LTG in the test shall be decided from Tab 1 based on the measured temperatures from A₀ to A₃.

Table 1 : Acceptable LTG range

Zone	Location from edge, in mm	Acceptable range of temperature gradient, in °C/mm
Zone I	29 – 50	2,00 – 2,30
Zone II	50 – 100	0,25 – 0,60
Zone III (1)	100 – 150	0,10 – 0,20
(1) The Zone III arrangement is mandatory		

4.2.5 For double tension type crack initiation specimen:

Temperature control and holding time at steady state shall be the same as the case of EBW embrittlement specified in [4.2.3] or the case of LTG embrittlement specified in [4.2.4].

4.3 Loading and brittle crack initiation

4.3.1 Prior to testing, a target test temperature (T_{target}) shall be selected.

4.3.2 Test procedures are to be in accordance with 8 of ISO 20064 except that the applied stress is to be 2/3 of SMYS of the steel grade tested.

4.3.3 The test load shall be held at the test target load or higher for a minimum of 30 seconds prior to crack initiation.

4.3.4 Brittle crack can be initiated by impact or secondary tab plate tension after all of the temperature measurements and the applied force are recorded.

Figure 6 : Schematic temperature gradient profile in LTG zone

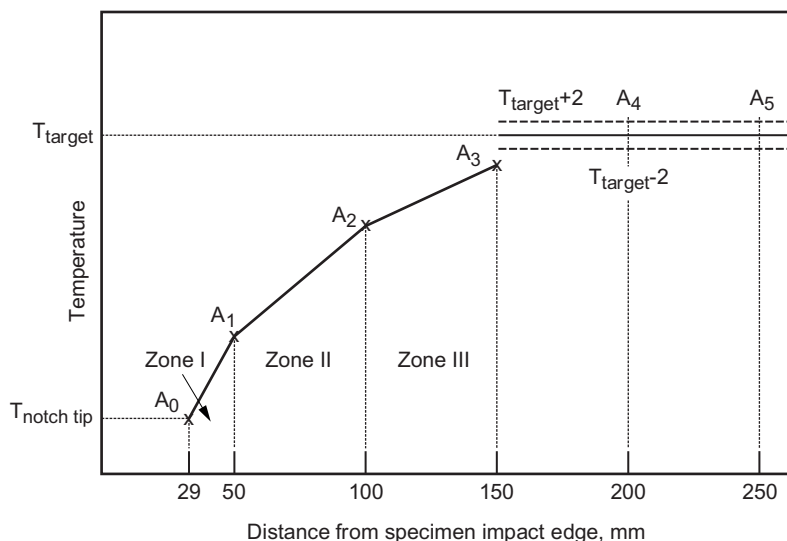

5 Measurements after test and test validation judgement

5.1 Brittle crack initiation and validation

5.1.1 If brittle crack spontaneously initiates before the test force is achieved or the specified hold time at the test force is not achieved, the test shall be invalid.

5.1.2 If brittle crack spontaneously initiates without impact or secondary tab tension but after the specified time at the test force is achieved, the test is considered as a valid initiation. The following validation judgments of crack path and fracture appearance shall be examined.

5.2 Crack path examination and validation

5.2.1 When brittle crack path in embrittled zone deviates from EBW line or side groove in LTG system due to crack deflection and/or crack branching, the test shall be considered as invalid.

5.2.2 All of the crack path from embrittled zone end shall be within the range shown in Fig 7. If not, the test shall be considered as invalid.

5.3 Fracture surface examination, crack length measurement and their validation

5.3.1 Fracture surface shall be observed and examined. The crack "initiation" and "propagation" are to be checked for validity and judgements recorded. The crack "arrest" positions are to be measured and recorded.

5.3.2 When crack initiation trigger point is clearly detected at side groove root, other than the V-notch tip, the test shall be invalid.

5.3.3 In EBW embrittlement setting, EBW zone length is quantified by three measurements of L_{EB-s1} , L_{EB-s2} and L_{EB-min} , which are defined in [3.5]. When either or both of L_{EB-s1} and

L_{EB-s2} are smaller than 150 mm, the test shall be invalid. When L_{EB-min} is smaller than $150\text{ mm} - 0,2 t$, the test shall be invalid.

5.3.4 When the shear lip with thickness over 1mm in either side near side surfaces of embrittled zone are visibly observed independent of the specimens with or without side grooves, the test shall be invalid.

5.3.5 In EBW embrittlement setting, the penetration of brittle crack beyond the EBW front line shall be visually examined. When any brittle fracture appearance continued from the EB front line is not detected, the test shall be invalid.

5.3.6 The weld defects in EBW embrittled zone shall be visually examined. If detected, it shall be quantified. A projecting length of defect on the thickness line through EB weld region along brittle crack path shall be measured, and the total occupation ratio of the projected defect part to the total thickness is defined as defect line fraction (See Fig 8). When the defects line fraction is larger than 10%, the test shall be invalid.

Figure 7 : Allowable range of main crack propagation path

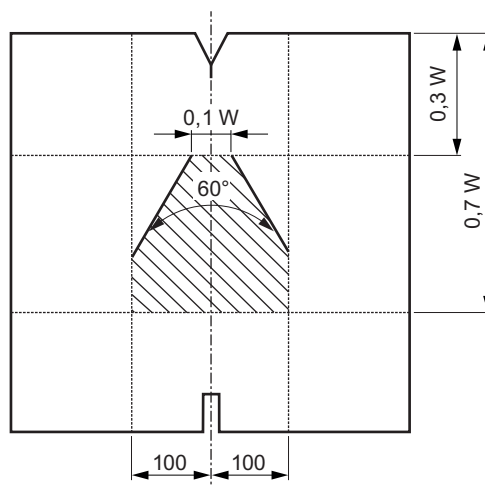
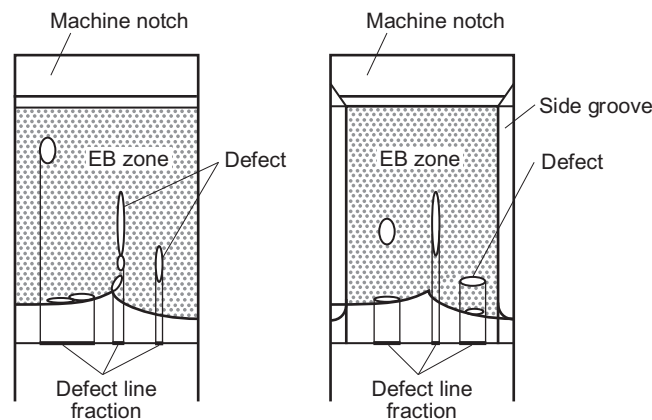

Figure 8 : Counting procedure of defect line fraction



5.3.7 In EBW embrittlement by dual sides' penetration, a gap on embrittled zone fracture surface which is induced by miss meeting of dual fusion lines is visibly detected at an overlapped line of dual side penetration, the test shall be invalid.

6 Judgement of “arrest” or “propagate”

6.1

6.1.1 The final test judgment of “arrest”, “propagate” or “invalid” is decided by the following requirements of [6.1.2] through [6.1.6].

6.1.2 If initiated brittle crack is arrested and the tested specimen is not broken into two pieces, the fracture surfaces should be exposed with the procedures specified in 6.3 and 8.3 and 8.4 of ISO 20064.

6.1.3 When the specimen was not broken into two pieces during testing, the arrested crack length, a_{arrest} shall be measured on the fractured surfaces. The length from the specimen edge of impact side to the arrested crack tip (the longest position) is defined as a_{arrest} .

6.1.4 For LTG and EBW, a_{arrest} shall be greater than LLTG and $L_{\text{EB-s1}}$, $L_{\text{EB-s2}}$ or $L_{\text{EB-min}}$. If not, the test shall be considered as invalid.

6.1.5 Even when the specimen was broken into two pieces during testing, it can be considered as “arrest” when brittle crack re-initiation is clearly evident. Even in the fracture surface all occupied by brittle fracture, when a part of brittle crack surface from embrittled zone is continuously surrounded by thin ductile tear line, the test can be judged as re-initiation behaviour. If so, the maximum crack length of the part surrounded tear line can be measured as a_{arrest} . If re-initiation is not visibly evident, the test is judged as “propagate”.

6.1.6 The test is judged as “arrest” when the value of a_{arrest} is no greater than 0,7W. If not, the test is judged as “propagate”.

7 T_{test} , T_{arrest} and CAT determination

7.1 T_{test} determination

7.1.1 It shall be ensured on the thermocouple measured record that all temperature measurements across the range of 0,3W~0,7W in both width and longitudinal direction are in the range of $T_{\text{target}} \pm 2^\circ\text{C}$ at brittle crack initiation. If not, the test shall be invalid. However, the temperature measurement at 0,3W (location of A_3 and B_3) in LTG system shall be exempted from this requirement.

7.1.2 If $LE_{\text{B-min}}$ in EBW embrittlement is no smaller than 150 mm, T_{test} can be defined to equal with T_{target} . If not, T_{test} shall be equalled with $T_{\text{target}} + 5^\circ\text{C}$.

7.1.3 In LTG embrittlement, T_{test} can be equalled with T_{target} .

7.1.4 The final arrest judgment at T_{test} is concluded by at least two tests at the same test condition which are judged as “arrest”.

7.2 T_{arrest} determination

7.2.1 When at least repeated two “arrest” tests appear at the same T_{target} , brittle crack arrest behaviour at T_{target} will be decided ($T_{\text{arrest}} = T_{\text{target}}$). When a “propagate” test result is included in the multiple test results at the same T_{target} , the T_{target} cannot to be decided as T_{arrest} .

7.3 CAT determination

7.3.1 When CAT is determined, one “propagate” test is needed in addition to two “arrest” tests. The target test temperature, T_{target} for “propagate” test is recommended to select 5°C lower than T_{arrest} . The minimum temperature of T_{arrest} is determined as CAT.

7.3.2 With only the “arrest” tests, without “propagation” test, it is decided only that CAT is lower than T_{test} in the two “arrest” tests, i.e. not deterministic CAT.

8 Reporting

8.1

8.1.1 The following items are to be reported:

- a) Test material:
grade and thickness
- b) Test machine capacity
- c) Test specimen dimensions:
thickness t , width W and length L , notch details and length a_{MN} , side groove details if machined
- d) Embrittled zone type:
EBW or LTG embrittlement
- e) Integrated specimen dimensions:
tab plate thickness, tab plate width, integrated specimen unit length including the tab plates, and distance between the loading pins, angular distortion and linear misalignment
- f) Brittle crack trigger information:
impact type or double tension. If impact type, drop weight type or air gun type, and applied impact energy
- g) Test conditions; Applied load; preload stress, test stress:
judgements for preload stress limit, hold time requirement under steady test stress
- h) Test temperature:
complete temperature records with thermocouple positions for measured temperatures (figure and/or table) and target test temperature:
 - judgements for temperature scatter limit in isothermal region
 - judgement for local temperature gradient requirements and holding time requirement after steady local temperature gradient before brittle crack trigger, if LTG system is used
- i) Crack path and fracture surface: tested specimen photos showing fracture surfaces on both sides and crack path side view; Mark at "embrittled zone tip" and "arrest" positions

- judgment for crack path requirement
- judgment for cleavage trigger location (whether side groove edge or V-notch edge)

j) Embrittled zone information:

- when EBW is used: L_{EB-s1} , L_{EB-s2} and L_{EB-min} :
 - judgement for shear lip thickness requirement
 - judgement whether brittle fracture appearance area continues from the EBW front line
 - judgement for EBW defects requirement
 - judgement for EBW lengths, L_{EB-s1} , L_{EB-s2} and L_{EB-min} requirements
- when LTG is used: LLTG
judgment for shear lip thickness requirement

Test results:

- when the specimen did not break into two pieces after brittle crack trigger, arrested crack length a_{arrest}
- when the specimen broke into two pieces after brittle crack trigger:
judgement whether brittle crack re-initiation or not
If so, arrested crack length a_{arrest} :
 - judgement for a_{arrest} in the valid range
($0,3W < a_{arrest} \leq 0,7W$)
 - final judgement either "arrest", "propagate" or "invalid"

k) Dynamic measurement results:

history of crack propagation velocity, and strain change at pin chucks, if needed.

9 Use of test for material qualification testing

9.1

9.1.1 Where required, the method can also be used for determining the lowest temperature at which a steel can arrest a running brittle crack (the determined CAT) as the material property characteristic in accordance with [7.3].



**BUREAU
VERITAS**

Shaping a World of Trust

Marine & Offshore
Le Triangle de l'Arche - 8 Cours du Triangle - CS 50101
92937 Paris La Defense Cedex - France
Tel: + 33 (0)1 55 24 70 00
<https://marine-offshore.bureauveritas.com/bv-rules>
© 2021 Bureau Veritas – All rights reserved