



**BUREAU
VERITAS**

Rules for the Classification of Steel Ships

NR 467

AMENDMENTS

January 2019

These sheets contain amendments within the following Sections of July 2018 issue of the *Rules for the Classification of Steel Ships*.

These amendments are effective from January 1st, 2019.

Part	Volume	Chapter	Section / Appendix
Part A	<i>NR 467 A1 DT R15 E</i>	Ch 1	Sec 1, Sec 2
		Ch 2	Sec 2, Sec 3, App 3
		Ch 3	Sec 1, Sec 2, Sec 3, Sec 4
		Ch 4	Sec 2, Sec 3, Sec 4, Sec 5, Sec 7, Sec 9
		Ch 5	Sec 1, Sec 7, Sec 10
Part B	<i>NR 467 B1 DT R10 E</i>	Ch 2	Sec 3
		Ch 4	Sec 3, Sec 6, Sec 7
		Ch 7	Sec 3
		Ch 8	Sec 2, Sec 4, Sec 10,
		Ch 9	Sec 1, Sec 3, Sec 4, App 2
		Ch 11	Sec 1, Sec 3
Part C	<i>NR 467 C1 DT R10 E</i>	Ch 1	Sec 2, Sec 8, Sec 10, Sec 11, App 3
		Ch 2	Sec 4, Sec 5, Sec 7, Sec 13, Sec 14
		Ch 4	Sec 2, Sec 8, Sec 11, Sec 14

Continued page 3



GENERAL CONDITIONS

1. INDEPENDENCE OF THE SOCIETY AND APPLICABLE TERMS

- 1.1 The Society shall remain at all times an independent contractor and neither the Society nor any of its officers, employees, servants, agents or subcontractors shall be or act as an employee, servant or agent of any other party hereto in the performance of the Services.
- 1.2 The operations of the Society in providing its Services are exclusively conducted by way of random inspections and do not, in any circumstances, involve monitoring or exhaustive verification.
- 1.3 The Society acts as a services provider. This cannot be construed as an obligation bearing on the Society to obtain a result or as a warranty. The Society is not and may not be considered as an underwriter, broker in Unit's sale or chartering, expert in Unit's valuation, consulting engineer, controller, naval architect, designer, manufacturer, shipbuilder, repair or conversion yard, charterer or shipowner; none of them above listed being relieved of any of their expressed or implied obligations as a result of the interventions of the Society.
- 1.4 The Society only is qualified to apply and interpret its Rules.
- 1.5 The Client acknowledges the latest versions of the Conditions and of the applicable Rules applying to the Services' performance.
- 1.6 Unless an express written agreement is made between the Parties on the applicable Rules, the applicable Rules shall be the Rules applicable at the time of entering into the relevant contract for the performance of the Services.
- 1.7 The Services' performance is solely based on the Conditions. No other terms shall apply whether express or implied.

2. DEFINITIONS

- 2.1 "Certificate(s)" means classification or statutory certificates, attestations and reports following the Society's intervention.
- 2.2 "Certification" means the activity of certification in application of national and international regulations or standards, in particular by delegation from different governments that can result in the issuance of a Certificate.
- 2.3 "Classification" means the classification of a Unit that can result or not in the issuance of a classification Certificate with reference to the Rules. Classification is an appraisal given by the Society to the Client, at a certain date, following surveys by its surveyors on the level of compliance of the Unit to the Society's Rules or to the documents of reference for the Services provided. They cannot be construed as an implied or express warranty of safety, fitness for the purpose, seaworthiness of the Unit or of its value for sale, insurance or chartering.
- 2.4 "Client" means the Party and/or its representative requesting the Services.
- 2.5 "Conditions" means the terms and conditions set out in the present document.
- 2.6 "Industry Practice" means international maritime and/or offshore industry practices.
- 2.7 "Intellectual Property" means all patents, rights to inventions, utility models, copyright and related rights, trade marks, logos, service marks, trade dress, business and domain names, rights in trade dress or get-up, rights in goodwill or to sue for passing off, unfair competition rights, rights in designs, rights in computer software, database rights, topography rights, moral rights, rights in confidential information (including know-how and trade secrets), methods and protocols for Services, and any other intellectual property rights, in each case whether capable of registration, registered or unregistered and including all applications for and renewals, reversions or extensions of such rights, and all similar or equivalent rights or forms of protection in any part of the world.
- 2.8 "Parties" means the Society and Client together.
- 2.9 "Party" means the Society or the Client.
- 2.10 "Register" means the public electronic register of ships updated regularly by the Society.
- 2.11 "Rules" means the Society's classification rules and other documents. The Society's Rules take into account at the date of their preparation the state of currently available and proven technical minimum requirements but are not a standard or a code of construction neither a guide for maintenance, a safety handbook or a guide of professional practices, all of which are assumed to be known in detail and carefully followed at all times by the Client.
- 2.12 "Services" means the services set out in clauses 2.2 and 2.3 but also other services related to Classification and Certification such as, but not limited to: ship and company safety management certification, ship and port security certification, maritime labour certification, training activities, all activities and duties incidental thereto such as documentation on any supporting means, software, instrumentation, measurements, tests and trials on board. The Services are carried out by the Society according to the applicable referential and to the Bureau Veritas' Code of Ethics. The Society shall perform the Services according to the applicable national and international standards and Industry Practice and always on the assumption that the Client is aware of such standards and Industry Practice.
- 2.13 "Society" means the classification society 'Bureau Veritas Marine & Offshore SAS', a company organized and existing under the laws of France, registered in Nanterre under number 821 131 844, or any other legal entity of Bureau Veritas Group as may be specified in the relevant contract, and whose main activities are Classification and Certification of ships or offshore units.
- 2.14 "Unit" means any ship or vessel or offshore unit or structure of any type or part of it or system whether linked to shore, river bed or sea bed or not, whether operated or located at sea or in inland waters or partly on land, including submarines, hovercrafts, drilling rigs, offshore installations of any type and of any purpose, their related and ancillary equipment, subsea or not, such as well head and pipelines, mooring legs and mooring points or otherwise as decided by the Society.

3. SCOPE AND PERFORMANCE

- 3.1 Subject to the Services requested and always by reference to the Rules, the Society shall:
- review the construction arrangements of the Unit as shown on the documents provided by the Client;
 - conduct the Unit surveys at the place of the Unit construction;
 - class the Unit and enter the Unit's class in the Society's Register;
 - survey the Unit periodically in service to note whether the requirements for the maintenance of class are met.
- The Client shall inform the Society without delay of any circumstances which may cause any changes on the conducted surveys or Services.
- 3.2 The Society will not:
- declare the acceptance or commissioning of a Unit, nor its construction in conformity with its design, such activities remaining under the exclusive responsibility of the Unit's owner or builder;
 - engage in any work relating to the design, construction, production or repair checks, neither in the operation of the Unit or the Unit's trade, neither in any advisory services, and cannot be held liable on those accounts.

4. RESERVATION CLAUSE

- 4.1 The Client shall always: (i) maintain the Unit in good condition after surveys; (ii) present the Unit for surveys; and (iii) inform the Society in due time of any circumstances that may affect the given appraisal of the Unit or cause to modify the scope of the Services.
- 4.2 Certificates are only valid if issued by the Society.
- 4.3 The Society has entire control over the Certificates issued and may at any time withdraw a Certificate at its entire discretion including, but not limited to, in the following situations: where the Client fails to comply in due time with instructions of the Society or where the Client fails to pay in accordance with clause 6.2 hereunder.
- 4.4 The Society may at times and at its sole discretion give an opinion on a design or any technical element that would 'in principle' be acceptable to the Society. This opinion shall not presume on the final issuance of any Certificate or on its content in the event of the actual issuance of a Certificate. This opinion shall only be an appraisal made by the Society which shall not be held liable for it.

5. ACCESS AND SAFETY

- 5.1 The Client shall give to the Society all access and information necessary for the efficient performance of the requested Services. The Client shall be the sole responsible for the conditions of presentation of the Unit for tests, trials and surveys and the conditions under which tests and trials are carried out. Any information, drawing, etc. required for the performance of the Services must be made available in due time.
- 5.2 The Client shall notify the Society of any relevant safety issue and shall take all necessary safety-related measures to ensure a safe work environment for the Society or any of its officers, employees, servants, agents or subcontractors and shall comply with all applicable safety regulations.

6. PAYMENT OF INVOICES

- 6.1 The provision of the Services by the Society, whether complete or not, involve, for the part carried out, the payment of fees thirty (30) days upon issuance of the invoice.

6.2 Without prejudice to any other rights hereunder, in case of Client's payment default, the Society shall be entitled to charge, in addition to the amount not properly paid, interests equal to twelve (12) months LIBOR plus two (2) per cent as of due date calculated on the number of days such payment is delinquent. The Society shall also have the right to withhold Certificates and other documents and/or to suspend or revoke the validity of Certificates.

6.3 In case of dispute on the invoice amount, the undisputed portion of the invoice shall be paid and an explanation on the dispute shall accompany payment so that action can be taken to solve the dispute.

7. LIABILITY

- 7.1 The Society bears no liability for consequential loss. For the purpose of this clause consequential loss shall include, without limitation:
- Indirect or consequential loss;
 - Any loss and/or deferral of production, loss of product, loss of use, loss of bargain, loss of revenue, loss of profit or anticipated profit, loss of business and business interruption, in each case whether direct or indirect.
- The Client shall defend, release, save, indemnify, defend and hold harmless the Society from the Client's own consequential loss regardless of cause.
- 7.2 Except in case of wilful misconduct of the Society, death or bodily injury caused by the Society's negligence and any other liability that could not be, by law, limited, the Society's maximum liability towards the Client is limited to one hundred and fifty per-cents (150%) of the price paid by the Client to the Society for the Services having caused the damage. This limit applies to any liability of whatsoever nature and howsoever arising, including fault by the Society, breach of contract, breach of warranty, tort, strict liability, breach of statute.
- 7.3 All claims shall be presented to the Society in writing within three (3) months of the completion of Services' performance or (if later) the date when the events which are relied on were first discovered by the Client. Any claim not so presented as defined above shall be deemed waived and absolutely time barred.

8. INDEMNITY CLAUSE

8.1 The Client shall defend, release, save, indemnify and hold harmless the Society from and against any and all claims, demands, lawsuits or actions for damages, including legal fees, for harm or loss to persons and/or property tangible, intangible or otherwise which may be brought against the Society, incidental to, arising out of or in connection with the performance of the Services (including for damages arising out of or in connection with opinions delivered according to clause 4.4 above) except for those claims caused solely and completely by the gross negligence of the Society, its officers, employees, servants, agents or subcontractors.

9. TERMINATION

- 9.1 The Parties shall have the right to terminate the Services (and the relevant contract) for convenience after giving the other Party thirty (30) days' written notice, and without prejudice to clause 6 above.
- 9.2 In such a case, the Classification granted to the concerned Unit and the previously issued Certificates shall remain valid until the date of effect of the termination notice issued, subject to compliance with clause 4.1 and 6 above.
- 9.3 In the event where, in the reasonable opinion of the Society, the Client is in breach, or is suspected to be in breach of clause 16 of the Conditions, the Society shall have the right to terminate the Services (and the relevant contracts associated) with immediate effect.

10. FORCE MAJEURE

- 10.1 Neither Party shall be responsible or liable for any failure to fulfil any term or provision of the Conditions if and to the extent that fulfilment has been delayed or temporarily prevented by a force majeure occurrence without the fault or negligence of the Party affected and which, by the exercise of reasonable diligence, the said Party is unable to provide against.
- 10.2 For the purpose of this clause, force majeure shall mean any circumstance not being within a Party's reasonable control including, but not limited to: acts of God, natural disasters, epidemics or pandemics, wars, terrorist attacks, riots, sabotages, impositions of sanctions, embargoes, nuclear, chemical or biological contaminations, laws or action taken by a government or public authority, quotas or prohibition, expropriations, destructions of the worksite, explosions, fires, accidents, any labour or trade disputes, strikes or lockouts.

11. CONFIDENTIALITY

- 11.1 The documents and data provided to or prepared by the Society in performing the Services, and the information made available to the Society, are treated as confidential except where the information:
- is properly and lawfully in the possession of the Society;
 - is already in possession of the public or has entered the public domain, otherwise than through a breach of this obligation;
 - is acquired or received independently from a third party that has the right to disseminate such information;
 - is required to be disclosed under applicable law or by a governmental order, decree, regulation or rule or by a stock exchange authority (provided that the receiving Party shall make all reasonable efforts to give prompt written notice to the disclosing Party prior to such disclosure).
- 11.2 The Parties shall use the confidential information exclusively within the framework of their activity underlying these Conditions.
- 11.3 Confidential information shall only be provided to third parties with the prior written consent of the other Party. However, such prior consent shall not be required when the Society provides the confidential information to a subsidiary.
- 11.4 Without prejudice to sub-clause 11.1, the Society shall have the right to disclose the confidential information if required to do so under regulations of the International Association of Classifications Societies (IACS) or any statutory obligations.

12. INTELLECTUAL PROPERTY

- 12.1 Each Party exclusively owns all rights to its Intellectual Property created before or after the commencement date of the Conditions and whether or not associated with any contract between the Parties.
- 12.2 The Intellectual Property developed by the Society for the performance of the Services including, but not limited to drawings, calculations, and reports shall remain the exclusive property of the Society.

13. ASSIGNMENT

- 13.1 The contract resulting from these Conditions cannot be assigned or transferred by any means by a Party to any third party without the prior written consent of the other Party.
- 13.2 The Society shall however have the right to assign or transfer by any means the said contract to a subsidiary of the Bureau Veritas Group.

14. SEVERABILITY

- 14.1 Invalidity of one or more provisions does not affect the remaining provisions.
- 14.2 Definitions herein take precedence over other definitions which may appear in other documents issued by the Society.
- 14.3 In case of doubt as to the interpretation of the Conditions, the English text shall prevail.

15. GOVERNING LAW AND DISPUTE RESOLUTION

- 15.1 These Conditions shall be construed and governed by the laws of England and Wales.
- 15.2 The Parties shall make every effort to settle any dispute amicably and in good faith by way of negotiation within thirty (30) days from the date of receipt by either one of the Parties of a written notice of such a dispute.
- 15.3 Failing that, the dispute shall finally be settled under the Rules of Arbitration of the Maritime Arbitration Chamber of Paris ("CAMP"), which rules are deemed to be incorporated by reference into this clause. The number of arbitrators shall be three (3). The place of arbitration shall be Paris (France). The Parties agree to keep the arbitration proceedings confidential.

16. PROFESSIONAL ETHICS

- 16.1 Each Party shall conduct all activities in compliance with all laws, statutes, rules, economic and trade sanctions (including but not limited to US sanctions and EU sanctions) and regulations applicable to such Party including but not limited to: child labour, forced labour, collective bargaining, discrimination, abuse, working hours and minimum wages, anti-bribery, anti-corruption, copyright and trademark protection, personal data protection (<https://personaldataprotection.bureauveritas.com/privacypolicy>).
- Each of the Parties warrants that neither it, nor its affiliates, has made or will make, with respect to the matters provided for hereunder, any offer, payment, gift or authorization of the payment of any money directly or indirectly, to or for the use or benefit of any official or employee of the government, political party, official, or candidate.
- 16.2 In addition, the Client shall act consistently with the Bureau Veritas' Code of Ethics. <https://group.bureauveritas.com/group/corporate-social-responsibility>

Continued from page 1

Part	Volume	Chapter	Section / Appendix
Part D	<i>NR 467 D1 DT R10 E</i>	Ch 6	Sec 2
		Ch 7	Sec 2
		Ch 8	Sec 2, Sec 5, Sec 8, Sec 10, Sec 11, Sec 15
		Ch 9	Sec 5, Sec 11, Sec 16, App 1
		Ch 11	Sec 3
		Ch 13	Sec 2
		Ch 14	Sec 2
Part E	<i>NR 467 E1 DT R01 E</i>	Ch 1	Sec 1, Sec 2, Sec 3
		Ch 7	Sec 1, Sec 2, Sec 4, Sec 7
		Ch 8	Sec 1, Sec 4, Sec 7
Part F	<i>NR 467 F1 DT R10 E</i>	Ch 2	Sec 2
		Ch 3	Sec 1, Sec 4
		Ch 4	Sec 1, Sec 2
		Ch 8	Sec 1, Sec 2, Sec 3
		Ch 9	Sec 1, Sec 2, Sec 3
		Ch 11	Sec 6, Sec 21, Sec 22, Sec 24, Sec 26

Amendments to PART A

Ch 1, Sec 1, [2.2]

Replace requirement [2.2.2] as follows:

2.2.2 If deemed necessary, the Society may require that engineering analysis, assessment and approval of the alternative design and arrangement be carried out in accord-

ance with IMO MSC.1/Circ.1002 as amended, IMO MSC/Circ.1212 as amended and IMO MSC.1/Circ.1455 as amended, as applicable.

Ch 1, Sec 2, Table 1

Replace reference to “NI 589” by “NR 589” in the row “Wind farms service ship”

Ch 1, Sec 2, Table 2

Replace the row “self elevating” by the following one:

Table 2 - List of service notations and additional service features for offshore service vessels

self elevating [4.9.2], [4.9.4] or [4.9.3]	Pt E, Ch 8, Sec 7
--	-------------------

Ch 1, Sec 2, [4.9]

In requirements [4.9.1], [4.9.2], [4.9.3], [4.9.4]: replace the reference to “NR534 Rules for the classification of self-elevating units - jack-ups and liftboats” by the reference to “Pt E, Ch 8, Sec 7”.

Ch 1, Sec 2, [4.10.1]

Replace the third paragraph by:

For ships intended to carry only one type of cargo, the service notation may be completed by an additional service

feature indicating the type of product carried e.g. **barge - oil, barge - general cargo, barge - chemical.**

Ch 1, Sec 2, [4.12.2]

Replace the list as follows:

light ship - fast passenger vessel

light ship - fast cargo vessel

light ship - fast patrol vessel.

Ch 1, Sec 2, [4.16.6]

Replace reference to “Guidance Note NI 589” by “Rule Note NR 589” in the last paragraph.

Part A

Ch 1, Sec 2, [5.2.8]

Add the following bullet at the end of the first bulleted list:

- **wind farm service ship - X0**, as defined in [4.16.6],

Ch 1, Sec 2, [5.3.1]

Replace the fourth paragraph by:

The operating area notation defined in [5.3.4] is, in principle, solely granted to crew boats, wind farms service ships and light ships as defined, respectively, in [4.16.4], [4.16.6] and [4.12.2].

Ch 1, Sec 2, [5.3.4]

Replace the title and the first paragraph by:

5.3.4 Operating area for crew boats, wind farms service ships and light ships

The following operating area notation may be assigned to ships with service notation **crew boat**, **wind farms service ships** or **light ship**:

Ch 1, Sec 2, Table 3

Add the additional class notations “**CYBER MANAGED**”, “**CYBER SECURE**” and “**ULEV**”:

Replace rows “**CLEANSHIP**” and “**DYNAPOS**” by:

Table 3 : List of additional class notations

Additional class notation	Definition in	Reference in NR 467 or to other Rule Notes	Remarks
CYBER MANAGED	[6.14.44]	Rule Note NR 659	
CYBER SECURE (1)	[6.14.44]	Rule Note NR 659	
ULEV	[6.8.15]	Pt F, Ch 11, Sec 26	
CLEANSHIP	[6.8.2]	Part F, Chapter 9	CLEANSHIP and CLEANSHIP SUPER () may be completed by CEMS . between brackets, at least 3 eligible notations are to be assigned among the following ones: AWT-A , AWT-B , AWT-A/B , BWT , EGCS-SCRUBBER , GWT , HVSC , NDO -x days , NOX-x% , OWS-x ppm , SOX-x%
CLEANSHIP SUPER ()	[6.8.3]		
DYNAPOS SAM (1) DYNAPOS AM (1) DYNAPOS AT (1) DYNAPOS AM/AT (1)	[6.14.6]	Pt F, Ch 11, Sec 6	DYNAPOS AM and DYNAPOS AT may be completed by R or RS DYNAPOS AM/AT may be completed by R or RS or (xx ; xx) (corresponding to the two-number vector for the Environmental Station Keeping Index ESKI) DYNAPOS notations may be completed by -HWIL DYNAPOS AM/AT-R or DYNAPOS AM/AT-RS may be completed by -EI DYNAPOS notations may be completed by -ITP

Ch 1, Sec 2, [6.8]

Add the following new requirements [6.8.15] and [6.8.16]:

6.8.15 Ultra-low emission vessel (ULEV)

The additional class notation **ULEV** may be assigned to ships which do not fall into the scope of Regulation (EU) 2016/1628.

The additional class notation **ULEV** is providing the status for internal combustion engines installed on a ship regarding their capacity to emit gaseous pollutants and particular pollutants at a very low level at the moment when they are installed on the ship.

The requirements for the assignment and the maintenance of this notation are given respectively in Pt F, Ch 11, Sec 26 and in Ch 5, Sec 7.

6.8.16 Continuous emission monitoring system (CEMS)

The additional class notations **CLEANSHIP** and **CLEANSHIP SUPER ()** may be completed by the notation **CEMS** when the ship is fitted with a measurement, monitoring, recording and transmission equipment of air emissions in compliance with the requirements laid down in Pt F, Ch 9, Sec 3.

The requirements for the maintenance of this notation are given in Ch 5, Sec 7.

Ch 1, Sec 2, [6.14.6]

Replace the last paragraph by:

The additional class notations **DYNAPOS** may be completed, by the notations **-HWIL** and/or **-ITP** as follows:

- a) The notation **-HWIL** is added to the additional class notation **DYNAPOS** when the control system has been verified according to the requirements of NR632, Hardware-in-the-loop Testing.
- b) The notation **-ITP** is added to the additional class notation **DYNAPOS** when:
 - it has been verified that the testing programme for granting the **DYNAPOS** notation includes the necessary arrangements for incremental testing, and
 - the initial testing trial programme has been validated by the Surveyor, including the proper working of the incremental testing programme.

The notation **-ITP** allows the ship's crew to spread over a period of one year the surveys required for testing all important systems and components to document the ability of a DP vessel to keep position after single failures associated with the assigned equipment class and to validate the FMEA and operation manual, as a part of annual survey as laid down in Ch 5, Sec 10, [5.1.2] and only for this part.

Any test from the approved FMEA test programme not completed by ship's crew at the time of Surveyor's attendance for annual survey has to be carried out before completion of the survey.

The surveys carried out by the ship's crew are to be recorded in the engine, deck and DP logbooks, as applicable, and a survey report is to be prepared for each case tested.

The report is generally to be drawn up in English; however, for ships trading in specific restricted areas the use of the language of the country concerned will be accepted.

The report may be provided in hard copy or using a computerized recording system.

The report, for each item of the approved FMEA test programme, is to indicate the following information:

- identification data:
 - name of ship and register number
 - date and place (port or voyage log) of the test with weather conditions (measured wind speed, estimated wave height,...)
 - numbering of test according to approved FMEA test programme
- test conducted:
 - description, type and result of the test
 - inspection findings if any
- maintenance and repairs carried out and parts replaced, if any.

Supporting documentation such as sketches, photos, measurement reports, are to be attached to the report.

The report is to be signed by both the DP Officer and Chief Engineer.

A confirmatory survey, to be carried out by a Surveyor of the Society, is to be requested, when the ship is within the window for annual survey of its classed DP system.

The Surveyor is to be supplied with a copy of the survey reports and also shown the engine, deck and DP logbooks, as applicable.

The Surveyor carries out the annual survey as laid down in Ch 5, Sec 10, [5.1] and satisfies himself with the validation of the FMEA and operations manual, based on the reports provided by the ship's crew. If doubts arise, the Surveyor extend the tests as deemed necessary.

Part A

Ch 1, Sec 2, [6.14]

Add the following new requirement [6.14.44]:

6.14.44 Cyber security

The additional class notations **CYBER MANAGED** and **CYBER SECURE** may be assigned to ships whose networks comply with the requirements of NR659 Rules on Cyber Security for the Classification of Marine Units.

CYBER MANAGED notation is a first level of Cyber Security. It requires human actions, a strong human organization and a significant amount of procedures to achieve objective.

CYBER SECURE notation is a way to control security by means of automatic softwares. It requires dedicated technical equipment for security.

In compliance with [6.1.3], the additional class notation **CYBER SECURE** is assigned a construction mark, as defined in Article [3].

The requirements for the assignment and the maintenance of these notations are given respectively in NR659 Rules on Cyber Security for the Classification of Marine Units and in Ch 5, Sec 10.

Ch 1, Sec 2, [6.15.2]

Add the following paragraph at the end of the requirement:

The requirements for the maintenance of the notation **IG** are given respectively:

- for **oil tanker** or **FLS tanker**, in Ch 4, Sec 3, [3.4]
- for **chemical tanker** or **supply**, in Ch 4, Sec 4, [3.4].

Ch 2, Sec 2, [2.2]

Add the following new requirement [2.2.20]:

2.2.20 Remote inspection techniques (RIT)

Remote inspection techniques is a means of survey that enables examination of any part of the structure without the need for direct physical access of the Surveyor (refer to IACS Recommendation 42, "Guidelines for use of remote inspection techniques for surveys").

Ch 2, Sec 2, [2.3]

Replace requirement [2.3.3] by:

2.3.3 In any kind of survey, i.e. class renewal, intermediate, annual or other surveys having the same scope, thickness measurements of structures in areas where close-up surveys are required, are to be carried out simultaneously with close-up surveys.

Insert the following new requirements [2.3.4] and [2.3.5]:

2.3.4 Consideration may be given by the attending Surveyor to allow the use of Remote Inspection Techniques (RIT) as an alternative to close-up survey. Surveys conducted using a RIT are to be completed to the satisfaction of the attending Surveyor. When RIT is used for a close-up survey, temporary means of access for the corresponding thickness measurements is to be provided unless such RIT is also able to carry out the required thickness measurements.

Note 1: Use of RIT as an alternative to close-up survey is not allowed for ships assigned with the service notation **bulk carrier**

ESP or bulk carrier BC-A ESP or bulk carrier BC-B ESP or bulk carrier BC-C ESP or self-unloading bulk carrier ESP or ore carrier ESP or combination carrier/OBO ESP or combination carrier/OOC ESP or oil tanker ESP.

2.3.5 For structure built with a material other than steel, alternative thickness measurement requirements may be developed and applied as deemed necessary by the Society.

Ch 2, Sec 2, [2.6]

Add the following new requirement [2.6.3]:

2.6.3 For surveys conducted by use of a remote inspection technique, one or more of the following means of access, acceptable to the Surveyor, is to be provided:

- unmanned robot arm
- remotely operated vehicles (ROV)
- unmanned aerial vehicles/drones

- other means acceptable to the Society.

Note 1: Use of RIT as an alternative to close-up survey is not allowed for ships assigned with the service notation **bulk carrier ESP** or **bulk carrier BC-A ESP** or **bulk carrier BC-B ESP** or **bulk carrier BC-C ESP** or **self-unloading bulk carrier ESP** or **ore carrier ESP** or **combination carrier/OBO ESP** or **combination carrier/OOC ESP** or **oil tanker ESP**.

Ch 2, Sec 2, [2]

Add the following new sub-article [2.12]:

2.12 Remote Inspection Techniques (RIT)

2.12.1 The RIT is to provide the information normally obtained from a close-up survey (except on ESP ships). RIT surveys are to be carried out in accordance with the requirements given here-in and the requirements of IACS Recommendation 42, "Guidelines for use of remote inspection techniques for surveys". These considerations are to be included in the proposals for use of a RIT which are to be submitted in advance of the survey so that satisfactory arrangements can be agreed with the Society.

Note 1: Use of RIT as an alternative to close-up survey is not allowed for ships assigned with the service notation **bulk carrier ESP** or **bulk carrier BC-A ESP** or **bulk carrier BC-B ESP** or **bulk carrier BC-C ESP** or **self-unloading bulk carrier ESP** or **ore carrier ESP** or **combination carrier/OBO ESP** or **combination carrier/OOC ESP** or **oil tanker ESP**.

2.12.2 The equipment and procedure for observing and reporting the survey using a RIT are to be discussed and agreed with the parties involved prior to the RIT survey, and

suitable time is to be allowed to set-up, calibrate and test all equipment beforehand.

2.12.3 When using a RIT as an alternative to close-up survey, if not carried out by the Society itself, it is to be conducted by a firm approved as a service supplier and is to be witnessed by an attending Surveyor of the Society.

Note 1: NR533, Approval of Service Suppliers, gives details about the certification.

2.12.4 The structure to be examined using a RIT is to be sufficiently clean to permit meaningful examination. Visibility is to be sufficient to allow for a meaningful examination. The Society is to be satisfied with the methods of orientation on the structure.

2.12.5 The Surveyor is to be satisfied with the method of data presentation including pictorial representation, and a good two-way communication between the Surveyor and RIT operator is to be provided.

2.12.6 If the RIT reveals damage or deterioration that requires attention, the Surveyor may require traditional survey to be undertaken without the use of a RIT.

Ch 2, Sec 3, [1.3.1]

Replace the last paragraph by:

The class is also withdrawn according to the provisions of article 9 of the Marine & Offshore Division General Conditions in case of contract termination.

Ch 2, App 3, Table 2

Replace the first row by the following one:

Table 2 - List of service notations and additional service features for offshore service vessels

Transverse section of deck plating outside line of cargo hatch openings (for bulk carriers, ore carriers, combination carriers and CSR single skin and double skin bulk carriers).	"Selected" means at least a single point on one out of three plates, to be chosen on representative areas of average corrosion	No figure
--	--	-----------

Replace the ten terminologies "CSR double hull oil tankers" by "CSR oil tankers" in the table.

Ch 2, App 3

Replace the terminology “CSR double hull oil tankers” by “CSR oil tankers” in the titles of Figure 15, Figure 16, Figure 17 and Figure 18.

Ch 2, App 3, Table 5

Replace the row 18 “Transverse bulkheads”, change table foot note (4) and add new table foot note (5) as follows:

Table 5 : Local and global acceptance criteria for general cargo ships (given in % of wastage)

18	Transverse bulkheads (3) (5)				
	plating	30	20	15	–
	stringer web	30	20	–	–
	stringer flange	25	15	–	–
	stiffener web	30	20	–	–
	stiffener flange	25	15	–	–
	brackets	30	20	–	–

(4) For cargo ships constructed (i.e. keel laid) from 1st January 2012:

- steel renewal is required where the gauged thickness is less than $(t_{net} + 0,5)$ mm for:
 - single skin hatch covers
 - plating of double skin hatch covers, and
 - coaming structures the corrosion additions t_c of which are provided in Pt B, Ch 8, Sec 7, Tab 1 (for ships contracted for construction on or after 1st July 2016).
- where the gauged thickness is within the range $(t_{net} + 0,5)$ mm and $(t_{net} + 1,0)$ mm, coating (applied in accordance with the coating manufacturer’s requirements) or annual gauging may be adopted as an alternative to steel renewal. Coating is to be maintained in GOOD condition. If t_{net} is not available, the as-built thickness minus the total corrosion addition can be used.
- for the internal structures of double skin hatch covers, thickness gauging is required when hatch cover top or bottom plating renewal is to be carried out or when this is deemed necessary, at the discretion of the Surveyor, on the basis of the plating corrosion or deformation condition. In these cases, steel renewal for the internal structures is required when the gauged thickness is less than t_{net} . If t_{net} is not available, the as-built thickness minus the total corrosion addition can be used.
- for corrosion addition $t_c = 1,0$ mm the thickness for steel renewal is t_{net} and the thickness for coating or annual gauging is when gauged thickness is between t_{net} and $(t_{net} + 0,5)$ mm.
- for coaming structures, the corrosion addition t_c of which are not provided in Pt B, Ch 8, Sec 7, Tab 1, steel renewal and coating or annual gauging are to be in accordance with the requirements of the Society (for ships contracted for construction on or after 1st July 2016).

For cargo ships constructed (i.e. keel laid) from 1st January 2005:

- for hatch covers in way of cellular cargo holds intended for containers (plating, stiffeners and internals), steel renewal is required where the gauged thickness is less than t_{net} . Where the gauged thickness is within the range t_{net} and $(t_{net} + 0,5)$ mm, coating (applied in accordance with the coating manufacturer’s requirements) or annual gauging may be adopted as an alternative to steel renewal. Coating is to be maintained in good condition. If t_{net} is not available, the as-built thickness minus the total corrosion addition can be used.

(5) For ships indicated in Pt D, Ch 4, Sec 3, [6.1.1], contracted for construction on or after 1 July 2006, vertically corrugated transverse bulkheads are to be repaired by steel renewal where the gauged thickness is less than $(t_{net} + 0,5)$ mm, where t_{net} is the thickness obtained by applying the strength criteria given in Pt D, Ch 4, Sec 3, [6.1]. However, where the gauged thickness is within the range $(t_{net} + 0,5)$ mm and $(t_{net} + 1,0)$ mm, coating (applied in accordance with the coating Manufacturer’s requirements) or annual gauging may be adopted as an alternative to steel renewal.

Ch 2, App 3, [4.8.2]

Replace the first paragraph by:

If pitting intensity, in an area where coating is required according to NR522 CSR for Bulk Carriers, Ch 3, Sec 5, or NR606 CSR for Bulk Carriers and Oil Tankers, Part 1, Ch 3, Sec 4, as applicable, is higher than 15% (see Fig 19), thickness measurements are to be performed to check the extent of pitting corrosion. The 15% is based on pitting or grooving on only one side of a plate. In cases where pitting is exceeding 15%,

as defined above, an area of 300 mm or more, at the most pitted part of the plate, is to be cleaned to bare metal and the thickness is to be measured in way of the five deepest pits within the cleaned area. The least thickness measured in way of any of these pits is to be taken as the thickness to be recorded. The minimum remaining thickness in pits, grooves or other local areas is to be greater than the following values:

Ch 2, App 3, [4.8.3]

Replace the definition of “ t_{ren} ”, “ t_c ” and “ t_m ” by:

- | | | | |
|-----------|--|-------|--|
| t_{ren} | : Renewal thickness, namely minimum allowable thickness, in mm, below which renewal of structural members is to be carried out (see also NR523 CSR for Double Hull Oil Tankers, Section 12 or NR606 CSR for Bulk Carriers and Oil Tankers, Part 1, Chapter 13, as applicable). | t_m | : Measured thickness, in mm, on one item, i.e. average thickness on one item using the various measurements taken on this same item during periodical ship's in service surveys. |
| t_c | : Total corrosion addition, in mm, defined in NR522 CSR for Bulk Carriers, Ch 3, Sec 3 or in NR606 CSR for Bulk Carriers and Oil Tankers, Pt 1, Ch 3, Sec 3, as applicable | | |

Add the following paragraph at the end of the requirement:

The average thickness across any cross-section in the plating is not to be less than the renewal thickness for general corrosion given in NR522 CSR for Bulk Carriers, Chapter 13

or in NR523 CSR for Double Hull Oil Tankers, Section 12 or in NR606 CSR for Bulk Carriers and Oil Tankers, Part 1, Chapter 13, as applicable.

Ch 2, App 3, [4.8.4]

Replace the second and third paragraph as follows:

The average measured thickness t_m across the breadth or height of the stiffener is not to be less than the one defined in NR522 CSR for Bulk Carriers, Chapter 13 or in NR523 CSR for Double Hull Oil Tankers, Section 12 or in NR606 CSR for Bulk Carriers and Oil Tankers, Part 1, Chapter 13, as applicable.

Plate edges at openings for manholes, lightening holes, etc... may be below the minimum thickness given in NR522 CSR for Bulk Carriers, Chapter 13 or in NR523 CSR for Double Hull Oil Tankers, Section 12, or in NR606 CSR for

Bulk Carriers and Oil Tankers, Part 1, Chapter 13, as applicable, provided that:

- a) The maximum extent of the reduced plate thickness, below the minimum given in NR522 CSR for Bulk Carriers, Chapter 13 or in NR523 CSR for Double Hull Oil Tankers, Section 12 or in NR606 CSR for Bulk Carriers and Oil Tankers, Part 1, Chapter 13, as applicable, from the opening edge is not more than 20% of the smallest dimension of the opening and does not exceed 100 mm.

Ch 2, App 3, [4.8.5]

Replace item b) as follows:

- b) Structural members with areas of grooving greater than those in item a) are to be assessed, based on the criteria for general corrosion as defined in NR522 CSR for Bulk Carriers, Chapter 13 or in NR523 CSR for Double Hull

Oil Tankers, Section 12 or in NR606 CSR for Bulk Carriers and Oil Tankers, Part 1, Chapter 13, as applicable, using the average measured thickness across the plating/stiffener.

Ch 3, Sec 1, [2.1.1]

Add the following new bullet at the end of the bulleted list:

- for ships fitted with independent cargo tanks, confirmation that cargo piping and tanks are electrically bonded to the hull, as applicable.

Ch 3, Sec 2, [2.1]

Add the following new requirement [2.1.2]:

2.1.2 For ships fitted with independent cargo tanks, external examination of cargo tanks, as far as practicable, including tank supports, chocks and keys. The internal examination may be required if deemed necessary by the Surveyor.

For ships fitted with independent cargo tanks, confirmation that cargo piping and tanks are electrically bonded to the hull, as applicable.

Part A

Ch 3, Sec 3, [2.2.3]

Replace the first bullet of the bulleted list by:

- windlass and chain stoppers, with disassembly as deemed necessary to verify the condition of the equipment and control and safety devices, holdfasts, hawse pipes

Ch 3, Sec 3, [2.3.1]

Add the following paragraph at the end of the requirement:

At class renewal survey No.3 and subsequent class renewal surveys, structural down flooding ducts and structural ventilation ducts are to be internally examined.

Ch 3, Sec 3, [2]

Add the following new sub-article [2.6]:

2.6 Independent cargo tanks

2.6.1 All independent cargo tanks are to be cleaned and examined internally, as well as their liquid-level indicators.

2.6.2 When accessible, the outer surface of uninsulated cargo tanks or the outer surface of cargo tank insulation is to be examined.

Special attention is to be given to the tank and insulation in way of chocks, supports, keys, anti-rolling/pitching systems.

Removal of insulation, in part or entirely, may be required in order to verify the condition of the tank or the insulation itself if deemed necessary by the Surveyor.

2.6.3 Thickness measurements may be required if deemed necessary by the Surveyor.

2.6.4 The tightness of all cargo tanks is to be verified by an appropriate procedure.

2.6.5 The pressure relief valves for the cargo tanks are to be opened for examination, adjusted, function tested and sealed. Where a proper record of continuous overhaul and re-testing of individually identifiable relief valves is maintained, consideration may be given to acceptance on the basis of opening, internal examination and testing of a representative sample of valves, including each size and type

of relief valves in use, provided there is evidence in the log-book that the remaining valves have been overhauled and tested since crediting of the previous class renewal survey.

2.6.6 The cargo containment venting system is to be examined.

2.6.7 All piping, equipment and machinery for loading, venting, heating or otherwise handling the cargo are to be examined. Insulation is to be removed as deemed necessary to ascertain the condition of the pipes.

If the visual examination raises doubts as to the integrity of the pipelines, a pressure test at 1,25 times the MARVS for the pipeline is to be carried out. After reassembly the complete piping systems are to be tested for leaks.

2.6.8 All emergency shutdown and quick-closing valves in the cargo piping systems are to be examined and proven operable. A random selection of valves is to be opened up for examination.

2.6.9 Holds around cargo tanks are to be internally examined. In case of ships built without longitudinal bulkhead in the centre line of the ship, and fitted with long deck beams, the welded connections between the deck beams and the plating of the double hull spaces are to be thoroughly examined.

Ch 3, Sec 4, [3.1]

Replace requirements [3.1.3] and [3.1.4] by:

3.1.3 Proposals for in-water survey are to be submitted in advance of the survey by the Owner so that satisfactory arrangements can be agreed with the Society.

The in-water survey is to be carried out with the ship in sheltered water and preferably with weak tidal streams and currents. The in-water visibility and the cleanliness of the hull below the waterline are to be clear enough to permit a meaningful examination allowing the Surveyor and the in-

water survey firm to determine the condition of the plating, the appendages and the welding.

The equipment, procedure for observing and reporting the survey are to be discussed with the parties involved prior to the in-water survey, and suitable time is to be allowed to permit the in-water survey firm to test all equipment beforehand.

3.1.4 The in-water survey is to be carried out under the surveillance of a Surveyor by an in-water survey firm approved as a service supplier by the Society according to Ch 2, Sec 2, [2.4].

The Surveyor is to be satisfied with the methods of orientation of the diver(s) or remotely operated vehicle (ROV) on

the plating, which should make use where necessary of permanent markings on the plating at selected points and with the method of pictorial representation. An efficient two-way communication between the Surveyor and the diver(s) is to be provided.

Ch 4, Sec 2, [1.1.6]

Replace the second bullet of the bulleted list by:

- the thickness measurement firm is to be part of the survey planning meeting to be held prior to commencing the survey.

Ch 4, Sec 2, [1.3]

Replace requirement [1.3.2] by:

1.3.2 For CSR bulk carriers, the ship longitudinal strength is to be evaluated, using thickness of the structural members measured, renewed and reinforced, as appropriate, during the renewal surveys carried out after the ship reached 15 years of age (or during the 3rd renewal survey, if this one

is carried out before the ship reaches 15 years), in accordance with the criteria for longitudinal strength of the ship hull girder for CSR bulk carriers specified in NR522 CSR for Bulk Carriers, Chapter 13 or in NR606 CSR for Bulk Carriers and Oil Tankers, Part 1, Chapter 13, as applicable.

Ch 4, Sec 2, [1.5.4]

Replace item b) by the following 2 items b) and c):

b) Subsequent intermediate surveys and class renewal surveys:

- either permanent or temporary staging and passages through structures for close-up survey of at least the upper part of hold frames
- hydraulic arm vehicles such as conventional cherry pickers for surveys of lower and middle part of shell frames as alternative to staging
- lifts and movable platforms
- boats or rafts provided the structural capacity of the hold is sufficient to withstand static loads at all levels of water
- other equivalent means.

c) Notwithstanding the above requirements:

- 1) The use of a portable ladder fitted with a mechanical device to secure the upper end of the ladder is acceptable for the:
 - close-up survey of sufficient extent, minimum 25% of frames, to establish the condition of the lower region of the shell frames including

approximately the lower one third length of side frame at side shell and side frame end attachment and the adjacent shell plating in the forward cargo hold at annual survey of cargo holds for single skin bulk carriers between 10 and 15 years

- close-up survey of sufficient extent, minimum 25% of frames, to establish the condition of the lower region of the shell frames including approximately the lower one third length of side frame at side shell and side frame end attachment and the adjacent shell plating in the forward cargo hold and one other selected cargo hold at annual survey of cargo holds for single skin bulk carriers over 15 years.
- 2) The use of hydraulic arm vehicles or aerial lifts ("Cherry picker") may be accepted by the attending surveyor for the close-up survey of the upper part of side shell frames or other structures in all cases where the maximum working height is not more than 17 m.

Part A

Ch 4, Sec 2, [2]

Insert the following new sub-article [2.1]:

2.1 General

2.1.1 The survey is to consist of an examination for the purpose of ensuring, as far as practicable, that the hull and piping are maintained in a satisfactory condition and should

take into account the service history, condition and extent of the corrosion prevention system of ballast tanks and areas identified in the survey report file.

Ch 4, Sec 2, [2.1.4]

Add the following paragraph at the end of the existing requirement [2.1.4]:

Where hatch covers or coamings undergo substantial repairs, the strength of securing devices should be upgraded to comply with the requirements laid down in Ch 6, App 1, [6.2], [6.3] and [6.4].

Ch 4, Sec 2, [2.1.6]

Replace the existing requirement [2.1.6] by:

2.1.6 At each hatchway, the coamings, with plating stiffeners and brackets, are to be checked for corrosion, cracks and deformation, especially of the coaming tops, including close-up survey.

Ch 4, Sec 2, [2.1.9]

Add the following bullet at the end of the bulleted list, in the existing requirement [2.1.9]:

- examination of watertight penetrations as far as practicable.

Ch 4, Sec 2, [4.2]

Replace requirement [4.2.2] by:

4.2.2 Prior to commencement of any part of the renewal and intermediate survey, a survey planning meeting is to be held between the attending surveyor(s), the owner's representative in attendance, the thickness measurement firm representative, where involved, and the master of the ship

or an appropriately qualified representative appointed by the master or Company for the purpose to ascertain that all the arrangements envisaged in the survey programme are in place, so as to ensure the safe and efficient conduct of the survey work to be carried out. See also Ch 2, Sec 2, [2.3.2].

Ch 4, Sec 2, [4.2.3]

Replace item i) as follows:

- communication between attending surveyor(s), the thickness measurement firm operator(s) and owner representative(s) concerning findings.

Ch 4, Sec 2

Replace Figure 1 and change the title as follows:

Figure 1 : Close-up surveys and thickness measurement areas for single skin bulk carriers

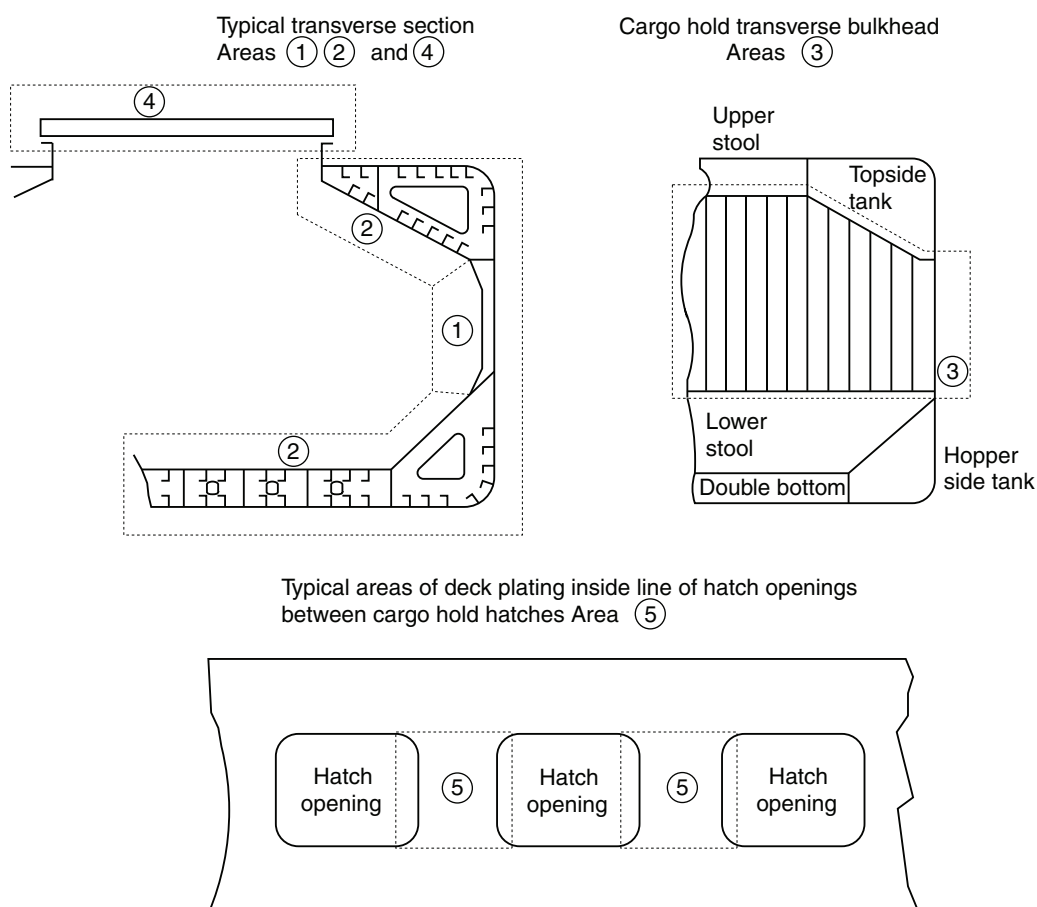

Ch 4, Sec 3, [1.1.7]

Replace the second bullet of the bulleted list by:

- the thickness measurement firm is to be part of the survey planning meeting to be held prior to commencing the survey.

Ch 4, Sec 3, [2]

Insert the following new sub-article [2.1]:

2.1 General

2.1.1 The survey is to consist of an examination for the purpose of ensuring, as far as practicable, that the hull and piping are maintained in a satisfactory condition and should

take into account the service history, condition and extent of the corrosion prevention system of ballast tanks and areas identified in the survey report file.

Ch 4, Sec 3, [2.1.1]

Add the following bullet at the end of the bulleted list, in the existing requirement [2.1.1]:

- examination of watertight penetrations as far as practicable.

Part A

Ch 4, Sec 3, [6.1.3]

Replace item k) as follows:

- k) identification of the thickness measurement firm

Ch 4, Sec 3, [6.2]

Replace requirement [6.2.2] by:

6.2.2 Prior to commencement of any part of the renewal and intermediate survey, a survey planning meeting is to be held between the attending surveyor(s), the owner's representative in attendance, the thickness measurement firm operator (as applicable) and the master of the ship or an

appropriately qualified representative appointed by the master or Company for the purpose to ascertain that all the arrangements envisaged in the survey programme are in place, so as to ensure the safe and efficient conduct of the survey work to be carried out. See also [1.1.7].

Ch 4, Sec 3, [6.2.3]

Replace item i) as follows:

- i) communication between attending surveyor(s), the thickness measurement firm operator(s) and owner representative(s) concerning findings.

Ch 4, Sec 3, Table 2

Replace table foot note (1) by:

(1) Ballast tank: apart from the fore and aft peak tanks, the term "ballast tank" has the following meaning:

- all ballast compartments (hopper tank, side tank and double-deck tank, if separate from double-bottom tank) located on one side, i.e. portside or starboard side, and additionally double-bottom tank on portside plus starboard side, when the longitudinal central girder is not watertight and, therefore, the double-bottom tank is a unique compartment from portside to starboard side; or
- all ballast compartments (double-bottom tank, hopper tank, side tank and double-deck tank) located on one side, i.e. portside or starboard side, when the longitudinal central girder is watertight and, therefore, the portside double-bottom tank separate from the starboard side double-bottom tank.

Ch 4, Sec 4, [1.1]

Insert the following new requirement [1.1.5]:

1.1.5 Consideration may be given by the attending Surveyor to allow use of remote inspection techniques (RIT) as an alternative to close-up survey, as defined in Ch 2, Sec 2.

Surveys conducted using a RIT are to be completed to the satisfaction of the attending Surveyor.

Replace the second bullet of the bulleted list, in the existing requirement [1.1.6] by:

- the thickness measurement firm is to be part of the survey planning meeting to be held prior to commencing the survey.

Ch 4, Sec 4, [1.5]

Add the following new requirement [1.5.3]:

1.5.3 For surveys conducted by use of remote inspection technique, one or more of the following means for access, acceptable to the Surveyor, is to be provided:

- unmanned robot arm

- remote operated vehicle (ROV)
- unmanned aerial vehicles/drones
- other means acceptable to the Society.

Ch 4, Sec 4, [2]

Insert the following new sub-article [2.1]:

2.1 General

2.1.1 The survey is to consist of an examination for the purpose of ensuring, as far as practicable, that the hull and piping are maintained in a satisfactory condition and should

take into account the service history, condition and extent of the corrosion prevention system of ballast tanks and areas identified in the survey report file.

Ch 4, Sec 4, [2.1.1]

Add the following bullet at the end of the bulleted list, in the existing requirement [2.1.1]:

- examination of watertight penetrations as far as practicable.

Ch 4, Sec 4, [6.1.3]

Replace item k) as follows:

- k) identification of the thickness measurement firm

Ch 4, Sec 4, [6.2]

Replace requirement [6.2.2] by:

6.2.2 Prior to commencement of any part of the renewal and intermediate survey, a survey planning meeting is to be held between the attending surveyor(s), the owner's representative in attendance, the thickness measurement firm representative, where involved, and the master of the ship

or an appropriately qualified representative appointed by the master or Company for the purpose to ascertain that all the arrangements envisaged in the survey programme are in place, so as to ensure the safe and efficient conduct of the survey work to be carried out. See also Ch 2, Sec 2, [2.3.2].

Ch 4, Sec 4, [6.2.3]

Replace the last bullet of the bulleted list by:

- communication between attending surveyor(s), the thickness measurement firm operator(s) and owner representative(s) concerning findings.

Ch 4, Sec 5, [1.1]

Add the following new requirement [1.1.5]:

1.1.5 Consideration may be given by the attending Surveyor to allow use of remote inspection techniques (RIT) as an alternative to close-up survey, as defined in Ch 2, Sec 2. Surveys conducted using a RIT are to be completed to the satisfaction of the attending Surveyor.

When RIT is used for a close-up survey, temporary means of access for the corresponding thickness measurements as specified in this section is to be provided unless such RIT is also able to carry out the required thickness measurements.

For surveys conducted by use of a remote inspection technique, one or more of the following means of access, acceptable to the Surveyor, is to be provided:

- unmanned robot arm
- remote operated vehicle (ROV)
- unmanned aerial vehicles/drones
- other means acceptable to the Society.

Part A

Ch 4, Sec 5, [6.2]

Replace requirements [6.2.1] and [6.2.2] by:

6.2.1 A specific survey programme is recommended to be worked out in advance of the class renewal survey by the Owner in cooperation with the Society.

6.2.2 The survey programme is recommended to include conditions for survey, access to structures and equipment for surveys, taking into account the minimum requirements of Tab 2 and Tab 3 for close-up survey and thickness measurements, and [6.6] for tank testing.

Ch 4, Sec 7, [1.1]

Add the following paragraph at the end of the requirement [1.1.1]:

In case of ships with hybrid cargo hold arrangements, e.g. with some cargo holds of single-side skin and others of double-side skin, the requirements of this Section are to be applied only to the structure in way of the single-side skin cargo hold region.

Add the following new requirement [1.1.5]:

1.1.5 Consideration may be given by the attending Surveyor to allow use of remote inspection techniques (RIT) as an alternative to close-up survey, as defined in Ch 2, Sec 2. Surveys conducted using a RIT are to be completed to the satisfaction of the attending Surveyor.

When RIT is used for a close-up survey, temporary means of access for the corresponding thickness measurements as specified in this section is to be provided unless such RIT is also able to carry out the required thickness measurements.

For surveys conducted by use of a remote inspection technique, one or more of the following means of access, acceptable to the Surveyor, is to be provided:

- unmanned robot arm
- remote operated vehicle (ROV)
- unmanned aerial vehicles/drones
- other means acceptable to the Society.

Ch 4, Sec 9, [5.4.2]

Replace the first bullet of the bulleted list by:

- opening for examination, adjustment and function test of pressure relief valves for the fuel supply and bunkering piping

Ch 5, Sec 1, Table 1

Add in the row "Pollution prevention" the additional class notations "ULEV" and "CEMS".

Add in the last row "Other notations" the additional class notations "CYBER MANAGED" and "CYBER SECURE".

Ch 5, Sec 7, [1.1.1]

Add the following two items in the bulleted list:

- CEMS
- ULEV

Ch 5, Sec 7, [2.2.2]

Replace the 2nd bullet of the bulleted list by:

- garbage record book (for **CLEANSHIP** and **CLEANSHIP SUPER**)

Ch 5, Sec 7, [3]

Add the following new sub-articles [3.3] and [3.4]

3.3 Ultra-low emission vessel (ULEV)

3.3.1 At each annual, intermediate and class renewal survey, the following is to be checked:

- proper operation of the NO_x Control Diagnostic (NCD) and Particulate Control Diagnostic (PCD) systems
- proper operation of the recording of the status of the engines related to the operations in the **ULEV** mode
- validity of the list of engines able to fulfil the **ULEV** additional is to be checked with manufacturer justification in case of replacement or modification of engines.

3.4 Continuous emission monitoring system (CEMS)

3.4.1 At each annual, intermediate and class renewal survey, the following is to be checked:

- confirmation that the waste discharge and air emission parameters required to be monitored and recorded are transmitted on a regular basis via a satellite communication system to a shipowner facility ashore
- confirmation that such information is made available to the Surveyor upon request.

Ch 5, Sec 10, [1.1.1]

Add the following two items in the list:

CYBER MANAGED

CYBER SECURE

Ch 5, Sec 10, [5.1.2]

Replace the 7th bullet of the bulleted list by:

- test of all important systems and components to document the ability of the DP vessel to keep position after single failures associated with the assigned equipment class and to validate the FMEA and operations manual
Note 1: for ships granted with the - **ITP notation**, reference is made to Ch 1, Sec 2, [6.14.6].

Ch 5, Sec 10, [18.3]

Add the following new requirement [18.3.4]:

18.3.4 In addition to the requirements of [18.3.1], for **PB** and **ZE** modes, the survey is to include:

- ESS charging test, with evaluation of charging current and time for complete charging of the batteries (to reach full charge, just after a full discharge, in the conditions defined by the load balance).

Ch 5, Sec 10

Add the following new Article [19]:

19 CYBER MANAGED and CYBER SECURE

19.1 General

19.1.1 The requirements of this Article apply to ships which have been assigned one of the following additional class notations related to cyber security as described in Ch 1, Sec 2, [6.14.44]:

- **CYBER MANAGED**
- **CYBER SECURE**

The surveys are to be systematically recorded in the cyber registry: date, actors, tests performed, results and conclusions.

19.2 Annual surveys

19.2.1 Documents to be updated

Regarding Level 3 equipment only, the following documents are to be updated:

- Cyber Risk Analysis.

19.2.2 Documents to be submitted

The following documents are to be submitted:

- Cyber Registry
- Cyber Repository, if modified
- Cyber Handbook, if modified
- Cyber Survey manual, if modified.

19.2.3 Surveys

The Surveyor verifies that test reports submitted by the Cyber Security Responsible are consistent with the approved Cyber Survey Manual.

19.3 Intermediate surveys

19.3.1 Documents to be updated

Regarding Level 3 equipment only, the following documents are to be updated:

- Cyber Risk Analysis
- Cyber Repository (system identification part).

19.3.2 Documents to be submitted

The following documents are to be submitted:

- Cyber Registry
- Cyber Handbook, if modified
- Cyber Survey Manual, if modified.

19.3.3 Surveys

The Surveyor verifies that test reports submitted by the Cyber Security Responsible are consistent with the approved Cyber Survey Manual.

19.4 Class renewal surveys

19.4.1 Documents to be updated

The following documents are to be updated:

- Cyber Risk Analysis.

Regarding Level 2 and Level 3 equipments only, the following documents are to be updated:

- Cyber Repository (system identification part).

19.4.2 Documents to be submitted

The following documents are to be submitted:

- Cyber Registry
- Cyber Handbook, if modified
- Cyber Survey Manual, if modified.

19.4.3 Surveys

The Surveyor verifies that test reports submitted by the Cyber Security Responsible are consistent with the approved Cyber Survey Manual.

Amendments to PART B

Ch 2, Sec 3, [4.1]

Replace requirement [4.1.2] by:

4.1.2 Access to the tunnel is to be provided by a water-tight door fitted on the aft bulkhead of the engine room in compliance with Ch 2, Sec 1, [6].

Ch 4, Sec 3, [1.1.5]

Add the following paragraph at the end of the requirement:

Generally, the radius of openings corners is to be not less than 50 mm. In way of highly stressed areas, the radius is to be taken as the greater of 50 mm and 8% of the opening width.

Ch 4, Sec 6, [1.2.4]

Replace the first bullet of the bulleted list by:

- stepped or knuckled strength decks

Ch 4, Sec 6, [4.1.4]

Replace reference to “Ch 4, Sec 4, [4]” by “Ch 4, Sec 7, [1.2.8]”.

Ch 4, Sec 6, [4.2]

Replace requirement [4.2.1] by:

4.2.1 Heads and heels of pillars are to be attached to the surrounding structure by means of brackets or insert plates so that the loads are well distributed.

Insert plates may be replaced by doubling plates, except in the case of pillars which may also work under tension such

as those in tanks. In such case, the doubling plates are to comply with the requirements in Ch 4, Sec 1, [2.7] in order to prevent laminar tearing.

In general, the net thickness of doubling plates is to be not less than 1,5 times the net thickness of the pillar.

Ch 4, Sec 7, [1.2]

Add the following new requirement [1.2.8]:

1.2.8 Bulkheads acting as pillars

Each vertical stiffener is to comply with the applicable buckling requirement in Ch 7, Sec 2, [4] considering:

- a width of associated plating equal to 35 times the plating net thickness
- a supported load determined according to the require-

ments for pillars in Ch 7, Sec 3, [7.2.1]

- a resistance partial safety factor, γ_{Rv} , equal to 1,15 for column buckling and 1,05 for torsional and local buckling.

Part B

Ch 4, Sec 7

Delete Article [4]

Ch 7, Sec 3, [4.4.4]

Replace the second bullet of the bulleted list by:

- for fine mesh along rounded edges (openings, rounded brackets) the area considered for stress averaging is to be limited only to the first ring of border elements, over

a length not greater than the lesser between 1.5 times the radius of the opening and the relevant spacing of ordinary stiffeners (see Fig 4 and Fig 5)

Ch 8, Sec 2, [4.1.2]

Replace “ h_{SI} ” by “ h_{SL} ” in the second paragraph.

Ch 8, Sec 2, [4.2.1]

Replace the definition of “ h_{SL} ” by:

h_{SL} : Maximum relative wave elevation, in m, to be taken as follows:

$$h_{SL} = 11,65 H C_{B-LC}^{2,5} C_{W-LC}^{-4,9}$$

with:

C_{B-LC} : Block coefficient at considered loading condition draught T_1

C_{W-LC} : Waterplane coefficient at considered loading condition draught T_1

Ch 8, Sec 4, [1.1]

Replace requirement [1.1.1] by:

1.1.1 The requirements of this Section apply for the scantling of plating and associated structures of front, side and aft bulkheads and decks of superstructures and deckhouses.

Ch 8, Sec 4, [1.3]

Replace requirement [1.3.1] by the following new requirements [1.3.1 and [1.3.2]:

1.3.1 Superstructures

Superstructures are defined in Pt B, Ch 1, Sec 2, [3.13].

1.3.2 Deckhouses

Deckhouses are defined in Pt B, Ch 1, Sec 2, [3.16].

Ch 8, Sec 4, [2]

Replace the title of sub-article [2.1] by:

2.1 Side bulkheads of superstructures

Replace the title of sub-article [2.2] by:

2.2 Side and end bulkheads of deckhouses and end bulkheads of superstructures

Ch 8, Sec 4, [2.2.2]

Replace the first paragraph by:

The lateral pressure to be used for the determination of scantlings of front, side and aft bulkheads of deckhouses and of front and aft bulkheads of superstructures is to be obtained, in kN/m², from the following formula:

Ch 8, Sec 4, Table 1

Add table foot note (1) at the end of the Table 1 and modify the row "Side" as follows:

Table 1 : Lateral pressure for superstructures and deckhouses - Coefficient a

Side (1)	Lowest, second and third tiers	$0,5 + \frac{L}{150}$	2,5
	Fourth tier	$0,9 \left(0,5 + \frac{L}{150} \right)$	2,25
	Fifth tier and above	$0,8 \left(0,5 + \frac{L}{150} \right)$	2,0
(1) Applicable only to side bulkheads of deckhouses			

Ch 8, Sec 4, [2.3.1]

Replace the first paragraph by:

2.3.1 The lateral pressure for the determination of deck scantlings is constituted by the still water internal pressure (p_s) and the inertial pressure (p_w), defined in Ch 5, Sec 6, [4].

Ch 8, Sec 4, [3.1]

Replace requirement [3.1.1] by:

3.1.1 Plating of side bulkheads of superstructures

The net thickness of plating of side bulkheads of superstructures is to be determined in accordance with the applicable requirements of Ch 7, Sec 1, considering the lateral pressure defined in [2.1.2].

Replace title and first paragraph of requirement [3.1.2] by:

3.1.2 Plating of side and end bulkheads of deckhouses and of end bulkheads of superstructures

The net thickness of plating of side and end bulkheads of deckhouses and of end bulkheads of superstructures is to be not less than the value obtained, in mm, from the following formula:

Part B

Ch 8, Sec 4, [3.2]

Replace requirement [3.2.1] by:

3.2.1 The net thickness of deck plating is to be determined in accordance with the applicable requirements of Ch 7, Sec 1.

Ch 8, Sec 4, [4.1.1]

Replace the first bullet of the bulleted list by:

- [4.1.2] for single span vertical ordinary stiffeners of deckhouses side and end bulkheads and of superstructures end bulkheads.

Ch 8, Sec 4, [4.1.2]

Replace title and first paragraph by:

4.1.2 Ordinary stiffeners of side and end bulkheads of deckhouses and of end bulkheads of superstructures

The net section modulus of ordinary stiffeners of side and end bulkheads of deckhouses and of end bulkheads of superstructures is to be not less than the value obtained, in cm³, from the following formula:

Ch 8, Sec 4, [4.2]

Replace requirement [4.2.1] by:

4.2.1 The net scantlings of deck ordinary stiffeners are to be determined in accordance with the applicable requirements of Ch 7, Sec 2.

Ch 8, Sec 4, [5.1]

Replace requirements [5.1.1] and [5.1.2] by:

5.1.1 Primary supporting members of side bulkheads of superstructures

The net scantlings of primary supporting members of side bulkheads of superstructures are to be determined in accordance with the applicable requirements of Ch 7, Sec 3.

5.1.2 Primary supporting members of side and end bulkheads of deckhouses and of end bulkheads of superstructures

The net scantlings of primary supporting members of side and end bulkheads of deckhouses and of end bulkheads of superstructures are to be determined in accordance with the applicable requirements of Ch 7, Sec 3, using the lateral pressure defined in [2.2].

Ch 8, Sec 4, [5.2]

Replace requirement [5.2.1] by:

5.2.1 The net scantlings of deck primary supporting members are to be determined in accordance with the applicable requirements of Ch 7, Sec 3.

Ch 8, Sec 10, [3]

Replace sub-article [3.3] by:

3.3 Glasses

3.3.1 General

In general, toughened glasses with frames of special type are to be used in compliance with, or equivalent to, recognised national or international standards.

Direct metal to glass contact is to be avoided.

The use of clear plate glasses is considered by the Society on a case by case basis.

3.3.2 Design loads

The design load is to be determined in accordance with the applicable requirements of Ch 8, Sec 4, [2].

In damaged ship conditions, where windows or sidescuttles are located below the deepest equilibrium waterline, the design pressure p , in kN/m^2 , is to be taken equal to:

$$p = p_s + p_w$$

where:

p_s : Still water pressure, taken equal to:

$$p_s = \rho g d_f$$

p_w : Wave pressure, taken equal to:

$$p_w = 0,6 \rho g h_1 e^{\frac{-2\pi(d_f)}{L}}$$

d_f : Distance, in m, from the calculation point to the deepest equilibrium waterline.

The deepest equilibrium waterlines are to be provided by the Designer under his own responsibility.

h_1 : Reference values of the ship relative motions in the upright ship condition, defined in Ch 5, Sec 3, [3.3]

3.3.3 Scantling

The windows and sidescuttles assessment methodology defined in this Article is equivalent to Standard ISO 11336-1:2012.

The scantling of windows and sidescuttle defined in this sub-article are provided for the following types of window or sidescuttle:

- monolithic window or sidescuttle (see [3.3.4])
- laminated window or sidescuttle (see [3.3.5])
- double windows unit with gap (see [3.3.9]).

All the window and sidescuttle edges are considered as simply supported.

3.3.4 Thickness of monolithic window

The thicknesses, in mm, of monolithic windows and sidescuttles are to be obtained from the following formula:

- rectangular window or sidescuttle:

$$t = 31,6s \sqrt{\frac{\beta p S_f}{R_m}}$$

- circular window or sidescuttle:

$$t = 17,4d \sqrt{\frac{\beta p S_f}{R_m}}$$

where:

s : Shorter side, in m, of rectangular window or sidescuttle

Where the window is supported only on 2 edges, s is to be taken as the unsupported side

ℓ : Longer side, in m, of rectangular window or sidescuttle

d : Diameter, in m, of circular window or sidescuttle

R_m : Guaranteed minimum flexural strength, in N/mm^2 , of material used. For guidance only, the guaranteed minimum flexural strength R_m for glass window is:

- for thermally or chemically toughened glass:
 $R_m = 160 \text{ N/mm}^2$
- for polymethylmethacrylate (PMMA) glass:
 $R_m = 100 \text{ N/mm}^2$
- for polycarbonate (PC) glass:
 $R_m = 90 \text{ N/mm}^2$

S_f : Safety factor taken equal to:

- 4,0 for thermally or chemically toughened glass:
- 3,5 for polymethylmethacrylate (PMMA) or polycarbonate (PC) glass:

β : Aspect ratio coefficient of the rectangular window or sidescuttle, obtained in Tab 1

Where the window is supported only by 2 edges, β is to be taken equal to 1,0.

The thickness of windows or sidescuttles having other shapes may be obtained by considering rectangles or circles of equivalent dimensions s_{eq} , ℓ_{eq} or d_{eq} as defined in Tab A.

Table 1 : Coefficient β

ℓ/s	β
1,0	0,284
1,5	0,475
2,0	0,608
2,5	0,684
3,0	0,716
3,5	0,734
$\geq 4,0$	0,750

3.3.5 Laminated window

Laminated windows are windows realized by placing an interlayer of resin (polyvinyl butyral as a general rule) between plies of same or different materials.

For laminated windows made with plies of the same material:

- When the mechanical properties of the interlayer material (the laminating adhesive material) are not known, the plies of the laminated window are considered as mechanically independent, and the equivalent thickness is to be calculated as defined in [3.3.6].

Part B

- When the mechanical properties of the interlayer material are known in terms of shear modulus, G , in N/mm^2 , the plies of the laminated window are considered as mechanically collaborating, and the equivalent thickness is to be calculated as defined in [3.3.7].

When the laminated window is made with plies of different materials, they are considered as mechanically independent, and the equivalent thickness is to be calculated as defined in [3.3.8].

3.3.6 Thickness of laminated window with independent plies

The equivalent thickness t_{eq} , in mm, of laminates made of n independent plies of thicknesses $t_{p,1}, t_{p,2}, \dots, t_{p,n}$, is to comply with the following formula:

$$t_{eq} \geq t$$

where:

$$t_{eq} = \min[t_{eq,j}]$$

$$t_{eq,j} = \sqrt[n]{\frac{\sum_{j=1}^n t_{p,j}^3}{t_{p,j}}}$$

j : Ply index, ranging from 1 to n

t : Thickness, in mm, of a monolithic window, calculated according to [3.3.4].

3.3.7 Thickness of laminated window with collaborating plies

The equivalent thickness t_{eq} , in mm, of laminates made of two collaborating plies of the same material, and of thicknesses t_1 and t_2 separated by an interlayer of thickness t_i is to comply with the following formula:

$$t_{eq} \geq t$$

where:

$$t_{eq} = \min[t_{1eq,s}, t_{2eq,s}]$$

$t_{1eq,s}, t_{2eq,s}$: Equivalent thickness for strength as obtained from the following formulae:

$$t_{1eq,s} = \sqrt{\frac{t_{eq,d}^3}{t_1 + 2\Gamma t_{s2}}}$$

$$t_{2eq,s} = \sqrt{\frac{t_{eq,d}^3}{t_2 + 2\Gamma t_{s1}}}$$

$t_{eq,d}$: Equivalent thickness for deflection as obtained from the following formula:

$$t_{1eq,d} = \sqrt[3]{t_1^3 + t_2^3 + 12\Gamma I_s}$$

Γ : Shear transfer coefficient as obtained from the following formula, without being taken less than 0 (independent plies behaviour) and more than 1,0 (monolithic behaviour):

$$\Gamma = \frac{31,62}{1 + 9,6 \frac{E I_s t_i}{G h s^2 s^2}}$$

$$t_{s1} = \frac{h s \cdot t_1}{t_1 + t_2}$$

$$t_{s2} = \frac{h s \cdot t_2}{t_1 + t_2}$$

$$I_s = t_1 t_{s2}^2 + t_2 t_{s1}^2$$

$$h s = 0,5(t_1 + t_2) + t_i$$

G : Shear modulus of the interlayer at 25 °C, in N/mm^2 , generally taken equal to 1,6 N/mm^2 for polyvinyl butyral (PVB).

For other interlayer materials the shear modulus value at 25 °C for short time duration load (60 s) shall be declared by the interlayer material manufacturer

E : Young's modulus of the plies, in N/mm^2

s : Shorter side, in m, of rectangular window or sidescuttle.

In case of multiple (more than two plies) laminates the calculation is to be iterated. The iteration is to start from the outer ply (the one directly loaded by water pressure) and end with the inner ply.

3.3.8 Thickness of laminated window with plies of different materials

The equivalent thickness t_{eq} , in mm, of laminates made of n plies of different materials, of thicknesses $t_{p,1}, t_{p,2}, \dots, t_{p,n}$ and of Young's modulus $E_{p,1}, E_{p,2}, \dots, E_{p,n}$ is to comply with the following formula:

$$t_{eq} \geq t$$

where:

$$t_{eq} = \min[t_{eq,j}]$$

$$t_{eq,j} = \sqrt[n]{\frac{\sum_{j=1}^n E_{p,j} t_{p,j}^3}{t_{p,j}}}$$

j : Ply index, ranging from 1 to n

t : Thickness, in mm, of a monolithic window, calculated according to [3.3.4] for the same material than the ply giving the minimum value of $t_{eq,j}$.

3.3.9 Thickness of double windows

Double windows are glass windows made of two plies of glass separated by an hermetically sealed spacebar.

The thickness of the ply exposed to the loads defined in [3.3.2] is to be calculated as per monolithic windows according to [3.3.4].

3.3.10 Thickness of glasses forming screen bulkheads or internal boundaries of deckhouses

The thickness of glasses forming screen bulkheads on the side of enclosed promenade spaces and that for rectangular windows in the internal boundaries of deckhouses which are protected by such screen bulkheads are considered by the Society on a case by case basis.

The Society may require both limitations on the size of rectangular windows and the use of glasses of increased thickness in way of front bulkheads which are particularly exposed to heavy sea.

Ch 8, Sec 10

Insert the following new Table A:

Table A : Equivalent dimensions for windows having other shapes

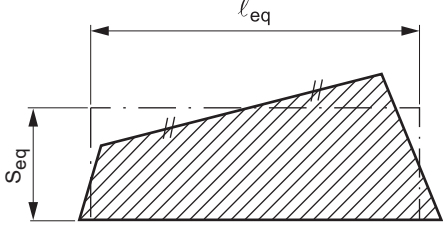
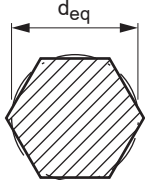
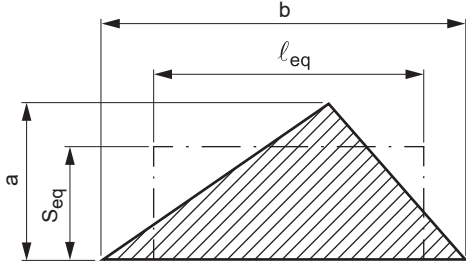
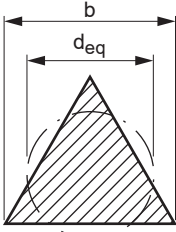
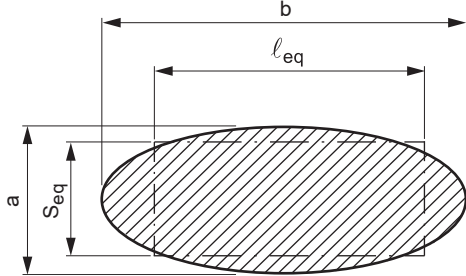
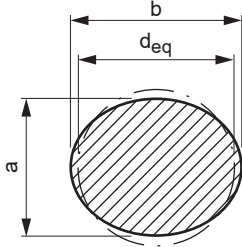
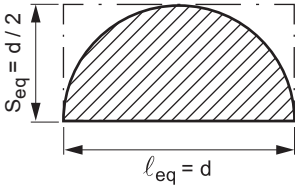
<p>a) Quadrangle</p>  <p>The equivalent rectangle has the same area</p>	<p>b) Polygon</p>  <p>The equivalent circle has the same area</p>
<p>c) Triangle</p>  <p>$s_{eq} = 2a/3$ $l_{eq} = 3b/4$</p>	<p>d) Equilateral triangle</p>  <p>$d_{eq} = 3b/4$</p>
<p>e) Flat ellipse</p>  <p>$s_{eq} = 0,87a$ $l_{eq} = 0,87b$</p>	<p>f) Round ellipse</p>  <p>$d_{eq} = \sqrt{ab}$</p>
<p>g) Semi circle</p>  <p>$s_{eq} = d/2$ $l_{eq} = d$</p>	

Part B

Ch 9, Sec 1, [5.1.4]

Delete the third bullet of the bulleted list.

Ch 9, Sec 3, [1.3]

Replace requirement [1.3.1] by:

1.3.1 General

This type of propeller shaft bracket consists of one arm and may be used only on ships less than 65 m in length.

Ch 9, Sec 3, [1.3.2]

Replace the “M” formula by the following one:

$$M = d_2 0,75 F_C \frac{L}{\ell}$$

Ch 9, Sec 4, [4.2.5]

In Note 1, replace the reference to “Ch 9, App 2, Tab 1” by “Ch 9, App 2, [2]”.

Ch 9, App 2, [2.7.6]

Replace the first bullet of the bulleted list by:

- for ships with one of the service notations oil tanker, chemical tanker, bulk carrier or ore carrier:
 $n = 8,3 \cdot 10^{-4} \cdot A_1 + 4$
- for other ships:
 $n = 8,3 \cdot 10^{-4} \cdot A_1 + 6$

Ch 11, Sec 1

Replaced Figure 10 by:

Figure 10 : Full penetration weld

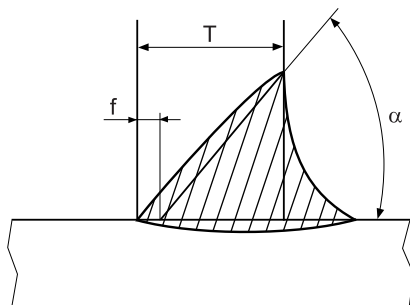

Ch 11, Sec 3

Replace Table 2 by the following:

Table 2 : Test requirements for tanks and boundaries

Item	Tank or boundaries to be tested	Test type	Test head or pressure	Remarks
1	Double bottom tanks (4)	leak and structural (1)	The greater of: <ul style="list-style-type: none"> • top of the overflow (9) • 2,4 m above top of tank (2) • bulkhead deck 	
2	Double bottom voids (5)	leak	See [1.6.4] to [1.6.6], as applicable	Including pump room double bottom and bunker tank protection double hull required by MARPOL Annex I
3	Double side tanks	leak and structural (1)	The greater of: <ul style="list-style-type: none"> • top of the overflow (9) • 2,4 m above top of tank (2) • bulkhead deck 	
4	Double side voids	leak	See [1.6.4] to [1.6.6], as applicable	
5	Deep tanks other than those listed elsewhere in this Table	leak and structural (1)	The greater of: <ul style="list-style-type: none"> • top of the overflow (9) • 2,4 m above top of tank (2) 	
6	Cargo oil tanks	leak and structural (1)	The greater of: <ul style="list-style-type: none"> • top of the overflow • 2,4 m above top of tank (2) • top of tank plus setting of any pressure relief valve (2) 	
7	Ballast holds of bulk carriers	leak and structural (1)	The greater of: <ul style="list-style-type: none"> • top of the overflow • top of cargo hatch coaming 	
8	Peak tanks	leak and structural (1)	The greater of: <ul style="list-style-type: none"> • top of the overflow (9) • 2,4 m above top of tank (2) 	After peak to be tested after installation of stern tube
9	a) Fore peak spaces with equipment	leak	See [1.6.3] to [1.6.6], as applicable	
	b) Fore peak voids	leak	See [1.6.3] to [1.6.6], as applicable	
	c) Aft peak spaces with equipment	leak	See [1.6.3] to [1.6.6], as applicable	
	d) Aft peak voids	leak	See [1.6.4] to [1.6.6], as applicable	After peak to be tested after installation of stern tube
10	Cofferdams	leak	See [1.6.4] to [1.6.6], as applicable	
11	a) Watertight bulkheads	leak (8)	See [1.6.3] to [1.6.6], as applicable (7)	
	b) Superstructure end bulkheads	leak	See [1.6.3] to [1.6.6], as applicable	
12	Watertight doors below freeboard or bulkhead deck	leak (6) (7)	See [1.6.3] to [1.6.6], as applicable	
13	Double plate rudder blades	leak	See [1.6.4] to [1.6.6], as applicable	
14	Shaft tunnels clear of deep tanks	leak (3)	See [1.6.3] to [1.6.6], as applicable	
15	Shell doors	leak (3)	See [1.6.3] to [1.6.6], as applicable	
16	Weather-tight hatch covers and closing appliances	leak (3) (7)	See [1.6.3] to [1.6.6], as applicable	Hatch covers closed by tarpaulins and battens excluded
17	Dual purpose tank/dry cargo hatch covers	leak (3) (7)	See [1.6.3] to [1.6.6], as applicable	In addition to the structural test in item 6 or item 7

Part B

Item	Tank or boundaries to be tested	Test type	Test head or pressure	Remarks
18	Chain lockers	leak and structural	Head of water up to top of chain pipe	
19	L.O. sump tanks and other similar tanks/spaces under main engines	leak (10)	See [1.6.3] to [1.6.6], as applicable	
20	Ballast ducts	leak and structural (1)	The greater of: <ul style="list-style-type: none"> ballast pump maximum pressure setting of any pressure relief valve 	
21	Fuel oil tanks	leak and structural (1)	The greater of: <ul style="list-style-type: none"> top of the overflow 2,4 m above top of tank (2) top of tank plus setting of any pressure relief valve (2) bulkhead deck 	
22	Fuel oil overflow tanks not intended to hold fuel	leak and structural (1)	The greater of: <ul style="list-style-type: none"> top of the overflow (9) 2,4 m above top of tank (2) bulkhead deck 	

- (1)** See [1.4.2], item b).
- (2)** The top of a tank is the deck forming the top of the tank, excluding any hatchways.
- (3)** Hose test may be also considered as a medium of the leak test. See [1.3.2].
- (4)** Including the tanks arranged in accordance with the provisions of Ch 2, Sec 2, [3.1.4].
- (5)** Including the duct keels and dry compartments arranged in accordance with the provisions of SOLAS, Regulations II-1/11.2 and II-1/9.4 respectively, and/or the oil fuel tank protection and pump room bottom protection arranged in accordance with the provisions of MARPOL Annex I, Chapter 3, Part A, Regulation 12A and Chapter 4, Part A, Regulation 22, respectively.
- (6)** Where watertightness of watertight doors has not been confirmed by a prototype test, a hydrostatic test (filling of the watertight spaces with water) is to be carried out. See SOLAS Regulation II-1/16.2 and MSC/Circ.1176.
- (7)** As an alternative to the hose test, other testing methods listed in [1.6.7] to [1.6.9] may be acceptable, subject to adequacy of such testing methods being verified. See SOLAS Regulation II-1/11.1. For watertight bulkheads (item 11 a)), alternatives to the hose test may be used only where the hose test is not practicable.
- (8)** A structural test (see [1.4.2]) is also to be carried out for a representative cargo hold in case of cargo holds intended for in-port ballasting. The filling level required for the structural test of such cargo holds is to be the maximum loading that will occur in-port, as indicated in the loading manual.
- (9)** Test head to the top of overflow does not apply to:
 - Tanks filled by gravity (i.e. sewage, grey water and similar tanks, not filled with pumps). In that case the top of overflow is replaced by the highest point of the filling line
 - Fuel oil overflow tanks not intended to hold fuel and arranged with level alarm.
- (10)** Where L.O. sump tanks and other similar spaces under main engines intended to hold liquid form part of the watertight subdivision of the ship, they are to be tested as per the requirements of Item 5, Deep tanks other than those listed elsewhere in this table.

Amendments to PART C

Ch 1, Sec 2, Table 6 and Table 7

Replace the row “Fuel oil leakage from pressure pipes” as follows:

Table 6 : Monitoring of trunk-piston diesel engines used for auxiliary services

Fuel oil leakage from high pressure pipes	H						
---	---	--	--	--	--	--	--

Table 7 : Monitoring of emergency diesel engines

Fuel oil leakage from high pressure pipes	H	local					
---	---	-------	--	--	--	--	--

Ch 1, Sec 8, [2.6.2]

Replace item e) as follows:

- e) Controllable pitch propeller systems are to be equipped with means of emergency control enabling the controllable pitch propeller to operate when the remote control system fails. This requirement may be complied with by means of a device which locks the propeller blades in the “ahead” setting.

Ch 1, Sec 10, [11.5.3], item d)

Correct “protube” by “protrude”.

Ch 1, Sec 10, Table 5

Replace Table 5 by:

Table 5 : Conditions of use of metallic materials in piping systems

Material	Allowable classes	Maximum design temperature (1)	Particular conditions of use
Carbon and carbon-manganese steels	III, II, I	400 (2)	Class I and II pipes are to be seamless drawn pipes (3)
Copper and aluminium brass	III, II, I	200	<ul style="list-style-type: none"> Not to be used in fuel oil systems, except for class III pipes of a diameter not exceeding 25 mm not passing through fuel oil tanks Not to be used for boiler blow-down valves and pieces for connection to the shell plating
Copper-nickel	III, II, I	300	
Special high temperature resistant bronze	III, II, I	260	
Stainless steel	III, II, I	300	(4) Austenitic stainless steel is not to be used for sea water systems
Spheroidal graphite cast iron / Nodular cast iron	III, II (5)	350	<ul style="list-style-type: none"> Minimum elongation is not to be less than 12% on a gauge length of $5,65.S^{0,5}$, where S is the actual cross-sectional area of the test piece Not to be used for boiler blow-down valves and pieces for connection to the shell plating

Part C

Material	Allowable classes	Maximum design temperature (1)	Particular conditions of use
Grey cast iron / Ordinary cast iron	III, II	220	Grey cast iron/ordinary cast iron is not to be used for the following systems: <ul style="list-style-type: none"> boiler blow-down systems and other piping systems subject to shocks, high stresses and vibrations bilge lines in tanks parts of scuppers and sanitary discharge systems located next to the hull below the freeboard deck or for passenger ships below the bulkhead deck ship side valves and fittings valves fitted on the collision bulkhead valves fitted to fuel oil and lubricating oil tanks under static pressure head class II fuel oil systems and thermal oil systems
Aluminium and aluminium alloys	III, II	200	Aluminium and aluminium alloys are not to be used on the following systems: <ul style="list-style-type: none"> flammable oil systems sounding and air pipes of fuel oil tanks fire-extinguishing systems bilge system in boiler or machinery spaces or in spaces containing fuel oil tanks or pumping units scuppers and overboard discharges except for pipes led to the bottoms or to the shell above the freeboard deck or fitted at their upper end with closing means operated from a position above the freeboard deck boiler blow-down valves and pieces for connection to the shell plating

(1) Maximum design temperature is not to exceed that assigned to the class of piping.
 (2) Higher temperatures may be accepted if metallurgical behaviour and time dependent strength (ultimate tensile strength after 100 000 hours) are in accordance with national or international standards or specifications and if such values are guaranteed by the steel manufacturer.
 (3) Pipes fabricated by a welding procedure approved by the Society may also be used.
 (4) Pipes made of copper and copper alloys are to be seamless.
 (5) Use of spheroidal cast iron / nodular cast iron for class I piping systems will be given special consideration by the Society.

Ch 1, Sec 11, Table 5

Replace the head of Table 5 and add table foot note (3) as follows:

Table 5 : Location of displays and alarms

Item	Display	Alarms (audible and visible)	Location		
			Navigation Bridge	Engine Control Room (3)	Steering gear compartment
(3) Common alarm may be accepted if individual alarms are available locally.					

Ch 1, App 3, Table 2

Replace the rows 6, 7 and 9 by:

Table 2 : Typical requirements for all systems

No	Test	Typical standard	Notes
6	Impact resistance	ISO 9854, ISO 9653, ISO 15493, ASTM D 2444, or equivalent	Representative samples of each type of construction
7	Ageing	Manufacturer's standard ISO 9142	Each type of construction
9	Fluid absorption	ISO 8361	

Ch 1, App 3

Replace Table 3 by:

Table 3 : Typical additional requirements depending on service and/or locations of piping

No	Test	Typical standard	Notes
1	Fire endurance (1) (2) (3)	IMO Res. A753(18), Appendix 1, 2	Representative samples of each type of construction and type of pipe connection
2	Flame spread (1) (2) (3)	the present [2.3.2]	Representative samples of each type of construction
3	Smoke generation (2) (3)	IMO Fire Test Procedures Code	Representative samples of each type of construction
4	Toxicity (2) (3)	IMO Fire Test Procedures Code	Representative samples of each type of construction
5	Electrical conductivity (1) (2) (3)	ASTM F1173-95 or ASTM D 257, NS 6126 § 11.2 or equivalent	Representative samples of each type of construction
<p>(1) Test to be witnessed by a Surveyor of the Society. (2) If applicable (3) Optional. However, if the test is not carried out, the range of approved applications for the pipes is to be limited accordingly.</p>			

Ch 2, Sec 4

Delete "Publication" in the references "IEC Publication x" in the following listed requirements:

- [3.1.2] first paragraph
- [4.5.1]
- [4.6.1], first paragraph
- [4.6.2], first paragraph
- [4.8.1]
- [4.9.1]
- [4.9.3]
- [4.11.1].

Ch 2, Sec 4, [3.3.1]

Correct "proptotype" by "prototype"

Ch 2, Sec 5, Table 2

Replace row 9 and add table foot note (4) as follows:

Table 2 : Tests to be carried out on transformers

9	Temperature-rise measurement	X (4)	
(4) Temperature rise test may be omitted for starting transformer.			

Ch 2, Sec 7, [1]

Insert the following new sub-article [1.4]:

1.4 Li Ion batteries

1.4.1 For Li Ion batteries used as emergency source or transitional source or of capacity above 20kWh, the requirements specified in additional notation **BATTERY SYSTEM** in Part F, Ch 11, Sec 21 apply.

Part C

Ch 2, Sec 13

Delete “Publication” in the reference “IEC Publication x” in the following listed requirements:

- [2.2.1]
- [3.3.1]
- [4.1.1], in the first and second paragraph
- [5.1.1]
- [6.1.1]
- [6.2.1], two times
- [6.4.1].

Ch 2, Sec 13, [7.1.1]

Replace the last paragraph by:

An adequate, unobstructed working space is to be left in the vicinity of high voltage equipment for preventing potential severe injuries to personnel performing maintenance activities. In addition, the clearance between the switchboard

and the ceiling / deckhead above is to meet the requirements of the Internal Arc Classification according to IEC 62271-200. See [6.2.5]

Ch 2, Sec 14, [2.5]

Replace sub-article title as follows:

2.5 Excitation of synchronous electric propulsion motor

Replace requirement [2.5.3] by:

2.5.3 In case of multi-propeller propulsion ships, standby exciter may be omitted, provided failure of one exciter on one electric motor doesn't impair the functionality of the remaining motor.

Ch 4, Sec 2, [2.2.2]

Replace item c) as follows:

c) *Total volume of combustible materials*
Where combustible materials are used in accordance with the previous item a), the total volume of combustible facings, mouldings, decorations and veneers in accommodation and service spaces shall not exceed a

volume equivalent to 2,5 mm veneer on the combined area of the walls and ceiling linings. Furniture fixed to linings, bulkheads or decks need not be included in the calculation of the total volume of combustible materials.

Ch 4, Sec 8, [2.6.1], item a)

Replace “A.760(18)” by “A.1116(30)”.

Ch 4, Sec 11, [2.6.1]

Delete Note 1.

Ch 4, Sec 11, [2.6]

Replace requirement [2.6.6] by:

2.6.6 When the bilge pump is located directly inside a container cargo space, the requirement [2.6.5] may apply in lieu of [2.5.1]. In such a case, Note 1 of Tab 19 may be applied to the container cargo space containing the bilge pump. In case several container cargo spaces are served by

the same bilge pump, the bilge pump is to be installed in the container cargo hold with the highest ventilation rate

Bilge drainage pipes should not pass through the engine room unless they are reinforced and joined by welding.

Ch 4, Sec 14, [4.1.2], item a)

Replace item 4) as follows:

- 4) The percentages specified in item 3) above may be reduced to 35% and 30%, respectively, for cargo ships of less than 2000 gross tonnage.

In this case, where two or more machinery spaces are not entirely separate, they are to be considered as forming one space.

Ch 4, Sec 14, [13.2.4]

Replace item a) as follows:

- a) *The operation status of the inert gas system shall be indicated in a control panel.*

The operational status of the inert gas system is to be based on indication that inert gas is being supplied upstream of the gas regulating valve and on the pressure or flow of the inert gas mains upstream of the non-return

devices. However, the operational status of the inert gas system is not to be considered to require additional indicators and alarms other than those specified in this requirement and [13.3.3] or [13.4.3], as appropriate.

Amendments to PART D

Ch 6, Sec 2

In requirements [3.2.6], [4.2.5], [3.2.3]: replace “MEPC.66(37)” by “MEPC.110(49)”

Ch 7 Sec 2, [3.2.3]

Replace the reference to “MEPC.66(37” by “MEPC.110(49)“.

Ch 8, Sec 2, [6]

Insert the following new sub-article [6.4]:

6.4 Survival criterion

6.4.1 Unprotected openings

IBC CODE REFERENCE: Ch 2, 2.9.3.1

Other openings capable of being closed weathertight do not include ventilators (complying with ILLC 19(4)) that for

operational reasons have to remain open to supply air to the engine room or emergency generator room (if the same is considered buoyant in the stability calculation or protecting openings leading below) for the effective operation of the ship.

Ch 8, Sec 5, [6.1.1]

Correct “incentive” by incendive”.

Ch 8, Sec 8, [1.1.1]

Replace IBC Code reference “Ch 8, 8.2.2” by “Ch 8, 8.2.3”.

Ch 8, Sec 8, [2.1]

Insert the following new requirement [2.1.2]:

2.1.2 By-passing of P/V valves

IBC CODE REFERENCE: Ch 8, 8.3.2

By-passing of P/V valves is allowed during cargo operations for cargoes which do not require a vapor return system, provided that the vent-line outlet is fitted with flame arresters and is located at the required height above the deck level. However, by-passing of high-velocity valves is not permitted.

Ch 8, Sec 10, [1.5.5]

Replace the reference to “Ch 7, Sec 5, [1.5.4]” by “[1.5.4]”.

Ch 8, Sec 11

Insert the following new Article [1]:

1 General**1.1 Application****1.1.1 Fire-fighting**

IBC CODE REFERENCE: Ch 11, 11.1.1.3 and

IBC CODE REFERENCE: Ch 11.1.1.4

Ships having the service notation **chemical tanker** are to comply with the requirements of:

- Pt C, Ch 4, Sec 6 [1],
- Pt C, Ch 4, Sec 6 [3] and
- Pt C, Ch 4, Sec 6 [4] except Pt C, Ch 4, Sec 6 [4.7]

regardless of the size of the ship.

- Pt C, Ch 4, Sec 6 [4.7] only for ships of 2000 gross tonnage and above.

Ch 8, Sec 15, [4]

Insert the following new sub-article [4.1]:

4.3 Lining for tanks and piping**4.3.1 Lining approved for use with acids**

IBC CODE REFERENCE: Ch 15, 15.11.2

"Lining" is an acid-resistant material that is applied to the tank or piping system in a solid state with a defined elasticity property.

Ch 8, Sec 15, [4.2]

Replace the existing requirement [4.2.1] by:

4.2.1 Electrical equipment

IBC CODE REFERENCE: Ch 15, 15.11.5

Hazardous areas are to be defined as per Sec 10 Tab 2. Electrical materials and equipment are to have minimum explosion group IIC or IIB+H2 and temperature class T1.

Ch 9, Sec 5, [13.3.1]

Insert the following Note 1 and Note 2 at the end of the first item of the bulleted list:

Note 1: for pressure relief valves (PRVs) that are subject to requirement of Ch 9, Sec 8 [2.1.7], the flow or capacity are to be certified by the Society.

Note 2: for other types of valves describe in note 1, the manufacturer is to certify the flow properties of the valves based on tests carried out according to recognized standards.

Ch 9, Sec 11, [1.3.2], item g)

Insert the following Note 1 at the end of item g):

g) exposed lifeboats, liferafts and muster stations facing the cargo area, regardless of distance to cargo area, and

Note 1: Water spray protection should be considered for exposed embarkation stations and exposed launching routes from the life

rafts stowage location to the ship side unless the life rafts are located and ready for launching at both sides.

Ch 9, Sec 16, [4.5.3]

Replace item a) as follows:

a) whenever the gas pressure varies by more than 10% or, in the case of supercharged engines, if the differential pressure between gas and charging air is no longer constant.

Part D

Ch 9, App 1, [2]

Replace sub-article title [2.2] by:

2.2 Sloshing pressure for membrane tanks

Ch 11, Sec 3, [6]

Add the following new sub-article [6.2]:

6.2 Balcony doors

6.2.1 General

Glazed sliding doors fitted on sides of superstructures are to comply with the following requirements:

- Pt B, Ch 8, Sec 10, [3.3] for the assessment of glass panes
- [6.2.2] for the structural testing of supporting frames.

6.2.2 Supporting frame structural testing

Strength test of balcony doors supporting frames is to be carried out according to the following procedure:

- the structural testing is to be carried out at twice the design pressure as defined in Pt B, Ch 8, Sec 4, [2]

- the door assembly, its supporting frame and supporting structure are to be same as, or deemed representative of the ship actual arrangement
- the pressure is to be applied uniformly on the door entire external area
- the glass panel may be alternatively replaced by a steel plate, of reduced thickness in order to represent equivalent flexural stiffness of the glass
- the pressure is to be maintained for not less than 5 minutes
- visual inspection is to be carried out after testing, without damage nor deformation.

Ch 13, Sec 2

Replace Table 1 by:

Table 1 : Coefficient n_D in dredging situation

Operating area	$L \leq 110$ m	$110 \text{ m} < L \leq 150$ m	$150 \text{ m} < L \leq 180$ m	n_D
dredging within 8 miles from shore	N.A.			1/3
dredging over 8 miles from shore with ...	$H_s \leq 1,5$ m	$H_s \leq 2,0$ m	$H_s \leq 2,0$ m	1/3
dredging within 15 miles from shore or within 20 miles from port	N.A.			2/3
dredging over 15 miles from shore with ...	$H_s \leq 2,5$ m	$H_s \leq 3,0$ m	$H_s \leq 3,5$ m	2/3
dredging over 15 miles from shore	N.A.			1
Note 1: H_s : Maximum significant wave height, in m. etc.				
Note 2: N.A. = Not Applicable				

Ch 14, Sec 2, [6.1.3]

Replace the second paragraph by:

The Society may, at the specific request of the interested parties, check the shipboard fittings and supporting hull structures associated to towing arrangements; to this end, the maximum pull for which the arrangements are to be checked is to be specified on the plans.

Amendments to PART E

Ch 1, Sec 1, Table 1

Replace the rows “Hull” as follows:

Table 1 : Applicable requirements

Item		Greater than or equal to 500 GT	Less than 500 GT
Hull	L ≥ 90 m	<ul style="list-style-type: none"> Part B Ch 1, Sec 3 	<ul style="list-style-type: none"> Part B Ch 1, Sec 3
	L < 90 m	<ul style="list-style-type: none"> NR600 Ch 1, Sec 3 	<ul style="list-style-type: none"> NR600 Ch 1, Sec 3

Ch 1, Sec 2

Insert the following new Article [2]:

2 Openings

2.1 General

2.1.1 Openings which cannot be closed weathertight

Openings in the hull, superstructures or deckhouses which cannot be closed weathertight are to be considered as unprotected openings and, consequently, as down-flooding points for the purpose of stability calculations (the lower edge of such openings is to be taken into account).

2.1.2 Ventilation openings of machinery space and emergency generator room

It is recognised that for tugs, due to their size and arrangement, compliance with the requirements of ICLL Reg. 17(3) for ventilators necessary to continuously supply the machinery space and the emergency generator room may not be

practicable. Lesser heights of the coamings of these particular openings may be accepted if the openings:

- are positioned as close to the centreline and as high above the deck as practicable in order to maximise the down-flooding angle and to minimise exposure to green water
- are provided with weathertight closing appliances in combination with suitable arrangements, such as separators fitted with drains
- are equipped with efficient protective louvers and mist eliminators
- have a coaming height of not less than 900 mm above the deck
- are considered as unprotected openings and, consequently, as down-flooding points for the purpose of stability calculations.

Ch 1, Sec 2, [2.1.3]

Replace the definition of “r” by:

r : Transverse offset, in m, between the towing point and the ship’s centerline.
The towing point is the location where the tow-line force is applied to the ship (fairlead, staple, towing hook or equivalent fitting).

When the towing point is not at the center line, the most unfavourable tow line position is to be considered.

Part E

Ch 1, Sec 3, [2.4.2]

Replace the third paragraph by:

Escape hatch covers are to have hinges fitted such that the predominant direction of green sea will cause the cover to close and are to be capable of being opened and closed weathertight from either side.

Ch 7, Sec 1, Table 3

Insert new rows 4 and 10 as follows:

Modify existing row 8 by:

Table 3 : Documents to be submitted

No.	Documents to be submitted	I / A (1)
Structural assessment		
4	Description of the seafastening, if any	I
Electrical installations		
8	Descriptions and details of any communication means as required by the Rules, including single line diagram	A
10	Description and details of the lighting arrangement around the diving system	A

Ch 7, Sec 2, [2]

Insert new sub-article [2.1]

2.1 General

2.1.1 There is to be a sufficient level of access available around the diving system in order to allow operational personnel to safely and efficiently carry out their duties.

Ch 7, Sec 4, [3.1.3]

Replace the requirement by:

3.1.3 Main and automatic emergency lightings are to be provided in spaces containing diving equipment.

Ch 7, Sec 4

Add new Article [5]:

5 Diver heating system

5.1 Oil fired heaters

5.1.1 When diver heating system includes oil fired heaters, they are to be located such that they present no risk to the dive system in the event of fire.

5.1.2 The local tank is to be fitted with an overflow system with a capacity greater than the filling supply system (i.e. capable of allowing a rate of overflow greater than the filling rate).

5.1.3 The overflow system is to dump to a safe area.

Ch 7, Sec 7, [2.1.1]

Replace item c) as follows:

- c) Verification of the sea fastening arrangement of the diving equipment. If the sea fastening requires any welded fixtures then there is to be Non Destructive Testing reports available confirming these welds were satisfactorily tested

Ch 8, Sec 1, [1.1]

Add the following new requirement [1.1.4]:

1.1.4 Ships fitted with legs for self-elevating purposes

When the vessel is fitted with legs for self-elevating purpose, the additional service feature self-elevating is to be assigned in accordance with Pt A, Ch 1, Sec 2, [4.9] and the requirements of Sec 7 are to be complied with.

Ch 8, Sec 1, [1.2]

Add the following new requirement [1.2.2]:

1.2.2 Specific requirements for ships fitted with legs for self-elevating purposes are also addressed in Sec 7.

Ch 8, Sec 4, [7.5]

Replace requirement [7.5.1] and [7.5.2] by:

7.5.1 For uniaxial stress condition (e.g. obtained by beam calculation), the following stress components are to be calculated:

- the normal stress σ_1 in the direction of the beam axis
- the shear stress τ_{12} in the direction of the local loads applied to the beam
- the Von Mises equivalent stress, obtained from the following formula:

$$\sigma_{VM} = \sqrt{\sigma_1^2 + 3\tau_{12}^2}$$

Above stresses are the result of the addition of overall stresses and grillage stresses.

7.5.2 For biaxial stress condition (e.g. obtained by finite element calculation with plate elements), the following stress components are to be calculated at the centroid of the mid-plane layer of each element:

- the normal stresses σ_1 and σ_2 in the directions of the element co-ordinate system axes
- the shear stress τ_{12} with respect to the element co-ordinate system axes
- the Von Mises equivalent stress, obtained from the following formula:

$$\sigma_{VM} = \sqrt{\sigma_1^2 + \sigma_2^2 - \sigma_1\sigma_2 + 3\tau_{12}^2}$$

The stresses in the element under study, include the effects of both overall and local loads.

Chapter 8

Add the following new Section 7:

SECTION 7

SELF-ELEVATING SHIPS

1 General

1.1 Application

1.1.1 The present Section is applicable to ships or barges fitted with legs and capable of being lowered to the sea bed and of raising the hull above the sea level, hereafter defined as self-elevating ships (see [3.1]).

The present Section addresses the requirements regarding structural assessment of the hull in elevated position, the elevating system and the specific fire safety features.

1.1.2 Self-elevating ships complying with the requirements of this Section are eligible for the assignment of the additional service feature **self elevating** to complete the service notations assigned to the ship as defined in Pt A, Ch 1, Sec 2, [4.9].

1.1.3 The Party applying for classification is to provide the most unfavourable environmental conditions for which the self-elevating ship is designed, as stipulated in [6]. These conditions are to be reported in the Design Criteria Statement defined in [2.2].

All changes of the stipulated environmental conditions are to be submitted to the examination of the Society and the design criteria statement may be modified accordingly after approval of the design for the new conditions and, if applicable, execution of the necessary reinforcements.

1.2 Applicable rules and regulations

1.2.1 In addition to the requirements that ships are to comply with for granting a service notation defined in Pt A, Ch 1, Sec 2, [4.9], ships assigned with the additional service feature **self elevating** are to comply with:

- the requirements for hull structure listed in [1.2.2], taking into account the specific structural requirements for elevated position
- the requirements for machinery, electrical installations, and automation listed in [1.2.2], taking into account the specific requirements for jacking system
- the requirements for fire safety listed in Article [9].

1.2.2 Self-elevating ships are to comply with the relevant requirements of NR534, as specified in:

- Article [5] for structure design principles
- Article [6] for design and environmental conditions
- Article [7] for structural analysis, in elevated position (see [7.1]) or transit and installations conditions (see [7.2])
- Article [8] for jacking system
- Article [10] for construction survey.

Note 1: NR534 Rules for the classification of self elevating units - jackups and liftboats, as amended.

1.2.3 The attention is drawn to certain national or international regulations that may be required by the Administration.

Note 1: e.g. IMO MODU Code (IMO Resolution A.1023(26) - Code for the construction and equipment of mobile offshore drilling unit) applicable to self-elevating units.

2 Classification principles

2.1 Classification limits

2.1.1 Site conditions

It is incumbent to the owner or operator:

- to perform the necessary investigations, including environmental and geotechnical surveys, prior to operating the unit at a given site
- to ascertain that the actual conditions met at the contemplated operating site remain on the safety side when compared to the design data and assumptions (particularly those listed in the design criteria statement, as defined in [2.2]). Such site assessment is not part of the classification.

Classification does not cover the following items:

- assessment of sea bottom conditions and geotechnical investigations
- prediction of footing penetration during preloading
- the stability of the foundation after preloading
- assessment of the possible sea floor movement.

2.1.2 Operating procedures

Classification does not cover the procedures to be used for the unit positioning, leg jacking (lowering or elevating), preloading, jacking and other procedures related to operations.

It is the responsibility of the owner operator to ascertain that the said procedures and their implementation satisfy the design criteria of the ship and the design of the related equipment.

2.2 Design criteria statement

2.2.1 Classification is based upon the design data or assumptions specified by the party applying for classification in accordance with [1.1.3].

A design criteria statement is to list the service(s) performed by the ship and the design conditions and other assumptions on the basis of which class is assigned.

The design criteria statement is issued by the Society, based on the information provided by the party applying for classification.

The design criteria statement is to be incorporated in the operating manual (see [4.2]).

2.2.2 The description of the most unfavourable environmental conditions for which the ship is designed to operate in elevated position, as defined in [1.1.3] is to be included in the design criteria statement as per Article [6].

Figure 1 : Self-elevating ship

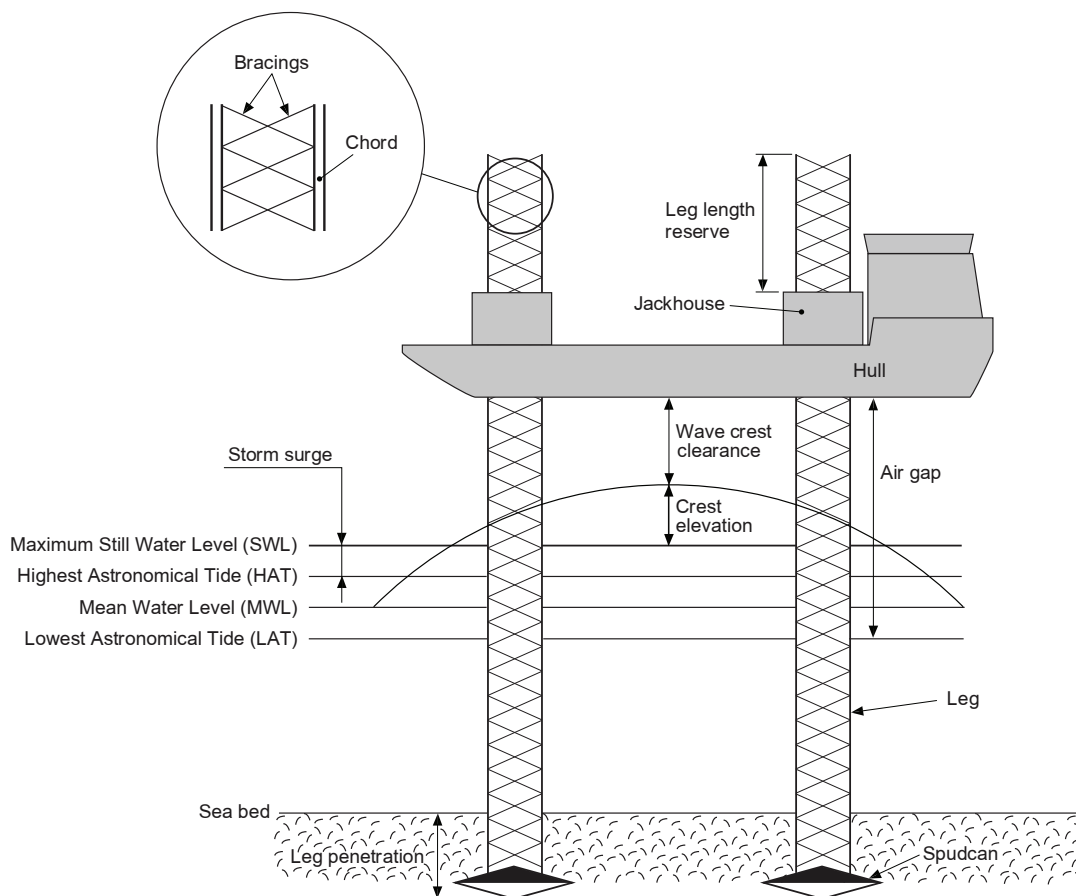

3 Definitions

3.1 Self-elevating ship

3.1.1 A self-elevating ship is a ship or a barge fitted with legs and capable of being lowered to the sea bed and of raising the hull above the sea level (see Fig 1).

The legs may be:

- of a shell or truss type
- equipped with a lower mat, a spudcan, a gravity-based structure or with footings designed to penetrate the sea bed
- vertical or slanted.

3.2 Modes of operation

3.2.1 A self-elevating ship is designed to resist to the loads occurring during working, survival, transit, installation and retrieval modes:

- working mode: the ship is on location, supported on the sea bed to operate, and combined environmental and operational loading are within the appropriate design limits established for such operations
- survival mode: the ship is on location, supported on the sea bed and may be subjected to the most severe environmental loading for which it is designed

- transit mode: the ship moves from one location to another within the appropriate limits the ship is designed to
- installation mode: period when the ship is firstly lowering legs to the sea bed, secondly elevating hull at the required elevation above the sea level, and then preloading the legs to the extreme loading
- retrieval mode: period when the ship is lowering the hull and then elevating legs to be ready for transit mode.

3.3 Water levels, crest elevation and water depth

3.3.1 The reference water levels and crest elevation are defined as follows in the present Section (see Fig 1):

- mean water level (MWL): mean level between the highest astronomical tide (HAT) and the lowest astronomical tide (LAT)
- astronomical tidal range: range between the highest astronomical tide (HAT) and the lowest astronomical tide (LAT)
- maximum still water level (SWL): level at the highest astronomical tide (HAT) including storm surge
- crest elevation: height of wave crest above the SWL.

3.3.2 Except otherwise specified, the reference water depth to be considered is the distance between the sea bed and the SWL.

3.4 Configuration of a self-elevating unit in elevated position

3.4.1 The configuration of a self-elevating ship in elevated position is to be defined based on the site data associated with the ship's services, as specified in accordance with [1.1.3].

3.4.2 The configuration is defined with the following parameters (see Fig 1):

- leg penetration length: the leg penetration length is the maximum leg penetration into the sea bed, including the spudcan if any
- leg length reserve: the leg length reserve is the reserve above the upper guide to avoid any soil settlement or punch through and to provide a contingency in case the penetration exceeds the predicted one
- air gap: the air gap is defined as the distance between the underside of the hull and the lowest astronomical tide (LAT)
- wave crest clearance: the wave crest clearance is defined as the distance between the highest wave crest and the underside of the hull.

4 Documents to be submitted

4.1 General

4.1.1 Documents listed in Tab 1 are to be submitted for approval or information.

4.2 Operating manual

4.2.1 An operating manual, including instructions regarding the safe operation of the ship and of the elevating systems is to be placed on board.

The operating manual is to be, at all times, made available to all concerned. A copy of the operating manual is to be retained ashore by the owner of the ship or by his representatives.

The operating manual is to incorporate a dedicated section containing all the information relating to classification, particularly the environmental, loading and other design criteria, as well as the classification restrictions. The operating manual of a self-elevating ship is also to stipulate the instructions related to the transit conditions, the preloading and the emergency procedures in case of punch through.

It is the responsibility of the party applying for classification to prepare the contents of the operating manual.

Table 1 : Documents to be submitted

No.	Document	A/I (1)
1	Operating manual as defined in [4.2]	A
2	Descriptions of the environmental loads including forces and moments from wind, waves, currents, ice, snow, earthquakes, as applicable as per [6.1]	I
3	Structural analysis of the unit in elevated position	I
4	Calculations of the unit resistance against overturning while resting on the sea bed in elevated position	I
5	Leg strength calculation in floating condition	I
6	Local strength calculations of: <ul style="list-style-type: none"> • legs • leg/hull connection • spudcans or bottom mat, if relevant • leg/spudcan or leg/mat connection, if relevant 	I
7	Fatigue calculations of structural details, when relevant	I
8	Calculations of jacking systems and, if any, fixation systems	I
9	Calculations of segregation of loads between jacking and fixation systems, if relevant	I
10	General arrangement in elevated position	I
11	Drawings of the legs including: <ul style="list-style-type: none"> • for lattice legs: racks, chords, bracings and their connections • for shell type legs: shell plating, stiffeners, stringers, struts, connections of racks with shell plating and supporting leg rack members, potential openings, where relevant 	A
12	Detailed drawings of the racks, if any, including their arrangement in transit and elevating conditions	A
13	Drawings of the footings (spudcans) or mats	A
14	Drawing of the leghouses and their attachments with the hull	A
15	Description of the jacking system as required in NR534, Section 10	(2)
16	Arrangement of the fire-fighting system in elevated position	A
(1) A : for approval; I : for information		
(2) As per NR534, Sec 10, Tab 1		

4.2.2 The operating manual is to be submitted to the Society for review, this review being limited to check that the classification related material as mentioned above is consistent with the data given in the design criteria statement defined in [2.2].

4.2.3 The operating manual is to include the following information, where applicable:

- design limitations:
 - during transit (leg arrangement, rig and other equipment sea fastening)
 - during installation (leg lowering, preloading)
 - on site
 - during retrieval (hull lowering, leg retrieval)
- emergency procedures in case of punch through
- preload procedure
- or normal operation, information regarding the preparation of the ship to avoid structural damage during the setting or retraction of legs on or from the seabed, or during extreme weather conditions while in transit, including the positioning and securing of legs
- jacking gear main loading capacity in operating conditions
- maximum loading capacity in case of engaged fixation system
- design criteria statement including the classification restrictions, if any.

5 Structure design principles

5.1 General

5.1.1 The structure design principles applicable for the legs, the leghouses and the spudcans or bottom mat are to be in accordance with NR534, Section 2.

6 Design conditions

6.1 General

6.1.1 The design conditions applicable for the design of the legs, the leghouses, the spudcans or bottom mat and the elevating system, are to be in accordance with NR534, Section 3 as amended by [6.2] for elevated configuration, [6.3] for transit configuration and [6.4] for installation conditions.

6.2 Design conditions in elevated configuration

6.2.1 The most unfavourable wave, current and wind loads to be considered in elevated configuration are to be provided for both working and survival modes.

The area of operation and the description of sea state are to be provided in accordance with NR534, Section 4.

6.2.2 Environmental loads to be considered for accidental conditions such as a broken bracing on a lattice leg may be specially considered subject to the agreement of the Society.

6.3 Transit conditions

6.3.1 Simplified approach

The structural assessment of the legs, the leghouses, the spudcans or bottom mat and the elevating system in transit conditions, is to be based on the motions and accelerations derived from Part B, Chapter 5.

The greatest transversal and longitudinal metacentric heights (GMT and GML) are to be taken from the trim and stability booklet for the calculation of the roll and pitch motions and accelerations.

Note 1: When the condition $L/B > 5$ is not met, a direct assessment of the environmental loads as per [6.3.2] is recommended.

6.3.2 Direct calculation approach

Subject to the agreement of the Society, specific environmental conditions may be considered for the structural assessment of the legs, the leghouses and the spud cans or bottom mat in transit conditions.

In that case, a hydrodynamic analysis is to be performed in accordance with NR534, Appendix 1.

6.4 Installation conditions

6.4.1 The impact loads during installation are to be taken into account as per NR534, Sec 6, [5].

7 Structural analysis

7.1 Structural analysis in elevated position

7.1.1 The structural analysis in elevated position of the legs, the leghouses, the spudcans or bottom mat, the elevating system and the hull, are to be conducted in accordance with NR534, Section 5, considering the wave and wind loads defined in [6.2].

7.1.2 When the self-elevating ship is fitted with lifting appliances intended to be used in elevated position, the lifting loads, defined in Sec 4, [5] are to be taken into consideration for the structural assessment of the elevated hull, the legs and the leghouses.

7.1.3 When fatigue calculations are to be submitted in accordance with NR534, Sec 5, [6.5], the damage ratio criteria are to be selected among the ones applicable to the details accessible for dry inspection.

7.2 Structural analysis in transit conditions and installations conditions

7.2.1 The legs, the leghouses, the spudcans or bottom mat and the self-elevating system are to be designed to sustain the loads induced by the ship motions and accelerations in transit considering the design loads defined in [6.3] and the loads induced by impact, preloading and punch through during installation phase.

7.2.2 The leg structure is to be examined in transit according to the inertia and wind loads distributed along the legs.

7.2.3 The forces and moments induced by the legs are to be considered for the verification of local reinforcements in way of the guides.

7.2.4 The structural assessment to be performed on the legs, the leghouses and the spudcans or bottom mat, are described in NR534, Sec 6, [3], exclusive of the hull and superstructure design requirements.

7.2.5 Spudcans and bottom mat scantling is also to comply with requirements from NR534, Sec 6, [7.2].

8 Jacking system

8.1 General

8.1.1 The design and construction of the jacking system is to comply with the requirements of NR534, Section 10.

8.2 Electricity and automation

8.2.1 The jacking system is to be considered as an essential service.

9 Fire and safety

9.1 Firefighting water supply

9.1.1 At least two water supply sources (sea chests, valves, strainers and pipes) are to be provided and be so arranged that one supply source failure will not put all supply sources out of action.

The following additional fire water supply measures are to be provided:

- in elevated position, water is to be supplied from sea water main filled by at least two submersible pumping systems. One system failure is not to put the other system(s) out of function
- water is to be available while the ship is lifting or lowering. The water stored is to be not less than 40 m³ plus the engines cooling water consumptions before the ship is lifting or lowering. Alternatively, water may be supplied from buffer tank(s) in which the sea water stored is not less than the quantity mentioned above.

10 Construction survey

10.1 Self-elevating system

10.1.1 The construction survey of the self-elevating system, the legs, the leghouses and the spudcans or the bottom mat is performed in accordance with NR534, Section 9.

Amendments to PART F

Ch 2, Sec 2, [2.3.2]

Replace the reference to “Ch 2, Sec 1, [1.2.6]” by “Ch 2, Sec 2”.

Ch 3, Sec 1, [5.1]

Replace requirement [5.1.3] by:

5.1.3 The alarm system is to be designed to function independently of control and safety systems, so that a failure or malfunction of these systems will not prevent the alarm sys-

tem from operating. Common sensors for alarms and automatic slowdown functions are acceptable as specified in each specific table.

Ch 3, Sec 1, Table 28

Replace the row “Fuel oil leakage from pressure pipes” as follows:

Table 28 : Auxiliary trunk-piston reciprocating I.C. engines driving generators

Fuel oil leakage from high pressure pipes	H						
---	---	--	--	--	--	--	--

Ch 3, Sec 4, [6.3.2]

Replace the reference to “Ch 3, Sec 1, [4.2]” by “Ch 3, Sec 1, [4.3]”.

Ch 4, Sec 1, Table 2

Correct “Speed Distance and Measuring Equipment (SDME)” by “Speed and Distance Measuring Equipment (SDME)” in the fourteenth row.

Ch 4, Sec 2, Table 1

Correct “Speed Distance and Measuring Equipment (SDME)” by “Speed and Distance Measuring Equipment (SDME)” in the sixteenth row.

Ch 8, Sec 1, [2.2]

Replace requirements [2.2.2] and [2.2.3] as follows:

2.2.2 Minimum draught

The ship is always to be loaded down at least to the draught of LIWL amidships when navigating in ice. Any ballast tank

situated above the LIWL and needed to load down the ship to this waterline is to be equipped with devices to prevent the water from freezing.

Part F

2.2.3 Minimum forward draught

In determining the LIWL, due regard is to be paid to the need to ensure a reasonable degree of ice going capability in ballast. The highest point of the propeller is to be submerged and if possible at a depth of at least h_i below the water surface in all loading conditions. The minimum forward draught is to be at least equal to the value T_{AV} , in m, given by the following formula:

$$T_{AV} = (2 + 0,00025\Delta_1)h_i$$

where:

Δ_1 : Displacement of the ship, in t, determined from the waterline on the UIWL, as defined in [2.2.1]. Where multiple waterlines are used for determining the UIWL, the displacement must be determined from the waterline corresponding to the greatest displacement.

h_i : Ice thickness, in m, as defined in [2.3].

The draught T_{AV} need not, however, exceed $4 h_i$.

Ch 8, Sec 1, [2.3.1]

Replace “ h_0 ” by “ h_i ” in items a) and c) of the alphabetic list.

Ch 8, Sec 1

Replace Table 2 by:

Table 2 : Ice load height

Notation	h_i (m)	h (m)
ICE CLASS IA SUPER	1,0	0,35
ICE CLASS IA	0,8	0,30
ICE CLASS IB	0,6	0,25
ICE CLASS IC ICE CLASS ID	0,4	0,22
YOUNG ICE 1 YOUNG ICE 2	0,3	0,19

Ch 8, Sec 1, [3.1.1]

Replace the first paragraph by:

The engine output, P, is the total maximum output the propulsion machinery can continuously deliver to the propeller(s). If the output of the machinery is restricted by technical means or by any regulations applicable to the

ship, P is to be taken as the restricted output. If additional power sources are available for propulsion power (e.g. shaft motors), in addition to the power of the main engine(s), they are also to be included in the total engine output.

Ch 8, Sec 1, [3.1.3]

Replace “minimum draught” by “minimum draught amidship” in the first paragraph.

Ch 8, Sec 1, Table 3

Replace the title as follows:

Table 3 : Values of K_C
for conventional propulsion systems

Ch 8, Sec 2, [1.3.1]

Replace “plating” by “plating (ice belt)” in the first item of the bulleted list.

Ch 8, Sec 2, Table 1

Add the row "YOUNG ICE" at the end of Table 1:

Table 1 : Vertical extension of ice strengthened area for plating (ice belt)

Notation	Hull region	Vertical extension of ice strengthened area, in m	
		Above UIWL	Below LIWL
YOUNG ICE 1	Bow	0,40	0,50
YOUNG ICE 2			

Ch 8, Sec 2

Replace Figure 1 by:

Figure 1 : Ice strengthened area and regions

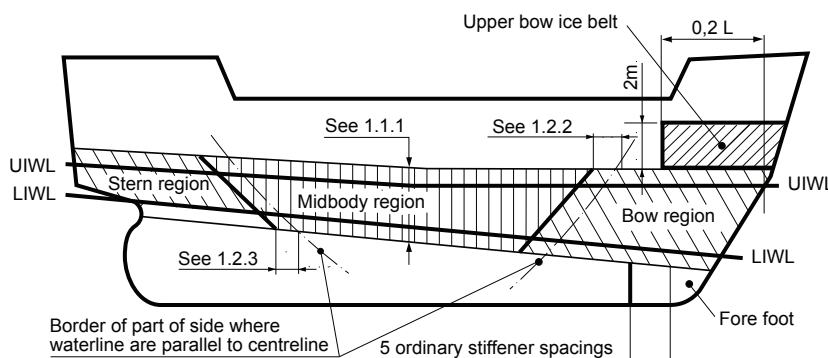

Ch 8, Sec 2

Replace Table 2 by:

Table 2 : Vertical extension of ice strengthening for ordinary stiffeners and primary supporting members

Notation	Hull region	Vertical extension of ice strengthened area, in m	
		Above UIWL	Below LIWL
ICE CLASS IA SUPER	Bow	1,20	Down to tank top or below top of floors
	Midbody		2,00
	Stern		1,60
ICE CLASS IA	Bow	1,00	1,60
ICE CLASS IB	Midbody		1,30
ICE CLASS IC ICE CLASS ID	Stern		1,00
YOUNG ICE 1 YOUNG ICE 2	Bow	0,40	0,50

Note 1: Where an upper bow ice belt is required (see [4.2.1]), the ice-strengthened part of the framing is to be extended at least to the top of this ice belt.

Note 2: Where the ice strengthened area extends beyond a deck, the top or bottom plating of a tank or tank top by not more than 250 mm, it may be terminated at that deck, top or bottom plating of the tank or tank top.

Ch 8, Sec 2, [1.3]

Replace requirements [1.3.2] and [1.3.3] by:

1.3.2 Fore foot

The fore foot is the area below the ice belt extending from the stem to a position five ordinary stiffeners spacings aft of the point where the bow profile departs from the keel line (see Fig 1).

Ch 8, Sec 2, [2.1.4]

Replace the first paragraph by:

Within the ice-strengthened area defined in [1.3], all ordinary stiffeners are to be effectively attached to all the supporting structures. A longitudinal ordinary stiffener is to be attached by brackets to all the supporting web frames and bulkheads. When a transverse ordinary stiffener terminates

Ch 8, Sec 2, [2.1]

Replace requirements [2.1.5], [2.1.6] and [2.1.7] by:

2.1.5 Within the ice-strengthened area defined in [1.3], all ordinary stiffeners are to be attached to the shell by double continuous welds; no scalloping is allowed (except when crossing shell plate butts).

2.1.6 Within the ice-strengthened area defined in [1.3], the web thickness of the frames is to be at least the maximum of the following:

- $\frac{h_w \sqrt{R_{eH}}}{C}$

where h_w is the web height and C is equal to 805 for profiles and 282 for flat bars

- half of the net thickness of the shell plating. For the purpose of calculating the web thickness of frames, the required thickness of the shell plating is to be calculated according to [4.2.2] using the yield strength R_{eH} of the frames
- 9 mm.

Where there is a deck, top or bottom plating of a tank, tank-top or bulkhead in lieu of a frame, the plate thickness of it is to be calculated as above, to a depth corresponding to the

Ch 8, Sec 2, [2.2]

Replace requirements [2.2.1] and [2.2.2] by:

2.2.1 Upper end of transverse framing

The upper end of the strengthened part of a main ordinary stiffener and intermediate ice ordinary stiffener is to be attached to a deck, top or bottom plating of a tank or an ice stringer as required in [4.4.1].

1.3.3 Upper bow ice belt

The upper bow ice belt is the area extending from the upper limit of the ice belt to 2 m above and from the stem to a position at least 0,2 L aft of the forward perpendicular (see Fig 1).

at a stringer or a deck, a bracket or a similar construction is to be fitted. Brackets are to have at least the same thickness as the web plate of the ordinary stiffener and the edge is to be appropriately stiffened against buckling.

height of the adjacent frames. In such a case, the material properties of the deck, top or bottom plating of the tank, tank top or bulkhead and the frame height h_w of the adjacent frames are to be used in the calculations, and the constant C is to be taken equal to 805.

2.1.7 Within the ice-strengthened area defined in [1.3], asymmetrical frames and frames which are not at right angles to the shell (web less than 90 degrees to the shell) are to be supported against tripping by brackets, intercostals, stringers or similar, at a distance not exceeding 1300 mm.

For frames with spans greater than 4 m, the extent of anti-tripping supports is to be applied to all regions and for all ice classes.

For frames with spans less than or equal to 4 m, the extent of antitripping supports is to be applied to all regions for **ICE CLASS IA SUPER**, to the bow and midbody regions for **ICE CLASS IA**, and to the bow region for **ICE CLASS IB**, **ICE CLASS IC** and **ICE CLASS ID**.

Direct calculation methods may be applied to demonstrate the equivalent level of support provided by alternative arrangements.

Where an intermediate ordinary stiffener terminates above a deck or an ice stringer which is situated at or above the upper limit of the ice belt, the part above the deck or stringer is to have the scantlings required for a non-ices-strengthened ship. The upper end is to be connected to the adjacent main ordinary stiffeners by a horizontal member of the same scantlings as the main ordinary stiffener.

2.2.2 Lower end of transverse framing

The lower end of the strengthened part of a main ordinary stiffener and intermediate ice ordinary stiffener is to be attached to a deck, top or bottom plating of a tank, tank top or an ice stringer as required in [4.4.1].

Where an intermediate ordinary stiffener terminates below a deck, top or bottom plating of a tank, tank top or an ice stringer which is situated at or below the lower limit of the ice belt, the lower end is to be connected to the adjacent main ordinary stiffeners by a horizontal member of the same scantlings as the ordinary stiffeners.

Ch 8, Sec 2, [3.1.2]

Replace the first paragraph by:

The formulae and values given in this Section may be substituted by direct analysis if they are deemed by the Society to be invalid or inapplicable for a given structural arrange-

ment or detail. Otherwise, direct analysis is not to be used as an alternative to the analytical procedures prescribed by explicit requirements.

Replace “ h_o ” by “ h_i ” in the second paragraph.

Ch 8, Sec 2, [3.1]

Replace requirement [3.1.3] by:

3.1.3 If scantlings obtained from the requirements of this Section are less than those required for a ship that has not been ice strengthened, the latter are to be used.

Ch 8, Sec 2, [3.2.1]

Replace requirement [3.2.1] by:

3.2.1 Height of load area

The height of the area under ice pressure, h , at any particular point of time is to be obtained, in m, from Ch 8, Sec 1, Tab 2 depending on the additional class notation assigned to the ship.

Ch 8, Sec 2, [3.2.2]

Replace the definitions of “ P ” and “ c_p ” by:

P : Actual continuous output of propulsion machinery, in kW (see Ch 8, Sec 1, [3]) available when sailing in ice. If additional power sources are available for propulsion power (e.g. shaft motors) in addition to the power of the main engine(s), they shall also be included in the total engine output used as the basis for hull scant-

ling calculations. The engine output used for the calculation of the hull scantlings shall be clearly stated on the shell expansion drawing.

c_p : Factor that reflects the magnitude of the load expected in the hull area in question relative to the bow area, defined in Tab 6

Ch 8, Sec 2, [4.2.1]

Replace the bulleted list by:

- For the notation **ICE CLASS IA SUPER**, the fore foot region is to be ice-strengthened in the same way as the bow region
- For the notations **ICE CLASS IA SUPER** or **ICE CLASS IA**, on ships with an open water service speed equal to or exceeding 18 knots, the upper bow ice belt is to be ice-

strengthened in the same way as the midbody region. A similar strengthening of the bow region is to be considered for a ship with a lower service speed, when on the basis of the model tests, for example, it is evident that the ship will have a high bow wave.

Part F

Ch 8, Sec 2, [4.2.2]

Replace “ice strengthened area” by “ice belt” in the title.

Ch 8, Sec 2

Delete Table 3, Table 9, Table 11, Table 12 and Table 13.

Replace existing Table 6 by:

Table 6 : Coefficient c_p

Hull region	Notation						
	ICE CLASS IA SUPER	ICE CLASS IA	ICE CLASS IB	ICE CLASS IC	ICE CLASS ID	YOUNG ICE 1	YOUNG ICE 1
Bow	1,0	1,0	1,0	1,0	1,0	0,6	0,3
Midbody	1,0	0,85	0,70	0,50	not applicable		
Stern	0,75	0,65	0,45	0,25	not applicable		

Ch 8, Sec 2, [4.3.3]

Replace the definition of “ m_1 ” by:

m_1 : Boundary condition coefficient for the ordinary stiffener considered, to be taken equal to 13,3 for a continuous beam with brackets; where the boundary conditions deviate significantly from

those of a continuous beam with brackets, e.g. in an end field, a smaller boundary condition coefficient may be required.

Ch 8, Sec 2, [4.4.1] and [4.4.2]

Replace the definition of “ h ” by

h : Height, in m, of load area defined in [3.2.1], without the product ph being taken less than 0,15 MN/m.

Ch 8, Sec 2, [5.2.1]

Replace the term “ice strengthened area” by “ice belt”.

Ch 8, Sec 2, [5.3.1]

Replace “ h_0 ” by “ h_i ”.

Replace reference to “Tab 9” by a reference to “Ch 8, Sec 1, Tab 2”.

Ch 8, Sec 2, [5.3.2]

Replace the term “double bottom” by “tank top”.

Ch 8, Sec 2, [5.5.1]

Replace the term “ice strengthened area” by “ice belt”.

Ch 8, Sec 2, [6.2.1]

Replace two terms “ice strengthened area” by “ice belt”.

Ch 8, Sec 2, [7.1]

Replace requirement [7.1.2] by:

7.1.2 Vertical extension

The vertical extension of the ice strengthened area is defined in Tab 1 for plating (ice belt) and in Tab 2 for ordinary stiffeners and primary supporting members.

Ch 8, Sec 2, [7.2.1]

Replace “ h_0 ” by “ h_i ” in the first and third paragraph.

Replace reference to “Tab 12” by a reference to “Ch 8, Sec 1, Tab 2”.

Ch 8, Sec 2, [7.2]

Replace requirement [7.2.2] by:

7.2.2 Ice loads

The design ice pressure p , in N/mm², is to be calculated according to [3.2], with the nominal ice pressure, p_0 , to be taken equal to 3,0.

Ch 8, Sec 2, [7.3.2]

Replace “ice strengthened area” by “ice belt” in the title.

Ch 8, Sec 2, [7.5.1]

Replace “ice strengthened area” by “ice belt”.

Ch 8, Sec 3, Symbols

Delete the definitions of “ h_0 ”, “ $P_{0,7b}$ ”, “ γ_ε ”.

Insert the definitions of “ Q_{max}^n ”, “ Q_{peak} ”, “ Q_{sex} ”, “ Q_{vib} ”, “ φ ”, “ α_1 ”, “ α_2 ”, “ $\gamma_{\varepsilon 1}$ ”, “ $\gamma_{\varepsilon 2}$ ”.

Replace the definition of “ I ” by “ I_e ”:

Replace the definitions of “ F_b ”, “ F_f ”, “ $(F_{ice})_{max}$ ”, “ H_{ice} ”, “ n ”, “ n_n ”, “ N_{class} ”, “ N_{ice} ”, “ $P_{0,7}$ ”, “ $P_{0,7n}$ ”, “ Q_{emax} ”, “ Q_n ”, “ Q_{smax} ”, “ T_b ”, “ T_f ”, “ T_n ”, “ $\sigma_{0,2}$ ”, “ σ_u ”:

F_b	: Maximum backward blade force during the ship's service life, in kN. See Tab 1	I_e	: Equivalent mass moment of inertia of all parts on engine side of the component under consideration, in kg·m ²
F_f	: Maximum forward blade force during the ship's service life, in kN. See Tab 1	n	: Rotational propeller speed in bollard condition, in rev/s. If not known, n is to be taken equal to the values given in Tab 7
$(F_{ice})_{max}$: Maximum ice load during the ship's service life, in kN	n_n	: Nominal rotational propeller speed at MCR in free running open water condition, in rev/s
H_{ice}	: Thickness of maximum design ice block entering the propeller, in m		

Part F

N_{class}	: Reference number of impacts per nominal propeller rotational speed per ice class	Q_{vib}	: Vibratory torque at considered component, taken from frequency domain open water torque vibration calculation (TVC), in kN·m
N_{ice}	: Total number of ice loads on propeller blade during the ship's service life	T_{b}	: Maximum backward propeller ice thrust during the ship's service life, in kN. See Tab 1
$P_{0,7}$: Propeller pitch at 0,7 R radius, in m. If not known, $P_{0,7}$ is to be taken equal to 0,7 $P_{0,7n}$	T_{f}	: Maximum forward propeller ice thrust during the ship's service life, in kN. See Tab 1
$P_{0,7n}$: Propeller pitch at 0,7 R radius at MCR in free running open water condition, in m	T_{n}	: Nominal propeller thrust at MCR in free running open water condition, in kN
Q_{emax}	: Maximum engine torque, in kN·m. If not known, Q_{emax} is to be taken equal to the values given in Tab 9	φ	: Rotation angle, in deg, from when the first impact occurs.
Q_{max}^n	: Maximum torque on the propeller resulting from propeller/ice interaction reduced to the rotational speed in question, in kN·m	α_1	: Phase angle of propeller ice torque for blade order excitation component, in degrees
Q_{n}	: Nominal torque at MCR in free running open water condition, in kN·m	α_2	: Phase angle of propeller ice torque for twice the blade order excitation component, in degrees
Q_{peak}	: Maximum of the response torque Q_{f} , in kN·m	γ_{e1}	: Reduction factor for fatigue; scatter effect (equal to one standard deviation)
Q_{smax}	: Maximum spindle torque of the blade during the ship's service life, in kN·m. See Tab 1	γ_{e2}	: Reduction factor for fatigue; test specimen size effect
Q_{sex}	: Maximum spindle torque due to blade failure caused by plastic bending, in kN·m.	$\sigma_{0,2}$: Minimum yield or 0,2% proof strength of blade material, in MPa, to be specified on the drawing.
		σ_{u}	: Ultimate tensile strength of blade material, in MPa, to be specified on the drawing.

Ch 8, Sec 3, [1.1]

Replace requirement [1.1.1] by:

1.1.1 These regulations apply to propulsion machinery covering open- and ducted-type propellers with controllable pitch or fixed pitch design for the class notations **ICE CLASS IA SUPER**, **ICE CLASS IA**, **ICE CLASS IB** and **ICE CLASS IC**.

The given loads are the expected ice loads for the whole ship's service life under normal operational conditions, including loads resulting from the changing rotational direction of FP propellers.

However, these loads do not cover off-design operational conditions, for example when a stopped propeller is dragged through ice.

The regulations also apply to azimuthing and fixed thrusters for main propulsion, considering loads resulting from pro-

PELLER-ICE interaction and loads on the thruster body/ice interaction.

The given azimuthing thruster body loads are the expected ice loads during the ship's service life under normal operational conditions. The local strength of the thruster body shall be sufficient to withstand local ice pressure when the thruster body is designed for extreme loads.

However, the load models of the regulations do not include propeller/ice interaction loads when ice enters the propeller of a turned azimuthing thruster from the side (radially)

The thruster global vibrations caused by blade order excitation on the propeller may cause significant vibratory loads.

Ch 8, Sec 3, [1.3]

Replace requirements [1.3.1] and [1.3.2] by:

1.3.1 Materials exposed to sea water

Materials of components exposed to sea water, such as propeller blades, blade bolts, propeller hubs, and thruster body, are to have an elongation of not less than 15% on a test specimen, the gauge length of which is five times the diameter. A Charpy V impact test is to be carried out for materials other than bronze and austenitic steel. An average impact energy value of 20 J taken from three tests is to be obtained at minus 10°C. For nodular cast iron, average impact energy of 10 J at minus 10°C is required accordingly.

1.3.2 Materials exposed to sea water temperature

Materials exposed to sea water temperature shall be of ductile material. An average impact energy value of 20 J taken from three tests is to be obtained at minus 10°C. This requirement applies to the propeller shaft, CP mechanisms, shaft bolts, strut-pod connecting bolts etc. This does not apply to surface hardened components, such as bearings and gear teeth. The nodular cast iron of a ferrite structure type may be used for relevant parts other than bolts. The average impact energy for nodular cast iron is to be a minimum of 10 J at minus 10°C.

Ch 8, Sec 3

Replace Table 1, Table 4 and Table 5 as follows:

Table 1 : Definition of loads

	Definition	Use of the load in design process
F_b	The maximum lifetime backward force on a propeller blade resulting from propeller/ice interaction, including hydrodynamic loads on that blade. The direction of the force is perpendicular to 0.7R chord line. See Fig 1	Design force for strength calculation of the propeller blade
F_f	The maximum lifetime forward force on a propeller blade resulting from propeller/ice interaction, including hydrodynamic loads on that blade. The direction of the force is perpendicular to 0,7R chord line	Design force for strength calculation of the propeller blade
Q_{smax}	The maximum lifetime spindle torque on a propeller blade resulting from propeller/ice interaction, including hydrodynamic loads on that blade	When designing the propeller strength, the spindle torque is automatically taken into account because the propeller load is acting on the blade as distributed pressure on the leading edge or tip area
T_b	The maximum lifetime thrust on propeller (all blades) resulting from propeller/ice interaction. The direction of the thrust is the propeller shaft direction and the force is opposite to the hydrodynamic thrust	Is used for estimating of the response thrust T_r . T_b can be used as an estimate of excitation in axial vibration calculations. However, axial vibration calculations are not required by the rules
T_f	The maximum lifetime thrust on propeller (all blades) resulting from propeller/ice interaction. The direction of the thrust is the propeller shaft direction acting in the direction of hydrodynamic thrust	Is used for estimating of the response thrust T_r . T_f can be used as an estimate of excitation in axial vibration calculations. However, axial vibration calculations are not required by the rules
Q_{max}	The maximum ice-induced torque resulting from propeller/ice interaction on one propeller blade, including hydrodynamic loads on that blade	Is used for estimating of the response torque (Q_r) along the propulsion shaft line and as excitation for torsional vibration calculations
F_{ex}	Ultimate blade load resulting from blade loss through plastic bending. The force that is needed to cause total failure of the blade so that plastic hinge appear in the root area. The force is acting on 0,8R. The spindle arm is 2/3 of the distance between the axis of blade rotation and leading/trailing edge (whichever is the greater) at the 0,8R radius	Blade failure load is used to dimension the blade bolts, pitch control mechanism, propeller shaft, propeller shaft bearing and trust bearing. The objective is to guarantee that total propeller blade failure does not lead to damage to other components
Q_r	Maximum response torque along the propeller shaft line, taking into account the dynamic behavior of the shaft line for ice excitation (torsional vibration) and hydrodynamic mean torque on propeller	Design torque for propeller shaft line components
T_r	Maximum response thrust along shaft line, taking into account the dynamic behavior of the shaft line for ice excitation (axial vibration) and hydrodynamic mean thrust on propeller	Design thrust for propeller shaft line components
F_{ti}	Maximum response force caused by ice block impacts on the thruster body or the propeller hub	Design load for thruster body and slewing bearings.
F_{tr}	Maximum response force on the thruster body caused by ice ridge/thruster body interaction	Design load for thruster body and slewing bearings

Table 4 : Load cases for open propellers

	Force	Loaded Area	Right-handed propeller blade seen from behind
Load Case 1	F_b	Uniform pressure applied on the blade back (suction side) to an area from 0,6R to the tip and from the leading edge to 0,2 times the chord length	
Load Case 2	50% of F_b	Uniform pressure applied on the blade back (suction side) of the blade tip area outside 0,9R radius	
Load Case 3	F_f	Uniform pressure applied on the blade face (pressure side) to an area from 0,6R to the tip and from the leading edge to 0,2 times the chord length	
Load Case 4	50% of F_f	Uniform pressure applied on the blade face (pressure side) of the blade tip area outside 0,9R radius	
Load Case 5	60% of F_f or 60% of F_b , whichever is greater	Uniform pressure applied on the blade face (pressure side) to an area from 0,6R to the tip and from the trailing edge to 0,2 times the chord length	

Table 5 : Load cases for ducted propellers

	Force	Loaded Area	Right-handed propeller blade seen from behind
Load Case 1	F_b	Uniform pressure applied on the blade back (suction side) to an area from $0,6R$ to the tip and from the leading edge to $0,2$ times the chord length	
Load Case 3	F_f	Uniform pressure applied on the blade face (pressure side) to an area from $0,6R$ to the tip and from the leading edge to $0,5$ times the chord length	
Load Case 5	60% of F_f or 60% of F_b , whichever is greater	Uniform pressure applied on the blade face (pressure side) to an area from $0,6R$ to the tip and from the trailing edge to $0,2$ times the chord length	

Ch 8, Sec 3, [1.4]

Replace requirements [1.4.1] by:

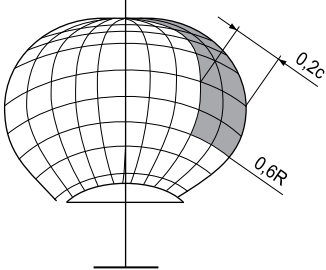
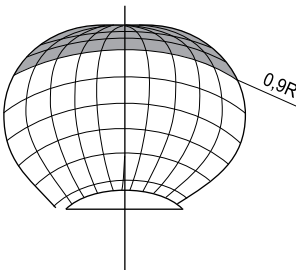
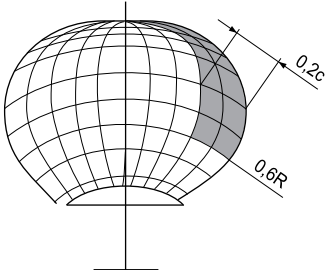
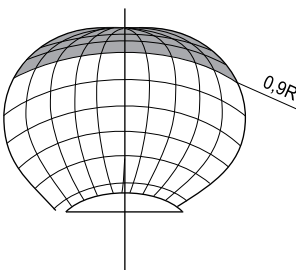
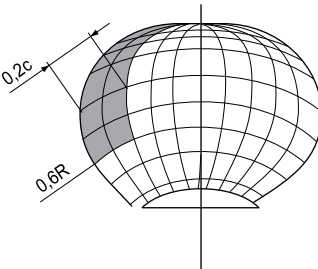
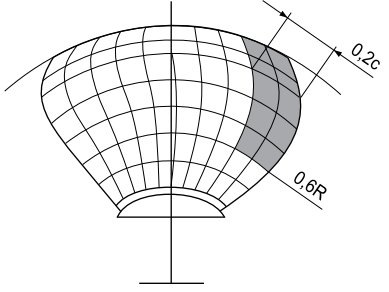
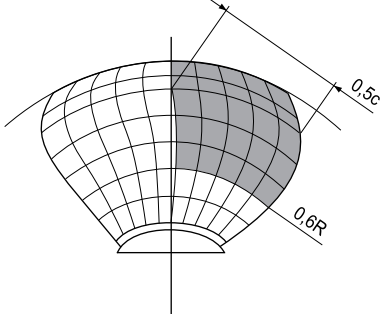
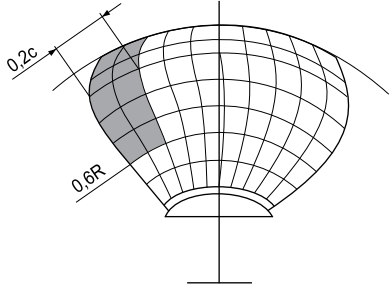
1.4.1 The given loads are intended for component strength calculations only and are total loads including ice-induced loads and hydrodynamic loads during propeller/ice interaction. The presented maximum loads are based on a worst case scenario that occurs once during the service life of the ship. Thus, the load level for a higher number of loads is lower. The values of the parameters in the formulae in this

section shall be given in the units shown in the symbol list. If the highest point of the propeller is not at a depth of at least h ; below the water surface when the ship is in ballast condition, the propulsion system shall be designed according to ice class **ICE CLASS IA** for ice classes **ICE CLASS IB** and **ICE CLASS IC**.

Ch 8, Sec 3, [1.4.2]

Delete the definition of "n" in items a) and d).

Delete the definition of " $c_{0,7}$ " in item g).

Part F

Replace the second paragraph in item g) by:

The spindle torque Q_{smax} around the axis of the blade fitting shall be determined both for the maximum backward blade force F_b and forward blade force F_f , which are applied as in Tab 4 and Tab 5. The larger of the obtained torques is used

Replace the definition of “ N_{ice} ” in item h) by:

N_{ice} : Number of load cycles in the load spectrum (see item i))

Replace the definition of “ k_3 ” in item i) by:

- k_3 : Propulsion type factor:
- for a fixed propulsor: $k_3 = 1,0$
 - for an azimuthing propulsor: $k_3 = 1,2$

Ch 8, Sec 3, Table 6

Delete the definition of “ T_n ” in the table foot..

Ch 8, Sec 3, [1.4]

Replace requirements [1.4.4] and [1.4.5] by:

1.4.4 Torsional design loads

a) Design ice torque on propeller Q_{max} for open propellers:

- when $D \leq D_{limit}$

$$Q_{max} = 10,9 \left(1 - \frac{d}{D}\right) \left(\frac{P_{0,7}}{D}\right)^{0,16} (nD)^{0,17} D^3$$

- when $D > D_{limit}$

$$Q_{max} = 20,7 \left(1 - \frac{d}{D}\right) \left(\frac{P_{0,7}}{D}\right)^{0,16} (nD)^{0,17} D^{1,9} H_{ice}^{1,1}$$

where:

$$D_{limit} = 1,8 H_{ice}$$

b) Design ice torque on propeller Q_{max} for ducted propellers:

- when $D \leq D_{limit}$

$$Q_{max} = 7,7 \left(1 - \frac{d}{D}\right) \left(\frac{P_{0,7}}{D}\right)^{0,16} (nD)^{0,17} D^3$$

- when $D > D_{limit}$

$$Q_{max} = 14,6 \left(1 - \frac{d}{D}\right) \left(\frac{P_{0,7}}{D}\right)^{0,16} (nD)^{0,17} D^{1,9} H_{ice}^{1,1}$$

where:

$$D_{limit} = 1,8 H_{ice}$$

c) Design torque for non-resonant shaft line:

When there is not any relevant first blade order torsional resonance in the operational speed range or in range 20% above and 20% below the maximum operating speed (bollard condition), the following estimation of the maximum torque is to be used:

- for directly coupled two stroke diesel engines without flexible coupling:

$$Q_{peak} = Q_{emax} + Q_{vib} + Q_{max} \frac{I_e}{I_t}$$

as the dimensioning torque. If the above method gives a value which is less than the default value given by the formula below, the default value shall be used:

- for other plants :

$$Q_{peak} = Q_{emax} + Q_{max} \frac{I_e}{I_t}$$

All the torques and the inertia moments are to be reduced to the rotation speed of the component being examined.

d) Design torque for shaft lines having resonances:

When there is a first blade order torsional resonance in the operational speed range or in the range 20% above and 20% below the maximum operating speed (bollard condition), the design torque (Q_{peak}) of the shaft component is to be determined by means of torsional vibration analysis of the propulsion line. There are two alternative ways of performing the dynamic analysis:

- time domain calculation for estimated milling sequence excitation (see item e)
- frequency domain calculation for blade orders sinusoidal excitation (see item f)

The frequency domain analysis is generally considered conservative compared to the time domain simulation, provided that there is a first blade order resonance in the considered speed range.

e) Time domain calculation of torsional response:

Time domain calculations are to be calculated for the MCR condition, MCR bollard conditions and for blade order resonant rotational speeds so that the resonant vibration responses can be obtained.

The load sequence given in this chapter, for a case where a propeller is milling an ice block, is to be used for the strength evaluation of the propulsion line. The given load sequence is not intended for propulsion system stalling analyses.

The following load cases are intended to reflect the operational loads on the propulsion system, when the propeller interacts with ice, and the respective reaction of the complete system. The ice impact and system response causes loads in the individual shaft line components. The ice torque Q_{\max} is to be taken as a constant value in the complete speed range. When considerations at specific shaft speeds are performed, a relevant Q_{\max} is to be calculated using the relevant speed according to item a) or item b).

Diesel engine plants without an elastic coupling are to be calculated at the least favourable phase angle for ice versus engine excitation, when calculated in the time domain. The engine firing pulses is to be included in the calculations and their standard steady state harmonics can be used.

When there is a blade order resonance just above the MCR speed, calculations are to cover rotational speeds up to 105% of the MCR speed.

The propeller ice torque excitation for shaft line transient dynamic analysis in the time domain is defined as a sequence of blade impacts which are of half sine shape. The excitation frequency shall follow the propeller rotational speed during the ice interaction sequence. The torque due to a single blade ice impact as a function of the propeller rotation angle is then defined using the formula:

- when $\varphi = 0, \dots, \alpha_i$ plus integer revolutions:

$$Q(\varphi) = C_q Q_{\max} \sin [\varphi (180/\alpha_i)]$$
- when $\varphi = \alpha_i, \dots, 360^\circ$ plus integer revolutions:

$$Q(\varphi) = 0$$

where:

- α_i : Duration of propeller blade/ice interaction given in Tab 8 and represented in Fig A.
- C_q : Ice impact magnification parameter given in Tab 8.

The total ice torque is obtained by summing the torque of single blades, while taking into account of the phase shift $360^\circ/Z$ (see Fig B and Fig C). At the beginning and end of the milling sequence (within the calculated duration) linear ramp functions are to be used to increase C_q to its maximum value within one propeller revolution and vice versa to decrease it to zero (see examples of different Z numbers in Fig B and Fig C).

The number of propeller revolutions during a milling sequence are to be obtained with the formula:

$$N_Q = 2 H_{\text{ice}}$$

The number of impacts is $Z \cdot N_Q$ for blade order excitation.

A dynamic simulation is to be performed for all excitation cases at the operational rotational speed range. For a fixed pitch propeller propulsion plant, a dynamic simulation must also cover the bollard pull condition with a corresponding rotational speed assuming the maximum possible output of the engine.

When a speed drop occurs until the main engine is at a standstill, this indicates that the engine may not be sufficiently powered for the intended service task. For the consideration of loads, the maximum occurring torque during the speed drop process must be used.

For the time domain calculation, the simulated response torque typically includes the engine mean torque and the propeller mean torque. When this is not the case, the response torques must be obtained using the formula:

$$Q_{\text{peak}} = Q_{\text{emax}} + Q_{\text{rtid}}$$

where Q_{rtid} is the maximum simulated torque obtained from the time domain analysis.

- f) Frequency domain calculation of torsional response:

For frequency domain calculations, blade order and twice-the-blade-order excitation are to be used. The amplitudes for the blade order and twice-the-blade-order sinusoidal excitation have been derived based on the assumption that the time domain half sine impact sequences were continuous, and the Fourier series components for blade order and twice-the-blade-order components have been derived. With these assumptions, the propeller ice torque $Q_F(\varphi)$, in kN·m, is equal to:

$$Q_{\max} [C_{q0} + C_{q1} \sin(ZE_0\varphi + \alpha_1) + C_{q2} \sin(2ZE_0\varphi + \alpha_2)]$$

where:

- C_{q0} : Mean torque parameter, see Tab F
- C_{q1} : First blade order excitation parameter, see Tab F
- C_{q2} : Second blade order excitation parameter, see Tab F
- E_0 : Number of ice blocks in contact, see Tab F.

The design torque for the frequency domain excitation case is to be obtained using the formula:

$$Q_{\text{peak}} = Q_{\text{emax}} + Q_{\text{vib}} + (Q_{\max}^n C_{q0})_{I_1}^{I_e} + Q_{\text{rf1}} + Q_{\text{rf2}}$$

where:

- C_{rf1} : First blade order torsional response from the frequency domain analysis
- C_{rf2} : Second blade order torsional response from the frequency domain analysis.

All the torque values have to be scaled to the shaft revolutions for the component in question.

- g) Guidance for torsional vibration calculation:

The aim of time domain torsional vibration simulations is to estimate the extreme torsional load during the ship's service life. The simulation model can be taken from the normal lumped mass elastic torsional vibration model, including damping.

For a time domain analysis, the model should include the ice excitation at the propeller, other relevant excitations and the mean torques provided by the prime mover and hydrodynamic mean torque in the propeller.

The calculations should cover variation of phase between the ice excitation and prime mover excitation.

Part F

This is extremely relevant to propulsion lines with directly driven combustion engines. Time domain calculations shall be calculated for the MCR condition, MCR bollard conditions and for resonant speed, so that the resonant vibration responses can be obtained.

For frequency domain calculations, the load should be estimated as a Fourier component analysis of the continuous sequence of half sine load sequences. First and second order blade components should be used for excitation.

The calculation should cover the entire relevant rpm range and the simulation of responses at torsional vibration resonances.

1.4.5 Blade failure load

a) Bending force, F_{ex}

The ultimate load resulting from blade failure as a result of plastic bending around the blade root is to be calculated with the formula as follows:

$$F_{ex} = \frac{300ct^2\sigma_{refl}}{0,8D - 2r}$$

where:

c, t, r : Actual chord length, maximum thickness and radius, respectively, of the cylindrical root section of the blade which is the weakest section outside the root fillet typically located at the point where the fillet terminates at the blade profile.

The ultimate load may be obtained alternatively by means of an appropriate stress analysis reflecting the non-linear plastic material behaviour of the actual blade. In such a case, the blade failure area may be outside the root section. The ultimate load is assumed to be

acting on the blade at the 0,8R radius in the weakest direction of the blade. A blade is regarded as having failed if the tip is bent into an offset position by more than 10% of propeller diameter D.

b) Spindle torque, Q_{sex}

The maximum spindle torque due to a blade failure load acting at 0,8R is to be determined. The force that causes blade failure typically reduces when moving from the propeller centre towards the leading and trailing edges. At a certain distance from the blade centre of rotation, the maximum spindle torque will occur (Fig D illustrates the spindle torque values due to blade failure loads across the entire chord length). This maximum spindle torque shall be defined by an appropriate stress analysis or using the equation given below:

$$Q_{sex} = C_{LTx} C_{spex} F_{ex}$$

where:

C_{LTx} : Coefficient to be taken equal to:

$$C_{LTx} = \max(C_{LE0,8}; 0,8C_{TE0,8})$$

C_{spex} : Coefficient to be taken equal to:

$$C_{spex} = C_{sp} C_{fex} = 0,7 \left(1 - \left(\frac{4EAR}{Z} \right)^3 \right)$$

without being taken less than 0,3

C_{sp} : Parameter taking account of the spindle arm

C_{fex} : Parameter taking account of the reduction of the blade failure force at the location of the maximum spindle torque

$C_{LE0,8}$: Leading edge portion of the chord length at 0,8R

$C_{TE0,8}$: Trailing edge portion of the chord length at 0,8R

Ch 8, Sec 3, Table 7 and Table 9

Delete Note 1 in the two tables.

Replace the table titles as follows:

Table 7 : Rotational propeller speed n , at MCR in bollard condition

Table 9 : Default prime mover maximum torque Q_{emax}

Ch 8, Sec 3, [1.5.1]

Replace the definition of " M_{BL} " by:

M_{BL} : For relative radius $r/R < 0,5$:

$$M_{BL} = (0,75 - r/R) R \cdot F$$

where F is the maximum of F_b and F_f , which ever has greater absolute value.

Ch 8, Sec 3

Delete Figure 3, Figure 4 and Figure 5.

Insert the following Figure A, Figure B, Figure C, and Figure D:

Figure A : Schematic ice torque due to a single blade ice impact

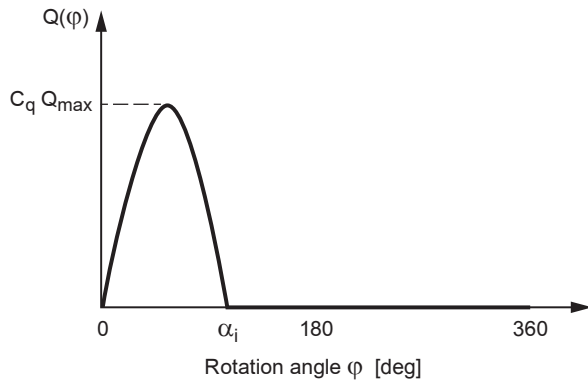

Figure C : Propeller ice torque excitation for 5 and 6 blades

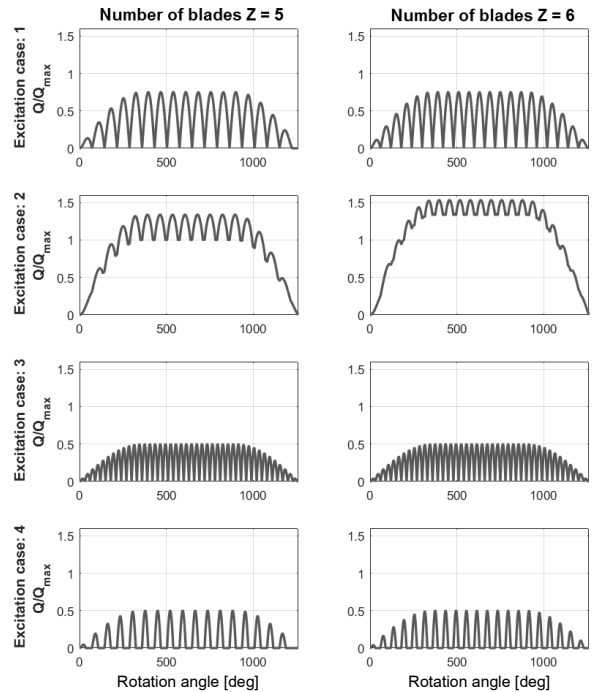

Figure B : Propeller ice torque excitation for 3 and 4 blades

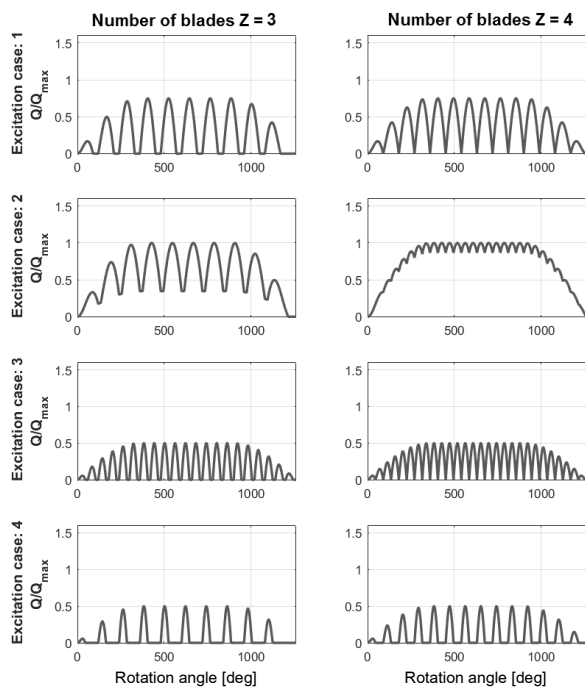
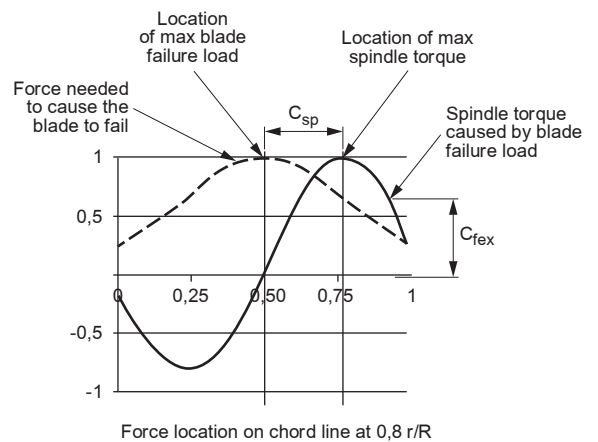

Figure D : Blade failure load and related spindle torque along chord line at radius 0,8R



Ch 8, Sec 3

Replace Table 8, Table 10 and Table 11 and insert the following Table F:

Table 8 : Parameters C_q and α_i

Torque excitation	Propeller/ice interaction	C_q	α_i			
			Z = 3	Z = 4	Z = 5	Z = 6
Case 1	Single ice block	0,75	90	90	72	60
Case 2	Single ice block	1,0	135	135	135	135
Case 3	Two ice blocks (phase shift 360/2Z deg.)	0,5	45	45	36	30
Case 4	Single ice block	0,5	45	45	36	30

Table 10 : Coefficients C_1 , C_2 , C_3 and C_4

	Open propeller	Ducted propeller
C_1	0,000747	0,000534
C_2	0,0645	0,0533
C_3	- 0,0565	- 0,0459
C_4	2,22	2,584

Table 11 : Values for the G parameter for different m/k ratios

m/k	G	m/k	G	m/k	G
3,0	6,0	6,0	720,0	9,0	362880
3,5	11,6	6,5	1871	9,5	1,133·10 ⁶
4,0	24,0	7,0	5040	10	3,626·10 ⁶
4,5	52,3	7,5	14034	10,5	11,899·10 ⁶
5,0	120	8,0	40320	11	39,917·10 ⁶
5,5	287,9	8,5	119292	11,5	136,843·10 ⁶
				12	479,002·10 ⁶

Table F : Coefficients for frequency domain excitation calculation (Z)

	Torque excitation	C_{q0}	C_{q1}	α_1	C_{q2}	α_2	E_0
Z = 3	Case 1	0,375	0,36	-90	0	0	1
	Case 2	0,7	0,33	-90	0,05	-45	1
	Case 3	0,25	0,25	-90	0	0	2
	Case 4	0,2	0,25	0	0,05	-90	1

Z = 4	Case 1	0,45	0,36	-90	0,06	-90	1
	Case 2	0,9375	0	-90	0,0625	-90	1
	Case 3	0,25	0,25	-90	0	0	2
	Case 4	0,2	0,25	0	0,05	-90	1

Z = 5	Case 1	0,45	0,36	-90	0,06	-90	1
	Case 2	1,19	0,17	-90	0,02	-90	1
	Case 3	0,3	0,25	-90	0,048	-90	2
	Case 4	0,2	0,25	0	0,05	-90	1

Z = 6	Case 1	0,45	0,36	-90	0,05	-90	1
	Case 2	1,435	0,1	-90	0	0	1
	Case 3	0,30	0,25	-90	0,048	-90	2
	Case 4	0,2	0,25	0	0,05	-90	1

Ch 8, Sec 3, [1.5]

Replace requirements [1.5.2] and [1.5.3] as follows:

1.5.2 Acceptability criterion

The following criterion for calculated blade stresses is to be fulfilled:

$$\frac{\sigma_{ref2}}{\sigma_{st}} \geq 1,3$$

where:

σ_{st} : Calculated stress for the design loads.

If FEM analysis is used in estimating the stresses, von Mises stresses are to be used.

1.5.3 Fatigue design of propeller blade

The fatigue design of the propeller blade is based on an estimated load distribution during the service life of the ship and on the S-N curve for the blade material. An equivalent stress that produces the same fatigue damage as the expected load distribution is to be calculated and the acceptability criterion for fatigue is to be fulfilled as given in [1.5.4]. The equivalent stress is normalised for 10^8 cycles.

For materials with a two-slope SN curve (see Fig 6), fatigue calculations in accordance with this chapter are not required if the following criterion is fulfilled:

$$\sigma_{exp} \geq B_1 \cdot \sigma_{ref2}^{B_2} \cdot \log(N_{ice})^{B_3}$$

where:

B_1, B_2, B_3 : Coefficients for open and ducted propellers:

- for open propellers:
 - $B_1 = 0,00246$
 - $B_2 = 0,947$
 - $B_3 = 2,101$
- for ducted propellers:
 - $B_1 = 0,00167$
 - $B_2 = 0,956$
 - $B_3 = 2,470$

For calculation of equivalent stress, two types of S-N curves are available:

- two-slope S-N curve (slopes 4,5 and 10), see Fig 6
- constant-slope S-N curve (the slope can be chosen), see Fig 7.

The type of the S-N curve is to be selected to correspond to the material properties of the blade. If the S-N curve is not known, the two-slope S-N curve is to be used.

a) Equivalent fatigue stress

The equivalent fatigue stress σ_{fat} for 10^8 stress cycles, which produces the same fatigue damage as the load distribution, is given by the following formula:

$$\sigma_{fat} = \rho (\sigma_{ice})_{max}$$

where:

$(\sigma_{ice})_{max}$: Mean value of the principal stress amplitudes resulting from design forward and backward blade forces at the location being studied and defined by:

$$(\sigma_{ice})_{max} = 0,5 [(\sigma_{ice})_{f max} - (\sigma_{ice})_{b max}]$$

$(\sigma_{ice})_{f max}$: Principal stress resulting from forward load

$(\sigma_{ice})_{b max}$: Principal stress resulting from backward load.

In calculation of $(\sigma_{ice})_{max}$, case 1 and case 3 (or case 2 and case 4) are considered as a pair for $(\sigma_{ice})_{f max}$ and $(\sigma_{ice})_{b max}$ calculations. Case 5 is excluded from the fatigue analysis.

b) Calculation of parameter ρ for two-slope S-N curve

The parameter ρ relates the maximum ice load to the distribution of ice loads according to the regression formula:

$$\rho = C_1 \cdot (\sigma_{ice})_{max}^{C_2} \cdot \sigma_{fl}^{C_3} \cdot \log(N_{ice})^{C_4}$$

where:

C_1, C_2, C_3, C_4 : Coefficients given in Tab 10

$$\sigma_{fl} = \gamma_{\epsilon 1} \cdot \gamma_{\epsilon 2} \cdot \gamma_v \cdot \gamma_m \cdot \sigma_{exp1}$$

with:

γ_v : Reduction factor for variable amplitude loading

γ_m : Reduction factor for mean stress.

The following values may be used for the reduction factors if the actual values are not available:

$$\gamma_{\epsilon 1} \cdot \gamma_{\epsilon 2} = 0,67$$

$$\gamma_v = 0,75$$

$$\gamma_m = 0,75$$

c) Calculation of parameter ρ for constant-slope S-N curve

For materials with a constant-slope S-N curve (see Fig 7), parameter ρ is to be calculated from the following formula:

$$\rho = \left(G \frac{N_{ice}}{N_R} \right)^{\frac{1}{m}} [\ln(N_{ice})]^{-\frac{1}{k}}$$

where:

k : Shape parameter of the Weibull distribution:

- for ducted propellers: $k = 1,0$
- for open propellers: $k = 0,75$

N_{ice} : Value to be taken between $5 \cdot 10^6$ and 10^8

G : Parameter defined in Tab 11. Linear interpolation may be used to calculate the value of G for other m/k ratios than those given in Tab 11.

Ch 8, Sec 3, [1.7.1]

Replace the second paragraph by:

The shafts and shafting components, such as the thrust and stem tube bearings, couplings, flanges and sealings, are to be designed to withstand the propeller/ice interaction loads as given in [1.4]. The safety factor is to be at least 1,3

against yielding for extreme operational loads, 1,5 for fatigue loads and 1,0 against yielding for the blade failure load.

Ch 8, Sec 3, [1]

Replace sub-articles [1.11] and [1.12] by the following sub article [1.11]:

1.11 Azimuthing main propulsors

1.11.1 Design principles

In addition to the above requirements for propeller blade dimensioning, azimuthing thrusters have to be designed for thruster body/ice interaction loads.

Load formulae are given for estimating once in a lifetime extreme loads on the thruster body, based on the estimated ice condition and ship operational parameters. Two main ice load scenarios have been selected for defining the extreme ice loads. Examples of loads are illustrated in Fig 9. In addition, blade order thruster body vibration responses may be estimated for propeller excitation. The following load scenario types are considered:

- a) Ice block impact to the thruster body or propeller hub
- b) Thruster penetration into an ice ridge that has a thick consolidated layer
- c) Vibratory response of the thruster at blade order frequency.

The steering mechanism, the fitting of the unit, and the body of the thruster are to be designed to withstand the plastic bending of a blade without damage. The loss of a blade must be taken into account for the propeller blade orientation causing the maximum load on the component being studied. Top-down blade orientation typically places the maximum bending loads on the thruster body.

1.11.2 Extreme ice impact loads

When the ship is operated in ice conditions, ice blocks formed in channel side walls or from the ridge consolidated layer may impact on the thruster body and also on the propeller hub. Exposure to ice impact is very much dependent on the ship size and ship hull design, as well as location of the thruster. The contact force will grow in terms of thruster/ice contact until the ice block reaches the ship speed.

The thruster has to withstand the loads occurring when the design ice block defined in Tab 3 impacts on the thruster body when the ship is sailing at a typical ice operating speed. Load cases for impact loads are given in Tab 9. The contact geometry is estimated to be hemispherical in shape. If the actual contact geometry differs from the shape of the hemisphere, a sphere radius has to be estimated so that the growth of the contact area as a function of penetration of ice corresponds as closely as possible to the actual geometrical shape penetration.

The ice impact contact load F_{ti} , in kN, is to be calculated as follows:

$$F_{ti} = C_{DMI} 34.5 R_C^{0.5} (m_{ice} v_s^2)^{0.333}$$

where:

- R_C : Impacting part sphere radius, in m, as shown in Fig 10
- m_{ice} : Ice block mass, in kg, as given in Tab 13
- C_{DMI} : Dynamic magnification factor for impact loads. If unknown, C_{DMI} may to be taken from Tab 13
- v_s : Impact speed, in m/s, as defined in Tab 14 or Tab 15. On a case by case basis, v_s can also be derived from the ship actual design operation speed in ice, subject to the Society agreement.

For impacts on non-hemispherical areas, such as the impact on the nozzle, R_C is to be replaced by the equivalent impact sphere radius R_{ceq} , in m, to be estimated using the equation below:

$$R_{ceq} = \sqrt{\frac{A}{\pi}}$$

where:

- A : Contact area, in m^2 , as shown in Tab 12.

Figure 9 : Examples of load scenario types

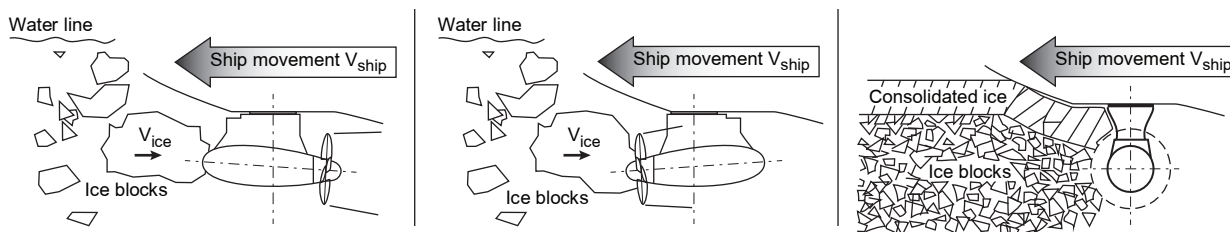

Table 12 : Load cases for azimuthing thruster impact loads

Load Case	Force	Loaded area	Loaded area
Load case T1a Symmetric longitudinal ice impact on thruster	F_{ti}	Uniform pressure applied symmetrically on the impact area	
Load case T1b Non-symmetric longitudinal ice impact on thruster	50% of F_{ti}	Uniform pressure applied on the other half of the impact area	
Load case T1c Non-symmetric longitudinal ice impact on nozzle	F_{ti}	Uniform pressure applied on the impact area. Contact area is equal to the nozzle thickness (H_{nz})* contact height (H_{ice})	
Load case T2a Symmetric longitudinal ice impact on propeller hub	F_{ti}	Uniform pressure applied symmetrically on the impact area	
Load case T2b Non-symmetric longitudinal ice impact on propeller hub	50% of F_{ti}	Uniform pressure applied on the other half of the impact area	
Load case T3a Symmetric lateral ice impact on thruster body	F_{ti}	Uniform pressure applied symmetrically on the impact area	

Part F

Load Case	Force	Loaded area	
Load case T3b Non-symmetric lateral ice impact on thruster body or nozzle	F_{ii}	Uniform pressure applied on the other half of the impact area. Nozzle contact radius R to be taken from the nozzle length	

Note 1: For fixed thrusters, only the relevant load cases are to be considered.

If the $2 \cdot R_{ceq}$ is greater than the ice block thickness given in Tab 3, the radius is set to half of the ice block thickness.

For impact on the thruster side, the pod body diameter can be used as basis for determining the radius. For impact on the propeller hub, the hub diameter can be used as basis for the radius.

The longitudinal impact speed in Tab 14 and Tab 15 refers to the impact in the thruster's main operational direction. For the pulling propeller configuration, the longitudinal impact speed is used for load case T2, impact on hub; and for the pushing propeller unit, the longitudinal impact speed is used for load case T1, impact on thruster end cap. For the opposite direction, the impact speed for transversal impact is applied.

Figure 10 : Dimensions used for R_c

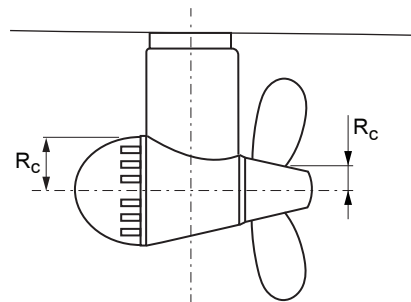

Table 13 : Parameter values for ice dimensions and dynamic magnification

Notation	IA Super	IA	IB	IC
Thickness of the design ice block impacting thruster ($2/3$ of H_{ice}) (m)	1,17	1,0	0,8	0,67
Extreme ice block mass (m_{ice}) (kg)	8760	5460	2800	1600
C_{DMI} (if not known)	1,3	1,2	1,1	1,0

Table 14 : Impact speeds vs for aft centerline thruster (m/s)

Notations	IA Super	IA	IB	IC
Longitudinal impact in main operational direction	6	5	5	5
Longitudinal impact in reversing direction (pulling unit propeller hub or pushing unit cover end cap impact)	4	3	3	3
Transversal impact in bow first operation	3	2	2	2
Transversal impact in stern first operation (double acting ship)	4	3	3	3

Table 15 : Impact speeds vs for aft, wing, bow centerline and bow wing thrusters (m/s)

Notations	IA Super	IA	IB	IC
Longitudinal impact in main operational direction	6	5	5	5
Longitudinal impact in reversing direction (pulling unit propeller hub or pushing unit cover end cap impact)	4	3	3	3
Transversal impact	4	3	3	

Table 16 : Load cases for ridge ice loads

Load Case	Force	Loaded area	Loaded area
<p>Load case T4a Symmetric longitudinal ridge penetration loads</p>	<p>F_{tr}</p>	<p>Uniform pressure applied symmetrically on the impact area</p>	
<p>Load case T4b Non-symmetric longitudinal ridge penetration loads</p>	<p>50% of F_{tr}</p>	<p>Uniform pressure applied on the other half of the contact area</p>	
<p>Load case T5a Symmetric lateral ridge penetration loads for ducted azimuthing unit and pushing open propeller unit</p>	<p>F_{tr}</p>	<p>Uniform pressure applied symmetrically on the contact area</p>	

Part F

Load Case	Force	Loaded area	
Load case T5b Non-symmetric lateral ridge penetration loads for all azimuthing units	50% of F_{tr}	Uniform pressure applied on the other half of the contact area	

Note 1: For fixed thrusters, only the relevant load cases are to be considered.

1.11.3 Extreme ice loads on thruster hull when penetrating an ice ridge

In icy conditions, ships typically operate in ice channels. When passing other ships, ships may be subject to loads caused by their thrusters penetrating ice channel walls. There is usually a consolidated layer at the ice surface, below which the ice blocks are loose. In addition, the thruster may penetrate ice ridges when backing. Such a situation is likely in the case of ships having a notation **ICE CLASS IA SUPER** in particular, because they may sail independently in difficult ice conditions. However, the thrusters in ships with lower ice classes may also have to withstand such a situation, but at a remarkably lower ship speed.

In this load scenario, the ship is penetrating a ridge in thruster first mode with an initial speed. This situation occurs when a ship with a thruster at the bow moves forward, or a ship with a thruster astern moves in backing mode. The maximum load during such an event is considered the extreme load. An event of this kind typically lasts several seconds, due to which the dynamic magnification is considered negligible and is not taken into account.

The ridge penetration load F_{tr} , in kN, is to be calculated for the load cases shown in Tab 16, using the formula below:

$$F_{tr} = 32v_s^{0,66}H_r^{0,9}A_t^{0,74}$$

where:

- v_s : Ridge penetration speed, in m/s, as given in Tab 17 and Tab 18. On a case by case basis, v_s can also be derived from the ship actual design operation speed in ice, subject to the Society agreement, in m/s
- H_r : Total thickness of the design ridge, in m, as given in Tab 17 and Tab 18
- A_t : Projected area of the thruster, in m², as shown in Tab 16. When calculating the contact area for thruster-ridge interaction, the loaded area in vertical direction is limited to the ice ridge thickness as shown in Fig 11.

The loads must be applied as uniform pressure over the thruster surface.

1.11.4 Acceptability criterion for static loads

The stresses on the thruster have to be calculated for the extreme once in a lifetime loads described in Article [3]. The nominal von Mises stresses on the thruster body must have a safety margin of 1,3 against yielding strength of the material. At areas of local stress concentrations, stresses must have a safety margin of 1,0 against yielding.

The slewing bearing, bolt connections and other components must be able to maintain operability without incurring damage that requires repair when subject to loads given in [1.11.2] and [1.11.3] multiplied by safety factor 1,3.

**Table 17 : Parameters for calculating maximum loads when thruster penetrates an ice ridge
Aft thrusters, bow first operation**

Notations		IA Super	IA	IB	IC
Total thickness of the design ridge (H_r) (m)		8	8	6,5	5
Initial ridge penetration speed (v_s) (m/s)	Longitudinal loads	4	2	2	2
	Transversal loads	2	1	1	1

**Table 18 : Parameters for calculating maximum loads when thruster penetrates an ice ridge
Thruster first mode such as double acting ships**

Notations		IA Super	IA	IB	IC
Total thickness of the design ridge (H_r) (m)		8	8	6,5	5
Initial ridge penetration speed (v_s)(m/s)	Longitudinal loads	6	4	4	4
	Transversal loads	3	2	2	2

Figure 11 : Schematic figure showing the reduction of the contact area by the maximum ridge thickness

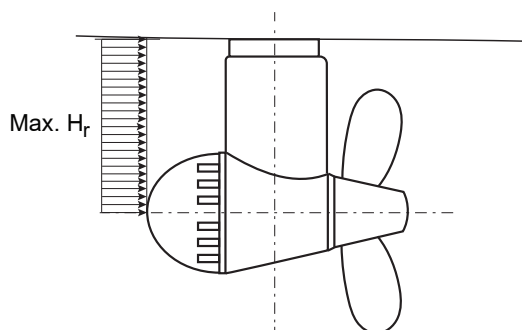

1.11.5 Thruster body global vibration

Evaluating the global vibratory behavior of the thruster body is important, if the first blade order excitations are in the same frequency range with the thruster global modes of vibration, and which occur when the propeller rotational speeds are in the high power range of the propulsion line. This evaluation is mandatory and it must be shown that there is either no global first blade order resonance at high operational propeller speeds (above 50% of maximum power) or that the structure is designed to withstand vibratory loads during resonance above 50% of maximum power.

When estimating thruster global natural frequencies in the longitudinal and transverse direction, the damping and added mass due to water must be taken into account. In addition to this, the effect of ship attachment stiffness is to be modeled.

Ch 8, Sec 3, [3.2.1]

Replace the term “ensure” by “secure” in item a).

Replace the term “about one cubic meter” by “around one cubic meter” in item b), 2).

Replace the term “in ballast conditions” by “in terms of ballast” in item e).

Ch 9, Sec 1, Table 1

Insert the following row as follows:

Table 1 : Additional class notations for the prevention of pollution

Symbol	Scope	Reference to the Rules	Eligible for the assignment of CLEANSHIP SUPER notation	Assignment conditions
CEMS	Fitting of a emission monitoring system	Ch 9, Sec 3, [11]	No	

Ch 9, Sec 1, Table 2

Insert the following row as follows:

Table 2 : Required certificates

Notations	Certificate	Applicable Rules and Regulations
CEMS	Type approval Certificate of the measurement, monitoring and recording equipment	<ul style="list-style-type: none"> IMO Resolution MEPC.103(49) for NO_x emissions IMO Resolution MEPC.259(68) for SO₂ and CO₂ emissions

Ch 9, Sec 2, [2.7]

Replace requirement [2.7.4] by:

2.7.4 Retention facilities

Refrigeration systems are to be fitted with retention facilities having the capability to retain the volume of refrigerant contained in the largest individual refrigeration unit, should the necessity arise to empty any one unit. The retention facilities may be either:

- Fully independent from the refrigeration system, i.e. separate tanks, or
- Part of the refrigeration system, i.e. redundant condensers: In this case, the combined capacity of the conden-

sors is to be sufficient to store the total volume of refrigerant in the system considering that any one condenser is unavailable e.g. for repair or maintenance reasons.

The retention facilities may be tanks for liquid media and/or bottles for gaseous media. If only tanks for liquid are used as retention facilities, one or more compressors having the combined capacity to discharge completely the medium from the system into the tanks are to be installed.

Ch 9, Sec 2, [3]

Delete sub-article [3.8].

Ch 9, Sec 3

Add the following Article [11]:

11 Notation CEMS

11.1 Scope

11.1.1 The notation **CEMS** may be assigned as a complement to **CLEANSHIP** or **CLEANSHIP SUPER** notations, to ships fitted with a measurement, monitoring, recording and transmission equipment in compliance with this article.

11.2 On-board emission measurement and monitoring equipment

11.2.1 Ships having the notation **CEMS** are to be provided with a type-approved measurement, monitoring and recording equipment, for:

- NO_x emissions, in compliance with IMO Resolution MEPC.103(49)
- SO₂ and CO₂ emissions, in compliance with IMO Resolution MEPC.259(68)

Note 1: The correspondence between the SO₂/CO₂ ratio and the sulphur content of the fuel oil is detailed in IMO Resolution MEPC.259(68), Table 1 and Appendix II.

11.3 Remote transmission of the parameters related to waste discharge and air emissions

11.3.1 The following waste discharge and air emission parameters required to be monitored and recorded are to be transmitted on a regular basis (e.g. every day) via a satellite communication system to a shipowner facility ashore:

- NO_x, SO₂ and CO₂ emission records in accordance with [11.2.1]
- Oily waste discharge records, in accordance with Ch 9, Sec 2, [2.2.7]
- Wastewater discharge records, in accordance with Ch 9, Sec 2, [2.3.5], or Ch 9, Sec 2, [3.3.4] as applicable for **CLEANSHIP SUPER** notation
- Garbage waste records, in accordance with Ch 9, Sec 2, [2.4.8]
- For units fitted with a exhaust gas cleaning system, the washwater discharge records, in accordance with IMO Resolution MEPC259(68) Article 10.

11.3.2 Such information is to be made available to the Surveyor of the Society upon request.

Ch 11, Sec 6, [1.2]

Replace requirement [1.2.7] by:

1.2.7 Dynamic positioning control station (DP control station) means a workstation designated for DP operations, where necessary information sources, such as indicators, displays, alarm panels, control panels and internal communication systems are installed (this includes: DP control and

independent joystick control operator stations, required position DP system reference systems' Human Machine Interface (HMI), manual thruster levers, mode change systems, thruster emergency stops, internal communications).

Ch 11, Sec 6, [1.3]

Replace requirement [1.3.1] by:

1.3.1 The installation necessary for dynamically positioning a vessel comprises, but is not limited to, the following sub-systems:

- power system, i.e. all components and systems necessary to supply the DP system with power
- thruster system, i.e. all components and systems necessary to supply the DP system with thrust force and direction
- DP control system, i.e. all control components and systems, hardware and software necessary to dynamically position the vessel.

Ch 11, Sec 6, Table 1

Replace row 2 by:

Add the following new row 23 and footnote (3) as follows:

Table 1 : Documents to be submitted

No.	I/A (1)	Documents to be submitted
2	I	Owner performance request, if any
23	A (3)	FMEA incremental test program (3)
(3) Only when -ITP notation is granted		

Ch 11, Sec 6, [2.3.2]

Replace Note 1 by:

Note 1: The simulation is to take account of the response of the unit to oscillating forces of positive average (waves, wind, possible external links) likely to have a resonant action upon the dynamic system composed of the unit together with its DP system.

Ch 11, Sec 6, [2.4]

Add the following new requirement [2.4.4]:

2.4.4 For ships granted with the notation -ITP, the FMEA incremental test program is to be submitted to the Society for approval, and be available on board.

Ch 11, Sec 6, [4.1]

Replace requirement [4.1.1] by:

4.1.1 All components in a DP system are to comply with the relevant Rules for the Classification of Ships.

Ch 11, Sec 6, [4.2.7]

Replace the first paragraph of first item of the bulleted list by:

- The power available for position keeping is to be sufficient to maintain the vessel in position after worst-case failure as per [3.2.2] and [3.2.3]. The automatic power management system is to be capable of:

Ch 11, Sec 6, Table 2

Replace Table 2 by:

Table 2 : System configuration for main power supply and propulsion systems

Equipment class	-	1	2	3
Additional class notation DYNAPOS	SAM	AM/AT	AM/AT R	AM/AT RS
Distribution system	According to SOLAS and the present Rules		redundant	redundant in separate rooms
Electric generators			redundant	redundant in separate rooms
Main switchboard			1 with bus tie circuit breaker(s) 2 or more circuits equally distributed	2 or more switchboards, with bus tie circuit-breakers normally open, located in separate rooms
Thrusters and associated control systems			redundant	redundant in separate rooms
Power management system			redundant	redundant in separate rooms

Note 1: Redundant is to be understood as defined in [1.2.19].

Ch 11, Sec 6, [4.4]

Replace the requirement [4.4.7] by:

4.4.7 For **DYNAPOS SAM** and **DYNAPOS AM/AT**, an UPS is to be provided for the control of power and propulsion system defined above. To this end, for a system granted symbols R or RS, the number of UPS systems is to be in

accordance with the result of the FMEA analysis. Unless otherwise justified, 2 UPS systems are to be provided for symbol R. For symbol RS, 2 UPS systems are to be installed, one being located in a separate room.

Ch 11, Sec 6, [4.7]

Replace the requirements [4.7.1] to [4.7.7] by:

4.7.1 In general, the DP control system is to be arranged in a DP control station where the operator has a good view of the vessel's exterior limits and the surrounding area.

4.7.2 The DP control station is to display information from the power system, thruster system and DP control system to ensure that these systems are functioning correctly. Information necessary to safely operate the DP system is to be visible at all times. Other information is to be available at the request of the operator.

4.7.3 Display systems, and the DP control station in particular, are to be based on sound ergonomic principles which promote proper operation of the system. The DP control system is to be arranged for easy selection of the control mode, i.e. manual joystick, or automatic DP control of thrusters, propellers and rudders. The active mode is to be clearly displayed. The following principles apply to the display system:

- segregation of redundant equipment to reduce the possibility of common mode failure occurrence
- ease of access for maintenance purposes
- protection against adverse effects from environment and from electrical and electromagnetic disturbances.

4.7.4 For equipment classes 2 and 3, operator controls are to be designed so that no single inadvertent act on the operator's panel can lead to a critical condition.

4.7.5 Alarms and warnings for failures in all systems interfaced to and/or controlled by the DP control system are to be audible and visual. A record of their occurrence and of status changes is to be provided together with any necessary explanations. The alarm list is given for information in Tab 4.

4.7.6 The DP control system is to prevent failures being transferred from one system to another. The redundant components are to be so arranged that any failed component or components can be easily isolated, so that the other component(s) can take over smoothly with no loss of position and/or heading.

4.7.7 It is to be possible to control the thrusters manually, by individual levers and by an independent joystick, in the event of failure of the DP control system. If an independent joystick is provided with sensor inputs, failure of the main DP control system is not to affect the integrity of the inputs to the independent joystick. This requirement may be omitted for installation intended to be assigned the notation **DYNAPOS SAM**.

Ch 11, Sec 6, [4.7]

Replace the requirement [4.7.10] by:

4.7.10 A dedicated UPS is to be provided for each DP control system (i.e. minimum one UPS for equipment class 1, two UPSs for equipment class 2 and three UPSs for equipment class 3 with one being located in a separate room) to ensure that any power failure will not affect more than one computer system and its associated components. The reference systems and sensors are to be distributed on the UPSs in the same manner as the control systems they serve, so

that any power failure will not cause loss of position keeping ability. An alarm is to be initiated in case of loss of charge power. UPS battery capacity is to provide a minimum of 30 minutes operation following a main supply failure. For equipment classes 2 and 3, the charge power for the UPSs supplying the main control system is to originate from different power systems.

Ch 11, Sec 6, [4.8]

Replace the requirements [4.8.1] to [4.8.4] by:

4.8.1 For equipment class 1 (symbol **SAM** or **AM/AT**), the DP control system need not be redundant.

4.8.2 For equipment class 2 (symbol **R**), the DP control system is to consist of at least two computer systems. Common facilities such as self-checking routines, alignment facilities, data transfer arrangements and plant interfaces are not to be capable of causing the failure of more than one computer system. An alarm is to be initiated if any computer fails or is not ready to take control.

4.8.3 For equipment class 3 (symbol **RS**), the DP control system is to consist of at least two computer systems with self-checking facilities. Common facilities such as self-checking routines, alignment facilities, data transfer arrangements and plant interfaces are not to be capable of causing failure of more than one computer system. In addition, one backup DP control system should be arranged. An alarm is to be initiated if any computer fails or is not ready to take control.

4.8.4 For equipment classes 2 (symbol **R**) and 3 (symbol **RS**), the DP control system is to include a software function, normally known as “consequence analysis”, which continuously verifies that the vessel will remain in position even if the worst-case failure occurs. This analysis is to verify that the thrusters, propellers and rudders (if included under DP control) that remain in operation after the worst-case failure can generate the same resultant thruster force and moment as required before the failure. The consequence analysis is to provide an alarm if the occurrence of a worst-case failure would lead to a loss of position and/or heading due to insufficient thrust for the prevailing environmental conditions (e.g. wind, waves, current, etc.). For operations which will take a long time to safely terminate, the consequence analysis is to include a function which simulates the remaining thrust and power after the worst-case failure, based on input of the environmental conditions. Manual input of weather trend or forecast might be possible, in order to integrate relevant meteorological data in the system, if available.

Ch 11, Sec 6, [4.8]

Replace the requirements [4.8.6] and [4.8.8] by:

4.8.6 For equipment class 3 (symbol **RS**), the backup DP control system is to be in a room, separated by an A-60 class division from the main DP control station. During DP operation, this backup control system is to be continuously updated by input from at least one of the required sets of sensors, position reference system, thruster feedback, etc., and to be ready to take over control. The switchover of control to the backup system is to be manual, situated on the backup computer, and is not to be affected by a failure of the main DP control system. Main and backup DP control

systems are to be so arranged that at least one system will be able to perform automatic position keeping after any single failure.

4.8.8 For dynamic positioning control systems based on computer, it is to be demonstrated that the control systems work properly in the environmental conditions prevailing on board ships and offshore platforms. To this end, the DP control systems are to be submitted to the environmental tests defined in Pt C, Ch 3, Sec 6, with special consideration for E.M.I. (Electromagnetic interference).

Ch 11, Sec 6, Table 3

Replace the first row of head table by:

Table 3 : Configuration for reference systems, vessel sensors and computers

Equipment class	-	1	2	3
-----------------	---	---	---	---

Ch 11, Sec 6, [5.1]

Replace the requirement [5.1.1] by:

5.1.1 As a general rule, a dynamic positioning installation is to include at least two independent reference systems:

- for **SAM** notation assignment, only one reference system is required
- for equipment class 1 (**AM/AT**), at least two independent position reference systems are to be installed and simultaneously available to the DP control system during operation
- for equipment classes 2 (symbol **R**) and 3 (symbol **RS**), at least three independent position reference systems

are to be installed and simultaneously available to the DP control system during operation

- position reference systems are to be selected with due consideration to operational requirements, both with regard to restrictions caused by the manner of deployment and expected performance in the working situation
- when two or more position reference systems are required, they are not all to be of the same type, but based on different principles and suitable for the operating conditions, in order to avoid external common cause failure modes.

Ch 11, Sec 6, [5.5]

Replace the requirement [5.5.4] by:

5.5.4 When an equipment class 2 or 3 (for symbols **R** and **RS**), DP control system is fully dependent on correct signals from vessel sensors, then these signals are to be based on

three systems serving the same purpose (i.e., this will result in at least three heading reference sensors being installed).

Ch 11, Sec 6, [6.1]

Replace the requirements [6.1.1] to [6.1.3] by:

6.1.1 For equipment class 2 (symbol **R**), the piping systems for fuel, lubrication, hydraulic oil, cooling water and pneumatic circuits and the cabling of the electric circuits essential for the correct functioning of the DP system are to be located with due regard to fire hazards and mechanical damage.

6.1.2 For equipment class 3 (symbol **RS**):

- Redundant piping systems (i.e., piping for fuel, cooling water, lubrication oil, hydraulic oil and pneumatic circuits etc.) are not to be routed together through the same compartments. Where this is unavoidable, such pipes may run together in ducts of A-60 class, the termination of the ducts included, which are effectively protected from all fire hazards except that represented by the pipes themselves.

- Cables for redundant equipment or systems are not to be routed together through the same compartments. Where this is unavoidable, such cables may run together in cable ducts of A-60 class, the termination of the ducts included, which are effectively protected from all fire hazards except that represented by the cables themselves. Cable connection boxes are not allowed within such ducts.

6.1.3 For equipment classes 2 (symbol **R**) and 3 (symbol **RS**), systems not directly part of the DP system but which, in the event of failure, could cause failure of the DP system (common fire suppression systems, engine ventilation systems, heating, ventilation and air conditioning (HVAC) systems, shutdown systems, etc.) are also to comply with the relevant requirements of these Rules.

Ch 11, Sec 6, [7.1]

Replace the requirement [7.1.2] by:

7.1.2 Before every DP operation, the DP system is to be checked according to an applicable vessel specific "location" checklist(s) and other decision support tools, such as

ASOG, in order to make sure that the DP system is functioning correctly and that it has been set up for the appropriate mode of operation.

Ch 11, Sec 6, [8.2]

Replace the requirement [8.2.1] by:

8.2.1 Before a new installation is put into service and after modification of an existing installation, port and sea trials

are to be carried out to check the proper functioning and performances of the DP system.

Ch 11, Sec 6, [10]

Replace the sub-article [10.2] by:

10.2 DP Control system

10.2.1 The DP control system is to consist of at least a main control system and an alternative control system capable to maintain without disruption the position holding capabilities of the unit in case of complicated failure of the main control system. For equipment class 3 (symbol RS), the backup control system required in [4.8.3] can be considered as the alternative control system.

10.2.2 The alternative DP control system is to operate independently of the main DP control system and for equipment class 2 (symbol R) may be provided in place of independent joystick system required in [4.9]. In this case in addition to the DP capability this system is to satisfy all of the requirements of the independent joystick system.

10.2.3 The main DP control system is to consist of two independent and redundant computer systems as specified in [4.8.2] and [4.8.3]. The alternative DP control system is to consist at least of a single and independent computer system ready to take over control of DP operations at any given times in case of failure of the main DP control system. The switch-over of control of the alternative DP control system is to be manual.

10.2.4 The alternative DP control system is to perform self-checking routines. An audible and visual alarm is to be initiated in the main DP control system in case of failure or unavailability of the alternative DP control system.

10.2.5 For equipment class 2 (symbol R), the main and alternative DP control systems may be located in the same DP control station.

10.2.6 The main and alternative DP control systems are to be powered by independent power supplies and each one by its own uninterruptible power supply (UPS) capable to provide a minimum of 30 minutes operation following main supply outage.

10.2.7 In order to allow post incident analysis, a data logger with a storage capacity of 7 days is to be provided to collect automatically and continuously time-stamped events from the DP control systems. The recorded data are to be easily accessible to the operators and are to be available for upload to an offline storage media.

10.2.8 The following data of the main and alternative DP control system are to be recorded by the data logger:

- Operational status
- All manual input
- All automatic input and output

10.2.9 The main DP control system is to provide online capability plots and online simulation of the position holding capabilities for the most relevant failure modes. These functionalities are to be verified as far as feasible by full scale testing during sea trials.

Ch 11, Sec 6, [10.3]

Replace the requirements [10.3.3] and [10.3.4] by:

10.3.3 Position reference systems are to be independent of each other and supplied from UPSs. Their power supply and interface with DP control systems are to be in accordance with the redundancy requirements but at least one position reference system is to be directly interfaced to the alternative DP control system (DP Class 2) or backup DP control system (DP class 3).

10.3.4 Position reference systems can be interfaced to both DP control systems provided that the failure of a position reference system does not jeopardize the independence requirement between the main and alternative DP control systems.

Ch 11, Sec 6, Table 7

Replace the table foot notes (1), (2), (3) by:

Table 7 : Configuration for reference systems, vessel sensors and computers for enhance reliability DP system

- (1) May be omitted if the alternative DP control system includes also all of the requirements of the independent joystick system
 (2) One of them is to be connected to the alternative DP control system
 (3) One of them is to be connected to the backup DP control system (see (5.2.4) and Table 3)

Ch 11, Sec 6, [10.4]

Replace the requirements [10.4.3] and [10.4.4] by:

10.4.3 Sensors are to be supplied from UPSs. Their power supply and interface with DP control systems are to be in accordance with the redundancy requirements but at least one sensor of each type is to be directly interfaced to the alternative DP control system (DP Class 2) or backup DP control system (DP class 3).

10.4.4 Sensors can be interfaced to both DP control systems provided that the failure of a sensor does not jeopardize the independence requirement between the main and alternative DP control systems.

Ch 11, Sec 21, [3.1]

Replace the requirement [3.1.4] by:

3.1.4 Protection against electrostatic hazard

When hazardous areas may be created regarding criteria of IEC 60079 series, the battery room is to be painted with antistatic paintings in the circulating area.

Battery rooms containing Lithium batteries need not be painted with antistatic paintings, provided it is confirmed by the risk analysis required in Ch 11, Sec 21, [3.2.3].

Replace the second paragraph of [3.1.5] by:

The battery compartment is to be fitted with a fixed fire-extinguishing system according to Pt C, Ch 4, Sec 6, [3.1]. This system is to be compatible with technology of the battery employed, according to the battery's manufacturer specification.

Ch 11, Sec 21, [3.2]

Insert the following new requirement [3.2.1]:

3.2.2 Battery pack cooling

Battery pack cooling is to be ensured either by the ventilation of the battery compartment or by direct cooling (dedicated cooling circuit).

When a direct cooling is installed, the following alarms are to be provided, where applicable:

- High temperature of the cooling air of battery pack provided with forced ventilation (see Note 1)
- Reduced flow of primary and secondary coolants of Battery packs having a closed cooling system with a heat exchanger (see Note 1)

Note 1: As an alternative to the air temperature and to the cooling flow, the supply of electrical energy to the ventilator may be monitored.

Ch 11, Sec 22, Table 1

Replace rows 2, 9 and 10:

Add table foot note (2) as follows:

Table 1 : Documents to be submitted

No.	I/A (1)	Documents
2	I	Power balance, see (2)
9	I	For ZE Mode: Electrical load balance and specified design autonomy period, see [3.5.3]
10	I	For PB Mode: Electrical load balance(s) for power back up, see [3.5.2]

(2) The load balance is to include the battery charging phase. See [2.2.10].

Ch 11, Sec 22, [2.2]

Add the following new requirement [2.2.10]:

2.2.10 PB mode and ZE mode

An electrical load balance corresponding to battery charging mode is to be submitted for information.

The maximum battery charging current is to be taken into account.

Ch 11, Sec 22, [3]

Insert the following new sub-article [3.6]:

3.6 ESS Charging

3.6.1 After partial or full discharge, the charging current of the batteries will be limited due to the high temperature of the battery cells.

Therefore, in PB and ZE mode, the charging current and the time to charge completely the batteries is to be evaluated during a charging test, just after the ESS has been discharged in the conditions of load balance for PB or ZE mode, as defined in [3.5.2] and [3.5.3] respectively.

Ch 11, Sec 22, [5.2.3]

Add the following item at the end of the bulleted list:

- charging test, see [3.6.1].

Ch 11, Sec 22, [5.2.4]

Add the following item at the end of the bulleted list:

- charging test, see [3.6.1].

Ch 11, Sec 24, [3.2.1]

Insert the following Note 1 at the end of item b):

Note 1: Regarding the sea water systems, the attention of the shipyards is drawn on the proper dimensioning of those lines serving EGCS installations.

Chapter 11

Add the following new Section 26:

SECTION 26

ULTRA-LOW EMISSION VESSEL (ULEV)

1 General

1.1 Purpose of the ULEV additional notation

1.1.1 The ULEV additional class notation is providing the status for internal combustion engines installed on a ship regarding their capacity to emit gaseous pollutants and particulate pollutants at a very low level at the moment when they are installed on the ship.

1.1.2 The ULEV additional class notation is assigned, in accordance with Pt A, Ch 1, Sec 2, [6.8.15] to the ship based on the information provided for each engine according to the scope of this additional notation.

1.2 Application

1.2.1 Ships considered

- a) The additional class notation **ULEV** may be assigned to ships which do not fall into the scope of the Regulation (EU) 2016/1628.
- b) Ships that may be granted with the additional notation **ULEV** may be new constructions or Ships in service as long as the engines installed on-board, defined in [1.2.2], comply with the requirements of this Section.

1.2.2 Relation to Regulation (EU) 2016/1628

Compliance with notation **ULEV** cannot be considered as a conformity to the requirements of the Regulation (EU) 2016/1628, which is to be assessed in accordance with applicable EU and national Authority procedures.

1.2.3 Engines considered

Within the scope of **ULEV** notation, all internal combustion engines are to be in compliance with the requirements of this Section, except:

- engines intended to be used only for emergencies, or solely to power any device or equipment intended to be used solely for emergencies on the ship on which it is installed, or an engine installed in lifeboats intended to be used solely for emergencies are not to be taken into account in the scope of this notation
- engines with a power equal to or less than 19 kW shall not be considered in the scope of this notation.

For the purpose of application of the Regulation, the engines under consideration are to be considered as IWP or IWA engines according to Regulation (EU) 2016/1628 as if these engines were installed on an Inland navigation ship.

Other type of engines as mentioned in the same EU Regulation might be considered on case by case basis.

1.3 Definitions

1.3.1 "Gaseous pollutants" means the following pollutants in their gaseous state emitted by an engine: carbon monoxide (CO), total hydrocarbons (HC) and oxides of nitrogen (NO_x); NO_x being nitric oxide (NO) and nitrogen dioxide (NO₂), expressed as NO₂ equivalent.

1.3.2 "Particulate matter" or "PM" means the mass of any material in the gas emitted by an engine that is collected on a specified filter medium after diluting the gas with clean filtered air so that the temperature does not exceed 325 K (52°C).

1.3.3 "Particle number" or "PN" means the number of solid particles emitted by an engine with a diameter greater than 23 nm.

1.3.4 "Particulate pollutants" means any matter emitted by an engine that is measured as PM or PN.

1.3.5 "Internal combustion engine" or "engine" means an energy converter, other than a gas turbine, designed to transform chemical energy (input) into mechanical energy (output) with an internal combustion process; it includes, where they have been installed, the emission control system and the communication interface (hardware and messages) between the engine's electronic control unit(s) and any other powertrain or non-road mobile machinery control unit necessary to comply with the requirements of this notation.

1.3.6 "Manufacturer" means any natural or legal person who is responsible of supervising, organizing the testing sessions and the producing the documentation related to the engine(s) for the purpose of this notation as it would be considered by the approval authority for all aspects of the engine in the case of an EU type-approval or authorisation process and for ensuring conformity of engine production, and who would also be responsible for market surveillance concerns for the engines produced, whether or not they are directly involved in all stages of the design and construction of the engine which would be the subject of the EU type-approval process.

1.3.7 "NO_x Control Diagnostic system (NCD)" means a system on-board the engine which has the capability of:

- a) detecting a NO_x Control Malfunction,
- b) identifying the likely cause of NO_x control malfunctions by means of information stored in computer memory and/or communicating that information off-board.

1.3.8 “Particulate Control Diagnostic system (PCD)” means a system on-board the engine which has a capability of:

- a) detecting a Particulate Control Malfunction
- b) identifying the likely cause of particulate control malfunctions by means of information stored in computer memory and/or communicating that information off-board.

1.3.9 “technical service” means an organisation or body designated by one of the EU national approval authorities dealing with the Regulation and declared to the European Commission as a testing laboratory to carry out tests, or as a conformity assessment body to carry out the initial assessment and other tests or inspections, on behalf of the approval authority, or the authority itself when carrying out those functions. For the purpose of this notation, technical services shall be selected according to the requirements mentioned in [1.4.2].

1.3.10 “the Regulation” means Regulation (EU) 2016/1628 of the European Parliament and of the council of 14 September 2016 on requirements relating to gaseous and particulate pollutant emission limits and type-approval for internal combustion engines for non-road mobile machinery, amending Regulations (EU) No 1024/2012 and (EU) No 167/2013, and amending and repealing Directive 97/68/EC.

1.3.11 “the delegated Regulation 654” means Commission Delegated Regulation (EU) 2017/654 of 19 December 2016 supplementing Regulation (EU) 2016/1628 of the European Parliament and of the Council with regard to technical and general requirements relating to emission limits and type-approval for internal combustion engines for non-road mobile machinery.

1.3.12 “the delegated Regulation 656” means Commission Delegated Regulation (EU) 2017/656 of 19 December 2016 laying down the administrative requirements relating to emission limits and type-approval of internal combustion engines for non-road mobile machinery in accordance with Regulation (EU) 2016/1628 of the European Parliament and of the Council.

1.3.13 “ULEV Mode” is the configuration of the control system of the engine that enables to fulfil the emission limits mentioned in Article [2].

1.4 Entities involved

1.4.1 Selection of a Manufacturer

The Manufacturer is to handle all the aspect related to the requirements of this additional notation and also those included in Part C, Chapter 1 of the Rules related to the type approval of engines. It is the responsibility of the Yard or the Owner to declare the Manufacturer to the Society.

1.4.2 Selection of a technical service

The Manufacturer is to select a technical service in order to proceed with the emission tests on the engines. This technical service is to be recognized as a technical body by one of the EU national approval authorities dealing with the Regulation and declared to the European Commission. Both

these national authorities and technical service are to be mentioned in a relevant up to date publications of the European Union when the notation is granted.

The technical service is to be fulfilling the requirements mentioned in Article 45 and 46 of the Regulation. According to the test conditions expected, the technical service is to be granted with category A or category B by a national authority as per classification described in Article 47 of the Regulation.

1.5 Documents to be submitted

1.5.1 The documents listed in Tab 1 are to be submitted by the Manufacturer.

Table 1 : Documents to be submitted

No	Item	I / A
1	Information folder and information document, as mentioned in delegated Regulation 656 Annex I, as applicable.	I
2	Technical data for prevention of tampering, as mentioned in the delegated Regulation 656 Annex X, as applicable.	I
3	Program of tests and surveys proposed by the manufacturer and approved by the technical service.	I
4	Test Report as mentioned in the delegated Regulation 656 Annex VI, as applicable.	I
5	Details of the relevant information and instruction for end-users as mentioned in the delegated Regulation 654 Annex XV	I
6	Documents issued by the EU showing the endorsement of the technical service by a national approval authority and mentioned in [1.4.2]	I
7	List of all engines installed on board including their purpose of use and serial number and those fulfilling the requirements of Article [2]	A
Note 1: I: For information / A: For approval		

2 Requirements for exhaust gas emissions of engines

2.1 Emission limit

2.1.1 Exhaust emission from the engines mentioned in [1.2.2] shall not overpass limits as mentioned in Annex II of the Regulation.

2.2 Testing and design of engines

2.2.1 Engines as defined in [1.2.2] are to be in compliance with the requirements mentioned in following parts of the delegated Regulation 654:

- Annex I
- Annex III

- Annex IV with following alteration: §2.2.3 of Annex IV of the delegated Regulation does not allow an alternative control different from the one used in the scope of the Regulation. In the scope of the ULEV notation, this is allowed as long as it is possible to record the status of the engine control related to its use in ULEV mode.
- Annex V
- Annex VI
- Annex VII
- Annex VIII
- Annex IX
- Annex XVII.

2.3 Checking of an engine conformity with the emission limits

2.3.1 Direct testing

Direct measurement on an engine is to be undertaken according to the requirements mentioned in [2.2], except in cases specified in [2.3.2].

2.3.2 Conformity with an engine already tested

When an engine can be covered by tests undertaken on another engine, the similarity of design between engines is to be assessed thanks to the documentation provided by the Manufacturer.

3 Test and surveys

3.1 Emission tests

3.1.1 The emission tests are to be attended according to the programme schedule at the satisfaction of the surveyor.

3.2 On-board survey

3.2.1 An on board inspection is to be undertaken by the Surveyor in order to check the conformity of the engine to the information folder and that installation instructions have been followed if any. In particular, the proper operation of the NCD and PCD systems and the proper operation of recording of the status of engine when operated in the ULEV mode are to be tested.



Move Forward with Confidence

Marine & Offshore
8 Cours du Triangle - CS 50101
92937 Paris La Defense Cedex - France
Tel: + 33 (0)1 55 24 70 00
<https://marine-offshore.bureauveritas.com/bv-rules>
© 2019 Bureau Veritas – All rights reserved