



Rules for the Classification of Steel Ships

PART A – Classification and Surveys

NR 467.A1 DT R18 E

July 2021

Marine & Offshore
Le Triangle de l'Arche - 8 cours du Triangle - CS50101
92937 Paris la Défense Cedex- France
Tel: + 33 (0)1 55 24 70 00
<https://marine-offshore.bureauveritas.com/bv-rules>
© 2021 Bureau Veritas - All rights reserved



1. INDEPENDENCE OF THE SOCIETY AND APPLICABLE TERMS

- 1.1 The Society shall remain at all times an independent contractor and neither the Society nor any of its officers, employees, servants, agents or subcontractors shall be or act as an employee, servant or agent of any other party hereto in the performance of the Services.
- 1.2 The operations of the Society in providing its Services are exclusively conducted by way of random inspections and do not, in any circumstances, involve monitoring or exhaustive verification.
- 1.3 The Society acts as a services provider. This cannot be construed as an obligation bearing on the Society to obtain a result or as a warranty. The Society is not and may not be considered as an underwriter, broker in Unit's sale or chartering, expert in Unit's valuation, consulting engineer, controller, naval architect, designer, manufacturer, shipbuilder, repair or conversion yard, charterer or shipowner; none of the above listed being relieved from any of their expressed or implied obligations as a result of the interventions of the Society.
- 1.4 Only the Society is qualified to apply and interpret its Rules.
- 1.5 The Client acknowledges the latest versions of the Conditions and of the applicable Rules applying to the Services' performance.
- 1.6 Unless an express written agreement is made between the Parties on the applicable Rules, the applicable Rules shall be the Rules applicable at the time of entering into the relevant contract for the performance of the Services.
- 1.7 The Services' performance is solely based on the Conditions. No other terms shall apply whether express or implied.

2. DEFINITIONS

- 2.1 "Certificate(s)" means classification or statutory certificates, attestations and reports following the Society's intervention.
- 2.2 "Certification" means the activity of certification in application of national and international regulations or standards ("Applicable Referential"), in particular by delegation from different governments that can result in the issuance of a Certificate.
- 2.3 "Classification" means the classification of a Unit that can result or not in the issuance of a classification Certificate with reference to the Rules. Classification (or Certification as defined in clause 2.2) is an appraisalment given by the Society to the Client, at a certain date, following surveys by its surveyors on the level of compliance of the Unit to the Society's Rules and/or to Applicable Referential for the Services provided. They cannot be construed as an implied or express warranty of safety, fitness for the purpose, seaworthiness of the Unit or of its value for sale, insurance or chartering.
- 2.4 "Client" means the Party and/or its representative requesting the Services.
- 2.5 "Conditions" means the terms and conditions set out in the present document.
- 2.6 "Industry Practice" means international maritime and/or offshore industry practices.
- 2.7 "Intellectual Property" means all patents, rights to inventions, utility models, copyright and related rights, trade marks, logos, service marks, trade dress, business and domain names, rights in trade dress or get-up, rights in goodwill or to sue for passing off, unfair competition rights, rights in designs, rights in computer software, database rights, topography rights, moral rights, rights in confidential information (including know-how and trade secrets), methods and protocols for Services, and any other intellectual property rights, in each case whether capable of registration, registered or unregistered and including all applications for and renewals, reversions or extensions of such rights, and all similar or equivalent rights or forms of protection in any part of the world.
- 2.8 "Parties" means the Society and Client together.
- 2.9 "Party" means the Society or the Client.
- 2.10 "Register" means the public electronic register of ships updated regularly by the Society.
- 2.11 "Rules" means the Society's classification rules (available online on veristar.com), guidance notes and other documents. The Society's Rules take into account at the date of their preparation the state of currently available and proven technical minimum requirements but are not a standard or a code of construction neither a guide for maintenance, a safety handbook or a guide of professional practices, all of which are assumed to be known in detail and carefully followed at all times by the Client.
- 2.12 "Services" means the services set out in clauses 2.2 and 2.3 but also other services related to Classification and Certification such as, but not limited to: ship and company safety management certification, ship and port security certification, maritime labour certification, training activities, all activities and duties incidental thereto such as documentation on any supporting means, software, instrumentation, measurements, tests and trials on board. The Services are carried out by the Society according to the Rules and/or the Applicable Referential and to the Bureau Veritas' Code of Ethics. The Society shall perform the Services according to the applicable national and international standards and Industry Practice and always on the assumption that the Client is aware of such standards and Industry Practice.
- 2.13 "Society" means the classification society 'Bureau Veritas Marine & Offshore SAS', a company organized and existing under the laws of France, registered in Nanterre under number 821 131 844, or any other legal entity of Bureau Veritas Group as may be specified in the relevant contract, and whose main activities are Classification and Certification of ships or offshore units.
- 2.14 "Unit" means any ship or vessel or offshore unit or structure of any type or part of it or system whether linked to shore, river bed or sea bed or not, whether operated or located at sea or in inland waters or partly on land, including submarines, hovercrafts, drilling rigs, offshore installations of any type and of any purpose, their related and ancillary equipment, subsea or not, such as well head and pipelines, mooring legs and mooring points or otherwise as decided by the Society.

- 3.1 Subject to the Services requested and always by reference to the Rules, and/or to the Applicable Referential, the Society shall:
- review the construction arrangements of the Unit as shown on the documents provided by the Client;
 - conduct the Unit surveys at the place of the Unit construction;
 - class the Unit and enter the Unit's class in the Society's Register;
 - survey the Unit periodically in service to note whether the requirements for the maintenance of class are met.
- The Client shall inform the Society without delay of any circumstances which may cause any changes on the conducted surveys or Services.
- 3.2 The Society will not:
- declare the acceptance or commissioning of a Unit, nor its construction in conformity with its design, such activities remaining under the exclusive responsibility of the Unit's owner or builder;
 - engage in any work relating to the design, construction, production or repair checks, neither in the operation of the Unit or the Unit's trade, neither in any advisory services, and cannot be held liable on those accounts.

3. SCOPE AND PERFORMANCE

- 3.1 Subject to the Services requested and always by reference to the Rules, and/or to the Applicable Referential, the Society shall:
- review the construction arrangements of the Unit as shown on the documents provided by the Client;
 - conduct the Unit surveys at the place of the Unit construction;
 - class the Unit and enter the Unit's class in the Society's Register;
 - survey the Unit periodically in service to note whether the requirements for the maintenance of class are met.
- The Client shall inform the Society without delay of any circumstances which may cause any changes on the conducted surveys or Services.
- 3.2 The Society will not:
- declare the acceptance or commissioning of a Unit, nor its construction in conformity with its design, such activities remaining under the exclusive responsibility of the Unit's owner or builder;
 - engage in any work relating to the design, construction, production or repair checks, neither in the operation of the Unit or the Unit's trade, neither in any advisory services, and cannot be held liable on those accounts.

4. RESERVATION CLAUSE

- 4.1 The Client shall always: (i) maintain the Unit in good condition after surveys; (ii) present the Unit for surveys; and (iii) inform the Society in due time of any circumstances that may affect the given appraisalment of the Unit or cause to modify the scope of the Services.
- 4.2 Certificates are only valid if issued by the Society.
- 4.3 The Society has entire control over the Certificates issued and may at any time withdraw a Certificate at its entire discretion including, but not limited to, in the following situations: where the Client fails to comply in due time with instructions of the Society or where the Client fails to pay in accordance with clause 6.2 hereunder.
- 4.4 The Society may at times and at its sole discretion give an opinion on a design or any technical element that would 'in principle' be acceptable to the Society. This opinion shall not presume on the final issuance of any Certificate nor on its content in the event of the actual issuance of a Certificate. This opinion shall only be an appraisalment made by the Society which shall not be held liable for it.

5. ACCESS AND SAFETY

- 5.1 The Client shall give to the Society all access and information necessary for the efficient performance of the requested Services. The Client shall be the sole responsible for the conditions of presentation of the Unit for tests, trials and surveys and the conditions under which tests and trials are carried out. Any information, drawing, etc. required for the performance of the Services must be made available in due time.
- 5.2 The Client shall notify the Society of any relevant safety issue and shall take all necessary safety-related measures to ensure a safe work environment for the Society or any of its officers, employees, servants, agents or subcontractors and shall comply with all applicable safety regulations.

6. PAYMENT OF INVOICES

- 6.1 The provision of the Services by the Society, whether complete or not, involves, for the part carried out, the payment of fees thirty (30) days upon issuance of the invoice.
- 6.2 Without prejudice to any other rights hereunder, in case of Client's payment default, the Society shall be entitled to charge, in addition to the amount not properly paid, interest equal to twelve (12) months LIBOR plus two (2)

per-cent as of due date calculated on the number of days such payment is delinquent. The Society shall also have the right to withhold Certificates and other documents and/or to suspend or revoke the validity of Certificates.

- 6.3 In case of dispute on the invoice amount, the undisputed portion of the invoice shall be paid and an explanation on the dispute shall accompany payment so that action can be taken to resolve the dispute.

7. LIABILITY

- 7.1 The Society bears no liability for consequential loss. For the purpose of this clause consequential loss shall include, without limitation:
- Indirect or consequential loss;
 - Any loss and/or deferral of production, loss of product, loss of use, loss of bargain, loss of revenue, loss of profit or anticipated profit, loss of business and business interruption, in each case whether direct or indirect.
- The Client shall defend, release, save, indemnify, defend and hold harmless the Society from the Client's own consequential loss regardless of cause.
- 7.2 Except in case of wilful misconduct of the Society, death or bodily injury caused by the Society's negligence and any other liability that could not be, by law, limited, the Society's maximum liability towards the Client is limited to one hundred and fifty per-cent (150%) of the price paid by the Client to the Society for the Services having caused the damage. This limit applies to any liability of whatsoever nature and howsoever arising, including fault by the Society, breach of contract, breach of warranty, tort, strict liability, breach of statute.
- 7.3 All claims shall be presented to the Society in writing within three (3) months of the completion of Services' performance or (if later) the date when the events which are relied on were first discovered by the Client. Any claim not so presented as defined above shall be deemed waived and absolutely time barred.

8. INDEMNITY CLAUSE

- 8.1 The Client shall defend, release, save, indemnify and hold harmless the Society from and against any and all claims, demands, lawsuits or actions for damages, including legal fees, for harm or loss to persons and/or property tangible, intangible or otherwise which may be brought against the Society, incidental to, arising out of or in connection with the performance of the Services (including for damages arising out of or in connection with opinions delivered according to clause 4.4 above) except for those claims caused solely and completely by the gross negligence of the Society, its officers, employees, servants, agents or subcontractors.

9. TERMINATION

- 9.1 The Parties shall have the right to terminate the Services (and the relevant contract) for convenience after giving the other Party thirty (30) days' written notice, and without prejudice to clause 6 above.
- 9.2 The Services shall be automatically and immediately terminated in the event the Client can no longer establish any form of interest in the Unit (e.g. sale, scrapping).
- 9.3 The Classification granted to the concerned Unit and the previously issued Certificates shall remain valid until the date of effect of the termination notice issued, or immediately in the event of termination under clause 9.2, subject to compliance with clause 4.1 and 6 above.
- 9.4 In the event where, in the reasonable opinion of the Society, the Client is in breach, or is suspected to be in breach of clause 16 of the Conditions, the Society shall have the right to terminate the Services (and the relevant contracts associated) with immediate effect.

10. FORCE MAJEURE

- 10.1 Neither Party shall be responsible or liable for any failure to fulfil any term or provision of the Conditions if and to the extent that fulfillment has been delayed or temporarily prevented by a force majeure occurrence without the fault or negligence of the Party affected and which, by the exercise of reasonable diligence, the said Party is unable to provide against.
- 10.2 For the purpose of this clause, force majeure shall mean any circumstance not being within a Party's reasonable control including, but not limited to: acts of God, natural disasters, epidemics or pandemics, wars, terrorist attacks, riots, sabotages, impositions of sanctions, embargoes, nuclear, chemical or biological contaminations, laws or action taken by a government or public authority, quotas or prohibition, expropriations, destructions of the worksite, explosions, fires, accidents, any labour or trade disputes, strikes or lockouts.

11. CONFIDENTIALITY

- 11.1 The documents and data provided to or prepared by the Society in performing the Services, and the information made available to the Society, will be treated as confidential except where the information:
- is properly and lawfully in the possession of the Society;
 - is already in possession of the public or has entered the public domain, other than through a breach of this obligation;
 - is acquired or received independently from a third party that has the right to disseminate such information;
 - is required to be disclosed under applicable law or by a governmental order, decree, regulation or rule or by a stock exchange authority (provided that the receiving Party shall make all reasonable efforts to give prompt written notice to the disclosing Party prior to such disclosure).
- 11.2 The Parties shall use the confidential information exclusively within the framework of their activity underlying these Conditions.
- 11.3 Confidential information shall only be provided to third parties with the prior written consent of the other Party. However, such prior consent shall not be required when the Society provides the confidential information to a subsidiary.
- 11.4 Without prejudice to sub-clause 11.1, the Society shall have the right to disclose the confidential information if required to do so under regulations of the International Association of Classification Societies (IACS) or any statutory obligations.

12. INTELLECTUAL PROPERTY

- 12.1 Each Party exclusively owns all rights to its Intellectual Property created before or after the commencement date of the Conditions and whether or not associated with any contract between the Parties.
- 12.2 The Intellectual Property developed by the Society for the performance of the Services including, but not limited to drawings, calculations, and reports shall remain the exclusive property of the Society.

13. ASSIGNMENT

- 13.1 The contract resulting from to these Conditions cannot be assigned or transferred by any means by a Party to any third party without the prior written consent of the other Party.
- 13.2 The Society shall however have the right to assign or transfer by any means the said contract to a subsidiary of the Bureau Veritas Group.

14. SEVERABILITY

- 14.1 Invalidation of one or more provisions does not affect the remaining provisions.
- 14.2 Definitions herein take precedence over other definitions which may appear in other documents issued by the Society.
- 14.3 In case of doubt as to the interpretation of the Conditions, the English text shall prevail.

15. GOVERNING LAW AND DISPUTE RESOLUTION

- 15.1 These Conditions shall be construed in accordance with and governed by the laws of England and Wales.
- 15.2 Any dispute shall be finally settled under the Rules of Arbitration of the Maritime Arbitration Chamber of Paris ("CAMP"), which rules are deemed to be incorporated by reference into this clause. The number of arbitrators shall be three (3). The place of arbitration shall be Paris (France). The Parties agree to keep the arbitration proceedings confidential.
- 15.3 Notwithstanding clause 15.2, disputes relating to the payment of the Society's invoices may be submitted by the Society to the *Tribunal de Commerce de Nanterre*, France, or to any other competent local Court, at the Society's entire discretion.

16. PROFESSIONAL ETHICS

- 16.1 Each Party shall conduct all activities in compliance with all laws, statutes, rules, economic and trade sanctions (including but not limited to US sanctions and EU sanctions) and regulations applicable to such Party including but not limited to: child labour, forced labour, collective bargaining, discrimination, abuse, working hours and minimum wages, anti-bribery, anti-corruption, copyright and trademark protection, personal data protection (<https://personaldataprotection.bureauveritas.com/prvacpolicity>).
- Each of the Parties warrants that neither it, nor its affiliates, has made or will make, with respect to the matters provided for hereunder, any offer, payment, gift or authorization of the payment of any money directly or indirectly, to or for the use or benefit of any official or employee of the government, political party, official, or candidate.
- 16.2 In addition, the Client shall act consistently with the Bureau Veritas' Code of Ethics and, when applicable, Business Partner Code of Conduct both available at <https://group.bureauveritas.com/group/corporate-social-responsibility/operational-excellence>.



RULES FOR THE CLASSIFICATION OF SHIPS

Part A Classification and Surveys

Chapters 1 2 3 4 5 6

Chapter 1	PRINCIPLES OF CLASSIFICATION AND CLASS NOTATIONS
Chapter 2	ASSIGNMENT, MAINTENANCE, SUSPENSION AND WITHDRAWAL OF CLASS
Chapter 3	SCOPE OF SURVEYS (All Ships)
Chapter 4	SCOPE OF SURVEYS IN RESPECT OF THE DIFFERENT SERVICES OF SHIPS
Chapter 5	SCOPE OF SURVEYS RELATED TO ADDITIONAL CLASS NOTATIONS
Chapter 6	RETROACTIVE REQUIREMENTS FOR EXISTING SHIPS

The English wording of these rules take precedence over editions in other languages.

Unless otherwise specified, these rules apply to ships for which contracts are signed after July 1st, 2021. The Society may refer to the contents hereof before July 1st, 2021, as and when deemed necessary or appropriate.

CHAPTER 1

PRINCIPLES OF CLASSIFICATION AND CLASS NOTATIONS

Section 1 General Principles of Classification

1	Principles of classification	31
1.1	Purpose of the Rules	
1.2	General definitions	
1.3	Meaning of classification, scope and limits	
1.4	Request for services	
1.5	Register of ships	
2	Rules	32
2.1	Effective date	
2.2	Equivalence	
2.3	Novel features	
2.4	Disagreement and appeal	
3	Duties of the Interested Parties	33
3.1	International and national regulations	
3.2	Surveyor's intervention	
3.3	Operation and maintenance of ships	
3.4	Flag and Port State Control inspections	
3.5	Use of measuring equipment and of service suppliers	
3.6	Spare parts	
3.7	Quality system audits	
4	Application of statutory requirements by the Society	34
4.1	International and national regulations	

Section 2 Classification Notations

1	General	35
1.1	Purpose of the classification notations	
1.2	Types of notations assigned	
2	Class symbol	35
2.1	General	
3	Construction marks	36
3.1	General	
3.2	List of construction marks	
4	Service notations and corresponding additional service features	36
4.1	General	
4.2	Cargo ships	
4.3	Bulk, ore and combination carriers	
4.4	Ships carrying liquid cargo in bulk	
4.5	Ships carrying passengers	
4.6	Ships for dredging activities	
4.7	Tugs	
4.8	Working ships	
4.9	Offshore service vessels	

4.10	Non-propelled units, assisted propulsion units and other units	
4.11	Fishing vessels	
4.12	High speed crafts (HSC)	
4.13	Ships with low flashpoint liquid or gas fuelled propulsion	
4.14	Icebreaker ships	
4.15	Elastic shaft alignment for line shafting and structure compatibility	
4.16	Miscellaneous units	
4.17	Miscellaneous service features	
5	Navigation and operating area notations	56
5.1	Navigation notations	
5.2	List of navigation notations	
5.3	Operating area notations	
6	Additional class notations	58
6.1	General	
6.2	VeriSTAR and STAR notations	
6.3	Availability of machinery (AVM)	
6.4	Automated machinery systems (AUT)	
6.5	Integrated ship systems (SYS)	
6.6	Monitoring equipment (MON)	
6.7	Comfort on board ships (COMF)	
6.8	Pollution prevention	
6.9	Refrigerating installations	
6.10	Navigation in ice	
6.11	Navigation in polar waters	
6.12	Lifting appliances	
6.13	Emergency response service (ERS)	
6.14	Other additional class notations	
6.15	System fitted but not required by the rules	
7	Other notations	78
7.1		
8	Diving systems	78
8.1	General	

Appendix 1 Notations Assigned According to Editions of the Rules Former to June 2000 Edition

1	Application for surveys and correspondence with current notations	80
1.1	General	
1.2	Phasing out from former to current notations	
1.3	Application of scope of surveys	
1.4	Correspondence between former and current notations	

CHAPTER 2

ASSIGNMENT, MAINTENANCE, SUSPENSION AND WITHDRAWAL OF CLASS

Section 1 Assignment of Class

1	General	87
1.1		
2	New building procedure	87
2.1	Ships surveyed by the Society during construction	
2.2	Other cases	
2.3	Documentation	
3	Ships classed after construction	88
3.1	General	
3.2	Ships classed with a Classification Society subject to compliance with QSCS, reported as compliant by the Losing Society	
3.3	Non-compliant ships	
4	Date of initial classification	91
4.1	Definitions	
5	Reassignment of class	91
5.1		

Section 2 Maintenance of Class

1	General principles of surveys	92
1.1	Survey types	
1.2	Change of periodicity, postponement or advance of surveys	
1.3	Extension of scope of survey	
1.4	General procedure of survey	
1.5	Appointment of another Surveyor	
2	Definitions and procedures related to surveys	93
2.1	General	
2.2	Terminology related to hull survey	
2.3	Procedures for thickness measurements	
2.4	Agreement of firms for in-water survey	
2.5	Preparations and conditions for surveys	
2.6	Access to structures	
2.7	Equipment for surveys	
2.8	Rescue and emergency response equipment	
2.9	Surveys at sea and anchorage	
2.10	Repairs and maintenance during voyage	
2.11	Repairs	
2.12	Remote Inspection Techniques (RIT)	

3	Certificate of Classification: issue, validity, endorsement and renewal	99
	3.1 Issue of Certificate of Classification	
	3.2 Validity of Certificate of Classification, maintenance of class	
	3.3 Endorsement of Certificate of Classification	
	3.4 Status of surveys and conditions of class	
4	Class renewal survey	99
	4.1 General principles	
	4.2 Normal survey system (SS)	
	4.3 Continuous survey system (CS)	
	4.4 Planned maintenance survey system for machinery (PMS)	
5	Other periodical surveys	101
	5.1 General	
	5.2 Annual surveys	
	5.3 Intermediate surveys	
	5.4 Bottom survey	
	5.5 Tailshaft survey	
	5.6 Boiler survey	
	5.7 Links between anniversary dates and annual surveys, intermediate surveys and class renewal surveys	
6	Occasional surveys	104
	6.1 General	
	6.2 Damage and repair surveys	
	6.3 Port State Control survey	
	6.4 Conversions, alterations and repairs	
	6.5 Quality System audits	
	6.6 Unscheduled surveys	
7	Change of ownership	105
	7.1	
8	Lay-up and re-commissioning	105
	8.1 General principles	
9	Safety Management System	106
	9.1	

Section 3 Suspension and Withdrawal of Class

1	General	107
	1.1 Discontinuance of class	
	1.2 Suspension of class	
	1.3 Withdrawal of class	
	1.4 Suspension/withdrawal of additional class notations	

Appendix 1 Planned Maintenance Survey System

1	General	109
	1.1	

2	Conditions and procedures for the review of the system	109
	2.1 General	
	2.2 Documentation	
	2.3 Information on board	
	2.4 List of items	
3	Implementation of the system	110
	3.1	
4	Retention and withdrawal of the system	110
	4.1	
5	Surveys	110
	5.1 Implementation survey	
	5.2 Annual audit and confirmatory surveys	
	5.3 Damage and repairs	

Appendix 2 CSM and PMS Systems: Surveys Carried out by the Chief Engineer

1	Conditions	112
	1.1	
2	Limits of the interventions	112
	2.1	
3	Procedure for carrying out surveys	112
	3.1 General	
	3.2 Main diesel engines	
	3.3 Auxiliary diesel engines	
	3.4 Reciprocating compressors	
	3.5 Coolers, condensers, heaters	
	3.6 Electrical switchboard	
	3.7 a.c. and d.c. generators	
	3.8 Other items (pumps, electric motors, etc.)	
4	Records of surveys carried out	113
	4.1	
5	Confirmatory survey	113
	5.1	
6	Suspension of the Chief Engineer's authorization	114
	6.1	

Appendix 3 Thickness Measurements: Extent, Determination of Locations, Acceptance Criteria

1	General	115
	1.1 Aim of the Appendix	
	1.2 Scope of the Appendix	
2	Rule requirements for the extent of measurements	115
	2.1 General	
	2.2 Class renewal survey: all ships except those submitted to ESP or equivalent	
	2.3 Class renewal survey: ships submitted to ESP or equivalent	

3	Number and locations of measurements	117
3.1	General	
3.2	Locations of points	
4	Acceptance criteria for thickness measurements	129
4.1	General	
4.2	Criteria	
4.3	Local and global strength criteria	
4.4	Buckling strength criterion	
4.5	Pitting	
4.6	Hull supporting structure of shipboard fittings associated with towing and mooring	
4.7	Ice strengthened structures for ships assigned with additional class notation for navigation in polar waters	
4.8	Acceptance criteria for CSR ships	
4.9	Acceptance criteria for container ships	

Appendix 4 Condition Monitoring and Condition Based Maintenance

1	General	141
1.1	Application	
1.2	Definitions	
1.3	Condition monitoring (CM)	
1.4	Condition based maintenance (CBM)	
2	Procedures and conditions for approval of CM and CBM	142
2.1	Onboard responsibility	
2.2	Equipment and systems requirements	
2.3	Documentation and information	
2.4	Approval validity	
3	Surveys	143
3.1	Installation survey	
3.2	Implementation survey	
3.3	Annual audit	
3.4	Damage and repairs	

CHAPTER 3

SCOPE OF SURVEYS (ALL SHIPS)

Section 1 Annual Survey

1	General	147
	1.1	
2	Hull	147
	2.1 Hull and hull equipment	
	2.2 Survey of watertight cable transits	
	2.3 Hatch covers and coamings	
3	Machinery and systems	149
	3.1 General machinery installations	
	3.2 Boilers	
	3.3 Electrical machinery and equipment	
	3.4 Fire protection, detection and extinction	
	3.5 General emergency alarm system	

Section 2 Intermediate Survey

1	General	153
	1.1	
2	Hull	153
	2.1	

Section 3 Class Renewal Survey

1	General	154
	1.1	
2	Hull and hull equipment	154
	2.1 Bottom survey in dry condition	
	2.2 Decks, hatch covers and equipment	
	2.3 Survey of watertight cable transits	
	2.4 Holds and other dry compartments	
	2.5 Tanks	
	2.6 Thickness measurements	
	2.7 Independent cargo tanks	
3	Machinery and systems	158
	3.1 General	
	3.2 Main and auxiliary engines and turbines	
	3.3 Reduction gears, main thrust and intermediate shaft(s)	
	3.4 Pumps and other machinery items	
	3.5 Systems in machinery spaces	
	3.6 Electrical equipment and installations	
	3.7 Controls	
	3.8 Fire protection, detection and extinction	
	3.9 Hold, ballast and dry spaces water level detectors	
	3.10 Availability of pumping systems	

Section 4 Bottom Survey

1	General	163
	1.1	
2	Bottom survey in dry condition	163
	2.1 General requirements	
	2.2 Bottom survey held within the scope of class renewal survey	
3	Bottom in-water survey	163
	3.1 General	

Section 5 Tailshaft Survey

1	Survey of tailshafts	165
	1.1 General	
	1.2 Complete survey	
	1.3 Modified survey	
2	Periodical survey of other propulsion systems	166
	2.1 Rotating and azimuth thrusters	
	2.2 Vertical axis propellers	
	2.3 Pump jet systems	
	2.4 Pod propulsion systems	
3	Survey of propeller shafts and tube shafts	166
	3.1 General	
	3.2 Oil lubricated shafts or closed loop system fresh water lubricated shafts (closed system)	
	3.3 Water lubricated shafts (open systems)	

Section 6 Boiler Survey

1	Steam boilers	174
	1.1	
2	Thermal oil heaters	174
	2.1	

Section 7 Hull Survey for New Construction

1	General	176
	1.1	
2	Documentation to be available for the Surveyor during construction	176
	2.1	
3	Ship construction file	176
	3.1 Ship Construction File (SCF) for all ships, except those specified in [1.1.3]	
	3.2 Ship Construction File (SCF) for ships as specified in [1.1.3]	

4	Newbuilding survey planning	181
	4.1	
5	Examination and test plan for newbuilding activities	182
	5.1 Applicable to all ships	
	5.2 Applicable for ships as specified in [1.1.3]	
6	Design transparency	183
	6.1 Applicable for ships as specified in [1.1.3]	

Section 8 Survey of Watertight Cable Transits

1	General	184
	1.1 Application	
2	Cable Transit Seal Systems Register	184
	2.1 New construction	
	2.2 Vessel in service	
3	Installation and maintenance of Watertight Cable transits	184
	3.1	

Appendix 1 Class Requirements and Surveys of Laid-up Ships

1	General	185
	1.1	
2	Safety conditions	185
	2.1	
3	Preservation measures for lay-up and maintenance	185
	3.1 General	
	3.2 Exposed parts of the hull	
	3.3 Internal spaces	
	3.4 Deck fittings	
	3.5 Machinery	
	3.6 Electrical installations	
	3.7 Steering gear	
	3.8 Boilers	
	3.9 Automated installation	
4	Lay-up site and mooring arrangements	188
	4.1 General	
	4.2 Recommendations for the lay-up site	
	4.3 Recommendations for the mooring arrangements	
	4.4 Review of the mooring arrangements	
5	Surveys	189
	5.1 Laying-up survey	
	5.2 Annual lay-up condition survey	
	5.3 Re-commissioning survey	

CHAPTER 4

SCOPE OF SURVEYS IN RESPECT OF THE DIFFERENT SERVICES OF SHIPS

Section 1 General

1	General	193
	1.1	
2	Service notations and/or additional service features subject to additional surveys	193
	2.1	

Section 2 Single Skin and Double Skin Bulk Carriers

1	General	195
	1.1 Application	
	1.2 Documentation on board	
	1.3 Reporting and evaluation of surveys	
	1.4 Conditions for survey	
	1.5 Access to structures	
2	Annual survey	198
	2.1 General	
	2.2 Hatch covers and coamings, weather decks	
	2.3 Cargo holds	
	2.4 Ballast tanks	
3	Intermediate survey	200
	3.1 Ships 10 years of age or less	
	3.2 Ships between 10 and 15 years of age	
	3.3 Ships over 15 years of age	
4	Class renewal survey	202
	4.1 Survey programme and preparation for survey	
	4.2 Survey planning meeting	
	4.3 Scope of survey	
	4.4 Hatch covers and coamings	
	4.5 Overall and close-up surveys	
	4.6 Thickness measurements	
	4.7 Tank testing	

Section 3 Oil Tankers and Combination Carriers

1	General	215
	1.1 Application	
	1.2 Documentation on board	
	1.3 Reporting and evaluation of surveys	
	1.4 Conditions for survey	
	1.5 Access to structures	

2	Annual survey - Hull items	216
	2.1 General	
	2.2 Weather decks	
	2.3 Cargo pump rooms and pipe tunnels	
	2.4 Ballast tanks	
	2.5 Emergency towing arrangement	
	2.6 Safe access to tanker bows	
	2.7 Means of access	
	2.8 Coating systems	
3	Annual survey - Cargo machinery items	217
	3.1 Cargo area and cargo pump rooms	
	3.2 Instrumentation and safety devices	
	3.3 Fire-fighting systems in cargo area	
	3.4 Inert gas system	
4	Intermediate survey - Hull items	219
	4.1 General	
	4.2 Ships between 5 and 10 years of age	
	4.3 Ships between 10 and 15 years of age	
	4.4 Ships over 15 years of age	
5	Intermediate survey - Cargo machinery items	219
	5.1 Cargo area and cargo pump rooms	
	5.2 Inert gas system	
6	Class renewal survey - Hull items	220
	6.1 Survey programme and preparation for hull survey	
	6.2 Survey planning meeting	
	6.3 Scope of survey	
	6.4 Overall and close-up surveys	
	6.5 Thickness measurements	
	6.6 Tank testing	
	6.7 Cargo piping, area and pump rooms	
	6.8 Emergency towing arrangement	
7	Class renewal survey - Cargo machinery items	230
	7.1 Cargo area and cargo pump rooms	
	7.2 Fire-fighting systems in cargo area	
	7.3 Inert gas system	

Section 4 Chemical Tankers

1	General	231
	1.1 Application	
	1.2 Documentation on board	
	1.3 Reporting and evaluation of surveys	
	1.4 Conditions for survey	
	1.5 Access to structures	
2	Annual survey - Hull items	232
	2.1 General	
	2.2 Weather decks	
	2.3 Cargo pump rooms and pipe tunnels	
	2.4 Ballast tanks	
	2.5 Emergency towing arrangement	

3	Annual survey - Cargo machinery items	233
	3.1 Cargo area and cargo pump rooms	
	3.2 Instrumentation and safety devices	
	3.3 Fire-fighting systems in cargo area	
	3.4 Inert gas system and inert/padding/ drying gas	
4	Intermediate survey - Hull items	234
	4.1 General	
	4.2 Ships between 5 and 10 years of age	
	4.3 Ships between 10 and 15 years of age	
	4.4 Ships over 15 years of age	
5	Intermediate survey - Cargo machinery items	234
	5.1 Cargo area and cargo pump rooms	
	5.2 Inert gas system	
	5.3 Personnel protection	
6	Class renewal survey - Hull items	235
	6.1 Survey program and preparation for survey	
	6.2 Survey planning meeting	
	6.3 Scope of survey	
	6.4 Overall and close-up surveys	
	6.5 Thickness measurements	
	6.6 Tank testing	
	6.7 Cargo piping, cargo pump rooms and cargo tanks	
	6.8 Emergency towing arrangement	
7	Class renewal survey - Cargo machinery items	243
	7.1 Cargo area and cargo pump rooms	
	7.2 Fire-fighting systems in cargo area	
	7.3 Inert gas system	
	7.4 Personnel protection	

Section 5 Liquefied Gas Carriers

1	General	244
	1.1 Application	
2	Annual survey - Hull items	244
	2.1 General	
	2.2 Weather decks and suspect areas	
	2.3 Cargo handling rooms and piping	
	2.4 Other arrangements or devices	
	2.5 Ballast tanks	
	2.6 Emergency towing arrangement	
3	Annual survey - Cargo machinery items	246
	3.1 Cargo area and cargo pump rooms	
	3.2 Instrumentation and safety devices	
	3.3 Fire-fighting systems in cargo area	
	3.4 Environmental control for cargo containment systems	
4	Intermediate survey - Hull items	247
	4.1 General	
	4.2 Weather decks, cargo handling rooms and piping	
	4.3 Ballast tanks	

5	Intermediate survey - Cargo machinery items	247
	5.1 General	
	5.2 Cargo area and cargo pump rooms	
	5.3 Instrumentation and safety devices	
	5.4 Inert gas system	
	5.5 Personnel protection	
6	Class renewal survey - Hull items	249
	6.1 Preparation for survey	
	6.2 Survey programme	
	6.3 Scope of survey	
	6.4 Overall and close-up surveys	
	6.5 Thickness measurements	
	6.6 Tank testing	
	6.7 Cargo tank structure	
	6.8 Weather decks, cargo handling rooms and piping	
	6.9 Emergency towing arrangement	
7	Class renewal survey - Cargo machinery items	252
	7.1 Cargo area, cargo pump rooms, cargo compressor rooms	
	7.2 Fire-fighting systems in cargo area	
	7.3 Inert gas system	
	7.4 Personnel protection	
8	First loaded voyage of ships carrying liquefied natural gases (LNG) in bulk	253
	8.1	
9	Revaporisation installation	253
	9.1 Application	
	9.2 Annual survey	
	9.3 Intermediate survey	
	9.4 Class renewal survey	
10	STL-SPM	255
	10.1 Application	
	10.2 Annual survey	
	10.3 Intermediate survey	
	10.4 Class renewal survey	
	10.5 Bottom survey	

Section 6 Ro-Ro Cargo Ships, PCT Carriers, Passenger Ships, Ro-Ro Passenger Ships

1	General	258
	1.1	
2	Ro-ro cargo ships and PCT Carriers - Annual survey	258
	2.1 Shell and inner doors	
	2.2 Internal platforms and ramps	
	2.3 Fire protection, detection and extinction	
3	Ro-ro cargo ships and PCT carriers - Class renewal survey	259
	3.1 Shell and inner doors	
	3.2 Internal platforms and ramps	
	3.3 Fire protection, detection and extinction	

4	Passenger ships - Annual survey	260
	4.1 Watertight bulkheads	
	4.2 Openings in shell plating	
	4.3 Miscellaneous	
5	Passenger ships - Class renewal survey	260
	5.1	
6	Ro-ro passenger ships - Annual and class renewal surveys	260
	6.1	

Section 7 General Cargo Ships

1	General	261
	1.1 Application	
	1.2 Reporting and evaluation of surveys	
2	Annual survey	261
	2.1 General	
	2.2 Hatch covers and coamings	
	2.3 Cargo holds	
	2.4 Ballast tanks	
3	Intermediate survey	262
	3.1 General	
	3.2 Ships 15 years of age or less	
	3.3 Ships over 15 years of age	
4	Class renewal survey	263
	4.1 Preparation for survey	
	4.2 Scope of survey	
	4.3 Hatch covers and coamings	
	4.4 Overall and close-up surveys	
	4.5 Thickness measurements	
	4.6 Tank testing	

Section 8 Other Service Notations

1	General	268
	1.1	
2	Container ship or ship equipped for the carriage of containers	268
	2.1 Annual survey	
	2.2 Class renewal survey	
3	Livestock carrier	268
	3.1 Annual survey	
	3.2 Class renewal survey	
4	FLS tanker	269
	4.1 Annual survey - Hull items	
	4.2 Annual survey - Cargo machinery items	
	4.3 Intermediate survey - Hull items	

	4.4	Intermediate survey - Cargo machinery items	
	4.5	Class renewal survey - Hull items	
	4.6	Class renewal survey - Cargo machinery items	
5		Dredging units	271
	5.1	Annual survey	
	5.2	Class renewal survey	
6		Tug, salvage tug, escort tug	271
	6.1	Annual survey	
	6.2	Class renewal survey	
7		Supply vessel	272
	7.1	General	
	7.2	Annual survey - Hull items	
	7.3	Annual survey - Cargo machinery items	
	7.4	Intermediate survey - Hull items	
	7.5	Intermediate survey - Cargo machinery items	
	7.6	Class renewal survey - Hull items	
	7.7	Class renewal survey - Cargo machinery items	
8		Fire-fighting ship	273
	8.1	Annual survey	
	8.2	Class renewal survey	
9		Oil recovery ship	274
	9.1	Annual survey	
	9.2	Class renewal survey	
10		Anchor handling vessel	275
	10.1	Annual survey	
	10.2	Class renewal survey	
11		Cable laying ship	276
	11.1	Annual survey	
	11.2	Class renewal survey	
12		Lifting	276
	12.1	General	
	12.2	Annual survey	
	12.3	Class renewal survey	
13		Diving support-integrated and diving support-portable	276
	13.1	Annual survey	
	13.2	Class renewal survey	
14		Fishing vessel	277
	14.1	Annual survey	
	14.2	Class renewal survey	
15		Standby and rescue vessel	277
	15.1	Annual survey - Rescue arrangement, survivors accommodation and safety equipment	
	15.2	Annual survey - Towing arrangements	
	15.3	Class renewal survey - Rescue arrangement, survivors accommodation and safety equipment	
	15.4	Class renewal survey - Towing arrangements	

16	Yacht and charter yacht	277
	16.1 Intermediate survey	
	16.2 Class renewal survey	
17	Semi-submersible cargo ship	277
	17.1 Annual survey	
	17.2 Intermediate survey	
	17.3 Class renewal survey	
18	Diving systems	278
	18.1 Surveys	
19	Pipe laying ship	278
	19.1 Annual survey	
	19.2 Class renewal survey	

Section 9 Ships using Low Flashpoint Liquid or Gas Fuels

1	General	279
	1.1 Application	
2	Annual survey - Hull items	279
	2.1 General	
	2.2 Gas related spaces, fuel preparation and handling rooms and piping	
	2.3 Fuel storage, bunkering and supply systems	
3	Annual survey - Gas fuel machinery items	280
	3.1 Control, monitoring and safety systems	
	3.2 Fuel handling piping, machinery and equipment	
	3.3 Ventilating systems	
	3.4 Hazardous areas	
4	Intermediate survey	280
	4.1 General	
5	Class renewal survey - Hull items	280
	5.1 General	
	5.2 Fuel handling and piping	
	5.3 Fuel valves	
	5.4 Pressure relief valves	
	5.5 Fuel storage tanks	
6	Class renewal survey - Gas fuel machinery items	281
	6.1 Fuel handling equipment	
	6.2 Electrical equipment	
	6.3 Safety systems	

Appendix 1 Oil Tanker Longitudinal Strength Assessment

1	General	282
	1.1	

2	Evaluation of longitudinal strength	282
2.1	Transverse sectional areas	
2.2	Transverse section modulus	
2.3	Calculation criteria of section modulus	
3	Sampling method of thickness measurements	282
3.1	Extent of evaluation	
3.2	Sampling method of thickness measurements	
3.3	Additional measurements	
3.4	Repair methods	

CHAPTER 5

SCOPE OF SURVEYS RELATED TO ADDITIONAL CLASS NOTATIONS

Section 1 General

1	General	287
	1.1	
2	Additional class notations subject to additional surveys	287
	2.1	

Section 2 VeriSTAR and STAR Notations

1	General	289
	1.1 Application	
2	VeriSTAR-HULL SIS	289
	2.1 General	
	2.2 Class renewal survey	
3	STAR-HULL	290
	3.1 General	
	3.2 Class renewal survey	
	3.3 Suspension and withdrawal of the notation	
4	STAR-MACH SIS	291
	4.1 General	
	4.2 Annual audit and confirmatory surveys	
	4.3 Re-approval of the Maintenance Plan	

Section 3 Availability of Machinery

1	General	292
	1.1	
2	Annual survey	292
	2.1	
3	Class renewal survey	292
	3.1	

Section 4 Automated Machinery Systems

1	General	293
	1.1	

2	Annual survey	293
	2.1	
3	Class renewal survey	293
	3.1	

Section 5 Integrated Ship Systems

1	General	294
	1.1	
2	Annual survey	294
	2.1 All notations	
	2.2 Notations SYS-NEQ and SYS-NEQ-1	
	2.3 Notation SYS-COM	
	2.4 Notations SYS-IBS and SYS-IBS-1	
3	Class renewal survey	295
	3.1 All notations	

Section 6 Monitoring Equipment

1	General	296
	1.1 Application	
2	MON-HULL	296
	2.1 Annual and class renewal survey	
3	MON-SHAFT	296
	3.1 Tailshaft survey	
4	MON-ICE L(i) and MON-ICE G	296
	4.1 Annual survey	

Section 7 Pollution Prevention

1	General	297
	1.1 Application	
2	Prevention of sea pollution	297
	2.1 First annual survey	
	2.2 Annual survey	
	2.3 Class renewal survey	
3	Prevention of air pollution	298
	3.1 Annual survey	
	3.2 Class renewal survey	
	3.3 Ultra-low emission vessel (ULEV)	
	3.4 Continuous emission monitoring system (CEMS)	
4	Ship Energy Efficiency Management Plan (SEEMP)	299
	4.1 Intermediate and class renewal surveys	

Section 8 Refrigerating Installations

1	General	300
	1.1	
2	Annual survey	300
	2.1 General	
	2.2 Refrigerating plant	
	2.3 Refrigerated spaces	
	2.4 Instrumentation and safety devices	
	2.5 Notation -AIRCONT	
3	Class renewal survey	301
	3.1 General	
	3.2 Refrigerating plant	
	3.3 Refrigerated spaces	
	3.4 Instrumentation and safety devices	
	3.5 Notation -AIRCONT	

Section 9 Arrangements for Navigation in Ice

1	General	302
	1.1	
2	Class renewal survey	302
	2.1 Thickness measurements	
	2.2 Sea chests	

Section 10 Other Notations

1	General	303
	1.1	
2	STRENGTHBOTTOM	303
	2.1 Dry-docking survey	
3	GRABLOADING and GRAB[X]	303
	3.1 Class renewal survey	
4	SPM	303
	4.1 Annual survey	
	4.2 Class renewal survey	
5	DYNAPOS	303
	5.1 Annual survey	
	5.2 Class renewal survey	
6	VCS	304
	6.1 Annual survey	
	6.2 Class renewal survey	
7	COVENT	305
	7.1 Annual survey	
	7.2 Class renewal survey	

8	CARGOCONTROL	305
	8.1 Annual survey	
	8.2 Class renewal survey	
9	COLD DI, COLD (H tDH, E tDE)	305
	9.1 General	
	9.2 Annual survey	
	9.3 Class renewal survey	
10	COLD CARGO	306
	10.1 General	
	10.2 Annual survey	
	10.3 Class renewal survey	
11	HABITABILITY, COMF-NOISE-SIS, COMF-VIB-SIS, COMF+-SIS, COMF-NOISE-Pax-SIS, COMF-NOISE-Crew-SIS, COMF-VIB-Pax-SIS, COMF-VIB-Crew-SIS	306
	11.1 General	
	11.2 Annual survey	
	11.3 Class renewal survey	
12	Permanent means of access (ACCESS)	307
	12.1 Annual survey, intermediate survey and class renewal survey	
13	Offshore handling systems (OHS)	307
	13.1 Application	
	13.2 Periodical surveys	
14	Helideck (HEL)	307
	14.1 Application	
	14.2 Annual surveys	
15	BATTERY SYSTEM	308
	15.1 General	
	15.2 Annual survey	
	15.3 Class renewal survey	
16	Offshore Access System (OAS)	308
	16.1 Application	
	16.2 Periodical surveys	
17	Chemical, biological, radiological or nuclear hazards	309
	17.1 General	
	17.2 Annual survey	
	17.3 Class renewal survey	
18	ELECTRIC HYBRID	309
	18.1 General	
	18.2 Annual survey	
	18.3 Class renewal survey	
19	CYBER MANAGED and CYBER SECURE	310
	19.1 General	
	19.2 Annual surveys	
	19.3 Intermediate surveys	
	19.4 Class renewal surveys	

20	Heading control	311
	20.1 General	
	20.2 Annual survey	
	20.3 Class renewal survey	
21	Enhanced cargo fire protection on container ships	311
	21.1 General	
	21.2 Annual survey	
	21.3 Class renewal survey	
22	Biological risk control	312
	22.1 General	
	22.2 BIORISK MANAGED	
	22.3 BIORISK SECURED	
23	Hybrid mechanical propulsion	312
	23.1 General	
	23.2 Annual survey	
	23.3 Class renewal survey	
24	Enhanced fire protection	312
	24.1 General	
	24.2 Annual survey	

CHAPTER 6

RETROACTIVE REQUIREMENTS FOR EXISTING SHIPS

Section 1 General

1	General	315
1.1		
1.2	List of retroactive rule requirements	

Section 2 Bulk Carriers, Ore Carriers and Combination Carriers

1	Foremost cargo hold requirements	316
1.1	Application	
1.2	Schedule for compliance	
1.3	Scantlings of the vertically corrugated transverse watertight bulkhead between the two foremost cargo holds	
1.4	Allowable hold loading of the foremost cargo hold with the same hold flooded	
1.5	Damage stability	
2	Loading instruments and loading manuals	317
2.1	Loading instruments	
2.2	Loading manuals	
3	Strength requirements for fore deck fittings and equipment, strength and securing of small hatches on the exposed fore deck	318
3.1	Application and requirements	
3.2	Schedule for compliance	
4	Cargo hatch cover securing arrangements for bulk carriers	318
4.1	Application and requirements	
4.2	Schedule for compliance	
5	Renewal criteria for side shell frames and brackets in single side skin bulk carriers and single side skin OBO carriers	319
5.1	Application and requirements	
5.2	Schedule for compliance	
5.3	Requirements for the gauging of side shell frames and brackets	
6	Hold, ballast and dry space water level detectors	322
6.1	Application and requirements	
6.2	Schedule for compliance	
7	Availability of pumping systems	322
7.1	Application and requirements	
7.2	Schedule for compliance	
8	Restriction from sailing with any hold empty	322
8.1	Application and requirements	

Section 3 Ro-ro Passenger Ships

1	General	323
	1.1 Application	
2	Increased stability and watertight integrity	323
	2.1	

Section 4 Cargo Ships

1	Strength requirements for fore deck fittings and equipment, strength and securing of small hatches on the exposed fore deck	324
	1.1 Application and requirements	
	1.2 Schedule for compliance	
2	Water level detectors on single hold cargo ships other than bulk carriers	324
	2.1 Application and requirements	
	2.2 Schedule for compliance	

Section 5 Ships with Ice Classes

1	General	326
	1.1 Application	
2	Requirements to maintain ice classes	326
	2.1	
3	Ice class draught marking	326
	3.1	

Appendix 1 Technical Retroactive Requirements for Bulk Carriers and Other Types of Ships

1	General	327
	1.1	
2	Evaluation of scantlings of the transverse watertight vertically corrugated bulkheads between the two foremost cargo holds	327
	2.1 Application and definitions	
	2.2 Load model	
	2.3 Bending moment and shear force in the bulkhead corrugations	
	2.4 Strength criteria	
	2.5 Local details	
	2.6 Steel renewal	
3	Guidance on renewal/reinforcement of the transverse watertight vertically corrugated bulkhead between the two foremost cargo holds	334
	3.1	

4	Evaluation of allowable hold loading of the foremost cargo hold with the same cargo hold flooded	336
<hr/>		
	4.1 Application and definitions	
	4.2 Load model	
	4.3 Shear capacity of the double bottom of the foremost cargo hold	
	4.4 Allowable hold loading	
5	Renewal criteria for side shell frames and brackets in single side skin bulk carriers and single side skin OBO carriers not built in accordance with Part II, Chapter 8, Section 8-03 of the 1st April 1998 edition of the Rules or subsequent editions	339
<hr/>		
	5.1 Application and symbols	
	5.2 Ice strengthened ships	
	5.3 Criteria for renewal	
	5.4 Other measures	
	5.5 Strength check criteria	
6	Cargo hatch cover securing arrangements for bulk carriers not built in accordance with Pt B, Ch 9, Sec 7	346
<hr/>		
	6.1 Application	
	6.2 Securing devices	
	6.3 Stoppers	
	6.4 Materials and welding	
7	Guidance on loading/unloading sequences	347
<hr/>		
	7.1	
8	Water level detectors on single hold cargo ships other than bulk carriers	347
<hr/>		
	8.1 Application	
	8.2 Water level detectors	

Part A
Classification and Surveys

Chapter 1

**PRINCIPLES OF CLASSIFICATION
AND CLASS NOTATIONS**

SECTION 1 GENERAL PRINCIPLES OF CLASSIFICATION

SECTION 2 CLASSIFICATION NOTATIONS

**APPENDIX 1 NOTATIONS ASSIGNED ACCORDING TO EDITIONS OF THE
RULES FORMER TO JUNE 2000 EDITION**

SECTION 1

GENERAL PRINCIPLES OF CLASSIFICATION

1 Principles of classification

1.1 Purpose of the Rules

1.1.1 The Rules published by the Society give the requirements for the assignment and the maintenance of classification for seagoing ships.

Note 1: The general conditions of classification are laid down in the Marine & Offshore General Conditions.

1.1.2 The application criteria of the different parts of the present Rules are the following:

- Part A - Classification and Surveys applies to all ships.
- Part B - Hull and Stability, Part C - Machinery and Systems, Part E and Part E - Service Notations apply to seagoing ships whose hull is of welded steel construction. Where necessary, the extent of application is more precisely defined in each chapter of these parts of the Rules.
- Part F - Additional Class Notations applies, at the request of the Interested Party, to all ships.

The classification of ships other than those dealt with in the above-mentioned Parts B, C, D, E and F is covered by specific Rules published by the Society.

1.1.3 Classification of diving systems

The classification of the diving systems is covered by Rule Note NR610, Rules for the Classification of Diving Systems.

Unless otherwise specified, the provisions of the present Rules apply, "diving system" being to be understood when reference is made to "ship".

In case of discrepancy between the requirements of the present Rules and those of NR610, the latter prevail.

1.2 General definitions

1.2.1 The following general definitions are used in these Rules:

- Society means the Classification Society with which the ship is classed
- Rules means these Rules for the Classification of Ships and documents issued by the Society serving the same purpose
- Surveyor means technical staff acting on behalf of the Society to perform tasks in relation to classification and survey duties
- Survey means an intervention by the Surveyor for assignment or maintenance of class as defined in Part A, Chapter 2, or interventions by the Surveyor within the limits of the tasks delegated by the Administrations
- Administration means the Government of the State whose flag the ship is entitled to fly or the State under whose authority the ship is operating in the specific case

- Interested Party means a party, other than the Society, having responsibility for the classification of the ship, such as the Owners of a ship and his representatives, or the Shipbuilder, or the Engine Builder, or the Supplier of parts to be tested
- Owner means the Registered Owner or the Disponent Owner or the Manager or any other party having the responsibility to keep the ship seaworthy, having particular regard to the provisions relating to the maintenance of class laid down in Part A, Chapter 2
- Approval means the review by the Society of documents, procedures or other items related to classification, verifying solely their compliance with the relevant Rules requirements, or other referential where requested
- Essential service is intended to mean a service necessary for a ship to proceed at sea, be steered or manoeuvred, or undertake activities connected with its operation, and for the safety of life, as far as class is concerned.

1.2.2 Definition of date of "contract for construction":

The date of "contract for construction" of a ship is the date on which the contract to build the ship is signed between the Owner and the Shipbuilder. This date is normally to be declared to the Society by the Interested Party applying for the assignment of class to a new ship. For ships "contracted for construction" on or after 1st April 2006, this date and the construction numbers (i.e. hull numbers) of all the ships included in the contract, are to be declared to the Society by the Interested Party applying for the assignment of class to a new ship.

The date of "contract of construction" of a series of ships, including specified optional ships for which the option is ultimately exercised, is the date on which the contract to build the series is signed between the Owner and the Shipbuilder.

For the purpose of this definition, ships built under a single contract for construction are considered a "series of ships" if they are built to the same approved plans for classification purposes. However, ships within a series may have design alterations from the original design provided:

- Such alterations do not affect matters related to classification, or
- If the alterations are subject to classification requirements, these alterations are to comply with the classification requirements in effect on the date on which the alterations are contracted between the prospective Owner and the Shipbuilder or, in the absence of the alteration contract, comply with the classification requirements in effect on the date on which the alterations are submitted to the Society for approval.

The optional ships will be considered part of the same series of ships if the option is exercised not later than 1 year after the contract to build the series was signed.

If a contract for construction is later amended to include additional ships or additional options, the date of “contract for construction” for such ships is the date on which the amendment to the contract is signed between the Owner and the Shipbuilder. The amendment to the contract is to be considered as a “new contract” to which the above applies.

If a contract for construction is amended to change the ship type, the date of “contract for construction” of this modified ship or ships, is the date on which the revised contract or new contract is signed between the Owner, or Owners, and the shipbuilder.

1.3 Meaning of classification, scope and limits

1.3.1 The classification process consists of:

- the development of Rules, guidance notes and other documents relevant to the ship, structure, material, equipment, machinery and other items covered by such documents
- the review of plans and calculations and the surveys, checks and tests intended to demonstrate that the ship meets the Rules (refer to Ch 2, Sec 1)
- the assignment of class (see Ch 2, Sec 1) and issue of a Certificate of Classification, where compliance with the above Rules is found
- the periodical, occasional and class renewal surveys performed to record that the ship in service meets the conditions for maintenance of class (see Ch 2, Sec 2).

1.3.2 The Rules, surveys performed, reports, certificates and other documents issued by the Society, are in no way intended to replace or alleviate the duties and responsibilities of other parties such as Administrations, Designers, Shipbuilders, Manufacturers, Repairers, Suppliers, Contractors or Sub-contractors, actual or prospective Owners or Operators, Charterers, Brokers, Cargo-owners and Underwriters.

The activities of such parties which fall outside the scope of the classification as set out in the Rules, such as design, engineering, manufacturing, operating alternatives, choice of type and power of machinery and equipment, number and qualification of crew or operating personnel, lines of the ship, trim, hull vibrations, spare parts including their number, location and fastening arrangements, life-saving appliances, and maintenance equipment, remain therefore the responsibility of those parties, even if these matters may be given consideration for classification according to the type of ship or additional class notation assigned.

1.3.3 Unless otherwise specified, the Rules do not deal with structures, pressure vessels, machinery and equipment which are not permanently installed and used solely for operational activities such as dredging or heavy load lifting, workshops or welding equipment, except for their effect on the classification-related matters, as declared by the Interested Party, such as fire protection and ship’s general strength.

During periods of construction, modification or repair, the unit is solely under the responsibility of the builder or the repair yard. As an example, the builder or repair yard is to ensure that the construction, modification or repair activities are compatible with the design strength of the ship and that no permanent deformations are sustained.

Note 1: Refer to [3.3] as regards the Owner’s responsibility for maintenance and operation of the ship in relation to the maintenance of class.

1.3.4 The class assigned to a ship by the Society following its interventions is embodied in a Certificate of Classification and noted in the Register of ships.

At a certain date the class of a ship is maintained or regular when no surveys are overdue, when the conditions for suspension of class are not met and when the class is not withdrawn nor suspended. Otherwise the class is irregular. Attention is drawn on the fact that a ship holding a valid Certificate of Classification may be in an irregular class position.

1.4 Request for services

1.4.1 Requests for interventions by the Society, such as surveys during construction, surveys of ships in service, tests, etc., are in principle to be submitted in writing and signed by the Interested Party. Such request implies that the applicant will abide by all the relevant requirements of the Rules, including the Marine & Offshore General Conditions.

The Society reserves the right to refuse or withdraw the class of any ship for which any applicable requirement of the Rules is not complied with.

1.5 Register of ships

1.5.1 A Register of Ships is published periodically by the Society. This publication, which is updated by the Society, contains the names of ships which have received the Certificate of Classification, as well as particulars of the class assigned and information concerning each ship.

2 Rules

2.1 Effective date

2.1.1 The effective date of entry into force of any amendments to the Rules is indicated on the inside front page of the Rules or in the relevant Section.

2.1.2 In principle, the applicable Rules for assignment of class to a new ship are those in force at the date of contract for construction.

2.1.3 Special consideration may be given to applying new or modified rule requirements which entered into force subsequent to the date of contract for construction, at the discretion of the Society and in the following cases:

- when a justified written request is received from the party applying for classification
- when the keel is not yet laid and more than one year has elapsed since the contract for construction was signed
- where it is intended to use existing previously approved plans for a new contract.

2.1.4 The above procedures for application of the Rules are, in principle, also applicable to existing ships in the case of major conversions and, in the case of alterations, to the altered parts of the ship.

2.1.5 The rule requirements related to assignment, maintenance and withdrawal of the class of ships already in operation, as detailed in Part A, Chapter 2 to Part A, Chapter 5, are applicable from the date of their entry into force.

2.2 Equivalence

2.2.1 The Society may consider the acceptance of alternatives to these Rules, provided that they are deemed to be equivalent to the Rules to the satisfaction to the Society.

2.2.2 If deemed necessary, the Society may require that engineering analysis, assessment and approval of the alternative design and arrangement be carried out in accordance with IMO MSC.1/Circ.1002 as amended, IMO MSC/Circ.1212 as amended and IMO MSC.1/Circ.1455 as amended, as applicable.

2.3 Novel features

2.3.1 The Society may consider the classification of ships based on or applying novel design principles or features, to which the Rules are not directly applicable, on the basis of experiments, calculations or other supporting information provided to the Society. Specific limitations may then be indicated on a memoranda.

2.4 Disagreement and appeal

2.4.1 Any technical disagreement with the Surveyor in connection with the performance of his duties should be raised by the Interested Party as soon as possible.

The Interested Party may appeal in writing to the Society, which will subsequently consider the matter and announce its decision according to its established procedure.

3 Duties of the Interested Parties

3.1 International and national regulations

3.1.1 The classification of a ship does not relieve the Interested Party from compliance with any requirements issued by Administrations.

Note 1: Attention is drawn on the prohibition of asbestos on-board ships (new ships, modified parts of existing ships) and other National Regulations, as applicable.

3.2 Surveyor's intervention

3.2.1 Surveyors are to be given free access at all times to ships which are classed or being classed, shipyards and works, to carry out their interventions within the scope of assignment or maintenance of class, or within the scope of interventions carried out on behalf of Administrations, when so delegated.

Free access is also to be given to auditors accompanying the Surveyors of the Society within the scope of the audits as required in pursuance of the Society's internal Quality System or as required by external organizations.

3.2.2 Interested Parties are to take the necessary measures for the Surveyors' inspections and testing to be carried out safely. Interested Parties - irrespective of the nature of the service provided by the Surveyors of the Society or others acting on its behalf - assume with respect to such Surveyors all the responsibility of an employer for his workforce such as to meet the provisions of applicable legislation. As a rule, the Surveyor is to be constantly accompanied during surveys by personnel of the Interested Party.

Interested Parties are to inform promptly the Surveyor of defects or problems in relation to class.

Refer also to Ch 2, Sec 2, [2.5] to Ch 2, Sec 2, [2.9].

3.2.3 The Certificate of Classification and/or other documents issued by the Society remain the property of the Society. All certificates and documents necessary to the Surveyor's interventions are to be made available by the Interested Party to the Surveyor on request.

3.2.4 During the phases of ship design and construction, due consideration should be given to rule requirements in respect of all necessary arrangements for access to spaces and structures with a view to carrying out class surveys. Arrangements of a special nature are to be brought to the attention of the Society.

3.3 Operation and maintenance of ships

3.3.1 The classification of a ship is based on the understanding that the ship is loaded and operated in a proper manner by competent and qualified crew or operating personnel according to the environmental, loading, operating and other criteria on which classification is based.

In particular, it will be assumed that the draught of the ship in operating conditions will not exceed that corresponding to the freeboard assigned or the maximum approved for the classification, that the ship will be properly loaded taking into account both its stability and the stresses imposed on its structures and that cargoes will be properly stowed and suitably secured and that the speed and course of the ship are adapted to the prevailing sea and weather conditions according to the normal prudent seamanship.

3.3.2 Ships are to be maintained at all times, at the diligence of the Owners, in proper condition complying with international safety and pollution prevention regulations.

3.3.3 Any document issued by the Society in relation to its interventions reflects the condition of the ship as found at the time and within the scope of the survey. It is the Interested Party's responsibility to ensure proper maintenance of the ship until the next survey required by the Rules. It is the duty of the Interested Party to inform the Surveyor when he boards the ship of any events or circumstances affecting the class.

3.4 Flag and Port State Control inspections

3.4.1 Where defects are found further to an inspection by an Administration in pursuance of Port State Control or similar programmes, Owners are to:

- inform the Society about any deficiency related to the class of the ship or to the statutory certificates issued by the Society on behalf of the flag Administration, and provide its action plan for rectification of these deficiencies. It will be verified by next attending Surveyors that deficiencies are rectified and/or that the necessary repair work is carried out within due time.
- immediately report the outcome of this inspection to the Society when the ship is detained, and ask to the Society to perform an occasional survey.

3.5 Use of measuring equipment and of service suppliers

3.5.1 General

Firms providing services on behalf of the Interested Party, such as measurements, tests and servicing of safety systems and equipment, the results of which may form the basis for the Surveyor's decisions, are subject to the acceptance of the Society, as deemed necessary.

The equipment used during tests and inspections in workshops, shipyards and on board ships, the results of which may form the basis for the Surveyor's decisions, is to be customary for the checks to be performed. Firms are to individually identify and calibrate to a national or international standard each piece of such equipment.

Note 1: Refer to Rule Note NR 533 Approval of Service Suppliers.

3.5.2 Simple measuring equipment

The Surveyor may accept simple measuring equipment (e.g. rulers, tape measures, weld gauges, micrometers) without individual identification or confirmation of calibration, provided it is of standard commercial design, properly maintained and periodically compared with other similar equipment or test pieces.

3.5.3 Shipboard measuring equipment

The Surveyor may accept measuring equipment fitted on board a ship (e.g. pressure, temperature or rpm gauges and meters) and used in examination of shipboard machinery and/or equipment based either on calibration records or comparison of readings with multiple instruments.

3.6 Spare parts

3.6.1 It is the Owner's responsibility to decide whether and which spare parts are to be carried on board.

3.6.2 As spare parts are outside the scope of classification, the Surveyor will not check that they are kept on board, maintained in a satisfactory condition, or suitably protected and lashed.

However, in the case of repairs or replacement, the spare parts used are to meet the requirements of the Rules as far as practicable; refer to Ch 2, Sec 2, [6.4.2].

3.7 Quality system audits

3.7.1 Attention is drawn to the possibility that auditors external to the Society may attend surveys and audits carried out by the Society and that this attendance shall not be obstructed.

4 Application of statutory requirements by the Society

4.1 International and national regulations

4.1.1 Where requirements of International Conventions, such as SOLAS, ILLC, MARPOL, ILO or of IMO Assembly Resolutions, are quoted as excerpts, they are printed in italic type replacing the word "Administration" with "Society".

These requirements are quoted for ease of reference.

4.1.2 When authorised by the Administration concerned, the Society will act on its behalf within the limits of such authorisation. In this respect, the Society will take into account the relevant national requirements, survey the ship, report and issue or contribute to the issue of the corresponding certificates.

The above surveys do not fall within the scope of the classification of ships, even though their scope may overlap in part and may be carried out concurrently with surveys for assignment or maintenance of class.

4.1.3 In the case of a discrepancy between the provisions of the applicable international and national regulations and those of the Rules, normally, the former take precedence. However, the Society reserves the right to call for the necessary adaptation to preserve the intention of the Rules or to apply the provisions of [1.4.1].

4.1.4 In statutory matters, when authorized by the Administration concerned and acting on its behalf, the Society applies the available IACS Unified Interpretations (UIs), unless provided with written instruction to apply a different interpretation by the flag Administration.

SECTION 2

CLASSIFICATION NOTATIONS

1 General

1.1 Purpose of the classification notations

1.1.1 The classification notations give the scope according to which the class of the ship has been based and refer to the specific rule requirements which are to be complied with for their assignment. In particular, the classification notations are assigned according to the type, service and navigation of the ship and other criteria which have been provided by the Interested Party, when applying for classification.

The Society may change the classification notations at any time, when the information available shows that the requested or already assigned notations are not suitable for the intended service, navigation and any other criteria taken into account for classification.

Note 1: Reference should be made to Ch 1, Sec 1, [1.3] on the limits of classification and its meaning.

1.1.2 The classification notations assigned to a ship are indicated on the Certificate of Classification, as well as in the Register of Ships published by the Society.

1.1.3 The classification notations assigned to ships and units, other than those covered in Parts B, C, D, E and F, which are to comply with specific Rules published by the Society are given in Ch 1, App 1.

1.1.4 The classification notations applicable to existing ships conform to the Rules of the Society in force at the date of assignment of class, as indicated in Ch 2, Sec 1. However, the classification notations of existing ships may be updated according to the current Rules, as far as applicable.

1.1.5 The classification notations applicable to diving systems are defined in NR610, Rules for the Classification of Diving Systems. The requirements in [1.2] and from Articles [2] to [7] are not applicable to diving systems.

The diving systems are assigned with one of the service notations defined in [8].

1.2 Types of notations assigned

1.2.1 The types of classification notations assigned to a ship are the following:

- class symbol
- construction marks
- service notations with additional service features, as applicable
- navigation notations

e) operating area notations (optional)

f) additional class notations (optional).

The different classification notations and their conditions of assignment are listed in Articles [2] to [6], according to their types.

1.2.2 As an example, the classification notations assigned to a ship may be as follows (the kind of notation shown in brackets does not form part of the classification notation indicated in the Register of Ships and on the Certificate of Classification):

I ⚡ **HULL** ⚡ **MACH**

(class symbol, construction marks)

oil tanker chemical tanker ESP-Flash point > 60°C

(service notation and additional service features)

unrestricted navigation

(navigation notation)

⚡ **SYS-IBS-1**

(additional class notation).

2 Class symbol

2.1 General

2.1.1 The class symbol expresses the degree of compliance of the ship with the rule requirements as regards its construction and maintenance. There is one class symbol, which is compulsory for every classed ship.

2.1.2 The class symbol **I** is assigned to ships built in accordance with the requirements of the Rules or other rules recognised as equivalent, and maintained in a condition considered satisfactory by the Society.

The period of class (or interval between class renewal surveys) assigned to class symbol **I** ships is maximum 5 years, see Ch 2, Sec 2, [4].

Note 1: The class symbol **I** is to be understood as being the highest class granted by the Society.

2.1.3 The class symbol **II** is assigned to ships which do not meet all requirements for class symbol **I**, but are deemed acceptable to be entered into the Register of Ships.

The period of class assigned to class symbol **II** ships is maximum 3 years, see Ch 2, Sec 2, [4].

2.1.4 Except for special cases, class is assigned to a ship only when the hull, propulsion and auxiliary machinery installations, and equipment providing essential services have all been reviewed in relation to the requirements of the Rules.

3 Construction marks

3.1 General

3.1.1 The construction mark identifies the procedure under which the ship and its main equipment or arrangements have been surveyed for initial assignment of the class. The procedures under which the ship is assigned one of the construction marks are detailed in Ch 2, Sec 1.

3.1.2 One of the construction marks defined below is assigned separately to the hull of the ship and its appendages, to the machinery installation, and to some installations for which an additional classification notation (see [6] below) is assigned.


The construction mark is placed before the symbol **HULL** for the hull, before the symbol **MACH** for the machinery installations, and before the additional class notation granted, when such a notation is eligible for a construction mark.


If the ship has no machinery installations covered by classification, the symbol **MACH** is not granted and the construction mark will be only placed before the symbol **HULL**.


Note 1: for ships assigned with the service notation **yacht** or **charter yacht** and having a length less than 24 m may, see additional requirements defined in NR500.

3.1.3 The construction marks refer to the original condition of the ship. However, the Society may change the construction mark where the ship is subjected to repairs, conversion or alterations.

3.2 List of construction marks

3.2.1 The mark  is assigned to the relevant part of the ship, when it has been surveyed by the Society during its construction in compliance with the new building procedure detailed in Ch 2, Sec 1, [2.1], or when it is changing class from an IACS Society at ship's delivery or when class is being added to an IACS Society's class at ship's delivery in accordance with specific procedures.

3.2.2 The mark  is assigned to the relevant part of the ship, when the latter is classed after construction in compliance with the procedure detailed in Ch 2, Sec 1, [3.2] and it is changing class from an IACS Society at the time of the admission to class.

3.2.3 The mark  is assigned to the relevant part of the ship, where the procedure for the assignment of classification is other than those detailed in [3.2.1] and [3.2.2], but however deemed acceptable.

4 Service notations and corresponding additional service features

4.1 General

4.1.1 The service notations define the type and/or service of the ship which have been considered for its classification, according to the request for classification signed by the Interested Party. At least one service notation is to be assigned to every classed ship.

Note 1: The service notations applicable to existing ships conform to the Rules of the Society in force at the date of assignment of class. However, the service notations of existing ships may be updated according to the current Rules, as far as applicable, at the request of the Interested Party.

4.1.2 The assignment of any service notation to a new ship is subject to compliance with the general rule requirements laid down in Part B and Part C of the present Rules and in NR216 Materials and Welding, and, for some service notations, with the additional requirements laid down in the corresponding Chapter of Part D and Part E.

Note 1: For a service notation defined in a Rule Note, the assignment of this service notation to a new ship is subject to compliance with the general rule requirements laid down in Part B and Part C of the present Rules and in NR216 Materials and Welding, and with the additional requirements laid down in the relevant Rule Note and, if relevant, with the requirements laid down in:

- NR600 Hull Structure and Arrangement for the Classification of Cargo Ships less than 65 m and Non Cargo Ships less than 90 m
- NR566 Hull Arrangement, Stability and Systems for Ships less than 500 GT.

4.1.3 A ship may be assigned several different service notations. In such case, the specific rule requirements applicable to each service notation are to be complied with. However, if there is any conflict in the application of the requirements applicable to different service notations, the Society reserves the right to apply the most appropriate requirements or to refuse the assignment of one of the requested service notations.

4.1.4 A service notation may be completed by one or more additional service features, giving further precision regarding the type of service of the ship, for which specific rule requirements are applied.

4.1.5 The different service notations which may be assigned to a ship are listed in [4.2] to [4.17], according to the category to which they belong. These service notations are also listed in Tab 1 and Tab 2, where the correspondence between the service notation assigned by the Society and the type of ship defined by the International Conventions is also given for information.

As a rule, all notations in [4.2], [4.3], [4.4] and [4.5] are only to be assigned to self-propelled units.

Table 1 : List of service notations and additional service features

Service notation [ref. in Part A] Additional service feature	Reference Reference	Corresponding type of ship according to Conventions and/or Codes
Anchor handling [4.8.2]	Part E, Chapter 2	Cargo ship (SOLAS, Reg I/2(g))
Asphalt carrier [4.4.3]	Part D, Chapter 7	
Barge [4.10.1] tug combined type of cargo (1)	Part D, Chapter 14 Pt E, Ch 1, Sec 4 –	
Bulk carrier [4.3] ESP BC-A or BC-B or BC-C nonhomload CSR GRAB [X] CPS(WBT) heavycargo [AREA1, X1 kN/m ² - ...] (2) (3) (4) (5)	Part D, Chapter 4 Part D, Chapter 4 SOLAS, Reg IX/1.6 SOLAS, Reg XI-1/2 Part D, Chapter 4 – NR606 (10) NR522 NR606 (10) NR522, Ch 12, Sec 1 NR530 Pt B, Ch 5, Sec 6	Cargo ship (SOLAS, Reg I/2(g)) Bulk carrier (SOLAS, Reg XII/1)
Chemical tanker [4.4.4] ESP IMO Type 1, IMO Type 2, IMO Type 3 type of cargo (1)	Part D, Chapter 8	Chemical tanker (SOLAS, Reg.II-2/3.11, Reg.VII /8.2) Chemical tanker (MARPOL Annex II, Reg 1/16.1) when noxious liquid substances are loaded
Combination carrier/OBO ESP [4.3.4]	Part D, Chapter 6	Combination carrier (SOLAS, Reg II-2/3.14) Tanker (SOLAS, Reg I/2(h)) Bulk carrier (SOLAS, Reg IX/1.6, Reg XII/1) Oil tanker - Combination carrier (MARPOL Annex I, Reg I/1.8)
Combination carrier/OOC ESP [4.3.5]	Part D, Chapter 6	Combination carrier (SOLAS, Reg II-2/3.14) Tanker (SOLAS, Reg I/2(h)) Bulk carrier (SOLAS, Reg IX/1.6, Reg XII/1) Oil tanker - Combination carrier (MARPOL Annex I, Reg I/1.8)
Compressed natural gas carrier [4.16.5]	NR517	
Container ship [4.2.6] WhiSp1 or WhiSp2	Part D, Chapter 2 NR583	Cargo ship (SOLAS, Reg I/2(g))
Crew boat [4.16.4]	NR490	
Deck ship [4.2.8]	–	Cargo ship (SOLAS, Reg I/2(g))
Diving support-integrated [4.8.5] Diving support-capable [4.8.5] Diving support-portable [4.8.5] DD or SD	Part E, Chapter 7 –	
Dredger [4.6.2]	Part D, Chapter 13	Cargo ship (SOLAS, Reg I/2(g))
Escort tug [4.7.4] barge combined (design bollard pull = $[T_{BP}/9,81]$ t) (design maximum braking force = $[T_{X,MAX}/9,81]$ t) (design maximum escort speed = $[V_{MAX}]$ kN) (design maximum steering force = $[T_{V,MAX}/9,81]$ t) (standardized design bollard pull = $[T_{BP}/9,81]$ t)	Part E, Chapter 1 Pt E, Ch 1, Sec 4 Pt E, Ch 1, Sec 1 Pt E, Ch 1, Sec 1 Pt E, Ch 1, Sec 1 Pt E, Ch 1, Sec 1 Pt E, Ch 1, Sec 1	Cargo ship (SOLAS, Reg I/2(g))

Service notation [ref. in Part A] Additional service feature	Reference Reference	Corresponding type of ship according to Conventions and/or Codes
Fire-fighting [4.8.3] 1, 2, 3 or E water spraying	Part E, Chapter 4 Pt E, Ch 4, Sec 3 Pt E, Ch 4, Sec 4	Cargo ship (SOLAS, Reg I/2(g))
Fishing vessel [4.11.1] F ED TORRE	Part D, Chapter 15 Pt D, Ch 15, Sec 6 European Directive 97/70/EC as amended Torremolinos International Convention for the Safety of Fishing Vessels as amended	Fishing vessel (SOLAS, Reg I/2(ii)). To be noted that SOLAS Convention does not apply to such ships
Floating dock [4.10.5]	NR475	
FLS tanker [4.4.7] flash point > 60°C type of cargo (1)	Part D, Chapter 7 Part D, Chapter 7	Tanker (SOLAS, Reg I/2(h)) NLS Tanker (MARPOL, Annex II, Reg 1/16.2), when noxious liquid substances are loaded
FSRU [4.16.9] FSU-LNG [4.16.9] ([cargo type], [ship type], [P _{design}], [T _{min}])	NR645 NR645 –	
General cargo ship [4.2.2] equipped for carriage of containers nonhomload (3) occasional dry bulk cargo heavycargo [AREA1, X1 kN/m ² - ...]	– Part D, Chapter 2 Pt D, Ch 4, Sec 3 IMO Res.MSC 277(85) para. 1.6 and 1.7 Pt B, Ch 5, Sec 6	Cargo ship (SOLAS, Reg I/2(g))
Hopper dredger, Hopper unit [4.6.2]	Part D, Chapter 13	Cargo ship (SOLAS, Reg I/2(g))
HSC, HSC-CAT A, HSC-CAT B [4.12.1] (6)	NR396 UNITAS	High-speed craft (SOLAS, Chapter X), 2000 HSC Code
Icebreaker z [4.14]	NR527	z is equal to 1, 2, 3, 4, 5, 6 or 7
Launch, Seagoing launch [4.16.2]	NR600 NR566	(non-convention ship)
Light ship [4.12.2] (6)	Part B and Part C or NR566, and NR396, Chapter 3 and Chapter 6	
Liquefied gas carrier [4.4.5] ([cargo type], [ship type], [P _{design}], [T _{min}]) BOG-refiquefaction LNG-subcooling REGAS STL-SPM	Part D, Chapter 9 – Pt D, Ch 9, Sec 1, [7] Pt D, Ch 9, Sec 1, [7] NR645, Sec 10 Pt D, Ch 9, Sec 1, [8]	Tanker (SOLAS, Reg I/2(h)) Gas carrier (SOLAS, Reg II-1/3.20, Reg II-2/3.25, Reg VII /11.2)
Liquefied gas carrier - FSRU [4.16.9] Liquefied gas carrier - FSU [4.16.9] ([cargo type], [ship type], [P _{design}], [T _{min}])	NR645 NR645 –	
Livestock carrier [4.2.7]	Part D, Chapter 3	Cargo ship (SOLAS, Reg I/2(g))
LNG bunkering ship [4.4.6] RE Initial-CD IG-Supply BOG ([cargo type], [ship type], [P _{design}], [T _{min}])	NR620 NR620 NR620 NR620 NR620 –	Tanker (SOLAS, Reg I/2(h)) Gas carrier (SOLAS, Reg II-1/3.20, Reg II-2/3.25, Reg VII /11.2)

Service notation [ref. in Part A] Additional service feature	Reference Reference	Corresponding type of ship according to Conventions and/or Codes
Offshore construction barge () [4.9.2]	(11)	
Offshore support vessel () [4.9.4]	(11)	
Offshore construction vessel () [4.9.3]	(11)	
Oil recovery [4.8.4] OILTREAT SECOND-LINE	Part E, Chapter 5	
Oil storage service [4.4.10]	–	
Oil tanker [4.4.2] ESP flash point > 60°C asphalt carrier CSR CPS(WBT) (5)	Part D, Chapter 7 Part D, Chapter 7 SOLAS, Reg II-1/2.22 SOLAS, Reg XI-1/2 Part D, Chapter 7 Part D, Chapter 7 NR606 (10) NR523 NR530	Tanker (SOLAS, Reg I/2(h)) Oil tanker (MARPOL Annex I, Reg I/1.5)
OPV [4.16.7]	Part D, Chapter 16	
Ore carrier ESP [4.3.3]	Part D, Chapter 5	Cargo ship (SOLAS, Reg I/2(g)) Bulk carrier (SOLAS, Reg IX/1.6, Reg XII/1)
Passenger ship [4.5.2] ≤ 36 passengers SRTP	Part D, Chapter 11 Part D, Chapter 11	Passenger ship (SOLAS, Reg. I/2(f))
PCT carrier [4.2.4]	Part D, Chapter 1	Cargo ship (SOLAS, Reg I/2(g))
Pontoon, Pontoon - crane [4.10.2]	Part D, Chapter 14	
Refrigerated cargo ship [4.2.5] equipped for carriage of containers	(7) Part D, Chapter 2	Cargo ship (SOLAS, Reg I/2(g))
Ro-ro cargo ship [4.2.3] equipped for carriage of containers	Part D, Chapter 1 Part D, Chapter 2	Cargo ship (SOLAS, Reg I/2(g))
Ro-ro passenger ship [4.5.3] ≤ 36 passengers SRTP	Part D, Chapter 12 Part D, Chapter 12	Passenger ship (SOLAS, Reg. I/2(f)) Ro-ro passenger ship (SOLAS, Reg II-2/3.42)
Salvage tug [4.7.3] barge combined (design bollard pull = $[T_{BP}/9,81]$ t) (standardized design bollard pull = $[T_{BP}/9,81]$ t)	Part E, Chapter 1 Pt E, Ch 1, Sec 4 Pt E, Ch 1, Sec 1 Pt E, Ch 1, Sec 1	Cargo ship (SOLAS, Reg I/2(g))
Self-unloading bulk carrier ESP [4.3.6] heavycargo [AREA1, X1 kN/m ² - ...] nonhomload (3)	Part D, Chapter 4 Pt B, Ch 5, Sec 6 –	Cargo ship (SOLAS, Reg I/2(g)) Bulk carrier (SOLAS, Reg IX/1.6, Reg XII/1)
Semi-submersible cargo ship [4.16.8] heavycargo [AREA1, X1 kN/m ² - ...]	Part E, Chapter 9 Pt B, Ch 5, Sec 6	Cargo ship (SOLAS, Reg I/2(g))
Special service [4.16.1] (6)	(8)	
Split hopper dredger, Split hopper unit [4.6.2]	Part D, Chapter 13	Cargo ship (SOLAS, Reg I/2(g))
Tanker [4.4.8] (1) type of cargo	Part D, Chapter 10	Cargo ship (SOLAS, Reg I/2(g))

Service notation [ref. in Part A]	Reference	Corresponding type of ship according to Conventions and/or Codes
Additional service feature	Reference	
Tug [4.7.2]	Part E, Chapter 1	Cargo ship (SOLAS, Reg I/2(g))
barge combined (design bollard pull = $[T_{BP}/9,81]$ t) (standardized design bollard pull = $[T_{BP}/9,81]$ t)	Pt E, Ch 1, Sec 4 Pt E, Ch 1, Sec 1 Pt E, Ch 1, Sec 1	
Wind farms service ship - Xi [4.16.6]	NR589	
X = S, M or L ; i = 0, 1 or 2		
Yacht, Charter yacht [4.16.3]	NR500	
motor or sailing	NR500	
S or C or A or W (9)	NR500	
OTHER ADDITIONAL SERVICE FEATURES		Remarks
ammoniafuel [4.13.1]	NR671	Service feature to be completed by one of the following notations: singlefuel , dualfuel Service feature may be completed by one of the following notations: -aux , -prop .
LNGfuel or CNGfuel or LFPfuel [4.13.1]	NR529 or Part D, Chapter 9	
LPGfuel [4.13.1]	NI647 or Part D, Chapter 9	
methanolfuel [4.13.1]	NR670	
assisted propulsion [4.10.4]	–	
CBM or [CBM] [4.17.9]	–	
CPS(WBT) [4.17.6] (5)	NR530	
ESA [4.15.1]	NR592	
fuelcell [4.13.2]	NI547 or Part D, Chapter 9	
heavycargo [AREA1, X1 kN/m ² - ...] [4.17.4]	Pt B, Ch 5, Sec 6	
no propulsion [4.10.3]	Part D, Chapter 14	Any non-propelled units other than barge or pontoon
POLAR CAT-A or POLAR CAT-B or POLAR CAT-C [4.17.3]	NR527	Mandatory for ships operating in polar waters (as defined in SOLAS and MARPOL)
POWERGEN(OIL) or POWERGEN(LNG/NG) or POWERGEN(DUALFUEL) [4.17.7]	NR656	
SMART() [4.17.8]	NR675	Service feature to be completed between brackets by at least one of the following notations: H1 or H2 , M1 or M2 , N1 or N2
SPxxx [4.17.1]	–	
SW-Registry [4.17.5]	Pt C, Ch 3, Sec 3	
Tier III [4.17.2]	–	

- (1) For ships intended to carry only one type of cargo.
- (2) Additional indications: for **BC-A**: (holds a, b, ..., ... may be empty) and (**Block-loading**) if applicable; for **BC-A** or **BC-B** and if x.y is less than 3 t/m³: (**maximum cargo density x.y t/m³**); for **BC-A**, **BC-B** or **BC-C**: (**no MP**) if applicable.
- (3) Completed with indication of the different maximum loads allowed in each hold and which holds may be empty, if appropriate.
- (4) Mandatory as an additional service feature for bulk carriers **CSR BC-A** or **CSR BC-B**.
- (5) Mandatory for ships assigned with additional service feature **CSR** and contracted for construction on or after 8 December 2006.
- (6) The type of service may be specified after the service notation, i.e. **light ship/fast passenger vessel**, **light ship/fast cargo vessel**, **light ship/fast patrol vessel**.
- (7) No additional requirements are specified in Part D for this service notation; however requirements of Part F, Chapter 7 for the assignment of the additional class notation **REF-CARGO** are to be applied.
- (8) These ships are considered on a case by case basis by the Society according to their type of service.
- (9) Corresponding to hull material as defined in NR500.
- (10) Bulk carriers and Oil tankers assigned with the additional service feature **CSR** contracted for new construction on or after 1 July 2015 are to comply with the requirements of NR606 Common Structural Rules for Bulk Carriers and Oil Tankers.
- (11) These notations are not linked with technical requirements but are always completed by other service notation(s) to define applicable requirements as defined in [4.9] and listed in Tab 2.

Table 2 : List of service notations and additional service features for offshore service vessels

Service notation [ref. in Part A] Additional service feature	Associated service notation [ref. in Part A] Additional service feature	Reference Reference	
Offshore construction barge [4.9.2]	accommodation [4.9.5] SPxxx or SPxxx-capable MOU	Part E, Chapter 11	
	lifting [4.9.6]	Part E, Chapter 8	
	pipe laying [4.9.7]	Part E, Chapter 12	
Offshore construction vessel [4.9.3]	accommodation [4.9.5] SPxxx or SPxxx-capable MOU	Part E, Chapter 11	
	cable laying [4.9.8] (1)	Part E, Chapter 6	
	diving support-integrated [4.8.5] diving support-capable [4.8.5] diving support-portable [4.8.5] DD or SD	Part E, Chapter 7	
	lifting [4.9.6]	Part E, Chapter 8	
	pipe laying [4.9.7]	Part E, Chapter 12	
	Offshore support vessel [4.9.4]	accommodation [4.9.5] SPxxx or SPxxx-capable MOU	Part E, Chapter 11
anchor handling [4.8.2]		Part E, Chapter 2	
diving support-integrated [4.8.5] diving support-capable [4.8.5] diving support-portable [4.8.5] DD or SD		Part E, Chapter 7	
fire-fighting [4.8.3] (1) 1, 2, 3 or E water spraying		Part E, Chapter 4 Pt E, Ch 4, Sec 3 Pt E, Ch 4, Sec 4	
lifting [4.9.6]		Part E, Chapter 8	
oil recovery [4.8.4] OILTREAT SECOND-LINE		Part E, Chapter 5	
standby rescue [4.9.9] number of survivors ship operation area		Part E, Chapter 10	
supply [4.9.10] (1) HNLS or WELLSTIM (6)		Part E, Chapter 3	
tug [4.7] (1) (design bollard pull = $[T_{BP}/9,81]$ t) (standardized design bollard pull = $[T_{BP}/9,81]$ t)		Part E, Chapter 1 Pt E, Ch 1, Sec 1	
ADDITIONAL SERVICE FEATURES (2)			
no propulsion [4.10.3] (3)			Part D, Chapter 14
self elevating [4.9.2], [4.9.3] or [4.9.4]		Pt E, Ch 8, Sec 7	
wind turbine installation [4.9.2], [4.9.3] or [4.9.4] (4)			
SRTP [4.17.1] (5)		Part D, Chapter 11	
(1) For ships granted with the service notation cable laying , fire-fighting , supply or tug , the corresponding type of ship according to SOLAS (Reg 1/2(g)) may be cargo ship.			
(2) Other additional service features as listed in Tab 1 may be assigned to offshore service vessels.			
(3) Only for service notation offshore construction barge .			
(4) Only for service notation offshore construction barge and offshore construction vessel .			
(5) Only completing the additional service feature SPxxx , when conditions are met as defined in [4.17.1].			
(6) May be completed by the following notation(s): - FP ≤ 60°C, - toxic , - acids , - LG .			

4.2 Cargo ships

4.2.1 The service notations related to self-propelled ships intended for the carriage of cargo are listed in [4.2.2] to [4.2.7].

4.2.2 General cargo ship, for ships intended to carry general cargo.

The service notation may be completed by the following additional service feature, as applicable:

- **equipped for carriage of containers**, where the ship's fixed arrangements comply with the applicable rule requirements in Part D, Chapter 2
- **heavycargo** [AREA1, X1 kN/m² - AREA2, X2 kN/m² - ...], as defined in [4.17.4].
- **nonhomload**, when the ship has been designed in such a way that the cargo spaces may be loaded non-homogeneously, including cases where some holds may be empty, at a draught up to the scantling draught and fulfil the appropriate rule requirements for general strength, and when the corresponding loading conditions are listed in the reviewed loading manual. This notation may be completed with the indication of the different maximum loads allowed in each hold and which holds may be empty, if appropriate.
- **occasional dry bulk cargo**, for ships the keels of which are laid or which are at a similar stage of construction on or after the 1st July 2010, and which occasionally carry dry cargoes in bulk, as described in IMO Res.MSC 277(85), paragraphs 1.6 and 1.7.

The additional requirements of Ch 4, Sec 7 are applicable to these ships.

4.2.3 Ro-ro cargo ship, for ships specially intended to carry vehicles, trains or loads on wheeled beds. The additional requirements of Ch 4, Sec 6 and Part D, Chapter 1 are applicable to these ships. The service notation may be completed by the additional service feature **equipped for carriage of containers**, where the ship's fixed arrangements comply with the applicable requirements of Part D, Chapter 2.

4.2.4 PCT carrier (Pure Car and Truck carrier), for ships with high number of decks, specially intended to carry road vehicles as cargo. The additional requirements of Ch 4, Sec 6 and Part D, Chapter 1 are applicable to these ships.

4.2.5 Refrigerated cargo ship, for ships specially intended to carry refrigerated cargo. No additional requirements are specified in Part D for this service notation; however, the requirements of Part F, Chapter 7 for the assignment of the additional class notation **REF-CARGO** are to be applied. The service notation may be completed by the additional service feature **equipped for carriage of containers**, where the ship's fixed arrangements comply with the applicable rule requirements in Part D, Chapter 2.

4.2.6 Container ship, for ships specially intended to carry containers in holds or on decks. The additional requirements of Ch 4, Sec 8, [2] and Part D, Chapter 2 are applicable to these ships.

For container ships complying with the requirements of NR583 Whipping and Springing Assessment, the service notation is to be completed by the additional service features **WhiSp1** or **WhiSp2**.

4.2.7 Livestock carrier, for ships specially intended to carry livestock. The additional requirements of Ch 4, Sec 8, [3] and Part D, Chapter 3 are applicable to these ships.

4.2.8 Deck ship, for ships specially intended to carry cargo exclusively on the deck.

Note 1: A ship with service notation **deck ship** is usually but not necessarily a self-propelled unit intended for unrestricted navigation.

4.3 Bulk, ore and combination carriers

4.3.1 The service notations related to self-propelled ships specially intended for the carriage of dry cargo in bulk are those listed in [4.3.2] to [4.3.6] or in Part D, Chapter 4 for **bulk carrier** when the ship does not meet the forthcoming conditions.

The service notations described in [4.3.2] to [4.3.6] are always completed by the additional service feature **ESP**, which means that these ships are submitted to the Enhanced Survey Program as laid down in Ch 4, Sec 2.

Example: **ore carrier ESP**.

Note 1: Self-propelled ships are ships with mechanical means of propulsion not requiring assistance from another ship during normal operation.

4.3.2 Bulk carrier ESP, for sea going self-propelled ships which are constructed generally with single deck, double bottom, hopper side tanks and topside tanks and with single or double side skin construction in cargo length area and intended primarily to carry dry cargoes in bulk. Typical midship sections are illustrated in Fig 1, or a midship section deemed equivalent by the Society. The additional requirements of Part D, Chapter 4 are applicable to these ships.

The service notation **bulk carrier ESP** is always completed by one of the following additional service features, for bulk carriers of length greater than or equal to 150 m contracted for new construction on or after 1 July 2003:

- **BC-A**, for bulk carriers designed to carry dry bulk cargoes of density 1.0 t/m³ and above with specified holds empty at maximum draught in addition to BC-B conditions
- **BC-B**, for bulk carriers designed to carry dry bulk cargoes of density 1.0 t/m³ and above with all cargo holds loaded in addition to BC-C conditions
- **BC-C**, for bulk carriers designed to carry dry bulk cargoes of density less than 1.0 t/m³.

The additional service feature **BC-A** is completed with the indication of the allowed combination of specified empty holds, as follows: (**holds a, b, ..., ... may be empty**).

If limitations are to be observed during operation:

- the additional service features **BC-A** and **BC-B** are completed, when the maximum cargo density is less than 3.0 t/m³, with the indication of the maximum density of cargo that the ship is allowed to carry, as follows: (**maximum cargo density x.y t/m³**)

- the additional service features **BC-A**, **BC-B** and **BC-C** are completed by the following indication when the vessel has not been designed for loading and unloading in multiple ports: **(no MP)**.
- the additional service feature **BC-A** is completed by the notation **(Block-loading)** when the ship is intended to operate in alternate block load condition, according to Common Structural Rules for Bulk Carriers and Double Hull Oil Tankers (Rule Note NR606), Pt 1, Ch 1, Sec 1, [3.2.1]. The requirements for **(Block-loading)** notation are defined in NR606, Pt 1, Ch 4, Sec 8, [4.2.3].

Examples:

Bulk carrier BC-A (maximum cargo density 2.5 t/m³; holds 2, 4, 6 may be empty) ESP

Bulk carrier BC-B (maximum cargo density 2.5 t/m³; no MP) ESP

Bulk carrier BC-C (no MP) ESP

For ships contracted for new construction before 1 July 2003 or for ships contracted for new construction on or after 1 July 2003 but less than 150 m in length, the service notation **bulk carrier ESP** may be completed by the additional service features **heavycargo** or **nonhomload** defined under [4.2.2].

The service notation **bulk carrier ESP** is always completed by the additional service feature **CSR** for bulk carriers of length greater than or equal to 90 m contracted for new construction on or after 1 April 2006.

Bulk carriers assigned with the additional service feature **CSR** are to comply with the requirements of:

- the Common Structural Rules for Bulk Carriers (Rule Note NR522), when contracted for construction on or after 1 April 2006 and before 1 July 2015. The elements not dealt with in NR522 are to comply with the requirements of Part B, Part C and Part D of the Rules for the Classification of Steel Ships.

Note 1: Hybrid bulk carriers, where at least one cargo hold is constructed with hopper tank and topside tank, are covered by NR522. The structural strength of members in holds constructed without hopper tank and/or topside tank is to comply with the strength criteria defined in NR522.

- the Common Structural Rules for Bulk Carriers and Oil Tankers (Rule Note NR606) when contracted for construction on or after 1 July 2015. The elements not dealt with in NR522 are to comply with the requirements of Part B, Part C and Part D of the Rules for the Classification of Steel Ships.

Bulk carriers assigned with the additional service feature **CSR** and with holds designed for loading/unloading by grabs having a maximum specific weight up to [X] tons are assigned the notation **GRAB [X]** according to NR522 (Common Structural Rules for Bulk Carriers), Ch 1, Sec 1, [3.2.1] or NR606 (Common Structural Rules for Bulk Carriers and Oil Tankers), Pt 1, Ch 1, Sec 1, [3.2.2], as applicable. The requirements for **GRAB [X]** notation are given in NR522, Ch 12, Sec 1 or NR606, Pt 2, Ch 1, Sec 6, as applicable.

For bulk carriers assigned with the additional service feature **CSR**, and one of the additional service features **BC-A** or **BC-B**, these additional service features are always completed by the additional service feature **GRAB [X]**. For these ships, the requirements for the **GRAB [X]** notation are to be complied with for an unladen grab weight X equal to or greater than 20 tons.

For bulk carriers assigned with the additional service feature **CSR** others than above, the additional class notation **GRAB [X]** may be assigned on a voluntary basis (refer to [6.13.2], item a)).

Bulk carriers assigned with the additional service feature **CSR** are to comply with the requirements for maintenance of class, thickness measurements and acceptance criteria given in NR522, Chapter 13 or NR606, Part 1, Chapter 13 as applicable.

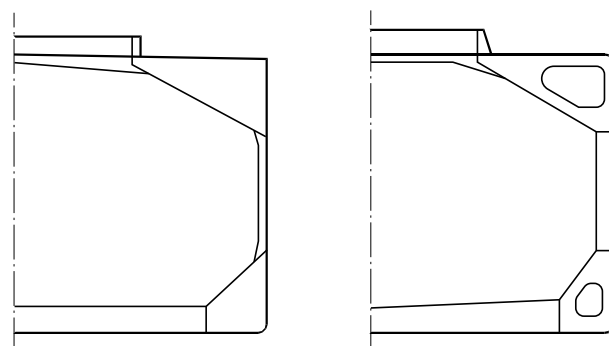
For bulk carriers assigned with the additional service feature **CSR** and contracted for construction on or after 8 December 2006, this additional service feature is always completed by the additional service feature **CPS(WBT)** for which the rule requirements of NR530 Coating Performance Standard, applicable to ships complying with the requirements of the Common Structural Rules for Bulk Carriers or the Common Structural Rules for Double Hull Oil Tankers and related to protective coatings in dedicated seawater ballast tanks of ships of not less than 500 gross tonnage and double-side skin spaces arranged in bulk carriers of length greater than or equal to 150 m, are applied.

Example:

Bulk carrier CSR CPS(WBT) BC-A (maximum cargo density 2.5 t/m³; holds 2, 4, 6 may be empty) ESP GRAB [20]

Note 2: Attention is drawn on the coating condition which is surveyed as per the requirements of Ch 4, Sec 2 for ships in service.

Figure 1 : Typical midship sections of ships with service notation bulk carrier ESP

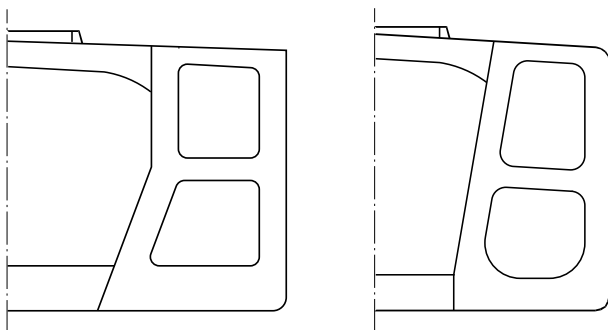


Left: Single side skin construction

Right: Double side skin construction.

4.3.3 Ore carrier ESP, for sea going self-propelled ships which are constructed generally with single deck, two longitudinal bulkheads and a double bottom throughout the cargo length area and intended primarily to carry ore cargoes in the centre holds only. Typical midship sections are illustrated in Fig 2, or a midship section deemed equivalent by the Society. The additional requirements of Part D, Chapter 5 are applicable to these ships.

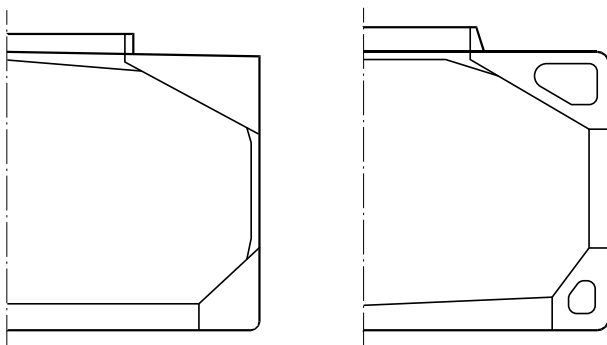
Figure 2 : Typical midship sections of ship with service notation ore carrier ESP



4.3.4 Combination carrier/OBO ESP, for sea going self-propelled ships which are constructed generally with single deck, double bottom, hopper side tanks and topside tanks and with single or double side skin construction in the cargo length area, and intended primarily to carry oil or dry cargoes, including ore, in bulk. Typical midship sections are illustrated in Fig 3, or a midship section deemed equivalent by the Society. The additional requirements of Part D, Chapter 6 are applicable to these ships.

Note 1: Ships assigned with the service notation **combination carrier/ OBO ESP** that do not comply with MARPOL I/19 may be subject to International and/or National Regulations requiring phase out.

Figure 3 : Typical midship sections of ship with service notation combination carrier/OBO ESP



Left: Single side skin construction

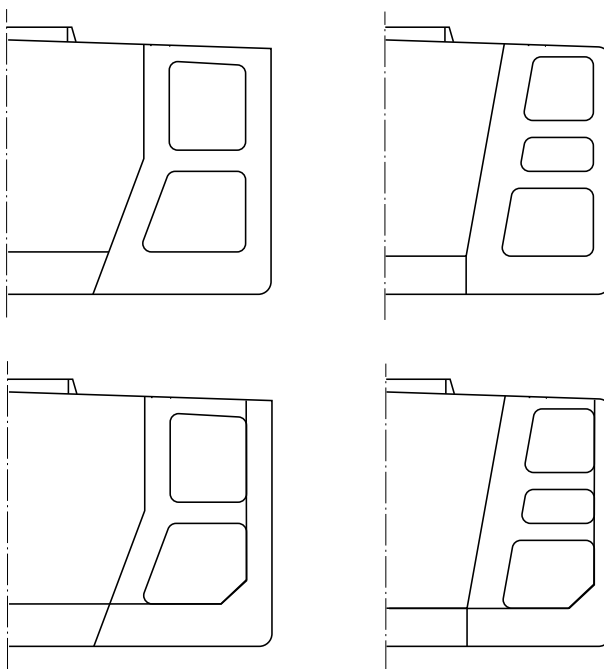
Right: Double side skin construction.

4.3.5 Combination carrier/OOC ESP, for sea going self-propelled ships which are constructed generally with single deck, two longitudinal bulkheads and a double bottom throughout the cargo length area and intended primarily to carry ore cargoes in the centre holds or oil cargoes in centre holds and wing tanks. Typical midship sections are illustrated in Fig 4, or a midship section deemed equivalent by the Society. The additional requirements of Part D, Chapter 6 are applicable to these ships.

Note 1: "combination carrier" is a general term applied to ships intended for the carriage of both oil and dry cargoes in bulk; these cargoes are not carried simultaneously, with the exception of oily mixture retained in slop tanks.

Note 2: Ships assigned with the service notation **combination carrier/OOC ESP** that do not comply with MARPOL I/19 may be subject to International and/or National Regulations requiring phase out.

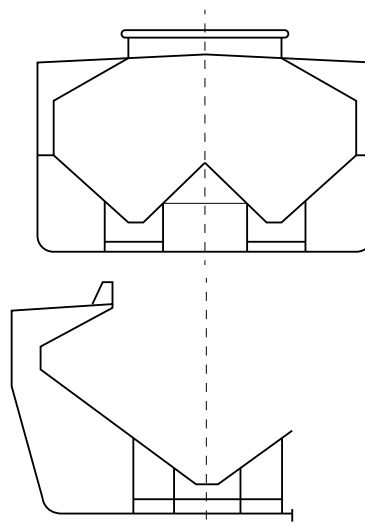
Figure 4 : Typical midship sections of ships with service notation combination carrier/OOC ESP



4.3.6 Self-unloading bulk carrier ESP, for sea going self-propelled ships which are constructed generally with single deck, double bottom, hopper side tanks and topside tanks with single or double side skin construction in cargo area and intended primarily to carry and self-unload dry cargoes in bulk. Typical midship sections are given in Fig 5, or a midship section deemed equivalent by the Society. The additional requirements of Part D, Chapter 4 are applicable to these ships.

The service notation **self-unloading bulk carrier ESP** may be completed by the additional service feature **heavycargo** or **nonhomload** defined in [4.2.2].

Figure 5 : Typical midship sections of ship with service notation self-unloading bulk carrier ESP



4.4 Ships carrying liquid cargo in bulk

4.4.1 The service notations related to self-propelled ships intended for the carriage of liquid cargo in bulk are listed in [4.4.2] to [4.4.10].

4.4.2 Oil tanker, for sea going self-propelled ships which are constructed generally with integral tanks and intended primarily to carry in bulk crude oil, other oil products, or oil-like substances having any flash point, or liquid at atmospheric pressure and ambient temperature (or thus maintained by heating). This notation may be assigned to tankers of both single and double hull construction, as well as tankers with alternative structural arrangements, e.g. mid-deck designs.

The service notation may be completed by the additional service feature **flash point > 60°C**, as applicable, where the ship is intended to carry only such type of products, under certain conditions.

The service notation may be completed by the additional service feature **asphalt carrier**, where the ship is intended to carry such type of products, under certain conditions. The maximum cargo temperature is to be indicated on the Certificate of Classification.

The additional requirements of Part D, Chapter 7 are applicable to these ships.

For ships with integral cargo tanks, the service notation **oil tanker** is always completed by the additional service feature **ESP** (i.e. **oil tanker ESP**), which means that these ships are submitted to the Enhanced Survey Program as laid down in Ch 4, Sec 3. Typical midship sections are illustrated in Fig 6.

The service notation **oil tanker ESP** is always completed by the additional service feature **CSR** for double hull oil tankers of length greater than or equal to 150 m and contracted for new construction on or after 1 April 2006.

Oil tankers assigned with the additional service feature **CSR** are to comply with the requirements of:

- the Common Structural Rules for Double Hull Oil Tankers (Rule Note NR523), when contracted for construction on or after 1 April 2016 and before 1 July 2015. The elements not dealt with in NR523 are to comply with

the requirements of Part B, Part C and Part D of the Rules for the Classification of Steel Ships.

- the Common Structural Rules for Bulk Carriers and Oil Tankers (Rule Note NR606), when contracted for construction on or after 1 July 2015. The elements not dealt with in NR523 are to comply with the requirements of Part B, Part C and Part D of the Rules for the Classification of Steel Ships.

Oil tankers assigned with the additional service feature **CSR** are to comply with the requirements for ship in operation renewal criteria given in NR523, Section 12, or NR606, Part 1, Chapter 13, as applicable, related to the allowable thickness diminution for hull structure.

For oil tankers assigned with the additional service feature **CSR** and contracted for construction on or after 8 December 2006, this additional service feature is always completed by the additional service feature **CPS(WBT)** for which the rule requirements of NR530 Coating Performance Standard, applicable to ships complying with the requirements of the Common Structural Rules for Bulk Carriers or the Common Structural Rules for Double Hull Oil Tankers and related to protective coatings in dedicated seawater ballast tanks of ships of not less than 500 gross tonnage and double-side skin spaces arranged in bulk carriers of length greater than or equal to 150 m, are applied.

Example:

Oil tanker CSR CPS(WBT) ESP

Note 1: Attention is drawn on the coating condition which is surveyed as per the requirements of Ch 4, Sec 3 for ships in service.

Note 2: Ships assigned with the service notation **oil tanker ESP** that do not comply with MARPOL I/19 may be subject to International and/or National Regulations requiring phase out under MARPOL I/20 and/or MARPOL I/21.

4.4.3 Asphalt carrier, for sea going self-propelled ships which are constructed with independent (non-integral) cargo tanks, intended to carry only such type of products, under certain conditions. The additional requirements of Part D, Chapter 7 are applicable to these ships.

The maximum cargo temperature is to be indicated on the Certificate of Classification.

Figure 6 : Typical midship sections of ships with service notation oil tanker ESP

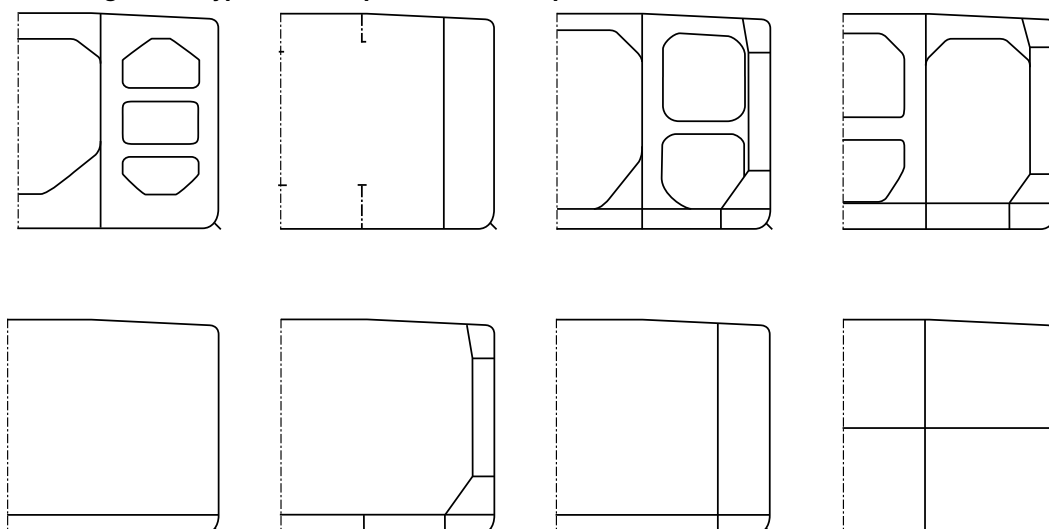
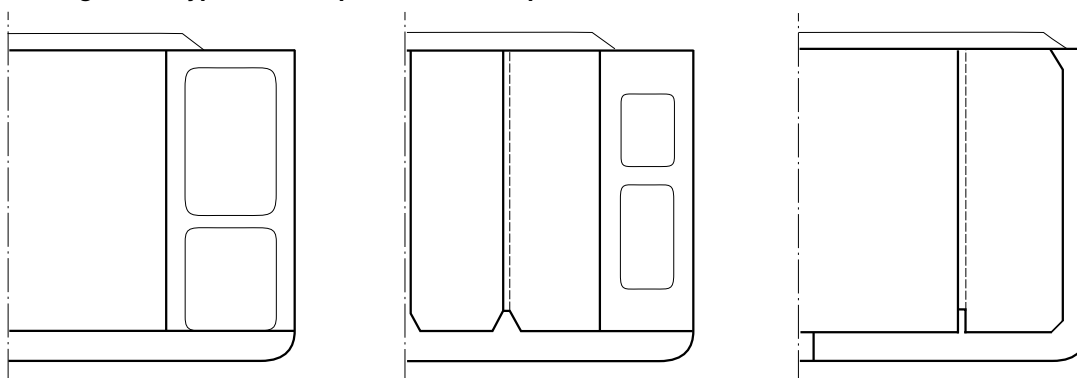


Figure 7 : Typical midship sections of ships with service notation chemical tanker ESP



4.4.4 Chemical tanker, for sea going self-propelled ships which are constructed generally with integral tanks and intended primarily to carry chemicals in bulk. This notation may be assigned to tankers of both single or double hull construction, as well as tankers with alternative structural arrangements. Typical midship sections are illustrated in Fig 7, or a midship section deemed equivalent by the Society. The additional requirements of Part D, Chapter 8 are applicable to these ships.

The list of products the ship is allowed to carry is attached to the Certificate of Classification or the Certificate of Fitness, where issued by the Society, including, where necessary, the maximum allowable specific gravity and/or temperature.

For ships intended to carry only one type of cargo, the service notation may be completed by the additional service feature indicating the type of product carried.

Example:

chemical tanker - Molten Sulphur

For ships with integral cargo tanks, the service notation **chemical tanker** is always completed by the additional service feature **ESP** (i.e. **chemical tanker ESP**), which means that these ships are submitted to the Enhanced Survey Programme as laid down in Ch 4, Sec 4.

The service notation **chemical tanker** is to be completed by the corresponding ship type **IMO Type 1**, **IMO Type 2** or **IMO Type 3**, as relevant and as defined in the IMO IBC Code as amended.

4.4.5 Liquefied gas carrier, for ships specially intended to carry liquefied gases or other substances listed in Pt D, Ch 9, Sec 1 of the Rules. The additional requirements of Ch 4, Sec 5 and Part D, Chapter 9 are applicable to these ships.

The list of products the ship is allowed to carry is attached to the Certificate of Classification or the Certificate of Fitness, where issued by the Society, including, where necessary, the conditions of transportation (pressure, temperature, filling limits).

The service notation is to be completed by the following additional service feature indicating the cargo type, the IMO code ship type, the cargo tank design pressure P_{design} and minimum temperature T_{min} : (**[cargo type]**, **[ship type]**, **[P_{design}]**, **[T_{min}]**) with:

- **[cargo type]** to be taken as one of the following: **LNG**, **LEG** or **LPG**

- **[ship type]** to be taken as one of the following: **IMO Type 1G**, **IMO Type 2G**, **IMO Type 2PG** or **IMO Type 3G**

- **[P_{design}]** the value of the maximum vapour pressure, in barg

- **[T_{min}]** the value of the minimum cargo temperature, in °C.

The service notation is completed by the following additional service features, as applicable:

- **BOG-reliquefaction**, where the ship is fitted with a reliquefaction installation. The requirements for the assignment of this additional service feature are given in Pt D, Ch 9, Sec 1, [7]
- **LNG-subcooling**, where the ship is fitted with a cooling installation aiming at reducing the cargo temperature. The requirements for the assignment of this additional service feature are given in Pt D, Ch 9, Sec 1, [7]
- **REGAS**, where the ship is fitted with an installation for revaporisation of the liquefied natural gas. The requirements for the assignment of this additional service feature are given in NR645, Sec 10
- **STL-SPM**, where the ship is used as re-gasification terminal and fitted forward with equipment for non permanent mooring or single buoy. The requirements for the assignment of this additional service feature are given in Pt D, Ch 9, Sec 1, [8].

Example:

**liquefied gas carrier (LNG, IMO Type 2G, 0,35 barg, -163°C)
REGAS STL-SPM**

4.4.6 LNG bunkering ship, for ships carrying liquefied natural gas (LNG) and intended to ensure the transfer of LNG to ships using LNG as fuel.

The additional requirements of Ch 4, Sec 5 and Rule Note NR620 LNG Bunkering Ship are applicable to these ships.

The service notation is to be completed by the additional service feature (**[cargo type]**, **[ship type - IGC Code]**, **[cargo tank design pressure]**, **[minimum temperature]**) as defined in [4.4.5].

The service notation may be completed by the following additional service features, as applicable:

- **RE**, where the ship is designed to receive LNG from a gas fuelled ship for which the LNG fuel tanks have to be emptied

- **Initial-CD**, where the ship is designed for initial cooling down of the gas fuelled ship LNG fuel tank
- **IG-Supply**, where the ship is designed to supply inert gas and dry air, to ensure gas freeing and aeration, to a gas fuelled ship complying with IGF Code, paragraph 6.10.4
- **BOG**, where the ship is designed to recover and manage the boil-off gas generated during the bunkering operation.

4.4.7 FLS tanker, for ships specially intended to carry in bulk flammable liquid products other than those covered by the service notations **oil tanker**, **chemical tanker** or **liquefied gas carrier**.

The list of products the ship is allowed to carry may be attached to the Certificate of Classification, including, where necessary, the maximum allowable specific gravity and/or temperature.

The service notation may be completed by the additional service feature **flash point > 60°C**, where the ship is intended to carry only such type of products, under certain conditions.

For ships intended to carry only one type of cargo, the service notation may be completed by the additional service feature indicating the type of product carried.

The additional requirements of Ch 4, Sec 8, [4] and Part D, Chapter 7 are applicable to these ships.

4.4.8 Tanker, for ships intended to carry non-flammable liquid cargoes in bulk other than those covered by the service notations in [4.4.2] to [4.4.7], such as water.

The list of cargoes the ship is allowed to carry may be attached to the Certificate of Classification.

For ships intended to carry only one type of cargo, the service notation may be completed by the additional service feature indicating the type of product carried, e.g. **tanker-water**.

The additional requirements of Part D, Chapter 10 are applicable to these ships.

4.4.9 Refer also to [4.3.4] and [4.3.5] for **combination carrier** intended to carry alternatively oil products and dry cargo in bulk in cargo holds/tanks.

4.4.10 Oil storage service, assigned on a case by case basis and subject to flag agreement, to ships formerly granted with the service notation **oil tanker ESP** and intended to be used as oil storage unit with the following restrictions:

- the ship is stationed at a single location, without transit or carriage of cargo between ports or different sites
- the use of the ship will be limited to storage in a dedicated single location. This location is to be situated in a sheltered area or an area enabling the ship to quickly move away from severe weather conditions
- the provisions provided when the ship is in its storage service period are no longer applicable if the ship leaves the dedicated storage service location, except when moving away from severer weather conditions
- when seeking shelter from severe weather conditions into a port of refuge, the ship is not allowed to discharge to a terminal, except on a case by case basis where repairs in a shipyard are required

- the ship may move without cargo on board to repair facilities or lay-up site, on a case-by-case basis
- the **ESP** notation has been withdrawn as far as the vessel is stationed as an oil storage unit and will be reinstated as soon as the vessel leaves the storage site to resume trading.

Periodical bottom surveys can be performed afloat and to this end the additional class notation **INWATERSURVEY** defined in [6.14.3] is to be granted.

The machinery part is to remain classed and the additional class notation **MON-SHAFT** defined in [6.6.3] is to be granted.

When granting the service notation **oil storage service**, a memoranda is to be endorsed in order to record the following:

- date of change in service notation,
- date of withdrawal of ESP notation together with Flag agreement references,
- location where the unit is stationed together with navigation notation.

When a ship starts its period as a storage service, the normal survey requirements are still applicable as follows:

- hull class renewal survey is carried out according to ESP requirements as laid down in Ch 4, Sec 3, [6], with a possibility to have the concurrent bottom inspection done afloat, provided that conditions laid down in Ch 3, Sec 4, [3] are met,
- other periodical surveys are carried out according to Part A, Chapter 3 as applicable.

When completing the storage service period, and before resuming trading, all surveys from which the ship has been relaxed during its storage period, have to be carried out, including possible surveys in drydock condition; upon completion of satisfactory surveys, the service notation **oil tanker ESP** will be reinstated to the ship and related surveys will become fully applicable.

Note 1: the mooring arrangements of the vessel, including their compliance with any authority's requirement, are left to the responsibility of the owner when granted the service notation **oil storage service**.

4.5 Ships carrying passengers

4.5.1 The service notations related to ships specially intended for the carriage of passengers are listed in [4.5.2] to [4.5.3].

4.5.2 Passenger ship, for ships intended to carry more than 12 passengers. The additional requirements of Ch 4, Sec 6 and Part D, Chapter 11 are applicable to these ships.

The service notation may be completed by the additional service feature ≤ 36 **passengers**, where the ship is intended to carry only such a limited number of passengers.

The service notation is to be completed by the additional service feature **SRTP** for ships complying with the provisions of Part D, Chapter 11.

4.5.3 Ro-ro passenger ship, for ships intended to carry more than 12 passengers and specially equipped to load trains or wheeled vehicles. The additional requirements of Ch 4, Sec 6 and Part D, Chapter 12 are applicable to these ships.

The service notation may be completed by the additional service feature ≤ 36 **passengers**, where the ship is intended to carry only such a limited number of passengers.

The service notation is to be completed by the additional service feature **SRTP** for ships complying with the provisions of Part D, Chapter 12.

4.6 Ships for dredging activities

4.6.1 The service notations related to ships specially intended for dredging activities are listed in [4.6.2]. The additional requirements of Ch 4, Sec 8, [5] and Part D, Chapter 13 are applicable to these ships.

4.6.2 The following notations are provided:

- a) **dredger**, for ships specially equipped only for dredging activities (excluding carrying dredged material)
- b) **hopper dredger**, for ships specially equipped for dredging activities and carrying spoils or dredged material
- c) **hopper unit**, for ships specially equipped for carrying spoils or dredged material
- d) **split hopper unit**, for ships specially equipped for carrying spoils or dredged material and which open longitudinally, around hinges
- e) **split hopper dredger**, for ships specially equipped for dredging and for carrying spoils or dredged material and which open longitudinally, around hinges.

4.6.3 These ships which are likely to operate at sea within specific limits may, under certain conditions, be granted an operating area notation. For the definition of operating area notation, reference should be made to [5.3].

4.7 Tugs

4.7.1 General

Ships intended to tow and/or push other ships or units are assigned one of the service notation defined in [4.7.2], [4.7.3] or [4.7.4].

The additional requirements of Ch 4, Sec 8, [6] and Part E, Chapter 1 are applicable to these ships.

These service notations may be completed by the additional service feature **barge combined**, when the units are designed to be connected with barges and comply with the relevant requirements of Pt E, Ch 1, Sec 4. The barges to which the tug can be connected are specified in a memoranda.

These service notations are always completed by the additional service feature (**standardized design bollard pull = $[T_{BP}/9,81]$ t**).

Note 1: Ships contracted for construction before 1 July 2020 and not meeting the bollard pull test requirements for the assignment of the additional service feature (**standardized design bollard pull = $[T_{BP}/9,81]$ t**) are assigned the additional service feature (**design bollard pull = $[T_{BP}/9,81]$ t**), subject to bollard pull tests being carried out according to a procedure accepted by the Society.

The requirements for the assignment and the maintenance of this additional service feature are given respectively in Part E, Chapter 1 and Ch 4, Sec 8, [6].

Ships granted with the additional service feature (**design bollard pull = $[T_{BP}/9,81]$ t**) may be granted with the additional service feature (**standardized design bollard pull = $[T_{BP}/9,81]$ t**) after having satisfactorily carried out the bollard pull test laid down in Pt E, Ch 1, App 1.

These ships which are likely to operate at sea within specific limits may, under certain conditions, be granted an operating area notation. For the definition of operating area notation, reference should be made to [5.3].

4.7.2 Tug

The service notation **tug** is assigned to ships specially equipped for towing and/or pushing.

Note 1: The service notation **tug** may also be used as additional service notation combined with **offshore support vessel**.

4.7.3 Salvage tug

The service notation **salvage tug** is assigned to ships specially equipped for towing and/or pushing, having specific equipment for salvage.

4.7.4 Escort tug

The service notation **escort tug** is assigned to ships specially equipped for towing and/or pushing having specific equipment for escorting ships or units during navigation.

The service notation **escort tug** is always completed by the following additional service features:

- (**design maximum braking force = $[T_{X,MAX}/9,81]$ t**)
where the value $T_{X,MAX}$ is the highest rated braking force over the applicable range of loading conditions and escort speeds
- (**design maximum escort speed = $[V_{MAX}]$ kn**)
where the value V_{MAX} is the highest escort speed for which the escort tug is considered to perform escort operations
- (**design maximum steering force = $[T_{Y,MAX}/9,81]$ t**)
where the value $T_{Y,MAX}$ is the highest rated steering force over the applicable range of loading conditions and escort speeds.

4.8 Working ships

4.8.1 General

The service notations related to ships specially intended for different working services are listed in [4.8.2] to [4.8.5]. These service notations may be assigned directly to a ship or combined within the service notations **offshore support vessel** or **offshore construction vessel** defined in [4.9].

4.8.2 Anchor handling vessel

The service notation anchor handling is assigned to towing vessels and/or supply vessels equipped with winches for anchor handling, having an open stern to allow the decking of anchors and an appropriate thrust to perform the intended anchor handling operations, consisting in deployment, recovering and repositioning of anchors and the associated mooring lines of rigs or other vessels. The additional requirements of Ch 4, Sec 8, [10] and Part E, Chapter 2 are applicable to these ships.

Note 1: As a rule, the service notation tug is also to be assigned in combination with the service notation anchor handling vessel; the additional requirements of Ch 4, Sec 8, [6] and Part E, Chapter 1 are applicable to these ships

4.8.3 Fire-fighting ship

The service notation **fire-fighting** is assigned to ships specially intended and equipped for fighting fire. The additional requirements of Ch 4, Sec 8, [8] and Part E, Chapter 4 are applicable to these ships.

The service notation may be completed by the following additional service features, as applicable:

- **1** or **2** or **3**, when the ship complies with the applicable requirements of Pt E, Ch 4, Sec 3
- **E**, when the characteristics of the water fire-fighting system are not those required for the assignment of the additional service features **1**, **2** or **3**, and when the system is specially considered by the Society
- **water spraying**, when the ship is fitted with a water-spraying system complying with the applicable requirements of Pt E, Ch 4, Sec 4, [3].

4.8.4 Oil recovery ship

The service notation **oil recovery** is assigned to ships specially equipped with fixed installations and/or mobile equipment for the removal of oil from the sea surface and its retention on board, carriage and subsequent unloading. The additional requirements of Ch 4, Sec 8, [9] and Part E, Chapter 5 are applicable to these ships.

The service notation may be completed by the following additional service features, as applicable:

- **OILTREAT** may be assigned to ships designed and equipped to recover polluted water which is subjected to a chemical and/or a physical treatment, in order to separate the oil from the polluted water. The separated oil is to be stored and transported in dedicated tanks
- **SECOND-LINE** may be assigned to ships designed and equipped to recover polluted water in the event of spills of oils which have, at the time of recovery, a flash point exceeding 60°C (closed cup test). This service feature is not to be assigned to oil recovery ships carrying heated recovered oils within 15°C of their flash point.

4.8.5 Diving support

The following service notations are assigned to units specially intended for support of diving operation:

- Diving support-integrated**, for ships and units having a permanent diving system installed
- Diving support-capable**, for ships and units having a non-permanent diving system and when the diving equipment is not installed
- Diving support-portable**, for ships and units having a non-permanent diving system and when the diving equipment is installed.

The requirements for the assignment of these service notations are given in Part E, Chapter 7.

The service notations **diving support-integrated** and **diving support-portable** are to be completed by the following additional service features:

- DD**, when the ship is equipped with a deep diving system
- SD**, when the ship is equipped with a shallow diving system.

The additional requirements of Ch 4, Sec 8, [13] are applicable to ships or units assigned with the service notations **diving support-integrated** or **diving support-portable**.

Note 1: The classification of the diving support units and the classification of the diving systems are independent. The diving systems are covered by NR610, Rules for the Classification of Diving Systems.

Note 2: For non-permanent diving systems, the notation **diving support-capable** is to be replaced by the temporary notation **diving support-portable** before conducting any diving operations. To this end, requirements of Part E, Chapter 7 are to be fulfilled allowing the service to become fully effective.

4.9 Offshore service vessels

4.9.1 General

The following service notations are assigned to ships or units specially intended for offshore operations:

- **offshore construction barge** (), as defined in [4.9.2]
- **offshore construction vessel** (), as defined in [4.9.3]
- **offshore support vessel** (), as defined in [4.9.4]

with between brackets the relevant combined service notations defined in [4.7.2], [4.8] and [4.9.5] to [4.9.10].

The service notations **offshore construction barge**, **offshore construction vessel** and **offshore support vessel** are always associated with one or several other service notation(s) listed in [4.9.5] to [4.9.10] and as indicated in [4.9.2], [4.9.4] and [4.9.3].

The service notations listed in [4.9.5] to [4.9.10] are not considered as stand-alone service notations and can not be granted without being associated with one of the following service notation: **offshore construction barge**, **offshore construction vessel** and **offshore support vessel**.

Ships assigned with service notation **offshore construction barge**, **offshore construction vessel** or **offshore support vessel** and fitted with legs complying with Pt E, Ch 8, Sec 7, are eligible for the assignment of the notation **self elevating**.

The service notations **offshore construction barge** or **offshore construction vessel** may be completed by - **wind turbine installation** for ships intended to operate in wind farms.

4.9.2 Offshore construction barge

The service notation **offshore construction barge** is assigned to non-propelled units intended to perform construction operation offshore.

The service notation is to be completed with, between brackets and separated by a semicolon, one or several of the following service notations and their relevant additional service feature:

- **accommodation** (as defined in [4.9.5])
- **lifting** (as defined in [4.9.6])
- **pipe laying** (as defined in [4.9.7]).

The service notation **offshore construction barge** is to be complete by the additional service feature **-no propulsion** defined in [4.10.3].

Offshore construction barges fitted with legs are granted with the additional service feature **self elevating**, when found in compliance with the relevant requirements of Pt E, Ch 8, Sec 7. The requirements for the maintenance of the notation are given in NR445 Rules for the Classification of Offshore Units, Part A, Chapter 2, as applicable.

Offshore construction barges dedicated to wind turbine installation operations may be assigned with the additional service feature - **wind turbine installation**.

Example: **offshore construction barge (accommodation SP150; lifting) -no propulsion**.

4.9.3 Offshore construction vessel

The service notation **offshore construction vessel** is assigned to ship-shaped, self-propelled units intended to perform construction operations at sea.

The service notation is to be completed with, between brackets and separated by a semicolon, one or several of the following service notations and their relevant additional service feature:

- **accommodation** (as defined in [4.9.5])
- **cable laying** (as defined in [4.9.8])
- **diving support** (as defined in [4.8.5])
- **lifting** (as defined in [4.9.6])
- **pipe laying** (as defined in [4.9.7]).

Offshore construction vessels fitted with legs are granted with the additional service feature **self elevating**, when found in compliance with the relevant requirements of Pt E, Ch 8, Sec 7. The requirements for the maintenance of the notation are given in NR445 Rules for the Classification of Offshore Units, Part A, Chapter 2, as applicable.

Offshore construction vessels dedicated to wind turbine installation operations may be assigned with the additional service feature - **wind turbine installation**.

Example: **offshore construction vessel (lifting ; diving support integrated - DD) - wind turbine installation**.

4.9.4 Offshore support vessel

The service notation **offshore support vessel** is assigned to ship-shaped, self-propelled units intended to perform inspection, maintenance, repair or supply operations for an offshore installation.

The service notation is to be completed with, between brackets and separated by a semicolon, one or several of the following service notations and their relevant additional service feature:

- **accommodation** (as defined in [4.9.5])
- **anchor handling** (as defined in [4.8.2])
- **diving support** (as defined in [4.8.5])
- **fire-fighting** (as defined in [4.8.3])
- **lifting** (as defined in [4.9.6])
- **oil-recovery** (as defined in [4.8.4])
- **standby and rescue** (as defined in [4.9.9])
- **supply** (as defined in [4.9.10])
- **tug** (as defined in [4.7.2]).

Offshore support vessels fitted with legs are granted with the additional service feature **self elevating**, when found in compliance with the relevant requirements of Pt E, Ch 8, Sec 7. The requirements for the maintenance of the notation are given in NR445 Rules for the Classification of Offshore Units, Part A, Chapter 2, as applicable.

Example: **offshore support vessel (supply HNLS; fire-fighting 2; oil recovery OILTREAT) self elevating**.

4.9.5 Accommodation unit

In compliance with [4.9.2], [4.9.3] and [4.9.4] the service notation **accommodation** is assigned to ships intended to accommodate personnel working offshore.

This service notation is always completed by at least one of the following additional service feature when the ship complies with IMO Code of Safety for Special Purpose Ships carrying more than twelve (12) special personnel:

- **SPxxx**, when accommodation facilities are permanently installed on board and where **xxx** is the total number of persons on board, as defined in [4.17.1]
- **SPxxx-capable**, when accommodation facilities may be added as separate modules during the service life of the ship and where **xxx** is the total number of persons on board once the modules have been added, as defined in [4.17.1].

For ships granted with **SPxxx** and **SPxxx-capable** together, when modules are added or removed, the service features have to be adjusted accordingly. For example, for a ship granted with **SP100** and **SP200-capable**, when adding modules for 50 persons, the service features have then to be modified for **SP150** and **SP200-capable** or, when adding modules for 100 persons, **SP200** only.

For ships granted with **SPxxx-capable** only, when adding modules, the service features have to be adjusted accordingly. For example, for ship granted with **SP100-capable**, when adding modules for 50 persons, the service features have then to be modified for **SP50** and **SP100-capable** or, when adding modules for 100 persons, **SP100** only.

This service notation may be completed by the additional service feature **MOU** when the ship is complying with the requirements of the MODU Code, as defined in Pt E, Ch 11, Sec 1.

The requirements for the assignment of this notation are given Part E, Chapter 11.

4.9.6 Lifting unit

In compliance with [4.9.2], [4.9.3] and [4.9.4], the service notation **lifting** is assigned to ships or unit intended to perform lifting operations at sea, engaged in an operation involving the raising or lowering of objects using vertical force by means of winches, cranes, A-frames or other lifting devices.

The requirements for the assignment and maintenance of this notation are given respectively in Part E, Chapter 8 and in Ch 4, Sec 8, [12].

Note 1: The service notation **lifting** can only be granted to the ship if the corresponding lifting unit is covered by at least one of the additional class notations **ALM** or **OHS**.

4.9.7 Pipe laying unit

In compliance with [4.9.3] the service notation **pipe laying** is assigned to ships fitted with equipment used for assembling and installing rigid or flexible pipelines to the seabed.

The requirements for the assignment and maintenance of this notation are given respectively in Part E, Chapter 12 and in Ch 4, Sec 8, [19].

4.9.8 Cable laying ship

In compliance with [4.9.3] the service notation **cable laying** is assigned to ships specially equipped for the carriage and/or laying, hauling and repair of submarine cables. The additional requirements of Ch 4, Sec 8, [11] and Part E, Chapter 6 are applicable to these ships.

4.9.9 Standby and rescue vessel

In compliance with [4.9.4], ships complying with the requirements of Part E, Chapter 10 are eligible for the assignment of the service notation **standby rescue**.

This service notation may be completed by the number of survivors that the vessel is intended to carry. Depending on the vessel operation area, the Society may adapt the requirements regarding the survivors accommodation and/or the safety equipment. In such a case, this service notation is to be completed by the number of survivors that the vessel is intended to carry and by the vessel operation area, as for example: **standby rescue (150 survivors, Guinea Gulf)**.

The additional requirements of Ch 4, Sec 8, [15] are applicable to these ships.

4.9.10 Supply vessel

In compliance with [4.9.4] the service notation **supply** is assigned to ships intended to support offshore operations by carrying deck cargoes and oil products (MARPOL Annex 1) in bulk with flash point not less than 60°C, cement, dry mud and non-hazardous liquid mud in underdeck tanks.

Where applicable, the service notation **supply** is to be completed by one or several of the following additional service features:

- **WELLSTIM**, for well stimulation vessels
- **HNLS**, for ships, other than well stimulation vessels, carrying hazardous and noxious substances in bulk for the servicing and resupplying of offshore platforms, mobile offshore drilling units and other offshore installations, including those employed in the search for and recovery of hydrocarbons from the sea-bed.

The additional service features **HNLS** and **WELLSTIM** are to be completed by one or several of the following notations when carriage of products mentioned below is considered:

- **-FP≤60°C**: when ship may carry products with a flash point equal to or less than 60°C
- **-toxic**: when ship may carry toxic products
- **-acids**: when ship may carry acid products.
- **-LG**: when ship may carry liquid carbon dioxide and liquid nitrogen.

The additional requirements of Ch 4, Sec 8, [7] and Part E, Chapter 3 are applicable to these ships.

4.10 Non-propelled units, assisted propulsion units and other units

4.10.1 Barge

The service notation **barge** is assigned to non-propelled units intended to carry, inside holds or tanks, dry or liquid cargo except liquefied gases or other substances listed in Pt D, Ch 9, Sec 1.

The additional requirements of Part D, Chapter 14 are applicable to these ships.

For ships intended to carry only one type of cargo, the service notation may be completed by an additional service feature indicating the type of product carried e.g. **barge - oil**, **barge - general cargo**, **barge - chemical**.

This service notation may be completed by the additional service feature **tug combined** when the units are designed to be connected with tugs and comply with the relevant requirements of Pt E, Ch 1, Sec 4. The tugs to which the barge can be connected are specified in a memoranda.

4.10.2 Pontoon

The service notation **pontoon** is assigned to non-propelled units intended to carry cargo and/or equipment on deck only. When a crane is permanently fitted on board, the crane is to be certified and the service notation **pontoon - crane** is granted. The additional requirements of Part D, Chapter 14 are applicable to these ships.

4.10.3 Other units

Any non-propelled units other than those covered by the service notations listed in [4.10.1] and [4.10.2] will be assigned the additional service feature **no propulsion**, to be added to their own service notation, e.g. **dredger - no propulsion**.

4.10.4 Assisted propulsion units

Any units having a propulsion system not enabling them to proceed at a speed greater than 7 knots, used for short transit voyages, will be assigned the additional service feature **assisted propulsion** to be added to their own service notation, e.g. **dredger - assisted propulsion**.

4.10.5 Floating dock

The service notation **floating dock** is assigned to floating docks meeting the requirements of NR475.

Note 1: The navigation notation **sheltered area** is assigned to these units. When the dock is intended to be towed, the navigation notation **temporary unrestricted navigation** is also to be assigned.

4.11 Fishing vessels

4.11.1 The service notation **fishing vessel** is assigned to ships specially equipped for catching and storing fish or other living resources of the sea. The additional requirements of Ch 4, Sec 8, [14] and Part D, Chapter 15 are applicable to these ships.

The service notation may be completed by the following additional service feature, as applicable:

- **F**, when the ship complies with the requirements of Pt D, Ch 15, Sec 6 related to fire prevention, ventilation systems and means of escape
- **TORRE**, when the Society has verified the compliance with the requirements for construction and equipment of fishing vessels of the Torremolinos International Convention for the Safety of Fishing Vessels, as amended
- **ED**, when the Society has verified the compliance with the requirements for construction and equipment of fishing vessels of the European Directive 97/70/EC, as amended.

Note 1: Units solely dedicated to service in a fishing flotilla by means of cold storage and/or transformation of fish are not covered by the service notation **fishing vessel**. They will be considered with the service notation **special service**.

4.12 High speed crafts (HSC)

4.12.1 The high speed crafts meeting the requirements of the Rules for the Construction and the Classification of High Speed Craft (NR396 UNITAS) are assigned the following service notations:

- For passenger ships which do not proceed in the course of their voyage more than four hours at operational speed from a place of refuge:
 - **HSC-CAT A** (or **high speed craft-CAT A**) for passenger ships defined as "Category A craft" in respect of the IMO International Code of Safety for High Speed Craft
 - **HSC-CAT B** (or **high speed craft-CAT B**) for passenger ships defined as "Category B craft" in respect of the IMO International Code of Safety for High Speed Craft
- For ships other than passenger ships and which do not proceed in the course of their voyage more than 8 h at operational speed from a place of refuge when fully laden:
 - **HSC** (or **high speed craft**)

The type of service may be specified after the notation.

4.12.2 The service notation **light ship** is assigned to ships subject to compliance both with Chapter 3 and Chapter 6 of NR396 UNITAS Rules for the Classification of High Speed Craft, and with:

- for ships more than 500 GT: Part B and Part C of the present Rules, regarding stability and machinery installation
- for ships less than 500 GT: NR566 Hull Arrangement, Stability and Systems for Ships less than 500 GT.

The type of service may be specified after the service notation, i.e.:

light ship/fast passenger vessel

light ship/fast cargo vessel

light ship/fast patrol vessel.

These ships which are likely to operate at sea within specific limits may, under certain conditions, be granted an operating area notation. For the definition of operating area notation, reference should be made to [5.3].

4.13 Ships with low flashpoint liquid or gas fuelled propulsion

4.13.1 The service notation is to be completed by one or more of the following additional service features, as applicable:

- **LNGfuel**, for ships fitted with engines or gas turbines using natural gas as fuel, stored in liquefied form
- **CNGfuel**, for ships fitted with engines or gas turbines using compressed natural gas as fuel
- **LPGfuel**, for ships fitted with engines or gas turbines using liquefied petroleum gas as fuel, in liquefied or gaseous form
- **methanolfuel**, for ships fitted with engines or gas turbines using methanol as fuel
- **ammoniafuel**, for ships fitted with engines or gas turbines using ammonia as fuel
- **LFPfuel**, for ships fitted with engines or gas turbines using a low flash-point fuel different from the fuels mentioned above.

Note 1: Natural gas means gaseous mixture consisting mainly of methane and which may also contain smaller amounts of ethane, propane and butane.

Note 2: Petroleum gas means gaseous mixture consisting mainly of propane and butane.

Each additional service feature is to be completed by one of the following notations:

- **singlefuel** for ships fitted with engines or gas turbines using only the fuel considered
- **dualfuel** for ships fitted with engines or gas turbines using both the fuel considered and fuel oil.

The notations **singlefuel** or **dualfuel** may be completed by:

- **-aux**, when the ship uses the fuel considered only for the generating set
- **-prop**, when the ship uses the fuel considered only for the propulsion system.

Note 3: **-aux** and **-prop** are not added to **singlefuel** or **dualfuel** when both auxiliaries and propulsion are using the same fuel considered.

The requirements for the assignment of these additional service features are given in:

- Pt D, Ch 9, Sec 1, [1.1.6] for gas carriers
- NR529 Gas-fuelled Ships
- NI 647 LPG-fuelled Ships
- NR670 Methyl/ethyl alcohol Fuelled Ships
- NR671 Ammonia-fuelled Ships.

The additional requirements of Ch 4, Sec 9 are applicable to these ships, except gas carriers using their cargo as fuel, for which the applicable requirements are given in Ch 4, Sec 5.

The additional service feature **LFPfuel** is assigned to ships fitted with engines or gas turbines using a low flash-point liquid fuel or gas different from the fuels mentioned above when this has been specially considered by the Society.

Examples:

CNGfuel singlefuel -prop

ammoniafuel dualfuel

methanolfuel dualfuel -aux LNGfuel singlefuel -prop

4.13.2 Ships fitted with a fuel cell power installation

The additional service feature **fuelcell** is to be assigned to ships fitted with a fuel cell power installation.

The requirements for the assignment of this additional service feature are given in NI 547 Guidelines for fuel cell systems onboard commercial ships.

The additional requirements of Ch 4, Sec 9 are applicable to these ships, except gas carriers using their cargo as fuel, for which the applicable requirements are given in Ch 4, Sec 5.

4.14 Icebreaker ships

4.14.1 The service notation **Icebreaker** is assigned to ships having an operational profile that includes escort or ice management functions, having powering and dimensions that allow them to undertake independent operations in ice covered waters.

The service notations dealt with under [4.14.2] are relevant to ships intended for navigation in ice-infested polar waters.

The requirements for the assignment of these service notations are given in NR527 Rules for the Classification of POLAR CLASS and ICEBREAKER Ships.

Ships complying with the requirements of NR527 and assigned with one of the additional service notations **Icebreaker** are also to comply with the requirements for the assignment of the additional class notation defined in [6.14.12]: **COLD (H t_{DH}, E t_{DE})**.

4.14.2 The following service notations are assigned:

- **Icebreaker 1** for summer/autumn operations without restrictions and for winter/spring operations in multi-year ice with 3,0 m max ice thickness
- **Icebreaker 2** for summer/autumn operations in multi-year ice with 3,0 m max ice thickness and for winter/spring operations in second-year ice with 2,5 m max ice thickness
- **Icebreaker 3** for summer/autumn operations in second-year ice with 2,5 m max ice thickness and for winter/spring operations in thick first-year ice with 1,8 m max ice thickness
- **Icebreaker 4** for summer/autumn operations in thick first-year ice with 1,8 m max ice thickness and for winter/spring operations in medium first-year ice with 1,2 m max ice thickness

- **Icebreaker 5** for summer/autumn operations in medium first-year ice with 1,2 m max ice thickness and for winter/spring operations in medium first-year ice with 1,0 m max ice thickness
- **Icebreaker 6** for summer/autumn operations in medium first-year ice with 1,0 m max ice thickness and for winter/spring operations in medium first-year ice with 0,8 m max ice thickness
- **Icebreaker 7** for summer/autumn operations in medium first-year ice with 0,8 m max ice thickness and for winter/spring operations in thin first-year ice with 0,6 m max ice thickness.

4.15 Elastic shaft alignment for line shafting and structure compatibility

4.15.1 Elastic shaft alignment (ESA)

The additional service feature **ESA** is to be assigned to new ships designed with propulsion shaft line(s) falling into the categories as defined in NR592 Elastic Shaft Alignment (ESA).

The criteria and requirements for the assignment of this additional service feature are given in NR592.

4.16 Miscellaneous units

4.16.1 Special service

The service notation **special service** is assigned to ships which, due to the peculiar characteristics of their activity, are not covered by any of the notations mentioned above. The classification requirements of such units are considered by the Society on a case by case basis.

This service notation may apply, for instance, to ships engaged in research, expeditions and survey, ships for training of marine personnel, whale and fish factory ships not engaged in catching, ships processing other living resources of the sea, and other ships with design features and modes of operation which may be referred to the same group of ships.

An additional service feature may be specified after the notation (e.g. **special service-training, special service-fish factory**) to identify the particular service in which the ship is intended to trade. The scope and criteria of classification of such units are indicated in a memoranda.

4.16.2 Launch

The launches or motorboats with a length not exceeding 24 m and meeting the requirements of both NR566 Hull Arrangement, Stability and Systems for Ships less than 500 GT and NR600 Hull Structure and Arrangement for the Classification of Cargo Ships less than 65 m and Non Cargo Ships less than 90 m are assigned the following service notations:

- **seagoing launch**, for units intended for seagoing service, limited at a wind force not exceeding 6 Beaufort scale
- **launch**, for units intended for operation in ports, roadsteads, bays and generally calm stretches of water, limited at a wind force not exceeding 4 Beaufort scale.

Note 1: Ships that are assigned the service notation **launch** or **seagoing launch** are not assigned a navigation notation.

4.16.3 Yacht and charter yacht

The service notation **yacht** or **charter yacht** is assigned to ship intended for pleasure cruising, as follows:

- **yacht**, when the ship is not engaged in trade
- **charter yacht**, when the ship is engaged in trade.

The service notation **yacht** or **charter yacht** is always completed by one of the following additional service features, as applicable:

- **motor** for units propelled by propulsion engine
- **sailing** for units with a sail propulsion, including those assisted by auxiliary propulsion engine.

Examples:

yacht-motor

yacht-sailing

charter yacht-motor

charter yacht-sailing

The service notation **yacht** or **charter yacht** is always completed by one of the additional service feature, as applicable:

- **S** when the hull is made of steel material
- **C** when the hull is made of composite material
- **A** when the hull is made of aluminium
- **W** when the hull is made of wood material.

Example:

yacht-motor-S

The requirements for the assignment of these notations are given in NR 500, Rules For The Classification and the Certification of Yachts.

The requirements for the maintenance of these notations are given in NR 500, Rules For The Classification and the Certification of Yachts and in Ch 4, Sec 8, [16].

4.16.4 Crew boats

The service notation **crew boat** is assigned to ships less than 500 GT, dedicated to transport of offshore personnel from harbours to moored offshore installations or ships, proceeding in the course of their voyage not more than four hours at operational speed from a place of refuge, and meeting the requirements of NR490, Rules for the Classification of Crew Boats.

Ships which do not fulfil the minimum speed criteria given in NR490, Sec 1, [1], are not to be assigned the above service notation.

These ships which are likely to operate at sea within specific limits may, under certain conditions, be granted an operating area notation. For the definition of operating area notation, reference should be made to [5.3].

4.16.5 Compressed natural gas carrier

The service notation **compressed natural gas carrier** is assigned to ships intended to carry compressed natural gas (CNG) meeting the requirements of NR517 Classification of Compressed Natural Gas Carriers.

4.16.6 Wind farms service ship

The service notation **wind farms service ship - Xi** is intended to cover ships specifically designed to operate in offshore wind farms for the typical following duties:

- transfer of personnel from shore to offshore wind farms or from mother ships or accommodation units at site to offshore wind farms
- lifting operations required for wind turbines assistance (transfer of materials on wind turbines platforms).

The service notation is to be completed by the additional service feature **Xi**, where:

X : Capacity parameter having one of the following values: **S**, **M**, or **L**

i : Type ship parameter having one of the following values: **0**, **1** or **2**.

The requirements for the assignment of this service notation are given in the Rule Note NR589 Wind Farms Service Ships.

4.16.7 Offshore patrol vessel (OPV)

The service notation **OPV** is assigned to ships dedicated to patrol mission (i.e. smuggling, fishery inspection, customs-boarders protection...), with light weapon system and generally with no operational limit (neither weather condition restriction nor HS restriction). These ships could patrol at either low or high speed.

The additional requirements of Part D, Chapter 16 are applicable to these ships.

Note 1: For patrol craft operating only at high speed, the service notation **light ship/fast patrol vessel** is to be assigned in lieu of the notation **OPV** and relevant rules as stated in [4.12.2] and [5.2.8] apply.

4.16.8 Semi-submersible cargo ship

The service notation **semi-submersible cargo ship** is assigned to ships intended to perform loading and unloading operations of a floating cargo by submersion of the freeboard deck in accordance with the requirements Part E, Chapter 9.

The service notation **semi-submersible cargo ship** is completed by the additional service feature **heavycargo [AREA 1, X1 kN/m2 - ...]** as defined in [4.17.4].

One of the additional class notations **LI-HG-S2** or **LI-HG-S3** is to be assigned.

The service notation **semi-submersible cargo ship** is always completed by the additional class notation **SDS**.

The additional requirements of Ch 4, Sec 8, [17] are applicable to these ships.

4.16.9 FSRUs and FSUs

The requirements for the assignment of a service notation for Floating Storage Regasification Units (FSRUs) and Floating gas Storage Units (FSUs) are given in Rule Note NR645 Rules for the Classification of Floating Storage Regasification Units and Floating gas Storage Units.

The following service notations may be assigned to FSRUs and FSUs, as relevant:

- **liquefied gas carrier - FSRU**, when the floating unit is designed to operate as a regasification unit with the possibility of trading LNG in a navigation mode
- **liquefied gas carrier - FSU**, when the floating unit is designed to operate as a storage unit with the possibility of trading LNG in a navigation mode
- **FSRU**, when the floating unit is designed to operate as a regasification unit permanently moored without trading LNG
- **FSU-LNG**, when the floating unit is designed to operate as a storage unit permanently moored without trading LNG.

Note 1: Typical notations to be assigned to complete the service notations are described in NR645.

These service notations are to be completed by the additional service feature ([**cargo type**], [**ship type - IGC Code**], [**cargo tank design pressure**], [**minimum temperature**]) as defined in [4.4.5].

The requirements for the maintenance of these notations are given in NR645 and in:

- Ch 4, Sec 5, for units granted with **liquefied gas carrier - FSRU** or **liquefied gas carrier - FSU** notation
- NR445 Rules for the Classification of Offshore Units, for units granted with **FSRU** or **FSU-LNG** notation,

as applicable.

4.16.10 Other units

For ships or other floating units intended to be classed with other service notations, reference is to be made to the specific Rules of the Society, and in particular:

- Rules for the Classification of Naval Ships (NR483)
- Rules for the Classification of Offshore Units (NR445)

4.16.11 Inland navigation vessels

For ships and units intended for navigation in inland waters, reference is to be made to the Rules and Regulations for the Construction and Classification of Inland Navigation Vessels (NR217).

4.17 Miscellaneous service features

4.17.1 Special purpose ships (SPxxx)

Ships complying with the IMO Code of Safety for Special Purpose Ships carrying more than twelve (12) special personnel are to be assigned the additional service feature **SPxxx**, where **xxx** is the total number of persons onboard including crew, special personnel and passengers (maximum twelve).

The requirements for the assignment of this additional service feature consist of:

- the general requirements of the present Rules, and

- the additional requirements given in:
 - Pt B, Ch 2, Sec 1; Pt B, Ch 2, Sec 2; Pt B, Ch 3, Sec 1; Pt B, Ch 3, Sec 3 and Pt B, Ch 3, App 2 for stability
 - Pt C, Ch 1, Sec 10 and Pt C, Ch 1, Sec 11 for machinery and systems
 - Pt C, Ch 2, Sec 3 for electrical installations and automation, and
 - Pt C, Ch 4, Sec 1 for fire protection, detection and extinction.

The additional service feature **SPxxx** is to be completed by the additional service feature **SRTP** when:

- **xxx** is greater than 240 and
- L_{LL} as defined in Pt B, Ch 1, Sec 2, [3.2] is greater than or equal to 120 m or the ship includes three or more main vertical zones as defined in Pt C, Ch 4, Sec 1, [3.25].

4.17.2 Tier III

The additional service feature **Tier III** is assigned to ships for which the main engine and auxiliary engines are issued with an EIAPP certificate (Engine International Air Pollution Prevention Certificate) stating compliance with Tier III according to the applicable Marpol Convention requirements.

4.17.3 Ships operating in polar waters

The following additional service features are assigned to ships which are in compliance with the corresponding ship category according to the IMO International Code for Ships Operating in Polar Waters (Polar Code):

- **POLAR CAT-A** for ships defined as "Category A" ships in respect of the IMO International Code for Ships Operating in Polar Waters
- **POLAR CAT-B** for ships defined as "Category B" ships in respect of the IMO International Code for Ships Operating in Polar Waters
- **POLAR CAT-C** for ships defined as "Category C" ships in respect of the IMO International Code for Ships Operating in Polar Waters.

The requirements for the assignment of these additional service features are detailed in NR527, Rules for the Classification of Ships Operating in Polar Waters and Icebreakers.

4.17.4 Carriage of heavy cargo

When the double bottom and/or hatch covers and/or other cargo areas designed to support heavy cargoes fulfil the appropriate rule requirements, the additional service feature **heavycargo** [AREA1, X1 kN/m² - AREA2, X2 kN/m² - ...] may complete the service notation of a ship. The values Xi indicate the maximum allowable local pressures on the various zones AREAi where the cargo is intended to be stowed.

The requirements for the assignment of this additional service feature are given in Pt B, Ch 5, Sec 6, [4.1.2].

4.17.5 Computerized systems

The additional service feature **SW-Registry** is assigned to ships contracted for construction on or after 1st July 2017, provided with a software registry meeting the related requirements laid down in Pt C, Ch 3, Sec 3 for the assignment and those laid down in Ch 3, Sec 1 and Ch 3, Sec 3 for the maintenance of the software registry.

This additional service feature **SW-Registry** is assigned to existing ships provided with a software registry in compliance with the related requirements laid down in Pt C, Ch 3, Sec 3; requirements for the maintenance of the notation are indicated in Ch 3, Sec 1 and Ch 3, Sec 3.

4.17.6 Coating performance standard

The additional service feature **CPS(WBT)** is assigned to the following ships:

- bulk carriers assigned with the additional service feature **CSR** and contracted for construction on or after 8 December 2006, for which the rule requirements of NR530 Coating Performance Standard, applicable to ships complying with the requirements of the Common Structural Rules for Bulk Carriers or the Common Structural Rules for Double Hull Oil Tankers and related to protective coatings in dedicated seawater ballast tanks of ships of not less than 500 gross tonnage and double-side skin spaces arranged in bulk carriers of length greater than or equal to 150 m, are applied
- oil tankers assigned with the additional service feature **CSR** and contracted for construction on or after 8 December 2006, for which the rule requirements of NR530 Coating Performance Standard, applicable to ships complying with the requirements of the Common Structural Rules for Bulk Carriers or the Common Structural Rules for Double Hull Oil Tankers and related to protective coatings in dedicated seawater ballast tanks of ships of not less than 500 gross tonnage and double-side skin spaces arranged in bulk carriers of length greater than or equal to 150 m, are applied
- ships complying with IMO resolution MSC.215(82), as amended, and contracted for construction on or after 1 July 2008.

Note 1: For other ships complying with the requirements of NR530 Coating Performance Standard, reference is made to [6.15.4] for the possible assignment of the additional class notation **CPS(WBT)**.

4.17.7 Power generation

The additional service features:

- **POWERGEN(OIL)**
- **POWERGEN(LNG/NG)**
- **POWERGEN(DUALFUEL)**

are assigned to units fitted with power generation equipment to serve as a power generation resource.

The requirements for the assignment of these additional service features are given in NR656.

4.17.8 Smart systems

The additional service feature **SMART()** is assigned to ships fitted with computerized based system that incorporate functions for the collection, the transmission, the analysis and the visualisation of data.

These smart functions may be related to operation or maintenance of ships and may include monitoring, decision making support, remote monitoring, maintenance from shore or remote operation of systems.

The additional service feature **SMART()** is completed by at least one of the following notations:

- **H1** or **H2**, for smart functions related to hull items
- **M1** or **M2** for smart function related to machinery items
- **N1** or **N2** for smart functions related to navigation systems.

Examples:

SMART(H1)

SMART(M2, N2)

Granting of a notation **H1** or **H2**, **M1** or **M2** and **N1** or **N2** is subject to compliance with the requirements for the assignment of specific additional class notations and/or additional service features, as defined in NR675 "Additional service feature **SMART()**".

Note 1: When granting the additional service feature **SMART()**, a memoranda is to be endorsed in order to record the smart functionalities considered, specifying the additional class notations, additional service features and any other digital solutions considered in the scope of the granted additional service feature **SMART()**.

The requirements for the assignment of the additional service feature **SMART()** are given in NR675.

The requirements for the maintenance of the additional service feature **SMART()** are those corresponding to:

- each additional class notation or additional service feature assigned in association with notations **H1** or **H2**, **M1** or **M2** and **N1** or **N2**
- and/or requirements laid down in Ch 3, Sec 1, [3.3] or Ch 3, Sec 3, [3.6] as applicable for notations using computer based systems.

4.17.9 Condition based maintenance

The additional service features **CBM** and **[CBM]** are assigned to ships where a Planned Maintenance Survey system for machinery (PMS) is implemented and on which at least one machinery item is to be surveyed under a Condition Based Maintenance scheme, according to the requirements of Ch 2, Sec 2, [4.4] and Ch 2, App 4.

The additional service feature **[CBM]** is assigned to ships prior to an implementation survey to be carried out under the conditions specified in Ch 2, App 4, [3.2].

The additional service feature **[CBM]** is replaced by **CBM** when the implementation survey is carried out and found in order.

The requirements for the assignment and maintenance of these additional service features are given in Ch 2, App 4.

5 Navigation and operating area notations

5.1 Navigation notations

5.1.1 Every classed ship is to be assigned one navigation notation as listed in [5.2], except those with the service notations **launch** or **seagoing launch**.

5.1.2 The assignment of a navigation notation, including the reduction of scantlings or specific arrangements for restricted navigation notations, is subject to compliance with the requirements laid down in Part B, Part C, Part D and Part E of the Rules and in NR216 Materials and Welding.

5.1.3 The assignment of a navigation notation does not absolve the Interested Party from compliance with any international and national regulations established by the Administrations for a ship operating in national waters, or a specific area, or a navigation zone. Neither does it waive the requirements in Ch 1, Sec 1, [3.3.1].

5.2 List of navigation notations

5.2.1 The navigation notation **unrestricted navigation** is assigned to a ship intended to operate in any area and any period of the year.

5.2.2 The navigation notation **summer zone** is assigned to ships intended to operate only within the geographical limits as defined in ILLC 1966 for the Summer zones.

5.2.3 The navigation notation **tropical zone** is assigned to ships intended to operate only within the geographical limits as defined in ILLC 1966 for the Tropical zones.

5.2.4 The navigation notation **coastal area** is assigned to ships intended to operate only within 20 nautical miles from the shore and with a maximum sailing time of six hours from a port of refuge or safe sheltered anchorage.

5.2.5 The navigation notation **sheltered area** is assigned to ships intended to operate in sheltered waters, i.e. harbours, estuaries, roadsteads, bays, lagoons and generally calm stretches of water and when the wind force does not exceed 6 Beaufort scale.

5.2.6 In specific cases, the designation of the geographical area and/or the most unfavourable sea conditions considered may be added to the navigation notation.

5.2.7 The navigation notation **temporary unrestricted navigation** may be assigned, in addition to the navigation notations defined in [5.2.2], [5.2.3], [5.2.4] and [5.2.5] to service ships for which the period of unrestricted navigation may be chosen to satisfy the conditions defined in a memoranda.

When a favourable weather situation is included amongst these conditions, the voyages are to be such as the ship can be put in a port or a sheltered anchorage in about 12 hours from any point of its route.

Note 1: Before any voyage covered by the navigation notation **temporary unrestricted navigation**, the ship is to be submitted to an occasional survey, during which the Surveyor checks that the intended voyage and the ship's specific condition, if any, comply with the conditions defined in a memoranda.

5.2.8 For ships assigned with the service notation:

- **HSC-CAT A, HSC-CAT B, or HSC** as defined in [4.12.1]
- **light ship**, as defined in [4.12.2], or
- **crew boat**, as defined in [4.16.4]
- **wind farm service ship - X0**, as defined in [4.16.6],

as a rule, one of the following navigation notations is to be assigned to such units and is corresponding to sea areas where the significant wave height H.S. is not to exceed for more than 10 per cent of the year the following values:

- **sea area 1:** 0,5 m
- **sea area 2:** 2,5 m
- **sea area 3:** 4,0 m
- **sea area 4:** no limitation.

The shipyard's table of the maximum allowed ship speed relative to the sea states, characterised by their significant wave height, is indicated in a memoranda.

5.3 Operating area notations

5.3.1 The operating area notation expresses the specified area where some service units are likely to operate at sea within specific restrictions which are different from normal navigation conditions.

The operating area notations defined in [5.3.2] are, in principle, solely granted to ships for dredging activities as defined in [4.6].

The operating area notations defined in [5.3.3] are, in principle, solely granted to tugs as defined in [4.7].

The operating area notation defined in [5.3.4] is, in principle, solely granted to crew boats, wind farms service ships and light ships as defined, respectively, in [4.16.4], [4.16.6] and [4.12.2].

This operating area notation is indicated after the navigation notation.

Example:

unrestricted navigation - "operating area notation"

5.3.2 Operating areas for dredgers

The following operating area notations may be assigned:

- **dredging within 8 miles from shore**
- **dredging within 15 miles from shore or within 20 miles from port**
- **dredging over 15 miles from shore.**

The operating area of the first two categories as specified in [4.6] may be extended respectively over 8 or 15 miles. In that case, the operating area notation is completed by the maximum significant wave height during service, as follows:

dredging over 8 (or 15) miles from shore with H.S. ≤ ... m.

For ships being assigned the service notation **split hopper unit** or **split hopper dredger**, the operating area notation may be completed by the maximum allowable significant height of waves during the service, being indicated between parenthesis, i.e. (H.S. ≤ ... m).

5.3.3 Operating areas for tugs

The following operating area notations may be assigned:

- **operating within 5 miles from shore** for ships granted with the service notation **tug** or **escort tug** which are specially equipped to assist ships and/or floating units while entering or leaving port, within 5 miles from shore, and limited to operate from a single and fixed port.

- **operating ≤ 4h from a place of refuge** for ships granted with the service notation **tug** or **escort tug** which do not proceed in the course of their voyage for more than four hours at operational speed from any naturally or artificially sheltered area which may be used as a shelter by the tug under conditions likely to endanger its safety.
- **escort service limited to non-exposed waters** for ships granted with the service notation **escort tug** which are operating in non-exposed waters, where the environmental impact on the escort service is negligible. In general, waters are considered as non-exposed where the wind fetch is not more than 6 nautical miles and the significant wave height is not more than 1,0 m.

5.3.4 Operating area for crew boats, wind farms service ships and light ships

The following operating area notation may be assigned to ships with service notation **crew boat**, **wind farms service ships** or **light ship**:

- **assisted operating area** for ships operating within an area where it has been demonstrated to the satisfaction of the Society that there is a high probability that in the event of an evacuation at any point of the route, all passengers and crew can be rescued safely within 4 hours. For ships operating in harsh environmental conditions, a reduced time of rescue may be required to the satisfaction of Society.

The operating area is to be specified by the party applying for classification and is to be indicated in a memoranda.

6 Additional class notations

6.1 General

6.1.1 An additional class notation expresses the classification of additional equipment or specific arrangement, which has been requested by the Interested Party.

6.1.2 The assignment of such an additional class notation is subject to the compliance with additional rule requirements, which are detailed in Part F of the Rules.

6.1.3 Some additional class notations are assigned a construction mark, according to the principles given in [3.1.2]. This is indicated in the definition of the relevant additional class notations.

6.1.4 The different additional class notations which may be assigned to a ship are listed in [6.2] to [6.15], according to the category to which they belong. These additional class notations are also listed in alphabetical order in Tab 3.

Table 3 : List of additional class notations

Additional class notation	Definition in	Reference in NR 467 or to other Rule Notes	Remarks
ACCESS	[6.14.29]	Pt F, Ch 11, Sec 19	
ALM (ALM) ALM-EN ALM-SUBSEA ALP (ALP)	(1) (1) (1) (1) (1) (1)	[6.12] NR 526	ALP , ALM , ALM-EN and ALM-SUBSEA may be completed by -MR
AMMONIA-PREPARED	[6.14.54]	Pt F, Ch 11, Sec 35	AMMONIA-PREPARED may be completed between brackets by 1 to 5 of the following notations: S , T , H , P , B
AUT-CCS	(1)	[6.4.3]	Pt F, Ch 3, Sec 2
AUT-IMS	(1)	[6.4.5]	Pt F, Ch 3, Sec 4
AUT-PORT	(1)	[6.4.4]	Pt F, Ch 3, Sec 3
AUT-UMS	(1)	[6.4.2]	Pt F, Ch 3, Sec 1
AVM-APS	(1)	[6.3.2]	Pt F, Ch 2, Sec 1
AVM-DPS	(1)	[6.3.3]	Pt F, Ch 2, Sec 2
AVM-IPS	(1)	[6.3.4]	Pt F, Ch 2, Sec 3
AVM-FIRE	(1)	[6.3.5]	Pt F, Ch 2, Sec 4
AWT-A AWT-B AWT-A/B		[6.8.4]	Part F, Chapter 9
BATTERY SYSTEM	[6.14.36]	Pt F, Ch 11, Sec 21	
BIORISK MANAGED BIORISK SECURED	[6.14.50]	Pt F, Ch 11, Sec 31	

Additional class notation	Definition in	Reference in NR 467 or to other Rule Notes	Remarks
BLUS SLUS	[6.14.24]	Pt F, Ch 11, Sec 17	
BWE	[6.8.5]	Part F, Chapter 9	
BWT	[6.8.6]	Part F, Chapter 9	
CARGOCONTROL	[6.14.9]	Pt F, Ch 11, Sec 9	
CBRN CBRN-WASHDOWN	[6.14.39]	Part F, Chapter 10	
CLEANSHIP	[6.8.2]	Part F, Chapter 9	CLEANSHIP and CLEANSHIP SUPER () may be completed by CEMS .
CLEANSHIP SUPER ()	[6.8.3]		between brackets, at least 3 eligible notations are to be assigned among the following ones: AWT-A , AWT-B , AWT-A/B , BWT , EGCS-SCRUBBER , GWT , HVSC , NDO -x days , NOX-x% , OWS-x ppm , SOX-x%
COLD CARGO	[6.14.13]	Pt F, Ch 11, Sec 11	
COLD DI COLD (H t_{DH}, E t_{DE})	[6.14.12]	Pt F, Ch 11, Sec 11	
COMF+	[6.7.4]	Part F, Chapter 6	COMF+ is to be complemented by the selected performance indexes (Sound insulation index/ Impact index/ Emergence/ Intermittent noise/ Intelligibility) grade y is equal to 1, 2, or 3 grade y' is equal to 1, 2, 3, 1PK, 2PK or 3PK COMF notations may be completed by -SIS .
COMF-NOISE y	[6.7.2]		
COMF-VIB y'	[6.7.3]		
COMF-NOISE-Crew y COMF-NOISE-Pax y COMF-VIB-Crew y' COMF-VIB-Pax y'	[6.7.5]		
COVENT	[6.14.8]		
CPS(COT)	[6.15.6]	NR 530	cargo oil tanks of crude oil tankers of 5 000 tonnes deadweight (DWT) and above
CPS(VSP)	[6.15.5]	NR 530	
CPS(WBT)	[6.15.4]	NR 530	on a voluntary basis for ships other than bulk carriers CSR or oil tankers CSR contracted for construction on or after 8 December 2006
CYBER MANAGED CYBER MANAGED PREPARED	[6.14.43]	NR 659	
CYBER SECURE (1) CYBER SECURE PREPARED (1)	[6.14.43]	NR 659	
DYNAPOS SAM (1) DYNAPOS AM (1) DYNAPOS AT (1) DYNAPOS AM/AT (1)	[6.14.6]	Pt F, Ch 11, Sec 6	DYNAPOS AM and DYNAPOS AT may be completed by R or RS DYNAPOS AM/AT may be completed by R or RS or (xx ; xx) (corresponding to the two-number vector for the Environmental Station Keeping Index ESKI) DYNAPOS notations may be completed by -HWIL DYNAPOS AM/AT-R or DYNAPOS AM/AT-RS may be completed by -EI DYNAPOS notations may be completed by -DDPS
ECFP-1 ECFP-2 ECFP-3	[6.14.48]	Pt F, Ch 11, Sec 30	ECFP-2 and ECFP-3 are to be complemented by the notation (Area 1, X_{1m} ; ... ; Area n, X_{nm})
EFP-A EFP-M EFP-C EFP-AMC	[6.14.18]	Pt F, Ch 11, Sec 15	
EGCS-SCRUBBER	[6.8.12]	Part F, Chapter 9	

Additional class notation	Definition in	Reference in NR 467 or to other Rule Notes	Remarks
ELECTRIC HYBRID ()	[6.14.40]	Pt F, Ch 11, Sec 22	between brackets, at least 1 eligible notation is to be assigned among the following ones: PM, PB, ZE
ELECTRIC HYBRID PREPARED ()	[6.14.45]	Pt F, Ch 11, Sec 29	between brackets, at least 1 eligible notation is to be assigned among the following ones: PM, PB, ZE
ERS-H ERS-M ERS-S [ERS-H] [ERS-M] [ERS-S]	[6.13.2]	NR 556	
ESA	[6.14.30]	NR 592	
ETA	[6.15.3]	Pt B, Ch 9, Sec 4, [3]	
EWCT	[6.14.15]	Pt F, Ch 11, Sec 12	
FORS	[6.14.19]	NR 553	this notation may be complemented by the notation - NS
FSRU READY	[6.14.53]	Pt F, Ch 11, Sec 33	between brackets, the notation may be complemented by one, more or all of the following notations: P, R, I
GAS-PREPARED GAS-PREPARED ()	[6.14.35]	Pt F, Ch 11, Sec 25	between brackets, the notation may be complemented by one, more or all of the following notations: S, P, ME-DF, AE, B
GRAB [X]	[6.14.2]	NR 606 (2) NR 522, Ch 12	on a voluntary basis for bulk carriers other than CSR BC-A or CSR BC-B
GRABLOADING	[6.14.2] b)	Pt F, Ch 11, Sec 2	
GREEN PASSPORT GREEN PASSPORT EU	[6.14.14]	NR 528	
GWT	[6.8.7]	Part F, Chapter 9	
HABITABILITY	[6.14.26]	NI 577	
HEADING CONTROL-DS HEADING CONTROL-IS	[6.14.46]	Pt F, Ch 11, Sec 28	
HEL	[6.14.22]	Pt F, Ch 11, Sec 20	
HEL(Y)	[6.14.23]	NR 500	
HVSC	[6.14.20]	NR 557	
HYBRID MECHANICAL PROPULSION	[6.14.49]	Pt F, Ch 11, Sec 32	
IATP ()	[6.14.17]	Pt F, Ch 11, Sec 14	between brackets, this notation is to be complemented by one of the following notations: dual setting, boil-off or dual setting and boil-off .
ICE	[6.10.4]	Part F, Chapter 8	
ICE CLASS IA SUPER ICE CLASS IA ICE CLASS IB ICE CLASS IC	[6.10.2]		
ICE CLASS ID	[6.10.3]		
IG	[6.15.2]	Pt D, Ch 7, Sec 6 and Pt D, Ch 8, Sec 9	
INWATERSURVEY	[6.14.3]	Pt F, Ch 11, Sec 3	
LASHING LASHING-WW LASHING (specific area)	[6.14.5]	Pt F, Ch 11, Sec 5	

Additional class notation	Definition in	Reference in NR 467 or to other Rule Notes	Remarks
LI-HG LI-S1 LI-S2 LI-S3 LI-S4 LI-HG-S1 LI-HG-S2 LI-HG-S3 LI-HG-S4 LI-LASHING	[6.14.27]	Pt B, Ch 10, Sec 2	
MANOVR	[6.14.10]	Pt F, Ch 11, Sec 10	IMO Resolution MSC 137(76)
MOB	[6.14.44]	Pt F, Ch 11, Sec 27	
MON-HULL	[6.6.2]	Pt F, Ch 5, Sec 1	
MON-ICE	[6.6.4]	NR 616	MON-ICE is to be complemented by criteria L(i) , where i is a (list of) Roman numeral(s) from I to VII , or/and G
MON-SHAFT	[6.6.3]	Pt F, Ch 5, Sec 2	
NDO-x days	[6.8.8]	Part F, Chapter 9	
NOX-x%	[6.8.9]	Part F, Chapter 9	
OAS (1)	[6.14.38]	NI 629	
OHS (1)	[6.14.33]	NR 595	
OPEN-HATCH	[6.14.51]	Pt F, Ch 11, Sec 33	may be assigned to ships granted with the service notation general cargo ship
OWS-x ppm	[6.8.10]	Part F, Chapter 9	
PaRoll1 PaRoll2	[6.14.47]	NR 667	may be assigned to container ships
POLAR CLASS z	[6.11]	NR 527	z is equal to 1, 2, 3, 4, 5, 6 or 7
PROTECTED FO TANK	[6.14.16]	Pt F, Ch 11, Sec 13	
REF-CARGO (1)	[6.9.2]	Pt F, Ch 7, Sec 2	this notation may be complemented by the notations: -AIRCONT , -PRECOOLING and/or -QUICKFREEZE
REF-CONT (A) REF-CONT (E)	(1) [6.9.3] (1)	Pt F, Ch 7, Sec 3	these notations may be complemented by the notation -PRECOOLING and/or -QUICKFREEZE REF-CONT (A) may be complemented by the specific notation -AIRCONT
REF-STORE (1)	[6.9.4]	Pt F, Ch 7, Sec 4	this notation may be complemented by the specific notations -PRECOOLING and/or -QUICKFREEZE
SAFE-LASHING	[6.14.37]	–	
SAS	[6.14.25]	Pt F, Ch 11, Sec 18	
SDS	[6.14.11]	Pt B, Ch 3, Sec 3	
SCRUBBER READY	[6.8.14]	Pt F, Ch 11, Sec 24	
SEEMP	[6.8.13]	NR 586	
SINGLEPASSLOADING	[6.14.21]	Pt F, Ch 11, Sec 16	this additional class notation may be complemented by the design loading rate in tons per hour, for example: SINGLEPASSLOADING [xxxxx t/h]
SOX-x%	[6.8.11]	Part F, Chapter 9	as an alternative, equivalent arrangements (e.g. exhaust gas cleaning systems) may be accepted
Spectral Fatigue ()	[6.14.32]	NI 611	the information between brackets is a short description of routes and/or areas considered for the spectral fatigue analysis and associated design fatigue life
SPM	[6.14.4]	Pt F, Ch 11, Sec 4	
STABLIFT	[6.14.41]	Pt E, Ch 8, Sec 3	

Additional class notation	Definition in	Reference in NR 467 or to other Rule Notes	Remarks
STAB-WIND	[6.14.31]	NR 500	
STAR-CARGO (1)	[6.2.9]	Pt F, Ch 1, Sec 5	
STAR-REGAS (1)	[6.2.8]	Pt F, Ch 1, Sec 4	
STAR SIS (1)	[6.2.7]		the cumulative notation STAR SIS supersedes the notations STAR-HULL and STAR-MACH SIS
STAR-HULL (1)	[6.2.4]	Pt F, Ch 1, Sec 2	
STAR-MACH (1)	[6.2.5]	Pt F, Ch 1, Sec 3	
STAR-MACH SIS (1)	[6.2.6]	Pt F, Ch 1, Sec 3	
STRENGTHBOTTOM	[6.14.1]	Pt F, Ch 11, Sec 1	
SUSTAINABLESHIP-1 SUSTAINABLESHIP-2	[6.14.55]	Pt F, Ch 11, Sec 36	
SYS-COM (1)	[6.5.4]	Pt F, Ch 4, Sec 3	SYS-IBS can only be assigned to ships which are also assigned the notation SYS-NEQ SYS-IBS-1 can only be assigned to ships which are also assigned the notations SYS-NEQ-1 and AUT-UMS SYS-IBS and SYS-IBS-1 may be complemented by -HWIL
SYS-IBS (1)	[6.5.3]	Pt F, Ch 4, Sec 2	
SYS-IBS-1 (1)			
SYS-NEQ (1)	[6.5.2]	Pt F, Ch 4, Sec 1	
SYS-NEQ-1 (1)			
SYS-NEQ-OSV (1)	[6.5.5]	NR 633	
ULEV	[6.8.15]	Pt F, Ch 11, Sec 26	
UNSHELTERED ANCHORING	[6.14.42]	Pt F, Ch 11, Sec 23	
URN	[6.14.34]	NR 614	
VCS	[6.14.7]	Pt F, Ch 11, Sec 7	this notation may be complemented by the specific notation -TRANSFER (see [6.14.7])
VeriSTAR-HULL (1)	[6.2.2]	Pt F, Ch 1, Sec 1	these notations may be complemented by FAT or FAT xx years , with $25 \leq xx \leq 40$ (3)
VeriSTAR-HULL CM (1)	[6.2.3]		
VeriSTAR-HULL SIS (1)	[6.2.3]		
WhiSp1 WhiSp2 WhiSp3	[6.14.28]	NR 583	
WPS1 or WPS2 (1)	[6.14.52]	NR 206	
YOUNG ICE 1 YOUNG ICE 2	[6.10.3]	Part F, Chapter 8	
(1) A construction mark is added to this notation.			
(2) Bulk carriers and Oil Tankers assigned with the additional service feature CSR contracted for new construction on or after 1 July 2015 are to comply with the requirements of NR606 Common Structural Rules for Bulk Carriers and Oil Tankers.			
(3) For vessels contracted before 1st July 2016 the notation DFL xx years may have been assigned in lieu of FAT xx years .			

6.2 VeriSTAR and STAR notations

6.2.1 General

VeriSTAR and **STAR** notations integrate rational analysis at design stage or after construction and possibly with data and records from ships-in-service concerning planned inspection and ship maintenance.

In compliance with [6.1.3], these notations are assigned a construction mark, as defined in Article [3].

The requirements for the assignment of these notations are given in Part F, Chapter 1.

6.2.2 VeriSTAR-HULL CM and VeriSTAR-HULL

The additional class notation **VeriSTAR-HULL CM** may be assigned to new ships, contracted for construction on or after the 1st July 2015, the structural condition of which is

checked with 3D FEM calculation program at design stage, according to the requirements of the Society for which the hull surveys for new construction are carried out according to the requirements of Ch 3, Sec 7 and for which the requirements of Pt F, Ch 1, Sec 1 are fulfilled.

Existing ships contracted for construction before the 1st July 2015 and for which the structural condition is checked with 3D FEM calculation program at design stage according to the requirements of the Society may be assigned with the notation **VeriSTAR-HULL**.

VeriSTAR-HULL CM and **VeriSTAR-HULL** encompass the fatigue assessment carried out on selected structural details as per the requirements of Part B.

The requirements for the assignment of these notations are given in Pt F, Ch 1, Sec 1.

The additional class notations **VeriSTAR-HULL CM** and **VeriSTAR-HULL** may be completed by **FAT** when a fatigue assessment has been carried on selected structural details in accordance with Pt B, Ch 7, Sec 4 and Part D or Part E when relevant.

The notation **FAT** may be completed by **xx years**, with xx having values between 25 and 40, when evaluated design fatigue life is not less than xx years.

The additional class notations **VeriSTAR-HULL CM**, **VeriSTAR-HULL**, **VeriSTAR-HULL CM FAT**, and **VeriSTAR-HULL FAT** may be assigned to ships of less than 170 m in length, subject to special consideration by the Society.

Note 1: For vessels contracted before 1st July 2016 the notation **DFL xx years** may have been assigned in lieu of **FAT xx years**.

6.2.3 VeriSTAR-HULL SIS

The additional class notation **VeriSTAR-HULL SIS** may be assigned to ships in place of notations **VeriSTAR-HULL CM** and **VeriSTAR-HULL** when the structural condition is reassessed using survey data.

The requirements for the assignment and maintenance of this notation are given respectively in Pt F, Ch 1, Sec 1 and in Ch 5, Sec 2.

This notation is not applicable to ships assigned with the additional service feature **CSR**.

This notation may be completed by **FAT** or **FAT xx years** as detailed in [6.2.2].

Note 1: For vessels contracted before 1st July 2016 the notation **DFL xx years** may have been assigned in lieu of **FAT xx years**.

6.2.4 STAR-HULL

The additional class notation **STAR-HULL** is assigned to ships for which, in addition to the requirements for assignment of the additional class notation **VeriSTAR-HULL SIS**, an Inspection and Maintenance Plan for the hull is implemented by the Owner.

This notation is not applicable to ships assigned with the additional service feature **CSR**.

The requirements for the assignment and maintenance of this notation are given respectively in Pt F, Ch 1, Sec 2 and in Ch 5, Sec 2.

6.2.5 STAR-MACH

The additional class notation **STAR-MACH** may be assigned, after construction, to ships for which a risk analysis has been performed for ship propulsion, steering installations and associated auxiliary systems (machinery, electrical) in order to support and validate the Maintenance Plan in the operating context.

The requirements for the assignment of this notation are given in Pt F, Ch 1, Sec 3.

6.2.6 STAR-MACH SIS

The additional class notation **STAR-MACH SIS** is assigned to ships on which a Planned Maintenance Survey system for machinery (PMS) is implemented as per the requirements of Ch 2, Sec 2, [4.4] for which the Maintenance Plan of the

ship propulsion, steering installations and associated auxiliary systems (machinery, electrical) is re-approved periodically based on a risk analysis update.

The requirements for the assignment and maintenance of this notation are given respectively in Pt F, Ch 1, Sec 3 and in Ch 5, Sec 2.

6.2.7 STAR SIS

When ships are assigned the notations **STAR-HULL** and **STAR-MACH SIS**, the two separate notations are superseded by the cumulative additional class notation **STAR SIS**.

6.2.8 STAR-REGAS

The additional class notation **STAR-REGAS** may be assigned, after construction, to ships having both the service notation **liquefied gas carrier** and the additional service feature **REGAS** (with or without the additional service feature **STL-SPM**) and for which a risk analysis has been performed for the regasification installation and its associated systems, in order to support and validate the maintenance plan in the operating context.

The requirements for the assignment of this notation are given in Pt F, Ch 1, Sec 4.

6.2.9 STAR-CARGO

The additional class notation **STAR-CARGO** may be assigned, after construction, to ships liable to carry cargoes and for which a risk analysis has been performed for the cargo handling installation and its associated systems, in order to support and validate the maintenance plan in the operating context.

The requirements for the assignment of this notation are given in Pt F, Ch 1, Sec 5.

6.3 Availability of machinery (AVM)

6.3.1 General

The notations dealt with under this heading are relevant to systems and/or arrangements enabling the ship to carry on limited operations when single failure affects propulsion or auxiliary machinery or when an external event such as fire or flooding involving machinery spaces affects the availability of the machinery.

In compliance with [6.1.3], these notations are assigned a construction mark, as defined in Article [3].

The requirements for the assignment and maintenance of these notations are given respectively in Part F, Chapter 2 and in Ch 5, Sec 3.

6.3.2 Alternative propulsion system (AVM-APS)

The additional class notation **AVM-APS** is assigned to ships which are fitted with systems and/or arrangements enabling them to maintain operating conditions with some limitations in speed, range and comfort, in the case of single failure of items relative to the propulsion or power generating system.

The limitations in operation and the types of single failure covered by this notation are specified in Pt F, Ch 2, Sec 1, [1.2].

6.3.3 Duplicated propulsion system (AVM-DPS)

The additional class notation **AVM-DPS** is assigned to ships which are fitted with a duplicated propulsion system enabling them to maintain operating conditions with some limitations in power (but 50% of the main power is to be maintained), speed, range and comfort, in the case of single failure of items relative to the propulsion or power generating system.

The limitations in operation and the types of failure which are covered by this notation are specified in Pt F, Ch 2, Sec 2, [1.2].

The additional suffix **NS** may be added to the notation when the ship is intended for normal operation with one propulsion system out of service in accordance with the provisions of Pt F, Ch 2, Sec 2, [4].

Note 1: The loss of one compartment due to fire or flooding is not considered as a single failure case.

6.3.4 Independent propulsion system (AVM-IPS)

The additional class notation **AVM-IPS** is assigned to ships which are fitted with an independent propulsion system enabling them to maintain operating conditions with some limitations in power (but 50% of the main power is to be maintained), speed, range and comfort, in the case of single failure of items relative to the propulsion or power generating system.

The limitations in operation and the types of failure which are covered by this notation are specified in Pt F, Ch 2, Sec 3, [1.2].

The additional suffix **NS** may be added to the notation when the ship is intended for normal operation with one propulsion system out of service in accordance with the provisions of Pt F, Ch 2, Sec 3, [4].

Note 1: The loss of one compartment due to fire or flooding is considered as a single failure case.

6.3.5 Fire mitigation for main diesel-generator rooms (AVM-FIRE)

The additional class notation **AVM-FIRE** is assigned to ships which are fitted with an electrical production plant distributed over minimum two main diesel-generator rooms enabling to maintain sufficient operating functionality with respect to propulsion, safety, navigation and steering, and a minimum of 50% operability for defined habitability services in case of loss of one main diesel-generator room due to fire.

The additional class notation **AVM-FIRE** is assigned alone or in addition to the additional class notation **AVM-APS** or **AVM-DPS**.

6.4 Automated machinery systems (AUT)

6.4.1 General

The notations dealt with under this heading are relevant to automated machinery systems installed on board ships.

In compliance with [6.1.3], these notations are assigned a construction mark, as defined in Article [3].

The requirements for the assignment and maintenance of these notations are given respectively in Part F, Chapter 3 and in Ch 5, Sec 4.

6.4.2 Unattended machinery space (AUT-UMS)

The additional class notation **AUT-UMS** is assigned to ships which are fitted with automated installations enabling machinery spaces to remain periodically unattended in all sailing conditions including manoeuvring.

6.4.3 Centralised control station (AUT-CCS)

The additional class notation **AUT-CCS** is assigned to ships which are fitted with machinery installations operated and monitored from a centralised control station.

6.4.4 Automated operation in port (AUT-PORT)

The additional class notation **AUT-PORT** is assigned to ships which are fitted with automated installations enabling the ship's operation in port or at anchor without personnel specially assigned for the watch-keeping of the machinery in service.

6.4.5 Integrated machinery system (AUT-IMS)

The additional class notation **AUT-IMS** is assigned to ships which are fitted with automated installations enabling machinery spaces to remain periodically unattended in all sailing conditions including manoeuvring, and additionally provided with integrated systems enabling to handle control, safety and monitoring of machinery.

The notation **-HWIL** is added to the additional class notation **AUT-IMS** when the control system has been verified according to the requirements of NR632, Hardware-in-the-loop Testing.

6.5 Integrated ship systems (SYS)

6.5.1 General

The notations dealt with under this heading are relevant to operation of integrated systems regarding navigation, machinery, communication and specific cargo, as applicable.

In compliance with [6.1.3], these notations are assigned a construction mark, as defined in Article [3].

The requirements for the assignment and maintenance of these additional class notations are given, as applicable, in:

- NR633 for the notation **SYS-NEQ-OSV**
- Part F, Chapter 4 and Ch 5, Sec 5, respectively, for the other notations **SYS**.

6.5.2 Centralised navigation equipment (SYS-NEQ and SYS-NEQ-1)

The additional class notation **SYS-NEQ** is assigned to ships which are fitted with a centralised navigation control system so laid out and arranged that it enables normal navigation and manoeuvring operation of the ship by two persons in cooperation.

The additional class notation **SYS-NEQ-1** is assigned when, in addition to the above, the installation is so arranged that the navigation and manoeuvring of the ship can be operated under normal conditions by one person, for periodical one man watch. This notation includes specific requirements for prevention of accidents caused by the operator's unfitness.

6.5.3 Integrated bridge system (SYS-IBS and SYS-IBS-1)

The additional class notation **SYS-IBS** is assigned to ships fitted with an integrated bridge system which allows simplified and centralised bridge operation of the main functions of navigation, manoeuvring and communication, as well as monitoring from bridge of other functions related to passage execution, route control and monitoring and control and monitoring of machinery installation according to Part C, Chapter 3.

The notation **SYS-IBS** is assigned only to ships which are also assigned the additional class notation **SYS-NEQ**.

The additional class notation **SYS-IBS-1** is assigned to ships fitted with an integrated bridge system which allows simplified and centralised bridge operation of the main functions of navigation, manoeuvring and communication, as well as monitoring from bridge of other functions related to passage execution, route control and monitoring and control and monitoring of machinery installation according to Part C, Chapter 3 and Pt F, Ch 3, Sec 1 (**AUT-UMS** notation).

In addition, the following functions may be part of the notation **SYS-IBS-1**:

- external/internal communication system
- monitoring of specific cargo operations
- pollution monitoring
- monitoring of heating, ventilation and air conditioning for passenger ships.

The notation **SYS-IBS-1** is assigned only to ships which are also assigned the additional class notation **SYS-NEQ-1**.

The notation **-HWIL** is added to the additional class notations **SYS-IBS** and **SYS-IBS-1** when the control system has been verified according to the requirements of NR632, Hardware-in-the-loop Testing.

6.5.4 Safety and security of communication system (SYS-COM)

The additional class notation **SYS-COM** is assigned to ships which are fitted with communication means in order to exchange data between vessel and shore to enable remote monitoring, analysis and troubleshooting from shore, increase the reliability of the vessel and operation while using more automation, support and enhance condition/preventative maintenance.

Note 1: Ships assigned with **CYBER-SECURE** notation are generally not required to be assigned with **SYS-COM** notation. The requirements of Rule Note NR659 are then applicable.

6.5.5 Bridge design and instrumentation (SYS-NEQ-OSV)

The additional class notation **SYS-NEQ-OSV** may be assigned to ships fulfilling specific requirements for bridge design and instrumentation, and, in addition, provided with further means for safe operation in all the waters, including areas with harsh operational and environmental conditions such as the North Sea.

The aim of the additional class notation **SYS-NEQ-OSV** is to reduce the risk, in bridge operation, of failure causing collision, contact and grounding.

The requirements for the assignment of this notation are given in Rule Note NR633.

6.6 Monitoring equipment (MON)

6.6.1 General

The notations dealt with under this heading are relevant to hull and tailshaft monitoring equipment installed on board ships.

6.6.2 Hull stress monitoring (MON-HULL)

The additional class notation **MON-HULL** is assigned to ships which are fitted with equipment continuously monitoring ship's dynamic loads through measurements of motions in waves and stresses/deformations in the hull structure.

The requirements for the assignment and maintenance of this notation are given respectively in Pt F, Ch 5, Sec 1 and in Ch 5, Sec 6.

6.6.3 Tailshaft monitoring system (MON-SHAFT)

The additional class notation **MON-SHAFT** is assigned to ships fitted with oil or water lubricated systems for tailshaft bearings. The assignment of this notation allows the ship to be granted a reduced scope for complete tailshaft surveys, see Ch 2, Sec 2, [5.5.3] and Ch 5, Sec 6, [3].

The requirements for the assignment and maintenance of this notation are given respectively in Pt F, Ch 5, Sec 2 and in Ch 5, Sec 6.

6.6.4 Ice load monitoring system (MON-ICE)

The additional class notation **MON-ICE** is assigned to ships which are fitted with equipment to continuously monitor ice loads exerted on ship's hull by ice formations.

The notation **MON-ICE** is to be completed by one of the criteria **L(i)** and **G**, as follows:

- **MON-ICE L(i)** for ships equipped with a local ice load monitoring system, where **i** is a (list of) Roman numeral(s) from **I** to **VII**, depending on the design scenario
- **MON-ICE G** for ships intended to perform ramming and required to be equipped with a hull girder ice load monitoring system.

Note 1: The above letters and numerals denote the location (i.e. areas and regions) of the sensors and the interaction scenario, and the two notations are cumulative.

Examples: **MON-ICE L(I, III, VI)**, **MON-ICE G**
MON-ICE L(II), **MON-ICE G**

The requirements for the assignment and maintenance of these notations are given respectively in NR616 Ice Load Monitoring System (MON-ICE) and in Ch 5, Sec 6.

6.7 Comfort on board ships (COMF)

6.7.1 General

The notations dealt with under this heading are relevant to the assessment of comfort on board ships with regard to the noise and/or vibration.

The parameters which are taken into consideration for the evaluation of the comfort, such as the level of noise, the level of vibration, may be indicated in a memoranda.

COMF notations, as defined in [6.7.2] to [6.7.5], are to be considered as design notations.

The requirements for the assignment of these notations are given in Part F, Chapter 6.

It is the responsibility of the Owner to advise the Society of modifications, alterations or repairs, including major machinery item replacements, which may lead to a significant modification of the noise and vibration levels on board compared to initial survey. In such a case, a renewal survey may be carried out following a measurement programme agreed between the Owner and the Society.

For ships intended with in-service assessment, the notations **COMF** as defined in [6.7.2] to [6.7.5] are followed by notation **-SIS**. The requirements for the maintenance of these notations are given in Ch 5, Sec 10.

6.7.2 Comfort with regard to noise (COMF-NOISE)

The additional class notation **COMF-NOISE** is assigned to ships satisfying levels of noise defined in Part F, Chapter 6. The assessment of noise levels is carried out through measurements during harbour and sea trials.

The notation is completed by a grade **1, 2** or **3** which represents the comfort level achieved for the assignment of the notation. The lower grade (**1**) corresponds to the higher class of comfort.

Example:

COMF-NOISE 2

6.7.3 Comfort with regard to vibration (COMF-VIB)

The additional class notation **COMF-VIB** is assigned to ships satisfying levels of vibration defined in Part F, Chapter 6. The assessment of vibration is carried out through measurements during harbour and sea trials.

The notation is completed by a grade:

- **1, 2** or **3** for an evaluation based on overall frequency criteria, or
- **1PK, 2PK** or **3PK** for an evaluation based on single amplitude peak criteria.

The grade represents the comfort level achieved for the assignment of the notation. The lower grade (**1** or **1PK**) corresponds to the higher class of comfort.

Example:

COMF-VIB 1PK

6.7.4 High comfort level with regard to noise (COMF+)

The additional class notation **COMF+** is assigned only to ships having the service notation **yacht** or **charter yacht** satisfying levels of noise defined in Pt F, Ch 6, Sec 5.

Note 1: The additional class notation **COMF+** may also be applied to ships assigned with the service notation **Passenger ship** after special consideration.

The requirements for the assignment of this notation are given in NR500, Rules for the Classification and Certification of Yachts.

6.7.5 Comfort for passenger and crew areas

The additional class notations **COMF-NOISE-Pax**, **COMF-NOISE-Crew**, followed by grade **1, 2** or **3** and **COMF-VIB-Pax** and **COMF-VIB-Crew**, followed by grade **1, 2** or **3** or **1PK, 2PK** or **3PK** are assigned to ships satisfying levels of noise / vibration defined in Part F, Chapter 6, for passenger or crew area, as applicable.

Example:

COMF-VIB-Crew 3

6.8 Pollution prevention

6.8.1 General

The notations dealt with under this heading are assigned to ships fitted with equipment and arrangements enabling them to control and limit the emission of polluting substances in the sea and the air.

The requirements for the assignment and maintenance of these notations are given respectively in Part F, Chapter 9 and in Ch 5, Sec 7.

6.8.2 Pollution prevention (CLEANSHIP)

The additional class notation **CLEANSHIP** is assigned to ships so designed and equipped as to control and limit the emission of polluting substances in the sea and the air in accordance with the provisions of Pt F, Ch 9, Sec 1 and Pt F, Ch 9, Sec 2.

6.8.3 Pollution prevention (CLEANSHIP SUPER)

The additional class notation **CLEANSHIP SUPER** is assigned to ships so designed and equipped as to control and limit the emission of polluting substances in the sea and the air in accordance with the provisions of Pt F, Ch 9, Sec 1 and Pt F, Ch 9, Sec 2.

Note 1: At least 3 eligible notations are to be assigned among the following ones:

AWT-A, AWT-B, AWT-A/B, BWT, EGCS-SCRUBBER, GWT, HVSC, NDO-x days, NOX-x%, OWS-x ppm, SOX-x%

Example:

CLEANSHIP SUPER (AWT, NOX-80%, SOX-60%)

6.8.4 Advanced wastewater treatment (AWT)

The following additional class notations are assigned to ships fitted with Advanced Wastewater Treatment plant in accordance with the provisions of Pt F, Ch 9, Sec 1 and Pt F, Ch 9, Sec 3 as relevant:

- **AWT-A** for ships complying with Alaska specific requirements
- **AWT-B** for ships complying with the specific requirements of IMO Resolution MEPC.227(64) paragraph 4.2 applicable to ships operating in special areas
- **AWT-A/B** for ships complying with the 2 above mentioned specific requirements.

Note 1: ships complying only with general requirements of IMO Resolution MEPC.227(64) are not granted with any specific notation.

6.8.5 Ballast water exchange (BWE)

The additional class notation **BWE** is assigned to ships intended for ballast water exchange at sea and whose design is in compliance with the technical provisions of BWM Convention (2004), Regulation D-1 and in accordance with the provisions of Pt F, Ch 9, Sec 1 and Pt F, Ch 9, Sec 3.

Note 1: the additional class notation **BWE** does not waive the ship from being in compliance with any statutory or local requirement applicable to her.

6.8.6 Ballast water treatment (BWT)

The additional class notation **BWT** is assigned to ships fitted with a Ballast Water Treatment plant in accordance with the provisions of Pt F, Ch 9, Sec 1 and Pt F, Ch 9, Sec 3.

6.8.7 Grey water treatment (GWT)

The additional class notation **GWT** is assigned to ships fitted with a treatment installation for grey waters in accordance with the provisions of Pt F, Ch 9, Sec 1 and Pt F, Ch 9, Sec 3.

6.8.8 No discharge operation (NDO-x days)

The additional class notation **NDO-x days** is assigned to ships designed for no discharge operation during x days, in accordance with the provisions of Pt F, Ch 9, Sec 1 and Pt F, Ch 9, Sec 3.

Note 1: **x days** is the number of consecutive days the ship is able to operate with the full complement of on-board people, including crew and passengers, without the need for discharging any substances into the sea. This number cannot be less than one day (24 hours).

6.8.9 NOx emissions control (NOX-x%)

The additional class notation **NOX-x%** is assigned to ships for which the average NOx emissions of engines are not to exceed x% of IMO Tier II limit in accordance with the provisions of Pt F, Ch 9, Sec 1 and Pt F, Ch 9, Sec 3.

6.8.10 High-performance oily water separator (OWS-x ppm)

The additional class notation **OWS-x ppm** is assigned to ships fitted with an oily water separator producing effluents having a hydrocarbon content not exceeding x ppm (parts per million) in accordance with the provisions of Pt F, Ch 9, Sec 1 and Pt F, Ch 9, Sec 3.

6.8.11 SOx emissions control (SOX-x%)

The additional class notation **SOX-x%** is assigned to ships for which the oil fuels used within and outside SECAs have a sulphur content not exceeding x% of the relevant IMO limit in accordance with the provisions of Pt F, Ch 9, Sec 1 and Pt F, Ch 9, Sec 3.

Note 1: As an alternative, equivalent arrangements (e.g. exhaust gas cleaning systems) may be accepted.

6.8.12 Exhaust gas cleaning system-SCRUBBER (EGCS-SCRUBBER)

The additional class notation **EGCS-SCRUBBER** is assigned to ships fitted with an Exhaust Gas Cleaning System using Scrubber(s) installed in accordance with the provisions of Pt F, Ch 9, Sec 1 and Pt F, Ch 9, Sec 3.

6.8.13 Ship energy efficiency management plan (SEEMP)

The additional class notation **SEEMP** is assigned upon satisfactory completion of the two following steps:

- preparation of the SEEMP by the Owner or Ship Manager
- review of the SEEMP by the Society.

The additional class notation **SEEMP** covers the issue of a specific structured SEEMP, in the aim of giving to the company an Energy Management method as per structure from ISO 50001.

The requirements for the assignment of this notation are given in NR586 Ship Energy Efficiency Management Plan.

6.8.14 SCRUBBER READY

The additional class notation **SCRUBBER READY** is assigned to ships on which an exhaust gas cleaning system is planned to be installed in the future. This additional class notations may be granted to a new ship or a ship in service during overhaul period. The requirements for the assignment of this notation are given in Pt F, Ch 11, Sec 24.

6.8.15 Ultra-low emission vessel (ULEV)

The additional class notation **ULEV** may be assigned to sea-going ships. The additional class notation **ULEV** may not be assigned to vessels dedicated to operations on inland waterways (including estuaries, rivers, estuary and lakes) falling into the scope of EU Regulation 2016/128.

The additional class notation **ULEV** refers to the capacity of the internal combustion engines installed on a ship to emit gaseous pollutants and particular pollutants at a very low level at the time of assignment of the notation.

When granting the additional class notation **ULEV**, a memorandum is to be endorsed in order to record the list of engines covered, the fuel(s) with which they have been tested and their ULEV mode if any.

The requirements for the assignment and the maintenance of this notation are given respectively in Pt F, Ch 11, Sec 26 and in Ch 5, Sec 7.

6.8.16 Continuous emission monitoring system (CEMS)

The additional class notations **CLEANSHIP** and **CLEANSHIP SUPER ()** may be completed by the notation **CEMS** when the ship is fitted with a measurement, monitoring, recording and transmission equipment of air emissions in compliance with the requirements laid down in Pt F, Ch 9, Sec 3.

The requirements for the maintenance of this notation are given in Ch 5, Sec 7.

6.9 Refrigerating installations

6.9.1 General

The notations dealt with under this heading are relevant to refrigerating installations fitted on board ships, including machinery and storing equipment or arrangements.

In compliance with [6.1.3], these notations are assigned a construction mark, as defined in Article [3].

The requirements for the assignment and maintenance of these notations are given respectively in Part F, Chapter 7 and in Ch 5, Sec 8.

6.9.2 Refrigerating installations for cargo (REF-CARGO)

The additional class notation **REF-CARGO** is assigned to ships fitted with refrigerating plants and holds intended to carry cargoes, with the condition that the number and the power of the refrigerating units are such that the specified temperatures can be maintained with one unit on standby.

The notation **-AIRCONT** is added when the refrigerating plant is equipped with controlled atmosphere installations.

6.9.3 Refrigerating installations for insulated containers (REF-CONT)

The additional class notation **REF-CONT** is assigned to ships fitted with refrigerating plants for insulated containers carried in holds of container ships.

The additional class notation **REF-CONT** is followed by a suffix:

- **(A)** where the containers are cooled by a permanently installed refrigerating plant designed to supply refrigerated air to insulated containers carried in holds of container ships, with the condition that the number and the power of the refrigerating units are such that the specified temperatures can be maintained with one unit on standby
- **(E)** where the ship is intended only to supply electrical power to self-refrigerated containers.

The notation **-AIRCONT** is added to the additional class notation **REF-CONT (A)** when the refrigerating plant is equipped with controlled atmosphere installations.

6.9.4 Refrigerating installations for domestic supplies (REF-STORE)

The additional class notation **REF-STORE** is assigned to ships fitted with refrigerating plants and spaces exclusively intended for the preservation of ship's domestic supplies.

6.9.5 The additional class notations **REF-CARGO**, **REF-CONT** and **REF-STORE** may also be completed by the following notations:

- a) **-PRECOOLING** when the refrigerating plants are designed to cool down a complete cargo of fruit and/or vegetables to the required temperature of transportation
- b) **-QUICKFREEZE** for the refrigerating plants of fishing vessels and fish factory ships where the design and equipment of such plants have been recognised suitable to permit quick-freezing of fish in specified conditions.

6.10 Navigation in ice

6.10.1 The notations dealt with under [6.10.2] are relevant to ships strengthened for navigation in ice in accordance with the "Finnish-Swedish Ice Class Rules 1985 as amended".

The requirements for the assignment and maintenance of these notations are given respectively in Part F, Chapter 8 and in Ch 5, Sec 9.

These requirements reproduce the provisions of the Finnish-Swedish Ice Class Rules cited above.

Note 1: These National requirements are applicable for ships trading in the Finnish/Swedish waters and other relevant areas of the Baltic sea during the ice period.

6.10.2 The following additional class notations are assigned:

- **ICE CLASS IA SUPER** for ships with such structure, engine output and other properties that they are normally capable of navigating in difficult ice conditions without the assistance of icebreakers
- **ICE CLASS IA** for ships with such structure, engine output and other properties that they are capable of navigating in difficult ice conditions, with the assistance of icebreakers when necessary
- **ICE CLASS IB** for ships with such structure, engine output and other properties that they are capable of navigating in moderate ice conditions, with the assistance of icebreakers when necessary
- **ICE CLASS IC** for ships with such structure, engine output and other properties that they are capable of navigating in light ice conditions, with the assistance of icebreakers when necessary.

6.10.3 The additional class notations **ICE CLASS ID**, **YOUNG ICE 1** and **YOUNG ICE 2** are assigned to ships whose reinforcements for navigation in ice are different from those required for the assignment of the notations defined in [6.10.2] but who comply with the specific requirements detailed in Part F, Chapter 8.

Note 1: No minimum engine output is required for these notations.

6.10.4 The additional class notation **ICE** is assigned to ships whose reinforcements for navigation in ice are similar but not equivalent to those required for the assignment of the notations defined in [6.10.2] and [6.10.3], when this has been specially considered by the Society.

6.11 Navigation in polar waters

6.11.1 The notations dealt with under [6.11.2] are relevant to ships intended for navigation in ice-infested polar waters, except icebreakers.

The requirements for the assignment of these notations are given in Rule Note NR527 Rules for the Classification of **POLAR CLASS** and **ICEBREAKER** Ships.

Ships complying with the requirements of Rule Note NR527 and assigned with one of the additional class notations **POLAR CLASS** are also to comply with the requirements for the assignment of the additional class notation defined in [6.14.12]: **COLD (H t_{DH}, E t_{DE})**.

Note 1: Icebreaker refers to any ship having an operational profile that includes escort or ice management functions, having powering and dimensions that allow it to undertake independent operations in ice covered waters.

Note 2: Ships with the additional class notation **POLAR CLASS 6** or **POLAR CLASS 7** and not intended to operate in low air temperature may be exempted of the additional class notation **COLD (H t_{DH}, E t_{DE})**.

6.11.2 The following additional class notations are assigned:

- **POLAR CLASS 1** for year-round operations in all polar waters
- **POLAR CLASS 2** for year-round operations in moderate multi-year ice conditions
- **POLAR CLASS 3** for year-round operations in second-year ice which may include multi-year ice conditions
- **POLAR CLASS 4** for year-round operations in thick first-year ice which may include old ice inclusions
- **POLAR CLASS 5** for year-round operations in medium first-year ice which may include old ice inclusions
- **POLAR CLASS 6** for summer/autumn operations in medium first-year ice which may include old ice inclusions
- **POLAR CLASS 7** for summer/autumn operations in thin first-year ice which may include old ice inclusions.

6.12 Lifting appliances

6.12.1 Ships fitted with lifting appliances meeting the requirements of NR526 Rules for the Certification Lifting Appliances onboard Ships and Offshore Units may be assigned the following additional class notations:

- a) **ALP** for appliances intended to be used at harbour, for loading or unloading cargoes, equipments, spare parts or consumable
- b) **ALM** for appliances intended to be used in offshore conditions for various lifting operations exclusive of the appliances mentioned in item a).

Note 1: Ships fitted with lifting appliances used in harbour or in similar conditions for lifting operations other than ships loading or unloading may be assigned the additional service notation **ALP**.

6.12.2 The additional class notations (**ALP**) or (**ALM**) may be assigned by the Society in lieu of the notations **ALP** or **ALM** respectively, when the corresponding lifting appliances meet the requirements of specific National Regulations under the conditions defined in NR526.

6.12.3 The additional class notation **ALM** may be completed by:

- **-EN**, when lifting appliances are in compliance with additional specific safety requirements as defined in NR526
- **-SUBSEA**, when lifting appliances are intended to be used for lifting of subsea equipment in compliance with some specific requirements.

6.12.4 The additional class notations **ALP**, **ALM**, **ALM-EN** and **ALM-SUBSEA** may be completed by **-MR** when, in addition, lifting appliances are intended to be used for lifting of personnel.

6.12.5 The additional class notations **ALP**, **ALM**, (**ALP**), (**ALM**), **ALM-EN** or **ALM-SUBSEA** are optional. However, the Society may require the compliance of lifting appliances with the assigning conditions of one of the above mentioned additional class notations for the classification of ships, when one or several lifting appliances are of a primary importance for their operation, or when such appliances sig-

nificantly influence their structure. As a rule, such is the case for the shear leg pontoons, crane pontoons, crane vessels and when the lifting appliances concerned have special high capacities, for example in case of ships specially equipped for handling very heavy loads.

6.12.6 In compliance with [6.1.3], these notations are assigned a construction mark as defined in [3].

6.12.7 The requirements for assignment and maintenance of these notations are given in NR526.

6.13 Emergency response service (ERS)

6.13.1 General

The notations dealt with under this Article are related to the provision of technical assistance in case of a maritime accident at sea by providing information on their remaining strength and stability in the resulting damaged condition.

The requirements for the assignment and maintenance of these notations are given in NR556 (Emergency Response Service).

6.13.2 ERS-S (Strength), ERS-H (Hydrodynamic), ERS-M (Mooring), [ERS-S] (Strength-partial), [ERS-H] (Hydrodynamic-partial) and [ERS-M] (Mooring-partial) services

ERS-S corresponds to damage longitudinal strength and damage stability analyses. It aims at providing information on the remaining hull strength and stability after the accident.

ERS-H aims at providing limits of navigation, based on direct calculations of vertical wave bending moment and vertical wave shear force for the accidental site sea-states, instead of empirical rule formulae. It is only applied in complement to **ERS-S**. It aims at providing maximum environmental conditions (Hs), heading restriction, or speed limit. These limits of navigation are given for hull girder strength only.

ERS-M corresponds to damaged mooring analyses for permanently moored units. It aims at providing information on the remaining capacities of the mooring system after the failure of one or several mooring lines and the potential failure of an additional mooring line.

[**ERS-S**], [**ERS-H**] and [**ERS-M**] are assigned to ships until the respective ERS service becomes fully effective. The Society will provide service in case of damage as far as possible depending on the available information.

Note 1: The notations [**ERS-S**], [**ERS-H**] and [**ERS-M**] are replaced respectively by **ERS-S**, **ERS-H** and **ERS-M** when all necessary information has been made available to the Society allowing the service to become fully effective.

6.14 Other additional class notations

6.14.1 Strengthened bottom

The additional class notation **STRENGTHBOTTOM** may be assigned to ships built with specially strengthened bottom structures so as to be able to be loaded and/or unloaded when properly stranded.

The requirements for the assignment and maintenance of this notation are given respectively in Pt F, Ch 11, Sec 1 and in Ch 5, Sec 10.

6.14.2 Loading by grabs

- a) Loading by grabs for bulk carriers subject to NR522 Common Structural Rules for Bulk Carriers or to NR606 Common Structural Rules for Bulk Carriers and Oil Tankers.

The additional class notation **GRAB [X]** is assigned to ships with holds designed for loading/unloading by grabs having a maximum specific weight up to [X] tons.

The requirements for the assignment of this notation are given in NR522 Common Structural Rules for Bulk Carriers or in NR606 Common Structural Rules for Bulk Carriers and Oil Tankers.

The requirements for the maintenance of this notation are given in Ch 5, Sec 10.

Note 1: It is reminded that for bulk carriers assigned with the additional service feature **CSR**, and one of the additional service features **BC-A** or **BC-B**, **GRAB [X]** is assigned as a mandatory additional service feature.

For bulk carriers assigned with the additional service feature **CSR** others than above, **GRAB [X]** may be assigned on a voluntary basis as an additional class notation.

It is to be noted that this additional class notation does not negate the use of heavier grabs, but the owner and operators are to be made aware of the increased risk of local damage and possible early renewal of inner bottom plating if heavier grabs are used regularly or occasionally to discharge cargo.

- b) Loading by grabs for ships other than those subject to NR522 Common Structural Rules for Bulk Carriers or to NR606 Common Structural Rules for Bulk Carriers and Oil Tankers.

The additional class notation **GRABLOADING** may be assigned to ships with hold tank tops specially reinforced for loading/unloading cargoes by means of grabs or buckets.

The requirements for the assignment and maintenance of this notation are given respectively in Pt F, Ch 11, Sec 2 and in Ch 5, Sec 10.

Note 2: This additional class notation may only be assigned to ships with the service notation **general cargo ship** (intended to carry dry bulk cargoes), **ore carrier**, **combination carrier/OBO**, **combination carrier/OOC** or **bulk carrier** not assigned with the additional service feature **CSR**.

However, this does not preclude ships not assigned with this notation from being loaded/unloaded with grabs.

6.14.3 In-water survey

The additional class notation **INWATERSURVEY** may be assigned to ships provided with suitable arrangements to facilitate the in-water surveys as provided in Ch 2, Sec 2, [5.4.5].

The requirements for the assignment of this notation are given in Pt F, Ch 11, Sec 3.

6.14.4 Single point mooring

The additional class notation **SPM** (Single Point Mooring) may be assigned to ships fitted with a specific mooring installation.

The requirements for the assignment and maintenance of this notation are given respectively in Pt F, Ch 11, Sec 4 and in Ch 5, Sec 10.

These requirements reproduce the provisions of "Recommendations for Equipment Employed in the Bow Mooring of Conventional Tankers at Single Point Moorings" (4th edition - May 2007), issued by OCIMF (Oil Companies International Marine Forum).

6.14.5 Container lashing equipment

The additional class notation **LASHING** may be assigned to ships initially fitted with mobile container lashing equipment which has been documented, tested and checked.

The additional class notation **LASHING-WW** may be assigned in lieu of the notation **LASHING** to any ship, except if the ship is intended to be operated solely in North-Atlantic or North-Pacific area.

The additional class notation **LASHING (specific area)** may be assigned in lieu of the notation **LASHING** to ships navigating only in specific restricted areas such as Baltic Sea, Mediterranean Sea or South China Sea.

These notations are assigned only to ships having the service notation **container ship** or the additional service feature **equipped for carriage of containers**.

This equipment, however, will not be verified any longer at the periodical class surveys to which the ship is submitted.

The requirements for the assignment of these notations are given in Pt F, Ch 11, Sec 5.

6.14.6 Dynamic positioning

The additional class notation **DYNAPOS** may be assigned to ships equipped with a dynamic positioning system.

In compliance with [6.1.3], this notation is assigned a construction mark, as defined in Article [3].

The scope of the additional class notation **DYNAPOS**, including the additional notations for the description of capability of the installation (**SAM**, **AM**, **AT**, **AM/AT**), and the requirements for the assignment of this notation are given in Pt F, Ch 11, Sec 6.

The requirements for the maintenance of this notation are given in Ch 5, Sec 10.

The additional class notations **DYNAPOS AM/AT R** or **DYNAPOS AM/AT RS** may be completed by **-EI** for ships fitted with enhanced dynamic positioning control system and complying with the requirements of Pt F, Ch 11, Sec 6. This notation allows improving the reliability, availability and operability of a DP vessel.

The additional class notations **DYNAPOS** may be completed, by the notations **-HWIL** and/or **-DDPS** as follows:

- a) The notation **-HWIL** is added to the additional class notation **DYNAPOS** when the DP control system and the power management system have been verified according to the requirements of NR632, Hardware-in-the-loop Testing.
- b) The notation **-DDPS** is added to the additional class notation **DYNAPOS** when the ship is fitted with a system which enables the vessel to undertake digital surveys in compliance with Pt F, Ch 11, Sec 6, [11].

The notation **-DDPS** allows the ship's crew to conduct tests, proving the ability of a DP vessel to keep position after single failures associated with the assigned equipment class and to validate the FMEA and operation manual, as a part of annual survey as laid down in Ch 5, Sec 10, [5.1.2] and only for this part, according to their own schedule within the window of the Annual Survey, with the results witnessed by the Society digitally.

Any test from the approved FMEA test programme not completed by ship's crew at the time of Surveyor's attendance for annual survey has to be carried out before completion of the survey.

A confirmatory survey, to be carried out by a Surveyor of the Society, is to be requested, when the ship is within the window for annual survey of its classed DP system.

The Surveyor carries out the annual survey as laid down in Ch 5, Sec 10, [5.1] and satisfies himself with the validation of the FMEA and operations manual, based on the reports/records provided by the ship's crew. If doubts arise, the Surveyor extend the tests as deemed necessary.

6.14.7 Vapour control system

The additional class notation **VCS** (Vapour Control System) may be assigned to ships equipped with cargo vapour control systems. The notation **-TRANSFER** is added to the notation where, in addition, the ship is fitted with specific arrangements for transferring cargo vapours to another ship.

This notation is assigned only to ships having the service notation **oil tanker, combination carrier/OBO ESP, combination carrier/OOC ESP, liquefied gas carrier, chemical tanker or FLS tanker**. For the service notation **liquefied gas carrier**, the additional class notation **VCS** may be assigned only to gas carriers designed for various cargoes, especially those ones which are also covered by IBC code. This notation can not be assigned to LNG carrier or LNG Bunkering Ship.

The requirements for the assignment and maintenance of this notation are given respectively in Pt F, Ch 11, Sec 7 and in Ch 5, Sec 10.

6.14.8 Cofferdam ventilation

The additional class notation **COVENT** may be assigned to ships having cofferdams in the cargo area which can be used as ballast tanks and which may be ventilated through a fixed ventilation system.

This notation is assigned only to ships having the service notation **bulk carrier, ore carrier, oil tanker, combination carrier/OBO, combination carrier/OOC, liquefied gas carrier, chemical tanker or FLS tanker**.

The requirements for the assignment and maintenance of this notation are given respectively in Pt F, Ch 11, Sec 8 and in Ch 5, Sec 10.

6.14.9 Centralised cargo control

The additional class notation **CARGOCONTROL** may be assigned to ships (carrying liquid cargo in bulk) equipped with a centralised system for handling cargo and ballast liquids.

In principle, this notation is assigned only to ships having the service notation **oil tanker, combination carrier/OBO, combination carrier/OOC, chemical tanker or FLS tanker**.

The requirements for the assignment and maintenance of this notation are given respectively in Pt F, Ch 11, Sec 9 and in Ch 5, Sec 10.

6.14.10 Ship manoeuvrability

The additional class notation **MANOVR** may be assigned to ships complying with the requirements related to manoeuvring capability defined in Pt F, Ch 11, Sec 10.

Note 1: According to Resolution MSC.137(76), these provisions are to be applied to ships of all rudder and propulsion types, of 100 m in length and over, and to chemical tankers and gas carriers regardless of the length, which were constructed on or after 1 January 2004.

6.14.11 Ship subdivision and damage stability

The additional class notation **SDS** may be assigned to ships for which a damage buoyancy, subdivision and stability file has been examined and found to satisfy the requirements given in Pt B, Ch 3, Sec 3 or those required for granting the service notation, when applicable.

An attestation of compliance may be issued to the Interested Party, specifying the rules and criteria considered for the examination of the file.

Note 1: As a rule, class assigned to a ship does not cover requirements applicable to the assignment of the notation **SDS**.

6.14.12 Ships operating in cold weather conditions

The additional class notations **COLD DI** and **COLD (H t_{DH}, E t_{DE})** are assigned to ships intended to operate in cold climate environments as specified in Note 1.

Note 1:

- sea water temperature: not below -2°C
- wind speed: not higher than 30 knots.

The additional class notation **COLD DI** is assigned to ships operating in cold climate environments for shorter periods, not necessarily including ice covered waters and fitted with systems and equipment for de-icing.

The additional class notation **COLD (H t_{DH}, E t_{DE})** is assigned to ships operating in cold weather conditions and which are built and fitted with systems and equipment for de-icing where t_{DH} and t_{DE} are defined, respectively for hull and equipment exposed to low air temperature, by:

- t_{DH} : Lowest mean daily average air temperature in the area of operation, in °C, to be considered for the hull exposed to low air temperature, provided by the ship designer
- t_{DE} : Lowest design external air temperature in the area of operation, in °C, to be considered for the equipment exposed to low air temperature, provided by the ship designer. This temperature can be set to about 20°C below the lowest mean daily average air temperature if information for the relevant trade area is not available.

The requirements for the assignment and maintenance of these notations are given respectively in Pt F, Ch 11, Sec 11 and in Ch 5, Sec 10.

6.14.13 Liquid cold cargoes (COLD CARGO)

The additional class notation **COLD CARGO** is assigned to ships having one of the service notation **oil tanker**, **product tanker** or **chemical tanker** intended to be loaded with liquid cargoes:

- having a cargo temperature below -10°C , in particular when loading is from cold storage tanks (winter conditions), and
- not needing to be heated in normal operating conditions.

The requirements for the assignment and maintenance of this notation are given respectively in Pt F, Ch 11, Sec 11 and in Ch 5, Sec 10.

6.14.14 Green passport for ship recycling

The additional class notation **GREEN PASSPORT** or **GREEN PASSPORT EU** may be assigned to ships for which requirements intended to facilitate ship recycling have been applied, encompassing the identification, quantification and localization of materials which may cause harm to the environment and people when the fittings or equipment containing such materials are removed, or when the ship is recycled, as detailed hereafter.

GREEN PASSPORT may be assigned to ships for which such requirements have been applied in accordance with:

- the Hong Kong International Convention for the Safe and Environmentally Sound Recycling of Ships, 2009, and
- the European Regulation Reg (EU) N°1257/2013 on Ship Recycling, as amended, as applicable to ships flying the Flag of a non-EU member State.

GREEN PASSPORT EU may be assigned to ships for which such requirements have been applied in accordance with:

- the Hong Kong International Convention for the Safe and Environmentally Sound Recycling of Ships, 2009, and
- the European Regulation Reg (EU) N°1257/2013 on Ship Recycling as applicable to ships flying the Flag of a EU member State.

The requirements for the assignment and maintenance of this notation are given in NR528 Green Passport.

6.14.15 Efficient washing of cargo tanks

The additional class notation **EWCT** may be assigned to ships fitted with washing arrangements complying with the requirements given in Pt F, Ch 11, Sec 12.

This notation may only be assigned to ships having the service notation **oil tanker**, **FLS tanker**, or **chemical tanker**.

6.14.16 Protected FO tank

The additional class notation **PROTECTED FO TANK** may be assigned to ships with an aggregate oil fuel capacity of less than 600 m^3 , fitted with oil fuel tanks complying with the requirements given in Pt F, Ch 11, Sec 13.

6.14.17 Sealed liquefied natural gas carriers

The additional class notation **IATP** (increased admissible cargo tank pressure) may be assigned to ships intended to carry methane (LNG) whose maximum cargo tank design

pressure does not exceed 70 kPa and that are designed and built so as to allow the pressure in the tanks to increase above 25 kPa.

The additional class notation **IATP** is to be complemented, between brackets, by one of the following notations:

- **dual setting**, when a dual setting of the cargo tanks pressure relief valves is installed, or
- **boil-off**, when a boil-off handling system whose available capacity can be lower than 100% of the nominal boil-off rate of the ship during the periods referred to in Pt F, Ch 11, Sec 14, [4.3.2] is installed,
- **dual setting and boil-off**, when both systems are installed.

This notation may only be assigned to ships having the service notation **liquefied gas carrier** or **LNG bunkering ship**.

The requirements for the assignment of this notation are given in Pt F, Ch 11, Sec 14.

Note 1: In case of dual setting of the cargo tanks pressure relief valves, the operational conditions and limitations for both setting pressures are to be specified in a memoranda.

6.14.18 Enhanced fire protection (EFP-AMC)

The additional class notation **EFP-A** or **EFP-M** or **EFP-C** or **EFP-AMC** may be assigned to ships fitted with enhanced fire safety protection in, respectively, accommodation spaces or machinery spaces or cargo areas or all these spaces and areas.

The notations **EFP-A**, **EFP-C** and **EFP-AMC** may only be assigned to ships having one of the service notations listed in [4.2] (Cargo ships), or [4.3] (Bulk, ore and combination carriers), or [4.4] (Ships carrying liquid cargo in bulk). The notation **EFP-M** may be assigned to ships having one of the service notations listed in [4.2] (Cargo ships), or [4.3] (Bulk, ore and combination carriers), or [4.4] (Ships carrying liquid cargo in bulk), or [4.5] (Ships carrying passengers).

The requirements for the assignment of these notations are given respectively in Pt F, Ch 11, Sec 15.

The requirements for the maintenance of the notations **EFP-M** and **EFP-AMC** are given in Ch 5, Sec 10, [24].

6.14.19 Fast oil recovery system (FORS)

The additional class notation **FORS** may be assigned to ships with oil fuel tanks and cargo tanks, as applicable, fitted with two (or more) connectors allowing the recovery of the tank contents as follows:

- by injecting sea water through one connector, the tank contents being recovered through the other one, and
- by introducing a submersible pump in the tank through one of the connectors.

The requirements for the assignment of this notation are given in NR553 Fast Oil Recovery System.

The additional class notation **FORS** may be completed by the notation **-NS** when the connectors are intended to be used during the normal service of the ship and, for that purpose, comply with the additional requirements given in Article [3] of NR553 Fast Oil Recovery System.

For ships not assigned with the notation **-NS**, the connectors may be used only to facilitate the recovery of the tank contents when the ship is damaged or wrecked.

6.14.20 High-voltage shore connection systems (HVSC)

The additional class notation **HVSC** may be assigned to ships fitted with electrical and control engineering arrangements allowing operation of services by connection to an external high-voltage electrical power supply in port.

The requirements for the assignment of this notation are given in NR557 High-Voltage Shore Connection Systems.

6.14.21 SINGLEPASSLOADING

The additional class notation **SINGLEPASSLOADING** may be assigned to ships having the service notation **ore carrier** which are specially designed for single pass loading.

Note 1: This additional class notation may be completed by the design loading rate, in tons per hour, for example:

SINGLEPASSLOADING [xxxxx t/h]

The additional class notation **SINGLEPASSLOADING** only covers the loading sequences provided to the Society, as referred to in Pt F, Ch 11, Sec 16.

The requirements for the assignment of this notation are given in Pt F, Ch 11, Sec 16.

6.14.22 Helideck (HEL)

The additional class notation **HEL** may be assigned to ships complying with chapter II-2 of SOLAS and Civil Aviation Publication (CAP) 437 when they are fitted with helicopter facilities subject to design review and construction and installation survey by the Society.

The requirements for the assignment and maintenance of this notation are given respectively in Pt F, Ch 11, Sec 20 and in Ch 5, Sec 10.

6.14.23 Helicopter facilities for yachts

The additional class notation **HEL(Y)** may be assigned to ships assigned with service notation **yacht** or **charter yacht** fitted with helicopter facilities.

The requirements for the assignment of this notation are given in NR500, Rules for the Classification and Certification of Yachts.

6.14.24 Bow loading/unloading systems (BLUS) Stern loading/unloading systems (SLUS)

The additional class notations **BLUS** or **SLUS** may be assigned to ships having the service notation **oil tanker** and fitted with bow or stern loading/unloading systems.

The requirements for the assignment of these notations are given in Pt F, Ch 11, Sec 17.

6.14.25 Supply at sea (SAS)

The additional class notation **SAS** may be assigned to ships having the service notation **supply** and operated for underway ship-to-ship supply at sea (SAS) of liquid and solid supplies.

The requirements for the assignment of this notation are given in Pt F, Ch 11, Sec 18.

Note 1: Application to other service notations may be considered on a case-by-case basis.

6.14.26 HABITABILITY

The additional class notation **HABITABILITY** may be assigned to ships found to be in compliance with the criteria of the Maritime Labour Convention and with the provisions contained in the Guidance Note NI 577, Design and Construction of Crew Accommodation in respect of Title 3 of Maritime Labour Convention 2006.

The requirements for the maintenance of this notation are given in Ch 5, Sec 10.

Note 1: Ships assigned, before 1st January 2017, with the additional class notation **ACCOMMODATION** may keep this notation until the first renewal survey, time at which the former additional class notation is to be replaced by **HABITABILITY**.

6.14.27 Loading instrument (LI)

The additional class notations **LI-HG**, **LI-S1**, **LI-S2**, **LI-S3**, **LI-S4**, **LI-HG-S1**, **LI-HG-S2**, **LI-HG-S3**, **LI-HG-S4** and **LI-LASHING** may be assigned to ships equipped with a loading instrument.

The requirement for the assignment of these notations are given in Pt B, Ch 10, Sec 2.

Note 1: When the ship is equipped with a loading instrument performing:

- only hull girder calculations, the additional class notation **LI-HG** is assigned
- only intact stability calculations (when the ship is not required to meet damage stability requirements), the additional class notation **LI-S1** is assigned
- intact stability calculations and damage stability on a basis of a limit curve, the additional class notation **LI-S2** is assigned
- intact stability calculations and direct damage stability calculations based on pre-programmed damage cases, the additional class notation **LI-S3** is assigned
- damage stability calculations associated with an actual loading condition and actual flooding case, using direct application of user defined damage, for the purpose of providing operational information for safe return to port (SRtP), the additional class notation **LI-S4** is assigned
- lashing calculations, the additional class notation **LI-LASHING** is assigned.

When the loading instrument performs hull girder and stability calculations, one of the additional class notations **LI-HG-S1**, **LI-HG-S2** or **LI-HG-S3**, **LI-HG-S4** is assigned, as applicable.

6.14.28 The additional class notations **WhiSp1**, **WhiSp2** and **WhiSp3** may be assigned to ships complying with the requirements of NR583 Whipping and Springing Assessment.

6.14.29 Permanent means of access (ACCESS)

The additional class notation **ACCESS** may be assigned to ships constructed on or after 1 January 2006 and:

- assigned with service notations as specified in [4.4.2] for ships carrying oil cargo in bulk and of 500 gross tonnage and over, having integral tanks, or
- assigned with service notations as specified in [4.3] for bulk, ore and combination carrier of 20 000 gross tonnage and over.

The requirements for the assignment and maintenance of this notation are given respectively in Pt F, Ch 11, Sec 19 and in Ch 5, Sec 10.

6.14.30 Elastic shaft alignment (ESA)

The additional class notation **ESA** may be assigned to ships other than those covered by the scope of the relevant additional service feature as referred to in [4.15.1].

The requirements for the assignment of this additional class notation are given in Rule Note NR592 Elastic Shaft Alignment (ESA).

Note 1: The request and applicability for this notation are achieved respectively on a voluntary basis from the interested parties and on a case-by-case basis.

6.14.31 The additional class notation **STAB-WIND** may be assigned, to yacht having the service notation **yacht** or **charter yacht** satisfying the intact stability and weather criterion as defined in Rule Note NR500 Rules for the Classification and the Certification of Yachts.

Note 1: The attention of the Owner and the Shipyard is drawn to the fact that the flag Administration may impose an intact stability and weather criterion calculation.

6.14.32 Spectral fatigue analysis

The additional class notation **Spectral Fatigue ()** may be assigned when the fatigue check of structural details is performed through spectral fatigue techniques. The information between brackets is a short description of routes and areas considered for this spectral fatigue analysis and associated design fatigue life.

Example:

Spectral Fatigue (North Atlantic)

The Guidance Note NI 611, Guidelines for Fatigue Assessment of Steel Ships and Offshore units, is to be used.

Other methodology may be used, subject to approval by the Society.

6.14.33 Offshore handling systems (OHS)

The additional class notation **OHS** may be assigned to ships having offshore handling systems such as winches, strand jacks, chain jacks, sheaves and their foundations used for lifting/pulling of a load.

The requirements for the assignment and maintenance of this notation are given respectively in NR595 Classification of Offshore Handling Systems and in Ch 5, Sec 10.

Note 1: Specific procedures for non-permanent equipment are not applicable for ships.

6.14.34 Underwater radiated noise (URN)

The additional class notation **URN** may be assigned to self-propelled ships meeting the underwater radiated noise level limits complying with the requirements of NR614 Underwater Radiated Noise (URN).

According to the limits given in Rule Note NR614, the notation **URN** is to be completed as follows:

URN - controlled vessel

URN - advanced vessel

URN - specified vessel

The requirements for the assignment and maintenance of this notation are given in Rule Note NR614.

6.14.35 GAS-PREPARED

The additional class notation **GAS-PREPARED** applies to new ships that are designed with specific arrangements to accommodate future installation of an LNG fuel gas system.

The requirements for the assignment of this notation are given in Pt F, Ch 11, Sec 25.

The additional class notation **GAS-PREPARED** may be completed by the following additional notations:

- **S**, when specific arrangements are implemented for the ship structure
- **P**, when specific arrangements are implemented for piping
- **ME-DF**, when the main engine(s) is (are) of the dual fuel type
- **AE**, when the auxiliary engines are either of the dual fuel type, or designed for future conversion to dual-fuel operation
- **B**, when the oil-fired boilers are either of the dual fuel type, or designed for future conversion to dual fuel operation.

Examples:

- **GAS-PREPARED**
- **GAS-PREPARED (P)**
- **GAS-PREPARED (P, ME-DF)**
- **GAS-PREPARED (S, P, ME-DF)**

Note 1: When the ship is effectively converted to dual-fuel operation, the additional class notation **GAS-PREPARED** will be replaced by the additional service feature **LNGfuel dualfuel**, provided that all the applicable requirements given in [4.13.1] are complied with.

6.14.36 BATTERY SYSTEM

The additional class notation **BATTERY SYSTEM** may be assigned to ships when batteries are used for propulsion and/or electric power supply purpose during operation of the ship. This notation is mandatory when the ship is only relying on batteries for propulsion and/or electrical power supply for main sources.

The requirements for the assignment and maintenance of this notation are given respectively in Pt F, Ch 11, Sec 21 and Ch 5, Sec 10.

The requirements for the assignment of this notation are given in Pt F, Ch 11, Sec 21.

Note 1: when a ship is assigned the additional class notation **ELECTRIC HYBRID ()**, it is not necessary to assign the additional class notation **BATTERY SYSTEM**.

6.14.37 SAFE-LASHING

The additional class notation **SAFE-LASHING** may be assigned to ships having the service notation **container ship** or the additional service feature **equipped for carriage of containers** and the keel of which was laid, or which are at a similar stage of construction, on or after 1 January 2015.

The requirements for the assignment of this notation are given in IMO MSC.1/Circ.1352/Rev.1 "Amendments to the Code of Safe Practice for Cargo Stowage and Securing (CSS Code)", Annex 14 "Guidance on Providing Safe Working Conditions for Securing of Containers on Deck", paragraphs 4.3 "Cargo Safe Access Plan (CSAP)" and 6 "Design".

6.14.38 Offshore access system (OAS)

The additional class notation **OAS** may be assigned to ships fitted with an offshore access system, based on gangways and used for the transfer of persons from ships to offshore facilities or from ship to ship, certified in accordance with NI 629 Certification of Offshore Access Systems.

In compliance with [6.1.3], this notation is assigned a construction mark as defined in Article [3].

The requirements for the assignment and maintenance of this notation are given respectively in NI 629 Certification of Offshore Access Systems and in Ch 5, Sec 10.

6.14.39 Chemical, biological, radiological or nuclear hazards

The additional class notation **CBRN** may be assigned to civilian ships intended for operations in atmospheres contaminated by chemical, biological or nuclear hazardous material for rescue or damage control purposes and equipped with a citadel with a collective protection system that effectively protects people inside from contamination thanks to its dedicated ventilating system.

The additional class notation **CBRN-WASHDOWN** may be assigned to ships which, in addition to the above features, are provided with a wash-down system that will give increased protection during CBRN operations and will also allow immediate primary decontamination of the superstructures.

The requirements for the assignment and maintenance of these notations are given respectively in Part F, Chapter 10 and in Ch 5, Sec 10.

6.14.40 Electric hybrid

The additional class notation **ELECTRIC HYBRID ()** may be assigned to ships provided with an energy storage system (ESS) used to supply the electric propulsion and/or the main electrical power distribution system of the vessel.

The additional class notation **ELECTRIC HYBRID ()** is to be completed, between brackets, by at least one of the following notation:

- **PM**, when at least one of the following power management mode is available: load smoothing mode, peak shaving mode or enhanced dynamic mode
- **PB**, when power backup mode is available
- **ZE**, when zero emission mode is available.

The requirements for the assignment and maintenance of this notation are given in Pt F, Ch 11, Sec 22 and Ch 5, Sec 10.

Example:

ELECTRIC HYBRID (PM, ZE).

6.14.41 STABLIFT

The additional class notation **STABLIFT** may be assigned to ships engaged in lifting operations at sea and equipped for that purpose with one or several lifting equipment, having their residual stability during lifting operations checked and complying with the stability requirements specified in Pt E, Ch 8, Sec 3.

6.14.42 UNSHELTERED ANCHORING

The additional class notation **UNSHELTERED ANCHORING** is assigned to ships fitted with anchoring equipment in deep and unsheltered water complying with the requirements of Pt F, Ch 11, Sec 23, in addition to the requirements from Pt B, Ch 9, Sec 4, as applicable to equipment.

The requirements of this section apply to ships:

- with an equipment length L_E , as defined in Pt B, Ch 9, Sec 4, [1.2.2], greater than 135 m

and intended to anchor in deep and unsheltered water with:

- depth of water up to 120 m
- current speed up to 3 knots (1.54 m/s)
- wind speed up to 27 knots (14 m/s)
- waves with significant height up to 3 m.

The scope of chain cable, being the ratio between the length of chain paid out and water depth, is assumed to be to the maximum possible and not less than 3.

6.14.43 Cyber security

The additional class notations **CYBER MANAGED**, **CYBER SECURE**, **CYBER MANAGED PREPARED** and **CYBER SECURE PREPARED** may be assigned to ships whose systems and equipment comply with the requirements of NR659 Rules on Cyber Security for the Classification of Marine Units.

The additional class notation **CYBER MANAGED PREPARED** may be assigned to new buildings only and corresponds to compliance, at shipyard level, with a set of requirements dealing with system integration and the management of critical equipment and remote access:

- Granting of **CYBER MANAGED PREPARED** notation does not indicate an effective control of cyber security on-board ship during service life.
- When compliance with the dedicated requirement for management, crew training and change management are met, **CYBER MANAGED PREPARED** notation may be replaced by the additional class notation **CYBER MANAGED**.

The additional class notation **CYBER MANAGED** introduces on board operations dedicated to cyber security:

- The additional class notation **CYBER MANAGED** may be assigned to new buildings or ships in-service and corresponds to compliance with a set of requirements dealing with critical equipment management, crew training, remote access and change management.
- Granting of **CYBER MANAGED** notation implies that cyber security of the ship is controlled with manual procedures, requiring human actions, a strong human organization and a significant amount of procedures to achieve objective.

CYBER SECURE and **CYBER SECURE PREPARED** notations distinguish a way to control cyber security by means of automatic software. They requires dedicated technical equipment for security:

- The additional class notation **CYBER SECURE PREPARED** may be assigned to new buildings only and corresponds to compliance, at shipyard level, with a set of requirements dealing with equipment hardening and vessel secure by design

- When compliance with the dedicated requirement for cyber management are met, **CYBER SECURE PREPARED** notation may be replaced by the additional class notation **CYBER SECURE**
- The additional class notation **CYBER SECURE** may be assigned to new buildings or ships in-service already granted with **CYBER SECURE PREPARED** additional class notation and corresponds to compliance with a set of requirements dealing with cyber management, equipment hardening and vessel secure by design.

In compliance with [6.1.3], the additional class notation **CYBER SECURE** and **CYBER SECURE PREPARED** are assigned a construction mark, as defined in Article [3].

The requirements for the assignment of these notations are given in NR659, Rules on Cyber Security for the Classification of Marine Units.

The requirements for the maintenance of the notations **CYBER MANAGED** and **CYBER SECURE** are given in Ch 5, Sec 10.

6.14.44 Man overboard detection (MOB)

The additional class notation **MOB** may be assigned to self-propelled ships arranged with means capable of automatically detecting a person going overboard and instantaneously alert the ship's personnel.

This notation developed for passengers ships may be assigned to cargo ships at the discretion of Society.

The requirements for the assignment of this notation are given in Pt F, Ch 11, Sec 27.

6.14.45 Electric hybrid prepared

The additional class notation **ELECTRIC HYBRID PREPARED ()** may be assigned to new ships that are designed with specific arrangements intended to accommodate an Electric Hybrid installation in the future.

The additional class notation **ELECTRIC HYBRID PREPARED ()** is to be completed, between brackets, by at least one of the following notation:

- **PM**, when at least one of the following power management mode is available: load smoothing mode, peak shaving mode or enhanced dynamic mode
- **PB**, when power backup mode is available
- **ZE**, when zero emission mode is available.

The requirements for the assignment of this notation are given in Pt F, Ch 11, Sec 29.

Example:

ELECTRIC HYBRID PREPARED (PM, ZE).

6.14.46 Heading control

The additional class notations **HEADING CONTROL** may be assigned to ships arranged with redundant propulsion and steering systems in order to maintain their heading to the waves in adverse weather conditions and to avoid large transversal accelerations, taking into account the windage of the deck cargo if any.

The additional class notation **HEADING CONTROL** is complemented by:

- **-DS** for ships with duplicated propulsion systems able to maintain their heading to the waves in case of single failure on the propulsion or steering system
- **-IS** for ships with independent propulsion systems, which in addition to the requirements applicable to **-DS** notation, comply with additional requirements covering the event of fire or flooding casualty in machinery space.

The requirements for the assignment and the maintenance of these notations are given respectively in Pt F, Ch 11, Sec 28 and Ch 5, Sec 10, [20].

6.14.47 Parametric roll assessment (PaRoll)

The additional class notation **PaRoll1** or **PaRoll2** may be assigned to container ships, for which numerical simulations and operational guidance (polar plot) for evaluation of maximum dynamic roll angle (including parametric roll) in various loading conditions and sea states are developed in compliance with NR667.

- The additional class notation **PaRoll1** is granted to ships using only bilge keels as anti-rolling devices
- The additional class notation **PaRoll2** is granted to ships using anti-rolling devices such as anti-roll tank, stabilizer fins or any anti-rolling devices different from bilge keels.

The requirements for the assignment of this notation are given in NR667.

6.14.48 Enhanced cargo fire protection for container ships (ECFP)

The additional class notations **ECFP** may be assigned to ships fitted with equipment, systems and arrangements improving the ability to manage a container cargo fire, as follows:

- **ECFP-1**, when the ship is fitted with portable equipment and arrangements, as per Pt F, Ch 11, Sec 30, [2], that may be considered as retrofit for an existing ship
- **ECFP-2**, when, in addition to the requirements for the notation **ECFP-1**, the ship is fitted with equipment, systems and arrangements, as per Pt F, Ch 11, Sec 30, [3], which constitute an extensive set of mitigation measures which are deemed effective and available with standard technologies
- **ECFP-3**, when, in addition to the requirements for the above mentioned notations, the ship is fitted with equipment, systems and arrangements, as per Pt F, Ch 11, Sec 30, [4], which include measures that are deemed relevant using innovative technologies.

In general, the additional class notations **ECFP-1**, **ECFP-2** or **ECFP-3** may be granted to ships assigned with the service notation **container ship**. In general, the additional class notation **ECFP-1** may also be granted to ships having the additional service feature - **equipped for the carriage of containers**.

The additional class notations **ECFP-2** and **ECFP-3** are to be completed by the following notation (**Area 1, X_{1m} ; ... ; Area n, X_nm**), where:

- **Area n** indicates the cargo holds where the maximum flooding level X_n is allowed,
- **X_n**, corresponds to the maximum flooding level in area n, in meters, with respect to the bottom of the hold.

Examples:

ECFP-2(All cargo holds, 20m)

ECFP-3(Holds 1 to 4,16m; Holds 5 to 8, 20m; Holds 9 to 12, 15m)

The requirements for the assignment and the maintenance of these notations are given respectively in Pt F, Ch 11, Sec 30 and in Ch 5, Sec 10, [21].

6.14.49 Hybrid mechanical propulsion

The additional class notation **HYBRID MECHANICAL PROPULSION** may be assigned to ships provided with a propulsion plant which combines a diesel mechanical system and an electric system.

The requirements for the assignment and the maintenance of this notation are given respectively in Pt F, Ch 11, Sec 32, and in Ch 5, Sec 10, [23].

6.14.50 Biological risk control

The additional class notations **BIORISK MANAGED** and **BIORISK SECURED** may be assigned to ships where measures improving the ability to prevent and manage an infectious disease outbreak are implemented.

The additional class notation **BIORISK MANAGED** may be assigned when an outbreak management plan is established for the ship and implemented on board.

The additional class notation **BIORISK SECURED** may be assigned when, in addition to the above-mentioned outbreak management plan, systems and arrangements are provided on board in order to support the management of an infectious disease outbreak.

The requirements for the assignment and the maintenance of these additional class notations are given respectively in Pt F, Ch 11, Sec 31 and in Ch 5, Sec 10, [22].

6.14.51 Open hatch

The additional class notation **OPEN-HATCH** may be assigned to ships granted with the service notation **general cargo ship** intended to undertake sea voyage with one or several hatch covers not in place, as defined in Pt F, Ch 11, Sec 33.

The requirements for the assignment and maintenance of this additional class notation are given respectively in Pt F, Ch 11, Sec 33 and in Ch 4, Sec 7.

6.14.52 Units with a wind propulsion system (WPS)

Ships fitted with a wind propulsion system may be assigned the following additional class notations:

- **WPS1** for wind propulsion system including standing part
- **WPS2** for wind propulsion system including standing and running part.

In compliance with [6.1.3], these notations are assigned a construction mark as defined in [3].

The requirements for the assignment and the maintenance of these notations are given in NR206 Wind propulsion systems.

6.14.53 FSRU READY

The additional class notation **FSRU READY** may be assigned to ships having the service notation **liquefied gas carrier** that are designed and built with specific arrangements in view of accommodating future installation of a regasification system.

The additional class notation **FSRU READY** may be completed between brackets by one, or by a combination, of the following notations:

- **P**, when specific arrangements for piping and process systems are taken into account during the initial design of the ship in order to consider additional capacity for a future conversion
- **R**, when the regasification system, or main pieces of equipment, are defined at the time of assignment of the notation
- **I**, when the ship is designed and built in order to allow on-site in-water survey without dry-docking once converted into FSRU and subject to acceptance from Authorities.

The requirements for the assignment of this notation are given in Pt F, Ch 11, Sec 34.

6.14.54 AMMONIA PREPARED

Ships designed with specific arrangements to accommodate future installation of an ammonia fuel system may be granted the additional class notation **AMMONIA-PREPARED**.

The additional class notation **AMMONIA-PREPARED** may be completed between brackets with one or a combination of notations **S, T, H, P** and **B**:

- **S**, when specific arrangements are implemented for the ship structure at the original design stage with the aim of preventing the need for specific structural modifications at the conversion stage
- **T**, when at least one original LNG or LPG fuel storage tank can also be used with ammonia fuel, possibly with modifications of the operational conditions of the tank at the ship conversion stage
- **H**, when the original LNG or LPG fuel handling equipment (pumps, heat exchangers, compressors) can also be used with ammonia
- **P**, when the original LNG or LPG piping system can also be used with ammonia
- **B**, when the original LNG or LPG boil-off gas management method (other than pressure accumulation, i.e. combustion unit, boiler, scrubbing system or refrigerating system) can also be used with ammonia.

Examples:

AMMONIA-PREPARED

AMMONIA-PREPARED (T)

AMMONIA-PREPARED (S,T,H)

The requirements for the assignment of this additional class notation is given in Pt F, Ch 11, Sec 35.

6.14.55 Sustainable ships

The additional class notations **SUSTAINABLESHIP-1** or **SUSTAINABLESHIP-2** may be assigned to ships that are designed, built and equipped according to the requirements laid down in Pt F, Ch 11, Sec 36, focusing on the following sustainability aspects:

- prevention of sea and air pollution
- protection of the marine environment
- reduction of greenhouse gases emissions
- preparation for ship recycling
- enhancement of people well-being on board.

The requirements for the assignment of the additional class notations **SUSTAINABLESHIP-1** and **SUSTAINABLESHIP-2** are those corresponding to a combination of notations, their applicable associated requirements and any additional requirements, covering the sustainability aspects as defined in Pt F, Ch 11, Sec 36.

The maintenance of the additional class notations **SUSTAINABLESHIP-1** and **SUSTAINABLESHIP-2** are those respectively applicable to each required notations of the combination.

6.15 System fitted but not required by the rules

6.15.1 General

The notations dealt with in this sub-article are assigned only when a system is installed on board, although the ship does not meet the conditions under which the Rules request it to be fitted.

6.15.2 Inert gas

The additional class notation **IG** may be assigned to ships fitted with an inert gas system, as follows:

- Ships contracted for construction before 1 January 2016:
This notation is assigned only to ships having the service notation:
 - **oil tanker** or **FLS tanker**, and of less than 20000 tonnes deadweight, or
 - **chemical tanker** for which an inert gas system is not required in pursuance of July 2014 edition of the Rules, Pt D, Ch 8, Sec 9, [1.3.1].

The requirements for the assignment of the notation **IG** are given in July 2014 edition of the Rules:

- Pt D, Ch 7, Sec 6, [5.1.2], for oil tankers or FLS tankers, and
- Pt D, Ch 8, Sec 9, [2.5.3], for chemical tankers.
- Ships contracted for construction on or after 1 January 2016:
This notation is assigned only to ships having the service notation **oil tanker**, **FLS tanker** or **chemical tanker**, and of less than 8000 tonnes deadweight.
The requirements for the assignment of the notation **IG** are given in:
 - Pt D, Ch 7, Sec 6, [5.1.3], for oil tankers or FLS tankers, and
 - Pt D, Ch 8, Sec 9, [2.3], for chemical tankers.

- This notation may be assigned to ships having the service notation **supply**.

The requirements for the assignment of the **IG** notation are given in Pt D, Ch 8, Sec 9, [2.3].

The requirements for the maintenance of the notation **IG** are given respectively:

- for **oil tanker** or **FLS tanker**, in Ch 4, Sec 3, [3.4]
- for **chemical tanker** or **supply**, in Ch 4, Sec 4, [3.4].

6.15.3 Emergency towing arrangement

The additional class notation **ETA** may be assigned to ships fitted with an emergency towing arrangement.

In principle, this notation is assigned only to ships of less than 20000 tonnes deadweight having one of the service notations **oil tanker**, **combination carrier/OBO**, **combination carrier/OOC**, **liquefied gas carrier**, **LNG bunkering ship**, **chemical tanker** and **FLS tanker**.

The requirements for the assignment of this notation are given in Pt B, Ch 9, Sec 4, [3].

6.15.4 Coating performance standard CPS(WBT)

The additional class notation **CPS(WBT)** may be assigned to ships complying with the requirements of NR530 Coating Performance Standard.

Note 1: For bulk carriers and oil tankers assigned with the additional service feature **CSR** and contracted for construction on or after 8 December 2006, and for ships complying with IMO resolution MSC.215(82), as amended, and contracted for construction on or after 1 July 2008, reference is made to [4.3.2] and [4.4.2] for the mandatory assignment of the additional service feature **CPS(WBT)**.

6.15.5 Coating performance standard CPS(VSP)

The additional class notation **CPS(VSP)** may be assigned to bulk carriers and oil tankers complying with the requirements of NR530 Coating Performance Standard.

6.15.6 Coating performance standard CPS(COT)

The additional class notation **CPS(COT)** may be assigned to ships complying with the requirements of NR530 Coating Performance Standard.

Note 1: **CPS(COT)** applies to cargo oil tanks of crude oil tankers of 5 000 tonnes deadweight (DWT) and above.

7 Other notations

7.1

7.1.1 The Society may also define other notations by means of provisional requirements and guidelines, which may then be published in the form of tentative rules.

8 Diving systems

8.1 General

8.1.1 The service notations related to diving systems are listed in [8.1.2]. The requirements for the assignment of these service notations are given in NR610 Rules for the Classification of Diving Systems.

8.1.2 The following service notations are to be assigned to the diving systems, as relevant:

- **Diving system-integrated**, for the diving systems permanently installed on diving support units
- **Diving system-portable**, for the diving systems on portable modules and installed temporarily on diving support units
- **Hyperbaric reception facility**, when a decompression chamber is used to transfer the occupants of hyperbaric rescue units.

8.1.3 The service notations **Diving system-integrated** and **Diving system-portable** are to be completed by one of the following additional service features:

- **surface air**, for diving systems using only compressed air
- **surface mixed-gas**, for diving systems using mixed-gas
- **saturation**, for saturation diving systems
- **bounce**, for bounce systems using a closed bell.

8.1.4 The requirements for the maintenance of these notations are given in Ch 4, Sec 8, [18].

APPENDIX 1

NOTATIONS ASSIGNED ACCORDING TO EDITIONS OF THE RULES FORMER TO JUNE 2000 EDITION

1 Application for surveys and correspondence with current notations

1.1 General

1.1.1 The current edition of the Rules uses a different system of class notations, in comparison with the one in force in the editions of the Rules former to June 2000 edition.

Subarticle [1.4] gives correspondence between the notations assigned to ships according to the editions of the Rules former to June 2000 edition and the class notations assigned according to the current edition.

1.2 Phasing out from former to current notations

1.2.1 All ships admitted or being admitted to class after the effective application date of the current Rules are to be assigned class notations in accordance with Ch 1, Sec 2.

1.2.2 Ships with notations assigned in accordance with editions of the Rules former to the June 2000 edition of the Rules keep their current notations, latest until next class renewal survey.

At the class renewal survey, notations having an equivalence with the notations given in the current edition, are replaced by the corresponding notation according to tables of subarticle [1.4].

Notations indicated as having no equivalence with any notation in the current Rules are kept for the life time of the ship.

Note 1: At Owner's request, change over from former to current notations may be performed before the next class renewal survey.

1.3 Application of scope of surveys

1.3.1 For periodicity and scope of surveys for maintenance of class of ships being still assigned class notations according to editions of the Rules former to June 2000 edition, tables given in [1.4] indicate which requirements are applicable to such notations, with reference to class notations of the current Rules.

1.4 Correspondence between former and current notations

1.4.1 Tab 1 gives correspondence between former class symbols and construction marks and the current ones.

1.4.2 Tab 2 gives correspondence between former service notations and the current ones, as well as corresponding periodicity and scope of survey for maintenance of class.

Tab 3 gives correspondence between former additional service notations and the current additional service feature.

1.4.3 Tab 4 gives correspondence between former navigation notations or operating area notations and the current ones.

1.4.4 Tab 5 gives correspondence between former additional class notations or special notations and the current ones, as well as corresponding survey requirements for maintenance of class.

Table 1 : Class symbols and construction marks

Former notation	Current notation	Remarks
I 3/3	class symbol I	Validity of certificate ≤ 5 years
II 5/6, II 3/3 or I 5/6	class symbol II	Validity of certificate ≤ 3 years
E, (E) or (-)	None. A note is entered in a memoranda for notations (E) or (-)	Surveys of anchors and chains dealt with in Part A, Chapter 3
⊠, ⊠ or • placed before the service notation	⊠, ⊠ or • HULL	(1)
⊠, ⊠ or • MACH	⊠, ⊠ or • MACH	(1)
(1) No specific periodicity or scope of survey attached to such notation.		

Table 2 : Service notations

Former notation	Current notation	Periodicity and scope of surveys
bulk carrier	bulk carrier	bulk carrier ESP or general cargo ship, as applicable
bulk carrier - oil tanker	combination carrier/OBO	combination carrier/OBO
cargoship	general cargo ship	general cargo ship
chemical tanker	chemical tanker	chemical tanker
containership	container ship	container ship
deck ship	deck ship	all ships
dredger	dredger	dredger
fire fighting ship 1, 2, 3, - or water spray	fire fighting 1, 2, 3, E or water spraying	fire fighting ship 1, 2, 3, E or water spraying
fishing vessel	fishing vessel	fishing vessel
floating dock	floating dock	floating dock
hopper barge	hopper unit	hopper unit
hopper dredger	hopper dredger	hopper dredger
HSC (CAT A or CAT B)	HSC (-CAT A or -CAT B)	HSC (CAT A or CAT B)
launch, seagoing launch	launch, seagoing launch	all ships
light ship	light ship	light ship
liquefied gas carrier	liquefied gas carrier	liquefied gas carrier
livestock carrier	livestock carrier	livestock carrier
oil recovery ship	oil recovery	oil recovery ship
oil tanker	oil tanker	oil tanker
ore carrier	ore carrier	ore carrier
ore carrier - oil tanker	combination carrier/OOC	combination carrier/OOC
passenger ferry	ro-ro passenger ship	ro-ro passenger ship
passenger ship	passenger ship	passenger ship
pontoon	pontoon	pontoon
pontoon/crane or pontoon/derrick	pontoon - crane	pontoon - crane
product tanker	FLS tanker	FLS tanker
pusher	tug	tug
refrigerated carrier	refrigerated cargo ship	refrigerated cargo ship
roll on - roll off	ro-ro cargo ship	ro-ro cargo ship
special service / ...	special service - ... (1)	special service - ... (1)
split hopper barge	split hopper unit	split hopper unit
split hopper dredger	split hopper dredger	split hopper dredger
supply vessel	supply	supply vessel
tanker	tanker	tanker
tug	tug	tug
yacht	yacht -motor-S or yacht -sailing-S (2)	yacht

(1) Unless a new service notation corresponds to the specified service, such as **cable laying**.

(2) Ships assigned with the service notation charter yacht according to the Rule Note NR381 keep their service notation latest until next class renewal survey. At the next class renewal survey, or before it at Owner's request, the service notation is replaced by the current service notation as per Rule Note NR500 (charter yacht-motor-S or charter yacht-sailing-S).

Table 3 : Additional service notations - Additional service features

Former notation	Current notation (additional service feature)
/NP	- no propulsion
/AP	- assisted propulsion
/WAP	WAP
/EAWP	EAWP
ESP	ESP
flash point above 60°C	flash point > 60°C
(oil tanker) /floating storage	refer to NR445 Rules of Offshore Units, Pt D, Ch 1, Sec 1 or oil storage service
/F	none
/LNG	none
/LNG-LPG	none

Table 4 : Navigation notations and operating area notations

Former notation	Current notation
deep sea	unrestricted navigation
coastal waters	none (1)
sheltered waters	sheltered area
sea and river waters, deep sea and river waters, coastal waters and river waters, sheltered waters and river waters	none
deep sea/occasionally	temporary unrestricted navigation
dredging within 8 miles from shore	dredging within 8 miles from shore
dredging within 15 miles from shore or within 20 miles from port	dredging within 15 miles from shore or within 20 miles from port
dredging over 15 miles from shore	dredging over 15 miles from shore
(1) However, navigation notations summer zone , tropical zone and/or coastal area may be assigned by equivalence after review of the Society.	

Table 5 : Additional class notations and special notations

Former notation	Current notation	Survey requirements
ACA	LASHING	(1)
ALP, ALM, (ALP), (ALM) ALS, (ALS)	ALP, ALM, (ALP), (ALM) none (existing notation is kept)	see Rule Note NR526
ALT	nonhomload (additional service feature)	(1)
AUT, AUT-MS, AUT-CC	AUT-IMS, AUT-UMS, AUT-CCS	automated machinery systems Ch 5, Sec 4
AUT-OS	none (existing notation is kept)	automated machinery systems Ch 5, Sec 4
BRG	STRENGTHBOTTOM	STRENGTHBOTTOM Ch 5, Sec 10, [2]
CL	none (existing notation is kept)	(1)
CM1 or CM2	none (existing notation is kept)	(1)
CNC-E, CNC-1, -V	SYS-NEQ, SYS-NEQ-1 notation -V is not retained	SYS-NEQ, SYS-NEQ-1 Ch 5, Sec 5
COMFORT - 1, 2, 3	COMF-1, 2, 3	
COMFORT -n1, -n2, -n3	COMF-NOISE 1, 2, 3	
COMFORT -v1, -v2, -v3	COMF-VIB 1, 2, 3	
(1) No survey requirement attached to such notation.		
(2) However, AVM-APS , AVM-DPS or AVM-IPS may be assigned by equivalence on a case by case basis after review by the Society.		

Former notation	Current notation	Survey requirements
CSA	SDS	(1)
DEP	none (existing notation is kept) (2)	availability of machinery Ch 5, Sec 3
ETA	ETA Ships of 20000 tdw and above: existing notation is kept only until next class renewal survey and will be dropped after	see survey of emergency towing arrangement as per relevant service notation
F	none (existing notation is kept)	(1)
Heavy cargo	heavy cargo (additional service feature)	(1)
Heavy parcels on deck	heavy cargo (additional service feature)	(1)
Ice I super, Ice I, Ice II, Ice III	none (existing notation is kept)	arrangements for navigation in ice Ch 5, Sec 9
Ice Class IA Super, Ice Class IA, Ice Class IB, Ice Class IC	ICE CLASS IA SUPER, ICE CLASS IA, ICE CLASS IB, ICE CLASS IC	arrangements for navigation in ice Ch 5, Sec 9
Ice, Ice Class ID	ICE, ICE CLASS ID	arrangements for navigation in ice Ch 5, Sec 9
IG	IG For chemical tankers and oil tankers/FLS tankers for which an inert gas system is required by the Rules, the existing notation is kept only until next class renewal survey and will be dropped after	see survey of inert gas installation as per relevant service notation assigned
INT	none (existing notation is kept)	(1)
OIL POL-ENG, OIL POL-CARG, NLS-POL	none (existing notation is kept only until next class renewal survey and will be dropped after)	(1)
PDY	DYNAPOS	DYNAPOS Ch 5, Sec 10, [5]
PFA	none (existing notation is kept only until next class renewal survey and will be dropped after)	see survey of internal platforms and ramps in Ch 4, Sec 6
PORT	AUT-PORT	automated machinery systems Ch 5, Sec 4
PST, LCDT	none (existing notation is kept)	(1)
PTR	none (existing notation is kept)	survey of thruster installation (all ships)
(RMC) -A	none (existing notation is kept)	(1)
(RMC) /precooling, /quick freezing plant, /CA	-PRECOOLING, -QUICKFREEZE, -AIRCONT	refrigerating installations Ch 5, Sec 8
RMC, RMC-C, RMC-V	REF-CARGO, REF-CONT, REF-STORE	refrigerating installations Ch 5, Sec 8
RMC-S	none (existing notation is kept)	refrigerating installations Ch 5, Sec 8
SPM	SPM	SPM Ch 5, Sec 10, [4]
TOR, TOR-F	none (existing notation is kept)	(1)
Veristar notations hull and machinery	VeriSTAR-HULL, VeriSTAR-HULL SIS, STAR-MACH, STAR-MACH SIS, STAR SIS	VeriSTAR system Ch 5, Sec 2
(1) No survey requirement attached to such notation.		
(2) However, AVM-APS, AVM-DPS or AVM-IPS may be assigned by equivalence on a case by case basis after review by the Society.		

ASSIGNMENT, MAINTENANCE, SUSPENSION AND WITHDRAWAL OF CLASS

SECTION 1	ASSIGNMENT OF CLASS
SECTION 2	MAINTENANCE OF CLASS
SECTION 3	SUSPENSION AND WITHDRAWAL OF CLASS
APPENDIX 1	PLANNED MAINTENANCE SURVEY SYSTEM
APPENDIX 2	CSM AND PMS SYSTEMS: SURVEYS CARRIED OUT BY THE CHIEF ENGINEER
APPENDIX 3	THICKNESS MEASUREMENTS: EXTENT, DETERMINATION OF LOCATIONS, ACCEPTANCE CRITERIA
APPENDIX 4	CONDITION MONITORING AND CONDITION BASED MAINTENANCE

SECTION 1

ASSIGNMENT OF CLASS

1 General

1.1

1.1.1 Class is assigned to a ship upon a survey, with the associated operations, which is held in order to verify whether it is eligible to be classed on the basis of the Rules of the Society (see Ch 1, Sec 1, [1.3.2]). This may be achieved through:

- the completion of the new building, during which a survey has been performed
- a survey carried out according to the agreement developed by the IACS Member Societies when ships change class between members, or
- a specific admission to class survey, in cases where a ship is classed with a non-IACS Society or is not classed at all.

2 New building procedure

2.1 Ships surveyed by the Society during construction

2.1.1 When a ship is surveyed by the Society during construction, it is to comply with those requirements of the Rules which are in force and applicable depending on the class of the ship, taking into account the provisions of Ch 1, Sec 1, [2.1] and Ch 1, Sec 1, [2.2].

The hull surveys for new constructions are to be carried out in accordance with the requirements of Ch 3, Sec 7.

2.1.2 The Society:

- approves the plans and documentation submitted as required by the Rules
- proceeds, if required, with the appraisal of the design of materials and equipment used in the construction of the ship and their inspection at works
- carries out surveys, attends tests and trials provided for in the Rules, or obtains appropriate evidence to satisfy itself that the scantlings and construction meet the rule requirements in relation to the approved drawings
- assigns the construction mark \boxtimes ; refer to Ch 1, Sec 2, [3.2.1].

2.1.3 The Society defines in specific Rules which materials and equipment used for the construction of ships built under survey are, as a rule, subject to appraisal of their design and to inspection at works, and according to which particulars.

2.1.4 As part of his interventions during the ship's construction and subject to the provisions of [2.1.2], the Surveyor will:

- conduct an overall examination of the parts of the ship covered by the Rules
- examine the construction methods and procedures when required by the Rules
- check selected items covered by the rule requirements
- attend tests and trials where applicable and deemed necessary.

2.1.5 Use of materials, machinery, appliances and items

As a general rule, all materials, machinery, boilers, auxiliary installations, equipment, items etc. (generally referred to as "products") which are covered by the class and used or fitted on board ships surveyed by the Society during construction are to be new and, where intended for essential services as defined in Ch 1, Sec 1, [1.2.1], tested by the Society.

Second hand materials, machinery, appliances and items may be used subject to the specific agreement of the Society and the Owner.

The requirements for the selection of materials to be used in the construction of the various parts of a ship, the characteristics of products to be used for such parts and the checks required for their acceptance are to be as stated in Part C of the Rules (NR467) and in NR216 Materials and Welding, as applicable, or in other Parts of NR467, or as specified on approved plans. In particular, the testing of products manufactured according to quality assurance procedures approved by the Society and the approval of such procedures are governed by the requirements of NR216 Materials and Welding, Ch 1, Sec 1, [3].

Attention is drawn to the provisions of the EC Regulation 391/2009, specifically Article 10.

2.1.6 Defects or deficiencies and their repair

The Society may, at any time, reject items found to be defective or contrary to rule requirements or require supplementary inspections and tests and/or modifications, notwithstanding any previous certificates issued.

All repairs are subject to the preliminary agreement of the Society. When the limits of tolerance for defects are specified in the Rules concerned or by the Manufacturer, they are to be taken into account for repairs.

It is incumbent upon the Interested Party to notify the Society of any defects noted during the construction of the ship and/or of any item not complying with the applicable requirements or in any case unsatisfactory. Proposals regarding remedial actions intended to be adopted to eliminate such defects or unsatisfactory items are to be submitted to the Society and, if accepted, carried out to the Surveyor's satisfaction.

2.1.7 Equivalence of Rule testing under certain conditions

Notwithstanding the provisions of [2.1.4], the Society may, at its discretion and subject to conditions and checks deemed appropriate, accept certain materials, appliances or machinery which have not been subjected to rule testing.

2.2 Other cases

2.2.1 When the procedure adopted does not comply with that detailed in [2.1] but the Society deems that it is acceptable for the assignment of class, the construction mark • is assigned in accordance with Ch 1, Sec 2, [3.2.3].

2.3 Documentation

2.3.1 Documentation relevant to the class applied for is to be submitted for the approval of the Society.

2.3.2 The design data, calculations and plans to be submitted are listed in the relevant chapters of the Rules.

The Society may also call for additional information according to the specific nature of the ship to be classed.

2.3.3 The documentation submitted to the Society is examined in relation to the class applied for in the request for classification.

Note 1: Should the Interested Party subsequently wish to have the class, in particular the service notation or navigation notation, granted to the ship modified, plans and drawings are generally to be re-examined.

2.3.4 A copy of the submitted plans will be returned duly stamped, with remarks related to the compliance with the rule requirements should the need arise.

2.3.5 As a rule, modifications of the approved plans regarding items covered by classification are to be submitted.

2.3.6 Design data to be submitted to the Society are to incorporate all information necessary for the assessment of the design of the ship for the purpose of assignment of class. It is the responsibility of the Interested Party to ascertain that the design data are correct, complete and compatible with the use of the ship.

2.3.7 Design calculations are to be provided, when called for, as supporting documents to the submitted plans.

2.3.8 Design data and calculations are to be adequately referenced. It is the duty of the Interested Party to ascertain that the references used are correct, complete and applicable to the design of the ship.

2.3.9 The submitted plans are to contain all necessary information for checking the compliance with the requirements of the Rules.

2.3.10 In the case of conflicting information, submitted documentation will be considered in the following order of precedence: design data, plans, design calculations.

2.3.11 It is the responsibility of the Interested Party to ascertain that drawings used for the procurement, construction and other works are in accordance with the approved plans.

3 Ships classed after construction

3.1 General

3.1.1 When an Owner applies to the Society for a ship already in service to be admitted to class, the application will be processed differently depending on whether the ship is:

- classed with an IACS Society, or
- not classed with an IACS Society.

3.2 Ships classed with a Classification Society subject to compliance with QSCS, reported as compliant by the Losing Society

3.2.1 In this case, ships will be admitted to the Society's class upon satisfactory surveys and verification of documentation. For the extent and scope of the surveys to be carried out and the list of documentation to be submitted by the Interested Party, reference is to be made to [3.2.3], [3.2.4] and [3.2.5].

Note 1: For transfer of class at ship's delivery, specific procedures apply.

Note 2: Compliant ship means a ship classed with a Classification Society subject to verification of compliance with QSCS and in full compliance with all applicable and relevant IACS Resolutions.

3.2.2 Surveys principle

Surveys to be carried out are based on the age of the ship and the updated current class status as provided by the previous IACS Member Society. The extent of these surveys is to be at least as contained in [3.2.3] and in [3.2.4].

3.2.3 Hull surveys

- a) For vessels of age less than 5 years, the survey is to take the form of an annual survey
- b) For vessels between 5 and 10 years of age, in addition, the survey is to include the inspection of a representative number of ballast spaces
- c) For vessels of 10 years of age and above but less than 20 years of age, in addition, the survey is to include the inspection of a representative number of cargo spaces, except for:
 - For gas carriers, in lieu of internal inspection of cargo spaces, the following applies:
 - inspection of surrounding ballast tank(s), including external inspection of independent cargo tank(s) and supporting systems as far as possible
 - review of cargo log books and operational records to verify correct functioning of the cargo containment system.
 - For chemical tankers of 10 years and above but less than 15 years of age, in lieu of an internal inspection of cargo tanks without internal stiffening and framing, inspections of surrounding ballast tank(s) and void spaces and deck structure, are to be applied.

- d) For vessels with notation **ESP**, which are 15 years of age and above, but less than 20 years of age, the survey is to have the scope of a class renewal survey or an intermediate survey, whichever is due next
- e) For all vessels which are 20 years of age and above, the survey is to have the scope of a class renewal survey (this requirement is also applicable to ships having their hull under continuous survey)
- f) In lieu of the requirements in items a) through e) above, the following apply for site specific purpose-built Floating Production and/or Storage Vessels:
- for vessels of age less than 5 years, the survey is to have the scope of an annual survey
 - for vessels of age between 5 and 10 years, in addition, the survey is to include the inspection of twenty percent of ballast spaces
 - for vessels of age between 10 and 20 years, in addition, the survey is to include twenty percent of cargo spaces
 - for vessels over 20 years of age, the survey is to have the scope of a class renewal survey.
- g) For site specific Floating Production and/or Storage Vessels which have been converted from other vessels, the survey is to take form of an annual survey and also include inspection of twenty percent of ballast spaces and twenty percent of cargo spaces until 20 years have elapsed since conversion. After 20 years the survey is to have the scope of a class renewal survey.
- h) In the context of applying items d) and e) above, if a dry-docking of the vessel is not due at time of transfer, consideration can be given to carrying out an underwater examination in lieu of dry-docking
- i) In the context of applying items d) and e) above, as applicable, the anchors and anchor chain cables ranging and gauging for vessels over 15 years of age is not required to be carried out as part of the class entry survey unless the class entry survey is being credited as a periodical survey for maintenance of class. If the class entry survey is to be credited as a periodical survey of maintenance of class, consideration may be given by the gaining society to the acceptance of the anchors and anchor chain cables ranging and gauging carried out by the losing society provided they were carried out within the applicable survey window of the periodical survey in question
- j) In the context of applying items a) to h) above, as applicable:
- if the class entry survey is to be credited as a periodical survey for maintenance of class, consideration may be given by the gaining society to the acceptance of thickness measurements taken by the losing society provided they were carried out within the applicable survey window of the periodical survey in question.
 - if the class entry survey is not to be credited as a periodical survey for maintenance of class, consideration may be given by the gaining society to the acceptance of thickness measurements taken by the

losing society provided they were carried out within 15 months prior to completion of class entry survey when it is in the scope of a class renewal survey, within 18 months prior to the completion of class entry survey when it is in the scope of an intermediate survey.

In both cases, the thickness measurements are to be reviewed by the gaining society for compliance with the applicable survey requirements, and confirmatory gauging are to be taken to the satisfaction of the gaining society.

- k) In the context of applying c) to h) above, as applicable, tank testing for vessels over 15 years of age is not required to be carried out as part of class entry survey unless the class entry survey is being credited as a periodical survey for the maintenance of class. If the class entry survey is to be credited as a periodical survey for maintenance of class, consideration may be given by the gaining society provided they were carried out within the applicable survey window of the periodical survey in question.
- l) In the context of applying a) to h) above, as applicable, compliance with IACS Unified Requirements that require compliance at the forthcoming due periodical survey (such as UR S26 and S27) are not required to be carried out /completed as part of the class entry survey unless the class entry survey is credited as a periodical survey for maintenance of class.

3.2.4 Machinery surveys

A general examination of all essential machinery is to be held including at least the following:

- a) Examination under working condition of oil fuel burning equipment, boilers, economizers and steam/steam generators. The adjustment of safety valves of this equipment is to be verified by checking the records on board ship
- b) All pressure vessels are to be examined
- c) Insulation resistance, generator circuit breakers, preference tripping relays and generator prime mover governors are to be tested and paralleling and load sharing to be proved
- d) In all cases, navigating lights and indicators are to be examined and their working and alternative sources of power verified
- e) Bilge pumps, emergency fire pumps and remote controls for oil valves, oil fuel pumps, lubricating oil pumps and forced draught fans are to be examined under working condition
- f) Recirculating and ice clearing arrangements, if any
- g) The main and all auxiliary machinery necessary for operation of the ship at sea together with essential controls and steering gear is to be tested under working conditions. Alternative means of steering are to be tested
- h) A short sea trial is to be held, at the Surveyor's discretion, if the ship has been laid up for a long period
- i) Initial start arrangements are to be verified

- j) In the case of oil tankers, the cargo oil system and electrical installations in way of hazardous spaces are to be checked for compliance with rule requirements. Where intrinsically safe equipment is installed, the Surveyors are to satisfy themselves that such equipment has been approved by a recognised authority. The safety devices, alarms and essential instruments of the inert gas system are to be verified and the plant generally examined to ensure that it does not constitute a hazard to the ship.

Note 1: For the transfer of class or adding class at ship's delivery, items c) and j) may be verified by reviewing the ship's record.

3.2.5 Documentation

As a rule, the documentation to be supplied is the following.

- a) Main plans:
- General arrangement
 - Capacity plan
 - Hydrostatic curves
 - Loading manual, where required
 - Damage stability calculation, where required.
- b) Hull structure plans:
- Midship section
 - Scantling plan
 - Decks
 - Shell expansion
 - Transverse bulkheads
 - Rudder and rudder stock
 - Hatch covers
 - For ship assigned with the additional service feature **CSR**, plans showing, for each structural element, both as-built and renewal thicknesses and any thickness for "voluntary addition".
- c) Machinery plans:
- Machinery arrangement
 - Intermediate, thrust and screw shafts
 - Propeller
 - Main engines, propulsion gears and clutch systems (or Manufacturer's make, model and rating information)
 - For steam turbine ships, main boilers, superheaters and economisers (or Manufacturer's make, model and rating information) and steam piping
 - Bilge and ballast piping diagram
 - Wiring diagram
 - Steering gear system piping and arrangements and steering gear Manufacturer's make and model information
 - Torsion vibration calculations, for ships less than two years old
 - Plans for flexible couplings and/or torque limiting shafting devices in the propulsion line shafting (or Manufacturer's make, model and rating information), for ships assigned with one of the ice class additional class notations described in Ch 1, Sec 2, [6.10.2]

- Pumping arrangements at the forward and after ends, drainage of cofferdams and pump rooms and general arrangements of cargo piping in tanks and on decks, for oil tankers.
- d) Plans required for ships assigned one of the additional class notations for Automated Machinery Systems:
- Instrument list
 - Fire alarm system
 - Plans for systematic maintenance and functioning tests.
- e) Additional documents required for approval of alternative design and arrangements.
- f) Document(s) of approval of alternative design and arrangements are to be submitted, if any.
- g) Structural fire protection and fire control plan.

Alternative technical data may be accepted by the Society in lieu of specific items of the listed documentation not available at the time of the transfer of class.

3.2.6 For ships of less than 100 gross tonnage, special consideration will be given to the scope of surveys and documentation to be supplied.

3.3 Non-compliant ships

3.3.1 In this case, the class of the ship will be assigned upon a preliminary review of the documentation listed in [3.3.3] and subsequent satisfactory completion of the surveys, the extent and scope of which are given below.

Note 1: Non-compliant ship means a ship either not classed with a Classification Society subject to verification of compliance with QSCS or not in full compliance with all applicable and relevant IACS Resolutions.

3.3.2 Surveys

The extent and scope of the admission to class survey are to be not less than those required at the class renewal survey of a ship of the same age and type; in addition all other periodical surveys should be performed together with those inspections which are linked to specific service notations and/or additional class notations and/or special installations the ship is provided with.

3.3.3 Documentation

As a general rule, the documentation to be supplied to the Society is not to be less than the following.

- a) Main plans:
- General arrangement
 - Capacity plan
 - Loading cases, calculations of still water bending moments, and relevant documents, particulars of loading calculator and instruction booklet as per Society's requirements, according to the case
 - Stability documents, if applicable (refer to Part B, Chapter 3).

- b) Hull structure plans:
- Midship section
 - Profile and deck plan
 - Watertight bulkheads
 - Rudder and rudder stock
 - Shell expansion
 - Hatch covers
 - Stern frame.
- c) Machinery plans:
- Engine room general arrangement
 - Diagram of fuel- (transfer, service), bilge-, ballast-, lubricating oil-, cooling-, steam- and feed-, general service and starting compressed air piping
 - Diagram of fire-fighting systems
 - Drawings of boilers and air receivers
 - Drawings of shaft line, reduction gear and propeller
 - Drawings of steering gear
 - Torsion vibration calculations as per conditions laid down in Pt C, Ch 1, Sec 9. Such documents are required only for ships less than 2 years old or for older ships the propelling system of which has been modified during the two years preceding the classification.
- d) Electrical installation plans:
- Master plan of power distribution, lighting and emergency power circuits
 - Single line diagram of networks and switchboards
 - Location and arrangement of electrical equipment in hazardous areas.
- e) Structural fire protection and fire control plan.

Alternative technical data may be accepted by the Society in lieu of specific items of the listed documentation not available at the time of the transfer of class.

3.3.4 Where appropriate within reasonable limits, a proven service record of satisfactory performance during a period of adequate length may be used as a criterion of equivalence. Special consideration will be given to ships of recent construction.

3.3.5 For installations or equipment covered by additional service and/or class notations, the Society will determine the documentation to be submitted.

3.3.6 In addition, the Society may base its judgement upon documentation such as certificates issued or accepted by the former Classification Society, if any, and statutory certificates issued by the flag Administration or by a recognised organisation on its behalf; moreover, other documents and/or plans may be specifically required to be supplied to the Society in individual cases.

4 Date of initial classification

4.1 Definitions

4.1.1 Date of build

For a new building the date of build is the year and month at which the new construction survey process is completed. Where there is a substantial delay between the completion of the construction survey process and the ship commencing active service, the date of commissioning may be also specified.

If modifications are carried out, the date of build remains assigned to the ship. Where a complete replacement or addition of a major portion of the ship is involved, the following applies:

- the date of build associated with each major portion of the ship is to be indicated on the Classification Certificate and in the Register, where it has been agreed that the newer structure shall be on a different survey cycle
- survey requirements are to be based on the date of build associated with each major portion of the ship
- survey due dates may be aligned at the discretion of the Society.

Note 1: For example, a major portion of the ship may include a complete forward or after section, a complete main cargo section (which may include a complete hold / tank of a cargo ship), a complete block of deck structure of a passenger ship or a structural modification of a single hull to a double hull ship.

4.1.2 Date of initial classification for new buildings

As a general rule, for new buildings the date of initial classification coincides with the date of build.

4.1.3 Date of initial classification for existing ships

In principle, for existing ships the date of initial classification is the date of completion of the admission to class survey.

5 Reassignment of class

5.1

5.1.1 At the request of the Owner, a ship which was previously classed with the Society, subsequently withdrawn from class and has not been classed since may have the class reassigned subject to an admission to class survey. If applicable and appropriate, account may be taken of any periodical surveys held in the former period of class with the Society.

SECTION 2 MAINTENANCE OF CLASS

1 General principles of surveys

1.1 Survey types

1.1.1 Classed ships are submitted to surveys for the maintenance of class. These surveys include the class renewal survey, intermediate and annual survey, bottom survey (either survey in dry condition or in-water survey), tailshaft survey, boiler survey, and surveys for the maintenance of additional class notations, where applicable. Such surveys are carried out at the intervals and under the conditions laid down in this Section. In addition to the above periodical surveys, ships are to be submitted to occasional surveys whenever the circumstances so require; refer to [6], also when the Owner requires a specific survey in case of sales; refer to Article [7].

1.1.2 The different types of periodical surveys are summarised in Tab 1. The intervals at which the periodical surveys are carried out are given in the items referred to in the second column of Tab 1. The relevant extent and scope are given in Part A, Chapter 3 and Part A, Chapter 4 for all ships and for service notations, respectively, while surveys related to additional class notations are given in Part A, Chapter 5.

Where there are no specific survey requirements for additional class notations assigned to a ship, equipment and/or arrangements related to these additional class notations are to be examined, as applicable, to the Surveyor's satisfaction at each class renewal survey for the class.

The surveys are to be carried out in accordance with the relevant requirements in order to confirm that the hull, machinery, equipment and appliances comply with the applicable Rules and will remain in satisfactory condition based on the understanding and assumptions mentioned in Ch 1, Sec 1, [3.3].

Where the conditions for the maintenance of the class, service notations and additional class notations are not complied with, the class and/or the service notation and/or the additional class notations as appropriate will be suspended and/or withdrawn in accordance with the applicable Rules given in Ch 2, Sec 3.

Note 1: It is understood that requirements for surveys apply to those items that are required according to the Rules or, even if not required, are fitted on board.

1.1.3 Unless specified otherwise, any survey other than bottom survey and tailshaft survey may be effected by carrying out partial surveys at different times to be agreed upon with the Society, provided that each partial survey is adequately extensive. The splitting of a survey into partial surveys is to be such as not to impair its effectiveness.

1.1.4 Special consideration may be given in application of Ch 3, Sec 1 to Ch 3, Sec 6 to commercial ships owned or chartered by Administrations, which are utilized in support of military operations or service.

Table 1 : List of periodical surveys

Type of survey	Reference in this Section	Reference to scope of survey
Class renewal - hull	[4]	Ch 3, Sec 3 and Part A, Chapter 4 (1)
Class renewal - machinery	[4]	Ch 3, Sec 3 and Part A, Chapter 4 (1)
Class renewal - additional class notations	[1.1]	Part A, Chapter 5 (2)
Annual - hull	[5.2]	Ch 3, Sec 1 and Part A, Chapter 4 (1)
Annual - machinery	[5.2]	Ch 3, Sec 1 and Part A, Chapter 4 (1)
Annual - additional class notations	[1.1]	Part A, Chapter 5 (2)
Intermediate - hull	[5.3]	Ch 3, Sec 2 and Part A, Chapter 4 (1)
Intermediate - machinery	[5.3]	Ch 3, Sec 2 and Part A, Chapter 4 (1)
Bottom - dry condition	[5.4]	Ch 3, Sec 4
Bottom - in water	[5.4]	Ch 3, Sec 4
Tailshaft - complete	[5.5]	Ch 3, Sec 5
Tailshaft - modified	[5.5]	Ch 3, Sec 5
Boiler - complete	[5.6]	Ch 3, Sec 6
(1) As applicable, according to the service notation assigned to the ship.		
(2) As applicable, according to the additional class notations assigned to the ship.		

1.2 Change of periodicity, postponement or advance of surveys

1.2.1 The Society reserves the right, after due consideration, to change the periodicity, postpone or advance surveys, taking into account particular circumstances.

1.2.2 When a survey becomes overdue during a voyage, the following applies:

- a) In the case of a class renewal survey, the Society may grant an extension to allow for completion of the class renewal survey, provided there is documented agreement to such an extension prior to the expiry date of the Certificate of Classification, adequate arrangements have been made for attendance of the Surveyor at the first port of call and the Society is satisfied that there is technical justification for such an extension. Such an extension will be granted only until arrival at the first port of call after the expiry date of the Certificate of Classification.

However, if owing to “exceptional circumstances” as defined in [2.1.7], the class renewal survey cannot be completed at the first port of call, the Society may grant an extension according to [4.1.1], but the total period of extension shall in no case be longer than three months after the original limit date of the class renewal survey.

- b) In the case of annual and intermediate surveys, no postponement is granted. Such surveys are to be completed within their prescribed windows; see [2.1.3].
- c) In the case of all other periodical surveys and conditions of class, extension of class may be granted until the arrival of the ship at the port of destination.

1.3 Extension of scope of survey

1.3.1 The Society and/or its Surveyors may extend the scope of the provisions in Part A, Chapter 3 to Part A, Chapter 5, which set forth the technical requirements for surveys, whenever and so far as considered necessary, or modify them in the case of special ships or systems.

1.3.2 The extent of any survey also depends upon the condition of the ship and its equipment. Should the Surveyor have any doubt as to the maintenance or condition of the ship or its equipment, or be advised of any deficiency or damage which may affect the class, then further examination and testing may be conducted as considered necessary.

1.4 General procedure of survey

1.4.1 The general procedure of survey consists in:

- an overall examination of the parts of the ship covered by the rule requirements
- checking selected items covered by the rule requirements
- attending tests and trials where applicable and deemed necessary by the Surveyor.

1.4.2 When a survey results in the identification of significant corrosion, structural defects or damage to hull, machinery and/or any piece of its equipment which, in the opinion of the Surveyor, affect the ship's class, remedial measures are to be implemented before the ship continues in service (see also [2.11]).

Note 1: The Society's survey requirements cannot be considered as a substitute for specification and acceptance of repairs and maintenance, which remain the responsibility of the Owner.

Note 2: In accordance with the provisions of Ch 1, Sec 1, [4.1.3], the Society will, at the request of the Owner, apply the regulations of Administrations concerning the scope and periodicity of surveys when they differ from those laid down in [4] and [5].

Note 3: During the surveys, the Surveyor does not check that the spare parts are kept on board, maintained in working order and suitably protected and lashed.

1.5 Appointment of another Surveyor

1.5.1 In compliance with the provisions of Ch 1, Sec 1, [2.4.1], should a disagreement arise between the Owner and the Surveyor during a survey, the Society may, at the request of the Owner, designate another Surveyor.

2 Definitions and procedures related to surveys

2.1 General

2.1.1 Period of class

Period of class means the period starting either from the date of the initial classification, see Ch 2, Sec 1, [4], or from the credited date of the last class renewal survey, and expiring at the limit date assigned for the next class renewal survey.

2.1.2 Anniversary date

Anniversary date means the day of the month of each year in the period of class which corresponds to the expiry date of the period of class.

2.1.3 Survey time window

Survey time window, or more simply window, mean the fixed period during which annual and intermediate surveys are to be carried out.

2.1.4 Overdue surveys

Each periodical survey is assigned a limit date specified by the relevant requirements of the Rules (end of survey interval or end date of window) by which it is to be completed.

A survey becomes overdue when it has not been completed by its limit date.

Examples:

- Anniversary date: 15th April

The 2000 annual survey can be validly carried out from 16th January 2000 to 15th July 2000. If not completed by 15th July 2000, the annual survey becomes overdue.

- Last bottom survey 20th October 2000:

If not completed by 20th October 2003 or end of the class period, whichever comes first, the bottom survey becomes overdue.

2.1.5 Condition of class

A defect and/or deficiency to be dealt with in order to maintain class, within a specific period of time, is indicated as a condition of class. A condition of class is pending until it is cleared, through a survey by the attending Surveyor or upon evidence that requirements have been completed, to the satisfaction of the Society. Where it is not cleared by its limit date, the condition of class is overdue.

Condition of class may be imposed in other cases, which, in the Society's opinion, require specific consideration.

2.1.6 Memoranda

Those defects and/or deficiencies which do not affect the maintenance of class and which may therefore be cleared at the Owner's convenience and any other information deemed noteworthy for the Society's convenience are indicated as memoranda. Memoranda are not to be regarded as condition of class.

2.1.7 Exceptional circumstances

"Exceptional circumstances" means:

- unavailability of dry-docking facilities, or
- unavailability of repair facilities, or
- unavailability of essential materials, equipment or spare parts, or
- delays incurred by action taken to avoid severe weather conditions.

2.2 Terminology related to hull survey

2.2.1 Ballast tank

A ballast tank is a tank that is being used primarily for salt water ballast.

For single skin and double skin bulk carriers subject to the requirements of Ch 4, Sec 2, a ballast tank is a tank which is used solely for salt water ballast, or, where applicable, a space which is used for both cargo and salt water ballast will be treated as a ballast tank when substantial corrosion has been found in that space, see [2.2.7]. For double skin bulk carriers, a double side tank is to be considered as a separate tank even if it is in connection to either the topside tank or the hopper side tank.

For oil tankers subject to the requirements of Ch 4, Sec 3 and chemical tankers subject to the requirements of Ch 4, Sec 4, a ballast tank is a tank which is used solely for the carriage of salt water ballast. A combined cargo/ballast tank is a tank which is used for the carriage of cargo or ballast water as a routine part of the vessel's operation and will be treated as a ballast tank. Cargo tanks in which water ballast might be carried only in exceptional cases per MARPOL I/18(3) are to be treated as cargo tanks.

2.2.2 Spaces

Spaces are separate compartments including holds and tanks.

For ships subject to Ch 4, Sec 2, spaces are separate compartments including holds, tanks, cofferdams and void spaces bounding cargo holds, decks and the outer hull.

2.2.3 Overall survey

An overall survey is a survey intended to report on the overall condition of the hull structure and determine the extent of additional close-up surveys.

2.2.4 Close-up survey

A close-up survey is a survey where the details of structural components are within the close visual inspection range of the Surveyor, i.e. normally within reach of hand.

2.2.5 Transverse section

A transverse section includes all longitudinal members contributing to longitudinal hull girder strength, such as plating, longitudinals and girders at the deck, sides, bottom, inner bottom, longitudinal bulkheads and, as applicable for the different ship types, relevant longitudinals, hopper sides, bottom in top wing tanks, inner sides. For a transversely framed ship, a transverse section includes adjacent frames and their end connections in way of transverse sections.

2.2.6 Representative tanks or spaces

Representative tanks or spaces are those which are expected to reflect the condition of other tanks or spaces of similar type and service and with similar corrosion prevention systems. When selecting representative tanks or spaces, account is to be taken of the service and repair history on board and identifiable critical structural areas and/or suspect areas.

2.2.7 Substantial corrosion

Substantial corrosion is an extent of corrosion such that assessment of the corrosion pattern indicates a wastage in excess of 75% of allowable margins, but within the acceptable limits.

For the following ships:

- bulk carriers built under Common Structural Rules for Bulk Carriers (NR522), or
- oil tankers built under Common Structural Rules for Double Hull Oil Tankers (NR523), or
- bulk carriers or oil tankers built under Common Structural Rules for Bulk Carriers and Oil Tankers (NR606), or
- container ships with a length greater than 65 m and contracted for construction on or after 1st July 2016,

substantial corrosion is an extent of corrosion such that the assessment of the corrosion pattern indicates a measured thickness between $(t_{\text{renewal}} + 0,5 \text{ mm})$ and t_{renewal} .

Note 1: t_{renewal} is the minimum allowable thickness, in mm, below which renewal of structural members is to be carried out.

2.2.8 Pitting corrosion

Pitting corrosion is defined as scattered corrosion spots/ areas with local material reductions which are greater than the general corrosion in the surrounding area. Pitting intensity is defined in Ch 2, App 3, Fig 22.

2.2.9 Edge corrosion

Edge corrosion is defined as local corrosion at the free edges of plates, stiffeners, primary support members and around openings, as shown in Ch 2, App 3, Fig 15.

2.2.10 Grooving corrosion

Grooving corrosion is typically local material loss adjacent to weld joints along abutting stiffeners and at stiffeners or plate butts or seams, as shown in Ch 2, App 3, Fig 16.

2.2.11 Suspect areas

Suspect areas are locations showing substantial corrosion and/or considered by the Surveyor to be prone to rapid wastage.

2.2.12 Critical structural areas

Critical structural areas are locations which have been identified from calculations to require monitoring or from the service history of the subject ship or from similar ships or sister ships (if available), to be sensitive to cracking, buckling or corrosion which would impair the structural integrity of the ship.

2.2.13 Corrosion prevention system

A corrosion prevention system is normally considered a full hard protective coating.

Hard protective coating is usually to be epoxy coating or equivalent. Other coating systems, which are neither soft nor semi-hard coatings, may be considered acceptable as alternatives, provided that they are applied and maintained in compliance with the Manufacturer's specifications.

2.2.14 Coating condition

Coating condition is defined as follows:

- good: condition with only minor spot rusting
- fair: condition with local breakdown at edges of stiffeners and weld connections and/or light rusting over 20% or more of areas under consideration, but less than as defined for poor condition
- poor: condition with general breakdown of coating over 20% or more or hard scale at 10% or more, of areas under consideration.

2.2.15 Cargo area (ships carrying liquid cargo in bulk)

The cargo area is that part of the ship which contains cargo tanks, slop tanks and cargo/ballast pump rooms, compressor rooms, cofferdams, ballast tanks and void spaces adjacent to cargo tanks and also deck areas throughout the entire length and breadth of the part of the ship over the above-mentioned spaces.

2.2.16 Cargo length area (dry cargo ships)

The cargo length area is that part of the ship which includes cargo holds and adjacent areas including fuel tanks, cofferdams, ballast tanks and void spaces.

2.2.17 Prompt and thorough repair

A "Prompt and thorough repair" is a permanent repair completed at the time of survey to the satisfaction of the Surveyor, therein removing the need for the imposition of any associated condition of class. See also [2.11].

2.2.18 Special consideration

Special consideration or specially considered (in connection with close-up surveys and thickness measurements) means sufficient close-up inspection and thickness measurements are to be taken to confirm the actual average condition of the structure under the coating.

2.2.19 Air pipe head

Air pipe heads installed on the exposed decks are those extending above the freeboard deck or superstructure decks.

2.2.20 Remote inspection techniques (RIT)

Remote inspection techniques is a means of survey that enables examination of any part of the structure without the need for direct physical access of the Surveyor (refer to IACS Recommendation 42, "Guidelines for use of remote inspection techniques for surveys").

2.3 Procedures for thickness measurements

2.3.1 When required as per the scope of surveys defined below, thickness measurements are normally to be carried out under the responsibility of the Owner, and in the presence of the Surveyor, by a service supplier independent from the Owner.

2.3.2 For all ships, the following applies:

- thickness measurements required in the context of surveys of hull structure is to be witnessed by a Surveyor. This requires the Surveyor to be on board while the gaugings are taken, enabling him at any time to intervene and to control the process.
- prior to commencement of the intermediate or class renewal survey, a meeting is to be held between the attending Surveyor(s), the master of the ship or an appropriately qualified representative appointed by the master or Company, the Owner's representative(s) in attendance and the thickness measurement firm's representative(s) so as to ensure the safe and efficient execution of the surveys and thickness measurements to be carried out onboard.

2.3.3 In any kind of survey, i.e. class renewal, intermediate, annual or other surveys having the same scope, thickness measurements of structures in areas where close-up surveys are required, are to be carried out simultaneously with close-up surveys.

2.3.4 Consideration may be given by the attending Surveyor to allow the use of Remote Inspection Techniques (RIT) as an alternative to close-up survey. Surveys conducted using a RIT are to be completed to the satisfaction of the attending Surveyor. When RIT is used for a close-up survey, temporary means of access for the corresponding thickness measurements is to be provided unless such RIT is also able to carry out the required thickness measurements.

Note 1: Use of RIT as an alternative to close-up survey is not allowed for ships assigned with the service notation **bulk carrier ESP** or **bulk carrier BC-A ESP** or **bulk carrier BC-B ESP** or **bulk carrier BC-C ESP** or **self-unloading bulk carrier ESP** or **ore carrier ESP** or **combination carrier/OBO ESP** or **combination carrier/OOC ESP** or **oil tanker ESP**.

2.3.5 For structure built with a material other than steel, alternative thickness measurement requirements may be developed and applied as deemed necessary by the Society.

2.3.6 Thickness measurement is normally to be carried out by means of ultrasonic test equipment. The accuracy of the equipment is to be proven to the Surveyor as required. The thickness measurements are to be carried out by a company authorised by the Society.

The Society reserves the right to limit the scope of authorisation of the Company.

Note 1: Rule Note NR533 Approval of Service Suppliers gives details about the authorisation.

2.3.7 A thickness measurement report is to be prepared. The report is to give the location of measurements, the thickness measured and the corresponding original thickness. Furthermore, the report is to include the date when the measurements were carried out, the type of measuring equipment, the names and the qualification of the operators and their signatures.

The Surveyor is to review the final thickness measurement report and countersign the cover page.

2.3.8 For acceptance criteria applicable to structural corrosion diminution levels, reference is to be made to Ch 2, App 3.

2.4 Agreement of firms for in-water survey

2.4.1 The in-water surveys referred to in the Rules are to be carried out by a certified company accepted by the Society.

Note 1: Rule Note NR533 Approval of Service Suppliers gives details about the certification.

2.5 Preparations and conditions for surveys

2.5.1 The Owner is to provide the necessary facilities for the safe execution of the surveys, as per Ch 1, Sec 1, [3.2.2].

2.5.2 Cargo holds, tanks and spaces are to be safe for access. Cargo holds, tanks and spaces are to be gas free and properly ventilated. Prior to entering a tank, void or enclosed space, it is to be verified that the atmosphere in the tank or space is free from hazardous gas and contains sufficient oxygen.

In preparation for survey and thickness measurements and to allow for a thorough examination, all spaces are to be cleaned including removal from surfaces of all loose accumulated corrosion scale. Spaces are to be sufficiently clean and free from water, scale, dirt, oil residues, etc. to reveal corrosion, deformation, fractures, damages or other structural deterioration as well as the condition of the coating. However, those areas of structure whose renewal has already been decided by the Owner need only be cleaned and descaled to the extent necessary to determine the limits of the areas to be renewed.

Sufficient illumination is to be provided to reveal corrosion, deformation, fractures, damages or other structural deterioration as well as condition of the coating.

Where soft or semi-hard coatings have been applied, safe access is to be provided for the Surveyor to verify the effec-

tiveness of the coating and to carry out an assessment of the conditions of internal structures which may include spot removal of the coating. When safe access cannot be provided, the soft or semi-hard coating is to be removed.

Casings, ceilings or linings, and loose insulation, where fitted, are to be removed, as required by the Surveyor, for examination of plating and framing. Compositions on plating are to be examined and sounded, but need not be disturbed if found adhering satisfactorily to the plating.

In refrigerated cargo spaces the condition of the coating behind the insulation is to be examined at representative locations. The examination may be limited to verification that the protective coating remains effective and that there are no visible structural defects. Where POOR coating condition is found, the examination is to be extended as deemed necessary by the Surveyor. The condition of the coating is to be reported. If indents, scratches, etc., are detected during surveys of shell plating from the outside, insulations in way are to be removed as required by the Surveyor, for further examination of the plating and adjacent frames.

2.5.3 A communication system is to be arranged between the survey party in the cargo hold, tank or space being examined, the responsible officer on deck and, as the case may be, the navigation bridge. The communication arrangements are to be maintained throughout the survey. This system is also to include the personnel in charge of ballast pump handling if boats or rafts are used.

2.5.4 Explosimeter, oxygen-meter, breathing apparatus, lifelines, riding belts with rope and hook and whistles together with instructions and guidance on their use are to be made available during the survey. A safety check-list is to be provided.

2.5.5 Adequate and safe lighting is to be provided for the safe and efficient conduct of the survey.

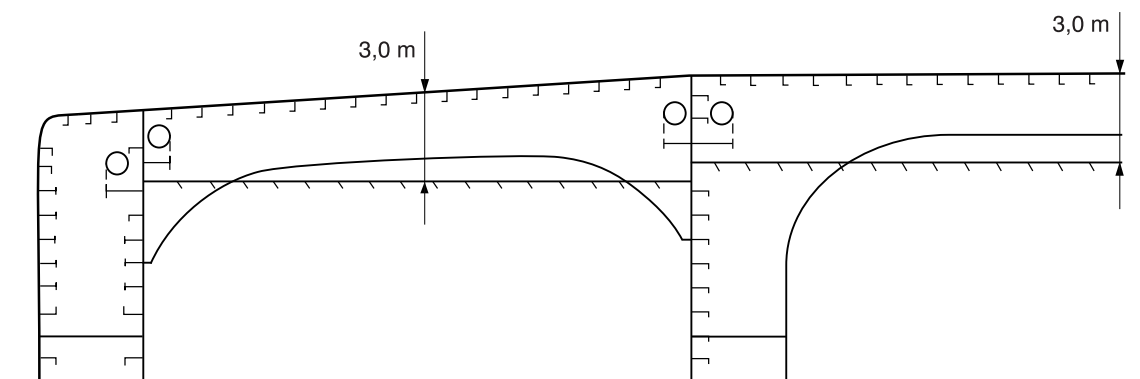
2.5.6 Adequate protective clothing is to be made available and used (e.g. safety helmet, gloves, safety shoes, etc.) during the survey.

2.5.7 Surveys of tanks or applicable holds by means of boats or rafts may only be undertaken with the agreement of the Surveyor, who is to take into account the safety arrangements provided, including weather forecasting and ship response under foreseeable conditions and provided the expected rise of water within the tank does not exceed 0,25m.

2.5.8 When rafts or boats will be used for close-up survey the following conditions are to be observed:

- a) only rough duty, inflatable rafts or boats, having satisfactory residual buoyancy and stability even if one chamber is ruptured, are to be used
- b) the boat or raft is to be tethered to the access ladder and an additional person is to be stationed down the access ladder with a clear view of the boat or raft
- c) appropriate lifejackets are to be available for all participants

Figure 1 : Platform position and ullage corresponding to the maximum water level for oil tankers and chemical tankers



- d) the surface of water in the tank or hold is to be calm (under all foreseeable conditions the expected rise of water within the tank is not to exceed 0,25 m) and the water level stationary. On no account is the level of the water to be rising while the boat or raft is in use
- e) the tank, hold or space must contain clean ballast water only. Even a thin sheen of oil on the water is not acceptable, and
- f) at no time is the water level to be allowed to be within 1 m of the deepest under deck web face flat so that the survey team is not isolated from a direct escape route to the tank hatch. Filling to levels above the deck transverse is only to be contemplated if a deck access manhole is fitted and open in the bay being examined, so that an escape route for the survey party is available at all times. Other effective means of escape to the deck may be considered.
- g) if the tanks (or spaces) are connected by a common venting system, or Inert Gas system, the tank in which the boat or raft is to be used is to be isolated to prevent a transfer of gas from other tanks (or spaces).

2.5.9 Rafts or boats alone may be allowed for inspection of the under deck areas for tanks or spaces, if the depth of the webs is 1,5 m or less.

If the depth of the webs is more than 1,5 m, rafts or boats alone may be allowed only:

- when the coating of the under deck structure is in GOOD condition and there is no evidence of wastage; or
- if a permanent means of access is provided in each bay to allow safe entry and exit. This means:
 - access direct from the deck via a vertical ladder and a small platform fitted approximately 2 m below the deck in each bay; or
 - access to deck from a longitudinal permanent platform having ladders to deck in each end of the tank. The platform shall, for the full length of the tank, be arranged in level with, or above, the maximum water level needed for rafting of under deck structure. For this purpose, the ullage corresponding to the maximum water level is to be assumed not more than 3 m from the deck plate measured at the mid-span of deck transverse and in the middle length of the tank (see Fig 1).

If neither of the above conditions are met, then staging or an other equivalent means is to be provided for the survey of the under deck areas.

The use of rafts or boats as mentioned above does not preclude the use of boats or rafts to move about within a tank during a survey.

2.5.10 When examination of associated structure is required, the following applies:

- ceilings in holds and floors in the engine room are to be lifted to the necessary extent for examination of the structure
- cement or other protective sheathing is to be removed when there is any doubt as to the condition of the plating underneath or when adherence to plating is not tight
- in the case of solid ballast spaces, the solid ballast is to be partially removed for examination of the condition of the structure in way. Should doubts arise, the Surveyor may require more extensive removal of the solid ballast
- insulation of compartments intended for refrigerated cargoes is to be removed over the necessary extent for examination by the Surveyor of the condition of the structure, unless constructional arrangements make such inspections possible without removing the insulation.

2.6 Access to structures

2.6.1 For overall survey, means are to be provided to enable the Surveyor to examine the hull structure in a safe and practical way.

2.6.2 For survey in cargo holds and ballast tanks, one or more of the following means for access, acceptable to the Surveyor, is to be provided:

- permanent staging and passages through structures
- temporary staging and passages through structures
- hydraulic arm vehicles such as conventional cherry pickers, lifts and movable platforms
- boats or rafts
- other equivalent means.

2.6.3 For surveys conducted by use of a remote inspection technique, one or more of the following means of access, acceptable to the Surveyor, is to be provided:

- unmanned robot arm

- remotely operated vehicles (ROV)
- unmanned aerial vehicles/drones
- other means acceptable to the Society.

Note 1: Use of RIT as an alternative to close-up survey is not allowed for ships assigned with the service notation **bulk carrier ESP** or **bulk carrier BC-A ESP** or **bulk carrier BC-B ESP** or **bulk carrier BC-C ESP** or **self-unloading bulk carrier ESP** or **ore carrier ESP** or **combination carrier/OBO ESP** or **combination carrier/OOC ESP** or **oil tanker ESP**.

2.7 Equipment for surveys

2.7.1 One or more of the following fracture detection procedures may be required if deemed necessary by the Surveyor:

- radiographic equipment
- ultrasonic equipment
- magnetic particle equipment
- dye penetrant.

2.8 Rescue and emergency response equipment

2.8.1 If breathing apparatus and/or other equipment is used as 'Rescue and emergency response equipment' then it is recommended that the equipment should be suitable for the configuration of the space being surveyed.

2.9 Surveys at sea and anchorage

2.9.1 Surveys at sea or at anchorage may be accepted provided the Surveyor is given the necessary assistance by the personnel on board. Precautions and procedures for carrying out the survey are to be in accordance with [2.5] to [2.7].

2.10 Repairs and maintenance during voyage

2.10.1 Where repairs to hull, machinery or other equipment, which affect or may affect the class, are to be carried out by a riding crew during a voyage, they are to be planned in advance. A complete repair procedure including the extent of proposed repair and the need for the Surveyor's attendance during the voyage is to be submitted to the Society for approval sufficiently in advance. Failure to notify the Society in advance of the repairs may result in the suspension of class of the ship.

Where in any emergency circumstance, emergency repairs are to be effected immediately, the repairs should be documented in the ship's log and submitted thereafter to the Society for use in determining further survey requirements.

2.10.2 The above is not intended to include maintenance to and overhaul of the hull, machinery and equipment in accordance with the Manufacturer's recommended procedures and established marine practice, which does not require the Society's agreement. However, any repair resulting from such maintenance and overhauls which affects or may affect the class is to be noted in the ship's log and submitted to the attending Surveyor for use in determining further survey requirements.

2.11 Repairs

2.11.1 Any damage in association with wastage over the allowable limits (including buckling, grooving, detachment or fracture), or extensive areas of wastage over the allowable limits, which affects or, in the opinion of the Surveyor, will affect the ship's structural, watertight or weathertight integrity, is to be promptly and thoroughly (see [2.2.17]) repaired. Areas to be considered include, as applicable for the different ship types:

- side structure and side plating; side shell frames, their end attachments and adjacent shell plating; inner side structure and inner side plating
- deck structure and deck plating
- bottom structure and bottom plating; inner bottom structure and inner bottom plating
- longitudinal bulkheads structure and longitudinal bulkheads plating, where fitted
- watertight or oiltight bulkheads structure and plating
- hatch covers or hatch coamings, where fitted
- weld connection between air pipes and deck plating
- air pipe heads installed on the exposed decks
- ventilators, including closing devices, if any; bunker and vent piping systems.

2.11.2 For locations where adequate repair facilities are not available, consideration may be given to allow the ship to proceed directly to a repair facility. This may require discharging the cargo and/or temporary repairs for the intended voyage.

2.11.3 Additionally, when a survey results in the identification of structural defects or corrosion, either of which, in the opinion of the Surveyor, will impair the vessel's fitness for continued service, remedial measures are to be implemented before the ship continues in service.

2.11.4 Where the damage found on structure mentioned in [2.11.1] is isolated and of a localised nature which does not affect the ship's structural integrity, consideration may be given by the Surveyor to allow an appropriate temporary repair to restore watertight or weathertight integrity and impose a condition of class in accordance with the Rules, with a specific time limit.

2.12 Remote Inspection Techniques (RIT)

2.12.1 The RIT is to provide the information normally obtained from a close-up survey (except on ESP ships). RIT surveys are to be carried out in accordance with the requirements given here-in and the requirements of IACS Recommendation 42, "Guidelines for use of remote inspection techniques for surveys". These considerations are to be included in the proposals for use of a RIT which are to be submitted in advance of the survey so that satisfactory arrangements can be agreed with the Society.

Note 1: Use of RIT as an alternative to close-up survey is not allowed for ships assigned with the service notation **bulk carrier ESP** or **bulk carrier BC-A ESP** or **bulk carrier BC-B ESP** or **bulk carrier BC-C ESP** or **self-unloading bulk carrier ESP** or **ore carrier ESP** or **combination carrier/OBO ESP** or **combination carrier/OOC ESP** or **oil tanker ESP**.

2.12.2 The equipment and procedure for observing and reporting the survey using a RIT are to be discussed and agreed with the parties involved prior to the RIT survey, and suitable time is to be allowed to set-up, calibrate and test all equipment beforehand.

2.12.3 When using a RIT as an alternative to close-up survey, if not carried out by the Society itself, it is to be conducted by a firm approved as a service supplier and is to be witnessed by an attending Surveyor of the Society.

Note 1: NR533, Approval of Service Suppliers, gives details about the certification.

2.12.4 The structure to be examined using a RIT is to be sufficiently clean to permit meaningful examination. Visibility is to be sufficient to allow for a meaningful examination. The Society is to be satisfied with the methods of orientation on the structure.

2.12.5 The Surveyor is to be satisfied with the method of data presentation including pictorial representation, and a good two-way communication between the Surveyor and RIT operator is to be provided.

2.12.6 If the RIT reveals damage or deterioration that requires attention, the Surveyor may require traditional survey to be undertaken without the use of a RIT.

3 Certificate of Classification: issue, validity, endorsement and renewal

3.1 Issue of Certificate of Classification

3.1.1 A Certificate of Classification, bearing the class notations assigned to the ship and an expiry date, is issued to any classed ship.

3.1.2 A Provisional Certificate of Classification may serve as a Certificate of Classification in some cases, such as after an admission to class survey, after a class renewal survey, or when the Society deems it necessary.

The period of validity for the Provisional Certificate of Classification is not to exceed 6 months from the date of issuance.

3.1.3 The Certificate of Classification is to be made available to the Society's Surveyors upon request.

3.2 Validity of Certificate of Classification, maintenance of class

3.2.1 According to Ch 1, Sec 1, [2.4], the Society alone is qualified to confirm the class of the ship and the validity of its Certificate of Classification.

3.2.2 During the class period, a Certificate of Classification is valid when it is not expired.

The class is maintained during a certain period or at a given date, when during the said period or at such date the conditions for suspension or withdrawal of class are not met.

Refer also to Ch 1, Sec 1, [1.3.4].

3.2.3 At the request of the Owner, a statement confirming the maintenance of class may be issued by the Society based on the information in its records for that ship at the time.

This statement is issued on the assumption that the Owner has complied with the Rules, in particular with [6].

Should any information which would have prevented the Society from issuing the statement and which was not available at the time subsequently come to light, the statement may be cancelled.

Attention is drawn to Ch 2, Sec 3, [1.2], whereby the Society, upon becoming aware of a breach of the Rules, is empowered to suspend class from the date of the breach, which may be prior to the date of the statement.

3.2.4 According to the same conditions as in [3.2.3], a statement declaring that the class is maintained "clean and free from condition of class" may be issued by the Society when there is no pending condition of class at that date.

3.2.5 Classification-related documents and information are liable to be invalidated by the Society whenever their object is found to differ from that on which they were based or to be contrary to the applicable requirements. The Owner is liable for any damage which may be caused to any third party from improper use of such documents and information.

3.3 Endorsement of Certificate of Classification

3.3.1 Text of endorsement

When surveys are satisfactorily carried out, the Certificate of Classification is generally endorsed accordingly, with the relevant entries.

3.3.2 Possible modifications to endorsements

The Society reserves the right to modify the endorsements made by Surveyors.

3.4 Status of surveys and conditions of class

3.4.1 Information given in the Certificate of Classification, ship survey status, Rules and other ship specific documents made available to the Owner, enables the Owner to identify the status of surveys and conditions of class.

3.4.2 The omission of such information does not absolve the Owner from ensuring that surveys are held by the limit dates and pending conditions of class are cleared to avoid any inconvenience which is liable to result from the suspension or withdrawal of class; see Ch 2, Sec 3.

4 Class renewal survey

4.1 General principles

4.1.1 Class renewal surveys are to be carried out at five-year (class symbol **I**) or three-year (class symbol **II**) intervals. However, consideration may be given by the Society to granting an extension for a maximum of three months after the limit date, in exceptional circumstances. In such cases the next period of class will start from the limit date for the previous class renewal survey before the extension was granted.

4.1.2 For surveys completed within three months before the limit date of the class renewal survey, the next period of class will start from this limit date. For surveys completed more than three months before the limit date, the period of class will start from the survey completion date.

In cases where the vessel has been laid up or has been out of service for a considerable period because of a major repair or modification and the Owner elects to carry out only the overdue surveys, the next period of class will start from the expiry date of the renewal survey. If the Owner elects to carry out the next due renewal survey, the period of class will start from the survey completion date.

4.1.3 A new period of class is assigned to the ship after the satisfactory completion of the class renewal survey, and a new Certificate of Classification is issued for the new period of class.

4.1.4 Concurrent crediting to both Intermediate Survey and Class Renewal Survey for surveys and thickness measurements of spaces are not acceptable.

4.2 Normal survey system (SS)

4.2.1 When the normal survey system is applied to ships with a 5 years period of class, the class renewal survey may be commenced at the fourth annual survey and continued during the following year with a view to completion by its due date. In this case the survey may be carried out by partial surveys at different times. The number of checks to be performed at each partial survey and the interval between partial surveys are to be agreed by the Society.

4.2.2 A class renewal survey may be commenced before the fourth annual survey at the request of the Owner. In this case, the survey is to be completed within fifteen months. The conditions for the execution of partial surveys are the same as those referred to in [4.2.1].

4.3 Continuous survey system (CS)

4.3.1 The request by the Owner for admission to the continuous survey system will be considered by the Society and agreement depends on the type and age of hull and machinery. This system may apply to the class renewal survey of hull (CSH), machinery (CSM) or other installations such as refrigerating installations (CSR) covered by an additional class notation.

4.3.2 The continuous survey system is not applicable to the class renewal survey of the hull of those ships subject to the Enhanced Survey Program (ESP), i.e. ships with the service notation **oil tanker**, **combination carrier**, **bulk carrier**, **ore carrier** or **chemical tanker**, nor to ships subject to the requirements of Ch 4, Sec 7, nor to ships with the class symbol **II**.

4.3.3 For ships other than those referred to in [4.3.2], the continuous survey system is not applicable to the class renewal survey of the hull of ships over 20 years old. However, consideration may be given, at the discretion of the Society, to the applicability of the continuous survey system to the class renewal survey of the hull of ships over 20 years old.

4.3.4 When the continuous survey system is applied, appropriate notations as indicated in [4.3.1] are entered in the Register of Ships.

4.3.5 Ships subject to the continuous survey system are provided with lists of items to be surveyed under this system.

4.3.6 For items surveyed under the continuous survey system, the following requirements generally apply:

- a) the interval between two consecutive surveys of each item is not to exceed five years
- b) the items are to be surveyed in rotation, so far as practicable ensuring that approximately equivalent portions are examined each year
- c) the Society may credit for continuous survey results of surveys carried out before the admission to the continuous survey scheme
- d) each item is to be surveyed at one time, as far as practicable; the Society may, however, allow possible repair work to be carried out within a certain period.
- e) main or auxiliary engine crankshaft journal and associated bearings may be surveyed within intervals specified in item a) or in accordance with engine manufacturers recommended replacement schedule subject to satisfactory verification of survey items listed in item f)
- f) The Surveyor shall check within the 5 year CSM cycle:
 - at least 1 crank journal bearing for medium and high speed engines (> 300 rpm), with the selected bearing to be presented for survey chosen from 1 of the 3 aftermost bearings and alternate to the last CSM cycle
 - at least 2 crank journal bearings for slow speed engines (< 300 rpm), with the selected bearings to be presented for survey chosen from 1 of the 3 aftermost bearings (alternate to last CSM cycle) and the highest loaded bearing as determined by the engine manufacturer.

The remainder of the bearings may be permitted for verification by C/E followed by confirmatory surveys, i.e. checking bearing clearances, oil analysis, photos of non-invasive bearing and bearing edge checks performed, crankcase inspection and verification of deflections.

4.3.7 For ships more than ten years of age, the ballast tanks are to be internally examined twice in each five-year class period, i.e. once within the scope of the intermediate survey and once within the scope of the continuous survey system for the class renewal survey.

4.3.8 For ships under continuous survey, items not included in the continuous survey cycle are to be inspected according to the provisions given in [4.2]. Bottom surveys are to be carried out according to the requirements of [5.4]. In addition, the bottom survey which is to be carried out in conjunction with the end of class period is to be performed within 15 months before the end of this class period.

4.3.9 Upon application by the Owner, the Society may agree, subject to certain conditions, that some items of machinery which are included in the continuous survey cycle are examined by the Chief Engineer where the Society is not represented. The Chief Engineer's inspection is to be

followed by a confirmatory survey carried out by a Surveyor. The conditions for the application of this procedure are given in Ch 2, App 2.

4.3.10 The continuous survey system does not supersede the annual surveys and other periodical and occasional surveys.

4.3.11 A general examination of the ship, as detailed in Ch 3, Sec 1 for annual surveys, is to be carried out at the end of the period of class.

4.3.12 For laid-up ships, specific requirements given in [8.1] apply.

4.3.13 The continuous survey system may be discontinued at any time at the discretion of the Society, or at the request of the Owner, and a specific arrangement devised.

4.4 Planned maintenance survey system for machinery (PMS)

4.4.1 A planned maintenance survey system may be considered as an alternative to the continuous survey system for machinery and is limited to components and systems covered by it. When such a system is implemented, a survey system other than those normally adopted and with intervals different from those of the continuous survey system as detailed in [4.3] may be accepted.

4.4.2 The conditions for review of the planned maintenance survey system, the determination of survey item intervals and the general scope of surveys are detailed in Ch 2, App 1.

4.4.3 The conditions related to Chief Engineer's inspections within the scope of PMS are given in Ch 2, App 2.

4.4.4 The planned maintenance survey system does not supersede the annual surveys and other periodical and occasional surveys.

4.4.5 A general examination of the machinery, as detailed in Ch 3, Sec 1 for annual surveys, is to be carried out.

4.4.6 The planned maintenance survey system may be discontinued at any time at the discretion of the Society, or at the request of the Owner, and a specific arrangement devised.

4.4.7 Surveys of machinery may be carried out on a condition based maintenance (CBM) scheme basis on vessels operating on approved PMS survey system.

4.4.8 The conditions for approval of the condition monitoring and condition based maintenance survey schemes and the general scope of surveys are detailed in Ch 2, App 4.

5 Other periodical surveys

5.1 General

5.1.1 The different types of periodical surveys are summarised in Tab 1.

5.2 Annual surveys

5.2.1 Annual surveys are to be carried out within three months before or after each anniversary date.

5.3 Intermediate surveys

5.3.1 An intermediate survey, where applicable, is to be carried out within the window from three months before the second to three months after the third anniversary date.

5.3.2 The intermediate survey is applicable at any period of class to ships with the following service notations:

- **oil tanker, chemical tanker, FLS tanker, liquefied gas carrier, combination carrier/OBO, combination carrier/OOC**
- **yacht** of less than 24 meters in length, as defined in NR500, Rules for the Classification and Certification of Yachts.

5.3.3 The intermediate survey is applicable at any period of class to ships other than those indicated in [5.3.2] which are five years old and over.

5.3.4 The intermediate survey is not applicable to ships with class symbol **II**.

5.3.5 Concurrent crediting to both Intermediate Survey and Class Renewal Survey for surveys and thickness measurements of spaces are not acceptable.

5.4 Bottom survey

5.4.1 Bottom survey means the examination of the outside of the ship's bottom and related items. This examination may be carried out with the ship either in dry dock (or on a slipway) or afloat: in the former case the survey will be referred to as dry-docking survey, while in the latter case as in-water survey.

5.4.2 The Owner is to notify the Society whenever the outside of the ship's bottom and related items can be examined in dry dock or on a slipway.

5.4.3 For ships classed with the class symbol **I**, there are to be two examinations of the outside of the ship's bottom and related items in each period of class of five years

In all cases, the interval between any two such examinations is not to exceed 36 months.

Note 1: Compliance with the above does not absolve the Owner from compliance with the requirements of SOLAS as amended, especially when shorter intervals between examination of the ship's bottom for certain types of ships are required. Attention is also drawn to the relevant requirements of Ch 1, Sec 1, [3.1], concerning application of national and international regulations.

An extension of examination of the ship's bottom of three months beyond the due date can be granted in exceptional circumstances, as defined in [2.1.7].

5.4.4 For ships under the normal survey system (SS), one of the bottom surveys to be performed in each period of class is to be carried out in conjunction with the class renewal survey and is to be a dry-docking survey.

The Society may allow the bottom survey carried out between class renewal surveys to be replaced by an in-water survey, subject to the provisions of Ch 3, Sec 4. Special consideration is to be given to ships of 15 years of age and over before being permitted to have such in-water examinations.

For ships with additional service feature **ESP** and over 15 years of age, it is however reminded that a bottom survey in dry dock is to be carried out concurrently with the intermediate survey.

5.4.5 For ships under the continuous survey system of hull (CSH), one of the bottom surveys to be performed in each period of class is to be carried out in conjunction with the end of class period.

This bottom survey may be an in-water survey, subject to the provisions of Ch 3, Sec 4 and provided that the previous bottom survey performed in the period of class was a dry-docking survey. Special consideration is to be given to ships of 15 years of age and over before being permitted to have such in-water examinations.

5.4.6 Ships with service notation **HSC, HSC-CAT A, HSC-CAT B** are to be submitted to a bottom survey in dry condition at each annual survey and each class renewal survey.

5.4.7 The interval between examinations of the outside of the ship's bottom and related items for ships operating in fresh water and for certain harbour or non-self-propelled craft may be greater than that given above, as approved by the Society.

5.5 Tailshaft survey

5.5.1 Definition

Tailshaft survey means survey of propeller shafts and tube shafts (hereafter referred to as tailshafts) as well as survey of other propulsion systems.

5.5.2 Tailshaft complete survey

Tailshafts are to be submitted to complete examination at the periodicity specified below and summarised in Fig 2, based on the type of shaft and its design.

a) Where the tailshaft is fitted with continuous liners, or approved oil sealing glands, or made of corrosion-resistant material, the periodicity of complete surveys is:

- 3 years for single shafting arrangements
- 4 years for multi-shafting arrangements.

b) These periodicities may be increased to 5 years in the following cases:

- where the propeller is fitted keyless to the shaft taper, the shaft is protected from sea water, the design details are approved, and a non-destructive examination of the forward part of the aft shaft taper is performed at each survey by an approved crack-detection method

- where the propeller is fitted to a keyed shaft taper the design details of which comply with the applicable requirements in Pt C, Ch 1, Sec 7, and a non-destructive examination of the after end of the cylindrical part of the shaft (from the after end of the liner, if any), and of about one third of the length of the taper from the large end is performed at each survey by an approved crack-detection method
- where the propeller is fitted to a solid flange coupling at the aft end of the shaft, the shaft and its fittings are not exposed to corrosion, the design details are approved. Non-destructive examination of the fillet radius of the aft propeller shaft flange may be required if the visual examination of the area is not satisfactory.

c) In all other cases the periodicity of complete surveys is two years and six months (2,5 years).

5.5.3 Tailshaft modified survey

A modified survey of the tailshaft is an alternate way of examination the scope of which is given in Ch 3, Sec 5. It may be accepted for tailshafts described in [5.5.2] and for water lubricated tailshafts, provided that the design criteria for **MON-SHAFT** notation as per Pt F, Ch 5, Sec 2, [3] are fulfilled and that, accordingly:

- For ships fitted with oil lubricated tailshaft bearings:
 - the tailshafts are fitted with approved oil sealing glands
 - the shaft and its fittings are not exposed to corrosion
 - the design details are approved
 - the clearances of the aft bearing are found to be within acceptable limits
 - the oil and the oil sealing arrangements prove effective
 - lubricating oil analyses are carried out regularly at intervals not exceeding six months and oil consumption is recorded at the same intervals.
- For ships fitted with water lubricated tailshaft bearings:
 - the clearances of the aft bearing are found to be within acceptable limits
 - the results of the endoscopic examination are found satisfactory

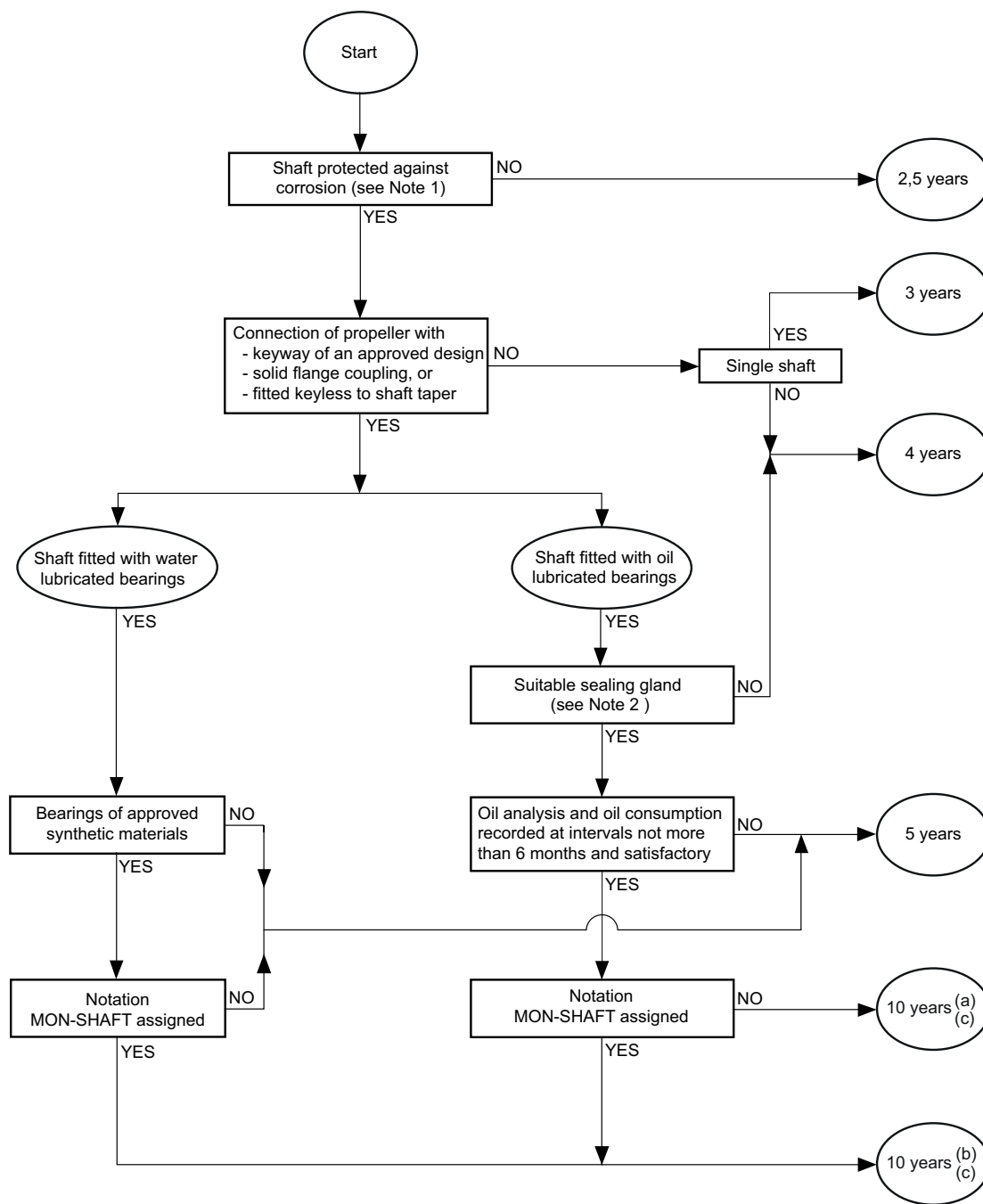
Note 1: The purpose of the endoscopic examination is to check visually the condition of the shaft in particular in way of bearings and at junction with sleeves (where provided)

 - in case of forced lubrication system, satisfactory operation of water pumping and filtering system has been checked
 - if applicable, water analyses have been carried out and recorded, at regular intervals not exceeding six months.

The modified survey is to be carried out five years after the last complete survey, with a window period of plus or minus six months.

The next complete survey is to be carried out ten years after the last complete survey.

Figure 2 : Periodicity of complete survey of tailshaft

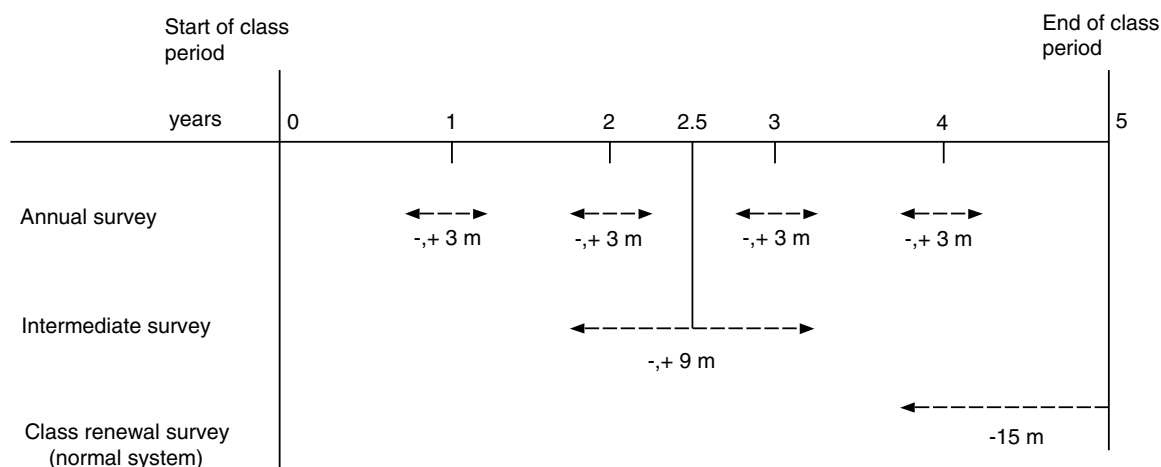


(a) : with shaft withdrawn, subject to modified survey at 5 years plus or minus 6 months
 (b) : with shaft in place, subject to modified survey at 5 years plus or minus 6 months
 (c) : the periodicity cannot exceed the maximum recommended by the designer and manufacturer of the tailshaft and bearing system.

Note 1: Shafts protected against corrosion are those:

- made of corrosion resistant material, or
- fitted with continuous liners or systems considered as equivalent, or
- fitted with oil lubricated bearings and oil sealing glands.

Note 2: Suitable sealing glands are glands which are type-approved by the Society with regard to protection of the sterntube against ingress of water.

Figure 3 : Links between anniversary dates and annual, intermediate and class renewal surveys

5.5.4 Survey of propeller shafts and tube shafts - Applicable requirements from 1 January 2016

Reference is to be made to Ch 3, Sec 5, [3] for revised requirements applicable to all ships with conventional shafting fitted with a propeller, unless alternative means are provided to assure the condition of the propeller shaft assembly.

Such requirements are applicable:

- from 1 January 2016, for ships delivered on or after 1 January 2016
- after the first shaft survey scheduled on or after 1 January 2016, for ships delivered before 1 January 2016.

5.5.5 Other propulsion systems

Driving components serving the same purpose as the tail-shaft in other propulsion systems, such as directional propellers, vertical axis propellers, water jet units, dynamic positioning systems and thruster assisted mooring systems, are to be submitted to periodical surveys at intervals not exceeding five years.

5.5.6 Pod propulsion systems

Shafting system (including tightness system and connection of the propeller to the shaft) of pod propulsion systems are to be submitted to complete or modified surveys, the periodicity of which is determined in the same principle as for tailshafts described in [5.5.2], [5.5.3] and Fig 2.

Propulsion motors, orientating devices and other arrangement, are to be surveyed at each class renewal survey, see Ch 3, Sec 3, [3.2.7].

5.6 Boiler survey

5.6.1 There are to be two internal examinations of boilers in each period of class of five years.

In all cases, the interval between any two such examinations is not to exceed 36 months.

5.6.2 The internal examination of thermal oil heaters is to be carried out at maximum intervals of 5 years.

5.6.3 An extension of examination of the boiler up to three months beyond the due date can be granted in exceptional circumstances, as defined in [2.1.7]. The extension may be granted by the Society after the following is satisfactorily carried out:

- external examination of the boiler
- examination and operational test of boiler safety valve relieving gear (easing gear)
- operational test of boiler protective devices
- review of the following records since the last boiler survey: operation, maintenance, repair history, feedwater chemistry.

5.6.4 Boilers are also submitted to an external examination as a part of the annual survey of machinery.

5.7 Links between anniversary dates and annual surveys, intermediate surveys and class renewal surveys

5.7.1 The link between the anniversary dates, the class renewal survey (when carried out according to the normal system), and the annual and intermediate surveys is given in Fig 3.

6 Occasional surveys

6.1 General

6.1.1 An occasional survey is any survey which is not a periodical survey. The survey may be defined as an occasional survey of hull, machinery, boilers, refrigerating plants, etc., depending on the part of the ship concerned.

Where defects are found, the Surveyor may extend the scope of the survey as deemed necessary.

6.1.2 Occasional surveys are carried out at the time of, for example:

- updating of classification documents (e.g. change of the Owner, name of the ship, flag)
- damage or suspected damage
- repair or renewal work
- Port State Control inspections
- alterations or conversion
- quality system audits
- postponement of surveys or conditions of class.

6.2 Damage and repair surveys

6.2.1 In the event of damage which affects or may affect the class of the ship, the Owner is to apply to the Society for a survey. Such application is to be made as soon as possible to enable the Surveyor to ascertain the extent of the damage and necessary repairs, if any.

Note 1: Whenever a ship is fitted with an helicopter platform which is made in aluminium or other low melting metal construction which is not made equivalent to steel, and a fire occurred on the said platform or in close proximity, the platform is to be subject to a structural survey to determine its suitability for further use.

6.2.2 If, after sustaining damage, the ship calls at a port where the Society is not represented, the Owner is to notify the Society forthwith, supply all available information regarding the damage and make arrangements for the ship to be surveyed in the nearest port where the Society is represented.

6.2.3 All repairs to hull, machinery and equipment which may be required in order for a ship to retain its class are to be to the satisfaction of the Surveyor.

During repairs or maintenance work, the Owner is to arrange so that any damage, defects or non-compliance with the rule requirements are reported to the Surveyor during his survey.

6.2.4 Damages and partial or temporary repairs considered acceptable by the Surveyor for a limited period of time are the subject of an appropriate condition of class.

6.2.5 Damages or repairs required by the Surveyor to be re-examined after a certain period of time are the subject of an appropriate condition of class.

6.3 Port State Control survey

6.3.1 An occasional survey is to be requested by the Owner wherever a ship is detained as a result of a Port State Control inspection, as described in Ch 1, Sec 1, [3.4].

6.4 Conversions, alterations and repairs

6.4.1 Conversions, alterations or repairs of/to structures and arrangements affecting the class are to be carried out in accordance with the requirements of the Society and to its satisfaction. Where necessary, documentation is to be submitted to the Society and/or made available to the attending Surveyor.

6.4.2 Materials and equipment used for conversions, alterations or repairs are generally to meet the requirements of the Rules for new ships built under survey; see Ch 2, Sec 1, [2.1.5].

6.5 Quality System audits

6.5.1 The Society reserves the right to carry out occasional surveys in order to conduct audits either as deemed necessary in pursuance of its internal Quality System or as required by external organisations (e.g. IACS, flag Administrations).

6.5.2 These surveys may also be attended by auditors external to the Society.

6.5.3 The scope of these surveys is determined by the Society.

6.6 Unscheduled surveys

6.6.1 The Society reserves the right to carry out unscheduled surveys as deemed necessary and whose scope is determined by the Society, based on PSC (Port State Control) history of the ship.

7 Change of ownership

7.1

7.1.1 In the case of change of ownership, the ship retains its current class with the Society provided that:

- the Society is informed of the change sufficiently in advance to carry out any specific survey required by the Owner in view of the sale; refer to [1.1.1], and
- the new Owner signs the appropriate request, involving acceptance of the Society's general conditions and Rules. This request covers inter alia the condition of the ship when changing ownership.

Note 1: The ship's class is maintained without prejudice to those provisions in the Rules which are to be enforced in cases likely to cause suspension or withdrawal of the class such as particular damages or repairs to the ship of which the Society has not been advised by the former or, as the case may be, new Owner.

Note 2: No information whatsoever related to the class of the ship will be provided or confirmed to any third party, unless the appropriate request for information is duly completed and signed by the party making the request and the authorisation of the current Owner is obtained.

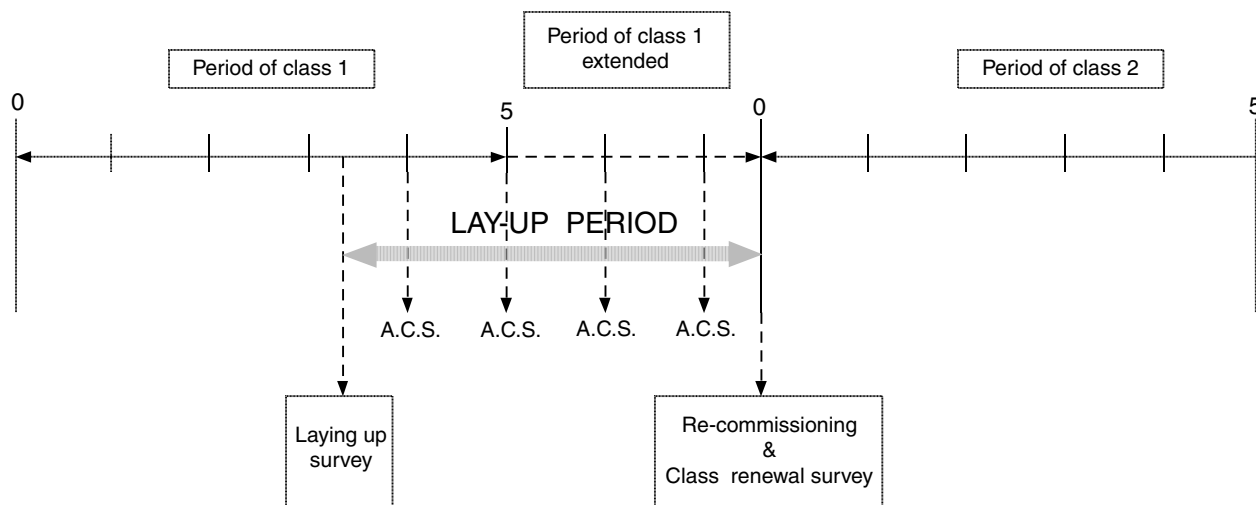
8 Lay-up and re-commissioning

8.1 General principles

8.1.1 A ship put out of commission may be subject to specific requirements for maintenance of class, as specified below, provided that the Owner notifies the Society of the fact.

If the Owner does not notify the Society of the laying-up of the ship or does not implement the lay-up maintenance program, the ship's class may be suspended and/or withdrawn when the due surveys are not carried out by their limit dates in accordance with the applicable requirements given in Ch 2, Sec 3.

Figure 4 : Survey scheme of a case of a lay-up going beyond the expiry date of the period of class



Note 1: A. C. S. means annual lay-up condition survey.

8.1.2 The lay-up maintenance program provides for a “laying-up survey” to be performed at the beginning of lay-up and subsequent “annual lay-up condition surveys” to be performed in lieu of the normal annual surveys which are no longer required to be carried out as long as the ship remains laid-up. The minimum content of the lay-up maintenance program as well as the scope of these surveys are given in Ch 3, App 1. The other periodical surveys which become overdue during the lay-up period may be postponed until the re-commissioning of the ship.

8.1.3 Where the ship has an approved lay-up maintenance program and its period of class expires, the period of class is extended until it is re-commissioned, subject to the satisfactory completion of the annual lay-up condition surveys as described in [8.1.2].

8.1.4 The periodical surveys carried out during the lay-up period may be credited, either wholly or in part, at the discretion of the Society, having particular regard to their extent and dates. These surveys will be taken into account for the determination of the extent of surveys required for the re-commissioning of the ship and/or the expiry dates of the next periodical surveys of the same type.

8.1.5 When a ship is re-commissioned, the Owner is to notify the Society and make provisions for the ship to be submitted to the following surveys:

- an occasional survey prior to re-commissioning, the scope of which depends on the duration of the lay-up period

- all periodical surveys which have been postponed in accordance with [8.1.2], taking into account the provisions of [8.1.4].

8.1.6 Where the previous period of class expired before the re-commissioning and was extended as stated in [8.1.3], in addition to the provisions of [8.1.5] a complete class renewal survey is to be carried out prior to re-commissioning. Those items which have been surveyed in compliance with the class renewal survey requirements during the 15 months preceding the re-commissioning may be credited. A new period of class is assigned from the completion of this class renewal survey.

8.1.7 The principles of intervals or limit dates for surveys to be carried out during the lay-up period, as stated in [8.1.1] to [8.1.6], are summarised in Fig 4.

8.1.8 The scope of the laying-up survey and annual lay-up condition surveys are described in detail in Ch 3, App 1.

9 Safety Management System

9.1

9.1.1 For all ships to which the ISM Code applies, the Society may have to report possible safety management system shortcomings, on the occasion of the Annual Survey or Intermediate Survey or Class Renewal Survey or Occasional Surveys or Statutory Surveys, to the Organisation that has issued the Safety Management Certificate.

SECTION 3

SUSPENSION AND WITHDRAWAL OF CLASS

1 General

1.1 Discontinuance of class

1.1.1 The class may be discontinued either temporarily or permanently. In the former case it is referred to as “suspension” of class, in the latter case as “withdrawal” of class. In both these cases, the class is invalidated in all respects. In the case of withdrawal, the name of the ship is deleted from the Register of Ships. The current version of the Register can be consulted on the Society website.

1.2 Suspension of class

1.2.1 The class may be suspended either automatically or following the decision of the Society. In any event, the ship will be considered as not retaining its class from the date of suspension until the date when class is reinstated.

1.2.2 The class may be automatically suspended when one or more of the following circumstances occur:

- when a ship is not operated in compliance with the rule requirements, such as in cases of services or conditions not covered by the service notation, or trade outside the navigation restrictions for which the class was assigned
- when a ship proceeds to sea with less freeboard than that assigned, or has the freeboard marks placed on the sides in a position higher than that assigned, or, in cases of ships where freeboards are not assigned, the draught is greater than that assigned
- when the Owner fails to inform the Society in order to submit the ship to a survey after defects or damages affecting the class have been detected
- when repairs, alterations or conversions affecting the class are carried out either without requesting the attendance of the Society or not to the satisfaction of the Surveyor. For voyage repairs, reference is to be made to Ch 2, Sec 2, [2.10].

Suspension of class with respect to the above cases will remain in effect until such time as the cause giving rise to suspension has been removed. Moreover, the Society may require any additional surveys deemed necessary taking into account the condition of the ship and the cause of the suspension.

1.2.3 In addition, the class is automatically suspended:

- when the class renewal survey has not been completed by its limit date or within the time granted for the completion of the survey, unless the ship is under attendance by the Society’s Surveyors with a view to completion prior to resuming trading

- when the annual or intermediate surveys have not been completed by the end of the corresponding survey time window (see Ch 2, Sec 2, [2.1.3]) unless the ship is under attendance for completion of the survey.

Continuous survey item(s) due or overdue at the time of annual surveys is (are) to be dealt with. The ship’s class will be subject to a suspension procedure if the item(s) is (are) not surveyed or postponed by agreement with the Society.

Suspension of class with respect to the above cases will remain in effect until such time as the class is reinstated once the due items and/or surveys have been dealt with.

1.2.4 In addition to the circumstances for which automatic suspension may apply, the class of a ship may also be suspended following the decision of the Society:

- when a condition of class is not dealt with within the time limit specified, unless it is postponed before the limit date by agreement with the Society
- when one or more surveys are not held by their limit dates (see Ch 2, Sec 2, [2.1.4]) or the dates stipulated by the Society also taking into account any extensions granted in accordance with the provisions of Part A
- when, due to reported defects, the Society considers that a ship is not entitled to retain its class even on a temporary basis (pending necessary repairs or renewals, etc.)
- when the ship has not been maintained in proper condition, as set forth in Ch 1, Sec 1, [3.3.2]
- in other circumstances which the Society will consider on their merits (e.g. in the event of non-payment of fees or where the Owner fails to render the ship available for the occasional surveys as listed in Ch 2, Sec 2, [6.1.2]).

Suspension of class decided by the Society takes effect from the date when the conditions for suspension of class are met and will remain in effect until such time as the class is reinstated once the due items and/or surveys have been dealt with.

1.3 Withdrawal of class

1.3.1 The Society will withdraw the class of a ship in the following cases:

- at the request of the Owner
- as a rule, when the causes that have given rise to a suspension currently in effect have not been removed within six months after due notification of suspension to the Owner
- when the ship is reported as a constructive total loss
- when the ship is lost
- when the ship is reported scrapped.

Withdrawal of class may take effect from the date on which the circumstances causing such withdrawal occur.

The contract for the classification of the ship is terminated as of right in the above cases.

The class is also withdrawn according to the provisions of article 9 of the Marine & Offshore General Conditions in case of contract termination.

1.3.2 When the withdrawal of class of a ship comes into effect, the Society will:

- forward the Owner written notice
- delete the ship from the Register of Ships
- notify the flag Administration
- make the information available to the Underwriters, at their request.

1.4 Suspension/withdrawal of additional class notations

1.4.1 If the survey requirements related to maintenance of additional class notations are not complied with, the suspension or withdrawal may be limited to the notations concerned.

The same procedure may apply to service notations of ships which are assigned with more than one service notation.

1.4.2 The suspension or withdrawal of an additional class notation or a service notation (where a ship is assigned with more than one service notation) generally does not affect the class.

APPENDIX 1

PLANNED MAINTENANCE SURVEY SYSTEM

1 General

1.1

1.1.1 A Planned Maintenance Survey system (hereafter referred to as PMS) is a survey system for machinery items which may be considered as an alternative to the Continuous Survey for Machinery system (hereafter referred to as CSM), as described in Ch 2, Sec 2, [4.4].

1.1.2 This survey scheme is to be approved by the Society before being implemented. When the PMS system is applied, the scope and periodicity of the class renewal survey are tailored for each individual item of machinery and determined on the basis of recommended overhauls stipulated by the manufacturers, documented experience of the operators and, where applicable and fitted, condition monitoring. For instance, within the scope of a PMS system the following cases may occur:

- switchboard A is surveyed based on the regular expiry date of the class renewal survey
- lubricating oil pump B is surveyed based on CSM scope and periodicity
- diesel engine C is surveyed based on running hours
- turbo pump D is surveyed based on condition monitoring.

1.1.3 In general, the survey intervals for items surveyed under the PMS system should not exceed those specified for the CSM. However, for components where the maintenance is based on running hours, longer intervals may be accepted as long as the intervals are based on the manufacturer's recommendations.

1.1.4 The Chief Engineer shall be the responsible person on board in charge of the PMS.

The conditions related to Chief Engineer's inspections within the scope of PMS are given in Ch 2, App 2.

Items surveyed by this authorised Chief Engineer will be subject to the confirmatory survey as detailed in Ch 2, App 2.

Documentation on overhauls of items covered by the PMS are to be reported and signed by the Chief Engineer.

1.1.5 The conditions and procedures for the review of a PMS are indicated in [2].

1.1.6 For machinery undergoing maintenance based on condition monitoring, reference is made to Ch 2, App 4.

2 Conditions and procedures for the review of the system

2.1 General

2.1.1 The PMS documentation is to be subject to a consistency check. To this end the Owner is to make a formal request to the Society and provide the documentation and information specified in [2.2], combined in a manual describing the proposed scheme and including sample copies of the different documents to be used during the implementation of the scheme. The PMS is to be programmed and maintained by a computerized system. However, this may not be applied to the current already reviewed schemes.

2.1.2 When using computerised systems, access for updating of the maintenance documentation and the maintenance programmes is only granted to the person responsible for the PMS or another person authorised by him.

The computerised systems are to include a back-up procedure, which is to be activated at regular intervals.

The Owner himself is to confirm to the Society, by written declaration, that the required functionalities of the system are met. Or, alternatively, the Society may approve the software upon specific request.

2.2 Documentation

2.2.1 The documentation to be submitted is the manual mentioned above, which is to include:

- a) a description of the scheme and its application on board as well as the proposed organisation chart identifying the areas of responsibility and the people responsible for the PMS on board
- b) the document flow and pertinent filing procedure
- c) the list of items of machinery and components to be considered for classification in the PMS, distinguishing for each the principle of survey periodicity used as indicated in [1.1.2]
- d) the procedure for the identification of the items listed in c), which is to be compatible with the identification system adopted by the Society
- e) the scope and time schedule of the maintenance procedures for each item listed in c), including acceptable limit conditions of the parameters to be monitored based on the manufacturers' recommendations or recognised standards and laid down in appropriate preventive maintenance sheets.

2.3 Information on board

2.3.1 The following information is to be available on board:

- a) all the documentation listed in [2.2], duly updated
- b) the maintenance instructions including routine tests and inspections for each item of machinery, as applicable (supplied by the manufacturer or by the shipyard)
- c) reference documentation (trend investigation procedures etc.)
- d) the records of maintenance performed, including conditions found, repairs carried out, spare parts fitted
- e) the list of personnel on board in charge of the PMS management.

2.4 List of items

2.4.1 Ships subject to the planned maintenance survey system are provided with lists of items to be surveyed under this system, as indicated in [5.2.9].

3 Implementation of the system

3.1

3.1.1 When the documentation submitted has been checked for consistency and the PMS system has been implemented on board and used for a sufficient period (which is not to exceed one year) so that all personnel become familiar with it, a survey is to be carried out in order to start the system and make it officially operational. The scope of this survey, referred to as Implementation Survey, is given in [5.1.1].

3.1.2 Upon the successful outcome of the Implementation Survey, the PMS is considered approved.

4 Retention and withdrawal of the system

4.1

4.1.1 The PMS system is retained throughout the class period provided that:

- an annual report covering the year's service is supplied to the Society in accordance with [5.2.8]
- an annual audit in accordance with [5.2] is satisfactorily completed
- any change to the approved PMS is submitted to the Society for agreement.

4.1.2 The survey arrangement for machinery according to the PMS may be withdrawn by the Society if the PMS is not satisfactorily operated on account of either the maintenance records or the general condition of the machinery or the failure to observe the agreed intervals between overhauls.

4.1.3 The Owner may discontinue the PMS at any time by informing the Society in writing. In this case, the items which have been inspected under the PMS since the last annual audit will be credited for class at the discretion of the attending Surveyor.

4.1.4 In the case of sale or change of management of the ship or classification after construction, the assignment of the PMS will be reconsidered.

5 Surveys

5.1 Implementation survey

5.1.1 The implementation survey is to be carried out by a Surveyor of the Society, as stated in [3.1.1], within one year from the date of approval of the PMS.

5.1.2 The scope of this survey is to verify that:

- the PMS is implemented in accordance with the documentation which has been checked and is suitable for the type and complexity of the components and systems on board
- the documentation required for the annual audit is produced by the PMS
- the requirements of surveys and testing for retention of class are complied with
- the shipboard personnel are familiar with the PMS procedures.

Upon the successful outcome of the survey confirming the proper implementation of the PMS, the system is considered operational subject to the submission to the Society of a report describing the PMS.

5.2 Annual audit and confirmatory surveys

5.2.1 Once the PMS system is implemented, the continued compliance with the requirements for checks, overhauls and repairs, where needed, indicated in [2] is to be verified by means of annual audits and confirmatory surveys in order to confirm the validity of the approved survey scheme system.

5.2.2 The annual audit and confirmatory surveys are to be carried out in conjunction with the annual class surveys.

5.2.3 The purpose of this audit is to verify that the scheme is being correctly operated, in particular that all items (to be surveyed in the relevant period) have actually been surveyed in due time. A general examination of the items concerned is carried out.

5.2.4 The maintenance and performance records are examined to verify that the machinery has been functioning satisfactorily since the previous survey or audit or, if necessary, that the necessary measures have been taken in response to machinery operating parameters exceeding acceptable tolerances, and that the overhaul intervals have been observed.

5.2.5 Written reports of breakdown or malfunction are to be made available.

5.2.6 The description of the repairs, if any, carried out is to be examined. Any machinery part or component which has been replaced by a spare due to damage is to be retained on board, where possible. On this occasion such replaced parts are to be submitted to the examination of the Surveyor.

5.2.7 The Surveyor also checks that the personnel on board in charge of the PMS have the appropriate authorisation (see Ch 2, App 2).

5.2.8 An annual report covering the year's service is to be supplied to the Society. It is to include the information as required by items c) and e) of [2.2.1] above, as well as the information on changes to other requirements in [2.2.1].

The Surveyor is to review this annual report or verify that it has been reviewed by the Society.

5.2.9 The Surveyor carries out a confirmatory survey of the items which have been surveyed by the Chief Engineer and decides which items can be confirmed for classification, on the PMS list of items.

5.3 Damage and repairs

5.3.1 Damage to components or items of machinery covered by the PMS which may affect the class is to be reported to the Society. Where applicable, a Surveyor will attend on board, survey the damaged items and, on the basis of the survey results, decide whether conditions of class are to be imposed.

5.3.2 All parts of machinery or components which need to undergo substantial repairs are to be surveyed before, during and after the repairs, as deemed appropriate by the Surveyor. Any repair and corrective action regarding machinery under PMS system shall be recorded in the PMS logbook and repairs verified by the Surveyor at the annual audit.

5.3.3 In the case of overdue condition of class or records of unrepaired damage which may affect the PMS, the relevant items are to be taken out of the PMS until the conditions of class have been fulfilled or the repairs carried out.

APPENDIX 2

CSM AND PMS SYSTEMS: SURVEYS CARRIED OUT BY THE CHIEF ENGINEER

1 Conditions

1.1

1.1.1 The basic conditions for the acknowledgment of surveys carried out by Chief Engineers are specified hereafter. Consideration may be given to other conditions on a case by case basis.

1.1.2 An Owner's attestation, confirming that the Chief Engineer is duly qualified to carry out the inspection of the machinery items when the CSM system or PMS system, as applicable, is implemented on-board ships in accordance with the requirements in [2.1.1] and [2.1.2], is to be made available to the Surveyor on-board.

2 Limits of the interventions

2.1

2.1.1 For ships where the CSM system is implemented, the following items of the class renewal survey for machinery cannot be inspected by the Chief Engineer:

- pressure vessels
- main and auxiliary turbines
- main reduction gears
- turbochargers of main propulsion internal combustion engines
- intermediate shafting and associated bearings.

2.1.2 For ships where the PMS system is implemented, all items covered by the system can be surveyed by the Chief Engineer, with the exception of pressure vessels.

2.1.3 In no case may the surveys of tailshafts and boilers, which are items not included in the scope of the class renewal survey, be carried out by the Chief Engineer.

3 Procedure for carrying out surveys

3.1 General

3.1.1 As regards the procedure for carrying out surveys, the Owner is to inform the Chief Engineer that surveys are to be conducted in accordance with the Rules of the Society and, specifically, the requirements for class renewal surveys related to machinery and systems contained in Ch 3, Sec 3, [3].

It is the responsibility of the ship's Captain and Chief Engineer to decide the date and place for the survey of each component in order to avoid possible accidents (fire included) in the event of damage to the unit(s) remaining in service.

Some guidelines for the Chief Engineer relevant to the dismantling and inspections of main components of the machinery installation are given below.

The items and/or machinery which, as a result of the surveys, are replaced due to wear, damage or defects, are to be kept on board until they are inspected by a Surveyor of the Society.

3.2 Main diesel engines

3.2.1 The following items are to be surveyed as indicated:

- the top and bottom halves of the main bearings are to be removed and inspected, and the clearances are to be taken, recorded and compared with the limits recommended by the engine builder
- the top and bottom halves of bottom end connecting rod bearings are to be examined, and the clearances are to be taken, recorded and compared with the limits recommended by the engine builder
- crankpins, journals and webs are to be examined for crack detection, mainly at the fillets and in the vicinity of the lubricating oil holes
- crankshaft deflections are to be taken and recorded at regular intervals, enabling verification of the trend when they are taken in the presence of the Society's Surveyor. This operation is to be effected bearing in mind that during the readings the journals are to be steady on their bearings
- other parts exposed to wear or operating incidents are to be carefully examined and the results recorded. In particular, the wear of liners is to be measured and recorded.

3.3 Auxiliary diesel engines

3.3.1 The survey generally consists of the complete dismantling of the engine and a careful examination of those items most liable to be exposed to wear or operating incidents. In particular:

- crankshaft deflections and wear of cylinder liners are to be measured
- the crankshaft is to be checked by means of dye penetrant in way of fillets and lubricating oil holes
- all top halves of the main bearings together with at least two bottom halves are to be dismantled
- crankcase explosion relief valves, if fitted, are to be checked.

3.4 Reciprocating compressors

3.4.1 The survey is to include:

- the dismantling of pistons and valves for inspection
- the examination and testing of the nest of cooler tubes
- the verification of safety relief valves after reassembling.

3.5 Coolers, condensers, heaters

3.5.1 The survey is to include:

- the dismantling of the covers
- the examination of the nest of tubes
- the testing of the nest of tubes, if necessary.

3.6 Electrical switchboard

3.6.1 The survey is to include:

- the cleaning of the switchboard
- the verification of the connection assemblies, locking device tightening and busbar tightening
- the examination of the condition of the circuit-breakers, switches and fuses
- the verification of the contacts and screens
- the checking of the measuring instruments, which are to be re-calibrated or replaced, if inaccurate
- the insulation resistance test.

3.7 a.c. and d.c. generators

3.7.1 The survey is to include:

- the removal of protection plates and brush carriers
- the cleaning of field coils and armature windings
- the verification of proper contact of brushes, which are to be renewed if excessively worn
- the verification of commutators and sliprings
- the measurement of air gap clearances
- the checking of journals and bearings
- the insulation resistance test.

3.8 Other items (pumps, electric motors, etc.)

3.8.1 The survey is generally to include the complete dismantling for inspection of the main parts exposed to wear or operating incidents, such as bearings, casings, impellers and rotors.

4 Records of surveys carried out

4.1

4.1.1 The surveys carried out by the Chief Engineer are to be recorded in the engine/machinery log-book and a survey report is to be prepared for each item surveyed.

The report is generally to be drawn up in English; however, for ships trading in specific restricted areas the use of the language of the country concerned will be accepted.

The report may be provided in hard copy or using a computerised recording system.

4.1.2 The report is to indicate the following information:

- identification data:
 - name of ship and register number
 - name of Chief Engineer and Owner's attestation
 - date and place (port or voyage leg) of the survey
 - reference of the item in the CSM or PMS list, and description of the item
- inspection conducted:
 - the type of inspection carried out: visual external examination, internal examination after dismantling, overhaul
 - readings performed, when applicable: clearances, measurements, working pressure, or other working parameters of the equipment
 - inspection findings: corrosion, fractures, pieces of equipment worn out, broken or missing
- maintenance and repairs carried out and parts replaced
- results of tests performed after the inspection, such as working test, pressure test.

For sake of completeness, other documentation such as sketches, photos, measurement reports may be attached to the report.

The report is to be signed by the Chief Engineer.

5 Confirmatory survey

5.1

5.1.1 A confirmatory survey, to be carried out by a Surveyor of the Society, is to be requested according to the following principle:

- for ships under the CSM system, within a reasonably short time from the date of the surveys carried out by the Chief Engineer, and, in any case, in the first port which is under the jurisdiction of an Office of the Society
- for ships under the PMS system, at the next annual audit (see Ch 2, App 1, [5.2]).

5.1.2 The Surveyor is to be supplied with a copy of this survey report and also shown the engine log-book.

5.1.3 The Surveyor carries out an external examination of the relevant items and parts replaced and, if applicable, attends running tests. If doubts arise, the Surveyor may request dismantling as deemed necessary.

5.1.4 For confirmatory survey of the main engine crankshaft and bearings, the Surveyor performs the following:

- check of condition monitoring records
- check of crankshaft deflection readings
- check of bearing clearances (where possible)
- checks for signs of wiped or broken white metal in the crankcase or filters

- check of the witness marks of shrink fits of crankshafts
- check of the bedplate structure (inside and outside)
- check that the condition of crankpins, journals and associated bearings is duly recorded.

5.1.5 Where the confirmatory survey is performed with an abnormal delay, the inspection is to be more extensive and, if necessary, the due surveys are to be completely repeated.

5.1.6 The date of the execution of the surveys will be assumed to be the date of the confirmatory survey.

6 Suspension of the Chief Engineer's authorization

6.1

6.1.1 Where the condition of the items surveyed by the Chief Engineer as specified in his or her reports does not correspond to the findings of the attending Surveyor, or in case of doubt on the general maintenance of the machinery installation, the Society may request the Owner to withdraw the Chief Engineer qualification attestation until further training and re-assessment of his/her qualification.

APPENDIX 3

THICKNESS MEASUREMENTS: EXTENT, DETERMINATION OF LOCATIONS, ACCEPTANCE CRITERIA

1 General

1.1 Aim of the Appendix

1.1.1 Thickness measurements are a major part of surveys to be carried out for the maintenance of class, and the analysis of these measurements is a prominent factor in the determination and extent of the repairs and renewals of the ship's structure.

1.1.2 The Appendix is intended to provide Owners, companies performing thickness measurements and the Society's Surveyors with a uniform means with a view to fulfilling Rule requirements for thickness measurements. In particular, it will enable all the above-mentioned parties to carry out:

- the planning and preparation
- the determination of extent and location, and
- the analysis

of the thickness measurements in cooperation.

1.1.3 It is to be noted that this Appendix also takes into account specific requirements for thickness measurements relevant to close-up surveys of ships which are subject to the Enhanced Survey Program (ESP).

1.1.4 This Appendix is also to be used for the thickness measurements of ships assigned the notation **VerisSTAR-HULL SIS** (see Ch 5, Sec 2 and Part F, Chapter 1). However, the acceptance criteria for thickness measurements specific to this notation are given in Pt F, Ch 1, Sec 1 which refers to Ch 2, App 3 or Pt F, Ch 1, App 2 for items as deemed appropriate by the Society.

1.2 Scope of the Appendix

1.2.1 Separate Articles below provide the following information:

- references to rule requirements and some additional information on the extent of the thickness measurements to be performed during surveys according to types of ships and related surveys (see [2])
- locations of the measurements for the main parts of the ship (see [3])
- how to analyse the results of thickness measurements (see [4]).

Tables and sketches are also given to detail the above points according to the types of ships.

2 Rule requirements for the extent of measurements

2.1 General

2.1.1 For the maintenance of class, thickness measurements may be required during annual, intermediate and class renewal surveys.

Tab 1 gives the references to the requirements for minimum thickness measurements indicated in Part A, Chapter 3 and Part A, Chapter 4 for each service notation and related to the different types of surveys.

Some additional explanations are also given about the wording used in the Rules as well as the general principles of the required thickness measurements during class renewal surveys.

Table 1 : References to rule requirements related to thickness measurements

SERVICE NOTATION	TYPE OF SURVEY		
	CLASS RENEWAL	INTERMEDIATE	ANNUAL
all service notations except those in other rows	Ch 3, Sec 3, [2.6] and Ch 3, Sec 3, Tab 3: systematic measurements and suspect areas Where substantial corrosion is found, the extent of thickness measurements may be increased to the Surveyor's satisfaction, using Ch 3, Sec 3, Tab 4 as guidance	Ch 3, Sec 2, Tab 1: thickness measurements to be taken if deemed necessary by the Surveyor Where substantial corrosion is found, the extent of thickness measurements may be increased to the Surveyor's satisfaction, using Ch 3, Sec 3, Tab 4 as guidance	Ch 3, Sec 1, [2.1.2]: areas of substantial corrosion identified at previous surveys Where substantial corrosion is found, the extent of thickness measurements may be increased to the Surveyor's satisfaction, using Ch 3, Sec 3, Tab 4 as guidance

SERVICE NOTATION	TYPE OF SURVEY		
	CLASS RENEWAL	INTERMEDIATE	ANNUAL
bulk carrier ESP bulk carrier BC-A ESP bulk carrier BC-B ESP bulk carrier BC-C ESP ore carrier ESP combination carrier/OBO ESP combination carrier/OOC ESP	<p>Ch 4, Sec 2, [4.1] and Ch 4, Sec 2, [4.6]: planning and general requirements</p> <p>Ch 4, Sec 2, Tab 8 and Ch 4, Sec 2, Tab 9: measurements of elements subjected to close-up survey</p> <p>Ch 4, Sec 2, Tab 11: extent of systematic thickness measurements</p> <p>Ch 4, Sec 2, Tab 12 to Ch 4, Sec 2, Tab 20, according to the different locations, where substantial corrosion is found</p>	<ul style="list-style-type: none"> Ships 10 years of age or less: Ch 4, Sec 2, Tab 3 and Ch 4, Sec 2, Tab 5 for cargo holds Ch 4, Sec 2, Tab 4 and Ch 4, Sec 2, Tab 6 for salt water ballast tanks Ch 4, Sec 2, Tab 12 to Ch 4, Sec 2, Tab 20, according to the different locations, where substantial corrosion is found Ships over 10 years of age: see references given for class renewal survey 	<p>Ch 4, Sec 2, Tab 1 and Ch 4, Sec 2, Tab 2 for cargo holds and when deemed necessary by the Surveyor</p> <p>Ch 4, Sec 2, [2.4] for salt ballast tanks and when deemed necessary by the Surveyor</p> <p>Ch 4, Sec 2, Tab 12 to Ch 4, Sec 2, Tab 20, according to the different locations, where substantial corrosion is found</p>
oil tanker ESP combination carrier/OBO ESP combination carrier/OOC ESP	<p>Ch 4, Sec 3, [6.1] and Ch 4, Sec 3, [6.5]: planning and general requirements</p> <p>Ch 4, Sec 3, Tab 1 and Ch 4, Sec 3, Tab 2: measurements of elements subjected to close-up survey</p> <p>Ch 4, Sec 3, Tab 3: extent of systematic thickness measurements</p> <p>Ch 4, Sec 3, Tab 4 and Ch 4, Sec 3, Tab 5, according to the different locations, where substantial corrosion is found</p>	<ul style="list-style-type: none"> Ships 10 years of age or less: Ch 4, Sec 3, [4.2] for salt ballast tanks Ch 4, Sec 3, Tab 4 and Ch 4, Sec 3, Tab 5, according to the different locations, where substantial corrosion is found Ships over 10 years of age: see references given for class renewal survey 	<p>Ch 4, Sec 3, [2.4] limited to salt ballast tanks and when deemed necessary by the Surveyor</p> <p>Ch 4, Sec 3, Tab 4 and Ch 4, Sec 3, Tab 5, according to the different locations, where substantial corrosion is found</p>
chemical tanker ESP	<p>Ch 4, Sec 4, [6.1] and Ch 4, Sec 4, [6.5]: planning and general requirements</p> <p>Ch 4, Sec 4, Tab 1: measurements of elements subjected to close-up survey</p> <p>Ch 4, Sec 4, Tab 3: extent of systematic thickness measurements</p> <p>Ch 4, Sec 4, Tab 4: according to the different locations, where substantial corrosion is found</p>	<ul style="list-style-type: none"> Ships 10 years of age or less: Ch 4, Sec 4, [4.2] for salt ballast tanks Ch 4, Sec 4, Tab 4: according to the different locations, where substantial corrosion is found Ships over 10 years of age: see references given for class renewal survey 	<p>Ch 4, Sec 4, [2.4] limited to salt ballast tanks and when deemed necessary by the Surveyor</p> <p>Ch 4, Sec 4, Tab 4: according to the different locations, where substantial corrosion is found</p>
liquefied gas carrier	<p>Ch 4, Sec 5, [6.2], Ch 4, Sec 5, [6.3.2] and Ch 4, Sec 5, [6.5]: planning and general requirements</p> <p>Ch 4, Sec 5, Tab 2: measurements of elements subjected to close-up survey</p> <p>Ch 4, Sec 5, Tab 3: extent of systematic thickness measurements</p> <p>Where substantial corrosion is found, the extent of thickness measurements may be increased to the Surveyor's satisfaction, using Ch 3, Sec 3, Tab 4 as guidance</p>	<p>Ch 4, Sec 5, Tab 1: thickness measurements to be taken if deemed necessary by the Surveyor</p> <p>Where substantial corrosion is found, the extent of thickness measurements may be increased to the Surveyor's satisfaction, using Ch 3, Sec 3, Tab 4 as guidance</p>	<p>Ch 4, Sec 5, [2.5.2] limited to ballast tanks and when deemed necessary by the Surveyor</p> <p>Where substantial corrosion is found, the extent of thickness measurements may be increased to the Surveyor's satisfaction, using Ch 3, Sec 3, Tab 4 as guidance</p>
general cargo ship	<p>Ch 4, Sec 7, [4.1], Ch 4, Sec 7, [4.2] and Ch 4, Sec 7, [4.5]: planning and general requirements</p> <p>Ch 4, Sec 7, Tab 4: measurements of elements subjected to close-up survey</p> <p>Ch 4, Sec 7, Tab 5: extent of systematic thickness measurements</p> <p>Where substantial corrosion is found, the extent of thickness measurements may be increased to the Surveyor's satisfaction, using Ch 4, Sec 7, Tab 6 as guidance</p>	<ul style="list-style-type: none"> Ships 15 years of age or less: Ch 4, Sec 7, Tab 2 for cargo holds Ch 4, Sec 7, Tab 3 for ballast tanks Ch 4, Sec 7, Tab 6, where substantial corrosion is found Ships over 15 years of age: see references given for class renewal survey 	<p>Ch 4, Sec 7, Tab 1 for cargo holds when deemed necessary by the Surveyor or where extensive corrosion exists</p> <p>Ch 4, Sec 7, [2.4] for ballast tanks when deemed necessary by the Surveyor or where extensive corrosion exists</p> <p>Ch 4, Sec 7, Tab 6 where substantial corrosion is found</p>

2.2 Class renewal survey: all ships except those submitted to ESP or equivalent

2.2.1 The thickness measurements required by the Rules consist of:

- systematic thickness measurements, i.e. measurements of different parts of the structure, in order to assess the overall and local strength of the ship
- measurements of suspect areas as defined in Ch 2, Sec 2, [2.2.11]
- additional measurements on areas determined as affected by substantial corrosion as defined in Ch 2, Sec 2, [2.2.7].

2.3 Class renewal survey: ships submitted to ESP or equivalent

2.3.1 The thickness measurements required by the Rules consist of:

- systematic thickness measurements in order to assess the overall and local strength of the ship
- thickness measurements as indicated in the program of close-up survey
- measurements of elements considered as suspect areas as defined in Ch 2, Sec 2, [2.2.11]
- additional measurements on areas determined as affected by substantial corrosion as defined in Ch 2, Sec 2, [2.2.7].

2.3.2 For the determination of close-up surveys and relevant thickness measurements as well as the areas considered as suspect areas, reference is to be made to the relevant Sections of Part A, Chapter 4 according to the different service notations of the ships.

3 Number and locations of measurements

3.1 General

3.1.1 Considering the extent of thickness measurements as required by the Rules and indicated in [2], the locations of the points to be measured are given here for the most important items of the structure. Thus the number of points can be estimated.

Note 1: This Article applies to ships built under the Common Structural Rules as well as ships not built under the Common Structural Rules, as specified.

3.2 Locations of points

3.2.1 Tab 2 provides explanations and/or interpretations for the application of those requirements indicated in the Rules which refer to both systematic thickness measurements related to the calculation of global hull girder strength and specific measurements connected to close-up surveys.

Figures are also given to facilitate the explanations and/or interpretations given in the table. These figures show typical arrangements of cargo ships, bulk carriers and oil tankers. Due to the various designs of the other ship types, figures are not given to cover all the different cases. However, the figures provided here may be used as guidance for ships other than those illustrated.

Table 2 : Interpretations of rule requirements for the locations and number of points to be measured

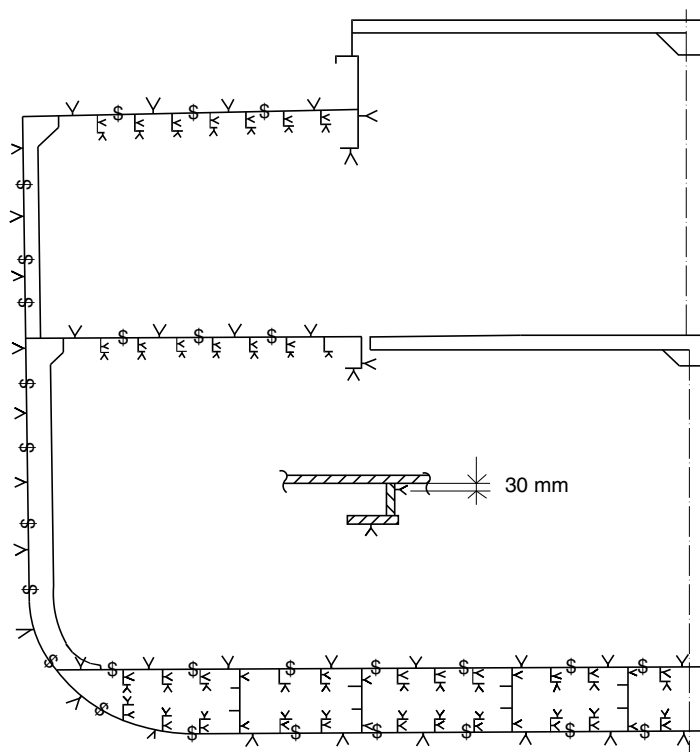
A) SYSTEMATIC MEASUREMENTS		
ITEM	INTERPRETATION	FIGURE
Selected plates on deck, tank top, bottom, double bottom and wind-and-water (for all ship types including CSR ships)	“Selected” means at least a single point on one out of three plates, to be chosen on representative areas of average corrosion	No figure
All deck, tank top and bottom plates and wind-and-water strakes (for all ship types including CSR ships)	At least two points on each plate to be taken either at each 1/4 extremity of plate or at representative areas of average corrosion	No figure
Transverse section (for all ship types including CSR ships)	Refer to the definition given in Ch 2, Sec 2, [2.2.5] One point to be taken on each plate. Both web and flange to be measured on longitudinals, if applicable (for CSR oil tankers) For tankers older than 10 years of age: within 0,1D (where D is the ship’s moulded depth) of the deck and bottom at each transverse section to be measured, every longitudinal and girder is to be measured on the web and face plate, and every plate is to be measured at one point between longitudinals (for CSR oil tankers)	Fig 1 for general cargo ships Fig 2 for bulk carriers including CSR bulk carriers Fig 3 for oil tankers Fig 15 for CSR oil tankers For other ship types, see [3.2.1]

All cargo hold hatch covers and coamings (for all ship types except CSR oil tankers)	Including plates and stiffeners (for CSR single skin and double skin bulk carriers)	Fig 4 for ships fitted with hold hatch covers and coamings
Bulkheads on ships other than bulk carriers, oil tankers, chemical tankers, liquefied gas carriers and CSR ships (for these ships refer to B) and C): CLOSE-UP SURVEYS AND RELATED MEASUREMENTS)	“Selected bulkheads” means at least 50% of the bulkheads	Fig 5 for general cargo ships. It may also apply to other ship types (see [3.2.1])
Selected internal structure such as floors and longitudinals, transverse frames, web frames, deck beams, ‘tween-decks, girders (for all ship types other than CSR ships)	The internal structural items to be measured in each space internally surveyed are to be at least 20% within the cargo area and 10% outside the cargo area	Fig 6 for general cargo ships. It may also apply to other ship types (see [3.2.1])
Transverse section of deck plating outside line of cargo hatch openings (for bulk carriers, ore carriers, combination carriers and CSR single skin and double skin bulk carriers)	Two single points on each deck plate (to be taken either at each 1/4 extremity of plate or at representative areas of average corrosion) between the ship sides and hatch coamings in the transverse section concerned	No figure
Transverse rings (1) in cargo and ballast tanks (for CSR oil tankers)	At least two points on each plate in a staggered pattern and two points on the corresponding flange where applicable. Minimum 4 points on the first plate below deck. Additional points in way of curved parts. At least one point on each of two stiffeners between stringers / longitudinal girders	Fig 16 for CSR oil tankers
One section of deck plating for the full beam of the ship within the cargo area (for oil tankers, chemical tankers and liquefied gas carriers, other than CSR ships)	Two single points on each deck plate (to be taken either at each 1/4 extremity of plate or at representative areas of average corrosion) in the transverse section concerned	No figure
All deck plating and under-deck structure inside line of hatch openings between cargo hold hatches (for CSR single skin and double skin bulk carriers)	«All deck plating» means at least two points on each plate to be taken either at each 1/4 extremity of plate or at representative areas of average corrosion. “Under deck structure”: at each short longitudinal girder: three points for web plating (fwd/middle/aft), single point for face plate, one point for web plating and one point for face plating of transverse beam in way. At each ends of transverse beams, one point for web plating and one point for face plating	Fig 10 for CSR single skin and double skin bulk carriers Extent of areas is shown in Ch 4, Sec 2, Fig 1 and Ch 4, Sec 2, Fig 3
B) CLOSE-UP SURVEYS AND RELATED MEASUREMENTS (oil tankers, chemical tankers, liquefied gas carriers and combination carriers)		
ITEM	INTERPRETATION	FIGURE
Web frame ring (for oil tankers and combination carriers other than CSR ships)	Refer to the definition given in Ch 4, Sec 3, Tab 1 “Adjacent structural members” means plating and stiffeners of deck, bottom, double bottom, sides and longitudinal bulkheads in the vicinity of the web frame ring	Extent of areas is shown as ① in Ch 4, Sec 3, Fig 1 Locations of points are given in Fig 13
Transverse section (for chemical tankers and liquefied gas carriers)	Refer to the definitions given in Ch 4, Sec 4, Tab 1 and Ch 4, Sec 5, Tab 2 “Adjacent structural members” means plating and stiffeners of deck, bottom, double bottom, sides and longitudinal bulkheads in the vicinity of the web frame ring	No figure
Deck transverse (for all ships other than CSR ships)	This is the upper part of the web frame ring including the adjacent structural members (see meaning given above). For chemical tankers it may be fitted on deck, i.e. outside the tank	Extent of areas is shown as ② in Ch 4, Sec 3, Fig 1 Locations of points are given in Fig 13

Deck and bottom transverses (for oil tankers other than CSR ships)	Refer to the definition given in Ch 4, Sec 3, Tab 1	Extent of areas is shown as ② and ③ in Ch 4, Sec 3, Fig 1 Locations of points are given in Fig 13
Transverse bulkheads (for all ships other than CSR ships)	“Complete” means the whole bulkhead including stringers and stiffeners and adjacent structural members as defined above “Lower part” means lower part of bulkhead up to 1/4 of ship’s depth or 2 metres above the lower stringer, whichever is the greater (stringers, stiffeners and adjacent structural members included)	Extent of areas is shown as ③ in Ch 4, Sec 3, Fig 1 Locations of points are given in Fig 14 Extent of areas is shown as ④ in Ch 4, Sec 3, Fig 1 Locations of points are given in Fig 14
Transverse bulkheads in cargo tanks (for CSR oil tankers)	At least two points on each plate. Minimum 4 points on the first plate below main deck At least one point on every third stiffener to be taken between each stringer At least two points on each plate of stringers and girders, and two points on the corresponding flange. Additional points in way of curved part Two points of each diaphragm plate of stools, if fitted.	Fig 17 for CSR oil tankers
Transverse bulkheads in ballast tanks (for CSR oil tankers)	At least 4 points on plates between stringers / longitudinal girders, or per plate if stringers/girders not fitted At least two points on each plate of stringers and girders, and two points on the corresponding flange. Additional points in way of curved part At least one point on two stiffeners between each stringer / longitudinal girder	Fig 18 for CSR oil tankers
Adjacent structural members (for CSR oil tankers)	On adjacent structural members one point per plate and one point on every third stiffener/longitudinal	No figure
All plating and internal structures (for chemical tankers and liquefied gas carriers)	Refer to the definitions given in Ch 4, Sec 4, Tab 1 and Ch 4, Sec 5, Tab 2	No figure
C) CLOSE-UP SURVEYS AND RELATED MEASUREMENTS (bulk carriers and ore carriers)		
ITEM	INTERPRETATION	FIGURE
Frames in cargo holds (for bulk carriers and ore carriers other than CSR ships)	25% of frames: one out of four frames should preferably be chosen throughout the cargo hold length on each side “Selected frames” means at least 3 frames on each side of cargo holds	Extent of areas is shown as ① in Ch 4, Sec 2, Fig 1 Locations of points are given in Fig 7
Selected side shell frames in cargo holds (for CSR single skin bulk carriers)	Includes side shell frame, upper and lower end attachments and adjacent shell plating 25% of frames: one out of four frames should preferably be chosen throughout the cargo hold length on each side 50% of frames: one out of two frames should preferably be chosen throughout the cargo hold length on each side «Selected frames» means at least 3 frames on each side of cargo holds	Fig 11 for CSR single skin bulk carriers Extent of areas is shown in Ch 4, Sec 2, Fig 1
Transverse frame in double skin tank (for CSR double skin bulk carriers)		Fig 2
Transverse bulkheads in cargo holds (for bulk carriers, ore carriers and CSR single skin and double skin bulk carriers)	Refer to the definition given in Ch 4, Sec 2, Tab 8 footnote (3) Two selected bulkheads: one is to be the bulkhead between the two foremost cargo holds and the second may be chosen in other positions (for CSR single skin and double skin bulk carriers)	Areas of measurements are shown in Ch 4, Sec 2, Fig 1 and Ch 4, Sec 2, Fig 3 Locations of points are given in Fig 8

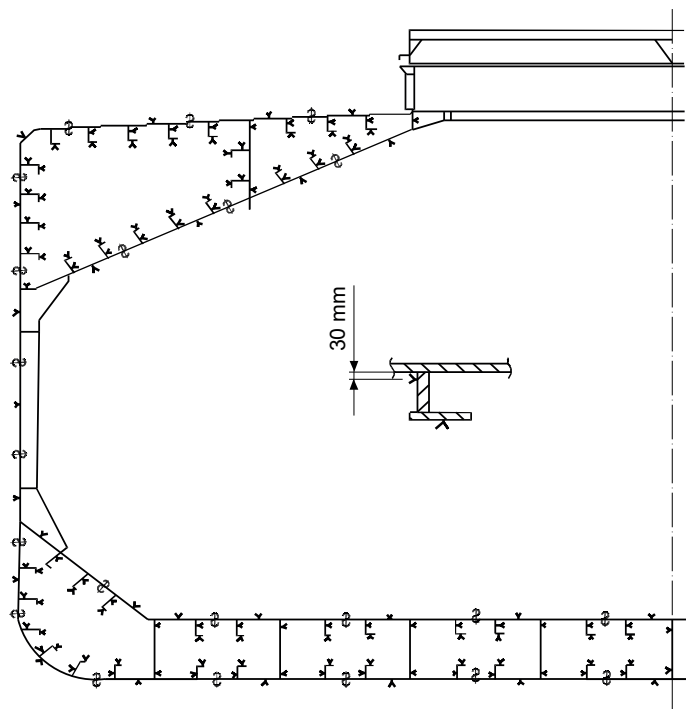
<p>One transverse bulkhead in each cargo hold (for bulk carriers, ore carriers and CSR single skin and double skin bulk carriers)</p>	<p>This means that the close-up survey and related thickness measurements are to be performed on one side of the bulkhead; the side is to be chosen based on the outcome of the overall survey of both sides. In the event of doubt, the Surveyor may also require (possibly partial) close-up survey on the other side</p>	<p>Areas of measurements are shown in Ch 4, Sec 2, Fig 1 and Ch 4, Sec 2, Fig 3 Locations of points are given in Fig 8</p>
<p>Transverse bulkheads in one topside/side, hopper and double bottom ballast tank (for bulk carriers, ore carriers and CSR single skin and double skin bulk carriers)</p>	<p>Includes bulkhead and stiffening systems (for CSR single skin and double skin bulk carriers) The ballast tank is to be chosen based on the history of ballasting among those prone to have the most severe conditions</p>	<p>Locations of points are given in Fig 9</p>
<p>Transverse webs in ballast tanks (for bulk carriers, ore carriers and CSR single skin and double skin bulk carriers)</p>	<p>Either one of the representative tanks of each type (i.e. topside or hopper or side tank) is to be chosen in the forward part Includes web plating, face plates, stiffeners and associated plating and longitudinals (for CSR single skin and double skin bulk carriers) "Associated plating and longitudinals" means adjacent plating and longitudinals of deck, bottom, side shell, slope, hopper and longitudinal bulkhead, as applicable</p>	<p>Extent of areas is shown as ② in Ch 4, Sec 2, Fig 1 and Ch 4, Sec 2, Fig 3 Locations of points are given in Fig 7 Locations of points are given in Fig 11 for CSR single skin bulk carriers and in Fig 12 for CSR double skin bulk carriers</p>
<p>Areas of deck plating inside line of hatch openings (for bulk carriers and ore carriers other than CSR ships)</p>	<p>"Selected" means at least a single point on one out of three plates, to be chosen on representative areas of average corrosion "All deck plating" means at least two points on each plate to be taken either at each 1/4 extremity of plate or at representative areas of average corrosion</p>	<p>Extent of areas is shown as ③ in Ch 4, Sec 2, Fig 1</p>
<p>(1) Transverse rings means all transverse material appearing in a cross-section of the ship's hull, in way of a double bottom floor, vertical web and deck transverse (definition from the Common Structural Rules).</p>		

Figure 1 : Transverse section of a general cargo ship

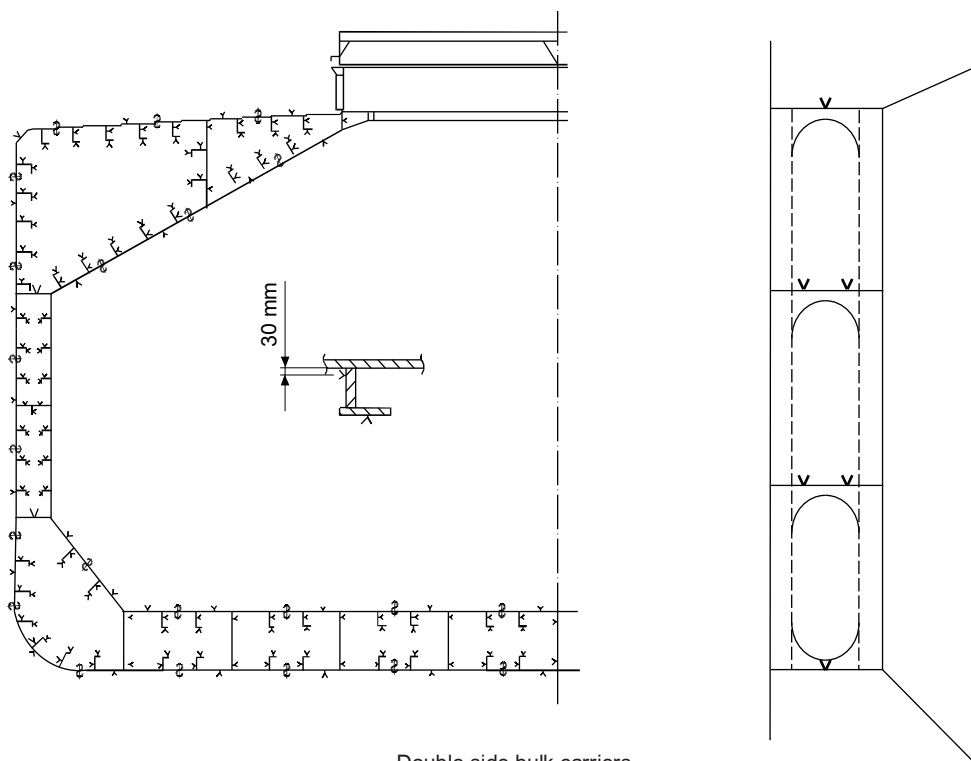


Measurements are to be taken on both port and starboard sides of the selected transverse section

Figure 2 : Transverse section of bulk carriers



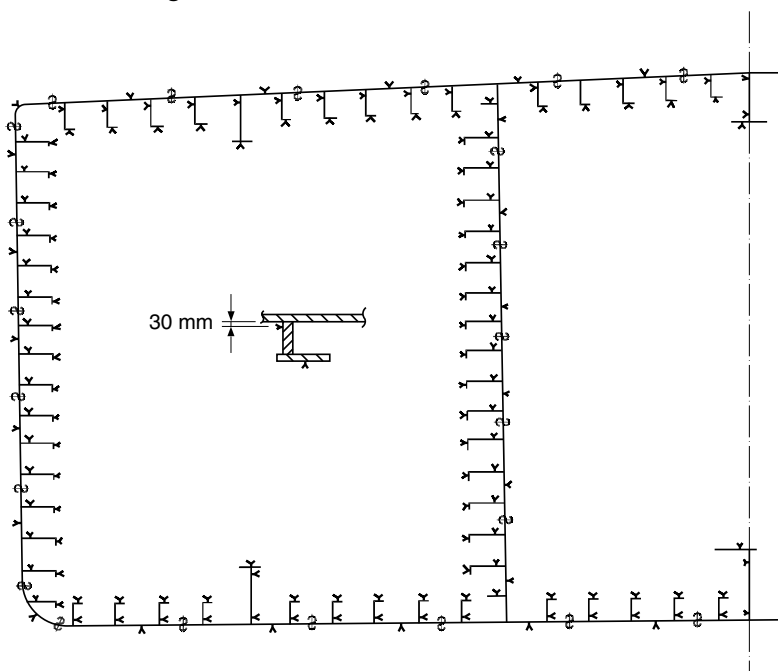
Single side bulk carriers



Double side bulk carriers

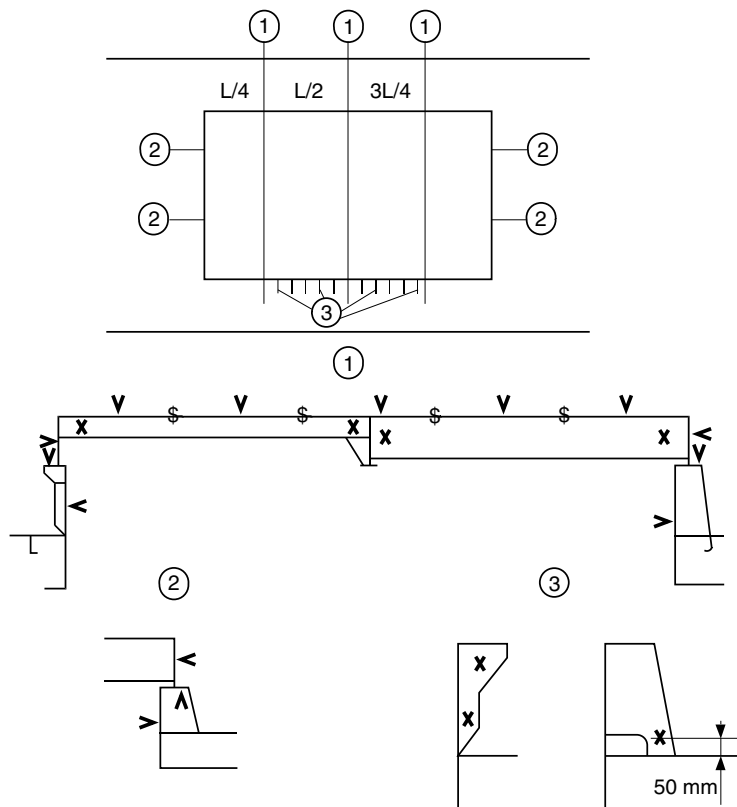
Measurements are to be taken on both port and starboard sides of the selected transverse section

Figure 3 : Transverse section of an oil tanker



Measurements are to be taken on both port and starboard sides of the selected transverse section

Figure 4 : Locations of measurements on hatch covers and coamings (valid for all ships fitted with hatch covers and coamings)



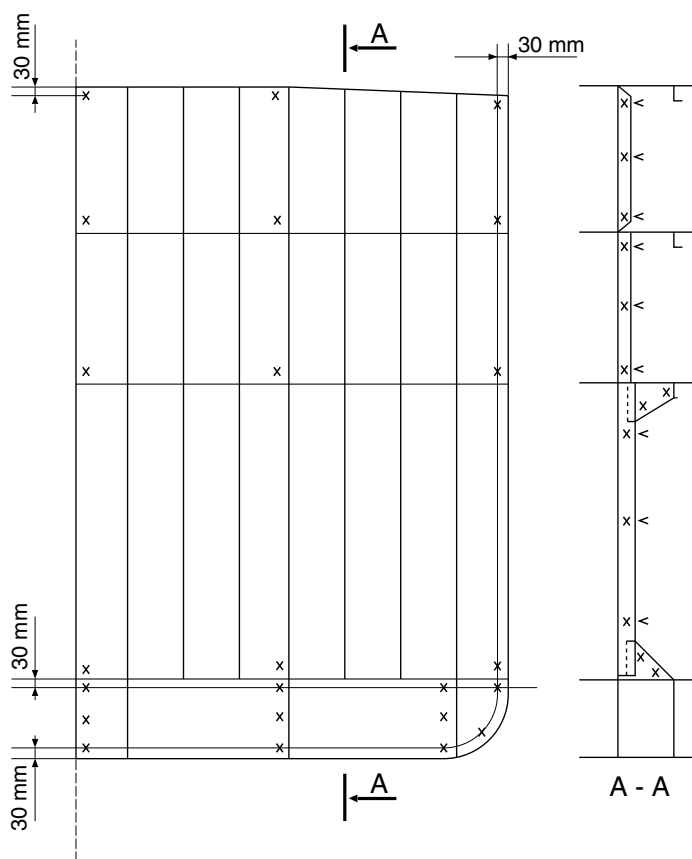
(1) Three sections at L/4, L/2, 3L/4 of hatch cover length, including:

- one measurement of each hatch cover plate and skirt plate
- measurements of adjacent beams and stiffeners
- one measurement of coaming plates and coaming flange, each side

(2) Measurements of both ends of hatch cover skirt plate, coaming plate and coaming flange

(3) One measurement of one out of three hatch coaming brackets and bars, on both sides and both ends

Figure 5 : Locations of measurements on bulkheads of general cargo ships



Cargo hold bulkhead/watertight floor plating to be measured as per main view

One stiffener out of three to be measured as per view A - A

Figure 6 : Locations of measurements on selected internal structural elements of general cargo ships

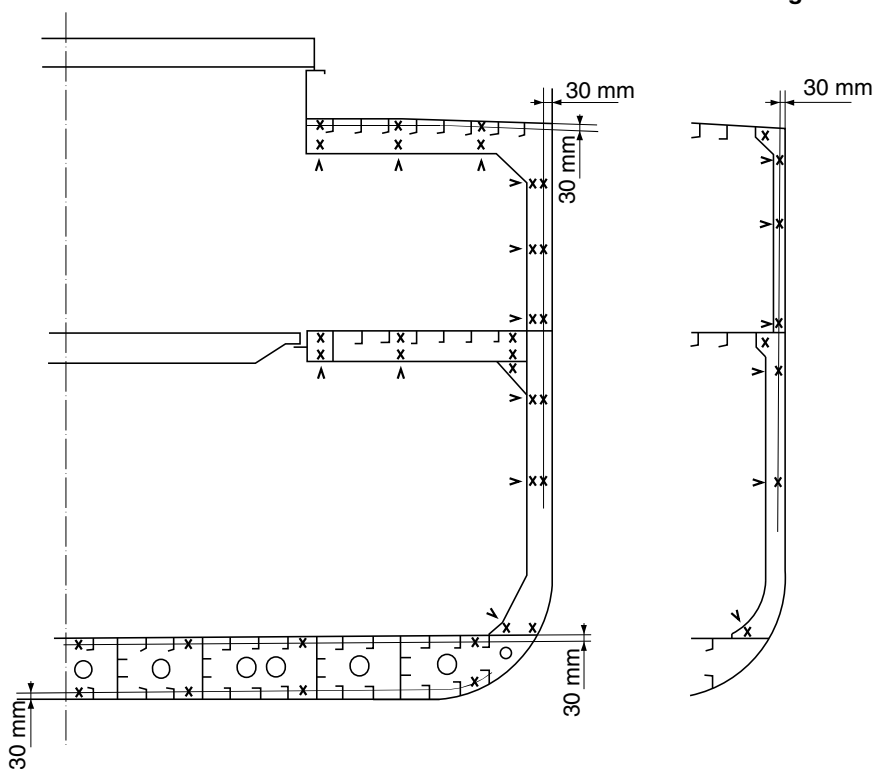


Figure 7 : Locations of measurements on structural members in cargo holds and ballast tanks of bulk carriers

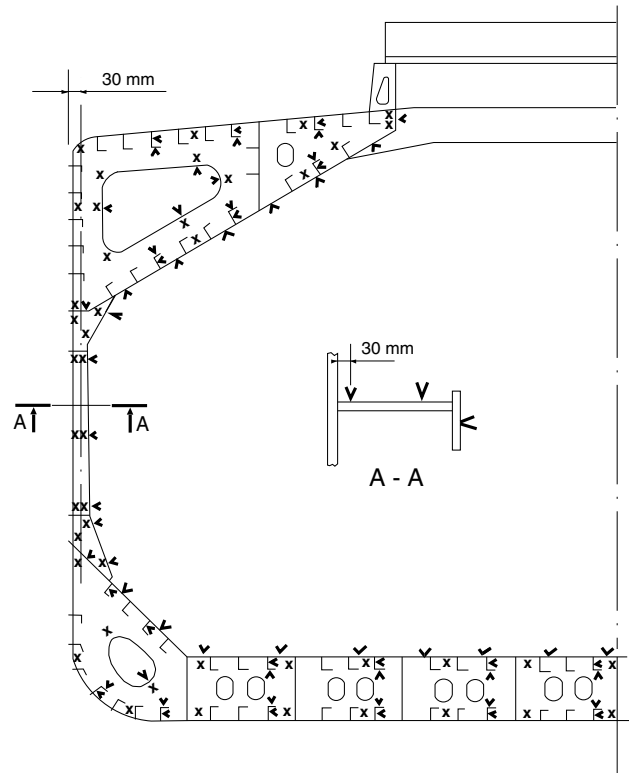
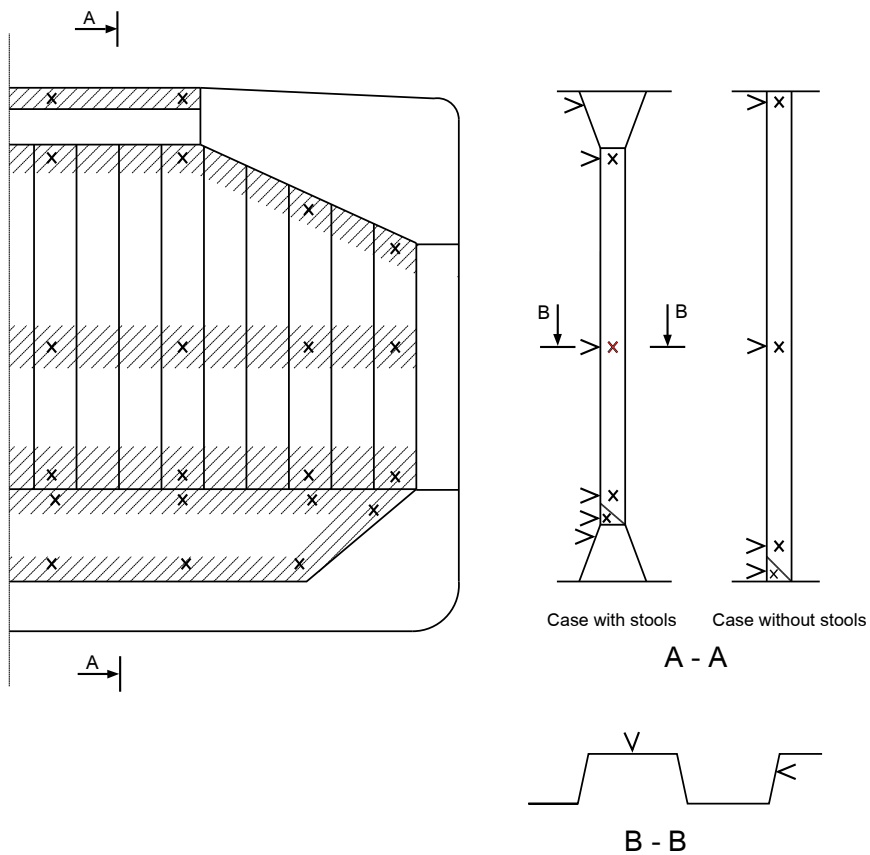
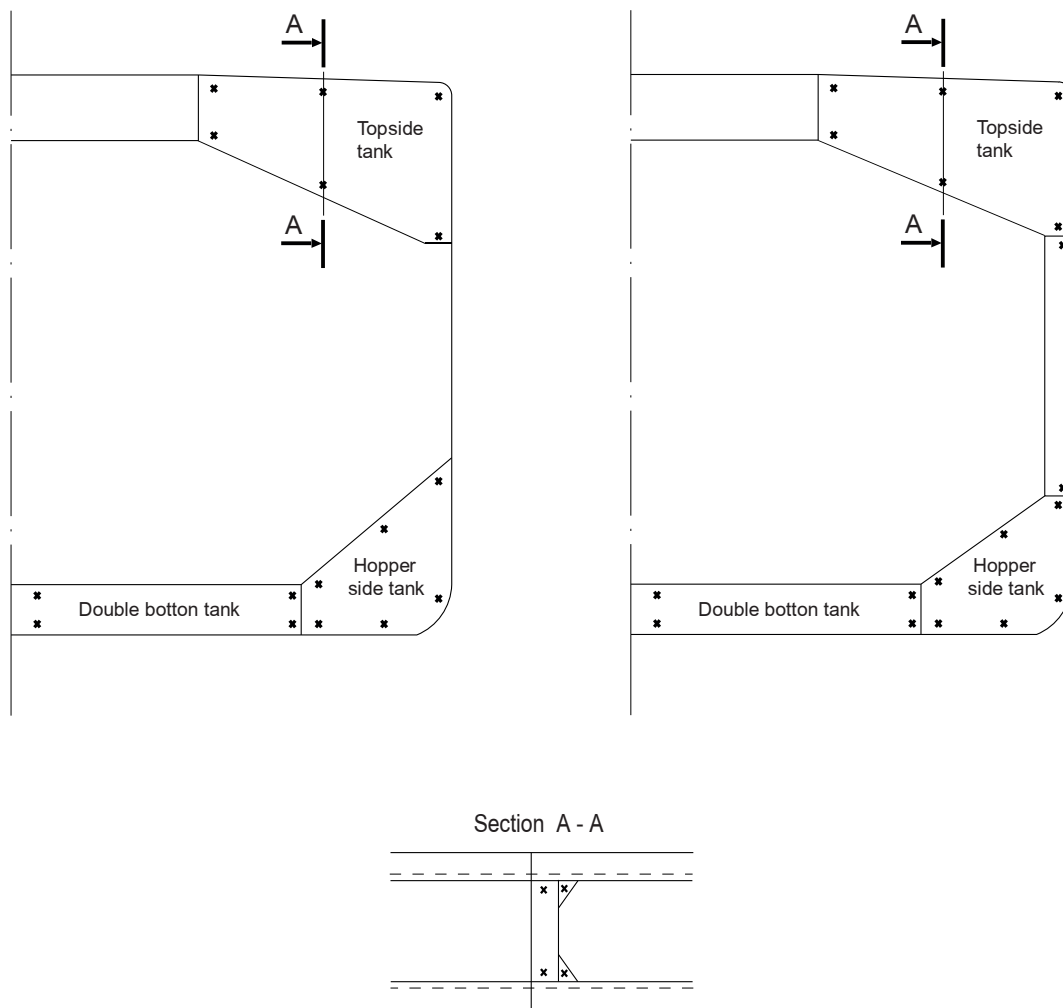


Figure 8 : Locations of measurements on cargo hold transverse bulkheads of bulk carriers (additional measurements to internal structure of upper and lower stools to be added, e.g. two points in the upper and two points in the lower stools to be indicated in section A-A)



Measurements to be taken in each shaded area as per views A - A and B - B

Figure 9 : Locations of measurements on transverse bulkheads of topside, hopper and double bottom tanks of bulk carriers (two additional measurements to internal structure of double bottom tank to be added at midspan)



Measurements to be taken in each vertical section as per view A - A

Figure 10 : Location of measurements on underdeck structure of CSR single skin and double skin bulk carriers

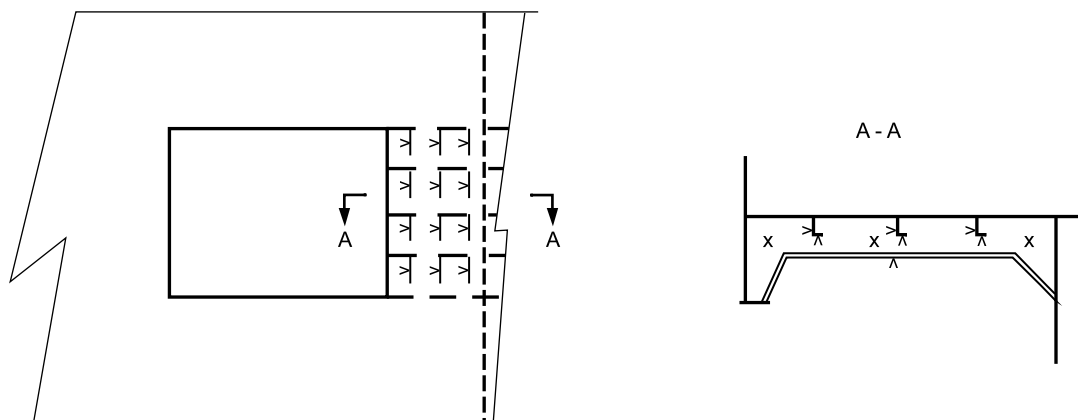
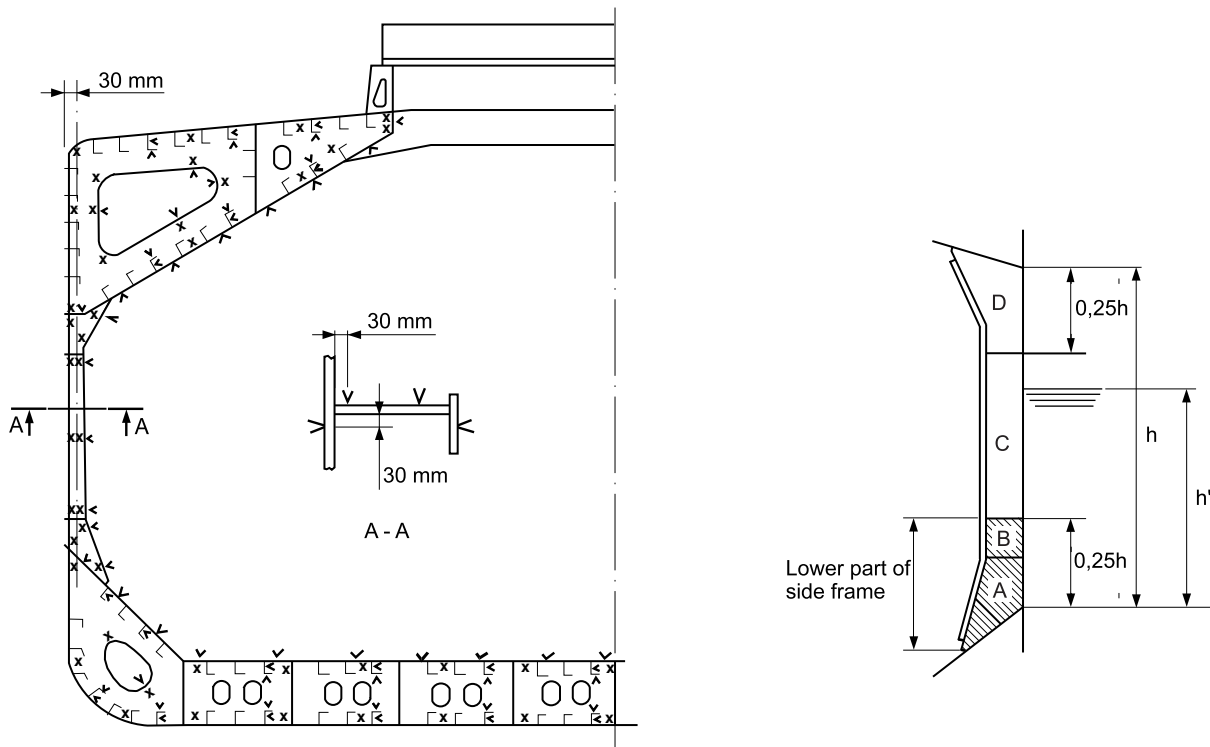


Figure 11 : Location of measurements on structural members in cargo holds and ballast tanks of CSR single skin bulk carriers



The gauging pattern for web plating is to be a three-point pattern for zones A, C and D, and a two-point pattern for zone B (see Figure). The gauging report is to reflect the average reading. The average reading is to be compared with the allowable thickness.

If the web plating has general corrosion, then this pattern is to be expanded to a five-point pattern.

Figure 12 : Location of measurements on structural members in ballast tanks of CSR double skin bulk carriers (topside or hopper or side tank)

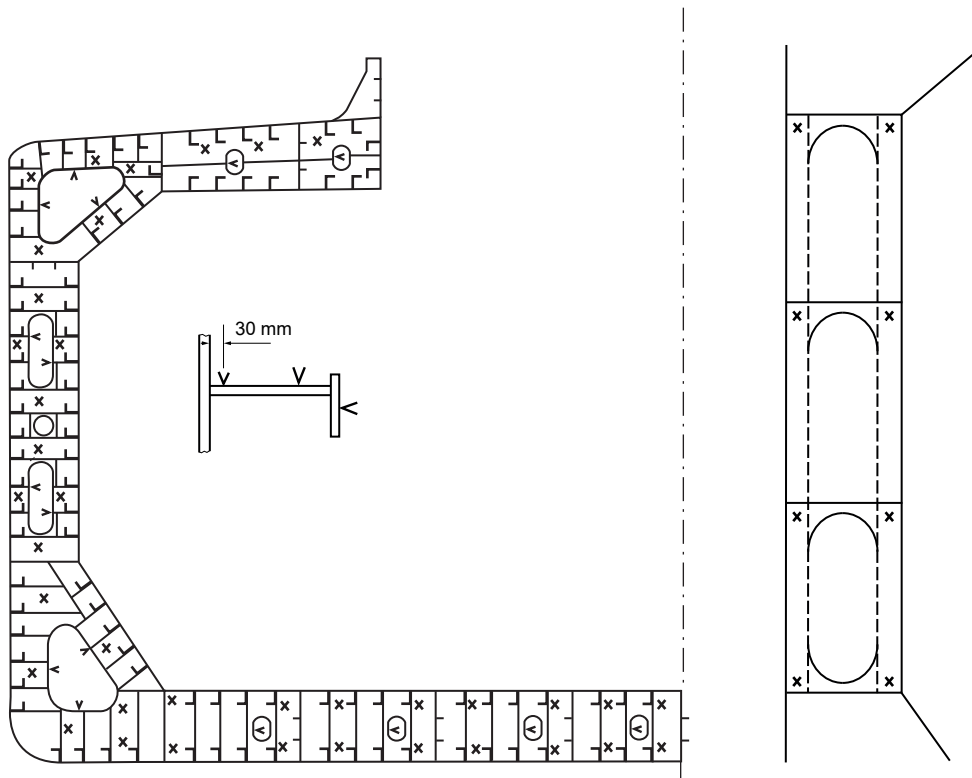


Figure 13 : Locations of measurements on web frame rings and longitudinal elements of oil tankers

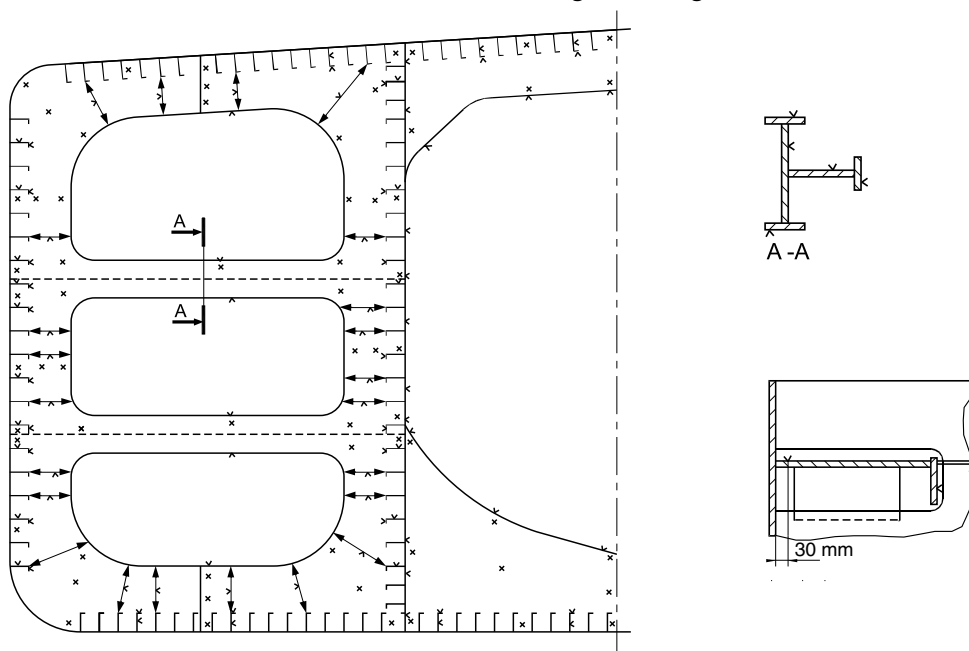
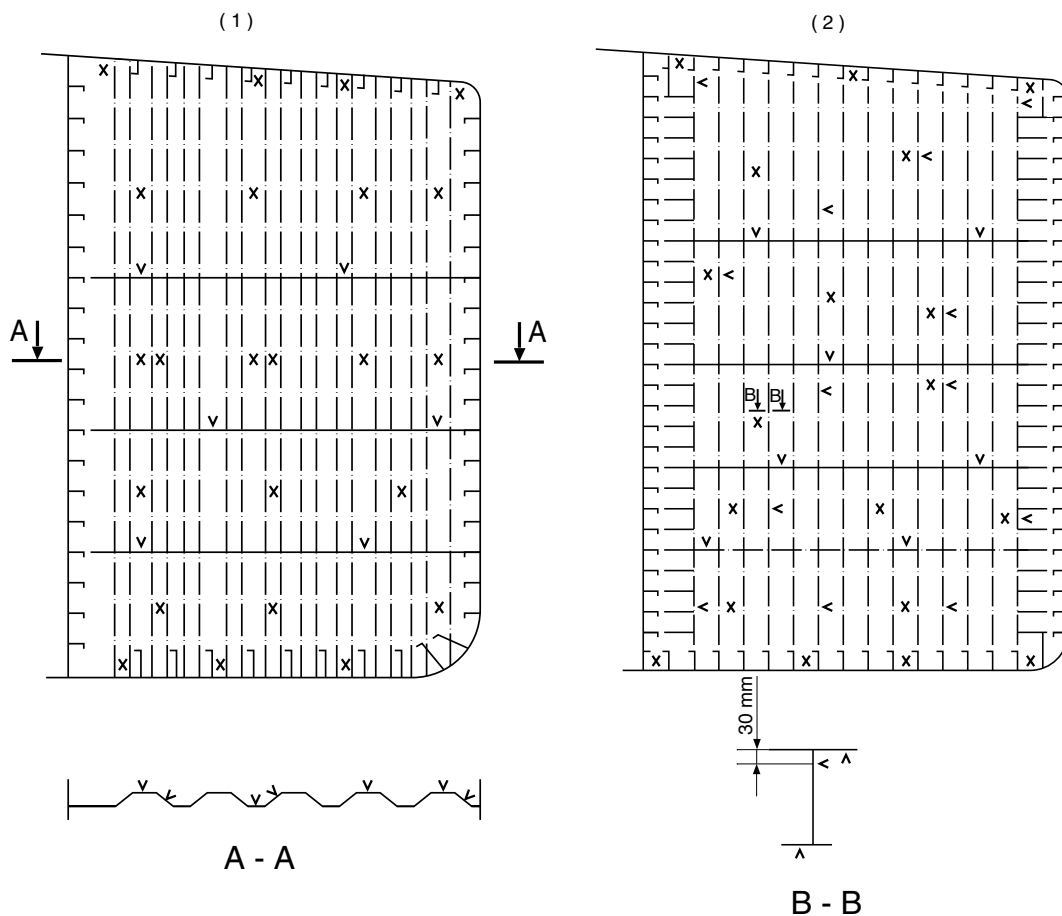


Figure 14 : Locations of measurements on transverse bulkheads of oil tankers



(1) : Corrugated bulkhead

(2) : Plane bulkhead

Measurements are to be taken in a similar way on the centre tank bulkheads

Measurements are to cover the different thicknesses of strakes over the height of the bulkhead

Measurements are to be taken of the adjacent structural members

Figure 15 : Location of measurements on transverse section of CSR oil tankers

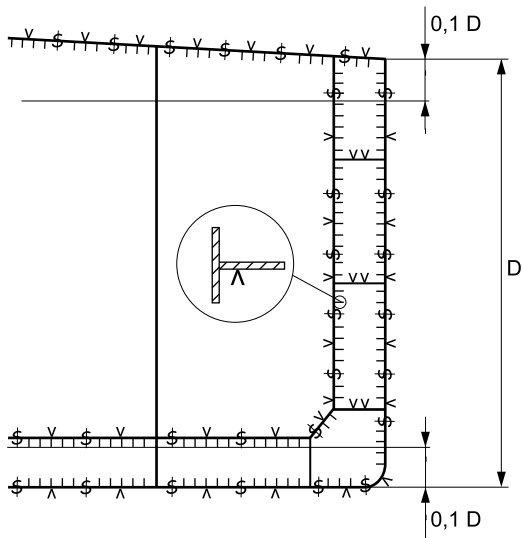


Figure 16 : Location of measurements on transverse rings in cargo and ballast tanks of CSR oil tankers

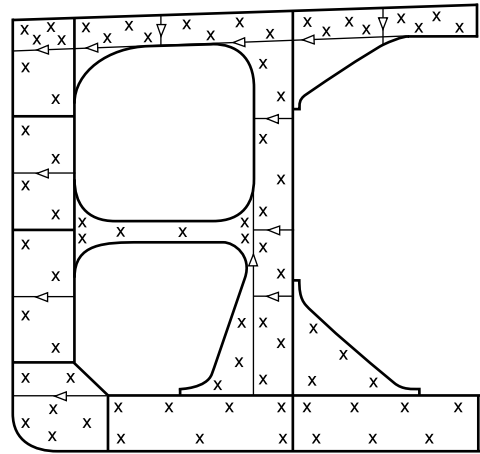


Figure 17 : Location of measurements on transverse bulkheads in cargo tanks of CSR oil tankers

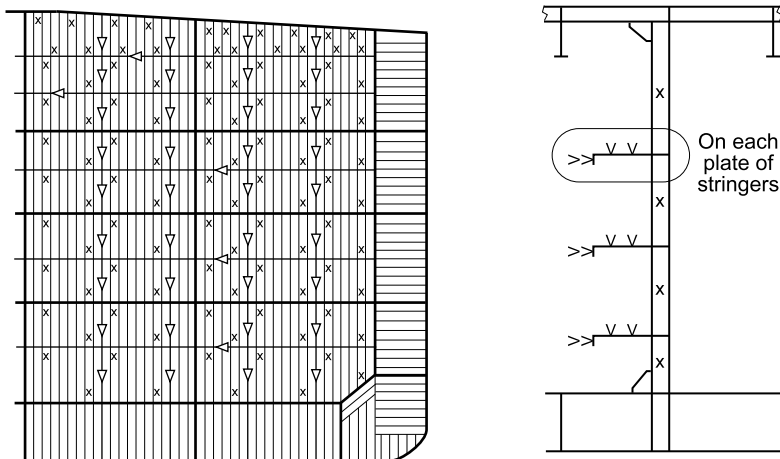
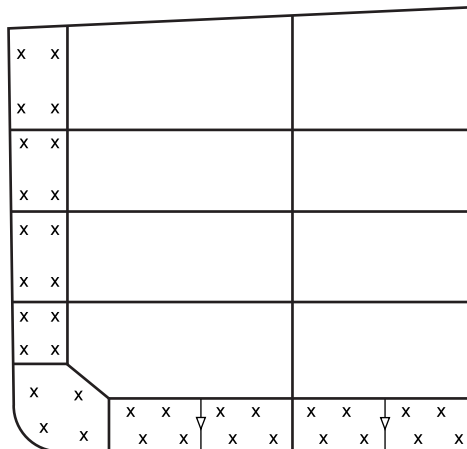


Figure 18 : Location of measurements on transverse bulkheads in ballast tanks of CSR oil tankers



4 Acceptance criteria for thickness measurements

4.1 General

4.1.1 Acceptance criteria stipulate limits of wastage which are to be taken into account for reinforcements, repairs or renewals of steel structure. These limits are generally expressed for each structural item as a maximum percentage of acceptable wastage (W). When the maximum percentage of wastage is indicated, the minimum acceptable thickness (t_{\min}) is that resulting from applying this percentage to the rule thickness (t_{rule}), according to the following formula:

$$t_{\min} = \left(1 - \frac{W}{100}\right) t_{\text{rule}}$$

However, when the rule thickness is not available, the as-built thickness can be used.

Only for criteria related to an item (see [4.3.4] b), the Society may establish a list of renewal thicknesses tailored to the different structural items. In such a case these thicknesses are used in lieu of the minimum thicknesses calculated from the percentage of wastage.

Note 1: In any case, at the request of the Owner, the Society may perform a direct calculation based on the current measurements.

4.1.2 In cases where the ship has some structural elements with reduced wear margins (e.g. due to ship conversion, increase of draught), the minimum acceptable thickness for these elements is to be calculated with reference to the rule scantlings without taking account of any reduction originally agreed.

4.1.3 Decisions on steel renewals are taken by the attending Surveyor applying the criteria given in this Article and based on his judgment and the actual condition of the ship. Should advice be needed to support his decision, the Surveyor may refer to the relevant technical office of the Society.

4.2 Criteria

4.2.1 The acceptance criteria for the minimum thicknesses are divided into:

- criteria on local and global strength, given in [4.3]
- criteria on buckling strength, given in [4.4]
- criteria on pitting, given in [4.5]
- criteria on hull supporting structure of shipboard fittings associated with towing and mooring, given in [4.6]
- criteria on ice strengthened structures for ships assigned with additional class notation for navigation in polar waters, given in [4.7]
- criteria on CSR ships, given in [4.8]
- criteria on container ships with a length greater than 65 m and contracted for construction on or after 1st July 2016, given in [4.9].

4.2.2 Each measured structural item is to be checked against above criteria, as far as applicable. When the criteria are not met, reinforcements, repairs and renewals are to be carried out as appropriate.

4.3 Local and global strength criteria

4.3.1 Local and global strength criteria are given for the following ship types:

- general cargo ships
- bulk carriers
- oil tankers.

These criteria may also be used for other ship types taking into consideration the equivalence or similarity of structural elements and their contribution to local and/or global strength.

4.3.2 For the evaluation of the ship longitudinal strength, it is a prerequisite that fillet welding between longitudinal members and deck, side and bottom plating is maintained effective so as to keep continuity of hull structures.

4.3.3 Each structural item to be assessed is illustrated in a typical transverse section (see Fig 19 for general cargo ships, Fig 20 for bulk carriers, Fig 21 for oil tankers).

These structural items are also listed in a table (Tab 3 for general cargo ships, Tab 4 for bulk carriers, Tab 5 for oil tankers) grouped according to their position and contribution to the local or global strength of the ship.

4.3.4 Each structural item is to be assessed according to four different criteria which vary with regard to the domain under which it is considered, namely:

- a) an isolated area, which is meant as a part of a single structural item. This criterion takes into consideration very local aspects such as grooving of a plate or web, or local severe corrosion; however, it is not to be used for pitting for which separate criteria are considered (see [4.5])
- b) an item, which is meant as an individual element such as a plate, a stiffener, a web, etc. This criterion takes into consideration the average condition of the item, which is assessed by determining its average thickness using the various measurements taken on the same item
- c) a group of items, which is meant as a set of elements of the same nature (plates, longitudinals, girders) contributing either to the longitudinal global strength of the ship in a given zone or to the global strength of other primary transverse elements not contributing to the ship longitudinal strength, e. g. bulkheads, hatch covers, web frames
- d) a zone, which is meant as all and only longitudinal elements contributing to the longitudinal strength of the ship; in this regard, the three main zones are defined as deck zone, neutral axis zone and bottom zone. This criterion takes into consideration the average condition of all groups of items belonging to the same zone.

Figure 19 : General cargo ship: layout of items to be assessed

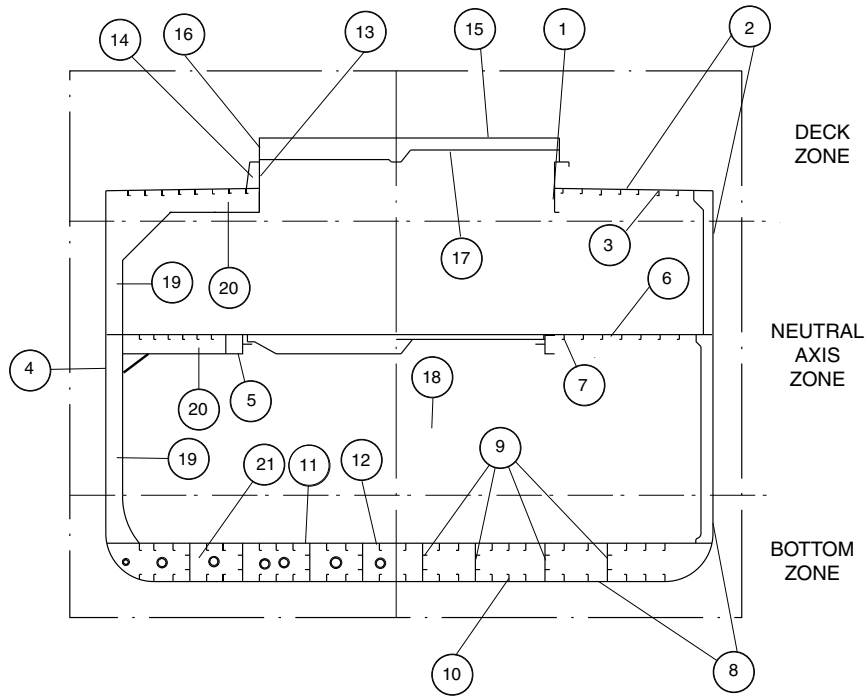


Figure 20 : Bulk carrier: layout of items to be assessed

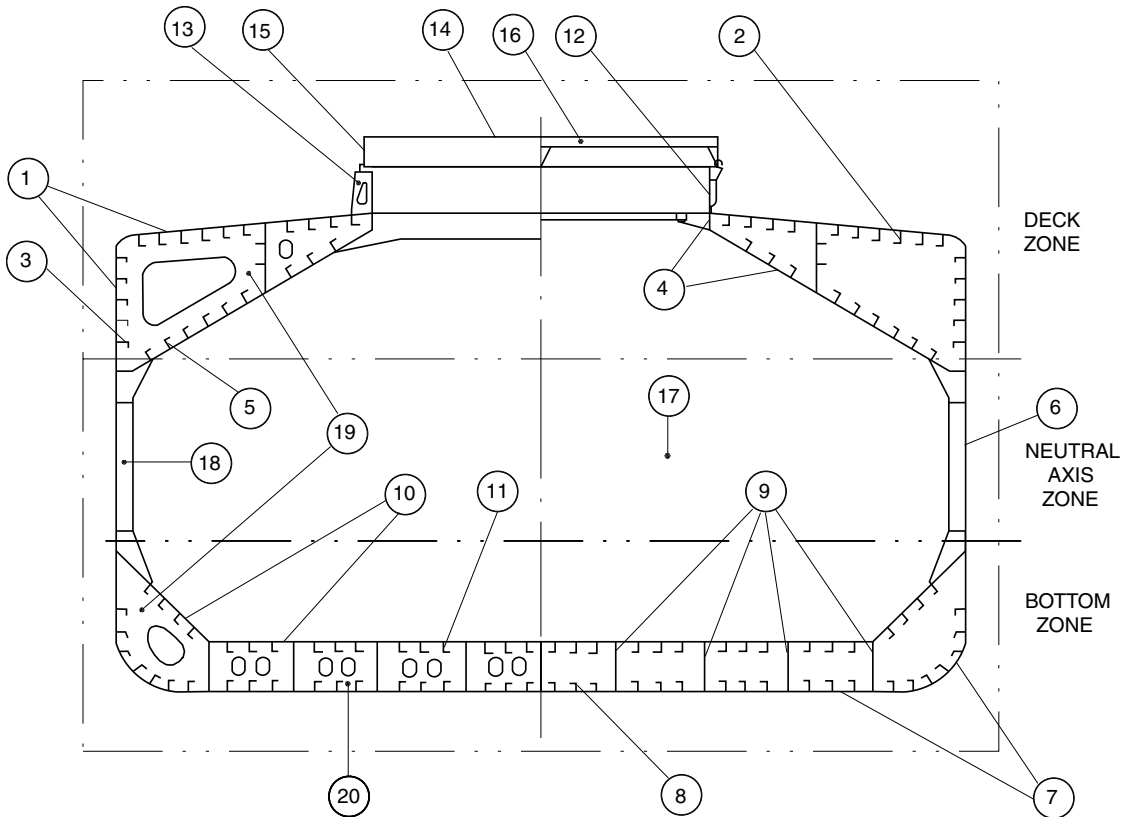


Figure 21 : Oil tanker: layout of items to be assessed

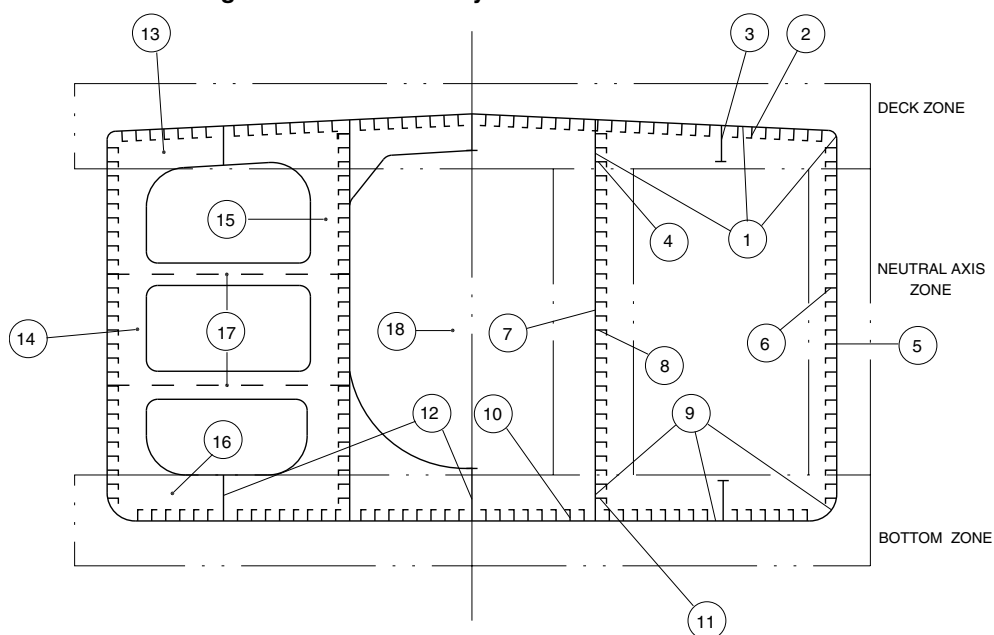


Table 3 : Local and global acceptance criteria for general cargo ships (given in % of wastage)

Group of items	Description of items	1 Isolated area	2 Item	3 Group	4 Zone
ITEMS CONTRIBUTING TO THE LONGITUDINAL STRENGTH (TRANSVERSE SECTION)					
DECK ZONE (1)		–	–	–	10
1	Hatch coaming	–	–	10	–
	underdeck girder web	25	20	–	–
	underdeck girder flange	20	15	–	–
2	Upperdeck plating, deck stringer plates and sheer strakes	30	20	10	–
3	Deck longitudinals	–	–	10	–
	web	30	20	–	–
	flange	25	15	–	–
NEUTRAL AXIS ZONE (1)		–	–	–	15
4	Side shell plating	25	20	15	–
5	‘Tweendeck hatch girder	–	–	15	–
	web	25	20	–	–
	flange	20	15	–	–
6	‘Tweendeck plating	30	20	15	–
7	‘Tweendeck longitudinals	–	–	15	–
	web	30	20	–	–
	flange	25	15	–	–
BOTTOM ZONE (1)		–	–	–	10
8	Bilge and bottom strakes and keel plate	25	20	10	–
9	Bottom girders	25	20	10	–
10	Bilge and bottom longitudinals	–	–	10	–
	web	30	20	–	–
	flange	25	15	–	–
11	Inner bottom plating	30	20	10	–
12	Inner bottom longitudinals	–	–	10	–
	web	30	20	–	–
	flange	25	15	–	–

Group of items	Description of items	1 Isolated area	2 Item	3 Group	4 Zone
OTHER ITEMS					
13	Hatch coaming plating (2)	25	20	–	–
14	Hatch coaming brackets	30	25	–	–
15	Hatch cover top plating (4)	25	20	15	–
16	Hatch cover skirt plating (4)	30	20	–	–
17	Hatch cover stiffeners (4)	30	20	–	–
18	Transverse bulkheads (3) (5) plating	30	20	15	–
	stringer web	30	20	–	–
	stringer flange	25	15	–	–
	stiffener web	30	20	–	–
	stiffener flange	25	15	–	–
	brackets	30	20	–	–
19	Side frames web	30	20	–	–
	flange	25	15	–	–
	brackets	30	20	–	–
20	Deck/tweendeck beams web	30	20	–	–
	flange	25	15	–	–
21	Floors plating	30	20	–	–
22	Forward and aft peak bulkheads plating	30	20	15	–
	stiffener web	30	20	–	–
	stiffener flange	25	15	–	–

(1) Each zone is to be evaluated separately.

(2) If continuous, to be included in item 1.

(3) For deep tank bulkheads, the values “average of item” and “average of group” are to be increased by 5 (%).

(4) For cargo ships constructed (i.e. keel laid) from 1st January 2012:

- steel renewal is required where the gauged thickness is less than $(t_{net} + 0,5)$ mm for: single skin hatch covers, plating of double skin hatch covers, and coaming structures the corrosion additions t_c of which are provided in Pt B, Ch 8, Sec 7, Tab 1 (for ships contracted for construction on or after 1st July 2016).
- where the gauged thickness is within the range $(t_{net} + 0,5)$ mm and $(t_{net} + 1,0)$ mm, coating (applied in accordance with the coating manufacturer’s requirements) or annual gauging may be adopted as an alternative to steel renewal. Coating is to be maintained in GOOD condition. If t_{net} is not available, the as-built thickness minus the total corrosion addition can be used.
- for the internal structures of double skin hatch covers, thickness gauging is required when hatch cover top or bottom plating renewal is to be carried out or when this is deemed necessary, at the discretion of the Surveyor, on the basis of the plating corrosion or deformation condition. In these cases, steel renewal for the internal structures is required when the gauged thickness is less than t_{net} . If t_{net} is not available, the as-built thickness minus the total corrosion addition can be used.
- for corrosion addition $t_c = 1,0$ mm the thickness for steel renewal is t_{net} and the thickness for coating or annual gauging is when gauged thickness is between t_{net} and $(t_{net} + 0,5)$ mm.
- for coaming structures, the corrosion addition t_c of which are not provided in Pt B, Ch 8, Sec 7, Tab 1, steel renewal and coating or annual gauging are to be in accordance with the requirements of the Society (for ships contracted for construction on or after 1st July 2016).

For cargo ships constructed (i.e. keel laid) from 1st January 2005:

- for hatch covers in way of cellular cargo holds intended for containers (plating, stiffeners and internals), steel renewal is required where the gauged thickness is less than t_{net} . Where the gauged thickness is within the range t_{net} and $(t_{net} + 0,5)$ mm, coating (applied in accordance with the coating manufacturer’s requirements) or annual gauging may be adopted as an alternative to steel renewal. Coating is to be maintained in good condition. If t_{net} is not available, the as-built thickness minus the total corrosion addition can be used.

(5) For ships indicated in Pt D, Ch 4, Sec 3, [6.1.1], contracted for construction on or after 1 July 2006, vertically corrugated transverse bulkheads are to be repaired by steel renewal where the gauged thickness is less than $(t_{net} + 0,5)$ mm, where t_{net} is the thickness obtained by applying the strength criteria given in Pt D, Ch 4, Sec 3, [6.1]. However, where the gauged thickness is within the range $(t_{net} + 0,5)$ mm and $(t_{net} + 1,0)$ mm, coating (applied in accordance with the coating Manufacturer’s requirements) or annual gauging may be adopted as an alternative to steel renewal.

Table 4 : Local and global acceptance criteria for bulk carriers (given in % of wastage)

Group of items	Description of items	1 Isolated area	2 Item	3 Group	4 Zone
ITEMS CONTRIBUTING TO THE LONGITUDINAL STRENGTH (TRANSVERSE SECTION)					
DECK ZONE (1)		–	–	–	10
1	Strength deck plating, deck stringer, sheer strake and part of side shell plating in way of top side tanks	25	20	10	–
2	Deck longitudinals web flange	– 25 20	– 20 15	10 – –	– – –
3	Side shell longitudinals in way of top side tanks web flange	– 25 20	– 20 15	10 – –	– – –
4	Top side tank sloped plating, including horizontal and vertical strakes	25	20	10	–
5	Longitudinals connected to top side tank sloped plating web flange	– 25 20	– 20 15	10 – –	– – –
NEUTRAL AXIS ZONE (1)		–	–	–	15
6	Side shell plating	25	20	15	–
BOTTOM ZONE (1)		–	–	–	10
7	Bilge and bottom plating and keel plate	25	20	10	–
8	Bilge and bottom longitudinals web flange	– 25 20	– 20 15	10 – –	– – –
9	Bottom girders	25	15	10	–
10	Inner bottom plating and hopper tank sloped plating	25	20	10	–
11	Longitudinals connected to inner bottom and hopper tank sloped plating web flange	– 25 20	– 20 15	10 – –	– – –
OTHER ITEMS					
12	Hatch coaming plating (2) (6)	25	20	–	–
13	Hatch coaming brackets (6)	30	25	–	–
14	Hatch cover top plating (5) (6)	25	20	15	–
15	Hatch cover skirt plating (5) (6)	25	20	–	–
16	Hatch cover stiffeners (5) (6)	25	20	–	–
17	Transverse bulkheads (3) plating stiffener web stiffener flange	25 25 20	20 20 15	15 – –	– – –
18	Side shell frames (4) web flange brackets	25 20 20	20 15 15	– – –	– – –
19	Topside and hopper tank web frames web flange	25 20	20 15	– –	– –
20	Floors plating	25	15	–	–

Group of items	Description of items	1 Isolated area	2 Item	3 Group	4 Zone
21	Forward and aft peak bulkheads plating stiffener web stiffener flange	25 25 20	20 20 15	15 – –	– – –
<p>(1) Each zone is to be evaluated separately.</p> <p>(2) If continuous, to be included in item 1.</p> <p>(3) For vertically corrugated transverse bulkheads in cargo holds:</p> <ul style="list-style-type: none"> For ships indicated in Ch 6, Sec 2, [1.1] which are to comply with the retroactive requirements according to the schedule given in Ch 6, Sec 2, [1.2], the bulkhead between the two foremost cargo holds is to be assessed based on the criteria given in Ch 6, Sec 2, [1.3]. For ships indicated in Pt D, Ch 4, Sec 3, [6.1.1], contracted for construction on or after 1 July 1998, all bulkheads are to be repaired by steel renewal where the gauged thickness is less than $(t_{net} + 0,5)$ mm, where t_{net} is the thickness obtained by applying the strength criteria given in Pt D, Ch 4, Sec 3, [6.1]. However, where the gauged thickness is within the range $(t_{net} + 0,5)$ mm and $(t_{net} + 1,0)$ mm, coating (applied in accordance with the coating Manufacturer's requirements) or annual gauging may be adopted as an alternative to steel renewal. <p>(4) Steel renewal criteria or other measures (reinforcement or coating) to be taken for the side shell frames and brackets in single side skin ships with service notation bulk carrier ESP not built in accordance with Part II, Chapter 08, Section 8-03 of the 1st April 1998 edition of the Rules or subsequent editions are given in Ch 6, Sec 2, [5] and Ch 6, App 1, [5]. However, for such ships which are to comply with Ch 6, Sec 2, [5], the thickness measurements of flanges and side shell plating not covered in Ch 6, Sec 2, [5.3], as well as the thickness measurements of additional intermediate frames fitted for reinforcement in order to comply with an ice class notation (ice strengthening structure), are to be carried out in accordance with Article [3] and the measured thicknesses assessed against the criteria indicated in Article [4] and the present Table.</p> <p>(5) For ships which are assigned one of the service notations bulk carrier ESP, bulk carrier BC-A ESP, bulk carrier BC-B ESP or bulk carrier BC-C ESP, contracted for construction on or after the 1st July 1998 and for hatch covers on exposed decks:</p> <ul style="list-style-type: none"> for single skin hatch covers and for the plating of double skin hatch covers, steel renewal is required where the gauged thickness is less than $(t_{net} + 0,5)$ mm. Where the gauged thickness is within the range $(t_{net} + 0,5)$ mm and $(t_{net} + 1,0)$ mm, coating (applied in accordance with the coating manufacturer's requirements) or annual gauging may be adopted as an alternative to steel renewal. If t_{net} is not available, the as-built thickness, minus the total corrosion addition, can be used. for the internal structures of double skin hatch covers, thickness gauging is required when plating renewal is to be carried out or when this is deemed necessary, at the discretion of the Society's Surveyor, on the basis of the plating corrosion or deformation condition. In these cases, steel renewal for the internal structures is required where the gauged thickness is less than t_{net}. If t_{net} is not available, the as-built thickness, minus the total corrosion addition, can be used. <p>(6) For ships which are assigned one of the service notations bulk carrier BC-A ESP, bulk carrier BC-B ESP, bulk carrier BC-C ESP, ore carrier ESP, combination carrier/OBO ESP or combination carrier/OOC ESP, contracted for construction on or after 1 January 2004 and for all cargo hatch covers and hatch forward and side coamings on exposed decks in position 1 as defined in ILLC:</p> <ul style="list-style-type: none"> for single skin hatch covers and for the plating of double skin hatch covers, steel renewal is required where the gauged thickness is less than $(t_{net} + 0,5)$ mm. Where the gauged thickness is within the range $(t_{net} + 0,5)$ mm and $(t_{net} + 1,0)$ mm, coating (applied in accordance with the coating manufacturer's requirements) or annual gauging may be adopted as an alternative to steel renewal. Coating is to be maintained in good condition. If t_{net} is not available, the as-built thickness, minus the total corrosion addition, can be used. for the internal structures of double skin hatch covers, thickness gauging is required when plating renewal is to be carried out or when this is deemed necessary, at the discretion of the Society's Surveyor, on the basis of the plating corrosion or deformation condition. In these cases, steel renewal for the internal structures is required where the gauged thickness is less than t_{net}. If t_{net} is not available, the as-built thickness, minus the total corrosion addition, can be used. for hatch coamings, steel renewal is required where the gauged thickness is less than $(t_{net} + 0,5)$ mm. Where the gauged thickness is within the range $(t_{net} + 0,5)$ mm and $(t_{net} + 1,00)$ mm, coating (applied in accordance with the coating manufacturer's requirements) or annual gauging may be adopted as an alternative to steel renewal. Coating is to be maintained in good condition. If t_{net} is not available, the as-built thickness, minus the total corrosion addition, can be used. 					

Table 5 : Local and global acceptance criteria for oil tankers (given in % of wastage)

Group of items	Description of items	1 Isolated area	2 Item	3 Group	4 Zone
ITEMS CONTRIBUTING TO THE LONGITUDINAL STRENGTH (TRANSVERSE SECTION)					
DECK ZONE (1)					
1	Deck plating, deck stringer, sheer strake and longitudinal bulkhead upper strake (2)	25	20	10	–
2	Deck and sheer strake longitudinals web flange	– 25 20	– 20 15	10 – –	– – –
3	Deck longitudinal girders web flange	– 25 20	– 20 15	10 – –	– – –

Group of items	Description of items	1 Isolated area	2 Item	3 Group	4 Zone
4	Longitudinals connected to longitudinal bulkhead upper strake (2) web flange	–	–	10	–
		25	20	–	–
		20	15	–	–
NEUTRAL AXIS ZONE (1)		–	–	–	15
5	Side shell plating (2)	25	20	15	–
6	Side shell longitudinals and stringers (2) web flange	–	–	15	–
		25	20	–	–
		20	15	–	–
7	Longitudinal bulkhead plating	25	20	15	–
8	Longitudinal bulkhead longitudinals and stringers web flange	–	–	15	–
		25	20	–	–
		20	15	–	–
BOTTOM ZONE (1)		–	–	–	10
9	Bilge and bottom strakes, longitudinal bulkhead lower strake and keel plate (2)	25	20	10	–
10	Bilge and bottom longitudinals (2) web flange	–	–	10	–
		25	20	–	–
		20	15	–	–
11	Longitudinals connected to longitudinal bulkhead lower strake web flange	–	–	10	–
		25	20	–	–
		20	15	–	–
12	Bottom girders web flange	–	–	10	–
		25	20	–	–
		20	15	–	–
OTHER ITEMS					
13	Deck transverse web frame web flange brackets / stiffeners	25	20	–	–
		20	15	–	–
		25	20	–	–
14	Side shell web frame web flange brackets / stiffeners	25	20	–	–
		20	15	–	–
		25	20	–	–
15	Longitudinal bulkhead web frame web flange brackets / stiffeners	25	20	–	–
		20	15	–	–
		25	20	–	–
16	Bottom transverse web frame web flange brackets / stiffeners	25	20	–	–
		20	15	–	–
		25	20	–	–
17	Cross tie web flange brackets / stiffeners	25	15	–	–
		20	15	–	–
		20	15	–	–
18	Transverse bulkheads (3) plating stringer web stringer flange stiffener web stiffener flange	25	20	15	–
		25	20	–	–
		20	15	–	–
		30	20	–	–
		25	15	–	–
<p>(1) Each zone is to be evaluated separately.</p> <p>(2) For double hull oil tankers, the structural elements of the inner skin (plating, longitudinals, girders, bulkheads) are to be included in the corresponding elements of the outer skin.</p> <p>(3) Including swash bulkheads, forward and aft peak bulkheads.</p>					

4.3.5 The assessment of the thickness measurements is to be performed using the values given in the tables for each structural element with regard to the four criteria defined above, in the following order:

- a) assessment of isolated areas (column 1 in the tables). If the criterion is not met, the wasted part of the item is to be dealt with as necessary.
- b) assessment of items (column 2 in the tables). If the criterion is not met, the item is to be dealt with as necessary in the measured areas as far as the average condition of the item concerned is satisfactory. In cases where some items are renewed, the average thicknesses of these items to be considered in the next step are the new thicknesses.
- c) assessment of groups of items (column 3 in the tables). If the criterion is not met, a sufficient number of elements are to be renewed in order to obtain an increased average thickness satisfying the considered criterion of the group (generally the elements to be renewed are those most wasted). As an example, for the assessment of the group “deck plates” all deck plates are measured and an average thickness of each of them is estimated. Then the average of all these values is to satisfy the criteria given for this group.
- d) assessment of zones (column 4 in the tables). In principle, the criterion of the zone is met when all groups of items belonging to the zone meet their own criteria (see c) above). However, a greater diminution than those given in column 3 may be accepted for one group of items if, considering the other groups of items belonging to the same zone, the overall diminution of the zone does not exceed the criterion given for it in column 4.

Example: The deck zone consists of two groups of items:

- deck plating, which has an average diminution of 12% (criterion 10%)
- deck longitudinals, which has an average diminution of 4% (criterion 10%).

Even though the deck plating group exceeds its acceptance criterion, the average diminution of the zone, which can be very roughly estimated at 8%, is acceptable and thus the deck plating group can be accepted as it is.

Note 1: This criterion applicable to the zones is based on the general rule that the current hull girder section modulus is not to be less than 90% of the rule section modulus within 0,4L amidships. When the zone criterion is used, the assessment is made on the basis of the original modulus instead of the rule modulus. At the request of the Owner, a direct calculation using the ship’s current thicknesses may be performed by the Society in order to accept greater diminutions than those given for this criterion.

4.3.6 These criteria take into consideration two main aspects:

- the overall strength of the hull girder
- the local strength and integrity of the hull structure, such as hatch covers, bulkheads, etc.

As a rule, they are applicable to the structure within the cargo area of ships having a length greater than 90 metres. However, they may also be used for smaller ships and for structure outside the cargo area according to the following principles:

- for ships having a length less than 90 metres, the percentages of acceptable wastage given in the tables can be increased by 5 (%) (e.g. 15% instead of 10%, etc.), except for those of deck and bottom zones
- for structure outside the cargo area, the same 5 (%) increase can be applied,

on the understanding, however, that both conditions cannot be applied at the same time.

4.4 Buckling strength criterion

4.4.1 This criterion is applicable to ships having a length greater than 120 metres.

The structural items contributing to the longitudinal strength of the ship, such as deck and bottom plating, deck and bottom girders, etc., are to be assessed with regard to their buckling strength, as deemed necessary by the Surveyor. In such a case, the values shown in Tab 6 are not to be exceeded.

Note 1: The minimum thickness will be specially considered for ships built with excess hull girder section modulus.

Table 6 : Buckling strength criterion

Items		Ratio	Material (R_{eH})		
			235	315	355 and 390
Bottom and deck plates		s / t	56,0	51,0	49,0
Longitudinals	flat bar web	h_w / t_w	20,0	18,0	17,5
Flanged longitudinals / girders	web	h_w / t_w	56,0	51,0	49,0
	symmetrical flange	b_f / t_f	34,0	30,0	29,0
	asymmetrical flange	b_f / t_f	17,0	15,0	14,5
Symbols:					
R_{eH} : Minimum yield stress of the material, in N/mm ² ; s : Longitudinal spacing, in mm; t : Actual plate thickness, in mm; h_w : Web height, in mm; t_w : Web thickness, in mm; b_f : Flange breadth, in mm; t_f : Flange thickness, in mm.					

4.5 Pitting

4.5.1 The maximum acceptable depth for isolated pits is 35% of the as-built thickness.

4.5.2 For areas with different pitting intensity, the intensity diagrams shown in Fig 22 are to be used to identify the percentage of affected areas.

For areas having a pitting intensity of 50% or more, the maximum average depth of pits is 20% of the as-built thickness. For intermediate values between isolated pits and 50% of affected area, the interpolation between 35% and 20% is made according to Tab 7.

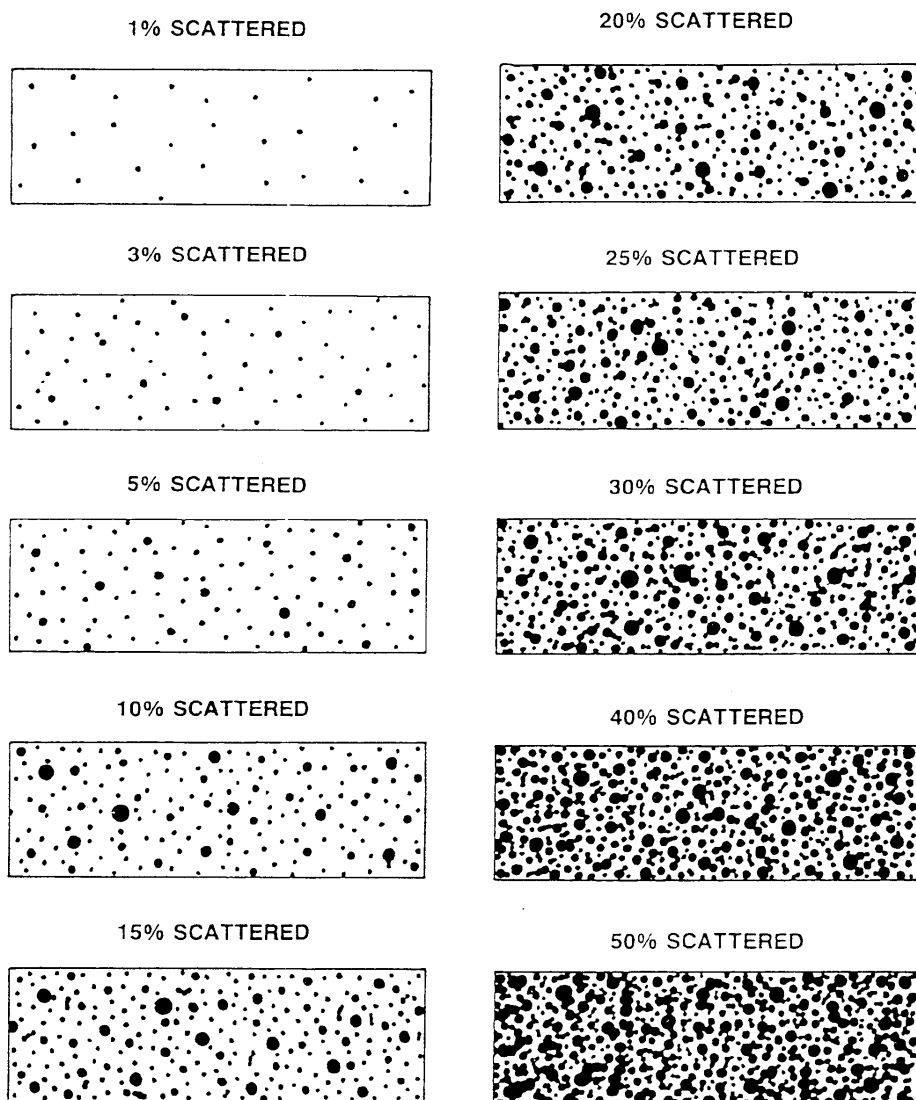
4.5.3 In addition, the thickness outside the pits in the area considered is to be assessed according to [4.3] and [4.4].

Note 1: Application of filler material (plastic or epoxy compounds) is recommended as a means to stop or reduce the corrosion process, but it is not considered an acceptable repair for pitting exceeding the maximum allowable wastage limits. Welding repairs may be accepted when performed in accordance with procedures agreed with the society.

Table 7 : Pitting intensity and corresponding maximum average depth of pitting

Pitting Intensity, (%)	Maximum average pitting depth, (% of the as-built thickness)
Isolated	35,0
5	33,5
10	32,0
15	30,5
20	29,0
25	27,5
30	26,0
40	23,0
50	20,0

Figure 22 : Pitting intensity diagrams (from 1% to 50% intensity)



4.6 Hull supporting structure of shipboard fittings associated with towing and mooring

4.6.1 For ships contracted for construction on or after the 1st January 2007, the allowable wastage of the hull supporting structure of shipboard fittings associated with towing and mooring is not to exceed:

- the total corrosion addition defined in NR522 or NR523 for ships covered by the Common Structural Rules for Bulk Carriers or the Common Structural Rules for Double Hull Oil Tankers, or
- 2,0 mm for other ships.

4.7 Ice strengthened structures for ships assigned with additional class notation for navigation in polar waters

4.7.1 For ships assigned with one of the additional class notations **POLAR CLASS** as defined in Ch 1, Sec 2, [6.11], steel renewal for ice strengthened structures as defined in NR527 is required when the gauged thickness is less than $t_{net} + 0,5$ mm.

4.8 Acceptance criteria for CSR ships

4.8.1 General

For ships built under the Common Structural Rules, the acceptance criteria are according to the following rules:

- Chapter 13, "Ships in Operation, Renewal Criteria", of NR522 CSR for Bulk Carriers
- Section 12, "Ship in Operation Renewal Criteria", of NR523 CSR for Double Hull Oil Tankers,

and as specified in [4.8.2], [4.8.3], [4.8.4] and [4.8.5].

For ships built under the Common Structural Rules and complying with the requirements of Rule Note NR606 Common Structural Rules for Bulk Carriers and Oil Tankers, the acceptance criteria are to be in accordance with Part 1, Chapter 13, "Ship in Operation - Renewal Criteria", of this NR606.

4.8.2 Pitting corrosion: side structures (CSR bulk carriers)

If pitting intensity, in an area where coating is required according to NR522 CSR for Bulk Carriers Ch 3, Sec 5, or NR606 CSR for Bulk Carriers and Oil Tankers Part 1, Ch 3, Sec 4, as applicable, is higher than 15% (see Fig 22), thickness measurements are to be performed to check the extent of pitting corrosion. The 15% is based on pitting or grooving on only one side of a plate. In cases where pitting is exceeding 15%, as defined above, an area of 300 mm or more, at the most pitted part of the plate, is to be cleaned to bare metal and the thickness is to be measured in way of the five deepest pits within the cleaned area. The least thickness measured in way of any of these pits is to be taken as the thickness to be recorded. The minimum remaining thickness in pits, grooves or other local areas is to be greater than the following values:

- for CSR single and double skin bulk carriers: 70% of the as-built thickness, in the side shell, hopper tank and top-side tank plating attached to the each side frame, over a width up to 30 mm on either side of it
- for CSR single skin bulk carriers: 75% of the as-built thickness, in the frame and end bracket webs and flanges,

without being greater than the renewal thickness t_{ren} as defined in [4.8.3].

4.8.3 Pitting corrosion: other structures (CSR bulk carriers and CSR oil tankers)

For plates with pitting intensity less than 20% (see Fig 22), the measured thickness t_m , in mm, of any individual measurement is to meet the lesser of the following criteria:

$$t_m \geq 0,7 (t_{as-built} - t_{vol add})$$

$$t_m \geq t_{ren} - 1,0$$

where:

$t_{as-built}$: As-built thickness of the member, in mm

$t_{vol add}$: Voluntary thickness addition, namely thickness, in mm, voluntarily added as the Owner's extra margin for corrosion wastage in addition to t_c

t_{ren} : Renewal thickness, namely minimum allowable thickness, in mm, below which renewal of structural members is to be carried out (see also NR523 CSR for Double Hull Oil Tankers, Section 12) or NR606 CSR for Bulk Carriers and Oil Tankers, Part 1, Chapter 13, as applicable)

t_c : Total corrosion addition, in mm, defined in NR522 CSR for Bulk Carriers, Ch 3, Sec 3 or in NR606 CSR for Bulk Carriers and Oil Tankers, Pt 1, Ch 3, Sec 3, as applicable

t_m : Measured thickness, in mm, on one item, i.e. average thickness on one item using the various measurements taken on this same item during periodical ship's in service surveys.

The average thickness across any cross-section in the plating is not to be less than the renewal thickness for general corrosion given in NR522 CSR for Bulk Carriers, Chapter 13 or in NR523 CSR for Double Hull Oil Tankers, Section 12 or in NR606 CSR for Bulk Carriers and Oil Tankers, Part 1, Chapter 13, as applicable.

4.8.4 Edge corrosion of CSR ships

Provided that the overall corroded height of the edge corrosion of the flange, or web in the case of flat bar stiffeners, is less than 25% of the stiffener flange breadth or web height, as applicable (see Fig 23), the measured thickness t_m , in mm, is to meet the lesser of the following criteria:

$$t_m \geq 0,7 (t_{as-built} - t_{vol add})$$

$$t_m \geq t_{ren} - 1,0$$

where:

$t_{as-built}$, $t_{vol add}$, t_{ren} : As defined in [4.8.3].

The average measured thickness t_m across the breadth or height of the stiffener is not to be less than the one defined in NR522 CSR for Bulk Carriers, Chapter 13 or in NR523 CSR for Double Hull Oil Tankers, Section 12 or in NR606 CSR for Bulk Carriers and Oil Tankers, Part 1, Chapter 13, as applicable.

Figure 23 : Edge corrosion

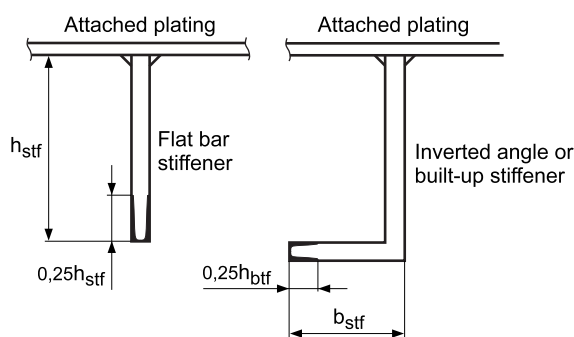


Plate edges at openings for manholes, lightening holes, etc... may be below the minimum thickness given in NR522 CSR for Bulk Carriers, Chapter 13 or in NR523 CSR for Double Hull Oil Tankers, Section 12, or in NR606 CSR for Bulk Carriers and Oil Tankers, Part 1, Chapter 13, as applicable, provided that:

- The maximum extent of the reduced plate thickness, below the minimum given in NR522 CSR for Bulk Carriers, Chapter 13 or in NR523 CSR for Double Hull Oil Tankers, Section 12 or in NR606 CSR for Bulk Carriers and Oil Tankers, Part 1, Chapter 13, as applicable, from the opening edge is not more than 20% of the smallest dimension of the opening and does not exceed 100 mm.
- rough or uneven edges may be cropped-back provided that the maximum dimension of the opening is not increased by more than 10% and the remaining thickness of the new edge is not less than $t_{ren} - 1$ mm.

4.8.5 Acceptance criteria for grooving corrosion of CSR ships

- Where the groove breadth is a maximum of 15% of the web height but not more than 30 mm (see Fig 24), the measured thickness t_m , in mm, in the grooved area is to meet the lesser of the following criteria:

$$t_m \geq 0,75 (t_{as-built} - t_{vol-add})$$

$$t_m \geq t_{ren} - 0,5$$

but is not to be less than:

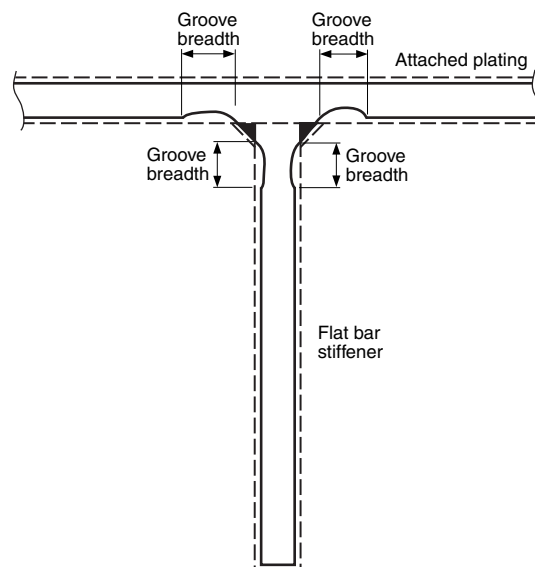
$$t_m = 6 \text{ mm},$$

where:

$t_{as-built}$, $t_{vol-add}$, t_{ren} : As defined in [4.8.3].

- Structural members with areas of grooving greater than those in item a) are to be assessed, based on the criteria for general corrosion as defined in NR522 CSR for Bulk Carriers, Chapter 13 or in NR523 CSR for Double Hull Oil Tankers, Section 12 or in NR606 CSR for Bulk Carriers and Oil Tankers, Part 1, Chapter 13, as applicable, using the average measured thickness across the plating/stiffener.

Figure 24 : Grooving corrosion



4.9 Acceptance criteria for container ships

4.9.1 General

For ships assigned with the service notation **container ship**, contracted for construction on or after the 1st July 2016 and with a length greater than 65 m, the acceptance criteria for allowable thickness diminution of ship hull structure are given here after.

Symbols:

- $t_{as-built}$: As built thickness, in mm.
- t_c : Corrosion addition, in mm, as defined in Structural rules for container ships NR625, Ch 3, Sec 2.
- $t_{vol-add}$: Thickness for voluntary addition, in mm.
- t_m : Measured thickness, in mm, on one item, i.e. average thickness on one item using the various measurements taken on this same item during periodical ship's in service surveys.

4.9.2 Local corrosion

- Renewal thickness of local structural elements:
Local structural elements include local supporting members and primary supporting members.
Steel renewal is required if the measured thickness, t_m , in mm, is less than the renewal thickness, t_{ren} , defined as:
$$t_{ren} = t_{as-built} - t_c - t_{vol-add}$$
- Renewal area:
Areas which need to be renewed based on the renewal criteria in item a) are to be repaired with inserted material which is to have the same or greater grade and yield stress as the original, and to have a thickness, t_{repair} , in mm, not less than:
$$t_{repair} = t_{asbuilt} - t_{vol-add}$$
- Alternative solutions:
When there is a substantial corrosion as defined in Ch 2, Sec 2, [2.2.7], alternative solutions may be adopted in accordance with the requirements of the Society.

4.9.3 Global corrosion

a) Application:

The longitudinal strength of the ship is to be evaluated by using the thickness of structural members measured, renewed and reinforced, as appropriate, during class renewal surveys, for ships over 10 years of age.

b) Renewal criteria:

Hull girder strength criteria are given as detailed below:

- For deck and bottom zones:

The current hull girder section modulus at deck and bottom determined with the thickness measurements are not to be less than 90% of the section modulus calculated according to NR625, Ch 5, Sec 1 with the gross offered thickness.

Alternatively, the current sectional areas of the bottom zone and of the deck zone which are the sum of the measured item areas of the considered zones are not to be less than 90% of the sectional area of the corresponding zones determined with the gross offered thickness.

- For neutral axis zone:

The current sectional area of the neutral axis zone, which is the sum of the measured plating areas of this zone, is not to be less than the sectional area of the neutral axis zone calculated with the gross offered thickness minus $0,5 t_c$.

If the actual reduction of the gross offered thickness of all items, of a given transverse section which contribute to the hull girder strength is less than 10% for the deck and bottom zones and $0,5 t_c$ for the neutral axis zone, the hull girder strength criteria of this transverse section is satisfied and there is no need to perform calculation of the zone areas with measured thicknesses.

The gross offered thickness, t_{gr-off} , is the gross thickness provided at the newbuilding stage, which is obtained by deducting any thickness for voluntary addition from the as built thickness, as follows:

$$t_{gr-off} = t_{as-built} - t_{vol-add}$$

4.9.4 Pitting corrosion

The pitting depth is to be checked according to [4.5.1] and [4.5.2].

APPENDIX 4

CONDITION MONITORING AND CONDITION BASED MAINTENANCE

1 General

1.1 Application

1.1.1 These requirements apply to the approved Condition Monitoring and Condition Based Maintenance schemes where the condition monitoring results are used to influence the scope and/or frequency of Class survey.

1.1.2 This scheme may be applied to components and systems covered by continuous survey system for machinery (CSM), and other components and systems as requested by the owner. The extent of Condition Based Maintenance and associated monitoring equipment to be included in the maintenance scheme is decided by the Owner.

1.1.3 These requirements can be applied only to vessels operating on approved PMS survey scheme.

1.1.4 The scheme may be applied to any individual items and systems. Any items not covered by the scheme are to be surveyed and credited in accordance with the requirements of Part A, Chapter 3, Part A, Chapter 4 and Part A, Chapter 5 as applicable.

1.1.5 Ships complying with the requirements of this Appendix are granted one of the notations **CBM** or **[CBM]** as defined in Ch 1, Sec 2, [4.17.9].

1.2 Definitions

1.2.1 The following standard terms are defined in ISO 13372:2012.

1.2.2 Condition monitoring

Acquisition and processing of information and data that indicate the state of a machine over time. The machine state deteriorates if faults or failures occur.

1.2.3 Diagnostic

Examination of symptoms and syndromes to determine the nature of faults or failures.

1.2.4 Condition based maintenance

Maintenance performed as governed by condition monitoring programmes.

1.3 Condition monitoring (CM)

1.3.1 Where an approved condition monitoring system is fitted, credit for survey may be based on acceptable condition monitoring results. The condition monitoring results are to be reviewed during the annual audit.

1.3.2 Limiting parameters are to be based on the Original Equipment Manufacturers guidelines (OEM), or a recognised international standard.

1.3.3 The condition monitoring system is to provide an equivalent or greater degree of confidence in the condition of the machinery to traditional survey techniques.

1.3.4 The condition monitoring system is to be approved in accordance with the Society's procedures.

1.3.5 A condition monitoring system may be used to provide a greater understanding of equipment condition, and a condition based maintenance scheme may be used to obtain maintenance efficiency. Class approval is required where owners wish to change the survey cycle based on CM/CBM.

1.3.6 Software systems can use complex algorithms, machine learning and knowledge of global equipment populations/defect data in order to identify acceptability for continued service or the requirement for maintenance. These systems may be independent of the OEM recommended maintenance and condition monitoring suggested limits. Approval of this type of software is to be based on OEM recommendations, industry standards and Society experience.

1.3.7 The Society retains the right to test or open-up the machinery, irrespective of the CM results, if deemed necessary by Surveyor during annual and renewal audits.

1.4 Condition based maintenance (CBM)

1.4.1 Where an owner wishes to base their equipment maintenance on a CBM approach, this is to meet the requirements of the ISM Code.

1.4.2 Where an approved planned maintenance and CBM scheme is in operation, the CSM and other survey intervals may be extended based on OEM maintenance recommendations and acceptable condition monitoring results.

1.4.3 Limiting parameters (alarms and warnings) are to be based on the OEM guidelines, or a recognised international standard.

1.4.4 The CBM scheme is to provide an equivalent or greater degree of confidence in the condition of the machinery to traditional maintenance techniques.

1.4.5 The scheme is to be approved in accordance with the Society's procedures.

1.4.6 Software systems can use complex algorithms, machine learning and knowledge of global equipment populations/defect data in order to identify acceptability for continued service or the requirement for maintenance. These systems may be independent of the OEM recommended maintenance and condition monitoring suggested limits. Approval of this type of software is to be based on OEM recommendations, industry standards and Society experience. In that case, written agreement from the OEM is to be provided to the Society.

2 Procedures and conditions for approval of CM and CBM

2.1 Onboard responsibility

2.1.1 The Chief Engineer is to be the responsible person on board in charge of the CM and CBM.

2.1.2 Documentation on the overhaul of items covered by CM and CBM schemes are to be reported by the Chief Engineer.

2.1.3 Access to computerized systems for updating of the maintenance documentation and maintenance program is only to be permitted by the Chief Engineer or other authorized person.

2.1.4 All personnel involved in CM and CBM is to be appropriately qualified.

Note 1: CM does not replace routine surveillance or the Chief Engineer's responsibility for taking decisions in accordance with his judgement.

2.2 Equipment and systems requirements

2.2.1 CM equipment and systems are to be approved in accordance with the Rule Note NR674 Condition Monitoring Systems.

2.2.2 The CM/CBM scheme and its extent, are to be approved by the Society.

2.2.3 The CBM scheme is to be capable of producing a condition report, and maintenance recommendations.

2.2.4 A system is to be provided to identify where limiting parameters (alarms and warnings) are modified during the operation of the scheme.

2.2.5 Where CM and CBM schemes use remote monitoring and diagnosis (i.e. data is transferred from the vessel and analysed remotely), the system is to meet the applicable standards related to the assignment of the additional class notation **CYBER SECURE** from Rule Note NR659, Rules on Cyber Security for the Classification of Marine Units. The system is to be capable of continued onboard operation in the event of loss of the communication function.

2.2.6 CBM schemes are to identify defects and unexpected failures that were not prevented by the CM system.

2.2.7 Systems are to include a method of backing up data at regular intervals.

2.3 Documentation and information

2.3.1 The following documentation is to be made available to the Society for the approval of the scheme:

- a) procedure for changes to software system and CM parameters
- b) listing of equipment to be included in the scheme
- c) listing of acceptable condition monitoring parameters
- d) description of CBM scheme
- e) listing, specifications and maintenance procedures for condition monitoring equipment
- f) baseline data for equipment with condition monitoring
- g) qualification of authorized personnel and company responsible for analysing CM results.

2.3.2 In addition to the above documentation the following information is to be available on board:

- a) all the documentation in [2.3.1], duly updated
- b) maintenance instructions (manufacturer's and shipyard's)
- c) condition monitoring data including all data since last opening of the machine and the original base line data
- d) reference documentation (trend investigation procedures etc.)
- e) records of maintenance including repairs and renewals carried out
- f) records of changes to software systems and parameters
- g) sensors calibration records / certification / status.

2.4 Approval validity

2.4.1 An annual audit is to be carried out to maintain the validity of the CM/CBM scheme.

2.4.2 The survey arrangement for machinery under CM/CBM can be cancelled by the Society if the scheme is not being satisfactorily carried out either from the maintenance records or the general condition of the machinery.

2.4.3 Items under CM/CBM scheme can be cancelled from CM/CBM scheme and moved to CSM scheme by the Society if the scheme is not found to be satisfactorily maintained either from maintenance records or the general condition of the machinery, during annual and renewal audits.

2.4.4 In the case of sale or change of management of the ship or transfer of class, the approval of CM/CBM is to be reconsidered.

2.4.5 The ship owner may, at any time, cancel the CM/CBM scheme by informing the Society in writing. In this case the items which have been inspected under this scheme since the last annual audit may be credited for class at the discretion of the attending surveyor.

3 Surveys

3.1 Installation survey

3.1.1 Condition monitoring equipment is to be installed and surveyed in accordance with the Society's rules, and a set of base line readings is to be taken.

3.2 Implementation survey

3.2.1 The implementation survey is to be carried out by the Surveyor no earlier than 6 months after installation survey and no later than the first class annual survey.

3.2.2 During the implementation survey the following is to be verified by the surveyor:

- a) the CM/CBM scheme is implemented according to the approval documentation, including a comparison with baseline data
- b) the scheme is producing the documentation required for the annual audit and the requirements of surveys and testing for the maintenance of class are complied with
- c) the onboard personnel are familiar with operating the scheme
- d) records of any limiting parameters (alarms and warnings) that have been modified during the operation of the scheme
- e) records of any failures of monitored equipment are to be reviewed to ensure that the condition monitoring scheme is effective / sufficient.

3.2.3 When this survey is carried out and the implementation is found in order, a report describing the scheme is to be submitted to the Society and the scheme may be put into service.

3.3 Annual audit

3.3.1 An annual audit of the CM and CBM scheme is to be carried out by a Surveyor concurrently with the class annual survey.

3.3.2 The purpose of this audit is to be to verify that the scheme is being correctly operated and that the machinery has been functioning satisfactorily since the previous audit. This is to include any limiting parameters (alarms and warnings) that have been modified since the last audit. A general examination of the concerned items is to be carried out.

3.3.3 The performance, condition monitoring and maintenance records are to be examined to verify that the machinery has functioned satisfactorily since the previous survey, or action has been taken in response to machinery operating parameters exceeding acceptable tolerances.

3.3.4 Written details of breakdown or malfunction are to be made available.

3.3.5 At the discretion of the surveyor, function tests, confirmatory surveys and random check readings, where Condition Monitoring / Condition Based Maintenance equipment is in use, are to be carried out as far as practicable and reasonable.

3.3.6 The familiarisation of the Chief Engineer and other authorized personnel involved with the CM/CBM system is to be verified.

3.3.7 Calibration status of sensors and equipment is to be verified.

3.3.8 Verification that the suitability of the CM/CBM scheme has been reviewed following defects and failures is to be carried out.

3.3.9 An annual report covering the year's service is to be supplied to the Society. It is to include the following information:

- the list of items of machinery and components and the procedures for their identification
- the preventive maintenance sheets
- the condition monitoring data, including all data since the last dismantling and the original reference data of the machinery checked through condition monitoring
- any change to the documentation listed in [2.3]
- full trend analysis (including spectrum analysis for vibrations) of machinery displaying operating parameters exceeding acceptable tolerances.

3.4 Damage and repairs

3.4.1 Damage to components or items of machinery is to be reported to the Society. The repairs of such damaged components or items of machinery are to be carried out to the satisfaction of the Surveyor.

3.4.2 Details of repairs and maintenance carried out are to be examined. Any machinery part, which has been replaced by a spare one, due to damage, is to be retained on board where possible until examined by the Surveyor.

3.4.3 Defect and failure data is to be reviewed in order to ensure the system output is appropriate. Where necessary, following review of the failure data, there is to be a method of amending the CM and CBM scheme.

3.4.4 For bearings surveyed under the continuous survey system, when a certified monitoring system is in place such a condition based monitoring or manufacturers approved bearing wear monitoring, then there is no need to turn out the bearings unless the monitoring systems are not working properly, suggest there may have been bearings problems or the monitoring data is not available and verifiable over a period covering the CSM cycle.

SCOPE OF SURVEYS (ALL SHIPS)

SECTION 1	ANNUAL SURVEY
SECTION 2	INTERMEDIATE SURVEY
SECTION 3	CLASS RENEWAL SURVEY
SECTION 4	BOTTOM SURVEY
SECTION 5	TAILSHAFT SURVEY
SECTION 6	BOILER SURVEY
SECTION 7	HULL SURVEY FOR NEW CONSTRUCTION
SECTION 8	SURVEY OF WATERTIGHT CABLE TRANSITS
APPENDIX 1	CLASS REQUIREMENTS AND SURVEYS OF LAID-UP SHIPS

SECTION 1 ANNUAL SURVEY

1 General

1.1

1.1.1 The requirements of this Section apply to annual surveys of all ships. The specific requirements for annual surveys related to service notations and additional class notations assigned to ships are addressed in Part A, Chapter 4 and Part A, Chapter 5, respectively.

Note 1: Ships assigned with the service notation **yacht** and having a length less than 24 m are not submitted to annual surveys for hull and machinery, as described in NR500.

1.1.2 At the time of annual surveys, the ship is to be generally examined. The survey is to include a visual inspection of the hull, equipment and machinery of the ship and some tests thereof, so far as necessary and practicable in order to verify that the ship is in an acceptable general condition and is properly maintained.

1.1.3 Owners are reminded that, in compliance with the requirements in Ch 2, Sec 2, [6.4], any modification to the ship's hull, equipment and machinery affecting its classification is to be made known to the Society.

2 Hull

2.1 Hull and hull equipment

2.1.1 The survey is to include a general external examination and testing, where appropriate, of the following items, as applicable:

- outer shell plating above the waterline, relevant shell doors and accessible parts of the rudder(s)
- plating of freeboard deck and exposed decks, superstructures, with their openings and means of closure
- means of closing and securing the weathertightness of miscellaneous openings in freeboard, superstructure and exposed decks (cargo hatchways, other hatchways and other openings) (for details see [2.3])
- sidescuttles and deadlights, chutes and other openings with their means of closure
- bulwarks and, if applicable, the provision of freeing ports, special attention being paid to freeing ports with shutters
- guardrails, gangways, walkways, ladders and any other means provided for the protection of the crew and means for safe passage for crew
- inlets, scuppers and sanitary discharges, valves on discharge lines and their controls
- ventilators, air pipes, overflow pipes and gas vent pipes, with their coamings, means of closure and flame screens, where required
- flame screens on vents to all bunker tanks
- all air pipe heads installed on the exposed decks (i.e. those extending above the freeboard deck or superstructure decks)
- weld connection between air pipes and deck plating
- fittings and appliances for timber deck cargoes, where applicable
- verification of the position of the deck line (or reference line) and load lines and timber marks, if any, which, if necessary, are to be re-marked and re-painted
- deck equipment such as lifeboat davit foundations, bollards, fairleads, hawse pipes, etc., masts and associated rigging, including lightning conductors
- anchoring and mooring equipment, as far as practicable
- towing and mooring equipment properly marked with any restriction associated with its safe operation (only for ships built after 1st January 2007).
- watertight bulkheads, their watertight doors and associated local and remote controls, and their watertight penetrations
- main and auxiliary steering arrangements, including their associated equipment and control systems, and manoeuvring gear
- fire divisions and fire doors, dampers in ventilation ducts, means of closure of skylights and other openings
- confirmation, as far as practicable, that no significant changes have been made to the arrangement of the structural fire protection, including cargo spaces intended for the carriage of dangerous goods
- confirmation that emergency escape routes from accommodation and service spaces are satisfactory
- accessible cargo holds, in particular in areas likely to be damaged by cargo handling
- confirmation that the drainage from enclosed cargo spaces situated on the freeboard deck is satisfactory
- engine room
- where fitted, helicopter deck and its supporting structure, safety net and arrangements for the prevention of sliding
- availability of loading manual
- availability of electronic loading instrument, where required, and verification with standard test
- availability of approved stability documentation
- checking, in general, that there has been no deterioration in the strength of the hull

- verification that no alterations have been made to the hull or superstructures that would affect the position of the load lines
- superstructure end bulkheads and openings therein
- watertight integrity of the closures to any openings in the ship's side shell below the freeboard deck (particularly, cargo ports and other similar openings)
- garbage chutes, as far as practicable
- spurling pipes and cable lockers for verification that permanent devices are fitted to minimize water ingress
- if applicable, special requirements for ships permitted to sail with type "A" or type "B-minus" freeboard (machinery casing, gangway and access, hatchways and freeing arrangements)
- hull and its closing appliances, in general and as far as can be seen
- for ships fitted with independent cargo tanks, confirmation that cargo piping and tanks are electrically bonded to the hull, as applicable.

Note 1: Due attention is also to be given to fuel oil piping passing through ballast tanks, which is to be pressure tested where doubts arise.

2.1.2 Suspect areas identified at previous surveys are to be examined. Thickness measurements are to be taken of the areas of substantial corrosion and the extent of thickness measurements is to be increased to determine areas of substantial corrosion, in accordance with the requirements of Ch 3, Sec 3, Tab 4. These extended thickness measurements are to be carried out before the annual survey is credited as completed.

Note 1: These requirements are not applicable to cargo tanks of oil tankers, chemical tankers and double hull oil tankers surveyed in accordance with the requirements of Ch 4, Sec 3 and Ch 4, Sec 4.

2.1.3 Examination of ballast tanks when required as a consequence of the results of the class renewal survey and intermediate survey is to be carried out. When considered necessary by the Surveyor, or where extensive corrosion exists, thickness measurement is to be carried out. If the results of these thickness measurements indicate that Substantial Corrosion is found, then the extent of thickness measurements is to be increased to determine areas of substantial corrosion, in accordance with the requirements of Ch 3, Sec 3, Tab 4. These extended thickness measurements are to be carried out before the annual survey is credited as completed.

2.2 Survey of watertight cable transits

2.2.1 The Cable Transit Seal Systems Register, as detailed in Ch 3, Sec 8, is to be reviewed to confirm it is being maintained and, as far as practicable, the transits are to be examined to confirm their satisfactory condition.

2.2.2 Where there are records entered since the last annual survey of any disruption to the cable transits or installation of new cable transits, the satisfactory condition of those transits is to be confirmed by review of records and, if deemed necessary, by examination. The results are to be recorded in the Cable Transit Seal Systems Register against the specific cable transit.

2.3 Hatch covers and coamings

2.3.1 The Owner or his representative is to declare to the attending Surveyor that no significant changes have been made to the hatch covers, hatch coamings and their securing and sealing devices without prior approval of the Society.

The survey of hatch covers and coamings is to include:

- a) when fitted with portable covers, or wooden or steel pontoons, checking of the satisfactory condition, where applicable, of:
 - wooden covers and portable beams, carriers or sockets for the portable beams, and their securing devices
 - steel pontoons
 - tarpaulins
 - cleats, battens and wedges
 - hatch securing bars and their securing devices
 - loading pads/bars and the side plate edge
 - guide plates and chocks
 - compression bars, drainage channels and drain pipes (if any)
- b) when fitted with mechanically operated steel covers, checking of the satisfactory condition, as applicable, of:
 - hatch covers
 - tightness devices of longitudinal, transverse and intermediate cross junctions (gaskets, gasket lips, compression bars, drainage channels and, if any, drain pipes)
 - clamping devices, retaining bars, cleating
 - chain or rope pulleys
 - guides
 - guide rails and track wheels
 - stoppers, etc.
 - wires, chains, gypsies, tensioning devices
 - hydraulic system essential to closing and securing
 - safety locks and retaining devices
 - the operation of hatch covers, by means of random examination: stowage and securing in open condition, proper fit, locking and efficiency of sealing in closed position, operational testing of hydraulic and power components, wires, chains and link drives
- c) checking of the satisfactory condition of hatch coaming plating and its stiffeners, where applicable.

3 Machinery and systems

3.1 General machinery installations

3.1.1 The survey of general machinery installations is to cover the following items:

- confirmation that the machinery, boilers and other pressure vessels, associated piping systems and fittings are maintained so as to reduce to a minimum any danger to persons on board, due regard being given to moving parts, hot surfaces and other hazards
- confirmation that the normal operation of the propulsion machinery can be sustained or restored even though one of the essential auxiliaries becomes inoperative
- confirmation that provisions are made so as to bring the machinery into operation from the dead ship condition without external aid
- confirmation that the means of escape from accommodation, machinery and other spaces are satisfactory
- general examination of the machinery, boilers, all steam, hydraulic, pneumatic and other systems and their associated fittings, for confirmation of their proper maintenance
- examination of the means for the operation of the main and auxiliary machineries essential for the safety of the ship (including the control, monitoring, reporting, alert and safety action)
- test of the means of remotely controlling the propulsion machinery from the navigation bridge, where applicable
- examination of the arrangements to operate the main and other machineries from a machinery control room, where applicable
- confirmation that the ventilation system for the machinery spaces works correctly
- confirmation that the engine-room telegraph, the second means of communication between the navigation bridge and the machinery, and the means of communication with any other position, from where the engines can be controlled, operates satisfactorily
- confirmation that the engineer's alarm is clearly audible in the engineers' accommodation
- confirmation that the means of communication between the navigation bridge and the steering compartment are satisfactorily operating
- confirmation that the means of indicating the angular position of the rudder are satisfactorily operating
- for ships having emergency steering positions, confirmation that means of relaying heading information (telephone or other means of communication) are provided; confirmation that means to supply visual compass readings to the emergency steering position are provided if necessary
- confirmation that the various alarms required for hydraulic power-operated, electric- and electro-hydraulic steering gears work satisfactorily
- confirmation that the re-charging arrangements for hydraulically operated steering gears are maintained

- examination, as far as practicable, of the bilge pumping systems and bilge wells, including operation of the pumps, remote reach rods and level alarms, where fitted
- visual examination of the condition of any expansion joints in sea water systems
- examination of the arrangements for periodically unattended machinery spaces and, in particular, the random testing of alarms, automatic and shut-down functions
- external examination of pressure vessels other than boilers and their appurtenances, including safety devices, foundations, controls, relieving gear, high pressure piping, insulation and gauges
- examination, where applicable, of the alternative design and arrangements for machinery or electrical installations, or fire safety, in accordance with the test, inspection and maintenance requirements, if any, specified in the approved documentation.

3.1.2 When the ship is equipped with a refrigerating plant (whether or not covered by an additional class notation), the annual survey is to include the external examination of:

- pressure vessels of the installation to the same extent as indicated in [3.1.1]
- refrigerant piping, as far as practicable
- for refrigerating machinery spaces using ammonia as refrigerant:
 - ventilation system including functional test
 - water-spraying fire-extinguishing system; see [3.4.2] item d)
 - bilge system including functional test
 - electrical equipment, confirming its proper maintenance
 - gas detection system
 - breathing apparatus and protective clothing.

3.1.3 When the ship is equipped with thruster installations, the annual survey is to include:

- an external examination of the machinery installation
- an operating test of the complete installation.

3.1.4 For ships subject to compliance with the requirements laid down in Ch 6, Sec 2, [6], or in Ch 6, Sec 4, [2], or in Pt B, Ch 2, Sec 1, [2.2], the annual survey is to include an examination and a test of the water ingress detection systems and of their alarms at random.

3.1.5 For ships subject to compliance with the requirements laid down in Ch 6, Sec 2, [7], or in Pt C, Ch 1, Sec 10, [6.6.3], item e), the annual survey is to include an examination and a test of the means for draining and pumping ballast tanks forward of the collision bulkhead and bilges of dry spaces any part of which extends forward of the foremost cargo hold, and of their controls.

3.1.6 For ships fitted with an exhaust gas cleaning system (scrubber), the annual survey is to include an examination of the distance pieces on the overboard discharge system of the scrubber and a confirmation that there is no reduction of thickness of these distance pieces.

3.2 Boilers

3.2.1 For main and auxiliary steam boilers, the annual survey consists of an external examination of boilers and their appurtenances, including safety devices, foundations, controls, relieving, high pressure and steam escape piping, insulation and gauges.

The annual survey is to include test of safety and protective devices and test of safety valve using its relieving gear.

For exhaust gas heated economizers, the safety valves are to be tested by the Chief Engineer at sea within the annual survey window. This test is to be recorded in the log book for review by the attending Surveyor prior to crediting the Annual Survey of Machinery.

3.2.2 For thermal oil heaters, a functional test while in operation is to be carried out, during which the following items are checked:

- the heater for detection of leakages
- the condition of the insulation
- the operation of indication, control and safety devices
- the condition of remote controls for shut-off and discharge valves.

A satisfactory analysis of the quality of oil is to be made available to the Surveyor.

3.2.3 For exhaust gas thermal oil heaters, in addition to the requirements of [3.2.2], a visual examination and a tightness testing to the working pressure of the heater tubes are to be carried out.

3.2.4 For electrical steam generators, a functional test while in operation is to be carried out, during which the following items are checked:

- the heater system for detection of leakages
- the operation of indication, control, alarm and safety devices.

3.3 Electrical machinery and equipment

3.3.1 The survey of electrical machinery and equipment is to cover the following items:

- general examination, visually and in operation, as feasible, of the electrical installations for power and lighting, in particular main and emergency generators, electric motors, switchboards, switchgears, cables and circuit protective devices, indicators of electrical insulation and automatic starting, where provided, of emergency sources of power
- checking, as far as practicable, the operation of emergency sources of power and, where they are automatic, also including the automatic mode
- verification that the precautions provided against shock, fire and other hazards of electrical origin are maintained.

3.3.2 The survey is also to cover the bridge control of propulsion machinery, and related arrangements (alarms and safety devices), when fitted.

The survey of an automated installation covered by an additional class notation is detailed in Part A, Chapter 5.

3.3.3 The survey is also to cover the computerized systems through the control of the Software Registry as mentioned in Pt C, Ch 3, Sec 3. This survey shall include:

- checking of modification of Software Registry, in particular the reporting of security checks during software modification inside the Software Registry
- checking that revision of software mentioned in Software Registry corresponds with revision effectively used for at least one computerized system chosen at the satisfaction of the Surveyor
- checking that Software Registry has been updated according to the last ship relevant modifications.

3.3.4 For ships where the electrical distribution system includes harmonic filters, the survey is to include:

- annual measurement, as a minimum, of the harmonic distortion levels of main busbars under seagoing conditions as close to the periodical machinery survey as possible so as to give a clear representation of the condition of the entire plant to the Surveyor. Harmonic distortion readings are to be carried out when the greatest amount of distortion is indicated by the measuring equipment. An entry showing which equipment was running and/or filters in service is to be recorded in the log so this can be replicated for the next periodical survey. Harmonic distortion levels are also to be measured following any modification to the ship's electrical distribution system or associated consumers by suitably trained ship's personnel or from a qualified outside source.
- verification that records of all above measurements are made available to the Surveyor at each periodical survey.

Note 1: Those requirements apply at any scheduled machinery periodical survey having a due date on or after 1st July 2017 for ships contracted for construction before 1st July 2017.

- for ships contracted for construction on or after 1st July 2017, verification that the facilities used for continuous monitoring of the levels of harmonic distortion experienced on the main busbars as well as alerting the crew when the level of harmonic distortion exceeds the acceptable limits are working properly and review of corresponding records.

3.4 Fire protection, detection and extinction

3.4.1 The survey of fire prevention and other general arrangements is to cover the following items:

- checking that fire control plans are properly posted
- examination and testing, as feasible, of the operation of manual and/or automatic fire doors, where fitted
- checking, as far as practicable, that, where fitted, the remote controls for stopping fans in accommodation spaces and the means of cutting off power to the galley are in working order

- examination of the fire-extinguishing and special arrangements in the machinery spaces and confirmation, as far as practicable and as appropriate, of the operation of the remote means of control provided for the opening and closing of the skylights, the release of smoke, the closure of funnel and ventilation openings, the closure of power operated and other doors, the stopping of ventilation and boiler forced and induced draft fans and the stopping of oil fuel and other pumps that discharge flammable liquids
- examination of the arrangements for remote closing of valves for oil fuel, lubricating oil and other flammable oils and confirmation, as far as practicable and as appropriate, of the operation of the remote means of closing valves on the tanks that contain oil fuel, lubricating oil and other flammable oils
- test of the means of stopping power ventilation systems from outside the spaces served
- examination and testing of the closing arrangements of ventilators, funnel annular spaces, skylights, doorways, tunnel or other closing means for various openings, where applicable
- examination, as far as practicable, and testing, as feasible and at random, of the fire and/or smoke detection systems
- examination, where applicable, of the alternative design and arrangements for fire safety or life-saving appliances and arrangements, in accordance with the test, inspection and maintenance requirements, if any, specified in the approved documentation.

3.4.2 The operational readiness and maintenance of fire-fighting systems is to be checked. Confirmation that its means of operation is clearly marked. The survey requirements for all types of fire-fighting systems that are usually found on board ships related either to machinery spaces or cargo spaces or vehicle spaces or special category spaces or ro-ro spaces or accommodation spaces, irrespective of the service notation assigned, are the following:

a) water fire system

- examination of the fire main system and confirmation that each fire pump including the emergency fire pump can be operated separately so that the two required powerful jets of water can be produced simultaneously from different hydrants, at any part of the ship whilst the required pressure is maintained in the fire main
- checking that fire hoses, nozzles, applicators, spanners and international shore connection (where fitted) are in satisfactory working condition and situated at their respective locations

b) fixed gas fire-extinguishing system

- external examination of receivers of CO₂ (or other gas) fixed fire-extinguishing systems and their accessories, including the removal of insulation for insulated low pressure CO₂ containers
- examination of fixed fire-fighting system controls, piping, instructions and marking; checking for evidence of proper maintenance and servicing, including date of last system tests

- checking that fixed CO₂ fire-extinguishing systems for the protection of machinery spaces and cargo pump-rooms, where applicable, are provided with two separate controls, one for opening of the gas piping and one for discharging the gas from the storage container, each of them located in a release box clearly identified for the particular space
- test of the alarm triggered before the CO₂ is released

c) sprinkler system

- examination of the system, including piping, valves, sprinklers and header tank
- test of the automatic starting of the pump activated by a pressure drop
- check of the alarm system while the above test is carried out

d) water-spraying system

- examination of the system, including piping, nozzles, distribution valves and header tank
- test of the starting of the pump activated by a pressure drop (applicable only for machinery spaces)

e) fixed foam systems (low or high expansion)

- examination of the foam system
- test to confirm that the minimum number of jets of water at the required pressure in the fire main is obtained when the system is in operation
- checking the supplies of foam concentrate and receiving confirmation that it is periodically tested (not later than three years after manufacture and annually thereafter) by the manufacturer or an agent

f) dry powder system

- examination of the dry powder system, including the powder release control devices
- checking the supplies of powder contained in the receivers and that it has maintained its original smoothness
- checking that the pressure of propelling inert gas contained in the relevant bottles is satisfactory.

3.4.3 As far as other fire-fighting equipment is concerned, it is to be checked that:

- semi-portable and portable fire extinguishers and foam applicators are in their stowed positions, with evidence of proper maintenance and servicing, and detection of any discharged containers
- the fire fighter's outfits including its self-contained compressed air breathing apparatus and emergency escape breathing devices (EEBDs) are complete and in satisfactory condition and provision of two-way portable radiotelephone apparatus of an explosion-proof type or intrinsically safe; where more than one fire-fighter's outfit is carried, confirmation that they are stored in separated positions
- the cylinders, including the spare cylinders, of any self-contained breathing apparatus are suitably charged, and that onboard means of recharging breathing apparatus cylinders used during drills or a suitable number of spare cylinders to replace those used are provided.

3.4.4 The fire-extinguishing systems for spaces containing paint and/or flammable liquids and deep-fat cooking equipment in accommodation and service spaces are to be examined.

3.4.5 Where a helideck is fitted, the helicopter facilities are to be checked, as far as appropriate:

- drainage arrangements around the landing area
- fire fighting appliances and arrangements (to be surveyed as per [3.4.2], according to the equipment installed
- overall examination of refuelling systems and hangar facilities for cleanliness and absence of leaks, condition of gutters and drainage arrangement.

3.4.6 When appropriate, the examination of the special arrangements for carrying dangerous goods is to be carried out, including checking of the electrical equipment and wiring, the ventilation, the provision of protective clothing and portable appliances, testing any fire detection and alarm system and any sample extraction smoke detection system and testing as far as practical, the water supply, bilge pumping and any water spray system.

3.4.7 For ships designed to carry containers on or above the weather deck, as applicable, examination of the water mist lance, and as appropriate, the mobile water monitors and all necessary hoses, fittings and required fixing hardware.

3.5 General emergency alarm system

3.5.1 The general emergency alarm system is to be examined and tested.

SECTION 2 INTERMEDIATE SURVEY

1 General

1.1

1.1.1 The requirements of this Section apply to intermediate surveys of all ships. The specific requirements for intermediate surveys related to service notations and additional class notations assigned to ships are addressed in Part A, Chapter 4 and Part A, Chapter 5, respectively.

1.1.2 A survey planning meeting is to be held prior to the commencement of the survey.

1.1.3 Concurrent crediting to both Intermediate Survey and Class Renewal Survey for surveys and thickness measurements of spaces are not acceptable.

1.1.4 The intermediate survey is to include examination and checks on a sufficiently extensive part of the structure to show that the structures of the ship are in satisfactory condition so that the ship is expected to operate until the end of the current period of class, provided that the ship is

properly maintained and other surveys for maintenance of class are duly carried out during this period.

2 Hull

2.1

2.1.1 The requirements given in Tab 1 for the survey and testing of ballast tanks, cargo holds (for dry cargo ships to which the additional requirements in Ch 4, Sec 2 and Ch 4, Sec 7 do not apply) and cargo tanks (for non-ESP tankers) are to be complied with.

2.1.2 For ships fitted with independent cargo tanks, external examination of cargo tanks, as far as practicable, including tank supports, chocks and keys. The internal examination may be required if deemed necessary by the Surveyor.

For ships fitted with independent cargo tanks, confirmation that cargo piping and tanks are electrically bonded to the hull, as applicable.

Table 1 : Intermediate survey of hull (all ships)

ITEM	Age of ship (in years at time of intermediate survey)		
	5 < age ≤ 10	10 < age ≤ 15	age > 15
BALLAST TANKS	Representative ballast tanks internally examined Thickness measurements, if considered necessary by the Surveyor See (1) (2) (3)	All ballast tanks internally examined Thickness measurements, if considered necessary by the Surveyor See (1) (3)	All ballast tanks internally examined Thickness measurements, if considered necessary by the Surveyor Tightness of inner bottom plating of cargo holds in way of double bottom ballast tanks checked, if considered necessary by the Surveyor See (1) (3)
CARGO HOLDS (dry cargo ships, to which the additional requirements in Ch 4, Sec 2 and Ch 4, Sec 7 do not apply)			Selected cargo holds internally examined
CARGO SPACES (for ships other than ships engaged in the carriage of dry cargoes only, or ships subject to Ch 4, Sec 3, Ch 4, Sec 4 or Ch 4, Sec 5)		Selected cargo spaces internally examined	Selected cargo spaces internally examined
CARGO TANKS (non-ESP tankers)		Selected cargo tanks internally examined	Selected cargo tanks internally examined
<p>(1) If such examinations reveal no visible structural defects, the examination may be limited to a verification that the corrosion prevention system remains effective.</p> <p>(2) If there is no hard protective coating, soft or semi-hard coating or poor coating condition, the examination is to be extended to other ballast tanks of the same type.</p> <p>(3) For ballast tanks, excluding double bottom ballast tanks, if there is no hard protective coating, soft or semi-hard coating or poor coating condition and it is not renewed, the tanks in question are to be internally examined at annual intervals. When such conditions are found in double bottom ballast tanks, the tanks in question may be examined at annual intervals.</p> <p>Note 1: Due attention is also to be given to fuel oil piping passing through ballast tanks, which is to be pressure tested should doubts arise.</p>			

SECTION 3

CLASS RENEWAL SURVEY

1 General

1.1

1.1.1 The requirements of this Section apply to class renewal surveys of all ships. The specific requirements for class renewal surveys related to service notations and additional class notations assigned to ships are addressed in Part A, Chapter 4 and Part A, Chapter 5, respectively.

1.1.2 A survey planning meeting is to be held prior to the commencement of the survey.

1.1.3 Concurrent crediting to both Intermediate Survey and Class Renewal Survey for surveys and thickness measurements of spaces are not acceptable.

1.1.4 In addition to the requirements of the annual survey, the class renewal survey is to include sufficiently extensive examination and checks to show that the structures, main and auxiliary machinery, systems, equipment and various arrangements of the ship are in satisfactory condition or restored to such condition as to allow the ship to operate for the new period of class of five years to be assigned, provided that the ship is properly maintained and operated and other surveys for maintenance of class are duly carried out during this period.

The examinations of the hull are to be supplemented by testing and thickness measurements as required in [2.5] and [2.6], to ensure that the structural integrity remains effective. The aim of the examination is to discover substantial corrosion, significant deformation, fractures, damages or other structural deformation that may be present.

1.1.5 The Owner is to provide the necessary facilities to enable this class renewal survey. The conditions for survey as detailed in Ch 2, Sec 2, [2.5] to Ch 2, Sec 2, [2.7] are to be met.

1.1.6 When the ship is under the continuous survey system for hull or machinery, the scope of the class renewal survey as described in this Section is carried out on a continuous basis over the period of class according to the procedure laid down in Ch 2, Sec 2, [4.3].

When the machinery installation is surveyed under the Planned Maintenance System, a specific program of survey replaces the scope of the class renewal survey of machinery and systems as laid down in [3], according to the procedure laid down in Ch 2, Sec 2, [4.4].

1.1.7 Upon completion of the class renewal survey, or at the end of the period of class (if the relevant part of the ship is surveyed under the continuous survey system), a general examination of the ship having the same scope as that of an annual survey, as detailed in Ch 3, Sec 1, is to be carried out for class renewal.

2 Hull and hull equipment

2.1 Bottom survey in dry condition

2.1.1 A bottom survey in dry condition is to be carried out, as detailed in Ch 3, Sec 4, [2], and in addition the requirements given in [2.1.3] to [2.1.5] are to be complied with.

2.1.2 For ships of unusual characteristics or engaged on special services, means of underwater inspection equivalent to the bottom survey in dry condition may be considered as an alternative by the Society, particularly when a suitable high resistance paint is applied to the underwater portion of the hull or an approved system of impressed current for external cathodic protection is fitted.

2.1.3 Anchors, windlass(es) and chain cables are to be ranged and examined, and the required complement and condition are to be checked. When the ship is more than 5 years old, chain cables are to be gauged.

Any length of chain cable which is found to be damaged or excessively worn is to be renewed.

2.1.4 Sea valves and cocks are to be opened up for internal examination.

2.1.5 Thickness measurements of the outer shell plating, as and if required within the scope of the related class renewal survey, are to be carried out (refer to [2.6]), if not already done within 15 months before the end of class period.

2.2 Decks, hatch covers and equipment

2.2.1 Decks are to be examined, particular attention being given to the areas where stress concentration or increased corrosion are likely to develop, such as hatch corners and other discontinuities of structure.

Deck erections such as hatch coamings, deckhouses and superstructures are to be examined.

The sheathing of wood-sheathed steel decks may be removed, at the Surveyor's discretion, in the case of doubt as to the condition of plating underneath.

Due attention is to be given to the examination in way of end and side openings and related shell and inner doors.

2.2.2 The hatch covers and coamings are to be surveyed as follows:

- a thorough survey of the items listed in Ch 3, Sec 1, [2.3] including close-up survey of hatch cover plating and hatch coaming plating, is to be carried out. Subject to cargo hold hatch covers of approved design which structurally have no access to the internals, close-up survey is to be done of the accessible parts of hatch cover structures

- checking of the satisfactory operation of all mechanically operated hatch covers is to be made, including stowage and securing in open condition, proper fit, locking and efficiency of sealing in closed position, operational testing of hydraulic and power components, wires, chains and link drives
- checking the effectiveness of sealing arrangements of all hatch covers by hose testing or equivalent is to be carried out
- thickness measurements of coaming and attached stiffeners, hatch cover plating and stiffeners (see Tab 3).

2.2.3 The survey of hull equipment is to cover the following points:

- windlass and chain stoppers, with disassembly as deemed necessary to verify the condition of the equipment and control and safety devices, holdfasts, hawse pipes
- steering arrangements, including steering gear, control and indication devices, operational tests and disassembly as deemed necessary; in the case of chain and rod gears, chains, rods, sheaves, pins and rollers are to be examined for wear
- connection of masts and standing rigging to the hull structure as well as condition of structure underneath.

2.2.4 All bilge and ballast piping systems are to be examined and operationally tested to working pressure to attending Surveyor's satisfaction to ensure that tightness and condition remain satisfactory; see also [3.5].

2.2.5 For all ships, except ships having the service notation **passenger ship** or **ro-ro passenger ship**, automatic air pipe heads installed on the exposed decks (i.e. those extending

above the freeboard deck or superstructure decks) are to be completely examined, both externally and internally, in accordance with the requirements given in Tab 1.

2.3 Survey of watertight cable transits

2.3.1 The requirements for class renewal survey of watertight cable transits may be undertaken by the attending Surveyor or by a certified firm accepted by the Society.

Note 1: Rule Note NR533, Approval of Service Suppliers gives details about the certification.

2.3.2 All transits are to be examined to confirm their satisfactory condition and the Cable Transit Seal Systems Register is to be reviewed to confirm it is being maintained. The class renewal survey is to be recorded in the Cable Transit Seal Systems Register, in which a single record entry will be sufficient to record the survey of all transits.

2.3.3 From review of the Cable Transit Seal Systems Register, where there are records entered since the last class renewal survey of any disruption to the cable transits or installation of new cable transits (except which are reviewed and examined at previous annual surveys), the satisfactory condition of those transits is to be confirmed by the attending Surveyor by review of records and examination of the transits; the results are to be recorded in the Cable Transit Seal Systems Register against each of those cable transits.

2.3.4 In case the cable transits have been examined by an approved service supplier, the attending surveyor is to review the Cable Transit Seal Systems Register in order to ascertain that it has been properly maintained by the owner and correctly endorsed by the service supplier.

Table 1 : Requirements for internal and external examination of automatic air pipe heads at class renewal survey of all ships, except ships with service notation passenger ship or ro-ro passenger ship

Age of ship (in years at time of class renewal survey)		
Class renewal survey No.1 age ≤ 5	Class renewal survey No.2 5 < age ≤ 10	Class renewal survey No.3 and subsequent age > 10
Two air pipe heads, one port and one starboard, located on the exposed decks in the forward 0,25 L, preferably air pipes serving ballast tanks. See (1) and (2)	All air pipe heads located on the exposed decks in the forward 0,25 L. See (1) and (2)	All air pipe heads located on the exposed decks. See (3)
Two air pipe heads, one port and one starboard, on the exposed decks, serving spaces aft of 0,25 L, preferably air pipes serving ballast tanks. See (1) and (2)	At least 20% of air pipe heads on the exposed decks serving spaces aft of 0,25 L, preferably air pipes serving ballast tanks. See (1) and (2)	
<p>(1) The selection of air pipe heads to be examined is left to the attending Surveyor.</p> <p>(2) According to the results of this examination, the Surveyor may require the examination of other air pipe heads located on the exposed decks.</p> <p>(3) Exemption may be considered for air pipe heads where there is substantial evidence of replacement after the last renewal survey.</p> <p>Note 1: For designs where the inner parts cannot be properly examined from outside, the examination is to include removal of the head from the air pipe.</p> <p>Note 2: Particular attention is to be paid to the condition of the zinc coating in heads constructed from galvanised steel.</p>		

2.4 Holds and other dry compartments

2.4.1 Holds, 'tweendecks, cofferdams, pipe tunnels and duct keels, void spaces and other dry compartments which are integral to the hull structure are to be internally examined, ascertaining the condition of the structure, bilges and drain wells, sounding, venting, pumping and drainage arrangements.

At class renewal survey No.3 and subsequent class renewal surveys, structural down flooding ducts and structural ventilation ducts are to be internally examined.

2.4.2 Machinery and boiler spaces, pump rooms and other spaces containing machinery are to be internally examined, ascertaining the condition of the structure. Particular attention is to be given to tank tops, shell plating in way of tank tops, brackets connecting side shell frames and tank tops, and bulkheads in way of tank tops and bilge wells. Particular attention is to be given to the sea suction, sea water cooling pipes and overboard discharge valves and their connections to the shell plating. Where wastage is evident or suspected, thickness measurements are to be carried out, and renewals or repairs effected when wastage exceeds allowable limits.

Piping systems inside these spaces are to be dealt with according to [3.5].

2.4.3 Chain lockers are to be internally examined, while the anchor chains are ranged as required for the bottom survey in dry condition (see [2.1.3]). The pumping arrangement of the chain lockers is to be tested.

2.5 Tanks

2.5.1 The type and number of tanks to be internally examined at each class renewal survey are detailed in Tab 2, according to the age of the ship.

This internal examination is to ascertain the condition of the structure, bilges and drain wells, sounding, venting, pumping and drainage arrangements, including piping systems and their fittings. Due attention is to be given to plating or double plates below the lower end of sounding and suction pipes.

Where the inner surface of the tanks is covered with cement or other compositions, the removal of coverings may be waived provided they are examined, found sound and adhering satisfactorily to the steel structures.

Note 1: For examination of independent (non-structural) tanks, refer to [3.5.9].

Note 2: Due attention is also to be given to fuel oil piping passing through ballast tanks, which is to be pressure tested when the ship is more than 10 years old.

Note 3: For examination of independent (non-structural) storage tanks for fuel for auxiliary vehicles covered by Pt C, Ch 4, Sec 11, refer to [2.5.6].

2.5.2 Where provided, the condition of corrosion prevention system of ballast tanks is to be examined. For ballast tanks, excluding double bottom tanks, where a hard protective coating is found in poor condition and it is not renewed, where soft or semi-hard coating has been applied or where a hard protective coating was not applied from time of construction, the tanks in question are to be examined at annual intervals. Thickness measurements are to be carried out as deemed necessary by the surveyor.

Table 2 : Requirements for internal examination of integral (structural) tanks at class renewal survey

Tank	Age of ship (in years at time of class renewal survey)			
	Class renewal survey No.1 age ≤ 5	Class renewal survey No.2 5 < age ≤ 10	Class renewal survey No.3 10 < age ≤ 15	Class renewal survey No.4 and subsequent age > 15
Peaks (all use)	all	all	all	all
Ballast tanks (all types)	all	all	all	all
Fresh water	none	one	all	all
Fuel oil bunkertanks:				
• Engine room	none	none	one	one
• Cargo length area	none	one	two (1)	half, minimum 2 (1)
• If no tanks in cargo length area, additional fuel tank(s) outside of Engine room (if fitted)	none	one	one	two
Lubricating oil tanks	none	none	none	one
Cargo tanks	all	all	all	all
Storage tanks for fuel for auxiliary vehicles covered by Pt C, Ch 4, Sec 11.	none	none	one	one
(1) One deep tank is to be included, if fitted.				
Note 1: Independent non-structural tanks are to be surveyed according to [3.5.9].				
Note 2: The extent of the survey of tanks dedicated to liquids other than those indicated in this table will be considered by the Society on a case by case basis according to the nature of the liquids.				
Note 3: If a selection of tanks is accepted to be examined, then different tanks are to be examined at each class renewal survey, on a rotational basis. Tanks not internally examined may be examined externally from accessible boundaries.				

When such breakdown of hard protective coating is found in double bottom ballast tanks and it is not renewed, where a soft or semi hard coating has been applied, or where a hard protective was not applied from the time of construction, the tanks in question may be examined at annual intervals. When considered necessary by the surveyor, or where extensive corrosion exists, thickness measurements are to be carried out.

2.5.3 Boundaries of double bottom, deep, ballast, peak and other tanks, both integral and independent tanks, including holds adapted for the carriage of salt water ballast, are to be tested with a head of liquid to the top of air pipes or to near the top of hatches for ballast/cargo holds.

2.5.4 Boundaries of fuel oil, lube oil and fresh water tanks are to be tested with a head of liquid to the highest point that liquid will rise under service conditions. Tank testing of fuel oil, lube oil and fresh water tanks may be specially considered based on a satisfactory external examination of the tank boundaries, and a confirmation from the Master stating

that the pressure testing has been carried out according to the requirements with satisfactory results. The surveyor may extend the testing as deemed necessary.

2.5.5 For integral tanks which are intended to contain liquid cargoes such as edible oil, the Surveyor may waive the requirement specified in [2.5.4] subject to a satisfactory internal examination.

2.5.6 Non-structural storage tanks for fuel for auxiliary vehicles covered by Pt C, Ch 4, Sec 11, are to be externally examined; the relevant fittings, with particular regard to the remote-control shut-off valves under hydrostatic head, are to be externally examined and operationally tested to check that they are working properly and to verify the absence of cracks or leakage.

2.6 Thickness measurements

2.6.1 Thickness measurements are to be carried out according to the procedure detailed in Ch 2, Sec 2, [2.3].

Table 3 : Requirements for thickness measurements at class renewal survey

Age of ship (in years at time of class renewal survey)			
Class renewal survey No.1 age ≤ 5	Class renewal survey No.2 5 < age ≤ 10	Class renewal survey No.3 10 < age ≤ 15	Class renewal survey No.4 and subsequent age > 15
Suspect areas throughout the vessel	Suspect areas throughout the vessel	Suspect areas throughout the vessel	Suspect areas throughout the vessel
	One transverse section of deck plating in way of a cargo space within the amidships 0,5L	Two transverse sections within the amidships 0,5L in way of two different cargo spaces (2)	A minimum of three transverse sections in way of cargo spaces within the amidships 0,5L (2)
		All cargo hold hatch covers and coamings (1)	
		Internals in fore peak and after peak ballast tanks	
			All exposed main deck plating full length.
			Representative exposed superstructure deck plating (poop, bridge, and forecabin deck).
			Lowest strake and strakes in way of 'tween decks of all transverse bulkheads in cargo spaces together with internals in way.
			All wind – and water strakes, port and starboard, full length.
			All keel plates full length. Also, additional bottom plates in way of cofferdams, machinery space, and aft end of tanks.
			Plating of sea chests. Shell plating in way of overboard discharges as considered necessary by the attending surveyor
<p>(1) Including plates and stiffeners.</p> <p>(2) For ships less than 100 m in length, the number of transverse sections required when the ship's age is between 10 and 15 years may be reduced to one and the number of transverse sections required at subsequent class renewal surveys may be reduced to two. For ships more than 100 m in length, when the ship's age is between 10 and 15 years, thickness measurements of exposed deck plating within amidship 0,5 L may be required.</p> <p>Note 1: Subject to cargo hold hatch covers of approved design which structurally have no access to the internals, thickness measurement is to be done of the accessible parts of hatch cover structures.</p>			

Table 4 : Guidance for additional thickness measurements in way of substantial corrosion areas

Structural member	Extent of measurements	Pattern of measurements
Plating	Suspect area and adjacent plates	5 point pattern over 1 square metre
Stiffeners	Suspect area	3 measurements each in line across web and flange

The extent of thickness measurements is detailed in Tab 3, according to the age of the ship. The Surveyor may extend the thickness measurements as deemed necessary. When thickness measurements indicate substantial corrosion, the extent of thickness measurements is to be increased to determine areas of substantial corrosion in accordance with the requirements of Tab 4. These extended thickness measurements are to be carried out before the survey is credited as completed.

Thickness measurements locations are to be selected to provide the best representative sampling of areas likely to be most exposed to corrosion, considering cargo and ballast history and arrangement and condition of protective coatings.

Thickness measurements of internals may be specially considered by the Surveyor if the hard protective coating is in good condition.

2.7 Independent cargo tanks

2.7.1 All independent cargo tanks are to be cleaned and examined internally, as well as their liquid-level indicators.

2.7.2 When accessible, the outer surface of uninsulated cargo tanks or the outer surface of cargo tank insulation is to be examined.

Special attention is to be given to the tank and insulation in way of chocks, supports, keys, anti-rolling/pitching systems.

Removal of insulation, in part or entirely, may be required in order to verify the condition of the tank or the insulation itself if deemed necessary by the Surveyor.

2.7.3 Thickness measurements may be required if deemed necessary by the Surveyor.

2.7.4 The tightness of all cargo tanks is to be verified by an appropriate procedure.

2.7.5 The pressure relief valves for the cargo tanks are to be opened for examination, adjusted, function tested and sealed. Where a proper record of continuous overhaul and re-testing of individually identifiable relief valves is maintained, consideration may be given to acceptance on the basis of opening, internal examination and testing of a representative sample of valves, including each size and type of relief valves in use, provided there is evidence in the log-book that the remaining valves have been overhauled and tested since crediting of the previous class renewal survey.

2.7.6 The cargo containment venting system is to be examined.

2.7.7 All piping, equipment and machinery for loading, venting, heating or otherwise handling the cargo are to be examined. Insulation is to be removed as deemed necessary to ascertain the condition of the pipes.

If the visual examination raises doubts as to the integrity of the pipelines, a pressure test at 1,25 times the MARVS for the pipeline is to be carried out. After reassembly the complete piping systems are to be tested for leaks.

2.7.8 All emergency shutdown and quick-closing valves in the cargo piping systems are to be examined and proven operable. A random selection of valves is to be opened up for examination.

2.7.9 Holds around cargo tanks are to be internally examined. In case of ships built without longitudinal bulkhead in the centre line of the ship, and fitted with long deck beams, the welded connections between the deck beams and the plating of the double hull spaces are to be thoroughly examined.

3 Machinery and systems

3.1 General

3.1.1 The survey items listed below are to be covered to the satisfaction of the Surveyor. However, other survey alternatives deemed equivalent by the Surveyor in relation to the characteristics and general condition of the ship concerned may also be accepted.

As part of the Class Renewal Survey of Machinery, a dock trial is to be carried out, to the satisfaction of the attending Surveyor, to confirm satisfactory operation of main and auxiliary machinery. If significant repairs are carried out to main or auxiliary machinery or steering gear, consideration is to be given to a sea trial, to the satisfaction of the attending Surveyor.

If the significant repairs as stated above, is considered by the Society to have any impact on response characteristics of the propulsion systems, then the scope of sea trial shall also include a test plan for astern response characteristics based on those required for such an equipment or system when fitted to the new ship. Refer to Pt C, Ch 1, Sec 15, [3.3.2] for astern testing requirements.

The tests are to demonstrate the satisfactory operation of the equipment or system under realistic service conditions at least over the manoeuvring range of the propulsion plant, for both ahead and astern directions.

Depending on the actual extent of the repair, the Society may accept a reduction of the test plan.

Note 1: Attention is drawn to the requirement Ch 2, Sec 2, [2.5.1] regarding safe execution of surveys, in particular as regards health hazards related to asbestos.

3.2 Main and auxiliary engines and turbines

3.2.1 General

Depending on the type of machinery, the following parts are to be opened up as necessary for inspection, unless surveyed in accordance with Ch 2, Sec 2, [4.3.6], items e) and f). Parts and components are to be pressure tested as appropriate or as deemed necessary by the Surveyor. A working test is also to be carried out, including testing of alarms and safety devices.

3.2.2 Internal combustion engines

- a) Columns and entablature
- b) Cylinders with their liners, cylinder covers (together with valves and valve gear), pistons with their rods, crossheads, slippers and guides (or gudgeon pins), connecting rods (with their top and bottom end bearings), control gear, driven scavenge pumps, driven air compressors, driven fuel pumps, supercharging blowers, fuel injection pumps, turning gear, etc.
- c) Crankshafts (together with their main bearings)
- d) Reverse gear, reduction gear and clutches, if fitted.

3.2.3 Steam turbines

- a) Condensers and their cooling water and condensate extraction pumps
- b) Casings and rotors (including their blading), impulse wheels (including guide blading and diaphragms), nozzles and nozzle boxes, journals and bearings, dummy pistons, labyrinths, external glands, etc.
- c) Shafts, including their flexible couplings.

Where the propulsion steam turbines are of a well-known type, and fitted with rotor position indicators and vibration indicators of an approved type, as well as measuring equipment of steam pressure at proper locations along the steam flow, and the arrangements for change-over in the event of emergency operation of the plant are readily operable, the first class renewal survey may be limited to the examination of rotor bearings, thrust bearings and flexible couplings, provided the Surveyor is satisfied from operation service records and power trials subsequent to the survey, that the turbine plant is in good working condition.

3.2.4 Gas turbines

- a) Casings, rotors and disks, impellers and blading of all turbines and compressors, combustion chambers, burners, heat exchangers, gas piping, compressed air piping with fittings, starting and reverse arrangements
- b) Shafts and their flexible couplings.

3.2.5 Electric propulsion

Where the propulsion machinery consists of an electrical system, the propulsion motors, generators, cables and all ancillary electrical gear, exciters and ventilating plant (including coolers) associated therewith are to be examined and the insulation resistance to earth tested. Due attention is to be given to windings, commutations and sliprings. The operation of protective gear and alarm devices is to be

checked, as far as practicable. Interlocks intended to prevent unsafe operations or unauthorised access are to be checked to verify that they are functioning correctly.

3.2.6 Thruster installations

When the ship is equipped with thruster installations, the class renewal survey is also to include:

- an examination of the machinery and electrical installation, as applicable
- an external examination of the propulsive part of the installation to be carried out at the dry dock survey due as part of the class renewal survey. During this examination other checks such as clearance readings, tightness of hub and blade sealing for controllable pitch propellers are to be verified. Locking arrangements for bolts, if fitted, are to be checked. Results of lubricating oil analysis to detect possible deterioration of internal gears and bearings or the presence of water are to be confirmed as acceptable. The Manufacturer's requirements may be taken into account. Dismantling of the assembly for the examination of internal parts may be required if the foregoing checks are not satisfactory
- a running test of the system under operating conditions.

3.2.7 Pod propulsion systems

When the ship is equipped with pod propulsion systems, the class renewal survey is to include the examination of:

- electric propulsion motors and associated equipment, see [3.2.5]
- pod orientation device (gears and wheels, hydraulic/electric system, sealing arrangements)
- oil lubricating system of shaft bearings
- bilge system inside pod
- ventilation and cooling system
- rotating commutator
- alarm system.

3.3 Reduction gears, main thrust and intermediate shaft(s)

3.3.1 Reduction gears complete with all wheels, pinions, shafts, couplings, bearings and gear teeth, including incorporated clutch arrangements, are to be opened up, as deemed necessary by the Surveyor, for visual inspection. For complicated assemblies, gears and roller bearings may be surveyed without dismantling.

3.3.2 All shafts, thrust blocks and bearings are to be examined.

3.4 Pumps and other machinery items

3.4.1 General

The items listed in [3.4.2] are to be opened up, as deemed necessary by the Surveyor, for visual inspection. Their parts and components are to be pressure tested as appropriate and considered necessary by the Surveyor. A working test is also to be carried out, including testing of alarms and safety devices if deemed necessary by the Surveyor.

3.4.2 Items to be surveyed

- a) Air compressors with their intercoolers, filters and/or oil separators and safety devices
- b) Heat exchangers, ventilation fans for boilers and other equipment used for essential services
- c) Piston pumps and centrifugal pumps for sea water, bilge and salt water ballast
- d) Screw pumps, gear pumps and centrifugal pumps other than those listed in c) above (opening up is not required).

3.5 Systems in machinery spaces

3.5.1 Valves, cocks and strainers of the bilge and ballast systems are to be opened up, as deemed necessary by the Surveyor, for visual inspection, and, together with the piping and safety devices, examined and tested under working conditions.

3.5.2 The fuel oil, lubricating oil, hydraulic oil, thermal oil, and feed and cooling water systems, together with pressure filters, heaters and coolers used for essential services, are to be opened up and examined or tested, as considered necessary by the Surveyor. Safety devices for the foregoing items are to be examined.

3.5.3 The compressed air system together with its valves, fittings and safety devices is to be examined, as considered necessary by the Surveyor.

3.5.4 Compressed air receivers and other pressure vessels for essential services are to be cleaned internally and examined internally and externally. Their fittings, valves and safety devices are to be opened up, as deemed necessary by the Surveyor, for visual inspection and pressure tested as appropriate.

3.5.5 Steel pipes for superheated steam having a temperature of the steam at the superheater outlet exceeding 450°C are to be examined and tested in accordance with [3.5.7] to [3.5.8] at each class renewal survey.

3.5.6 Steel pipes for saturated steam or superheated steam having a temperature of the steam at the superheater outlet not exceeding 450°C are to be examined and tested in accordance with [3.5.7] to [3.5.8] at each class renewal survey for ships over 5 years of age. When the ship is 5 years of age or less, the inspection may be limited to a check of the satisfactory general condition of pipes.

3.5.7 The examination and hydrostatic test of steel pipes for main steam machinery, and steel pipes for auxiliary steam machinery having internal diameter 75 mm and over, are to be carried out on a number of pipes selected by the Surveyor after the lagging in way is removed.

3.5.8 Representative pipe lengths connected with bolted flanges are to be internally and externally examined, and hydrostatically tested to 1,1 times the working pressure at ambient temperature. Bolts and butt-welded joints between flanges and pipes are to be submitted to a non-destructive test for crack detection.

3.5.9 Non-structural tanks located in machinery spaces are to be externally examined; the relevant fittings, with particular regard to the remote control shut-off valves under hydrostatic head, are to be externally examined and operationally tested to check that they are working properly and to verify the absence of cracks or leakage.

3.5.10 When the ship is equipped with a refrigerating plant (whether or not covered by an additional class notation), the class renewal survey is to include:

- examination and test at the design pressure of the parts of the plant under pressure
- for refrigerating machinery spaces using ammonia as refrigerant:
 - examination and test of the water-spraying fire-extinguishing system to the same extent as indicated in [3.8.3], item d)
 - examination of valves and pumps of the bilge system to the same extent as indicated in [3.4]
 - examination and test of the electrical equipment to the same extent as indicated in [3.6.11]
 - test of the gas detection system.

3.6 Electrical equipment and installations

3.6.1 An electrical insulation resistance test is to be performed on the electrical equipment and cables. If needed, for the purpose of this test, the installation may be subdivided or equipment which may be damaged disconnected.

3.6.2 The following minimum values, when performing the insulation test, are to be considered:

- for main and emergency switchboards, feeder circuit breakers being open, busbar circuit closed, measuring and monitoring instruments disconnected, the resistance of insulation measured across each insulated busbar and the hull, and across insulated busbars, should not be less than 1 megohm
- for generators, the equipment and circuits normally connected between the generator and the first circuit breaker being connected, the resistance of insulation (preferably at working temperature whenever possible), in ohms, is to be greater than 1 000 times the rated voltage, in volts. If appropriate, the Surveyor checks also that the insulation resistance of generators separate exciter gear is not less than 1 megohm
- the insulation resistance of the entire electrical system is to be checked with all circuit breakers and protective devices closed, except for generators; in general, the resistance should not be less than 100 000 ohms. However, the variation of the resistance with time is to be checked, comparing the current figure with previous readings. If the insulation resistance was to drop suddenly or be insufficient, the defective circuits are to be traced, disconnecting the circuits as much as necessary.

3.6.3 The prime movers of generators are to be surveyed in accordance with [3.2] and their governors tested. All generators are to be presented for inspection, clean and with covers opened and examined under working conditions.

3.6.4 Main and emergency switchboards, section boards and distribution boards are to be cleaned and doors or covers opened for examination of their fittings. The condition of overcurrent protective devices and fuses is to be checked. Circuit-breakers of generators are to be tested, as far as practicable, to verify that protective devices including preference tripping relays, if fitted, operate satisfactorily. It is to be verified that there are no loose connections on busbar.

3.6.5 Electrical cables and cable runs are to be examined at random, in particular in places where deterioration is likely to occur; terminal boxes of essential services are also to be subjected to a random check.

3.6.6 The motors and starters concerning essential services together with associated control and switchgear are to be examined and, if considered necessary by the Surveyor, checked, as far as practicable, under working conditions.

3.6.7 Navigation light indicators are to be tested under working conditions, and correct operation on the failure of supply or failure of navigation lights verified.

3.6.8 The emergency sources of electrical power, their automatic arrangements and associated circuits are to be tested.

3.6.9 Emergency lighting, transitional emergency lighting, supplementary emergency lighting, general emergency alarm and public address systems are to be tested as far as practicable.

3.6.10 The visible condition of electrical equipment and installations is also to be checked as regards precautions against shock, fire and other hazards of electrical origin.

3.6.11 A general examination of the electrical equipment in areas where there may be flammable gas or vapour and/or combustible dust is to be carried out to ensure that the integrity of the electrical equipment of a safety type has not been impaired owing to corrosion, missing bolts, etc., and that there is not an excessive build-up of dust on or in dust-protected electrical equipment. Cable runs are to be examined for sheath and armouring defects, where practicable, and to ensure that the means of supporting the cables are in satisfactory condition. The proper condition of bonding straps for the control of static electricity is to be checked. Alarms and interlocks associated with pressurised equipment or spaces are to be tested for correct operation.

Note 1: Owners are reminded that maintenance, repairs or renewal of certified electrical equipment of a safe type remains their responsibility or that of their representatives.

3.6.12 The survey is also to cover the computerized systems through the control of the Software Registry as mentioned in Pt C, Ch 3, Sec 3. This survey shall include:

- checking of modification of Software Registry, in particular the reporting of security checks during software modification inside the Software Registry
- checking that revision of software mentioned in Software Registry corresponds with revision effectively used for each computerized system
- checking that Software Registry has been updated according to the last ship relevant modifications.

3.6.13 For ships where the electrical distribution system includes harmonic filters, the survey is to include:

- annual measurement, as a minimum, of the harmonic distortion levels of main busbars under seagoing conditions as close to the periodical machinery survey as possible so as to give a clear representation of the condition of the entire plant to the surveyor. Harmonic distortion readings are to be carried out when the greatest amount of distortion is indicated by the measuring equipment. An entry showing which equipment was running and/or filters in service is to be recorded in the log so this can be replicated for the next periodical survey. Harmonic distortion levels are also to be measured following any modification to the ship's electrical distribution system or associated consumers by suitably trained ship's personnel or from a qualified outside source.
- verification that records of all above measurements are made available to the surveyor at each periodical survey.

Note 1: Those requirements apply at any scheduled machinery periodical survey having a due date on or after 1st July 2017 for ships contracted for construction before 1st July 2017.

- for ships contracted for construction on or after 1st July 2017, verification that the facilities used for continuous monitoring of the levels of harmonic distortion experienced on the main busbars as well as alerting the crew when the level of harmonic distortion exceeds the acceptable limits are working properly and review of corresponding records.

3.7 Controls

3.7.1 Where remote and/or automatic controls, not covered by an additional class notation related to automated installation, are fitted for essential machinery, they are to be tested to demonstrate that they are in satisfactory condition.

3.8 Fire protection, detection and extinction

3.8.1 The Owner or his representative is to declare to the attending Surveyor that no significant changes have been made to the arrangement of structural fire protection.

Note 1: Attention is drawn to the provisions of Ch 1, Sec 1, [3.1.1] regarding compliance with any additional and/or more stringent requirements issued by the Administration of the State whose flag the ship is entitled to fly.

3.8.2 The class renewal survey of fire prevention arrangements is to cover the following items.

- a) Visible parts of items forming part of structural fire protection arrangements in accommodation spaces and in machinery spaces such as bulkheads, decks, doors, stairways, crew and service lift trunks, and light and air trunks are to be examined, due attention being given to their integrity and that of the insulating material.
- b) The operation of manual/automatic fire doors, where fitted, is to be checked.

- c) Remote controls for stopping fans and machinery and shutting off fuel supplies in machinery spaces and, where fitted, remote controls for stopping fans in accommodation spaces and means of automatically shutting off the electrical power of the deep-fat cooking equipment upon activation of the fire-extinguishing system are to be tested.
- d) Closing arrangements of ventilators, funnel annular spaces, skylights, doorways and tunnels, where applicable, are to be tested.
- e) Fire and/or smoke detection and alarm systems are to be tested.

3.8.3 The survey requirements for all types of fire-fighting systems that are usually found on board ships related either to machinery spaces or to cargo areas and/or spaces or to accommodation spaces, irrespective of the service notation assigned, are the following:

- a) water fire system
 - the associated pumps are to be opened up and examined at the Surveyor's discretion
 - the fire main is to be hydrostatically tested to the working pressure at the Surveyor's discretion

- b) fixed gas fire-extinguishing system

Receivers of CO₂ (or other gas) fixed fire-extinguishing systems are to be externally examined together with all stationary fittings and devices. In addition, the following applies:

- the total loss of CO₂ is not to exceed 10% of the installed quantity (5% for Halon)
- after being repaired or discharged, containers are to be subjected to a hydrostatic test
- hydrostatic testing of high pressure CO₂ containers is to be carried out at intervals not exceeding 10 years; the number of the tested containers is to be not less than 10% of the total number
- low pressure CO₂ containers are to be internally surveyed if the content has been released and the container is older than five years; depending upon the result of the internal examination, the Surveyor may require the container to be hydrostatically tested.

It is to be checked that the distribution pipework is proved clear.

- c) sprinkler system
 - the associated pumps are to be opened up and examined at the Surveyor's discretion

- d) water spraying system
 - the associated pumps are to be opened up and examined at the Surveyor's discretion
 - a working test is to be carried out as far as reasonable and appropriate
- e) fixed foam systems (low or high expansion)
 - the associated pumps are to be opened up and examined at the Surveyor's discretion
- f) dry powder system
 - it is to be verified that the propelling inert gas bottles have been hydrostatically tested. The same applies to bottles disembarked for refilling or embarked for replacement.

3.8.4 As far as other fire-fighting equipment is concerned, the following items are to be hydrostatically tested, at intervals not exceeding 10 years:

- any CO₂ bottles of extinguishers
- shells of foam extinguishers
- shells of powder extinguishers
- air or gas bottles associated with fire extinguishers whose shells are not kept under pressure (if internally examined, the test need not be performed).

3.8.5 Where a helideck is fitted, the following is to be checked, as far as appropriate:

- drainage arrangements around the landing area
- fire fighting appliances and arrangements (to be surveyed as per [3.8.3] and [3.8.4], according to the equipment installed)
- other arrangements for helicopter refuelling and hangar facilities (fuel system, ventilation, fire protection and detection).

3.9 Hold, ballast and dry spaces water level detectors

3.9.1 For ships subject to compliance with the requirements laid down in Ch 6, Sec 2, [6], or in Ch 6, Sec 4, [2], or in Pt B, Ch 2, Sec 1, [2.2], the class renewal survey is to include an examination and a test of the water ingress detection systems and of their alarms.

3.10 Availability of pumping systems

3.10.1 For ships subject to compliance with the requirements laid down in Ch 6, Sec 2, [7], or in Pt C, Ch 1, Sec 10, [6.6.3], item e), the class renewal survey is to include an examination and a test of the means for draining and pumping ballast tanks forward of the collision bulkhead and bilges of dry spaces any part of which extends forward of the foremost cargo hold, and of their controls.

SECTION 4

BOTTOM SURVEY

1 General

1.1

1.1.1 Examinations of the outside of ship's bottom and related items of ships is normally to be carried out with the ship in dry-dock or on a slipway. However, consideration may be given to alternate examination while the ship is afloat as an in-water survey, subject to provisions of Ch 2, Sec 2, [5.4] and [3] of this Section.

Note 1: for ships assigned with the service notation **yacht** or **charter yacht**, reference is made to the Rule Note NR500, Rules for the Classification and Certification of Yachts.

2 Bottom survey in dry condition

2.1 General requirements

2.1.1 When a ship is in dry-dock or on a slipway, it is to be placed on blocks of sufficient height and with the necessary staging to permit the examination of elements such as shell plating including bottom and bow plating, stern frame and rudder, sea chests and valves, propeller.

2.1.2 The shell plating is to be examined for excessive corrosion, or deterioration due to chafing or contact with the ground or for any undue unfairness or buckling. Special attention is to be paid to the connection between the bilge strakes and the bilge keels and to the plating of end structures (stem and sternframes). Important plate unfairness or other deterioration which do not necessitate immediate repairs are to be recorded.

2.1.3 Sea chests and their gratings, sea connections and overboard discharge valves and cocks and their fastenings to the hull or sea chests are to be examined. Sea valves and cocks need not be opened up more than once in a period of class unless considered necessary by the Surveyor.

For ships fitted with box coolers (chest coolers), the connection between the box cooler and the sea chest top plate are to be specifically examined from both sea side and inside (dry side) at bottom survey in drydock only.

2.1.4 Visible parts of the propeller(s), stern bush(es), propeller shaft boss, brackets and tightness system(s) are to be examined. The clearances of the propeller shaft(s) (or wear down gauge) are to be checked and recorded. For controllable pitch propellers, the Surveyor is to be satisfied with the fastenings and tightness of hub and blade sealing.

Visible parts of side thrusters are to be examined. Other propulsion systems which also have manoeuvring characteristics (such as directional propellers, vertical axis propellers, water jet units) are to be examined externally with focus on the condition of gear housing, propeller blades, bolt locking and other fastening arrangements. Sealing arrangement of propeller blades, propeller shaft and steering column shall be verified.

Note 1: For the survey of propeller shafts, refer to Ch 3, Sec 5.

Dismantling is to be carried out, if considered necessary, notably where leakages are detected.

2.1.5 Visible parts of the rudder(s), rudder pintles, rudder stock and couplings as well as the sternframe are to be examined. If considered necessary by the Surveyor, the rudder(s) is (are) to be lifted or the inspection plates removed for the examination of pintles.

The clearances in the rudder bearings and the rudder lowering are to be checked and recorded.

Where applicable, pressure test of the rudder may be required as deemed necessary by the Surveyor.

2.2 Bottom survey held within the scope of class renewal survey

2.2.1 The examination and checks detailed in Ch 3, Sec 3, [2.1] are to be carried out as part of the class renewal survey. They are usually carried out during the bottom survey held concurrently with the class renewal survey.

3 Bottom in-water survey

3.1 General

3.1.1 An in-water survey may normally be carried out if the ship has been granted the additional class notation **INWATER-SURVEY** as defined in Ch 1, Sec 2, [6.14.3]. Upon application by the Owner, the Society may also authorise, on a case-by-case basis, such bottom in-water survey for ships not assigned with the additional class notation **INWATERSURVEY**.

3.1.2 In principle, no outstanding conditions of class are to exist requiring repair work to be carried out to the underwater part of the shell plating, the rudder, the propeller or the propeller shaft, unless the Society is satisfied that such repairs may be carried out while the ship is afloat.

3.1.3 Proposals for in-water survey are to be submitted in advance of the survey by the Owner so that satisfactory arrangements can be agreed with the Society.

The in-water survey is to be carried out with the ship in sheltered water and preferably with weak tidal streams and currents. The in-water visibility and the cleanliness of the hull below the waterline are to be clear enough to permit a meaningful examination allowing the Surveyor and the in-water survey firm to determine the condition of the plating, the appendages and the welding.

The equipment, procedure for observing and reporting the survey are to be discussed with the parties involved prior to the in-water survey, and suitable time is to be allowed to permit the in-water survey firm to test all equipment beforehand.

3.1.4 The in-water survey is to be carried out under the surveillance of a Surveyor by an in-water survey firm approved as a service supplier by the Society according to Ch 2, Sec 2, [2.4].

The Surveyor is to be satisfied with the methods of orientation of the diver(s) or remotely operated vehicle (ROV) on the plating, which should make use where necessary of per-

manent markings on the plating at selected points and with the method of pictorial representation. An efficient two-way communication between the Surveyor and the diver(s) is to be provided.

3.1.5 The in-water survey is to provide the information normally obtained from a bottom survey in dry condition. Special consideration shall be given to ascertaining rudder bearing clearances and stern bush clearances of oil stern bearings based on a review of the operating history, on board testing and stern oil sample reports. These considerations are to be included in the proposals for in-water survey as required in [3.1.3].

Upon completion of the survey, the approved diving firm is to submit to the attending Society Surveyor a detailed report including video tapes, as well as a photographic documentation of the main parts inspected.

3.1.6 If the in-water survey reveals damage or deterioration that requires immediate attention, the Surveyor may require that the ship be drydocked in order that a detailed survey can be undertaken and the necessary repairs carried out.

SECTION 5

TAILSHAFT SURVEY

1 Survey of tailshafts

1.1 General

1.1.1 The different types of surveys to which tailshafts may be subjected and the intervals at which they are to be carried out are given in Ch 2, Sec 2, [5.5]. These surveys are:

- complete survey
- modified survey.

The requirements to be complied with at each survey are listed in [1.2] and [1.3].

1.2 Complete survey

1.2.1 The complete survey of tailshafts consists of the following, as applicable:

- a) removal of propeller and key, where fitted, and their examination

Note 1: Where the propeller is fitted keyless to the shaft taper and where the additional class notation **MON-SHAFT** has been assigned, refer to item c), Note 3.

- b) complete withdrawal of shaft to permit the examination of sterntube bearings (outboard or inboard depending on the type of shaft)
- c) examination by an appropriate crack detection method of the after end of the cylindrical part of the shaft and forward one third of shaft cone, or the fillet of the flange in the case of a flanged coupling

Note 2: Refer also to Ch 2, Sec 2, [5.5.2], item b) where the crack detection test of the aft flange fillet area may be dispensed with for the solid flange couplings fitted at the end of the shaft.

Note 3: Refer also to Ch 2, Sec 2, [5.5.2], item b) where the propeller is fitted keyless to the shaft taper, and, where the additional class notation **MON-SHAFT** has been assigned, the non-destructive examination is carried out at intervals not exceeding 15 years.

- d) examination of shaft bearing surfaces, liners, joints, threaded end and nut
- e) examination of oil sealing glands with the necessary dismantling
- f) measurements of clearances and/or wear (prior to and after the survey) and their recording
- g) opening-up of controllable pitch propellers and examination of their working parts and control gear, if considered necessary.

1.2.2 Where the notation **MON-SHAFT** has been assigned as specified in Ch 1, Sec 2, [6.6.3], the tailshaft need not be withdrawn at the complete survey and items b) and d) of [1.2.1] need not be covered provided that all condition monitoring data (aft bearing temperature, consumption and analysis of lubricating oil) is found to be within permissible limits and the remaining requirements for the complete survey are complied with.

Where the Surveyor considers that the data presented is not entirely to his satisfaction, the shaft is to be withdrawn.

1.3 Modified survey

1.3.1 A modified survey may be carried out for those tailshafts which fulfil the conditions described in Ch 2, Sec 2, [5.5.3], where the periodicity of this type of survey is also shown.

The modified survey of water lubricated systems is eligible under the condition that the additional class notation **MON-SHAFT** has been assigned as specified in Ch 1, Sec 2, [6.6.3].

1.3.2 General

For the different types of shafts, the following is required:

- a) for shafts with keyed propeller coupling:
 - removal of propeller and key, and their examination in way of the connection area
 - examination by an appropriate crack detection method of the after end of the cylindrical part of shaft and forward one third of shaft cone
- b) for shafts with keyless type propeller coupling:
 - check of the tightness of the propeller hub (propeller hood, fore gland)
- c) for shafts with a solid flange coupling at the aft end and variable pitch propeller:
 - check of tightness in way of blade glands and distribution box
 - check of analysis of hydraulic oil
 - working test, as far as practicable, of the blade manoeuvring.

1.3.3 See also Ch 2, Sec 2, [5.5.3] and Ch 5, Sec 6, [3], as relevant.

1.3.4 Where the Surveyor considers that the data presented is not entirely to his satisfaction, further dismantling may be required, including withdrawal of the tailshaft.

2 Periodical survey of other propulsion systems

2.1 Rotating and azimuth thrusters

2.1.1 The periodical survey of rotating and azimuth thrusters consists of:

- a) removing the propeller(s) in order to examine the following items, as applicable:
 - exposed parts
 - cone and keyway to be checked by an appropriate crack detection method
 - sealing glands
 - threaded end and nut
- b) examining the results of a lubricating oil analysis (water content and presence of material particles) to detect possible deterioration of internal gears and bearings
- c) examining the orientation device.

If the foregoing checks are not satisfactory, dismantling of the internal parts may be required.

2.2 Vertical axis propellers

2.2.1 The periodical survey of vertical axis propeller systems consists of:

- checking the tightness of the oil glands and the backlash of the gears from outside by action on the blades
- checking the condition of gears and couplings from inside the ship
- examining the results of a lubricating oil analysis (water content and presence of material particles) to detect possible deterioration of internal gears and bearings.

If the foregoing checks are not satisfactory, dismantling of the internal parts may be required.

2.3 Pump jet systems

2.3.1 The periodical survey of pump jet systems consists of examining the following parts:

- impeller, shaft and clearances of bearings
- tightness of gland
- water duct
- steering nozzle
- reversing arrangements and control gear.

If the foregoing checks are not satisfactory, further dismantling may be required.

2.4 Pod propulsion systems

2.4.1 The scope of complete and - where applicable- modified survey of the pod propulsion system shafting arrangement is the one detailed in [1.2] and [1.3] for tailshafts.

2.4.2 Where the system is fitted with:

- a vibration monitoring of roll bearings
- a temperature monitoring of bearings, and
- a monitoring of automatic bilge pumping system,

the shaft need not be withdrawn at the complete survey and items b) and d) of [1.2.1] need not be covered provided that all condition monitoring data (vibrations and temperatures in way of bearings, consumption and analysis of lubricating oil, running rate of bilge system) are found to be within permissible limits and the remaining requirements for the complete survey are complied with.

Where the Surveyor considers that the data presented is not to his satisfaction, further dismantling are to be required.

3 Survey of propeller shafts and tube shafts

3.1 General

3.1.1 Application

Unless alternative means are provided to assure the condition of the propeller shaft assembly, these requirements apply to all ships with conventional shafting fitted with a propeller, as follows:

- from 1 January 2016, for ships delivered on or after 1 January 2016
- after the first shaft survey scheduled on or after 1 January 2016, for ships delivered before 1 January 2016.

Note 1: Upon the completion of the first shaft survey scheduled on or after 1 January 2016, the designation of dates for the next shaft survey is to be made based upon the requirements of this Article.

3.1.2 Definitions

See also Fig 1.

a) Shaft

For the purpose of this Article, shaft is a general definition that includes:

- propeller shaft
- tube shaft.

The definition does not include the intermediate shafts which are considered as part of the propulsion shafting inside the ship.

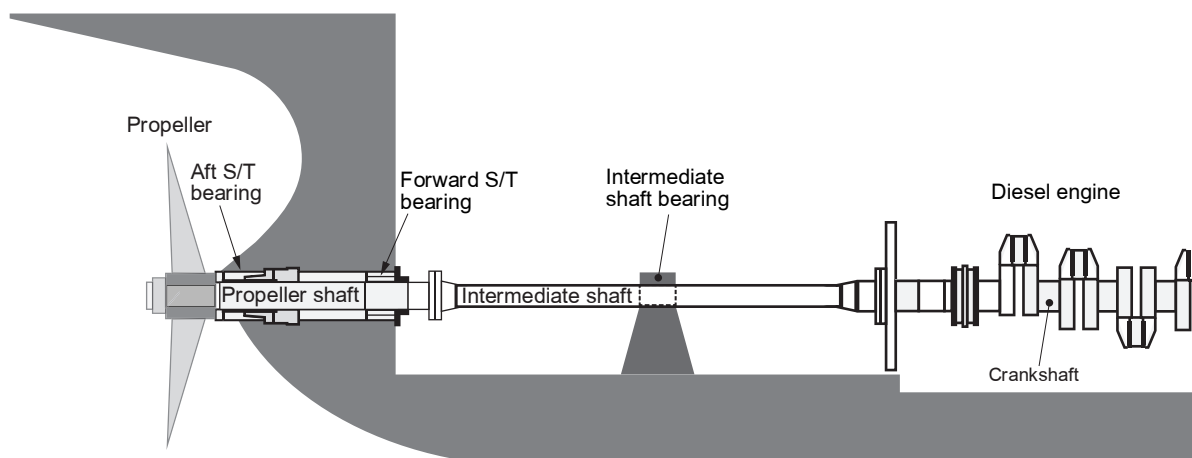
b) Propeller shaft

Propeller shaft is the part of the propulsion shaft to which the propeller is fitted. It may also be called screwshaft or tailshaft.

c) Tube shaft

Tube shaft is a shaft placed between the intermediate shaft and the propeller shaft, normally arranged within a stern tube or running in open water. It may also be called sterntube shaft.

Figure 1 : Typical shafting arrangement



d) Sterntube

Tube or pipe fitted in the shell of a ship at the stern (or rear part of the ship), below the waterline, through which passes the tube shaft or the aftermost section of the propeller shaft.

Sterntube is the housing of the shaft bearings, generally two (one aft and one fore), that sustain the shaft and allow its rotation with less frictional resistance. The sterntube also accommodates the shaft sealing arrangement.

e) Closed loop (system) oil lubricated bearing

Closed loop oil lubricating systems use oil to lubricate the bearings and are sealed against the environment (seawater) by adequate sealing/gland devices.

f) Water lubricated bearing

Water lubricated bearings are bearings cooled/lubricated by water (fresh or salt).

g) Closed loop (system) fresh water lubricated bearing

Closed loop water lubricating systems use fresh water to lubricate the bearings and are sealed against the environment (such as seawater) by adequate sealing/gland devices.

h) Open systems (water)

Open water lubricating systems use water to lubricate the bearings and are exposed to the environment.

i) Adequate means for protection against corrosion

An adequate means for protection against corrosion is an approved means for full protection of the core shaft against sea water intrusion and subsequent corrosion attack. Such means are used for the protection of common steel material against corrosion, particularly in combination with water lubricated bearings.

Typical means are, for example:

- continuous metallic, corrosion resistant liners

- continuous cladding
- multiple layer synthetic coating
- multiple layer of fibreglass
- combinations of above mentioned
- rubber/elastomer covering coating.

The means for protection against corrosion are installed/applied according to class approved procedures.

j) Corrosion resistant shaft

Corrosion resistant shaft is made in approved corrosion resistant steel as core material for the shaft.

k) Sterntube sealing system

Sterntube sealing system is the equipment installed on the inboard extremity and, for closed systems, at outboard extremity of the sterntube.

Inboard seal is the device fitted on the fore part of the sterntube that achieves the sealing against the possible leakage of the lubricant media into the ship internal.

Outboard seal is the device fitted on the aft part of the sterntube that achieves the sealing against the possible sea water ingress and the leakage of the lubricant media.

l) Service records

Service records are regularly recorded data showing in-service conditions of the shaft(s) and may include, as applicable: lubricating oil temperature, bearing temperature and oil consumption records (for oil lubricated bearings) or water flow, water temperature, salinity, pH, make-up water and water pressure (for closed loop fresh water lubricated bearings, depending on the design).

m) Oil sample examination

Oil sample examination is a visual examination of the sterntube lubricating oil taken in the presence of the Surveyor, with a focus on water contamination.

n) Lubricating oil analysis

Lubricating oil analysis is to be carried out at regular intervals not exceeding 6 months.

The documentation on lubricating oil analysis is to be available on board.

Oil samples, to be submitted for the analysis, should be taken under service conditions.

o) Fresh water sample test

Fresh water sample test should be carried out at regular intervals not exceeding 6 months

Samples are to be taken under service conditions and are to be representative of the water circulating within the sterntube.

Analysis results are to be retained on board and made available to the Surveyor.

At time of survey, the sample for the test is to be taken in the presence of the Surveyor.

Fresh water sample test shall include the following parameters:

- chlorides content
- pH value
- presence of bearing particles or other particles (only for laboratory analysis, not required for tests carried out in the presence of the Surveyor).

p) Keyless connection

Keyless connection is the forced coupling methodology, between the shaft and the propeller without a key, achieved through the interference fit of the propeller boss on the shaft tapered end.

q) Keyed connection

Keyed connection is the forced coupling methodology, between the shaft and the propeller with a key and a keyway, achieved through the interference fit of the propeller boss on the shaft tapered end.

r) Flanged connection

Flanged connection is the coupling methodology, between the shaft and the propeller, achieved by a flange built-in at the shaft aft end and bolted to the propeller boss.

s) Alternative means

Shafting arrangements such as, but not limited to, an approved Condition Monitoring Scheme an/or other reliable approved means for assessing and monitoring the condition of the tail shaft, bearings, sealing devices and the sterntube lubricant system capable to assure the condition of the propeller shaft assembly with an equivalent level of safety as obtained by survey methods as applicable in [3.2] or [3.3].

3.2 Oil lubricated shafts or closed loop system fresh water lubricated shafts (closed system)

3.2.1 Shaft survey - Method 1

The survey is to consist in:

- Drawing the shaft and examining the entire shaft, seals system and bearings
- For keyed and keyless connections:
 - removing the propeller to expose the forward end of the taper
 - performing a non-destructive examination (NDE) by an approved surface crack detection method all around the shaft in way of the forward portion of the taper section, including the keyway (if fitted). For shaft provided with liners, the NDE shall be extended to the after edge of the liner
- For flanged connection:

Whenever the coupling bolts of any type of flange-connected shaft are removed or the flange radius is made accessible in connection with overhaul, repairs, or when deemed necessary by the Surveyor, the coupling bolts and the flange radius are to be examined by means of an approved surface crack detection method
- Checking and recording the bearing clearances
- Verifying that the propeller is free of damages which may cause the propeller to be out of balance
- Verifying the satisfactory conditions of inboard and outboard seals during reinstallation of the shaft and the propeller
- Recording the bearing wear-down measurements (after reinstallation).

3.2.2 Shaft survey - Method 2

The survey is to consist of:

- For keyed and keyless connections:
 - removing the propeller to expose the forward end of the taper
 - performing a non-destructive examination (NDE) by an approved surface crack detection method all around the shaft in way of the forward portion of the taper section, including the keyway (if fitted)
- For flanged connection:

Whenever the coupling bolts of any type of flange-connected shaft are removed or the flange radius is made accessible in connection with overhaul, repairs, or when deemed necessary by the Surveyor, the coupling bolts and the flange radius are to be examined by means of an approved surface crack detection method

- Checking and recording of the bearing wear-down measurements
- Visual inspection of all the accessible parts of the shafting system
- Verification that the propeller is free of damages which may cause the propeller to be out of balance
- Seal liner found to be or placed in a satisfactory condition
- Verification of the satisfactory reinstallation of the propeller, including verification of the satisfactory conditions of inboard and outboard seals.

Prerequisites, to satisfactorily verify in order to apply method 2, are the following ones:

- Review of service records
- Review of test records of:
 - lubricating oil analysis (for oil lubricated shafts), or
 - fresh water sample test (for closed system fresh water lubricated shafts)
- Oil sample examination (for oil lubricated shafts), or fresh water sample test (for closed system fresh water lubricated shafts)
- Verification of no reported repairs by grinding or welding of shaft and/or propeller.

3.2.3 Shaft survey - Method 3

The survey is to consist of:

- Checking and recording of the bearing wear-down measurements
- Visual inspection of all the accessible parts of the shafting system
- Verification that the propeller is free of damages which may cause the propeller to be out of balance
- Seal liner found to be or placed in a satisfactory condition
- Verification of the satisfactory conditions of inboard and outboard seals.

Prerequisites, to satisfactorily verify in order to apply method 3, are the following ones:

- Review of service records
- Review of test records of:
 - lubricating oil analysis (for oil lubricated shafts), or
 - fresh water sample test (for closed system fresh water lubricated shafts)

- Oil sample examination (for oil lubricated shafts), or fresh water sample test (for closed system fresh water lubricated shafts)
- Verification of no reported repairs by grinding or welding of shaft and/or propeller.

3.2.4 Shaft extension surveys - Extension types

a) Extension up to 2,5 years

The survey is to consist of:

- Checking and recording of the bearing wear-down measurements, as far as practicable
- Visual inspection of all the accessible parts of the shafting system
- Verification that the propeller is free of damages which may cause the propeller to be out of balance
- Verification of the effectiveness of the inboard seal and outboard seals.

Prerequisites, to satisfactorily verify in order to apply extension up to 2,5 years, are the following ones:

- Review of service records
- Review of test records of:
 - lubricating oil analysis (for oil lubricated shafts), or
 - fresh water sample test (for closed system fresh water lubricated shafts)
- Oil sample examination (for oil lubricated shafts), or fresh water sample test (for closed system fresh water lubricated shafts)
- Verification of no reported repairs by grinding or welding of shaft and/or propeller
- Confirmation from the Chief Engineer that the shafting arrangement is in good working condition.

b) Extension up to 1 year

The survey is to consist of:

- Visual inspection of all the accessible parts of the shafting system
- Verification that the propeller is free of damages which may cause the propeller to be out of balance
- Verification of the effectiveness of the inboard seal and outboard seals.

Prerequisites, to satisfactorily verify in order to apply extension up to 1 year, are the following ones:

- Review of the previous wear-down and/or clearance recordings
- Review of service records

- Review of test records of:
 - lubricating oil analysis (for oil lubricated shafts), or
 - fresh water sample test (for closed system fresh water lubricated shafts)
- Oil sample examination (for oil lubricated shafts), or fresh water sample test (for closed system fresh water lubricated shafts)
- Verification of no reported repairs by grinding or welding of shaft and/or propeller
- Confirmation from the Chief Engineer that the shafting arrangement is in good working condition.

c) Extension up to 3 months

The survey is to consist of:

- Visual inspection of all the accessible parts of the shafting system
- Verification of the effectiveness of the inboard seal.

Prerequisites, to satisfactorily verify in order to apply extension up to 3 month, are the following ones:

- Review of the previous wear-down and/or clearance recordings
- Review of service records
- Review of test records of:
 - lubricating oil analysis (for oil lubricated shafts), or
 - fresh water sample test (for closed system fresh water lubricated shafts)
- Oil sample examination (for oil lubricated shafts), or fresh water sample test (for closed system fresh water lubricated shafts)
- Verification of no reported repairs by grinding or welding of shaft and/or propeller
- Confirmation from the Chief Engineer that the shafting arrangement is in good working condition.

3.2.5 Oil lubricated shafts

a) Survey intervals (see Tab 1)

For surveys completed within 3 months before the shaft survey due date, the next period will start from the shaft survey due date.

1) Flanged propeller connection

The following methods are applicable:

- method 1 every 5 years, or
- method 2 every 5 years (prerequisites have to be fulfilled), or
- method 3 every 5 years (prerequisites have to be fulfilled).

2) Keyless propeller connection

The following methods are applicable:

- method 1 every 5 years, or
- method 2 every 5 years (prerequisites have to be fulfilled), or
- method 3 every 5 years (prerequisites have to be fulfilled).

The maximum interval between two surveys carried out according to method 1 or method 2 shall not exceed 15 years, except in the case when one extension for no more than three months is granted.

3) Keyed propeller connection

The following methods are applicable:

- method 1 every 5 years, or
- method 2 every 5 years (prerequisites have to be fulfilled).

b) Survey extensions (see Tab 1)

For all types of propeller connections, the interval between two consecutive surveys may be extended after execution of the extension survey, as follows:

- Extension up to a maximum of 2,5 years
No more than one "2,5 year extension" can be granted. No further extension, of other type, can be granted.
- Extension up to a maximum of 1 year
No more than two consecutive "one year extension" can be granted. In the event an additional extension is requested, the requirements of the "2,5 year extension" are to be carried out and the shaft survey due date, prior to the previous extension(s), is extended for a maximum of 2,5 years.
- Extension up to a maximum of 3 months
No more than one "three month extension" can be granted. In the event an additional extension is requested, the requirements of the "one year extension" or "2,5 year extension" are to be carried out and the shaft survey due date, prior to the previous extension, is extended for a maximum of one year or 2,5 years.

The extension survey should normally be carried out within 1 month of the shaft survey due date and the extension counts from the shaft survey due date.

If the extension survey is carried out more than 1 month prior to the shaft survey due date, then the period of extension counts from the date the extension survey was completed.

Table 1 : Survey intervals for oil lubricated shafts (closed systems)

	Flanged propeller coupling	Keyless propeller coupling	Keyed propeller coupling (2)
Every five years (1)	method 1 or method 2 or method 3	method 1 or method 2 or method 3 (3)	method 1 or method 2
Extension 2,5 Y	yes (4)	yes (4)	yes (4)
Extension 1 Y	yes (5)	yes (5)	yes (5)
Extension 3 M	yes (6)	yes (6)	yes (6)

Note 1: For surveys (method 1, or method 2, or method 3) completed within 3 months before the shaft survey due date, the next period will start from the shaft survey due date.
The extension survey should normally be carried out within 1 month of the shaft survey due date and the extension counts from the shaft survey due date. If the extension survey is carried out more than 1 month prior to the shaft survey due date, then the period of extension counts from the date the extension survey was completed.

(1) Unless an extension type (extension 2,5 Y, or extension 1 Y, or extension 3 M) is applied in between.
(2) Method 3 is not allowed.
(3) The maximum interval between two surveys carried out according to method 1 or method 2 shall not exceed 15 years, except in the case when one extension for no more than three months is granted (i.e. a sequence of surveys carried out according to method 3 cannot exceed a 15-years time interval, plus possibly one extension not exceeding three months).
(4) No more than one “2,5 year extension” can be granted. No further extension, of other type, can be granted.
(5) No more than two consecutive “one year extension” can be granted. In the event an additional extension is requested, the requirements of the “2,5 year extension” are to be carried out and the shaft survey due date, prior to the previous extension(s), is extended for a maximum of 2,5 years.
(6) No more than one “three month extension” can be granted. In the event an additional extension is requested, the requirements of the “one year extension” or “2,5 year extension” are to be carried out and the shaft survey due date, prior to the previous extension, is extended for a maximum of one year or 2,5 years.

3.2.6 Closed loop system fresh water lubricated shafts

The maximum interval between two surveys carried out according to method 1 shall not exceed 15 years. An extension for no more than three months can be granted.

a) Survey intervals (see Tab 2)

For surveys completed within 3 months before the shaft survey due date, the next period will start from the shaft survey due date.

1) Flanged propeller connection

The following methods are applicable:

- method 1 every 5 years, or
- method 2 every 5 years (prerequisites have to be fulfilled), or
- method 3 every 5 years (prerequisites have to be fulfilled).

2) Keyless propeller connection

The following methods are applicable:

- method 1 every 5 years, or
- method 2 every 5 years (prerequisites have to be fulfilled), or
- method 3 every 5 years (prerequisites have to be fulfilled).

3) Keyed propeller connection

The following methods are applicable:

- method 1 every 5 years, or
- method 2 every 5 years (prerequisites have to be fulfilled).

b) Survey extensions (see Tab 2)

For all types of propeller connections, the interval between two consecutive surveys may be extended after execution of the extension survey, as follows:

- Extension up to a maximum of 2,5 years
No more than one “2,5 year extension” can be granted. No further extension, of other type, can be granted.
- Extension up to a maximum of 1 year
No more than two consecutive “one year extension” can be granted. In the event an additional extension is requested, the requirements of the “2,5 year extension” are to be carried out and the shaft survey due date, prior to the previous extension(s), is extended for a maximum of 2,5 years.
- Extension up to a maximum of 3 months
No more than one “three month extension” can be granted. In the event an additional extension is requested, the requirements of the “one year extension” or “2,5 year extension” are to be carried out and the shaft survey due date, prior to the previous extension, is extended for a maximum of one year or 2,5 years.

The extension survey should normally be carried out within 1 month of the shaft survey due date and the extension counts from the shaft survey due date.

If the extension survey is carried out more than 1 month prior to the shaft survey due date, then the period of extension counts from the date the extension survey was completed.

The maximum interval between two surveys carried out according to method 1 shall not exceed 15 years, except in the case when one extension for no more than three months is granted.

Table 2 : Survey intervals for closed loop system fresh water lubricated shafts (closed systems)

	Flanged propeller coupling	Keyless propeller coupling	Keyed propeller coupling (2)
Every five years (1)	method 1 (3) or method 2 or method 3	method 1 (3) or method 2 or method 3	method 1 (3) or method 2
Extension 2,5 Y	yes (4)	yes (4)	yes (4)
Extension 1 Y	yes (5)	yes (5)	yes (5)
Extension 3 M	yes (6)	yes (6)	yes (6)

Note 1: For surveys (method 1, or method 2, or method 3) completed within 3 months before the shaft survey due date, the next period will start from the shaft survey due date.

The extension survey should normally be carried out within 1 month of the shaft survey due date and the extension counts from the shaft survey due date. If the extension survey is carried out more than 1 month prior to the shaft survey due date, then the period of extension counts from the date the extension survey was completed.

(1) Unless an extension type (extension 2,5 Y, or extension 1 Y, or extension 3 M) is applied in between.

(2) Method 3 is not allowed.

(3) The maximum interval between two surveys carried out according to method 1 shall not exceed 15 years.

(4) No more than one "2,5 year extension" can be granted. No further extension, of other type, can be granted.

(5) No more than two consecutive "one year extension" can be granted. In the event an additional extension is requested, the requirements of the "2,5 year extension" are to be carried out and the shaft survey due date, prior to the previous extension(s), is extended for a maximum of 2,5 years.

(6) No more than one "three month extension" can be granted. In the event an additional extension is requested, the requirements of the "one year extension" or "2,5 year extension" are to be carried out and the shaft survey due date, prior to the previous extension, is extended for a maximum of one year or 2,5 years.

3.3 Water lubricated shafts (open systems)

3.3.1 Shaft survey - Method 4

The survey is to consist in:

- Drawing the shaft and examining the entire shaft (including liners, corrosion protection system and stress reducing features, where provided), inboard seal system and bearings
- For keyed and keyless connections:
 - removing the propeller to expose the forward end of the taper
 - performing a non-destructive examination (NDE) by an approved surface crack detection method all around the shaft in way of the forward portion of the taper section, including the keyway (if fitted). For shaft provided with liners, the NDE shall be extended to the after edge of the liner
- For flanged connection:

Whenever the coupling bolts of any type of flange-connected shaft are removed or the flange radius is made accessible in connection with overhaul, repairs, or when deemed necessary by the Surveyor, the coupling bolts and the flange radius are to be examined by means of an approved surface crack detection method

 - Checking and recording the bearing clearances
 - Verifying that the propeller is free of damages which may cause the propeller to be out of balance
 - Verifying the satisfactory conditions of inboard seal during reinstallation of the shaft and the propeller.

3.3.2 Shaft extension surveys - Extension types

a) Extension up to 1 year

The survey is to consist of:

- Visual inspection of all the accessible parts of the shafting system
- Verification that the propeller is free of damages which may cause the propeller to be out of balance
- Checking and recording of the clearances of bearing
- Verification of the effectiveness of the inboard seal.

Prerequisites, to satisfactorily verify in order to apply extension up to 1 year, are the following ones:

- Review of the previous clearance recordings
- Service records
- Verification of no reported repairs by grinding or welding of shaft and/or propeller
- Confirmation from the Chief Engineer that the shafting arrangement is in good working condition.

b) Extension up to 3 months

The survey is to consist of:

- Visual inspection of all the accessible parts of the shafting system
- Verification that the propeller is free of damages which may cause the propeller to be out of balance
- Verification of the effectiveness of the inboard seal.

Prerequisites, to satisfactorily verify in order to apply extension up to 3 months, are the following ones:

- Review of the previous clearance recordings
- Service records
- Verification of no reported repairs by grinding or welding of shaft and/or propeller
- Confirmation from the Chief Engineer that the shafting arrangement is in good working condition.

3.3.3 Shaft survey intervals

a) Survey intervals (see Tab 3)

The following survey intervals according to method 4 are applicable to all types of propeller connections:

- for keyless propeller connections, the maximum interval between two consecutive dismantling and verifications of the shaft cone by means of non-destructive examination (NDE) shall not exceed 15 years
- for surveys completed within 3 months before the shaft survey due date, the next period will start from the shaft survey due date.

1) Configurations allowing 5 year intervals

- single shaft operating exclusively in fresh water
- single shaft provided with adequate means of corrosion protection, single corrosion resistant shaft
- all kinds of multiple shafts arrangements.

2) Other systems

Shaft not belonging to one of the configurations listed in item 1) has to be surveyed according to method 4 every 3 years.

b) Survey extensions (see Tab 3)

For all types of propeller connections, the interval between two consecutive surveys may be extended after execution of the extension survey, as follows:

- Extension up to a maximum of 1 year
No more than one “one year extension” can be granted. No further extension, of other type, can be granted.
- Extension up to a maximum of 3 months
No more than one “three month extension” can be granted. In the event an additional extension is requested, the requirements of the “one year extension” are to be carried out and the shaft survey due date, prior to the previous extension, is extended for a maximum of one year.

The extension survey should normally be carried out within 1 month of the shaft survey due date and the extension counts from the shaft survey due date.

If the extension survey is carried out more than 1 month prior to the shaft survey due date, then the period of extension counts from the date the extension survey was completed.

Table 3 : Survey intervals for water lubricated shafts (open systems)

	All kinds of propeller coupling (4)	
<ul style="list-style-type: none"> • Single shaft operating exclusively in fresh water • Single shaft provided with adequate means of corrosion protection, single corrosion resistant shaft • All kinds of multiple shaft arrangements 	Every five years (1)	Method 4
	Extension 1 Y	yes (2)
	Extension 3 M	yes (3)

	All kinds of propeller coupling (4)	
Other shaft configuration	Every three years (1)	Method 4
	Extension 1 Y	yes (2)
	Extension 3 M	yes (3)

Note 1: For surveys (method 4) completed within 3 months before the shaft survey due date, the next period will start from the shaft survey due date.

The extension survey should normally be carried out within 1 month of the shaft survey due date and the extension counts from the shaft survey due date. If the extension survey is carried out more than 1 month prior to the shaft survey due date, then the period of extension counts from the date the extension survey was completed.

- (1) Unless an extension type (extension 1 Y, or extension 3 M) is applied in between.
- (2) No more than one “one year extension” can be granted. No further extension, of other type, can be granted.
- (3) No more than one “three month extension” can be granted. In the event an additional extension is requested, the requirements of the “one year extension” are to be carried out and the shaft survey due date, prior to the previous extension, is extended for a maximum of one year.
- (4) For keyless propeller connections, the maximum interval between two consecutive dismantling and verifications of the shaft cone by means of non-destructive examination (NDE) shall not exceed 15 years.

SECTION 6

BOILER SURVEY

1 Steam boilers

1.1

1.1.1 Steam boilers, superheaters and economisers are to be examined internally on water-steam side and fire side and externally with the periodicity given in Ch 2, Sec 2, [5.6]. To this end, boilers are to be emptied and suitably prepared for the examination, and the water-steam side and fire side are to be cleaned and cleared of soot. Where necessary, the external surfaces are to be made accessible for inspection by removal of insulation and lining.

1.1.2 Subject to the results of this visual examination, the Surveyor may require:

- non-destructive tests for detection of possible defects in critical areas of plating and shells, pipes and stays
- thickness measurements of plating and shells, furnaces, pipes and stays.

If appropriate, a new working pressure may be fixed by the Society.

When situated inside boiler combustion chambers, steam pipes of cylindrical boilers are to be examined at their ends, and if deemed necessary by the Surveyor, a sample pipe is to be removed for examination.

1.1.3 If the internal examination is not carried out for practicable reasons, the parts subject to pressure are to be submitted to a hydraulic test.

1.1.4 Boiler supports and securing arrangements (fixed and sliding seating, chocks, rolling stays, if any, etc.) are to be examined.

Boiler accessories and mountings (such as valves and studs, water level indicators, safety valves) are to be examined at each survey and opened out as considered necessary by the Society.

Forced circulation pumps of fired steam generators are, wherever possible, to be opened up.

Fuel supply pipes between pumps and burners, fuel tank valves, pipes and deck control gear are to be examined.

1.1.5 When direct visual internal inspection is not feasible due to limited size of the internal spaces, such as for small boilers and/or narrow spaces, this may be replaced by a hydrostatic pressure test or by alternative verifications as determined by the Society.

1.1.6 Upon completion of the internal survey, the boiler is to be examined under steam and fuel oil burners and safety devices checked under working conditions.

The adjustment of the safety valves is to be verified during each boiler internal examination.

Boiler safety valve and its relieving gear are to be examined and tested to verify satisfactory operation.

However, for exhaust gas heated economisers, if steam cannot be raised at port, it is the Chief Engineer's responsibility to set the safety valves at sea and the results are to be recorded in the log book for review by the Society.

1.1.7 Review of the following records since the last boiler survey is to be carried out as part of the survey:

- operation
- maintenance
- repair history
- feedwater chemistry.

1.1.8 In addition to the above requirements, in exhaust gas heated economisers of the shell type, accessible welded joints are to be subjected to a visual examination for cracking. Non-destructive testing may be required for this purpose.

1.1.9 For electrical steam generators, in addition to the above requirements on the water-steam side, the following items are to be verified:

- condition of the electrical insulation resistance of the heating elements
- verification of proper operation and functioning of indication, remote control, automatic alarm and safety devices
- verification of absence of signs of corrosion and leakage of water
- opening-up of forced circulation pumps, wherever possible.

2 Thermal oil heaters

2.1

2.1.1 Thermal oil heaters are to be internally and externally examined. The heater tubes are to be visually examined, and the tightness of the installation (including flange connections, valves and pumps) is to be checked through a test at the working pressure.

2.1.2 Thermal oil heater supports and securing arrangements are to be examined.

Heater accessories and mountings are to be externally and (as needed) internally examined.

Forced circulation pumps are, wherever possible, to be opened up.

Fuel supply pipes between pumps and burners, fuel tank valves, pipes and deck control gear are to be examined.

2.1.3 The following safety devices and instrumentation are to be examined and tested:

- thermal fluid temperature safety device and control
- thermal fluid flow meter
- device for low thermal fluid level in the expansion tank
- other regulation and safety systems.

2.1.4 Where repairs and/or renewal of components exposed to pressure are performed, a pressure test is to be carried out to 1,5 times the working pressure.

2.1.5 Upon completion of the survey, the thermal oil heater is to be examined under working conditions, with particular attention to safety devices and controls of the plant.

SECTION 7

HULL SURVEY FOR NEW CONSTRUCTION

1 General

1.1

1.1.1 In this Section, the Shipbuilder is understood as acting directly or on behalf of the Party requesting classification.

1.1.2 When a hull construction is surveyed by the Society the Shipbuilder is to provide all appropriate evidence required by the Society that the hull is built in compliance with the rules and regulations, taking account of the relevant approved drawings.

1.1.3 For oil tankers and bulk carriers subject to SOLAS Chapter II-1, Part A-1, Regulation 3-10 (goal-based ship construction standards for bulk carriers and oil tankers), the requirements as referred to in Article [6] and sub-articles [3.2] and [5.2] are applicable.

2 Documentation to be available for the Surveyor during construction

2.1

2.1.1 During the construction, the Shipbuilder is to provide the Surveyors access to documentation required by the Society; this includes documentation retained by the Shipbuilder or other third parties.

2.1.2 The list of documents approved or reviewed by the Society for the specific new construction are to be made available by the Shipbuilder in due time for the Society during the construction as follows:

- a) plans and supporting documents required in Ch 2, Sec 1, [2.3]
- b) examination and testing plans
- c) NDE plans
- d) welding consumable details
- e) welding procedures specifications & welding procedures qualification records
- f) welding plan or details
- g) welder's qualification records
- h) NDE operators qualification records
- i) hot spot map of the structure, when additional class notation **VeriSTAR-HULL CM** is assigned.

2.1.3 As required, evidence of compliance with Ch 2, Sec 1, [2.1.5] is also to be made available by the Shipbuilder to the Surveyor whilst the construction process proceeds to prove

that the material and equipment supplied to the ship has been built or manufactured under survey relevant to the classification rules and delegated statutory requirements.

3 Ship construction file

3.1 Ship Construction File (SCF) for all ships, except those specified in [1.1.3]

3.1.1 The Shipbuilder is to deliver documents for the Ship Construction File. In the event that items have been provided by another Party such as the Shipowner and where separate arrangement have been made for document delivery which excludes the Shipbuilder, that Party has the responsibility.

The Ship Construction File shall be reviewed for content in accordance with the requirements of [3.1.3].

3.1.2 The Ship Construction File is to be placed on board the ship by the Shipbuilder to facilitate operation, maintenance, survey and repair.

3.1.3 The Ship Construction File is to include but not limited to:

- as-built structural drawings including scantling details, material details, and, as applicable, wastage allowances, location of butts and seams, cross section details and locations of all partial and full penetration welds, areas identified for close attention and rudders (Refer to Part A, Chapter 3 and Part A, Chapter 4)
- manuals required for classification and statutory requirements, e.g. loading and stability, bow doors and inner doors and side shell doors and stern doors – operations and maintenance manuals (Refer to Pt B, Ch 8, Sec 5, [8] and Pt B, Ch 8, Sec 6, [7])
- ship structure access manual, as applicable
- copies of certificates of forgings and castings welded into the hull (Refer to NR 216 Materials and Welding)
- details of equipment forming part of the watertight and weather tight integrity of the ship
- a Cable Transit Seal Systems Register, to be prepared by the shipbuilder for watertight cable transits. The Register can be in either a hard copy or digitized media. It is to include a marking / identification system, documentation referencing manufacturer manual(s) for each type of cable transit installed, the Type Approval certification for each type of transit system, applicable installation drawings, and a recording of each installed transit documenting the as built condition after final inspection in the shipyard. This is to include sections to record any inspection, modification, repair and maintenance
- tank testing plan including details of the test requirements (Refer to Pt B, Ch 11, Sec 4)

- corrosion protection specifications (Refer to Ch 4, Sec 2, Pt B, Ch 10, Sec 1 and Pt D, Ch 4, Sec 3)
- details for the in-water survey, if applicable, information for divers, clearances measurements instructions etc., tank and compartment boundaries
- docking plan and details of all penetrations normally examined at drydocking
- Coating Technical File, for ships subject to compliance with the IMO Performance Standard for Protective Coatings (PSPC) and for ships assigned with the additional service feature/additional class notation **CPS(WBT)**.

3.2 Ship Construction File (SCF) for ships as specified in [1.1.3]

3.2.1 A Ship Construction File (SCF) with specific information on how the functional requirements of the goal-based ship construction standards for bulk carriers and oil tankers have been applied in the ship design and construction is to be provided upon delivery of a new ship, and kept on board the ship and/or ashore and updated as appropriate throughout the ship's service. The content of the Ship Construction File is to conform to the requirements as specified in [3.2.2].

3.2.2 The following design specific information is to be included in the Ship Construction File (SCF):

- areas requiring special attention throughout the ship's life (including the critical structural areas)
- all design parameters limiting the operation of a ship
- any alternatives to the rules, including structural details and equivalency calculations
- "as-built" drawings and information which are verified to incorporate all alterations approved by the recognized organization or flag State during the construction process including scantling details, material details, location of butts and seams, cross-section details and locations of all partial and full penetration welds
- net (renewal) scantlings for all the structural constituent parts, as-built scantlings and voluntary addition thicknesses (refer to Part A, Chapter 3 and Part A, Chapter 4)
- minimum hull girder section modulus along the length of the ship which has to be maintained throughout the ship's life, including cross-section details such as the value of the area of the deck and bottom zones, the renewal value for the neutral axis zone (refer to Part A, Chapter 3)
- a listing of the materials used for construction of the hull structure and provisions for documenting changes to any of the above during the ship's service life
- copies of the certificates of forgings and castings welded into the hull (refer to NR216 Materials and Welding)
- details of the equipment forming part of the watertight and weathertight integrity of the ship
- a Cable Transit Seal Systems Register, to be prepared by the shipbuilder for watertight cable transits. The Register can be in either a hard copy or digitized media. It is to include a marking / identification system, documentation referencing manufacturer manual(s) for each type of cable transit installed, the Type Approval certification for each type of transit system, applicable installation

drawings, and a recording of each installed transit documenting the as built condition after final inspection in the shipyard. This is to include sections to record any inspection, modification, repair and maintenance.

- tank testing plan, including details of the test requirements (refer to Pt B, Ch 11, Sec 4)
- details for the in-water survey, when applicable, information for the divers, clearance measurement instructions etc., tank and compartment boundaries
- docking plan and details of all penetrations normally examined at drydocking
- Coating Technical File, for ships subject to compliance with the IMO Performance Standard for Protective Coatings (PSPC), see Note 1.

Note 1: PSPC means Performance Standard for Protective Coatings:

- for dedicated seawater ballast tanks in all types of ships and double-side skin spaces of bulk carriers, adopted by IMO Res. MSC.215(82), as amended, and
- for cargo oil tanks of crude oil tankers, adopted by IMO Res. MSC.288(87), as amended.

3.2.3 Refer to Tab 1 for details of information to be further included. This information is to be kept on board the ship and/or ashore and updated as appropriate, throughout the ship's life, in order to facilitate safe operation, maintenance, survey, repair and emergency measures.

3.2.4 It is to be noted that parts of the SCF content may be subject to various degrees of restricted access and that such documentation may be appropriately kept ashore.

3.2.5 The SCF is to include the list of the documents constituting the SCF and all information, listed in Tab 1, which is required for a ship's safe operation, maintenance, survey, repair and in emergency situations. Details of specific information that is not considered to be critical to safety might be included, directly or by reference, to the other documents.

3.2.6 When developing a SCF, all the columns in Tab 1 are to be reviewed to ensure that all necessary information has been provided.

3.2.7 It may be possible to provide information listed in this sub-article under more than one Tier II item (see Note 1) as a single item within the SCF; for example, the Coating Technical File required by the PSPC (see Note 1 of [3.2.2]) is relevant for both "Coating life" and "Survey during construction".

Note 1: Tier II items means the functional requirements included in the International Goal-based Ship Construction Standards for Bulk Carriers and Oil Tankers (GBS), adopted by IMO Res. MSC.287(87).

3.2.8 The SCF is to remain with the ship and, in addition, be available to the Society and flag State throughout the ship's life. Where information not considered necessary to be on board is stored ashore, procedures to access this information are to be specified in the onboard SCF. The intellectual property provisions within the SCF are to be duly complied with.

3.2.9 The SCF should be updated throughout the ship's life at any major event, including, but not limited to, substantial repair and conversion, or any modification to the ship structure.

Table 1 : List of Information to be Included in the Ship Construction File (SCF)

Tier II items		Information to be included	Further explanation of the content	Example documents	Normal storage location*
DESIGN					
1	Design life	<ul style="list-style-type: none"> assumed design life, in years 	<ul style="list-style-type: none"> statement or note on midship section 	<ul style="list-style-type: none"> SCF-specific (1) midship section plan 	on board on board
2	Environmental conditions	<ul style="list-style-type: none"> assumed environmental conditions 	<ul style="list-style-type: none"> statement referencing data source or Rule (specific rule and data), or in accordance with Rule (date and revision) 	<ul style="list-style-type: none"> SCF-specific (1) 	on board
3 Structural strength					
3.1	General design	<ul style="list-style-type: none"> applied Rule (date and revision) applied alternative to Rule 	<ul style="list-style-type: none"> applied design method alternative to Rule and subject structure(s) 	<ul style="list-style-type: none"> SCF-specific (1) 	on board
3.2	Deformation and failure modes	<ul style="list-style-type: none"> calculating conditions and results; assumed loading conditions 	<ul style="list-style-type: none"> allowable loading pattern maximum allowable hull girder bending moment and shear force 	<ul style="list-style-type: none"> capacity plan loading manual trim and stability booklet 	on board on board
3.3	Ultimate strength	<ul style="list-style-type: none"> operational restrictions due to structural strength 	<ul style="list-style-type: none"> maximum allowable cargo density or storage factor 	<ul style="list-style-type: none"> loading instrument instruction manual operation and maintenance manuals 	on board on board
3.4	Safety margins	<ul style="list-style-type: none"> strength calculation results gross hull girder section modulus minimum hull girder section modulus along the length of the ship to be maintained throughout the ship's life, including cross section details such as the value of the area of the deck zone and bottom zone, the renewal value for the neutral axis zone gross scantlings of structural constituent parts net scantlings of structural constituent parts, as built scantlings and voluntary addition thicknesses hull form (4) 	<ul style="list-style-type: none"> bulky output of strength calculation plan showing highly stressed areas (e.g. critical structural areas) prone to yielding and/or buckling structural drawings rudder and stern frame structural details of typical members hull form information indicated in key construction plans (2) hull form data stored within an onboard computer necessary for trim and stability and longitudinal strength calculations 	<ul style="list-style-type: none"> strength calculation areas prone to yielding and/or buckling general arrangement plan key construction plans (2) rudder and rudder stock plans structural details yard plans (3) dangerous area plan lines plan (5), or equivalent (6) 	on shore on board on board on board on board

Tier II items		Information to be included	Further explanation of the content	Example documents	Normal storage location*
4	Fatigue life	<ul style="list-style-type: none"> applied Rule (date and revision) applied alternative to Rule calculating conditions and results; assumed loading conditions fatigue life calculation results 	<ul style="list-style-type: none"> applied design method alternative to Rule and subject structure(s) assumed loading conditions and rates bulky output of fatigue life calculation plan showing areas (e.g. critical structural areas) prone to fatigue 	<ul style="list-style-type: none"> SCF-specific (1) structural details fatigue life calculation areas prone to fatigue 	<p>on board</p> <p>on board</p> <p>on shore</p> <p>on board</p>
5	Residual strength	<ul style="list-style-type: none"> applied Rule (date and revision) 		<ul style="list-style-type: none"> SCF-specific (1) 	on board
6 Protection against corrosion					
6.1	Coating life	<ul style="list-style-type: none"> coated areas and target coating life and other measures for corrosion protection in holds, cargo and ballast tanks, other structure-integrated deep tanks and void spaces specification for coating and other measures for corrosion protection in holds, cargo and ballast tanks, other structure-integrated deep tanks and void spaces gross scantlings of structural constituent parts net scantlings of structural constituent parts, as built scantlings and voluntary addition thicknesses 	<ul style="list-style-type: none"> plans showing areas (e.g. critical structural areas) prone to excessive corrosion 	<ul style="list-style-type: none"> SCF-specific (1) Coating Technical File required by PSPC (7) areas prone to excessive corrosion key construction plans (2) 	<p>on board</p> <p>on board</p> <p>on board</p> <p>on board</p>
6.2	Corrosion addition				
7	Structural redundancy	<ul style="list-style-type: none"> applied Rule (date and revision) 		<ul style="list-style-type: none"> SCF-specific (1) 	on board
8	Watertight and weathertight integrity	<ul style="list-style-type: none"> applied Rule (date and revision) key factors for watertight and weathertight integrity 	<ul style="list-style-type: none"> details of equipment forming part of the watertight and weathertight integrity 	<ul style="list-style-type: none"> SCF-specific (1) structural details of hatch covers, doors and other closings integral with the shell and bulkheads 	<p>on board</p> <p>on board</p>
9	Human element considerations	<ul style="list-style-type: none"> list of ergonomic design principles applied to ship structure design to enhance safety during operations, inspections and maintenance of ship 		<ul style="list-style-type: none"> SCF-specific (1) 	on board
10	Design transparency	<ul style="list-style-type: none"> applied Rule (date and revision) applicable industry standards for design transparency and IP protection reference to part of SCF information kept ashore 		<ul style="list-style-type: none"> intellectual property provisions summary, location and access procedure for part of SCF information on shore 	<p>on board</p> <p>on board</p>

Tier II items	Information to be included	Further explanation of the content	Example documents	Normal storage location*	
CONSTRUCTION					
11	Construction quality procedures	<ul style="list-style-type: none"> applied construction quality standard 	<ul style="list-style-type: none"> recognized national or international construction quality standard 	<ul style="list-style-type: none"> SCF-specific (1) 	on board
12	Survey during construction	<ul style="list-style-type: none"> survey regime applied during construction (to include all owner and class scheduled inspections during construction) information on non-destructive examination 	<ul style="list-style-type: none"> applied Rules (date and revision) copies of certificates of forgings and castings welded into the hull 	<ul style="list-style-type: none"> SCF-specific (1) tank testing plan non-destructive testing plan Coating Technical File required by PSPC (7) 	on board on board on board on board
IN-SERVICE CONSIDERATIONS					
13	Survey and maintenance	<ul style="list-style-type: none"> maintenance plans specific to the structure of the ship where higher attention is called for preparations for survey gross hull girder section modulus minimum hull girder section modulus along the length of the ship to be maintained throughout the ship's life, including cross-section details such as the value of the area of the deck zone and bottom zone, the renewal value for the neutral axis zone gross scantlings of structural constituent parts net scantlings of structural constituent parts, as built scantlings and voluntary addition thicknesses hull form (4) 	<ul style="list-style-type: none"> plan showing highly stressed areas (e.g. critical structural areas) prone to yielding, buckling, fatigue and/or excessive corrosion arrangement and details of all penetrations normally examined at dry-docking details for dry-docking details for in-water survey hull form information indicated in key construction plans (2) 	<ul style="list-style-type: none"> SCF-specific (1) operation and maintenance manuals (e.g. hatch covers and doors) docking plan dangerous area plan Ship Structure Access Manual means of access to other structure-integrated deep tanks Coating Technical File required by PSPC (7) key construction plans (2) rudder and rudder stock structural details yard plans (3) lines plan (5), or equivalent (6) 	on board on board on board on board on board on board on board on board on board on board on board

	Tier II items	Information to be included	Further explanation of the content	Example documents	Normal storage location*
14	Structural accessibility	<ul style="list-style-type: none"> means of access to holds, cargo and ballast tanks and other structure-integrated deep tanks 	<ul style="list-style-type: none"> plans showing arrangement and details of means of access 	<ul style="list-style-type: none"> Ship Structure Access Manual means of access to other structure-integrated deep tanks 	<ul style="list-style-type: none"> on board on board
RECYCLING CONSIDERATIONS					
15	Recycling	<ul style="list-style-type: none"> identification of all materials that were used in construction and may need special handling due to environmental and safety concerns 	<ul style="list-style-type: none"> list of materials used for the construction of the hull structure 	<ul style="list-style-type: none"> SCF-specific (1) 	<ul style="list-style-type: none"> on board
<p>* Normal storage location means a standard location where each SCF information item should be stored. However, those items listed as being on board should be on board as a minimum to ensure that they are transferred with the ship on a change of owner. on board = on board ship; on shore = on shore archive. Shore archive is to be operated in accordance with applicable international standards.</p> <p>(1) SCF-specific means documents to be developed especially to meet the requirements of these GBS guidelines (MSC.1/Circ.1343).</p> <p>(2) Key construction plans means plans such as midship section, main O.T. and W.T. transverse bulkheads, construction profiles/plans, shell expansions, forward and aft sections in cargo tank (or hold) region, engine-room construction, forward construction and stern construction drawings.</p> <p>(3) Yard plans means a full set of structural drawings, which include scantling information of all structural members.</p> <p>(4) Hull form means a graphical or numerical representation of the geometry of the hull. Examples would include the graphical description provided by a lines plan and the numerical description provided by the hull form data stored within an onboard computer.</p> <p>(5) Lines plan means a special drawing which is dedicated to show the entire hull form of a ship.</p> <p>(6) Equivalent (to Lines plan) means a set of information of hull form to be indicated in key construction plans for SCF purposes. Sufficient information should be included in the drawings to provide the geometric definition to facilitate the repair of any part of the hull structure.</p> <p>(7) PSPC means Performance Standard for Protective Coatings for dedicated seawater ballast tanks in all types of ships and double-side skin spaces of bulk carriers, adopted by IMO Resolution MSC.215(82), as amended and Performance Standard for Protective Coatings for cargo oil tanks of crude oil tankers, adopted by IMO Resolution MSC.288(87), as amended.</p>					

3.2.10 The SCF shall be reviewed, at the time of new building, in accordance with the requirements of [3.2.2] and [3.2.3] and the normal storage location shall be distinguished.

Note 1: "Reviewed" means the examination of the SCF that is carried out by the Surveyor, at the end of the newbuilding process, in order to confirm that:

- drawings and documents required under [3.2]
- the possible additional drawings/documents provided by the shipyard, as per the Ship Construction File (SCF) list of drawings/documents

are present in the copies of the SCF stored on board and in the ashore archive.

The "review" is not to be intended as an assessment of the drawings/documents in order to verify their compliances with the applicable Rules/Regulations.

3.2.11 For the SCF stored on board ship, the Surveyor is to verify that the information is placed on board the ship, upon completion of ship construction.

3.2.12 For the SCF stored on shore archive, the Surveyor is to verify that the information is stored on shore archive by examining the list of information included on shore archive, upon completion of ship construction.

4 Newbuilding survey planning

4.1

4.1.1 Prior to commencement of surveys for any newbuilding project, the Shipbuilder is to discuss with the Society at a kick-off meeting the items of specific activities which are relevant to the shipbuilding functions listed in the kick-off meeting templates given in NR540 "Kick-off Meeting Templates for Newbuilding". The purpose of the meeting is to review and agree how the listed items are to be addressed. The meeting is to take into account the Shipbuilder construction facilities and ship type including the list of proposed subcontractors. This list is not exhaustive and can be modified to reflect the construction facilities or specific ship type. A record of the meeting is normally to be prepared and updated by the Shipbuilder, based upon the content of the kick-off meeting templates. The Shipbuilder should agree to undertake ad hoc investigations during construction as may be requested by the Society where areas of concern arise and to keep the Society advised of the progress of any investigation. Whenever an investigation is undertaken, the Shipbuilder is, in principle, to agree to suspend relevant construction activities if warranted by the severity of the problem. The records are to take note of specific published

Administration requirements and interpretations of statutory requirements.

4.1.2 The shipyard shall be requested to advise of any changes to the activities agreed at the kick off meeting and these are to be documented in the survey plan. E.g. if the Shipbuilder chooses to use or change sub-contractors, or to incorporate any modification necessitated by changes in production or inspection methods, rules and regulations, structural modifications, or in the event where increased inspection requirements are deemed necessary as a result of a substantial non-conformance or otherwise.

4.1.3 Shipbuilding quality standards for hull structure during new construction are to be reviewed and agreed during the kick-off meeting. Structural fabrication is to be carried out in accordance with IACS Recommendation 47, "Shipbuilding and Repair Quality Standard", or a Recognized Fabrication Standard (RFS) which has been accepted by the Society prior to the commencement of fabrication/construction (Refer to Pt B, Ch 11, Sec 1, [1.1.4]). The work is to be carried out in accordance with these Rules and under survey of the Society.

The Society may accept an RFS as an alternative to IACS Recommendation 47 provided that [4.1.4] or [4.1.5] is complied with as applicable.

4.1.4 Where a RFS is well established and has well documented history (3 or more years prior to the new vessel contract) of successful application to similar designs as the new vessel and that history is for the same Shipyard as the new vessel. Then the Shipyard is to create a summary document referencing the RFS to be used in construction and highlighting any limitations to usage of the selected RFS. This summary document is to be included with the "record of kick-off meeting" for the vessel.

The summary document is also to be included in the SCF, (for Tankers and Bulk Carriers subject to SOLAS Chapter II-1 Part A-1 Regulation 3-10 per App 2, Table A Tier II Item 11), as applicable.

4.1.5 Where a RFS is new or revised or otherwise not as per [4.1.4], the following steps are to be carried out:

- a) the tolerances and fabrications standards of the RFS are to be compared with those of Recommendation 47. Any that are less stringent than those of Recommendation 47 are to be identified.
- b) the tolerances and fabrication standards of the RFS identified in [4.1.5](a) are to be assessed to determine the acceptability for use and/or any restrictions for usage for the subject (or proposed) design. Details of how the acceptability for use and/or restrictions are to be recorded, and,
- c) a summary document including the outcomes of [4.1.5](a) and [4.1.5](b) is to be compiled. This document is to also include a reference to the RFS, details of the tolerance and fabrication standards not analysed as part of [4.1.5](b) and any limitations to the usage of the RFS.

The summary document is to be included with the "record of the kick-off meeting" of the vessel. The summary document is also to be included in the SCF, (for Tankers and Bulk Carriers subject to SOLAS Chapter II-1 Part A-1 Regulation 3-10 per App 2, Table A Tier II Item 11), as applicable.

4.1.6 The kick-off meeting may be attended by other Parties (Owner, Administrations...) subject to agreement by the shipbuilder.

4.1.7 In the event of series ship production, the requirement for a kick off meeting may be waived for the second and subsequent ships provided that no changes to the specific activities agreed in the kick off meeting for the first ship are introduced. If any changes are introduced, these are to be agreed in a new dedicated meeting and documented in a record of such meeting.

5 Examination and test plan for newbuilding activities

5.1 Applicable to all ships

5.1.1 The Shipbuilder is to provide to the Surveyor plans of the items which are intended to be examined and tested. These plans need not be submitted for approval and examination at the time of the kick-off meeting. They are to include:

- proposal for the examination of completed steelwork generally referred to as the block plan and are to include details of joining blocks together at the pre-erection and erection stages or at other relevant stages
- proposal for fit up examinations where necessary
- proposal for testing of the structure (leak and hydrostatic) as well as for all watertight and weathertight closing appliances
- proposal for non-destructive examination
- any other proposal specific to the ship type or to the delegated statutory requirements.

5.1.2 The plans and any modification to them are to be submitted to the Surveyors in sufficient time to allow review before the relevant survey activity commences.

5.2 Applicable for ships as specified in [1.1.3]

5.2.1 In addition to [5.1.1], the Shipbuilder is to provide plans of the items which are intended to be examined and tested in accordance with the Rules in a document known as the Survey Plan, taking into account the ship type and design. This Survey Plan is to be reviewed at the time of the kick-off meeting, and is to include:

- A set of requirements, specifying the extent and scope of the construction survey(s) and identifying areas that need special attention during the survey(s), to ensure compliance of construction with mandatory ship construction standards, including:
 - types of surveys (visual, non-destructive examination, etc.) depending on the location, materials, welding, casting, coatings, etc.

- establishment of a construction survey schedule for all the assembly stages from the kick-off meeting, through all major construction phases, up to delivery
- inspection/survey plan, including provisions for the critical areas identified during design approval
- inspection criteria for acceptance
- interaction with shipyard, including notification and documentation of survey results
- correction procedures to remedy the construction defects
- list of the items that would require scheduling or formal surveys
- determination and documentation of the areas that need special attention throughout ship's life, including criteria used in making the determination

- A description of the requirements for all types of testing during survey, including test criteria.

6 Design transparency

6.1 Applicable for ships as specified in [1.1.3]

6.1.1 For ships subject to compliance with IMO Res. MSC.287(87), IMO Res. MSC.290(87), IMO Res. MSC.296(87) and IMO MSC.1/Circ.1343, readily available documentation is to include the main goal-based parameters and all relevant design parameters that may limit the operation of the ship.

6.1.2 The Shipyard or the Designer is to authorize the Society to make available relevant technical correspondence in relation with the SCF to Owners and Flag states.

SECTION 8

SURVEY OF WATERTIGHT CABLE TRANSITS

1 General

1.1 Application

1.1.1 The requirements of this Section apply to all vessels contracted for construction on or after 1st July 2021 and are in addition to the requirements of Ch 2, Sec 2; Ch 3, Sec 1; Ch 3, Sec 2; Ch 3, Sec 3 and Ch 3, Sec 7.

1.1.2 Watertight cable transits are to be installed and maintained in accordance with the manufacturer's requirements and in accordance with the requirements of the relevant Type Approval certification.

2 Cable Transit Seal Systems Register

2.1 New construction

2.1.1 A Cable Transit Seal Systems Register is to be provided by the shipbuilder for all watertight cable transits fitted to the vessel. The Cable Transit Seal Systems Register can be in either a hard copy or digitized media. It is to include a marking / identification system, documentation referencing manufacturer manual(s) for each type of cable transit installed, the Type Approval certification for each type of transit system, applicable installation drawings, and a recording of each installed transit documenting the as built condition after final inspection in the shipyard. It is to include sections to record any inspection, modification, repair and maintenance.

2.1.2 The Cable Transit Seal Systems Register is to be reviewed by the attending Surveyor to confirm it contains a

list of the watertight cable transits, applicable cable transit information and sections to maintain in-service maintenance and survey records.

2.1.3 For manned vessels, the Cable Transit Seal Systems Register is to be held onboard of the vessel. For unmanned vessels, if a suitable storage location does not exist onboard, the Register may be held ashore. The Cable Transit Seal Systems Register is to be readily available for the attending surveyor.

2.2 Vessel in service

2.2.1 The owner is to maintain the Cable Transit Seal Systems Register to record any disruption (repair, modification or opening out and closing) to a cable transit or to record the installation of a new cable transit.

3 Installation and maintenance of Watertight Cable transits

3.1

3.1.1 At new construction and periodic surveys it is to be confirmed that:

- cable transits have been installed, and where disrupted have been reinstated, in accordance with the manufacturer's requirements and in accordance with the requirements of Type Approval
- where specified, appropriate specialized tools have been used.

APPENDIX 1

CLASS REQUIREMENTS AND SURVEYS OF LAID-UP SHIPS

1 General

1.1

1.1.1 In order to maintain its class during a normal operation period, a ship is to be submitted to the surveys described in Ch 2, Sec 2 at their due dates and to the satisfaction of the Society, and is to be free of overdue surveys and conditions of class during the considered period.

1.1.2 When a ship stops trading and is put out of commission for a certain period, i.e. is laid-up, the normal survey requirements may no longer apply provided that the Owner notifies the Society of this fact. The Owner is also to submit a lay-up maintenance program to the Society for approval.

1.1.3 The lay-up maintenance program includes:

- the safety conditions to be kept throughout the lay-up period
- the measures taken to preserve the maintenance of the ship throughout the lay-up period
- the survey requirements to be complied with for lay-up, maintenance of class in lay-up and re-commissioning.

2 Safety conditions

2.1

2.1.1 Power supply

Adequate power supply is to be supplied, or readily available, all around the clock, either from independent means on board the ship or from shore.

The following safety conditions are to be kept throughout the lay-up period.

2.1.2 Manning

Watch personnel are to be provided. The number of the watch personnel will depend on the size of the ship, the lay-up site and mooring arrangements, the shore assistance available in case of fire, leakage or flooding, the maintenance required to provide adequate preservation. A permanent shore communication installation (radio, telephone) is also to be available.

2.1.3 Fire protection and fire fighting

The following is to be complied with:

- automatic fire alarm systems, where provided, are to be in working order and in operation
- fire-fighting installations are to be tested regularly and readily available

- the fire main is to be readily available and periodically tested under pressure
- ventilation trunks, air inlets and watertight doors are to be kept closed.

2.1.4 Protection against explosion

Cargo spaces and piping systems are to be cleaned and ventilated to prevent gas from forming any pockets.

An inert gas system in operation is recommended for the cargo spaces of oil and chemical tankers.

All flammable materials, sludge, etc. are to be removed from the ship's bilge, tank tops, double bottom tanks, engine room, pump rooms and similar spaces.

Hot work is not to be carried out during lay-up, unless special precautionary measures are taken.

2.1.5 Safety equipment

All the equipment usually recommended for the safety of the watch personnel is to be provided, kept in working order and tested regularly.

The usual life-saving equipment such as liferafts, life-buoys, breathing apparatus, oxygen masks and distress signals is to be provided and made accessible.

The requirements of the flag Administration and of the local port authorities of the lay-up site are usually to be applied.

2.1.6 Emergency power

The emergency source of power, emergency generator and/or emergency air compressor are to be kept in working order and tested weekly.

3 Preservation measures for lay-up and maintenance

3.1 General

3.1.1 A lay-up log-book is to be kept on board, in which the maintenance work and tests carried out during the lay-up period are to be entered with the corresponding dates. The nature and frequency of the maintenance, inspections and tests are also to be defined in the lay-up log book.

3.1.2 The following measures for preservation and maintenance during the lay-up period are to be taken by Owners according to the type of ship, hull equipment, machinery installations and the specific cases of lay-up conditions.

3.2 Exposed parts of the hull

3.2.1 Underwater parts of the hull are to be protected against corrosion. It is advisable to provide an impressed current cathodic protection system where the quantity of corrosive waste discharge is particularly high. When such systems are provided they are to be serviced and checked at regular intervals. The condition of sacrificial anodes is to be evaluated at the annual lay-up condition surveys.

3.2.2 The coating of the hull above the waterline, exposed decks, access doors or covers on exposed decks, and hatch covers is to be maintained in satisfactory condition.

All accesses leading to internal spaces are to be kept closed.

All vent pipes and ventilation trunks are to be kept closed.

3.3 Internal spaces

3.3.1 Cargo tanks and cargo holds are to be emptied, cleaned and kept dry.

Ballast tanks are to be kept either full or empty. When ballast spaces are kept filled with sea water, special care is to be taken to keep such spaces topped up and protected against corrosion. When provided, sacrificial anodes are to be renewed when deemed necessary. The topping up is to be regularly verified.

3.3.2 Chain lockers are to be drained, cleaned and kept dry. Coating with bituminous paint is recommended.

3.3.3 Fuel oil and lubricating oil tanks are to be drained regularly.

Lubricating oil analysis is to be performed regularly and the oil renewed when the result is not satisfactory. Prior to being refilled, tanks are to be cleaned.

Empty lubricating oil tanks are to be cleaned and kept dry.

Fresh water or distilled water tanks are to be kept full or empty. Empty tanks are to be cleaned and kept dry. Where cement wash is used as a protective sheathing, this is to be examined and repaired prior to filling.

3.3.4 The bilge and tank top in engine rooms are to be cleaned and kept dry.

Hull sea inlet and outlet valves not in use are to be kept closed.

3.4 Deck fittings

3.4.1 The windlass, capstans and winches are to be regularly greased and turned once a week.

All wire cables are to be kept greased.

Visible parts of chains are to be coal-tarred and examined regularly.

Chocks and hawse pipes are to be coated with bituminous paint or equivalent if deemed necessary.

Cargo piping on deck is to be drained, blown through if deemed necessary and kept dry by opening up drains.

Electrical machinery and navigational equipment are to be protected by watertight covers.

3.5 Machinery

3.5.1 Machinery spaces

The air temperature inside the machinery spaces is normally to be kept above 0°C.

Humidity is to be kept as low as possible and within acceptable limits.

3.5.2 Machinery - General

Exposed mechanical parts of machinery are to be greased.

All rotating machinery such as diesel engines, reciprocating engines, pumps, turbines, electric motors and generators are to be turned at regular intervals with a limited number of revolutions (the lubricating oil system should be put in operation or proper priming applied). Units are not to be stopped in the same position as the previous one.

Bearing boxes are to be emptied, cleaned and refilled with new oil.

3.5.3 Main turbines

Turbines are to be kept dry.

All steam inlets are to be sealed.

Expansion arrangements (sliding feet) are to be suitably greased.

Electric heaters are to be put inside the turbines. Heat drying is to be made in open circuit, all valves shut and gland closing devices withdrawn.

Turbines are to be turned weekly, the lubricating oil system being put in service. The shaft line is to be stopped after turning an integer number of revolutions plus one quarter of a revolution.

3.5.4 Reduction gears

For large reduction gears, a fan activating the circulation of hot air in closed circuit with air hoses is to be fitted (intake at lower part of casing and discharge at upper part).

3.5.5 Auxiliary turbine-driven machinery

Stators are to be drained and kept dry.

Shaft sealing glands are to be lubricated.

Lubricating oil is to be analysed and renewed when deemed necessary. Prior to oil renewal, the oil casings are to be cleaned.

Exhaust steam pipes are to be kept dry.

Stuffing boxes are to be dismantled.

Turbines are to be turned weekly an integer number of revolutions plus one quarter of a revolution.

3.5.6 Condensers and heat exchangers

Condensers and heat exchangers are to be drained and kept dry.

Desiccant is to be placed in steam spaces.

Water sides are to be washed with fresh water.

The condition of the zinc anodes is to be periodically checked.

When tubes are fitted with plastic or fibre packing, water sides are to be filled with alkaline distilled water.

When tubes are expanded or fitted with metal packing, water sides are to be provided with desiccants and kept dry.

3.5.7 Auxiliary machinery

Air receivers are to be drained, opened up and cleaned. Pressure relief valves are to be cleaned and slightly lubricated.

Air compressor crankcases are to be drained, cleaned and refilled with clean oil. Cylinders and valves are to be lubricated. Coolers are to be drained and dried. Air drains are to be opened and the system dried.

Air start lines are to be drained and dried.

Hot-wells/return tanks are to be drained and dried.

De-aerators are to be drained and dried.

Feed pumps and extraction pumps are to be drained and dried.

Air ejectors are to be drained and dried.

Main circulation pumps are to be drained and dried.

Evaporators are to be drained, cleaned and dried.

3.5.8 Piping

Pipes not in use are to be drained and kept dry.

3.5.9 Diesel engines

Daily tank fuel oil outlet pipes and all injection equipment are to be filled with filtered gas oil.

Fresh water circuits are to be filled with water mixed with rust inhibitors. Fresh water pH is to be checked monthly.

Oil of hydraulic regulators is to be replaced.

Sea water cooling pipes are to be drained.

Crankcases are to be provided with desiccant.

Starting valves are to be lubricated (internally and externally).

Motor oil is to be sprayed in cylinders and on all external parts liable to corrosion.

Cams and cylinders are to be motor oil sprayed monthly.

Turbo-compressor/charger ball bearings are to be oil sprayed and rotated for an integer number of revolutions plus one quarter of a revolution.

Engine air inlets and exhaust gas pipes are to be sealed.

Scavenge spaces are to be cleaned

Engines are to be turned weekly.

3.5.10 Shaft lines

Shaft lines are to be coated with grease.

Shaft bearing cooling pipes are to be drained.

For sea water lubricated propeller shafts, the packing gland of the engine room stuffing box is to be tightened.

For oil lubricated stern tubes, lubricating oil is to be analysed and renewed if not satisfactory. The oil level in the tank is to be verified regularly.

Propeller shaft lines are to be rotated an integer number of revolutions plus one quarter of a revolution.

3.6 Electrical installations

3.6.1 Main and secondary switchboards, sub-feeder panels, fuse panels and starters are to be made tight. Desiccant is to be provided.

Contacts of relays, breakers and switch-breakers are to be coated with neutral vaseline.

Bearings of generators are to be cleaned of old grease and protected with new oil or grease.

Carbon brushes are to be lifted off their commutations.

3.6.2 Electrical insulation of each item is to be kept at a minimum 200,000 Ohms and general insulation is to be not less than 50,000 Ohms. Local electric heating may be necessary to improve the level of insulation, particularly in the generators/alternators and large motors.

A insulation resistance test is to be performed regularly.

3.7 Steering gear

3.7.1 Exposed mechanical parts are to be greased or oil sprayed.

For electrical parts the same preservation measures given in [3.6] are to be taken.

It is recommended that the steering gear should be operated monthly.

3.8 Boilers

3.8.1 Smoke sides of boilers are to be swept, washed clean with basic hot water and hot air dried.

3.8.2 Water and steam sides should preferably be preserved using the dry method, keeping the moisture at the lowest possible level, the ideal level being between 30% and 35%. It is advisable to ensure that no residual water remains to cause rapid corrosion. Drum doors are to be kept closed.

In other cases, it is advisable to keep the boilers, superheaters and economisers filled with water having a pH around 10,5. Hydrazine hydrate treatment of the water is preferable to reduce risks of corrosion caused by dissolved oxygen. The water is to be regularly analysed.

3.8.3 Air heaters are to be cleaned and kept dry.

Uptake, shell and fan outlets are to be cleaned and kept closed with watertight hoods.

Burners are to be dismantled, and atomisers greased.

Desiccant is to be provided in furnaces where deemed necessary.

Expansion arrangements (sliding feet) are to be suitably greased.

The internal condition of boilers is to be checked every three months.

3.8.4 Boilers may also be preserved sealed with inert gas (nitrogen), provided that cocks and valves are tight and the installation allows an internal pressure of at least 0,05 bar to be maintained to prevent air penetration. Regular checks of the overpressure are to be carried out and results recorded in the log-book.

3.9 Automated installation

3.9.1 Recommendations for electronic components are the same as those given for electrical installations.

For pneumatic parts the manufacturers' recommendations are to be followed and the system is to be checked regularly.

Pressure, temperature or level sensors are generally not affected by damage when not used. However, when available, the manufacturers' recommendations are to be followed.

4 Lay-up site and mooring arrangements

4.1 General

4.1.1 The choice and suitability of the lay-up site, as well as the type of mooring conditions, the mooring arrangements and their efficiency during the lay-up period remain the responsibility of the Owner.

However, at the Owner's request, the mooring arrangement may be reviewed by the Society.

4.2 Recommendations for the lay-up site

4.2.1 The following recommendations are to be considered by Owners regarding the choice and suitability of the lay-up site.

The site should be:

- sheltered from open sea, strong currents and waves
- not exposed to whirling winds or turbulent tidal waves
- not exposed to moving ice
- clear of corrosive waste waters
- provided with adequate ship/shore communications.

4.3 Recommendations for the mooring arrangements

4.3.1 The following recommendations are to be considered by Owners with respect to the mooring arrangements:

- ground holding should be adequate
- vessels laid-up to buoys or anchored should be moored in such a way as to be prevented from swinging with normal wind and tidal changes
- chain cables should not be subject to cross-contact or twisting and stern anchorage should generally be provided
- laid-up ships should be in ballast condition in order to reduce the effects of wind. Due consideration should be given to the still water bending moment. For guidance, normal ballast draft should be roughly between 30% and 50% of the maximum draft.

4.3.2 Ships should normally be moored singly. However, when several ships are moored together, the following provisions are to be made:

- ships are to be moored bow to stern
- ships are to be of approximately the same size
- the number of ships moored together is, in principle, not to exceed six
- breast-lines are to be of similar elasticity
- fenders are to be provided.

4.4 Review of the mooring arrangements

4.4.1 As indicated in [4.1.1], at the Owners' request, the mooring arrangements may be reviewed by the Society.

4.4.2 The proposal for the mooring arrangements is in such case to be submitted by the Owner and is to include the following information.

a) Mooring site:

- geographical area (to be specified on a map)
- characteristics of the sea bottom
- water depth
- preferential angular sectors (effects of wind / tide / current) indicated according to statistical studies
- wave characteristics (amplitude, periods)

b) Geometry of mooring arrangements:

- ship's position and direction
- shore anchorage
- diagram showing mooring equipment (fore and aft)
- angle between chain cables and ship's centreline

c) Characteristics of mooring equipment:

- maximum holding strength of each anchor
- type of mooring lines (chains, cables, sinkers, etc.)
- length of each section
- weight of each section
- mechanical characteristics of each section (breaking load)
- weight of sinkers.

4.4.3 On completion of the installation, the mooring arrangements are to be surveyed by the Society. When the ship is anchored, the underwater installation is to be inspected by a diver whose report is to be presented to the Society.

4.4.4 It is the responsibility of the Owners to ascertain the efficiency of the mooring arrangements during the lay-up period. The mooring arrangements are to be re-examined at regular intervals (at least each year when the ship is anchored) and when abnormal weather conditions occur at the lay-up site.

5 Surveys

5.1 Laying-up survey

5.1.1 At the beginning of the lay-up period a laying-up survey is to be carried out whose scope is to verify that the safety conditions, preservation measures, lay-up site and mooring arrangements are in accordance with the program agreed by the Society.

5.1.2 Upon satisfactory completion of this survey, a memorandum is issued to confirm that the ship has been placed in lay-up, which is subsequently to be kept on board.

5.2 Annual lay-up condition survey

5.2.1 As described in Ch 2, Sec 2, [8], an annual lay-up condition survey is to be performed in lieu of the normal annual class surveys. The purpose of this survey is to ascertain that the lay-up maintenance program implemented is continuously complied with.

5.2.2 It is to be checked that the arrangements made for the lay-up are unchanged and that the maintenance work and tests are carried out in accordance with the maintenance manual and recorded in the lay-up log-book.

5.2.3 Upon satisfactory completion of the survey, the Certificate of Classification is endorsed.

5.3 Re-commissioning survey

5.3.1 Owners are to make the necessary arrangements to remove the temporary lay-up installations provided for preservation measures and the protective materials and coatings (oil, grease, inhibitors, desiccants), before the survey is commenced.

It is the Owners' responsibility to verify that the ship parts that are not covered by class are reactivated in satisfactory operational condition.

5.3.2 The scope of the re-commissioning survey is to include:

- a general examination of the hull, deck fittings, safety systems, machinery installations (including boilers whose survey is not due) and steering gear
- all periodical surveys due at the date of re-commissioning or which became overdue during the lay-up period
- dealing with the conditions of class due at the date of re-commissioning or which became due during the lay-up period.

5.3.3 For the hull the following is to be carried out:

- examination of shell plating above the waterline, deck plating, hatch covers and coamings

- examination of load line items
- overall survey of all cargo tanks/holds
- overall survey of representative ballast tanks when the lay-up period does not exceed two years
- overall survey of all ballast tanks when the lay-up period is two years and over
- function tests of bilge and ballast systems.

5.3.4 For the deck fittings the following is to be carried out:

- examination of the fire main under working pressure
- where possible, examination of deck piping under working pressure
- function tests of class items
- checking inert gas installation under working condition after inspection of water seal and function test of deck non-return valve and pressure/vacuum valves.

5.3.5 For machinery installations the following is to be checked:

- the analysis of lubricating oil of main engines, auxiliary engines, reduction gears, main thrust bearings and sterntube
- the general condition of crankcase, crankshaft, piston rods and connecting rods of diesel engines
- the crankshaft deflections of diesel engines. In addition when engines have been laid-up for more than two years, one piston is to be disconnected and one liner is to be removed for examination. Dismantling is to be extended if deemed necessary
- the condition of blades of turbines through the inspection doors
- the condition of the water side of condensers and heat exchangers
- the condition of expansion arrangements
- the condition of reduction gears through the inspection doors
- the condition after overhauling of pressure relief devices
- the test of bilge level alarms, when fitted.

5.3.6 The main and emergency electrical installations are to be tested. The parallel shedding of main generators and main switchboard safety devices are to be checked. An insulation resistance test of the electrical installation is to be performed.

5.3.7 For the fire prevention, detection and fire-fighting systems, the following is to be examined and/or tested:

- remote control for quick closing of fuel oil valves, stopping of fuel oil pumps and ventilation systems, closing of fire doors and watertight doors
- fire detectors and alarms
- fire-fighting equipment.

5.3.8 The automated installation is to be checked for proper operation.

5.3.9 When classed, the installations for refrigerated cargo are to be examined under working conditions. Where the lay-up period exceeds two years, representative components of the installation are to be dismantled.

5.3.10 For cargo installations on liquefied gas carriers, the following is to be carried out:

- inspection of the primary barrier in tanks
- for membrane tanks, a global gas test of tanks whose results are to be compared with those obtained at ship's delivery
- testing of gas piping at working pressure using inert gas.

A Surveyor of the Society is to attend the first cooling down and loading of the ship.

5.3.11 For other specific classed installations, the Owners are to submit a survey program to the Society.

5.3.12 On completion of the above surveys, sea trials are to be performed in the presence of a Surveyor of the Society.

The sea trials are to include:

- verification of the satisfactory performance of the deck installations, main propulsion system and essential auxiliaries, including a test of the safety devices
- an anchoring test
- complete tests of steering gear
- full head and full astern tests
- tests of automated machinery systems, where applicable.

5.3.13 Upon satisfactory completion of the surveys, a memoranda is issued to confirm the carrying out of all relevant surveys and the recommissioning of the ship.

Part A
Classification and Surveys

Chapter 4

**SCOPE OF SURVEYS IN RESPECT OF
THE DIFFERENT SERVICES OF SHIPS**

SECTION 1	GENERAL
SECTION 2	SINGLE SKIN AND DOUBLE SKIN BULK CARRIERS
SECTION 3	OIL TANKERS AND COMBINATION CARRIERS
SECTION 4	CHEMICAL TANKERS
SECTION 5	LIQUEFIED GAS CARRIERS
SECTION 6	RO-RO CARGO SHIPS, PCT CARRIERS, PASSENGER SHIPS, RO-RO PASSENGER SHIPS
SECTION 7	GENERAL CARGO SHIPS
SECTION 8	OTHER SERVICE NOTATIONS
SECTION 9	SHIPS USING LOW FLASHPOINT LIQUID OR GAS FUELS
APPENDIX 1	OIL TANKER LONGITUDINAL STRENGTH ASSESSMENT

SECTION 1 GENERAL

1 General

1.1

1.1.1 The purpose of this Chapter is to give details on the scope of surveys of certain ships which, due to the service notation and/or the additional service feature assigned, and related equipment, need specific requirements to be verified for the maintenance of their class.

1.1.2 These specific requirements either are additional to or supersede those stipulated in Part A, Chapter 3, which gives general requirements for surveys applicable to all types of ships: this is indicated in each Section of this Chapter. These surveys are to be carried out at intervals as described in Ch 2, Sec 2, concurrently with the surveys of the same type, i.e. annual, intermediate or class renewal surveys, detailed in Part A, Chapter 3.

1.1.3 Owners are reminded that a general examination of the ship having the same scope of an annual survey is to be carried out at the completion of the class renewal survey, see Ch 3, Sec 3, [1.1.7]. Where specific requirements are

given in this Chapter for the class renewal survey, they are additional to the applicable requirements for the annual survey.

2 Service notations and/or additional service features subject to additional surveys

2.1

2.1.1 The specific requirements detailed in this Chapter are linked to the service notation(s) and/or the additional service feature(s) assigned to the ship at the request of the Owner. Where a ship has more than one service notation, the specific requirements linked to each one are applicable, insofar as they are not contradictory (in such case, the most stringent requirement will be applied).

2.1.2 Tab 1 indicates which service notations and/or the additional service features are subject to specific requirements, and in which Section or Article they are specified.

Table 1 : Service notations and/or additional service features for which specific requirements are applicable

Service notation and/or additional service feature assigned	Section or Article applicable in this Chapter	Type of surveys affected by these specific requirements	Remarks
bulk carrier ESP bulk carrier BC-A ESP bulk carrier BC-B ESP bulk carrier BC-C ESP self-unloading bulk carrier ESP ore carrier ESP combination carrier/OBO ESP combination carrier/OOC ESP	Ch 4, Sec 2	annual survey intermediate survey class renewal survey	subject to enhanced survey program
oil tanker ESP combination carrier/OBO ESP combination carrier/OOC ESP	Ch 4, Sec 3	annual survey intermediate survey class renewal survey	subject to enhanced survey program
oil storage service	Ch 4, Sec 8, [7]	hull class renewal survey	subject to enhanced survey program
chemical tanker ESP	Ch 4, Sec 4	annual survey intermediate survey class renewal survey	subject to enhanced survey program
liquefied gas carrier liquefied gas carrier - FSRU liquefied gas carrier - FSU	Ch 4, Sec 5	annual survey intermediate survey class renewal survey	
ro-ro cargo ship PCT carrier passenger ship ro-ro passenger ship	Ch 4, Sec 6	annual survey class renewal survey	survey of shell and inner doors is included

Service notation and/or additional service feature assigned	Section or Article applicable in this Chapter	Type of surveys affected by these specific requirements	Remarks
general cargo ship	Ch 4, Sec 7	annual survey intermediate survey class renewal survey	
container ship or ship equipped for carriage of containers	Ch 4, Sec 8, [2]	annual survey class renewal survey	
livestock carrier	Ch 4, Sec 8, [3]	annual survey class renewal survey	
FLS tanker	Ch 4, Sec 8, [4]	annual survey intermediate survey class renewal survey	
dredger hopper dredger hopper unit split hopper unit split hopper dredger	Ch 4, Sec 8, [5]	annual survey class renewal survey	
tug salvage tug escort tug	Ch 4, Sec 8, [6]	annual survey class renewal survey	
supply	Ch 4, Sec 8, [7]	annual survey intermediate survey class renewal survey	
fire-fighting	Ch 4, Sec 8, [8]	annual survey class renewal survey	
oil recovery	Ch 4, Sec 8, [9]	annual survey class renewal survey	
anchor handling	Ch 4, Sec 8, [10]	annual survey class renewal survey	
cable laying	Ch 4, Sec 8, [11]	annual survey class renewal survey	
lifting	Ch 4, Sec 8, [12]	annual survey class renewal survey	
diving support-integrated diving support-portable	Ch 4, Sec 8, [13]	annual survey class renewal survey	
fishing vessel	Ch 4, Sec 8, [14]	annual survey class renewal survey	
standby rescue	Ch 4, Sec 8, [15]	annual survey class renewal survey	
yacht charter-yacht	Ch 4, Sec 8, [16]	intermediate survey class renewal survey	
semi-submersible cargo ship	Ch 4, Sec 8, [17]	annual survey intermediate survey class renewal survey	
diving system-integrated diving system-portable hyperbaric reception facility	Ch 4, Sec 8, [18]	annual survey intermediate survey class renewal survey	
LNGfuel CNGfuel LPGfuel methanolfuel ammoniafuel LFPfuel fuelcell	Ch 4, Sec 9	annual survey intermediate survey class renewal survey	

SECTION 2

SINGLE SKIN AND DOUBLE SKIN BULK CARRIERS

1 General

1.1 Application

1.1.1 The requirements of this Section apply to all self-propelled ships which have been assigned one of the following service notations:

- **bulk carrier ESP** (whether of single or double skin construction)
- **bulk carrier BC-A ESP** (whether of single or double skin construction)
- **bulk carrier BC-B ESP** (whether of single or double skin construction)
- **bulk carrier BC-C ESP** (whether of single or double skin construction)
- **self-unloading bulk carrier ESP**
- **ore carrier ESP**
- **combination carrier/OBO ESP**
- **combination carrier/OOC ESP**

Note 1: A bulk carrier is a ship which is constructed generally with single deck, double bottom, topside tanks and hopper side tanks in cargo spaces, and is intended primarily to carry dry cargo in bulk. Combination carriers are included. Ore carriers and combination carriers are not covered by the Common Structural Rules.

Note 2: A double skin bulk carrier is a ship which is constructed generally with single deck, double bottom, topside tanks and hopper side tanks in cargo spaces, and is intended primarily to carry dry cargo in bulk, including such types as ore carriers and combination carriers, in which all cargo holds are bounded by a double-side skin (regardless of the width of the wing space). Ore carriers and combination carriers are not covered by the Common Structural Rules.

Note 3: For bulk carriers with hybrid cargo hold arrangements, e.g. with some cargo holds of single side skin and others of double side skin, the requirements of single side skin bulk carriers are to apply to cargo holds of single side skin and the requirements of double skin bulk carriers are to apply to cargo holds of double side skin and associated wing spaces.

Note 4: For combination carriers with longitudinal bulkheads, additional requirements are specified in Ch 4, Sec 3, as applicable.

1.1.2 The requirements apply to the surveys of the hull structure and piping systems in way of cargo holds, cofferdams, pipe tunnels, void spaces, fuel oil tanks within the cargo length area and all ballast tanks. They are additional to the requirements applicable to the remainder of the ship, given in Part A, Chapter 3 according to the relevant surveys.

1.1.3 The requirements contain the minimum extent of examination, thickness measurements and tank testing. When substantial corrosion, as defined in Ch 2, Sec 2, [2.2.7], and/or structural defects are found, the survey is to be extended and is to include additional close-up surveys when necessary.

1.1.4 In any kind of survey, i.e. class renewal, intermediate, annual or other surveys having the same scope, thickness measurements, when required by Tab 11, of structures in areas where close-up surveys are required are to be carried out simultaneously with close-up surveys.

1.1.5 In all cases the extent of thickness measurements is to be sufficient as to represent the actual average condition.

1.1.6 When, in any survey, thickness measurements are required:

- the procedure detailed in Ch 2, Sec 2, [2.3] is to be applied
- the thickness measurement firm is to be part of the survey planning meeting to be held prior to commencing the survey.

1.1.7 Special consideration may be given to the extent of close-up surveys and/or thickness measurements in cargo holds as required below for class renewal, intermediate or annual surveys, when all internal and external surfaces of hatch coamings and hatch covers, and all internal surfaces of the cargo holds, excluding the flat tank top areas and the hopper tank sloped plating approximately 300 mm below the side shell frame end brackets, have protective coating in good condition.

The above special consideration may also be given to existing bulk carriers, where Owners elect to coat or recoat cargo holds, in accordance with the Manufacturers' recommendations. However, prior to re-coating the cargo holds, scantlings are to be assessed in the presence of a Surveyor of the Society.

Note 1: Special consideration (or specially considered) as used in this Section is intended to mean as a minimum, that sufficient close-up inspection and thickness measurements are taken to confirm the actual average condition of the structure under the coating.

1.1.8 Ships which are required to comply with Ch 6, Sec 2, [1.3] are subject to the additional thickness measurements contained in Ch 6, Sec 2, [1.3.4] and Ch 6, Sec 2, [1.3.5] with respect to the vertically corrugated transverse watertight bulkhead between cargo holds Nos. 1 and 2 for purposes of determining compliance with Ch 6, Sec 2, [1.3] prior to the relevant compliance deadline stipulated in Ch 6, Sec 2, [1.2.1] and at subsequent intermediate surveys (for ships over 10 years of age) and class renewal surveys for purposes of verifying continuing compliance with Ch 6, Sec 2, [1.3].

1.1.9 Ships which are required to comply with Ch 6, Sec 2, [5] are subject to the additional thickness measurements contained in Ch 6, Sec 2, [5.3] with respect to the side shell frames and brackets for the purposes of determining compliance with Ch 6, Sec 2, [5] prior to the relevant compliance deadline stipulated in Ch 6, Sec 2, [5.2] and at subsequent intermediate and class renewal surveys for purposes of verifying continuing compliance with Ch 6, Sec 2, [5].

1.2 Documentation on board

1.2.1 The Owner is to obtain, supply and maintain documentation on board as specified in [1.2.2] and [1.2.3], which is to be readily available for examination by the Surveyor.

The documentation is to be kept on board for the lifetime of the ship.

For bulk carriers subject to SOLAS Chapter II-1 Part A-1 Regulation 3-10, the Owner is to arrange the updating of the Ship Construction File (SCF) throughout the ship's life whenever a modification of the documentation included in the SCF has taken place. Documented procedures for updating the SCF are to be included within the Safety Management System.

1.2.2 A survey report file is to be a part of the documentation on board consisting of:

- reports of structural surveys
- hull condition evaluation report (summarising the results of class renewal surveys)
- thickness measurement reports.

The survey report file is also to be available in the Owner's management office.

1.2.3 The following additional supporting documentation is to be available on board:

- survey programme as required by [4.1.1] until such time as the class renewal survey or intermediate survey, as applicable, has been completed
- main structural plans of cargo holds and ballast tanks (for CSR ships, these plans are to include, for each structural element, both the as-built and the renewal thicknesses. Any thickness for voluntary addition is also to be clearly indicated on the plans. The midship section plan to be supplied on board the ship is to include the minimum allowable hull girder sectional properties for hold transverse section in all cargo holds)
- previous repair history
- cargo and ballast history
- extent of use of inert gas plant and tank cleaning procedures
- ship's personnel reports on:
 - structural deterioration/defects in general
 - leakage in bulkheads and piping systems
 - condition of corrosion prevention system, if any
- any other information that may help to identify critical structural areas and/or suspect areas requiring inspection.

1.2.4 For bulk carriers subject to SOLAS Chapter II-1 Part A-1 Regulation 3-10, the Ship Construction File (SCF), limited to the items to be retained onboard, is to be available on board.

1.2.5 Prior to survey, the Surveyor examines the documentation on board and its contents, which are used as a basis for the survey.

1.2.6 For bulk carriers subject to SOLAS Chapter II-1 Part A-1 Regulation 3-10:

- on completion of the survey, the surveyor is to verify that the update of the Ship Construction File (SCF) has been done whenever a modification of the documentation included in the SCF has taken place
- for the SCF stored on board ship, the Surveyor is to examine the information on board ship. In cases where any major event, including, but not limited to, substantial repair and conversion, or any modification of the ship structures, the Surveyor is also to verify that the updated information is kept on board the ship. If the updating of the SCF onboard is not completed at the time of survey, the Surveyor records it and requires confirmation at the next periodical survey
- for the SCF stored on shore archive, the Surveyor is to examine the list of information included on shore archive. In cases where any major event, including, but not limited to, substantial repair and conversion, or any modification of the ship structures, the Surveyor is also to verify that the updated information is stored on shore archive by examining the list of information included on shore archive or kept on board the ship. In addition, the surveyor is to confirm that the service contract with of the Archive Center is valid. If the updating of the SCF Supplement ashore is not completed at the time of survey, the Surveyor records it and requires confirmation at the next periodical survey.

1.2.7 For bulk carriers subject to SOLAS Chapter II-1 Part A-1 Regulation 3-10, on completion of the survey, the Surveyor is to verify that any addition and/or renewal of materials used for the construction of the hull structure is/are documented within the SCF list of materials.

1.3 Reporting and evaluation of surveys

1.3.1 The data and information on the structural condition of the ship collected during survey are evaluated for acceptability and structural integrity of the ship's cargo area.

1.3.2 For CSR bulk carriers, the ship longitudinal strength is to be evaluated, using thickness of the structural members measured, renewed and reinforced, as appropriate, during the renewal surveys carried out after the ship reached 15 years of age (or during the 3rd renewal survey, if this one is carried out before the ship reaches 15 years), in accordance with the criteria for longitudinal strength of the ship hull girder for CSR bulk carriers specified in NR522 CSR for Bulk Carriers, Chapter 13 or in NR606 CSR for Bulk Carriers and Oil Tankers, Part 1, Chapter 13, as applicable.

1.3.3 The final result of evaluation of the ship longitudinal strength required in [1.3.2], after renewal or reinforcement work of structural members, if carried out as a result of initial evaluation, is to be reported as a part of the hull condition evaluation report.

1.3.4 When a survey is split between different survey stations, a report is to be made for each portion of the survey. A list of items examined and/or tested (pressure testing, thickness measurement etc.) and an indication of whether the item has been credited, are to be made available to the next attending Surveyor(s), prior to continuing or completing the survey.

1.3.5 A hull condition evaluation report (summarising the results of class renewal surveys) is issued by the Society to the Owner, who is to place it on board the ship for reference at future surveys. The hull condition evaluation report is endorsed by the Society.

1.4 Conditions for survey

1.4.1 In order to enable the attending surveyors to carry out the survey, provisions for proper and safe access are to be agreed between the Owner and the Society.

Details of the means of access are to be provided in the survey planning questionnaire.

In cases where the provisions of safety and required access are judged by the attending surveyor(s) not to be adequate, the survey of the spaces involved is not to proceed.

1.5 Access to structures

1.5.1 For overall surveys, means are to be provided to enable the Surveyor to examine the hull structure in a safe and practical way.

1.5.2 For close-up surveys of the hull structure, other than cargo hold shell frames, one or more of the following means for access, acceptable to the Surveyor, is/are to be provided:

- permanent staging and passages through structures
- temporary staging and passages through structures
- hydraulic arm vehicles such as conventional cherry pickers, lifts and movable platforms
- portable ladders
- boats or rafts
- other equivalent means.

1.5.3 For close-up surveys of the cargo hold shell frames of bulk carriers less than 100,000 dwt, one or more of the following means for access, acceptable to the Surveyor, is/are to be provided:

- permanent staging and passages through structures
- temporary staging and passages through structures
- portable ladder restricted to not more than 5 m in length may be accepted for surveys of lower section of a shell frame including bracket
- hydraulic arm vehicles such as conventional cherry pickers, lifts and movable platforms
- boats or rafts provided the structural capacity of the hold is sufficient to withstand static loads at all levels of water
- other equivalent means.

1.5.4 For close-up surveys of the cargo hold shell frames of bulk carriers 100,000 dwt and above, the use of portable ladders is not accepted, and one or more of the following means for access, acceptable to the Surveyor, is/are to be provided:

- a) Annual surveys, intermediate surveys for ships less than ten years of age and class renewal surveys for ships five years of age or less:
 - permanent staging and passages through structures
 - temporary staging and passages through structures
 - hydraulic arm vehicles such as conventional cherry pickers, lifts and movable platforms
 - boats or rafts provided the structural capacity of the hold is sufficient to withstand static loads at all levels of water
 - other equivalent means.
- b) Subsequent intermediate surveys and class renewal surveys:
 - either permanent or temporary staging and passages through structures for close-up survey of at least the upper part of hold frames
 - hydraulic arm vehicles such as conventional cherry pickers for surveys of lower and middle part of shell frames as alternative to staging
 - lifts and movable platforms
 - boats or rafts provided the structural capacity of the hold is sufficient to withstand static loads at all levels of water
 - other equivalent means.
- c) Notwithstanding the above requirements:
 - 1) The use of a portable ladder fitted with a mechanical device to secure the upper end of the ladder is acceptable for the:
 - close-up survey of sufficient extent, minimum 25% of frames, to establish the condition of the lower region of the shell frames including approximately the lower one third length of side frame at side shell and side frame end attachment and the adjacent shell plating in the forward cargo hold at annual survey of cargo holds for single skin bulk carriers between 10 and 15 years
 - close-up survey of sufficient extent, minimum 25% of frames, to establish the condition of the lower region of the shell frames including approximately the lower one third length of side frame at side shell and side frame end attachment and the adjacent shell plating in the forward cargo hold and one other selected cargo hold at annual survey of cargo holds for single skin bulk carriers over 15 years.
 - 2) The use of hydraulic arm vehicles or aerial lifts ("Cherry picker") may be accepted by the attending surveyor for the close-up survey of the upper part of side shell frames or other structures in all cases where the maximum working height is not more than 17 m.

2 Annual survey

2.1 General

2.1.1 The survey is to consist of an examination for the purpose of ensuring, as far as practicable, that the hull and piping are maintained in a satisfactory condition and should take into account the service history, condition and extent of the corrosion prevention system of ballast tanks and areas identified in the survey report file.

2.2 Hatch covers and coamings, weather decks

2.2.1 Confirmation is to be obtained that no unapproved changes have been made to the hatch covers, hatch coamings and their securing and sealing devices since the last survey.

2.2.2 A thorough survey of cargo hatch covers and coamings is only possible by examination in the open as well as closed positions and is to include verification of proper opening and closing operation. As a result, the hatch cover sets within the forward 25% of the ship's length and at least one additional set, such that all sets on the ship are assessed at least once in every five year period, are to be surveyed open, closed and in operation to the full extent on each direction, including:

- a) stowage and securing in open condition
- b) proper fit and efficiency of sealing in closed condition, and
- c) operational testing of hydraulic and power components, wires, chains, and link drives.

The closing of the covers is to include the fastening of all peripheral, and cross joint cleats or other securing devices. Particular attention is to be paid to the condition of the hatch covers in the forward 25% of the ship's length, where sea loads are normally greatest.

2.2.3 If there are indications of difficulty in operating and securing hatch covers, additional sets above those required by [2.2.2], at the discretion of the Surveyor, are to be tested in operation.

2.2.4 Where the cargo hatch securing system does not function properly, repairs are to be carried out under the supervision of the Society.

Where hatch covers or coamings undergo substantial repairs, the strength of securing devices should be upgraded to comply with the requirements laid down in Ch 6, App 1, [6.2], Ch 6, App 1, [6.3] and Ch 6, App 1, [6.4].

2.2.5 For each cargo hatch cover set, the following items are to be surveyed:

- a) cover panels, including side plates, and stiffener attachments that may be accessible in the open position by close-up survey (for corrosion, cracks, deformation)

- b) sealing arrangements of perimeter and cross joints (gaskets for condition and permanent deformation, flexible seals on combination carriers, gasket lips, compression bars, drainage channels and non return valves)
- c) clamping devices, retaining bars, cleating (for wastage, adjustment, and condition of rubber components)
- d) closed cover locating devices (for distortion and attachment)
- e) chain or rope pulleys
- f) guides
- g) guide rails and track wheels
- h) stoppers
- i) wires, chains, tensioners, and gypsies
- j) hydraulic system, electrical safety devices and interlocks, and
- k) end and interpanel hinges, pins and stools where fitted.

2.2.6 At each hatchway, the coamings, with plating stiffeners and brackets, are to be checked for corrosion, cracks and deformation, especially of the coaming tops, including close-up survey.

2.2.7 Where considered necessary, the effectiveness of sealing arrangements may be proved by hose or chalk testing supplemented by dimensional measurements of seal compressing components.

2.2.8 Where portable covers, wooden or steel pontoons are fitted, checking the satisfactory condition, where applicable, of:

- wooden covers and portable beams, carriers or sockets for the portable beam, and their securing devices
- steel pontoons, including close-up survey of hatchcover plating
- tarpaulins
- cleats, battens and wedges
- hatch securing bars and their securing devices
- loading pads/bars and the side plate edge
- guide plates and chocks
- compression bars, drainage channels and drain pipes (if any).

2.2.9 The annual survey is also to include:

- examination of flame screens on vents to all bunker tanks
- examination of bunker and vent piping systems, including ventilators
- confirmation, when appropriate and as far as practicable when examining internal spaces, that the means of access to cargo and other spaces remain in good condition.
- examination of watertight penetrations as far as practicable.

2.3 Cargo holds

2.3.1 The requirements given in Tab 1 for single skin bulk carriers or Tab 2 for double skin bulk carriers are to be complied with.

Table 1 : Annual survey of cargo holds for single skin bulk carriers

Age of ship (in years at time of annual survey)	
10 < age ≤ 15	age > 15
<p>Overall survey of all cargo holds</p> <p>Close-up survey of sufficient extent, minimum 25% of frames, to establish the condition of the lower region of the shell frames including approximately the lower one third length of side frame at side shell and side frame end attachment and the adjacent shell plating in the forward cargo hold. See (1)</p> <p>See (2) and (3)</p> <p>Examination of all piping and penetrations, including overboard piping, in cargo holds</p>	<p>Overall survey of all cargo holds</p> <p>Close-up survey of sufficient extent, minimum 25% of frames, to establish the condition of the lower region of the shell frames including approximately the lower one third length of side frame at side shell and side frame end attachment and the adjacent shell plating in the forward cargo hold and one other selected cargo hold. See (1)</p> <p>See (2) and (3)</p> <p>Examination of all piping and penetrations, including overboard piping, in cargo holds</p>
<p>(1) Where this level of survey reveals the need for remedial measures, the survey is to be extended to include a close-up survey of all of the shell frames and adjacent shell plating of that cargo hold as well as a close-up survey of sufficient extent of all remaining cargo holds.</p> <p>(2) When considered necessary by the Surveyor or where extensive corrosion exists, thickness measurements are to be carried out. If the results of these thickness measurements indicate that substantial corrosion is present, the extent of thickness measurements is to be increased in accordance with Tab 12 to Tab 16. These extended thickness measurements are to be carried out before the annual survey is credited as completed. Suspect areas identified at previous surveys are to be examined. Areas of substantial corrosion identified at previous surveys are to have thickness measurements taken.</p> <p>For ships built under the Common Structural Rules, the annual thickness gauging may be omitted where a protective coating has been applied in accordance with the coating manufacturer's requirements and is maintained in good condition.</p> <p>(3) Where a hard protective coating in cargo holds as provided in [1.1.7] is found in good condition, the extent of close-up survey and thickness measurements may be specially considered.</p>	

Table 2 : Annual survey of cargo holds for double skin bulk carriers

Age of ship (in years at time of annual survey)	
10 < age ≤ 15	age > 15
<p>Overall survey of two selected cargo holds</p> <p>See (1)</p> <p>Examination of all piping and penetrations, including overboard piping, in cargo holds</p>	<p>Overall survey of all cargo holds</p> <p>See (1)</p> <p>Examination of all piping and penetrations, including overboard piping, in cargo holds</p>
<p>(1) When considered necessary by the Surveyor, or where extensive corrosion exists, thickness measurements are to be carried out. If the results of these thickness measurements indicate that substantial corrosion is found, the extent of thickness measurements is to be increased in accordance with Tab 17 to Tab 20. These extended thickness measurements are to be carried out before the survey is credited as complete. Suspect areas identified at previous surveys are to be examined. Areas of substantial corrosion identified at previous surveys are to have thickness measurements taken.</p> <p>For ships built under the Common Structural Rules, the annual thickness gauging may be omitted where a protective coating has been applied in accordance with the coating manufacturer's requirements and is maintained in good condition.</p>	

2.4 Ballast tanks

2.4.1 Ballast tanks are to be internally examined when required as a consequence of the results of the class renewal survey or the intermediate survey; see [4.3.6] and footnote (3) of Tab 4 for single skin bulk carriers or footnote (3) of Tab 6 for double skin bulk carriers.

2.4.2 When considered necessary by the Surveyor or where extensive corrosion exists, thickness measurements are to be carried out. If the results of these thickness measurements indicate that substantial corrosion is found, the extent of thickness measurements is to be increased in accordance with Tab 12 to Tab 16 for single skin bulk carriers

or Tab 17 to Tab 20 for double skin bulk carriers. These extended thickness measurements are to be carried out before the survey is credited as completed.

Suspect areas identified at previous surveys are to be examined.

Areas of substantial corrosion identified at previous surveys are to have thickness measurements taken.

For ships built under the Common Structural Rules, the annual thickness gauging may be omitted where a protective coating has been applied in accordance with the coating manufacturer's requirements and is maintained in good condition.

3 Intermediate survey

3.1 Ships 10 years of age or less

3.1.1 The requirements for survey of cargo holds given in Tab 3 for single skin bulk carriers or Tab 5 for double skin bulk carriers are to be complied with.

3.1.2 The requirements for survey of salt water ballast tanks given in Tab 4 for single skin bulk carriers or Tab 6 for double skin bulk carriers are to be complied with.

3.2 Ships between 10 and 15 years of age

3.2.1 The scope of intermediate survey of ships between 10 and 15 years of age is the scope of the preceding class renewal survey of hull, as detailed in Article [4] with bottom survey in dry condition or bottom in water survey as applicable. However, internal examination of fuel oil tanks and pressure testing of all tanks are not required unless deemed necessary by the attending Surveyor.

3.3 Ships over 15 years of age

3.3.1 The scope of intermediate survey of ships over 15 years of age is the scope of the preceding class renewal survey of hull, as detailed in [4] with bottom survey in dry condition. However, internal examination of fuel oil tanks and pressure testing of all tanks are not required unless deemed necessary by the attending Surveyor.

The overall and close-up surveys and thickness measurements, as applicable, of the lower portions of the cargo holds and water ballast tanks are to be carried out during the bottom survey in accordance with the applicable requirements for intermediate surveys, if not already performed.

Lower portions of the cargo holds and ballast tanks are considered to be the parts below light ballast water line.

**Table 3 : Intermediate survey of cargo holds for single skin bulk carriers
Ships 10 years of age or less at time of the intermediate survey**

Overall survey of all cargo holds. See (1)
Close-up survey in the forward cargo hold and one other selected cargo hold, to establish the condition of: <ul style="list-style-type: none"> at least 25% of the side shell frames including their upper and lower end attachments, and adjacent shell plating the transverse bulkheads Examination of suspect areas identified at previous surveys See (1)
Thickness measurements to an extent sufficient to determine both general and local corrosion levels in areas subject to close-up survey. The minimum requirements for thickness measurements are areas found to be suspect areas at the previous surveys. See (2), (3) and (4).
(1) Where considered necessary by the Surveyor as a result of the overall and close-up surveys, the survey is to be extended to include a close-up survey of all the shell frames and adjacent shell plating of that cargo hold as well as a close-up survey of sufficient extent of all remaining cargo holds. (2) Where the hard protective coating in cargo holds as provided in [1.1.7] is found to be in good condition, the extent of close-up survey and thickness measurements may be specially considered. (3) The extent of thickness measurements may be specially considered provided the Surveyor is satisfied by the close-up survey, that there is no structural diminution and the hard protective coatings are found to be in a good condition. (4) Where substantial corrosion is found, the extent of thickness measurements is to be increased in accordance with Tab 12 to Tab 16. These extended thickness measurements are to be carried out before the survey is credited as completed. Suspect areas identified at previous surveys are to be examined. Areas of substantial corrosion identified at previous surveys are to have thickness measurements taken. For ships built under the Common Structural Rules, the identified substantial corrosion areas may be: <ul style="list-style-type: none"> protected by coating, applied in accordance with the coating manufacturer's requirements and examined at annual intervals to confirm the coating in way is still in good condition, or, alternatively required to be measured at annual intervals. Note 1: For existing bulk carriers, where Owners may elect to coat or recoat cargo holds as noted above, consideration may be given to the extent of the close-up and thickness measurement surveys. Prior to the coating of cargo holds of existing ships, scantlings are to be ascertained in the presence of a Surveyor.

**Table 4 : Intermediate survey of salt water ballast spaces for single skin bulk carriers
Ships 10 years of age or less at time of the intermediate survey**

Overall survey of representative water ballast spaces selected by the Surveyor. The selection is to include fore and aft peak tanks and a number of other tanks, taking into account the total number and type of ballast tanks. See (1), (2) and (3)
Overall and close-up survey of suspect areas identified at previous surveys
The minimum requirements for thickness measurements are areas found to be suspect areas at previous surveys. See (4) and (5)
<p>(1) If such overall survey reveals no visible structural defects, the examination may be limited to verification that the corrosion prevention system remains efficient.</p> <p>(2) Where poor coating condition, corrosion or other defects are found in water ballast tanks or where a hard protective coating was not applied from the time of construction, the examination is to be extended to other ballast tanks of the same type.</p> <p>(3) For ballast tanks other than double bottom tanks, where a hard protective coating is found in poor condition, and it is not renewed, or where soft or semi-hard coating has been applied or where a hard protective coating was not applied from the time of construction, the tanks in question are to be internally examined and thickness measurement carried out as considered necessary at annual surveys.</p> <p>When such breakdown of hard protective coating is found in ballast double bottom tanks or where a soft or semi-hard coating has been applied or where a hard protective coating has not been applied, the tanks in question may be internally examined at annual surveys. When considered necessary by the Surveyor, or where extensive corrosion exists, thickness measurements are to be carried out.</p> <p>(4) The extent of thickness measurements may be specially considered provided the Surveyor is satisfied by the close-up survey, that there is no structural diminution and the hard protective coatings are found to be in a good condition.</p> <p>(5) Where substantial corrosion is found, the extent of thickness measurements is to be increased in accordance with the requirements of Tab 12 to Tab 16. These extended thickness measurements are to be carried out before the survey is credited as completed. Suspect areas identified at previous surveys are to be examined. Areas of substantial corrosion identified at previous surveys are to have thickness measurements taken.</p>

**Table 5 : Intermediate survey of cargo holds for double skin bulk carriers
Ships 10 years of age or less at time of the intermediate survey**

Overall survey of all cargo holds. See (1)
Thickness measurements to an extent sufficient to determine both general and local corrosion levels at areas subject to close-up survey. See (2), (3) and (4)
<p>(1) Where considered necessary by the Surveyor as a result of the overall survey, the survey is to be extended to include a close-up survey of those areas of structure in the cargo holds selected by the Surveyor.</p> <p>(2) The extent of thickness measurements may be specially considered provided the Surveyor is satisfied by the close-up survey that there is no structural diminution and the hard protective coatings are found to be in a good condition.</p> <p>(3) Where substantial corrosion is found, the extent of thickness measurements is to be increased in accordance with Tab 17 to Tab 20. These extended thickness measurements are to be carried out before the survey is credited as completed. Suspect areas identified at previous surveys are to be examined. Areas of substantial corrosion identified at previous surveys are to have thickness measurements taken.</p> <p>For ships built under the Common Structural Rules, the identified substantial corrosion areas may be:</p> <ul style="list-style-type: none"> • protected by coating, applied in accordance with the coating manufacturer's requirements and examined at annual intervals to confirm the coating in way is still in good condition, or, alternatively • required to be measured at annual intervals. <p>(4) Where a hard protective coating in cargo holds as provided in [1.1.7] is found in good condition, the extent of close-up survey and thickness measurements may be specially considered.</p> <p>Note 1: For existing bulk carriers, where Owners may elect to coat or recoat cargo holds as noted above, consideration may be given to the extent of the close-up and thickness measurement surveys. Prior to the coating of cargo holds of existing ships, scantlings are to be ascertained in the presence of a Surveyor.</p>

**Table 6 : Intermediate survey of ballast tanks for double skin bulk carriers
Ships 10 years of age or less at time of the intermediate survey**

Overall survey of representative water ballast tanks selected by the Surveyor. The selection is to include fore and aft peak tanks and a number of other tanks, taking into account the total number and type of ballast tanks. See (1), (2) and (3)
Overall and close-up survey of suspect areas identified at previous surveys.
Thickness measurements to an extent sufficient to determine both general and local corrosion levels at areas subject to close-up survey. See (4) and (5)
<p>(1) If such overall survey reveals no visible structural defects, the examination may be limited to verification that the corrosion prevention system remains efficient.</p> <p>(2) Where poor coating condition, corrosion or other defects are found in water ballast tanks or where a hard protective coating was not applied from the time of construction, the examination is to be extended to other ballast tanks of the same type.</p> <p>(3) In ballast tanks other than double bottom tanks, where a hard protective coating is found in poor condition and it is not renewed, or where soft or semi-hard coating has been applied, or where a hard protective coating was not applied from the time of construction, the tanks in question are to be examined and thickness measurements carried out as considered necessary at annual surveys. When such breakdown of hard protective coating is found in ballast double bottom tanks, or where a soft or semi-hard coating has been applied, or where a hard protective coating has not been applied, the tanks in question may be examined at annual surveys. When considered necessary by the Surveyor, or where extensive corrosion exists, thickness measurements are to be carried out.</p> <p>(4) The extent of thickness measurements may be specially considered provided the Surveyor is satisfied by the close-up survey that there is no structural diminution and the hard protective coatings are found to be in a good condition.</p> <p>(5) Where substantial corrosion is found, the extent of thickness measurements is to be increased in accordance with Tab 17 to Tab 20. These extended thickness measurements are to be carried out before the survey is credited as completed. Suspect areas identified at previous surveys are to be examined. Areas of substantial corrosion identified at previous surveys are to have thickness measurements taken.</p>

4 Class renewal survey

4.1 Survey programme and preparation for survey

4.1.1 The Owner in cooperation with the Society is to work out a specific Survey Programme prior to the commencement of any part of:

- the class renewal survey
- the intermediate survey for bulk carriers over 10 years of age.

The survey programme is to be in a written format. The survey is not to commence until the Survey Programme has been agreed.

Prior to the development of the Survey Programme, the survey planning questionnaire is to be completed by the Owner and forwarded to the Society.

The survey programme at intermediate survey may consist of the survey programme at the previous class renewal survey supplemented by the hull condition evaluation report of that class renewal survey and later relevant survey reports.

The survey programme is to be worked out taking into account any amendments to the survey requirements after the last class renewal survey carried out.

4.1.2 In developing the survey programme, the following documentation is to be collected and consulted with a view to selecting holds, tanks, areas and structural elements to be examined:

- a) survey status and basic ship information
- b) documentation on board, as described in [1.2.2] and [1.2.3]
- c) main structural plans (scantling drawings), including information on use of high tensile steels (HTS)

- d) relevant previous survey and inspection reports from both the Society and the Owner
- e) information regarding the use of ship's holds and tanks, typical cargoes and other relevant data
- f) information regarding corrosion prevention level on the newbuilding
- g) information regarding the relevant maintenance level during operation.

4.1.3 The submitted Survey Programme is to account for and comply, as a minimum, with the requirements of [4.5], [4.6] and [4.7], for close-up survey, thickness measurement and tank testing, respectively, and is to include relevant information including at least:

- a) basic ship information and particulars
- b) main structural plans (scantling drawings), including information regarding use of high tensile steels (HTS)
- c) plan of holds and tanks
- d) list of holds and tanks with information on use, protection and condition of coating
- e) conditions for survey (e.g. information regarding hold and tank cleaning, gas freeing, ventilation, lighting, etc.)
- f) provisions and methods for access to structures
- g) equipment for surveys
- h) nomination of holds and tanks and areas for close-up surveys according to [4.5]
- i) nomination of sections for thickness measurements according to [4.6]
- j) nomination of tanks for tank testing according to [4.7]
- k) damage experience related to the ship in question.

4.1.4 The Society is to advise the Owner of the maximum acceptable structural corrosion diminution levels applicable to the ship.

4.2 Survey planning meeting

4.2.1 The establishment of proper preparation and the close co-operation between the attending surveyor(s) and the owner's representatives onboard prior to and during the survey are an essential part in the safe and efficient conduct of the survey. During the survey on board, safety meetings are to be held regularly.

4.2.2 Prior to commencement of any part of the renewal and intermediate survey, a survey planning meeting is to be held between the attending surveyor(s), the owner's representative in attendance, the thickness measurement firm representative, where involved, and the master of the ship or an appropriately qualified representative appointed by the master or Company for the purpose to ascertain that all the arrangements envisaged in the survey programme are in place, so as to ensure the safe and efficient conduct of the survey work to be carried out. See also Ch 2, Sec 2, [2.3.2].

4.2.3 The following is an indicative list of items that are to be addressed in the meeting:

- a) schedule of the ship (i.e. the voyage, docking and undocking manoeuvres, periods alongside, cargo and ballast operations, etc.)
- b) provisions and arrangements for thickness measurements (i.e. access, cleaning/de-scaling, illumination, ventilation, personal safety)
- c) extent of the thickness measurements
- d) acceptance criteria (refer to the list of minimum thicknesses)
- e) extent of close-up survey and thickness measurements considering the coating condition and suspect areas/areas of substantial corrosion
- f) execution of thickness measurements
- g) taking representative readings in general and where uneven corrosion/pitting is found
- h) mapping of areas of substantial corrosion, and
- i) communication between attending surveyor(s), the thickness measurement firm operator(s) and owner representative(s) concerning findings.

4.3 Scope of survey

4.3.1 In addition to the requirements of annual surveys, the class renewal survey is to include examination, tests and checks of sufficient extent to ensure that the hull and related piping, as required in [4.3.3] is in satisfactory condition for the new period of class to be assigned, subject to proper maintenance and operation and to periodical surveys being carried out at the due dates.

4.3.2 All cargo holds, ballast tanks, including double bottom tanks, double side tanks as applicable, pipe tunnels, cofferdams and void spaces bounding cargo holds, decks and outer hull are to be examined, and this examination is to be supplemented by thickness measurement and testing required in

[4.6] and [4.7], to ensure that the structural integrity remains effective. The aim of the examination is to discover substantial corrosion, significant deformation, fractures, damages or other structural deterioration that may be present.

4.3.3 All piping systems within the above spaces are to be examined and operationally tested to working pressure to attending Surveyor's satisfaction to ensure that tightness and condition remain satisfactory.

4.3.4 The survey extent of ballast tanks converted to void spaces will be specially considered by the Society in relation to the requirements for ballast tanks.

4.3.5 As indicated in Ch 3, Sec 3, [2.1.1], a bottom survey in dry condition is to be a part of the class renewal survey. The overall and close-up surveys and thickness measurements, as applicable, of the lower portions of the cargo holds and ballast tanks are to be carried out during this bottom survey in accordance with the applicable requirements for class renewal surveys, if not already performed.

Note 1: Lower portions of the cargo holds and ballast tanks are considered to be the parts below light ballast water line.

4.3.6 Where provided, the condition of the corrosion prevention system of ballast tanks is to be examined.

For ballast tanks, excluding double bottom tanks, where a hard protective coating is found in poor condition, and it is not renewed, where soft or semi-hard coating has been applied, or where a hard protective coating has not been applied from the time of construction, the tanks in question are to be examined at annual surveys. Thickness measurement are to be carried out as deemed necessary by the Surveyor.

When such a breakdown of hard protective coating is found in water ballast double bottom tanks and it is not renewed, where a soft or semi-hard coating has been applied, or where a hard protective coating has not been applied from the time of construction, the tanks in question may be examined at annual surveys. When considered necessary by the Surveyor, or where extensive corrosion exists, thickness measurement are to be carried out.

4.3.7 Where hard protective coating in cargo holds, as provided in [1.1.7], is found in good condition, the extent of close-up surveys and thickness measurements may be specially considered.

4.4 Hatch covers and coamings

4.4.1 A survey of the items listed in [2.2] is to be carried out, in addition to all hatch covers and coamings.

4.4.2 Checking of the satisfactory operation of all mechanically operated hatch covers is to be made, including:

- stowage and securing in open condition
- proper fit and efficiency of sealing in closed condition
- operational testing of hydraulic and power components, wires, chains, and link drives.

4.4.3 Checking the effectiveness of sealing arrangements of all hatch covers by hose testing or equivalent.

4.4.4 The close-up survey and thickness measurements in accordance with the requirements given in Tab 8, Tab 9, Tab 10 and Tab 11, respectively, are to be carried out.

Subject to cargo hold hatch covers of approved design which structurally have no access to the internals, close-up survey/thickness measurement is to be done of the accessible parts of hatch cover structures.

4.5 Overall and close-up surveys

4.5.1 An overall survey of all tanks and spaces is to be carried out at each class renewal survey. Fuel oil tanks in the cargo length area are to be surveyed as per Tab 7.

Table 7 : Requirements for internal examination of fuel oil tanks in the cargo length area

Age of ship (in years at time of class renewal survey)			
Class renewal survey No.1 age ≤ 5	Class renewal survey No.2 5 < age ≤ 10	Class renewal survey No.3 10 < age ≤ 15	Class renewal survey No.4 & subsequent age > 15
none	one	two (1)	half (min. two) (1)
<p>(1) One deep tank for fuel oil in the cargo area is to be included, if fitted. Note 1: Tanks considered are of the integral (structural) type. Note 2: If a selection of tanks is accepted to be examined, then different tanks are to be examined at each class renewal survey, on a rotational basis. Note 3: Peak tanks (all uses) are subject to internal examination at each class renewal survey.</p>			

4.5.2 The minimum requirements for close-up surveys are given in Tab 8 for single skin bulk carriers, in Tab 9 for double skin bulk carriers excluding ore carriers and in Tab 10 for ore carriers.

4.5.3 The Surveyor may extend the close-up survey as deemed necessary taking into account the maintenance of the spaces under survey, the condition of the corrosion prevention system and where spaces have structural arrangements or details which have suffered defects in similar spaces or on similar ships according to available information.

4.5.4 For areas in spaces where hard protective coatings are found to be in a good condition, the extent of close-up surveys according to Tab 8 for single skin bulk carriers, Tab 9 for double skin bulk carriers excluding ore carriers and Tab 10 for ore carriers, may be specially considered. Refer also to [4.3.7].

4.6 Thickness measurements

4.6.1 The minimum requirements for thickness measurements at class renewal survey are given in Tab 11.

Note 1: Attention is drawn to specific thickness measurements to be carried out on the bulkhead between the two foremost cargo holds for ships which are to comply with retroactive requirements

as detailed in Ch 6, Sec 2, [1.3] and to additional thickness measurements applicable to the side shell frames and brackets on ships subject to compliance with Ch 6, Sec 2, [5].

4.6.2 Provisions for extended measurements for areas with substantial corrosion are given in Tab 12 to Tab 20 and as may be additionally specified in the survey programme as required by [4.1]. These extended thickness measurements are to be carried out before the survey is credited as completed. Suspect areas identified at previous surveys are to be examined. Areas of substantial corrosion identified at previous surveys are to have thickness measurements taken.

Note 1: For ships built under the Common Structural Rules, the identified substantial corrosion areas may be:

- protected by coating, applied in accordance with the coating manufacturer's requirements and examined at annual intervals to confirm the coating in way is still in good condition, or, alternatively
- required to be measured at annual intervals.

4.6.3 The Surveyor may further extend the thickness measurements as deemed necessary.

4.6.4 When pitting is found on bottom plating and its intensity is 20% or more, thickness measurements are to be extended in order to determine the actual plate thickness out of the pits and the depth of the pits. Where the wastage is in the substantial corrosion range or the average depth of pitting is 1/3 or more of the actual plate thickness, the pitted plate is to be considered as a substantially corroded area.

4.6.5 For areas in tanks where hard protective coatings are found to be in a good condition (see Ch 2, Sec 2, [2.2.14]), the extent of thickness measurements according to Tab 11 may be specially considered by the Society. Refer also to [4.3.7].

4.6.6 For single skin bulk carriers, representative thickness measurements to determine both general and local levels of corrosion in the shell frames and their end attachments in all cargo holds and water ballast tanks is to be carried out. For double skin bulk carriers, representative thickness measurement to determine both general and local levels of corrosion in the transverse web frames in all water ballast tanks is to be carried out.

Thickness measurements is also to be carried out to determine the corrosion levels on the transverse bulkhead plating. The extent of thickness measurements may be specially considered provided the Surveyor is satisfied by the close-up survey, that there is no structural diminution, and the hard protective coating where applied remains efficient.

4.7 Tank testing

4.7.1 All boundaries of water ballast tanks, deep tanks and cargo holds used for water ballast within the cargo length area are to be pressure tested. For fuel oil tanks, only representative tanks are to be pressure tested.

4.7.2 The Surveyor may extend the tank testing as deemed necessary.

Table 8 : Requirements for close-up survey at class renewal survey of single skin bulk carriers

Age of ship (in years at time of class renewal survey)			
Class renewal survey No.1 age ≤ 5	Class renewal survey No.2 5 < age ≤ 10	Class renewal survey No.3 10 < age ≤ 15	Class renewal survey No.4 and subsequent age > 15
25% of shell frames in the forward cargo hold at representative positions ① Selected shell frames in all remaining cargo holds ①	All shell frames in the forward cargo hold and 25% of shell frames in each of the remaining cargo holds, including upper and lower end attachments and adjacent shell plating ① For bulk carriers 100,000 dwt and above, all shell frames in the forward cargo hold and 50% of shell frames in each of the remaining cargo holds, including upper and lower end attachments and adjacent shell plating ①	All shell frames in the forward and one other selected cargo hold and 50% of shell frames in each of the remaining cargo holds including upper and lower end attachments and adjacent shell plating ①	All shell frames in all cargo holds including upper and lower end attachments and adjacent shell plating ①
One transverse web with associated plating and longitudinals in two representative water ballast tanks of each type (i.e. topside or hopper side tank) ②	One transverse web with associated plating and longitudinals in each water ballast tank ② Forward and aft transverse bulkheads in one ballast tank, including stiffening system ②	All transverse webs with associated plating and longitudinals in each water ballast tank ② All transverse bulkheads in ballast tanks, including stiffening system ②	Areas ② to ⑤ as for class renewal survey for ships between 10 and 15 years of age
Two selected cargo hold transverse bulkheads ③	All cargo hold transverse bulkheads ③	All cargo hold transverse bulkheads ③	
All cargo hold hatch covers and coamings ④	All cargo hold hatch covers and coamings ④	All cargo hold hatch covers and coamings ④	
	All deck plating and underdeck structure inside line of hatch openings between all cargo hold hatches ⑤	All deck plating and underdeck structure inside line of hatch openings between all cargo hold hatches ⑤	
<p>Note 1: See Fig 1 for areas ①, ②, ③, ④ and ⑤. See also Ch 6, Sec 2, Fig 3 for zones of side shell frames for ships subject to compliance with Ch 6, Sec 2, [5].</p> <p>① Cargo hold transverse frames.</p> <p>② Transverse web frame or transverse watertight bulkhead in water ballast tanks.</p> <p>③ Cargo hold transverse bulkhead plating, stiffeners and girders, including internal structure of upper and lower stools, where fitted.</p> <p>④ Cargo hold hatch covers and coamings (plating and stiffeners). Subject to cargo hold hatch covers of approved design which structurally have no access to the internals, close-up survey/thickness measurement is to be done of the accessible parts of hatch cover structures.</p> <p>⑤ Deck plating and under deck structure inside line of hatch openings between cargo hold hatches.</p> <p>Note 2: Close-up survey of transverse bulkheads to be carried out at four levels (see Fig 2):</p> <ul style="list-style-type: none"> - immediately above the inner bottom and immediately above the line of gussets (if fitted) and shedders for bulkheads without lower stool - immediately above and below the lower stool shelf plate (for bulkheads fitted with lower stools), and immediately above the line of the shedder plates - about mid-height of the bulkhead - immediately below the upper deck plating and immediately adjacent to the upper wing tank, and immediately below the upper stool shelf plate for bulkheads fitted with upper stools, or immediately below the top side tanks. 			

Figure 1 : Close-up surveys and thickness measurement areas for single skin bulk carriers

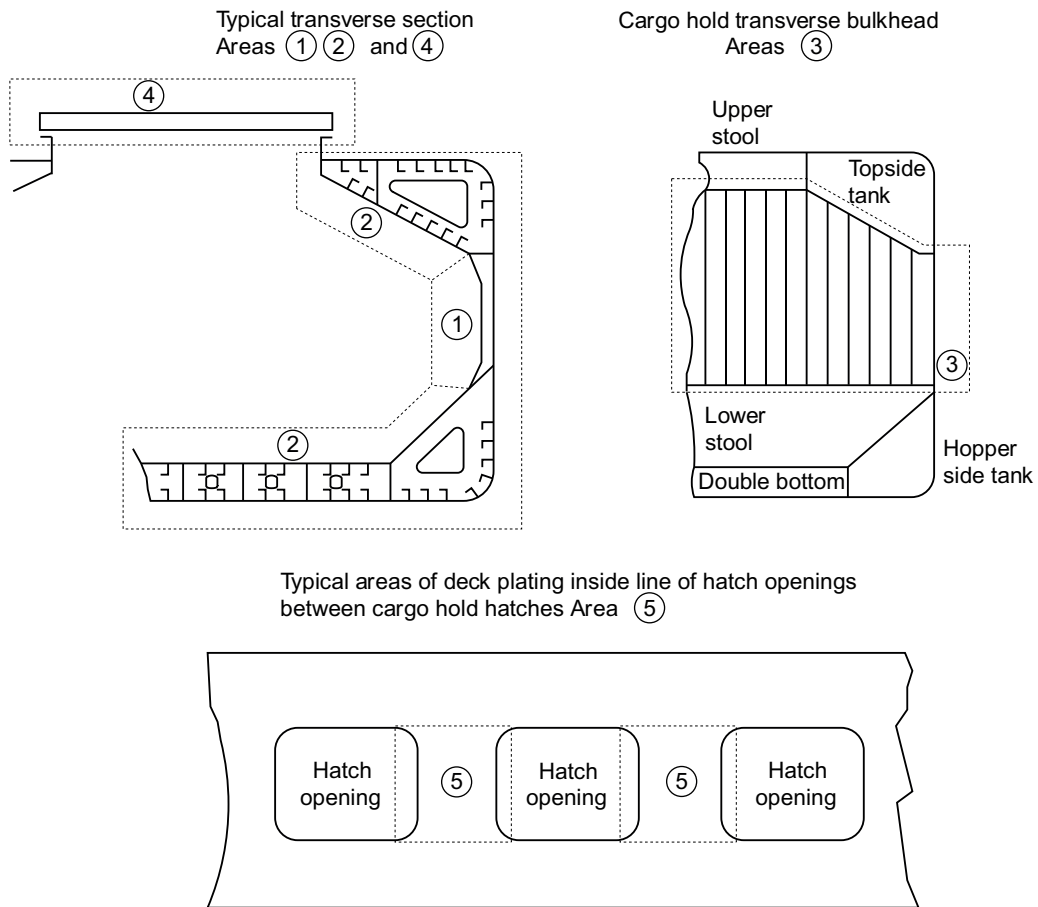


Figure 2 : Transverse bulkhead: close-up survey areas

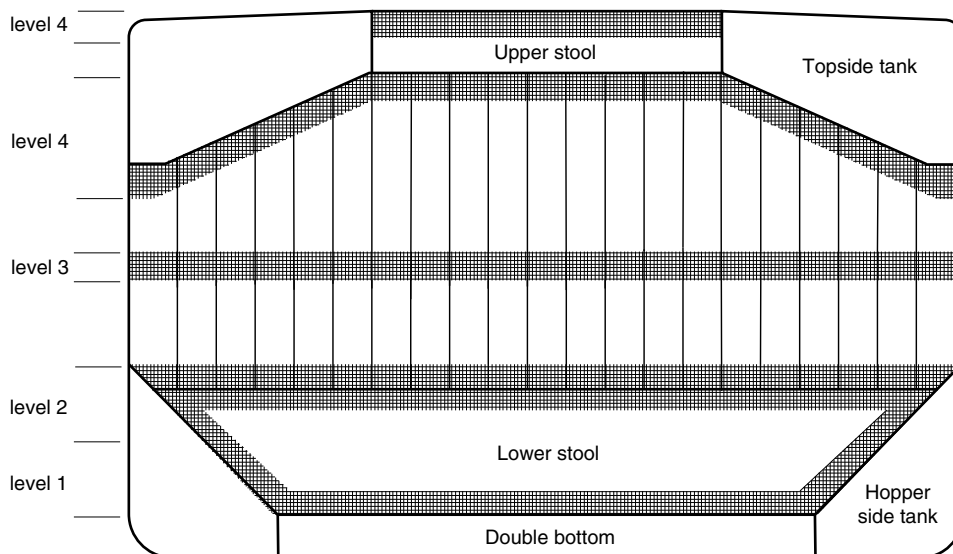


Table 9 : Requirements for close-up survey at class renewal survey of double skin bulk carriers, excluding ore carriers

Age of ship (in years at time of class renewal survey)			
Class renewal survey No.1 age ≤ 5	Class renewal survey No.2 5 < age ≤ 10	Class renewal survey No.3 10 < age ≤ 15	Class renewal survey No.4 and subsequent age > 15
One transverse web with associated plating and longitudinals in two representative water ballast tanks of each type (this is to include the foremost topside and double side water ballast tanks on either side) ①	One transverse web with associated plating and longitudinals as applicable in each water ballast tank ① Forward and aft transverse bulkheads including stiffening system in a transverse section including topside, hopper side and double side ballast tanks, on one side of the ship (i.e. port or starboard) ①	All transverse webs with associated plating and longitudinals as applicable in each water ballast tank ① All transverse bulkheads including stiffening system in each water ballast tank ①	All transverse webs with associated plating and longitudinals as applicable in each water ballast tank ① All transverse bulkheads including stiffening system in each water ballast tank ①
	25% of ordinary transverse frames for transverse framing system or 25% of longitudinals for longitudinal framing system on side shell and inner side plating at forward, middle and aft parts, in the foremost double side tanks ②	25% of ordinary transverse frames for transverse framing system or 25% of longitudinals for longitudinal framing system on side shell and inner side plating at forward, middle and aft parts, in all double side tanks ②	All ordinary transverse frames for transverse framing system or all longitudinals for longitudinal framing system on side shell and inner side plating at forward, middle and aft parts, in all double side tanks ②
Two selected cargo hold transverse bulkheads, including internal structure of upper and lower stools, where fitted ③	One transverse bulkhead in each cargo hold, including internal structure of upper and lower stools, where fitted ③	All cargo hold transverse bulkheads, including internal structure of upper and lower stools, where fitted ③	Areas ③ to ⑤ as for class renewal survey for ships between 10 and 15 years of age
All cargo hold hatch covers and coamings (platings and stiffeners) ④	All cargo hold hatch covers and coamings (platings and stiffeners) ④	All cargo hold hatch covers and coamings (platings and stiffeners) ④	
	All deck plating and underdeck structure inside line of hatch openings between all cargo hold hatches ⑤	All deck plating and underdeck structure inside line of hatch openings between all cargo hold hatches ⑤	
<p>Note 1: See Fig 3 and Fig 4 for areas ①, ②, ③, ④ and ⑤.</p> <p>① Transverse web frame or watertight transverse bulkhead in topside, hopper side and double side ballast tanks. In fore and aft peak tanks, transverse web frame means a complete transverse web frame ring including adjacent structural members.</p> <p>② Ordinary transverse frame in double side tanks.</p> <p>③ Cargo hold transverse bulkheads plating, stiffeners and girders.</p> <p>④ Cargo hold hatch covers and coamings. Subject to cargo hold hatch covers of approved design which structurally have no access to the internals, close-up survey/thickness measurement is to be done of the accessible parts of hatch cover structures.</p> <p>⑤ Deck plating and underdeck structure inside line of hatch openings between cargo hold hatches.</p> <p>Note 2: Close-up survey of transverse bulkheads to be carried out at four levels (see Fig 2):</p> <ul style="list-style-type: none"> - immediately above the inner bottom and immediately above the line of gussets (if fitted) and shedders for ships without lower tool - immediately above and below the lower stool shelf plate (for those ships fitted with lower stools), and immediately above the line of the shedder plates - about mid-height of the bulkhead - immediately below the upper deck plating and immediately adjacent to the upper wing tank, and immediately below the upper stool shelf plate (for those ships fitted with upper stools), or immediately below the topside tanks. 			

Table 10 : Requirements for close-up survey at class renewal survey of ore carriers

Age of ship (in years at time of class renewal survey)			
Class renewal survey No.1 age ≤ 5	Class renewal survey No.2 5 < age ≤ 10	Class renewal survey No.3 10 < age ≤ 15	Class renewal survey No.4 and subsequent age > 15
One web frame ring complete, including adjacent structural members, in a ballast wing tank ① One transverse bulkhead lower part, including girder system and adjacent structural members, in a ballast tank ①	All web frame rings complete, including adjacent structural members, in a ballast wing tank ① One deck transverse, including adjacent deck structural members, in each remaining ballast tank ① Forward and aft transverse bulkheads complete, including girder system and adjacent structural members, in a ballast wing tank ① One transverse bulkhead lower part, including girder system and adjacent structural members, in each remaining ballast tank ①	All web frame rings complete, including adjacent structural members, in each ballast tank ① All transverse bulkheads complete, including girder system and adjacent structural members, in each ballast tank ① One web frame ring complete, including adjacent structural members, in each wing void space ① Additional web frame rings in void spaces, as deemed necessary by the Society ①	As for class renewal survey for ships between 10 and 15 years of age
Two selected cargo hold transverse bulkheads, including internal structure of upper and lower stools, where fitted ③	One transverse bulkhead in each cargo hold, including internal structure of upper and lower stools, where fitted ③	All cargo hold transverse bulkheads, including internal structure of upper and lower stools, where fitted ③	Areas ③ to ⑤ as for class renewal survey for ships between 10 and 15 years of age
All cargo hold hatch covers and coamings (platings and stiffeners) ④	All cargo hold hatch covers and coamings (platings and stiffeners) ④	All cargo hold hatch covers and coamings (platings and stiffeners) ④	
	All deck plating and underdeck structure inside line of hatch openings between all cargo hold hatches ⑤	All deck plating and underdeck structure inside line of hatch openings between all cargo hold hatches ⑤	
<p>Note 1: See Fig 3 and Fig 4 for areas ①, ③, ④ and ⑤ (area ② not used).</p> <p>① Transverse web frame or watertight transverse bulkhead in ballast wing tanks and void spaces. In fore and aft peak tanks, transverse web frame means a complete transverse web frame ring including adjacent structural members.</p> <p>② (not used in this Table).</p> <p>③ Cargo hold transverse bulkheads plating, stiffeners and girders.</p> <p>④ Cargo hold hatch covers and coamings. Subject to cargo hold hatch covers of approved design which structurally have no access to the internals, close-up survey/thickness measurement is to be done of the accessible parts of hatch cover structures.</p> <p>⑤ Deck plating and underdeck structure inside line of hatch openings between cargo hold hatches.</p> <p>Note 2: Close-up survey of transverse bulkheads to be carried out at four levels (see Fig 2):</p> <p>Level 1 : Immediately above the inner bottom and immediately above the line of gussets (if fitted) and shedders for ships without lower stool.</p> <p>Level 2 : Immediately above and below the lower stool shelf plate (for those ships fitted with lower stools), and immediately above the line of the shedder plates.</p> <p>Level 3 : About mid-height of the bulkhead.</p> <p>Level 4 : Immediately below the upper deck plating and immediately adjacent to the upper wing tank, and immediately below the upper stool shelf plate (for those ships fitted with upper stools), or immediately below the topside tanks.</p>			

Figure 3 : Areas subject to close-up surveys and thickness measurements for double skin bulk carriers

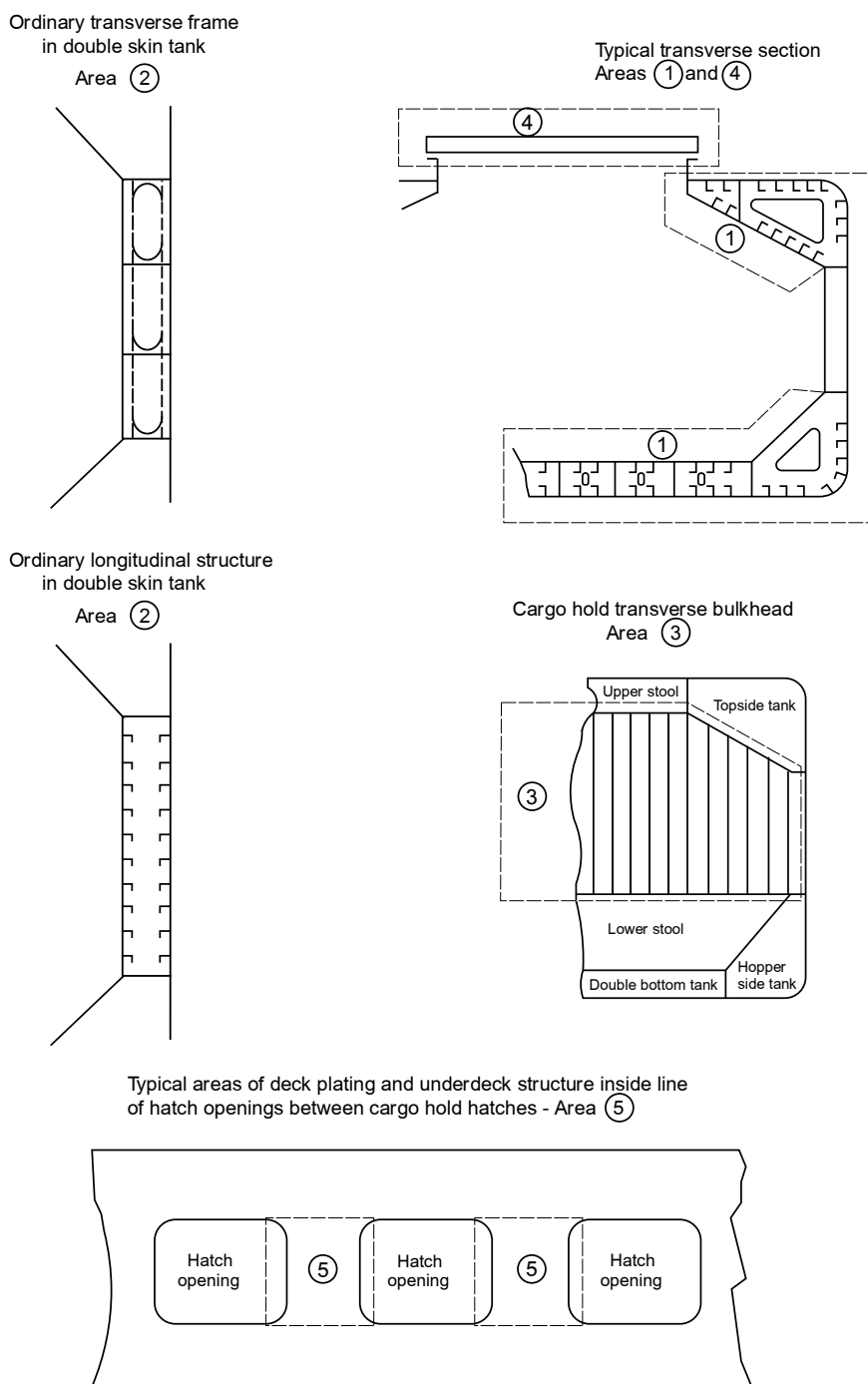


Figure 4 : Areas subject to close-up surveys and thickness measurements for ore carriers

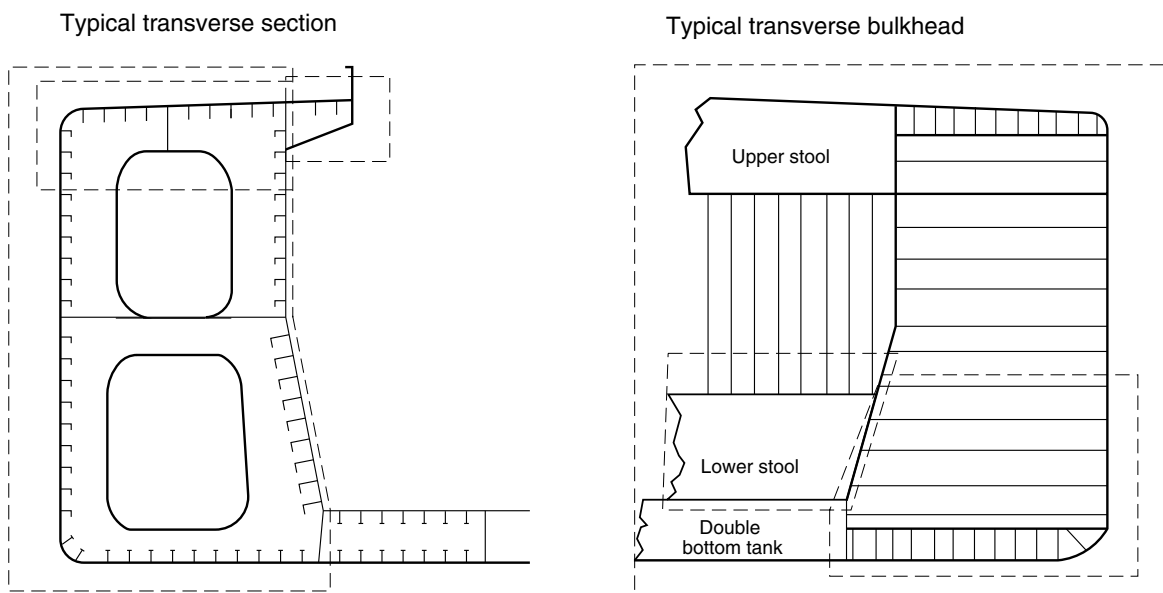


Table 11 : Requirements for thickness measurements at class renewal survey of bulk carriers

Age of ship (in years at time of class renewal survey)			
Class renewal survey No.1 age ≤ 5	Class renewal survey No.2 5 < age ≤ 10	Class renewal survey No.3 10 < age ≤ 15	Class renewal survey No.4 and subsequent age > 15
Suspect areas	Suspect areas	Suspect areas	Suspect areas
	Within the cargo length area: <ul style="list-style-type: none"> two transverse sections of deck plating outside line of cargo hatch openings (1) 	Within the cargo length area: <ul style="list-style-type: none"> each deck plate outside line of cargo hatch openings two transverse sections, one in the amidship area, outside line of cargo hatch openings, (1) 	Within the cargo length area: <ul style="list-style-type: none"> each deck plate outside line of cargo hatch openings three transverse sections, one in the amidship area, outside line of cargo hatch openings, (1) each bottom plate
	Measurements, for general assessment and recording of corrosion pattern, of those structural members subject to close-up survey according to Tab 8 or Tab 9 or Tab 10, as applicable	Measurements, for general assessment and recording of corrosion pattern, of those structural members subject to close-up survey according to Tab 8 or Tab 9 or Tab 10, as applicable	Measurements, for general assessment and recording of corrosion pattern, of those structural members subject to close-up survey according to Tab 8 or Tab 9 or Tab 10, as applicable
	Wind and water strakes in way of the transverse sections considered above	All wind and water strakes within the cargo area	All wind and water strakes, full length
	Selected wind and water strakes outside the cargo area	Selected wind and water strakes outside the cargo area	
		Additional thickness measurements given in Ch 6, Sec 2, [1.3] are to be taken on the transverse watertight bulkhead between the two foremost cargo holds on ships to which the requirements given in Ch 6, Sec 2, [1.1.1] apply	Additional thickness measurements given in Ch 6, Sec 2, [1.3] are to be taken on the transverse watertight bulkhead between the two foremost cargo holds on ships to which the requirements given in Ch 6, Sec 2, [1.1.1] apply
	Additional thickness measurements given in Ch 6, Sec 2, [5.3] are to be taken on the side shell frames and brackets on ships subject to compliance with Ch 6, Sec 2, [5]	Additional thickness measurements given in Ch 6, Sec 2, [5.3] are to be taken on the side shell frames and brackets on ships subject to compliance with Ch 6, Sec 2, [5]	Additional thickness measurements given in Ch 6, Sec 2, [5.3] are to be taken on the side shell frames and brackets on ships subject to compliance with Ch 6, Sec 2, [5]
(1) Transverse sections are to be chosen where largest reductions are suspected to occur or are revealed from deck plating measurements, one of which is to be in the midship area.			

**Table 12 : Requirements for extent of thickness measurements at those areas of substantial corrosion
Class renewal survey of single skin bulk carriers within the cargo area**

BOTTOM AND SIDE SHELL STRUCTURES		
Structural member	Extent of measurement	Pattern of measurement
Bottom and side shell plating	Suspect plate, plus 4 adjacent plates See other tables for particulars on gauging in way of tanks and cargo holds	5-point pattern for each panel between longitudinals
Bottom and side shell longitudinals	Minimum of 3 longitudinals in way of suspect areas	3 measurements in line across web 3 measurements on flange

**Table 13 : Requirements for extent of thickness measurements at those areas of substantial corrosion
Class renewal survey of single skin bulk carriers within the cargo area**

TRANSVERSE BULKHEADS IN CARGO HOLDS		
Structural member	Extent of measurement	Pattern of measurement
Lower stool	Transverse band within 25 mm of welded connection to inner bottom	5-point pattern between stiffeners over one metre length
	Transverse band within 25 mm of welded connection to shelf plate	5-point pattern between stiffeners over one metre length
Transverse bulkhead	Transverse band at approximately mid-height	5-point pattern over 1 m ² of plating
	Transverse band at part of bulkhead adjacent to upper deck or below upper stool shelf plate (for bulkheads fitted with lower stool)	5-point pattern over 1 m ² of plating

**Table 14 : Requirements for extent of thickness measurements at those areas of substantial corrosion
Class renewal survey of single skin bulk carriers within the cargo area**

DECK STRUCTURE AND HATCH COVERS		
Structural member	Extent of measurement	Pattern of measurement
Cross deck strip plating	Suspect cross deck strip plating	5-point pattern between underdeck stiffeners over one metre length
Underdeck stiffeners	Transverse members	5-point pattern at each end and mid-span
	Longitudinal members	5-point pattern on both web and flange
Hatch covers	Skirt: 3 locations on each side and each end	5-point pattern at each location
	3 longitudinal bands, outboard strakes (2) and centreline strake (1)	5-point measurement each band
Hatch coamings	Both sides and ends of coaming: one band lower 1/3 and one band upper 2/3 of coaming	5-point measurement each band
Topside water ballast tanks	Transverse watertight bulkhead:	
	(a) lower 1/3 of bulkhead	(a) 5-point pattern over 1 m ² of plating
	(b) upper 2/3 of bulkhead	(b) 5-point pattern over 1 m ² of plating
	(c) stiffeners	(c) 5-point pattern over 1 m length
Two representative transverse wash bulkheads:	(a) lower 1/3 of bulkhead	(a) 5-point pattern over 1 m ² of plating
	(b) upper 2/3 of bulkhead	(b) 5-point pattern over 1 m ² of plating
	(c) stiffeners	(c) 5-point pattern over 1 m length
Three representative bays of sloped plating:	(a) lower 1/3 of tank	(a) 5-point pattern over 1 m ² of plating
	(b) upper 2/3 of tank	(b) 5-point pattern over 1 m ² of plating
	Longitudinals: suspect and adjacent	5-point pattern both web and flange over 1 m length
Main deck plating	Suspect plates and adjacent	5-point pattern over 1 m ² of plating
Main deck longitudinals	Minimum of 3 longitudinals where plating measured	5-point pattern both web and flange over 1 m length
Web frames/transverses	Suspect plates	5-point pattern over 1 m ² of plating

**Table 15 : Requirements for extent of thickness measurements at those areas of substantial corrosion
Class renewal survey of single skin bulk carriers within the cargo area**

DOUBLE BOTTOM AND HOPPER STRUCTURE		
Structural member	Extent of measurement	Pattern of measurement
Inner bottom plating	Suspect plate plus all adjacent plates	5-point pattern for each panel between longitudinals over one metre length
Inner bottom longitudinals	Three longitudinals where plates measured	3 measurements in line across and 3 measurements on flange
Longitudinal girders and transverse floors	Suspect plates	5-point pattern over approximately 1 m ² of plating
Watertight bulkheads (floors and girders)	(a) lower 1/3 of tank (b) upper 2/3 of tank	(a) 5-point pattern over 1 m ² of plating (b) 5-point pattern alternate plates over 1 m ² of plating
Transverse web frames	Suspect plate	5-point pattern over 1 m ² of plating

**Table 16 : Requirements for extent of thickness measurements at those areas of substantial corrosion
Class renewal survey of single skin bulk carriers within the cargo area**

CARGO HOLDS		
Structural member	Extent of measurement	Pattern of measurement
Side shell frames	Suspect frame and each adjacent	(a) At each end and mid-span: 5-point pattern of both web and flange (b) 5-point pattern within 25 mm of welded attachment to both shell and lower sloped plate

**Table 17 : Requirements for extent of thickness measurements at those areas of substantial corrosion
Class renewal survey of double skin bulk carriers within the cargo length area**

BOTTOM, INNER BOTTOM AND HOPPER STRUCTURE		
Structural member	Extent of measurement	Pattern of measurement
Bottom, inner bottom and hopper structure plating	Minimum of 3 bays across double bottom tank, including aft bay Measurements around and under all suction bell mouths	5-point pattern for each panel between longitudinals and floors
Bottom, inner bottom and hopper structure longitudinals	Minimum of 3 longitudinals in each bay where bottom plating measured	3 measurements in line across flange and 3 measurements on the vertical web
Bottom girders, including the watertight ones	At fore and aft watertight floors and in centre of tanks	Vertical line of single measurements on girder plating with 1 measurement between each panel stiffener, or a minimum of 3 measurements
Bottom floors, including the watertight ones	3 floors in the bays where bottom plating measured, with measurements at both ends and middle	5-point pattern over 2 square metre area
Hopper structure web framing	3 floors in the bays where bottom plating measured	5-point pattern over 1 square metre of plating Single measurements on flange
Hopper structure transverse watertight bulkhead or swash bulkhead	<ul style="list-style-type: none"> lower 1/3 of bulkhead upper 2/3 of bulkhead stiffeners (minimum of 3) 	5-point pattern over 1 square metre of plating 5-point pattern over 2 square metre of plating for web, 5-point pattern over span (2 measurements across web at each end and one at centre of span). For flange, single measurements at each end and centre of span
Panel stiffening	Where applicable	Single measurements

4.7.3 Boundaries of ballast tanks are to be tested with a head of liquid to the top of air pipes.

Boundaries of ballast holds are to be tested with a head of liquid to near to the top of hatches.

Boundaries of fuel oil tanks are to be tested with a head of liquid to the highest point that liquid will rise under service conditions. Tank testing of fuel oil tanks may be specially considered based on a satisfactory external examination of

the tank boundaries, and a confirmation from the Master stating that the pressure testing has been carried out according to the requirements with satisfactory results.

4.7.4 The testing of double bottom tanks and other spaces not designed for the carriage of liquid may be omitted, provided a satisfactory internal examination together with an examination of the tanktop is carried out.

**Table 18 : Requirements for extent of thickness measurements at those areas of substantial corrosion
Class renewal survey of double skin bulk carriers within the cargo length area**

DECK STRUCTURE INCLUDING CROSS STRIPS, MAIN CARGO HATCHWAYS, HATCH COAMINGS AND TOPSIDE TANKS		
Structural member	Extent of measurement	Pattern of measurement
Cross deck strip plating	Suspect cross deck strip plating	5-point pattern between underdeck stiffeners over 1 metre length
Underdeck stiffeners	Transverse members Longitudinal members	5-point pattern at each end and mid span 5-point pattern on both web and flange
Hatch covers	Side and end skirts, each 3 locations 3 longitudinal bands: 2 outboard strakes and 1 centreline strake	5-point pattern at each location 5-point measurement each band
Hatch coamings	Each side and end of coaming, one band lower 1/3, one band upper 2/3 of coaming	5-point measurement each band i.e. end or side coaming
Topside ballast tanks	a) Watertight transverse bulkheads: <ul style="list-style-type: none"> • lower 1/3 of bulkhead • upper 2/3 of bulkhead • stiffeners 	5-point pattern over 1 square metre of plating 5-point pattern over 1 square metre of plating 5-point pattern over 1 metre length
Topside ballast tanks	b) Two representative swash transverse bulkheads: <ul style="list-style-type: none"> • lower 1/3 of bulkhead • upper 2/3 of bulkhead • stiffeners 	5-point pattern over 1 square metre of plating 5-point pattern over 1 square metre of plating 5-point pattern over 1 metre length
Topside ballast tanks	c) Three representative bays of slope plating: <ul style="list-style-type: none"> • lower 1/3 of tank • upper 2/3 of tank 	5-point pattern over 1 square metre of plating 5-point pattern over 1 square metre of plating
Topside ballast tanks	d) Longitudinals, suspect and adjacent	5-point pattern on both web and flange over 1 metre length
Main deck plating	Suspect plates and adjacent (4)	5-point pattern over 1 square metre of plating
Main deck longitudinals	Suspect plates	5-point pattern on both web and flange over 1 metre length
Web frames / Transverses	Suspect plates	5-point pattern over 1 square metre

**Table 19 : Requirements for extent of thickness measurements at those areas of substantial corrosion
Class renewal survey of double skin bulk carriers within the cargo length area**

STRUCTURE IN DOUBLE SIDE SPACES OF DOUBLE SKIN BULK CARRIERS INCLUDING WING VOID SPACES OF ORE CARRIERS		
Structural member	Extent of measurement	Pattern of measurement
Side shell and inner plating: <ul style="list-style-type: none"> • upper strake and strakes in way of horizontal girders • all other strakes 	<ul style="list-style-type: none"> • plating between each pair of transverse frames/longitudinals in a minimum of 3 bays (along the tank) • plating between every third pair of longitudinals in same 3 bays 	<ul style="list-style-type: none"> • Single measurement • Single measurement
Side shell and inner side transverse frames / longitudinals on: <ul style="list-style-type: none"> • upper strake • all other strakes 	<ul style="list-style-type: none"> • each transverse frame/longitudinal in same 3 bays • every third transverse frame/longitudinal in same 3 bays 	<ul style="list-style-type: none"> • 3 measurements across web and 1 measurement on flange • 3 measurements across web and 1 measurement on flange
Transverse frames / longitudinals: <ul style="list-style-type: none"> • brackets 	Minimum of 3 at top, middle and bottom of tank in same 3 bays	5-point pattern over area of bracket
Vertical web and transverse bulkheads: <ul style="list-style-type: none"> • strakes in way of horizontal girders • other strakes 	<ul style="list-style-type: none"> • minimum of 2 webs and both transverse bulkheads • minimum of 2 webs and both transverse bulkheads 	<ul style="list-style-type: none"> • 5-point pattern over approx. 2 square metre area • 2 measurements between each pair of vertical stiffeners
Horizontal girders	Plating on each girder in a minimum of 3 bays	2 measurements between each pair of longitudinal girder stiffeners
Panel stiffening	Where applicable	Single measurements

**Table 20 : Requirements for extent of thickness measurements at those areas of substantial corrosion
Class renewal survey of double skin bulk carriers within the cargo length area**

TRANSVERSE BULKHEADS IN CARGO HOLDS		
Structural member	Extent of measurement	Pattern of measurement
Lower stool, where fitted	<ul style="list-style-type: none"> • transverse band within 25 mm of welded connection to inner bottom • transverse band within 25 mm of welded connection to shelf plate 	<ul style="list-style-type: none"> • 5-point pattern between stiffeners over 1 metre length • 5-point pattern between stiffeners over 1 metre length
Transverse bulkheads	<ul style="list-style-type: none"> • transverse band at approx. mid height • transverse band at part of bulkhead adjacent to upper deck or below upper stool shelf plate (for those ships fitted with upper stools) 	<ul style="list-style-type: none"> • 5-point pattern over 1 square metre of plating • 5-point pattern over 1 square metre of plating

SECTION 3

OIL TANKERS AND COMBINATION CARRIERS

1 General

1.1 Application

1.1.1 The requirements of this Section apply to all self-propelled ships which have been assigned one of the following service notations:

- **oil tanker ESP** (whether of single or double hull construction)
- **combination carrier/OBO ESP**
- **combination carrier/OOC ESP**.

Note 1: A double hull oil tanker is a ship which is constructed primarily for the carriage of oil (MARPOL Annex I cargoes) in bulk, which have the cargo tanks protected by a double hull which extends for the entire length of the cargo area, consisting of double sides and double bottom spaces for the carriage of water ballast or void spaces. The requirements of this Section for double hull tankers are also applicable to existing double hull tankers not complying with MARPOL Regulation 13F, but having a U-shaped midship section.

1.1.2 Ships granted with the service notation **oil storage service** are only concerned by the requirements laid down in [6] for class hull renewal surveys.

1.1.3 The requirements for hull surveys apply to the surveys of the hull structure and piping systems in way of cargo tanks, pump rooms, cofferdams, pipe tunnels and void spaces within the cargo area and all ballast tanks. They are additional to the requirements applicable to the remainder of the ship, given in Part A, Chapter 3 according to the relevant surveys.

1.1.4 The requirements contain the minimum extent of examination, thickness measurements and tank testing. When substantial corrosion, as defined in Ch 2, Sec 2, [2.2.7], and/or structural defects are found, the survey is to be extended and is to include additional close-up surveys when necessary.

1.1.5 In any kind of survey, i.e. class renewal, intermediate, annual or other surveys having the same scope, thickness measurements, when required by Tab 3, of structures in areas where close-up surveys are required are to be carried out simultaneously with close-up surveys.

1.1.6 In all cases the extent of thickness measurements is to be sufficient as to represent the actual average condition.

1.1.7 When, in any survey, thickness measurements are required:

- the procedure detailed in Ch 2, Sec 2, [2.3] is to be applied
- the thickness measurement firm is to be part of the survey planning meeting to be held prior to commencing the survey.

1.1.8 The requirements for machinery surveys apply to surveys of the machinery and equipment in the cargo area or dedicated to cargo service systems and are additional to those given in Part A, Chapter 3 for all ships.

1.2 Documentation on board

1.2.1 The Owner is to obtain, supply and maintain documentation on board as specified in [1.2.2] and [1.2.3], which is to be readily available for examination by the Surveyor. The documentation is to be kept on board for the lifetime of the ship.

For oil tankers subject to SOLAS Chapter II-1 Part A-1 Regulation 3-10, the Owner is to arrange the updating of the Ship Construction File (SCF) throughout the ship's life whenever a modification of the documentation included in the SCF has taken place. Documented procedures for updating the SCF are to be included within the Safety Management System.

1.2.2 A survey report file is to be a part of the documentation on board consisting of:

- reports of structural surveys
- hull condition evaluation report (summarising the results of class renewal surveys)
- thickness measurement reports.

The survey report file is also to be available in the Owner's management office.

1.2.3 The following additional supporting documentation is to be available on board:

- main structural plans of cargo and ballast tanks (for CSR ships, these plans are to include, for each structural element, both the as-built and the renewal thicknesses. Any thickness for voluntary addition is also to be clearly indicated on the plans. The midship section plan to be supplied on board the ship is to include the minimum allowable hull girder sectional properties for the tank transverse section in all cargo tanks)
- previous repair history
- cargo and ballast history
- extent of use of inert gas system and tank cleaning procedures
- ship's personnel reports on:
 - structural deterioration/defects in general
 - leakage in bulkheads and piping systems
 - condition of coatings or corrosion prevention systems, if any
- survey program, as required in [6.1], until such time as the class renewal survey or intermediate survey, as applicable, has been completed
- any other information that may help to identify critical structural areas and/or suspect areas requiring inspection.

1.2.4 For oil tankers subject to SOLAS Chapter II-1 Part A-1 Regulation 3-10, the Ship Construction File (SCF), limited to the items to be retained onboard, is to be available on board.

1.2.5 Prior to survey, the Surveyor examines the documentation on board and its contents, which are used as a basis for the survey.

1.2.6 For oil tankers subject to SOLAS Chapter II-1 Part A-1 Regulation 3-10:

- on completion of the survey, the Surveyor is to verify that the update of the Ship Construction File (SCF) has been done whenever a modification of the documentation included in the SCF has taken place.
- for the SCF stored on board ship, the Surveyor is to examine the information on board ship. In cases where any major event, including, but not limited to, substantial repair and conversion, or any modification of the ship structures, the Surveyor is also to verify that the updated information is kept on board the ship. If the updating of the SCF onboard is not completed at the time of survey, the Surveyor records it and requires confirmation at the next periodical survey
- for the SCF stored on shore archive, the Surveyor is to examine the list of information included on shore archive. In cases where any major event, including, but not limited to, substantial repair and conversion, or any modification of the ship structures, the Surveyor is also to verify that the updated information is stored on shore archive by examining the list of information included on shore archive or kept on board the ship. In addition, the surveyor is to confirm that the service contract with of the Archive Center is valid. If the updating of the SCF Supplement ashore is not completed at the time of survey, the Surveyor records it and requires confirmation at the next periodical survey.

1.2.7 For oil tankers subject to SOLAS Chapter II-1 Part A-1 Regulation 3-10, on completion of the survey, the Surveyor is to verify that any addition and/or renewal of materials used for the construction of the hull structure is/are documented within the SCF inventory list.

1.3 Reporting and evaluation of surveys

1.3.1 The data and information on the structural condition of the ship collected during survey are evaluated for acceptability and structural integrity of the ship's cargo area.

1.3.2 In case of oil tankers of 130 m in length and upwards (as defined in the International Convention on Load Lines in force), the ship's longitudinal strength is to be evaluated by using the thickness of structural members measured, renewed and reinforced, as appropriate, during the class renewal survey carried out after the ship reached 10 years of age in accordance with the criteria for longitudinal strength of the ship's hull girder for oil tankers specified in Ch 4, App 1.

The final result of evaluation of the ship's longitudinal strength, after renewal or reinforcement work of structural members, if carried out as a result of initial evaluation, is to be reported as a part of the hull condition evaluation report.

1.3.3 When a survey is split between different survey stations, a report is to be made for each portion of the survey. A list of items examined and/or tested (pressure testing, thickness measurements etc.) and an indication of whether the item has been credited, are to be made available to the next attending Surveyor(s), prior to continuing or completing the survey.

1.3.4 A hull condition evaluation report (summarizing the results of class renewal surveys) is issued by the Society to the Owner, who is to place it on board the ship for reference at future surveys. The hull condition evaluation report is endorsed by the Society.

1.4 Conditions for survey

1.4.1 In order to enable the attending surveyor(s) to carry out the survey, provisions for proper and safe access are to be agreed between the Owner and the Society.

Details of the means of access are to be provided in the survey planning questionnaire.

In cases where the provisions of safety and required access are judged by the attending surveyor(s) not to be adequate, the survey of the spaces involved is not to proceed.

1.5 Access to structures

1.5.1 For overall survey, means are to be provided to enable the surveyor(s) to examine the hull structure in a safe and practical way.

1.5.2 For close-up survey, one or more of the following means for access, acceptable to the Surveyor, is to be provided:

- permanent staging and passages through structures
- temporary staging and passages through structures
- hydraulic arm vehicles such as conventional cherry pickers, lifts and movable platforms
- boats or rafts
- portable ladders
- other equivalent means.

2 Annual survey - Hull items

2.1 General

2.1.1 The survey is to consist of an examination for the purpose of ensuring, as far as practicable, that the hull and piping are maintained in a satisfactory condition and should take into account the service history, condition and extent of the corrosion prevention system of ballast tanks and areas identified in the survey report file.

2.2 Weather decks

2.2.1 The survey is to include:

- examination of cargo tank openings, including gaskets, covers, coamings and screens
- examination of cargo tank pressure/vacuum valves and flame screens

- examination of flame screens on vents to all bunker, oily-ballast and oily slop tanks and void spaces
- examination of cargo, crude oil washing, bunker, ballast and vent piping systems, including remote control valves, safety valves and various safety devices, as well as vent masts and headers
- confirmation that wheelhouse doors and windows, sidescuttles and windows in superstructure and deckhouse ends facing the cargo area are in satisfactory condition
- confirmation that the requisite arrangements to regain steering capability in the event of the prescribed single failure are being maintained
- examination of the cargo tank venting, purging and gas freeing systems and other ventilation systems
- examination, for oil tankers of 150 m in length and above, where appropriate, of the ship's structure in accordance with the Ship Construction File, taking into account identified areas that need special attention.
- examination of watertight penetrations as far as practicable.

2.3 Cargo pump rooms and pipe tunnels

2.3.1 The survey is to include:

- examination of all pump room bulkheads and pipe tunnels (if any) for signs of oil leakage or fractures and, in particular, the sealing arrangements of penetrations in these bulkheads
- examination of the condition of all piping systems, in cargo pump rooms and pipe tunnels (if any)
- examination of the bilge and ballast arrangements.

2.4 Ballast tanks

2.4.1 Ballast tanks are to be internally examined when required as a consequence of the results of the class renewal survey or the intermediate survey.

2.4.2 When considered necessary by the Surveyor, or when extensive corrosion exists, thickness measurements are to be carried out and if the results of these thickness measurements indicate that substantial corrosion is found, the extent of thickness measurements is to be increased in accordance with the requirements of Tab 4 or Tab 5. These extended thickness measurements are to be carried out before the survey is credited as completed. Suspect areas identified at previous surveys are to be examined. Areas of substantial corrosion identified at previous surveys are to have thickness measurements taken.

2.4.3 For ships built under the Common Structural Rules, the identified substantial corrosion areas are required to be examined and additional thickness measurements are to be carried out.

2.4.4 For ships with dedicated ballast water tanks, confirmation, through documentary evidence, that the corrosion prevention system fitted to these dedicated ballast water tanks has been maintained.

2.5 Emergency towing arrangement

2.5.1 The Owner or his representative is to declare to the attending Surveyor that no significant alterations have been made, without prior approval from the Society, to the equipment and arrangements fitted on board in accordance with the provisions given in Pt B, Ch 9, Sec 4, [3].

2.5.2 The survey is to include:

- an examination, as far as practicable, of the emergency towing arrangement
- confirmation that the aft towing arrangement is pre-rigged and forward chafing gear is secured to the strong-point
- confirmation of the proper functioning of the light, where it is provided, on the pick-up gear marker buoy.

2.6 Safe access to tanker bows

2.6.1 The access to bow arrangement is to be examined, as applicable.

2.7 Means of access

2.7.1 When appropriate and as far as practicable when examining internal spaces, the condition of the means of access to cargo and other spaces is to be ascertained.

2.8 Coating systems

2.8.1 When appropriate, confirmation that the coating system in cargo oil tanks of crude oil tankers, is maintained and that in-service maintenance and repair activities are recorded in the coating technical file.

3 Annual survey - Cargo machinery items

3.1 Cargo area and cargo pump rooms

3.1.1 The Owner or his representative is to declare to the attending Surveyor that no modifications or alterations which might impair safety have been made to the various installations in dangerous zones without prior approval from the Society.

The survey is to include:

- check of the protection of cargo pump room, as applicable, and in particular, check of:
 - temperature sensing devices for bulkheads glands and alarms
 - interlock between lighting and ventilation
 - gas detection system
 - bilge level monitoring devices and alarms
- examination of the emergency lighting in cargo pump rooms of ships constructed after 1st July 2002
- confirmation that potential sources of ignition in or near the cargo pump rooms, such as loose gear, excessive product in bilge, excessive vapours, combustible materials, etc., are eliminated and that access ladders are in satisfactory condition

- examination, as far as practicable, of cargo, bilge, ballast and stripping pumps for excessive gland seal leakage, verification of proper operation of electrical and mechanical remote operating and shutdown devices and operation of the pump room bilge system, and checking that pump foundations are intact
- confirmation that the ventilation system, including portable equipment, if any, of all spaces in the cargo area (including cargo pump rooms) is operational, ducting is intact, dampers are operational and screens are clean
- confirmation that electrical equipment in dangerous zones, cargo pump rooms and other spaces is in satisfactory condition and has been properly maintained
- confirmation that the remote operation of the cargo pump room bilge system is satisfactory
- examination of the cargo heating system, as appropriate
- examination of the cargo-transfer arrangement and confirmation that the ship's cargo hoses are suitable for their intended purpose and in satisfactory condition
- confirmation that any special arrangement made for bow or stern loading/unloading is in satisfactory condition and test of the means of communication and remote shutdown of the cargo pumps.

3.2 Instrumentation and safety devices

3.2.1 The survey is to include:

- examination of cargo tank gauging devices, high level alarms and valves associated with overflow control
- verification that installed pressure gauges on cargo discharge lines are properly operational
- confirmation that the required gas detection instruments are on board and satisfactory arrangements have been made for the supply of any required vapour detection tubes
- confirmation that at least one (1) portable instrument for measuring oxygen and one (1) for measuring flammable vapour concentrations, together with a sufficient set of spares, and suitable means of calibration of these instruments are available on board
- examination of the arrangements for gas measurement in double-hull spaces and double bottom spaces, including the fitting of permanent gas sampling lines, where appropriate
- examination as far as possible, and testing of the fixed hydrocarbon gas detection system
- confirmation that devices provided for measuring the temperature of the cargo, if any, operate satisfactorily.

3.3 Fire-fighting systems in cargo area

3.3.1 The survey is to include:

- external examination of piping and cut-out valves of fixed fire-fighting systems related to cargo tanks and cargo pump rooms
- confirmation, as far as practicable and when appropriate, that the remote means for closing the various openings are operable
- examination of the appropriate portable fire-extinguishing equipment for the cargoes to be carried in accord-

ance with the relevant requirements given in Ch 3, Sec 1, [3.4.3]

- examination of fire-fighting systems of any type fitted on board such as deck foam, water-spraying, etc., as applicable in accordance with the relevant requirements given in Ch 3, Sec 1, [3.4].

3.4 Inert gas system

3.4.1 The survey is to include:

- external examination of the whole system, to check the condition of all piping, including vent piping above the upper deck in the cargo tank area and overboard discharges through the shell so far as practicable, and associated components to verify, in particular, the absence of signs of corrosion and leakage of gas, water or other liquid from inert gas and water piping systems or from the pressure/vacuum breaking device
- check of proper operation of both inert gas blowers
- check of proper operation of ventilation system required for scrubber room (if any)
- check of deck water seal for automatic water filling and draining
- check of absence of water carry over in the inert gas from the deck water seal and check of the condition of the non-return valve
- check of proper operation of all remotely operated or automatically controlled valves and, in particular, of the flue gas isolating valve located on the inert gas supply main after the blowers
- check of proper operation of the interlocking feature fitted to prevent soot blowers from operating when the inert gas system is working
- check that the gas pressure regulating valve automatically closes when gas blowers are stopped
- check, as far as practicable and using simulated conditions where necessary, of the following alarms and safety devices of the inert gas system:
 - high oxygen content of gas in the inert gas main
 - low gas pressure in the inert gas main
 - low pressure in the supply to the deck water seal
 - high temperature of gas in the inert gas main, including automatic shutdown devices
 - low water pressure to the scrubber, including automatic shutdown devices
 - accuracy of portable and fixed oxygen measuring equipment by means of calibration gases
 - high water level in the scrubber, including automatic shutdown devices
 - failure of the inert gas blowers
 - failure of the power supply to the automatic control system for the gas regulating valve and to the instrumentation for continuous indication and permanent recording of pressure and oxygen content in the inert gas main
 - high pressure of gas in the inert gas main
- check, when practicable, of the proper operation of the inert gas system on completion of the checks listed above.

4 Intermediate survey - Hull items

4.1 General

4.1.1 The survey of weather decks is to include:

- examination, as far as applicable, of cargo, crude oil washing, bunker, ballast, steam and vent piping systems as well as vent masts and headers. If upon examination there is any doubt as to the condition of the piping, the piping may be required to be pressure tested, thickness measured or both. Particular attention is to be paid to repairs such as welded doublers
- confirmation, if applicable, that cargo pipes are electrically bonded to the hull
- examination of vent line drainage arrangements.

4.1.2 For ships built under the Common Structural Rules, the identified substantial corrosion areas are required to be examined and additional thickness measurements are to be carried out.

4.2 Ships between 5 and 10 years of age

4.2.1 For single hull oil tankers and combination carriers, all ballast tanks are to be examined.

When considered necessary by the Surveyor, thickness measurements and testing are to be carried out to ensure that the structural integrity remains effective.

4.2.2 For double hull oil tankers, an overall survey of representative salt water ballast tanks selected by the Surveyor is to be carried out.

If such overall survey reveals no visible structural defects, the examination may be limited to a verification that the hard protective coating remains in good condition.

4.2.3 A ballast tank is to be examined at subsequent annual surveys where:

- a hard protective coating has not been applied from the time of construction, or
- a soft or semi-hard coating has been applied, or
- substantial corrosion is found within the tank, or
- the hard protective coating is found to be in less than good condition and the hard protective coating is not repaired to the satisfaction of the Surveyor.

Thickness measurement is to be carried out as deemed necessary by the Surveyor.

4.2.4 In addition to the requirements above, suspect areas identified at previous surveys are to be examined.

4.3 Ships between 10 and 15 years of age

4.3.1 The scope of intermediate survey of ships between 10 and 15 years of age is the scope of the preceding class renewal survey of hull, as detailed in [6] with bottom survey in dry condition or bottom in water survey as applicable.

However, pressure testing of all cargo and ballast tanks and the requirements for longitudinal strength evaluation of hull girder as required in [6.5.5] are not required unless deemed necessary by the attending Surveyor.

4.4 Ships over 15 years of age

4.4.1 The scope of intermediate survey of ships over 15 years of age is the scope of the preceding class renewal survey of hull, as detailed in [6] with bottom survey in dry condition, except that pressure testing of ballast and cargo tanks and the requirements for longitudinal strength evaluation of hull girder as required in [6.5.5] is not required unless deemed necessary by the Surveyor.

The overall and close-up surveys and thickness measurements, as applicable, of the lower portions of the cargo tanks and water ballast tanks are to be carried out during the bottom survey in accordance with the applicable requirements for intermediate surveys, if not already performed.

Lower portions of the cargo and ballast tanks are considered to be the parts below light ballast water line.

The requirements of [6.8] are not applicable.

5 Intermediate survey - Cargo machinery items

5.1 Cargo area and cargo pump rooms

5.1.1 A general examination of the electrical equipment and cables in dangerous zones such as cargo pump rooms and areas adjacent to cargo tanks is to be carried out for defective and non-certified safe type electrical equipment and fixtures, non-approved lighting and fixtures, and improperly installed or defective or dead-end wiring.

5.1.2 The electrical insulation resistance of the electrical equipment and circuits terminating in or passing through the dangerous zones is to be tested; however, in cases where a proper record of testing is maintained, consideration may be given to accepting recent test readings effected by the ship's personnel.

5.1.3 The satisfactory condition of the cargo heating system is to be verified.

5.2 Inert gas system

5.2.1 The following is to be carried out:

- main parts such as the scrubber, washing machines, blowers, deck water seal and non-return valve are to be opened out as considered necessary and examined
- gas distribution lines and shut-off valves, including soot blower interlocking devices, are to be examined as deemed necessary
- all automatic shutdown devices and alarms are to be examined and tested.

6 Class renewal survey - Hull items

6.1 Survey programme and preparation for hull survey

6.1.1 The Owner in cooperation with the Society is to work out a specific Survey Programme prior to the commencement of any part of:

- the class renewal survey
- the intermediate survey for oil tankers over 10 years of age.

The survey programme is to be in a written format. The survey is not to commence until the Survey Programme has been agreed.

Prior to the development of the Survey Programme, the survey planning questionnaire is to be completed by the Owner and forwarded to the Society.

The survey programme at intermediate survey may consist of the survey programme at the previous class renewal survey supplemented by the hull condition evaluation report of that class renewal survey and later relevant survey reports.

The survey programme is to be worked out taking into account any amendments to the survey requirements after the last class renewal survey carried out.

6.1.2 In developing the survey programme, the following documentation is to be collected and consulted with a view to selecting tanks, areas and structural elements to be examined:

- a) survey status and basic ship information
- b) documentation on board, as described in [1.2.2] and [1.2.3]
- c) main structural plans of cargo and ballast tanks (scantlings drawings), including information regarding use of high-tensile steels (HTS)
- d) Hull Condition Evaluation Report
- e) relevant previous damage and repair history
- f) relevant previous survey and inspection reports from both the Society and the Owner
- g) cargo and ballast history for the last 3 years, including carriage of cargo under heated conditions
- h) details of the inert gas plant and tank cleaning procedures
- i) information and other relevant data regarding conversion or modification of the ship's cargo and ballast tanks since the time of construction
- j) description and history of the coating and corrosion protection system (including previous class notations), if any
- k) inspections by the Owner's personnel during the last 3 years with reference to structural deterioration in general, leakages in tank boundaries and piping and condition of the coating and corrosion protection system if any
- l) information regarding the relevant maintenance level during operation including port state control reports of inspection containing hull related deficiencies, Safety

Management System non-conformities relating to hull maintenance, including the associated corrective action(s), and

- m) any other information that will help identify suspect areas and critical structural areas.

6.1.3 The submitted survey programme is to account for and comply, as a minimum, with the requirements of Tab 1 or Tab 2, Tab 3 and Tab 6, for close-up survey, thickness measurements and tank testing, respectively, and is to include relevant information including at least:

- a) basic ship information and particulars
- b) main structural plans of cargo and ballast tanks (scantling drawings), including information regarding use of high tensile steels (HTS)
- c) arrangement of tanks
- d) list of tanks with information on their use, extent of coatings and corrosion protection systems
- e) conditions for survey (e.g., information regarding tank cleaning, gas freeing, ventilation, lighting, etc.)
- f) provisions and methods for access to structures
- g) equipment for surveys
- h) identification of tanks and areas for close-up survey (see [6.4])
- i) identification of areas and sections for thickness measurement (see [6.5])
- j) identification of tanks for tank testing (see [6.6])
- k) identification of the thickness measurement firm
- l) damage experience related to the ship in question, and
- m) critical structural areas and suspect areas, where relevant.

6.1.4 The Society is to advise the Owner of the maximum acceptable structural corrosion diminution levels applicable to the ship.

6.2 Survey planning meeting

6.2.1 The establishment of proper preparation and the close co-operation between the attending surveyor(s) and the owner's representatives onboard prior to and during the survey are an essential part in the safe and efficient conduct of the survey. During the survey on board, safety meetings are to be held regularly.

6.2.2 Prior to commencement of any part of the renewal and intermediate survey, a survey planning meeting is to be held between the attending surveyor(s), the owner's representative in attendance, the thickness measurement firm operator (as applicable) and the master of the ship or an appropriately qualified representative appointed by the master or Company for the purpose to ascertain that all the arrangements envisaged in the survey programme are in place, so as to ensure the safe and efficient conduct of the survey work to be carried out. See also [1.1.7].

Table 1 : Close-up survey at class renewal survey of single hull oil tankers and combination carriers

Age of ship (in years at time of class renewal survey)			
Class renewal survey No.1 age ≤ 5	Class renewal survey No.2 5 < age ≤ 10	Class renewal survey No.3 10 < age ≤ 15	Class renewal survey No.4 and subsequent age > 15
One web frame ring ①: - in a ballast wing tank, if any, or - in a cargo wing tank used primarily for water ballast	All web frame rings ①: - in a ballast wing tank, if any, or - in a cargo wing tank used primarily for water ballast	All web frame rings ① in all ballast tanks All web frame rings ① in a cargo wing tank A minimum of 30% (1) of all web frame rings ① in each remaining cargo wing tank	As class renewal survey for ships between 10 and 15 years of age Additional transverse areas as deemed necessary by the Society
One deck transverse ② in a cargo tank	One deck transverse ②: - in each remaining ballast tank, if any - in a cargo wing tank - in two cargo centre tanks		
	Both transverse bulkheads ③: - in a wing ballast tank, if any, or - in a cargo wing tank used primarily for water ballast	All transverse bulkheads (area ③) in all cargo and ballast tanks	
One transverse bulkhead ④ in a ballast tank One transverse bulkhead ④ in a cargo wing tank One transverse bulkhead ④ in a cargo centre tank	One transverse bulkhead ④ in each remaining ballast tank One transverse bulkhead ④ in a cargo wing tank One transverse bulkhead ④ in two cargo centre tanks		
		A minimum of 30% (1) of deck and bottom transverses ⑤ in each cargo centre tank	
		Additional web frame ring(s) ①, as considered necessary by the Surveyor	
<p>(1) The 30% is to be rounded up to the next whole integer.</p> <p>Note 1: See Fig 1 or Fig 2 for areas ①, ②, ③, ④ and ⑤.</p> <p>① Complete transverse web frame ring including adjacent structural member.</p> <p>② Deck transverse including adjacent deck structural members.</p> <p>③ Transverse bulkhead complete, including girder system and adjacent structural members.</p> <p>④ Transverse bulkhead lower part, including girder system and adjacent structural members.</p> <p>⑤ Deck and bottom transverse, including adjacent structural members.</p>			

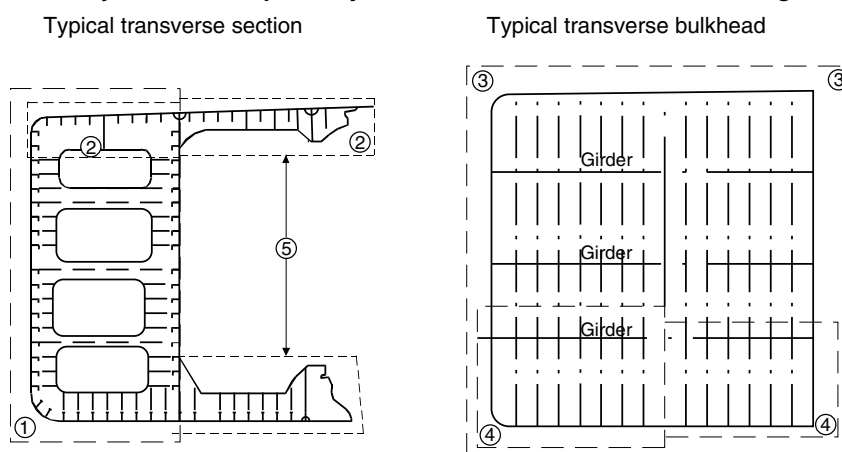
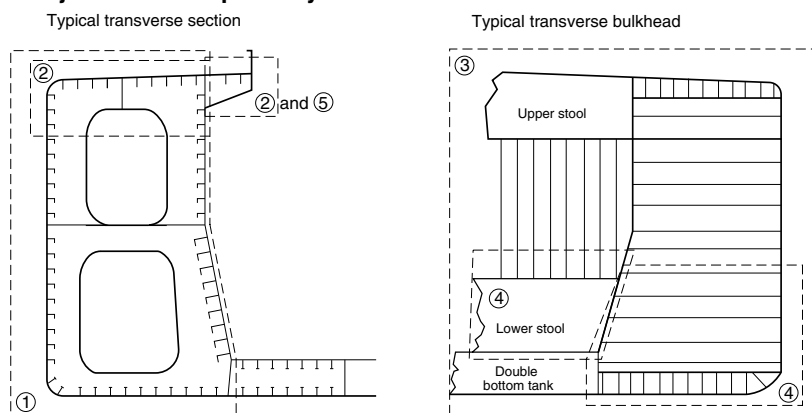
Figure 1 : Areas subject to close-up surveys and thickness measurements - Single hull oil tanker

Figure 2 : Areas subject to close-up surveys and thickness measurements - Combination carrier / OOC

6.2.3 The following is an indicative list of items that are to be addressed in the meeting:

- schedule of the ship (i.e. the voyage, docking and undocking manoeuvres, periods alongside, cargo and ballast operations, etc.)
- provisions and arrangements for thickness measurements (i.e. access, cleaning/de-scaling, illumination, ventilation, personal safety)
- extent of the thickness measurements
- acceptance criteria (refer to the list of minimum thicknesses)
- extent of close-up survey and thickness measurements considering the coating condition and suspect areas/areas of substantial corrosion
- execution of thickness measurements
- taking representative readings in general and where uneven corrosion/pitting is found
- mapping of areas of substantial corrosion, and
- communication between attending surveyor(s), the thickness measurement firm operator(s) and owner representative(s) concerning findings.

6.3 Scope of survey

6.3.1 In addition to the requirements of annual surveys, the class renewal survey is to include examination, tests and checks of sufficient extent to ensure that the hull and related piping are in satisfactory condition for the new period of class to be assigned, subject to proper maintenance and operation and to periodical surveys being carried out at the due dates.

6.3.2 All cargo tanks, ballast tanks, including double bottom tanks, pump rooms, pipe tunnels, cofferdams and void spaces bounding cargo tanks, decks and outer hull are to be examined, and this examination is to be supplemented by thickness measurement and testing as required in [6.5] and [6.6], to ensure that the structural integrity remains effective. The aim of the examination is to discover substantial corrosion, significant deformation, fractures, damages or other structural deterioration, that may be present.

6.3.3 As indicated in Ch 3, Sec 3, [2.1.1], a bottom survey in dry condition is to be a part of the class renewal survey. The overall and close-up surveys and thickness measure-

ments, as applicable, of the lower portions of the cargo tanks and ballast tanks are to be carried out during this bottom survey in accordance with the applicable requirements for class renewal surveys, if not already performed.

Lower portions of the cargo and ballast tanks are considered to be the parts below light ballast water line.

6.3.4 Where provided, the condition of the corrosion prevention system of cargo tanks is to be examined.

A ballast tank is to be examined at subsequent annual surveys where:

- a hard protective coating has not been applied from the time of construction, or
- a soft or semi-hard coating has been applied, or
- substantial corrosion is found within the tank, or
- the hard protective coating is found to be in less than good condition and the hard protective coating is not repaired to the satisfaction of the Surveyor.

Thickness measurement is to be carried out as deemed necessary by the Surveyor.

6.4 Overall and close-up surveys

6.4.1 Each class renewal survey is to include an overall survey of all tanks and spaces.

6.4.2 The minimum requirements for close-up surveys are given in Tab 1 for single hull oil tankers and combination carriers or Tab 2 for double hull oil tankers.

6.4.3 The Surveyor may extend the close-up survey as deemed necessary, taking into account the maintenance of the tanks under survey, the condition of the corrosion prevention system and also in the following cases:

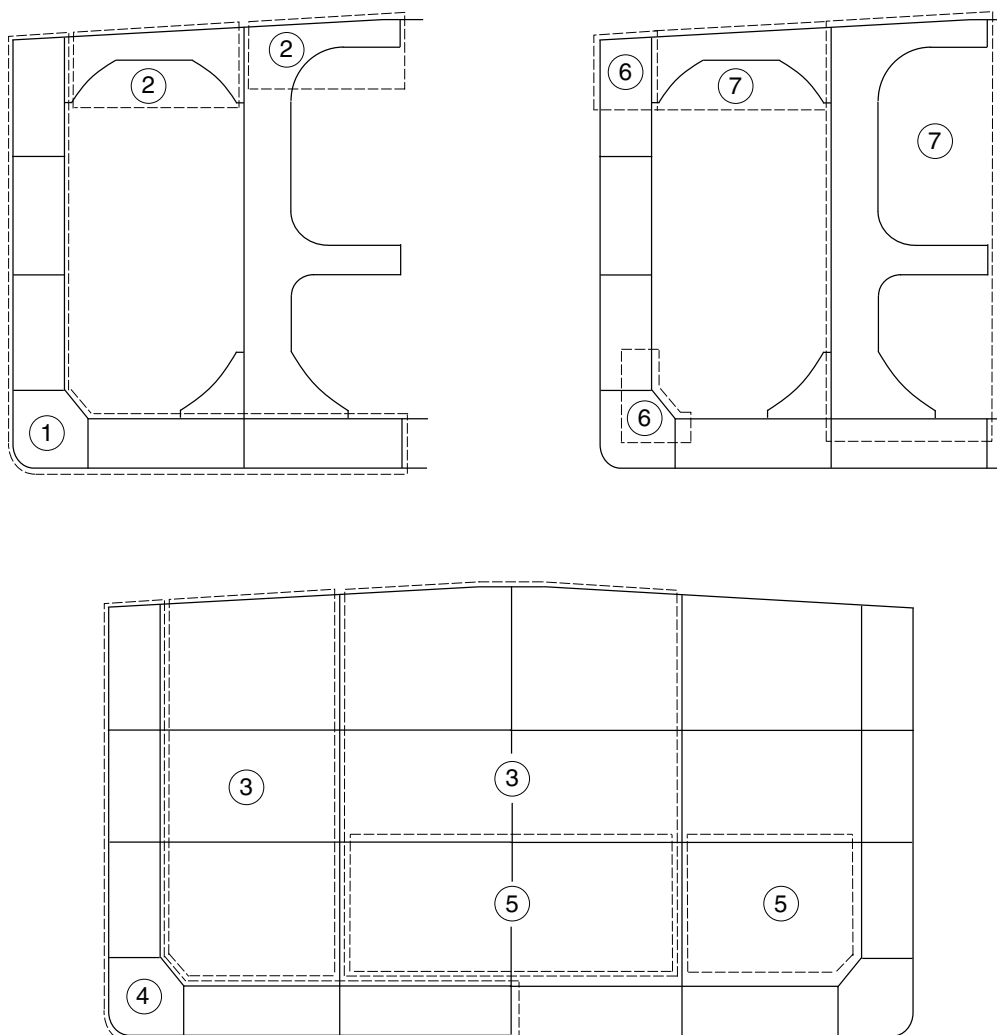
- where tanks have structural arrangements or details which have suffered defects in similar tanks or on similar ships according to available information
- where tanks have structures approved with reduced scantlings.

6.4.4 For areas in tanks where hard protective coatings are found to be in good condition, as defined in Ch 2, Sec 2, [2.2.14], the extent of close-up surveys required according to Tab 1 or Tab 2 may be specially considered.

Table 2 : Close-up survey at class renewal survey of double hull oil tankers

Age of ship (in years at time of class renewal survey)			
Class renewal survey No.1 age ≤ 5	Class renewal survey No.2 5 < age ≤ 10	Class renewal survey No.3 10 < age ≤ 15	Class renewal survey No.4 and subsequent age > 15
One web frame ① in a ballast tank (1)	All web frames ① in a ballast tank (1) The knuckle area ⑥ and the upper part (5 meters approximately) of one web frame in each remaining ballast tank	All web frames ① in all ballast tanks	As class renewal survey for ships between 10 and 15 years of age Additional transverse areas as deemed necessary by the Society
One deck transverse ② in a cargo tank	One deck transverse ② in two cargo tanks	All web frames ⑦ including deck transverse and cross ties, if fitted, in a cargo tank One web frame ⑦ including deck transverse and cross ties, if fitted, in each remaining cargo tank	
One transverse bulkhead ④ in a ballast tank (1)	One transverse bulkhead ④ in each ballast tank (1)	All transverse bulkheads in all cargo ③ and ballast tanks ④	
One transverse bulkhead ⑤ in a cargo wing tank (2) One transverse bulkhead ⑤ in a cargo centre tank	One transverse bulkhead ⑤ in a cargo wing tank (2) One transverse bulkhead ⑤ in two cargo centre tanks		
<p>(1) Ballast tank: apart from the fore and aft peak tanks, the term “ballast tank” has the following meaning:</p> <ul style="list-style-type: none"> all ballast compartments (hopper tank, side tank and double-deck tank, if separate from double-bottom tank) located on one side, i.e. portside or starboard side, and additionally double-bottom tank on portside plus starboard side, when the longitudinal central girder is not watertight and, therefore, the double-bottom tank is a unique compartment from portside to starboard side; or all ballast compartments (double-bottom tank, hopper tank, side tank and double-deck tank) located on one side, i.e. portside or starboard side, when the longitudinal central girder is watertight and, therefore, the portside double-bottom tank separate from the starboard side double-bottom tank. <p>(2) Where no centre cargo tank is fitted (as in the case of centre longitudinal bulkhead), transverse bulkheads in wing tanks are to be surveyed.</p> <p>Note 1: ①, ②, ③, ④, ⑤, ⑥ and ⑦ are areas to be subjected to close-up surveys and thickness measurements (see Fig 3).</p> <p>① Web frame in a ballast tank means vertical web in side tank, hopper web in hopper tank, floor in double bottom tank and deck transverse in double deck tank (where fitted), including adjacent structural members. In fore and aft peak tank, web frame means a complete transverse web frame ring including adjacent structural members.</p> <p>② Deck transverse including adjacent deck structural members (or external structure on deck in way of the tank, where applicable).</p> <p>③ Transverse bulkhead complete in cargo tanks, including girder system adjacent structural members (such as longitudinal bulkheads) and internal structure of lower and upper stools, where fitted.</p> <p>④ Transverse bulkhead complete in ballast tanks, including girder system and adjacent structural members, such as longitudinal bulkheads, girders in double bottom tanks, inner bottom plating, hopper side, inner hull longitudinal bulkhead, connecting brackets.</p> <p>⑤ Transverse bulkhead lower part in cargo tank, including girder system, adjacent structural members (such as longitudinal bulkheads) and internal structure of lower stool where fitted.</p> <p>⑥ Knuckle area is the area of the web frame around the connections of the slope hopper plating to the inner hull bulkhead and the inner bottom plating, up to 2 meters from the corners both on the bulkhead and the double bottom.</p> <p>⑦ Web frame in a cargo tank means deck transverse, longitudinal bulkhead structural elements and cross ties, where fitted, including adjacent structural members.</p>			

Figure 3 : Areas subject to close-up surveys and thickness measurements - Double hull oil tanker



6.5 Thickness measurements

6.5.1 The minimum requirements for thickness measurements at class renewal survey are given in Tab 3.

6.5.2 Provisions for extended measurements for areas with substantial corrosion are given in Tab 4 for single hull oil tankers and combination carriers or Tab 5 for double hull oil tankers and as may be additionally specified in the survey program as required in [6.1]. These extended thickness measurements are to be carried out before the survey is credited as completed.

Suspect areas identified at previous surveys are to be examined.

Areas of substantial corrosion identified at previous surveys are to have thickness measurements taken.

The Surveyor may further extend the thickness measurements as deemed necessary.

Note 1: For ships built under the Common Structural Rules, the identified substantial corrosion areas are required to be examined and additional thickness measurements are to be carried out at annual and intermediate surveys.

6.5.3 When pitting is found on bottom plating and its intensity is 20% or more, thickness measurements are to be extended in order to determine the actual plate thickness out of the pits and the depth of the pits. Where the wastage is in the substantial corrosion range or the average depth of pitting is 1/3 or more of the actual plate thickness, the pitted plate is to be considered as a substantially corroded area.

6.5.4 For areas in tanks where hard protective coatings are found to be in good condition as defined in Ch 2, Sec 2, [2.2.14], the extent of thickness measurements according to Tab 3 may be specially considered.

6.5.5 On oil tankers of 130 m in length and upwards (as defined in the International Convention on Load Lines in force) and more than 10 years of age, the longitudinal strength of the ship's hull girder is to be evaluated in compliance with the requirements of Ch 4, App 1 on the basis of the thickness of the structures measured, renewed or reinforced, as appropriate, during the class renewal survey.

Table 3 : Thickness measurements at class renewal survey of oil tankers and combination carriers

Age of ship (in years at time of class renewal survey)			
Class renewal survey No.1 age ≤ 5	Class renewal survey No.2 5 < age ≤ 10	Class renewal survey No.3 10 < age ≤ 15	Class renewal survey No.4 and subsequent age > 15
Suspect areas	Suspect areas	Suspect areas	Suspect areas
One section of deck plating for the full beam of the ship within the cargo area (in way of a ballast tank, if any, or a cargo tank used primarily for water ballast)	Within the cargo area: <ul style="list-style-type: none"> • each deck plate (1) • 1 transverse section (2) 	Within the cargo area: <ul style="list-style-type: none"> • each deck plate (1) • 2 transverse sections (2) (3) • all wind and water strakes 	Within the cargo area: <ul style="list-style-type: none"> • each deck plate (1) • 3 transverse sections (2) (3) • each bottom plate
Measurements, for general assessment and recording of corrosion pattern, of those structural members subject to close-up survey according to Tab 1 and Tab 2	Measurements, for general assessment and recording of corrosion pattern, of those structural members subject to close-up survey according to Tab 1 and Tab 2	Measurements, for general assessment and recording of corrosion pattern, of those structural members subject to close-up survey according to Tab 1 and Tab 2	Measurements, for general assessment and recording of corrosion pattern, of those structural members subject to close-up survey according to Tab 1 and Tab 2
	Selected wind and water strakes outside the cargo area	Selected wind and water strakes outside the cargo area	All wind and water strakes, full length
<p>(1) For combination carriers only the deck plating outside line of cargo hold hatch openings is to be measured.</p> <p>(2) Transverse sections are to be chosen where the largest reductions are likely to occur or as revealed by deck plating measurements.</p> <p>(3) At least one section is to be within 0,5 L amidships and, where applicable, in way of a ballast tank.</p>			

**Table 4 : Extended thickness measurements at those areas of substantial corrosion
Single hull oil tankers and combination carriers**

BOTTOM STRUCTURE		
Structural member	Extent of measurement	Pattern of measurement
Bottom plating	Minimum of 3 bays across tank, including aft bay Measurements around and under all suction bell mouths	5-point pattern for each panel between longitudinal and webs
Bottom longitudinals	Minimum of 3 longitudinals in each bay where bottom plating measured	3 measurements in line across flange and 3 measurements on vertical web
Bottom girders and brackets	At fore and aft transverse bulkhead, bracket toes and in centre of tanks	Vertical line of single measurements on web plating with one measurement between each panel stiffener, or a minimum of 3 measurements. 2 measurements across face flat. 5-point pattern on girder/bulkhead brackets.
Bottom transverse webs	3 webs in bays where bottom plating measured, with measurements at both ends and middle	5-point pattern over 2 square metre area. Single measurements on face flat.
Panel stiffening	Where provided	Single measurements

DECK STRUCTURE		
Structural member	Extent of measurement	Pattern of measurement
Deck plating	2 bands across tank	Minimum of 3 measurements per plate per band
Deck longitudinals	Minimum of 3 longitudinals in each of 2 bays	3 measurements in line vertically on webs and 2 measurements on flange (if fitted)
Deck girders and brackets	At fore and aft transverse bulkhead, bracket toes and in centre of tanks	Vertical line of single measurements on web plating with one measurement between each panel stiffener, or a minimum of 3 measurements. 2 measurements across face flat. 5-point pattern on girder/bulkhead brackets.
Deck transverse webs	Minimum of 2 webs, with measurements at both ends and middle of span	5-point pattern over 2 square metre area. Single measurements on face flat.
Panel stiffening	Where provided	Single measurements
SIDE SHELL AND LONGITUDINAL BULKHEADS		
Structural member	Extent of measurement	Pattern of measurement
Deckhead and bottom strakes and strakes in way of stringer platforms	Plating between each pair of longitudinals in a minimum of 3 bays	Single measurement
All other strakes	Plating between every third pair of longitudinals in same 3 bays	Single measurement
Longitudinals on deckhead and bottom strakes	Each longitudinal in same 3 bays	3 measurements across web and 1 measurement on flange
All other longitudinals	Every third longitudinal in same 3 bays	3 measurements across web and 1 measurement on flange
Longitudinal brackets	Minimum of 3 at top, middle and bottom of tank in same 3 bays	5-point pattern over area of bracket
Web frames and cross ties	3 webs with minimum of 3 locations on each web, including in way of cross tie connections	5-point pattern over approximately 2 square metre area, plus single measurements on web frame and cross tie face flats
TRANSVERSE BULKHEADS AND SWASH BULKHEADS		
Structural member	Extent of measurement	Pattern of measurement
Deckhead and bottom strakes, and strakes in way of stringer platforms	Plating between pair of stiffeners at 3 locations: approximately 1/4, 1/2 and 3/4 width of tank	5-point pattern between stiffeners over 1 metre length
All other strakes	Plating between pair of stiffeners at middle location	Single measurement
Strakes in corrugated bulkheads	Plating for each change of scantling at centre of panel and at flange of fabricated connection	5-point pattern over about 1 square metre of plating
Stiffeners	Minimum of 3 typical stiffeners	For web, 5-point pattern over span between bracket connections (2 measurements across web at each bracket connection and one at centre of span). For flange, single measurements at each bracket toe and at centre of span
Brackets	Minimum of 3 at top, middle and bottom of tank	5-point pattern over area of bracket
Deep webs and girders	Measurements at toe of bracket and at centre of span	For web, 5-point pattern over about 1 square metre 3 measurements across face flat
Stringer platforms	All stringers with measurements at both ends and middle	5-point pattern over 1 square metre of area plus single measurements near bracket toes and on face flats

**Table 5 : Extended thickness measurements at those areas of substantial corrosion
Double hull oil tankers**

BOTTOM, INNER BOTTOM AND HOPPER STRUCTURE		
Structural member	Extent of measurement	Pattern of measurement
Bottom, inner bottom and hopper structure plating	Minimum of 3 bays across double bottom tank, including aft bay Measurements around and under all suction bell mouths	5-point pattern for each panel between longitudinals and floors
Bottom, inner bottom and hopper structure longitudinals	Minimum of 3 longitudinals in each bay where bottom plating measured	3 measurements in line across flange and 3 measurements on vertical web
Bottom girders, including the watertight ones	At fore and aft watertight floors and in centre of tanks	Vertical line of single measurements on girder plating with one measurement between each panel stiffener, or a minimum of 3 measurements
Bottom floors, including the watertight ones	3 floors in bays where bottom plating measured, with measurements at both ends and middle	5-point pattern over 2 square metre area
Hopper structure web frame ring	3 floors in bays where bottom plating measured	5-point pattern over about 1 square metre of plating. Single measurements on flange.
Hopper structure transverse watertight bulkhead or swash bulkhead	• lower 1/3 of bulkhead	5-point pattern over about 1 square metre of plating
	• upper 2/3 of bulkhead	5-point pattern over 2 square metre of plating
	• stiffeners (minimum of 3)	For web, 5-point pattern over span (2 measurements across web at each end and one at centre of span). For flange, single measurements at each end and centre of span.
Panel stiffening	Where provided	Single measurements
DECK STRUCTURE		
Structural member	Extent of measurement	Pattern of measurement
Deck plating	2 transverse bands across tank	Minimum of 3 measurements per plate per band
Deck longitudinals	Every third longitudinal in each of 2 bands with a minimum of one longitudinal	3 measurements in line vertically on webs and 2 measurements on flange (if fitted)
Deck girders and brackets (usually in cargo tanks only)	At fore and aft transverse bulkhead, bracket toes and in centre of tanks	Vertical line of single measurements on web plating with one measurement between each panel stiffener, or a minimum of 3 measurements. 2 measurements across flange. 5-point pattern on girder/bulkhead brackets.
Deck transverse webs	Minimum of 2 webs, with measurements at both ends and middle of span	5-point pattern over 1 square metre area. Single measurements on flange.
Vertical web and transverse bulkhead in wing ballast tank (2 metres from deck)	Minimum of 2 webs, and both transverse bulkheads	5-point pattern over 1 square metre area
Panel stiffening	Where provided	Single measurements

STRUCTURE IN WING BALLAST TANKS		
Structural member	Extent of measurement	Pattern of measurement
Side shell and longitudinal bulkhead plating: <ul style="list-style-type: none"> • upper strake and strakes in way of horizontal girders • all other strakes 	Plating between each pair of longitudinals in a minimum of 3 bays (along the tank) Plating between every third pair of longitudinals in same 3 bays	Single measurement Single measurement
Side shell and longitudinal bulkhead longitudinals on: <ul style="list-style-type: none"> • upper strake • all other strakes 	Each longitudinal in same 3 bays Every third longitudinal in same 3 bays	3 measurements across web and 1 measurement on flange 3 measurements across web and 1 measurement on flange
Longitudinal brackets	Minimum of 3 at top, middle and bottom of tank in same 3 bays	5-point pattern over area of bracket
Vertical web and transverse bulkheads (excluding deckhead area): <ul style="list-style-type: none"> • strakes in way of horizontal girders • other strakes 	Minimum of 2 webs and both transverse bulkheads Minimum of 2 webs and both transverse bulkheads	5-point pattern over 2 square metre area 2 measurements between each pair of vertical stiffeners
Horizontal girders	Plating on each girder in a minimum of 3 bays	2 measurements between each pair of longitudinal girder stiffeners
Panel stiffening	Where provided	Single measurements
LONGITUDINAL BULKHEADS IN CARGO TANKS		
Structural member	Extent of measurement	Pattern of measurement
Deckhead and bottom strakes and strakes in way of the horizontal stringers of transverse bulkheads	Plating between each pair of longitudinals in a minimum of 3 bays	Single measurement
All other strakes	Plating between every third pair of longitudinals in same 3 bays	Single measurement
Longitudinals on deckhead and bottom strakes	Each longitudinal in same 3 bays	3 measurements across web and 1 measurement on flange
All other longitudinals	Every third longitudinal in same 3 bays	3 measurements across web and 1 measurement on flange
Longitudinal brackets	Minimum of 3 at top, middle and bottom of tank in same 3 bays	5-point pattern over area of bracket
Web frames and cross ties	3 webs with minimum of 3 locations on each web, including in way of cross tie connections	5-point pattern over approximately 2 square metre area of webs, plus single measurements on flanges of web frame and cross ties
Lower end brackets (opposite side of web frame)	Minimum of 3 brackets	5-point pattern over approximately 2 square metre area of brackets, plus single measurements on bracket flanges

TRANSVERSE WATERTIGHT AND SWASH BULKHEADS IN CARGO TANKS		
Structural member	Extent of measurement	Pattern of measurement
Upper and lower stool, where fitted	<ul style="list-style-type: none"> Transverse band within 25mm of welded connection to inner bottom/deck plating Transverse band within 25mm of welded connection to shelf plate 	5-point pattern between stiffeners over 1 metre length
Deckhead and bottom strakes, and strakes in way of horizontal stringers	Plating between pair of stiffeners at 3 locations: approximately 1/4, 1/2 and 3/4 width of tank	5-point pattern between stiffeners over 1 metre length
All other strakes	Plating between pair of stiffeners at middle location	Single measurement
Strakes in corrugated bulkheads	Plating for each change of scantling at centre of panel and at flange of fabricated connection	5-point pattern over about 1 square metre of plating
Stiffeners	Minimum of 3 typical stiffeners	For web, 5-point pattern over span between bracket connections (2 measurements across web at each bracket connection and one at centre of span). For flange, single measurements at each bracket toe and at centre of span
Brackets	Minimum of 3 at top, middle and bottom of tank	5-point pattern over area of bracket
Horizontal stringers	All stringers with measurements at both ends and middle	5-point pattern over 1 square metre of area plus single measurements near bracket toes and on flange

6.6 Tank testing

6.6.1 The requirements for tank testing at class renewal survey are given in Tab 6.

6.6.2 Cargo tank testing carried out by the ship's crew under the direction of the Master may be accepted by the Surveyor, provided the following conditions are complied with:

- a tank testing procedure, specifying fill heights, tanks being filled and bulkheads being tested, has been submitted by the Owner and reviewed by the Society prior to the testing being carried out
- there is no record of leakage, distortion or substantial corrosion that would affect the structural integrity of the tank
- the tank testing has been satisfactorily carried out, within the class renewal survey window, not more than 3 months prior to the date of the survey on which the overall or close-up survey is completed

d) the satisfactory results of the testing is recorded in the ship's logbook

e) the internal and external conditions of the tanks and associated structures are found satisfactory by the Surveyor at the time of the overall and close-up surveys.

6.6.3 The Surveyor may extend the tank testing as deemed necessary.

6.6.4 Boundaries of ballast tanks are to be tested with a head of liquid to the top of air pipes.

Boundaries of cargo tanks are to be tested to the highest point that liquid will rise under service conditions

For double hull oil tankers, the testing of double bottom tanks and other spaces not designed for the carriage of liquid may be omitted, provided a satisfactory internal examination together with an examination of the tanktop is carried out.

Table 6 : Tank testing at class renewal survey of oil tankers and combination carriers

Age of ship (in years at time of class renewal survey)	
Class renewal survey No.1 age ≤ 5	Class renewal survey No.2 and subsequent age > 5
All ballast tank boundaries	All ballast tank boundaries
Cargo tank boundaries facing ballast tanks, void spaces, pipe tunnels, pump rooms or cofferdams	All cargo tank bulkheads

6.7 Cargo piping, area and pump rooms

6.7.1 Cargo and crude oil washing piping on deck and cargo and ballast piping systems within the cargo area are to be examined and operationally tested to working pressure to the attending Surveyor's satisfaction to ensure that their tightness and condition remain satisfactory. Special attention is to be given to any ballast piping in cargo tanks and cargo piping in ballast tanks and void spaces. Surveyors are to be advised on all occasions when this piping, including valves and fittings, is opened during repair periods and can be examined internally.

The surveyor may require dismantling and/or thickness measurements of piping. A hydraulic test is to be carried out in the event of repair or dismantling or cargo, crude oil washing, or ballast piping, or where doubts arise.

6.7.2 All safety valves on cargo piping and of cargo tanks are to be dismantled for examination, adjusted and, as applicable, resealed.

6.7.3 All cargo pump room boundaries are to be generally examined. All gas-tight shaft sealing devices are to be examined. The bottom of cargo pump rooms is to be presented clean for the examination of stripping devices and gutters.

6.8 Emergency towing arrangement

6.8.1 The survey is to include:

- an examination of the emergency towing arrangement
- confirmation that the arrangement is readily available with aft towing arrangement pre-rigged and forward chafing gear secured to the strong-point
- an examination of the pick-up gear, towing pennant and chafing gear over the full length for possible deterioration. Where the pennant line is stored in a watertight condition and can be confirmed as being maintained, consideration may be given to waiving the requirement to examine the pennant line over the full length
- an examination of the strong-points, fairleads and pedestal roller together with their attachments to the hull structure.

7 Class renewal survey - Cargo machinery items

7.1 Cargo area and cargo pump rooms

7.1.1 Ballast and stripping pumps are to be internally examined and prime movers checked. A working test is to be carried out, as far as practicable.

Maintenance records of cargo pumps are to be made available to the Surveyor.

7.1.2 Where a crude oil washing system is fitted, piping, pumps, valves and deck-mounted washing machines are to be examined and tested for signs of leakage, and anchoring devices of deck-mounted washing machines are to be checked to the Surveyor's satisfaction.

7.1.3 The satisfactory condition of the cargo heating system is to be verified and, if deemed necessary by the Surveyor, the system is to be pressure tested.

7.1.4 An operating test of the remote control of pumps and valves and of automatic closing valves is to be carried out.

7.1.5 A general examination of the electrical equipment and cables in dangerous zones such as cargo pump rooms and areas adjacent to cargo tanks is to be carried out for defective and non-certified safe type electrical equipment and fixtures, non-approved lighting and fixtures, and improperly installed or defective or dead-end wiring.

The electrical insulation resistance of the electrical equipment and circuits terminating in or passing through the dangerous zones is to be tested; however, in cases where a proper record of testing is maintained, consideration may be given to accepting recent test readings effected by the ship's personnel.

7.2 Fire-fighting systems in cargo area

7.2.1 The survey is to include the examination of fire-fighting systems of any type fitted on board for the protection of the cargo area, cargo pump room and other dangerous spaces, such as deck foam, water-spraying systems, etc., as applicable in accordance with the relevant requirements given in Ch 3, Sec 3, [3.8].

7.3 Inert gas system

7.3.1 In addition to the inspections required at the intermediate survey, the following is to be carried out:

- a) an internal examination of:
 - the inert gas generator, where fitted
 - the scrubber
 - the deck water seal including the non-return valve
 - the pressure/vacuum breaking device
 - the cooling water systems including overboard discharge from the scrubber
 - all valves
- b) a test to verify the proper operation of the system upon completion of all survey checks.

SECTION 4 CHEMICAL TANKERS

1 General

1.1 Application

1.1.1 The requirements of this Section apply to all self-propelled ships which have been assigned the service notation **chemical tanker ESP**. If such a ship is constructed with both integral and independent tanks, these requirements are applicable only to that portion of the cargo length containing integral tanks. Combined gas carriers/chemical tankers with independent tanks within the hull are to be surveyed as gas carriers.

1.1.2 The requirements apply to the surveys of the hull structure and piping systems in way of cargo tanks, pump rooms, cofferdams, pipe tunnels and void spaces within the cargo area and all ballast tanks. These requirements, however, do not apply to independent tanks on deck. They are additional to the requirements applicable to the remainder of the ship, given in Part A, Chapter 3 according to the relevant surveys.

1.1.3 The requirements contain the minimum extent of examination, thickness measurements and tank testing. When substantial corrosion and/or structural defects are found, the survey is to be extended and is to include additional close-up surveys when necessary.

1.1.4 In any kind of survey, i.e. class renewal, intermediate, annual or other surveys having the same scope, thickness measurements, when required by Tab 3, of structures in areas where close-up surveys are required are to be carried out simultaneously with close-up surveys.

1.1.5 Consideration may be given by the attending Surveyor to allow use of Remote Inspection Techniques (RIT) as an alternative to close-up survey, as defined in Ch 2, Sec 2. Surveys conducted using a RIT are to be completed to the satisfaction of the attending Surveyor.

1.1.6 In all cases the extent of the thickness measurements are to be sufficient as to represent the actual average condition.

1.1.7 When, in any survey, thickness measurements are required:

- the procedure detailed in Ch 2, Sec 2, [2.3] is to be applied
- the thickness measurement firm is to be part of the survey planning meeting to be held prior to commencing the survey.

1.1.8 The requirements for machinery surveys apply to surveys of the machinery and equipment in the cargo area or dedicated to cargo service systems and are additional to those given in Part A, Chapter 3 for all ships.

1.2 Documentation on board

1.2.1 The Owner is to obtain, supply and maintain documentation on board as specified in [1.2.2] and [1.2.3], which is to be readily available for examination by the Surveyor. The documentation is to be kept on board for the lifetime of the ship.

1.2.2 A survey report file is to be a part of the documentation on board consisting of:

- reports of structural surveys
- hull condition evaluation report (summarising the results of class renewal surveys)
- thickness measurement reports.

The survey report file is also to be available in the Owner's management office.

1.2.3 The following additional supporting documentation is to be available on board:

- survey program, as required in [6.1], until such time as the class renewal survey or intermediate survey, as applicable, has been completed
- main structural plans of cargo and ballast tanks
- previous repair history
- cargo and ballast history
- extent of use of inert gas system and tank cleaning procedures
- ship's personnel reports on:
 - structural deterioration/defects in general
 - leakage in bulkheads and piping systems
 - condition of coatings or corrosion prevention systems, if any
- any other information that may help identify critical structural areas and/or suspect areas requiring inspection.

1.2.4 Prior to survey, the Surveyor examines the documentation on board and its contents, which are used as a basis for the survey.

1.3 Reporting and evaluation of surveys

1.3.1 The data and information on the structural condition of the ship collected during survey are evaluated for acceptability and structural integrity of the ship's cargo area.

1.3.2 A hull condition evaluation report (summarising the results of class renewal surveys) is issued by the Society to the Owner, who is to place it on board the ship for reference at future surveys. The hull condition evaluation report is endorsed by the Society.

1.3.3 When a survey is split between different survey stations, a report is to be made for each portion of the survey. A list of items examined and/or tested (pressure testing, thickness measurements, etc.) and an indication of whether the item has been credited, are to be made available to the next attending Surveyor(s), prior to continuing or completing the survey.

1.4 Conditions for survey

1.4.1 In order to enable the attending surveyors to carry out the survey, provisions for proper and safe access are to be agreed between the Owner and the Society.

Details of the means of access are to be provided in the survey planning questionnaire.

In cases where the provisions of safety and required access are judged by the attending surveyors not to be adequate, the survey of the spaces involved is to not proceed.

1.5 Access to structures

1.5.1 For overall survey, means are to be provided to enable the surveyor to examine the hull structure in a safe and practical way.

1.5.2 For close-up survey, one or more of the following means for access, acceptable to the Surveyor, is to be provided:

- permanent staging and passages through structures
- temporary staging and passages through structures
- hydraulic arm vehicles such as conventional cherry pickers, lifts and movable platforms
- boats or rafts
- portable ladders
- other equivalent means.

1.5.3 For surveys conducted by use of remote inspection technique, one or more of the following means for access, acceptable to the Surveyor, is to be provided:

- unmanned robot arm
- remote operated vehicle (ROV)
- unmanned aerial vehicles/drones
- other means acceptable to the Society.

2 Annual survey - Hull items

2.1 General

2.1.1 The survey is to consist of an examination for the purpose of ensuring, as far as practicable, that the hull and piping are maintained in a satisfactory condition and should take into account the service history, condition and extent of the corrosion prevention system of ballast tanks and areas identified in the survey report file.

2.2 Weather decks

2.2.1 The survey is to include:

- examination of cargo tank openings, including gaskets, covers, coamings and flame screens

- examination of cargo tank vent system, including the pressure/vacuum valves and secondary means to prevent over- or under-pressure and devices to prevent the passage of flames
- examination of flame screens on vents to all bunker tanks
- examination of cargo, bunker, ballast and vent piping systems, including remote control valves, safety valves and various safety devices, as well as vent masts and headers
- confirmation that wheelhouse doors and windows, sidescuttles and windows in superstructure and deckhouse ends facing the cargo area are in satisfactory condition
- confirmation that pumps, valves and pipelines are identified and distinctively marked.
- examination of watertight penetrations as far as practicable.

2.3 Cargo pump rooms and pipe tunnels

2.3.1 The survey is to include:

- examination of all pump room bulkheads and pipe tunnels (if any) for signs of chemical cargo leakage or fractures and, in particular, the sealing arrangements of penetrations in pump room bulkheads
- examination of the condition of all piping systems, in cargo pump rooms and pipe tunnels (if any)
- examination of the bilge and ballast arrangements and confirmation that pumps and pipelines are identified.

2.4 Ballast tanks

2.4.1 Ballast tanks are to be internally examined when required as a consequence of the results of the class renewal survey or the intermediate survey; see [6.3.4] and [4.2.2], respectively.

2.4.2 When considered necessary by the Surveyor or when extensive corrosion exists, thickness measurements are to be carried out and if the results of these thickness measurements indicate that substantial corrosion is found, the extent of thickness measurements is to be increased in accordance with Tab 4. These extended thickness measurements are to be carried out before the survey is credited as completed. Suspect areas identified at previous surveys are to be examined. Areas of substantial corrosion identified at previous surveys are to have thickness measurements taken.

2.5 Emergency towing arrangement

2.5.1 The Owner or his representative is to declare to the attending Surveyor that no significant alterations have been made, without prior approval from the Society, to the equipment and arrangements fitted on board in accordance with the provisions given in Pt B, Ch 9, Sec 4, [3].

2.5.2 The survey is to include:

- an examination, as far as practicable, of the emergency towing arrangement
- confirmation that the aft towing arrangement is prerigged and forward chafing gear is secured to the strong-point
- confirmation of the proper functioning of the light, where it is provided, on the pick-up gear marker buoy.

3 Annual survey - Cargo machinery items

3.1 Cargo area and cargo pump rooms

3.1.1 The Owner or his representative is to declare to the attending Surveyor that no modifications or alterations which might impair safety have been made to the various installations in dangerous zones without prior approval from the Society.

The survey is to include:

- confirmation that potential sources of ignition in or near the cargo pump rooms, such as loose gear, excessive product in bilge, excessive vapours, combustible materials, etc., are eliminated and that access ladders are in satisfactory condition
- examination, as far as practicable, of cargo, bilge, ballast and stripping pumps for excessive gland seal leakage, verification of proper operation of electrical and mechanical remote operating and shutdown devices and operation of the pump room bilge system, and checking that pump foundations are intact
- confirmation that the ventilation system, including portable equipment, if any, of all spaces in the cargo area (including cargo pump rooms) is operational, ducting is intact, dampers are operational and screens are clean
- confirmation that electrical equipment in dangerous zones, cargo pump rooms and other spaces is in satisfactory condition and has been properly maintained
- confirmation that the remote operation of the cargo pump room bilge system is satisfactory
- confirmation that cargo pump room rescue arrangements are in order
- confirmation that removable pipe lengths or other approved equipment necessary for cargo separation are available and in satisfactory condition
- examination of the cargo heating/cooling system and sampling arrangements where required
- examination of the cargo-transfer arrangement and confirmation that the ship's cargo hoses are suitable for their intended purpose and in satisfactory condition and, where appropriate, type approved or marked with date of testing
- confirmation that any special arrangement made for bow or stern loading/unloading is in satisfactory condition and test of the means of communications and the remote shutdown for the cargo pumps
- confirmation that, if applicable, the provisions made for chemical products which have special requirements as per Pt D, Ch 8, Sec 15 are satisfactory.

3.2 Instrumentation and safety devices

3.2.1 The survey is to include the following items, as far as required or fitted:

- confirmation that installed pressure gauges on cargo discharge lines are properly operational
- examination of gauging devices, high level alarms and valves associated with overflow control
- confirmation that devices provided for measuring the temperature of the cargo and associated alarms operate satisfactorily
- confirmation that the required gas detection instruments are on board and satisfactory arrangements have been made for the supply of any required vapour detection tubes.

3.3 Fire-fighting systems in cargo area

3.3.1 The survey is to include:

- external examination of piping and cut-out valves of fixed fire-fighting systems related to cargo tanks and cargo pump rooms
- confirmation, as far as practicable and when appropriate, that the remote means for closing the various openings are operable
- examination of the appropriate portable fire-extinguishing equipment for the chemical cargoes to be carried in accordance with the relevant requirements given in Ch 3, Sec 1, [3.4.3]
- examination of fire-fighting systems of any type fitted on board such as deck foam, water-spraying, etc. as applicable in accordance with the relevant requirements given in Ch 3, Sec 1, [3.4.2].

3.4 Inert gas system and inert/padding/drying gas

3.4.1 If an inert gas system such as that installed on board oil tankers is fitted, the requirements given in Ch 4, Sec 3, [3.4] are to be complied with.

3.4.2 If an inert gas system consisting of a gas container package is fitted, arrangements are to be made for sufficient inert or padding gas to be carried to compensate for normal losses and means are to be provided for monitoring of ullage spaces.

3.4.3 If drying gas is necessary to supply the cargo spaces, arrangements are to be made for sufficient drying gas to be carried to compensate for normal losses and means are to be provided for monitoring of ullage spaces.

3.4.4 When drying agents are used on air inlets to cargo tanks, it is to be verified that arrangements are made for sufficient medium to be carried.

4 Intermediate survey - Hull items

4.1 General

4.1.1 For weather decks, an examination as far as applicable of cargo, bunker, ballast, steam and vent piping systems as well as vent masts and headers is to be carried out. If upon examination, there is any doubt as to the condition of the piping, the piping may be required to be pressure tested, thickness measured or both.

The survey is also to include:

- confirmation that the pipelines and independent cargo tanks where applicable, are electrically bonded to the hull
- examination of vent line drainage arrangements.

4.2 Ships between 5 and 10 years of age

4.2.1 For ballast tanks, an overall survey of representative tanks selected by the Surveyor is to be carried out. If such inspection reveals no visible structural defects, the examination may be limited to a verification that the hard protective coating remains in good condition.

4.2.2 A ballast tank is to be examined at subsequent annual surveys where:

- a hard protective coating has not been applied from the time of construction, or
- a soft or semi-hard coating has been applied, or
- substantial corrosion is found within the tank, or
- the hard protective coating is found to be in less than good condition and the hard protective coating is not repaired to the satisfaction of the Surveyor.

4.2.3 In addition to the requirements above, suspect areas identified at previous surveys are to be examined.

4.3 Ships between 10 and 15 years of age

4.3.1 The scope of intermediate survey of ships between 10 and 15 years of age is the scope of the preceding class renewal survey of hull, as detailed in Article [6] with bottom survey in dry condition or bottom in water survey as applicable. However, pressure testing of all cargo and ballast tanks are not required unless deemed necessary by the attending Surveyor.

4.4 Ships over 15 years of age

4.4.1 The scope of intermediate survey of ships over 15 years of age is the scope of the preceding class renewal survey of hull, as detailed in [6] with bottom survey in dry condition, except that pressure testing of ballast and cargo tanks as detailed in [6.6] is not required unless deemed necessary by the Surveyor.

The overall and close-up surveys and thickness measurements, as applicable, of the lower portions of the cargo tanks and water ballast tanks are to be carried out during the bottom survey in accordance with the applicable requirements for intermediate surveys, if not already performed.

Lower portions of the cargo and ballast tanks are considered to be the parts below light ballast water line.

The requirements of [6.8] are not applicable.

5 Intermediate survey - Cargo machinery items

5.1 Cargo area and cargo pump rooms

5.1.1 A general examination of the electrical equipment and cables in dangerous zones such as cargo pump rooms and areas adjacent to cargo tanks is to be carried out for defective and non-certified safe type electrical equipment, non-approved lighting and fixtures, and improperly installed or defective or dead-end wiring.

5.1.2 The electrical insulation resistance of the electrical equipment and circuits terminating in or passing through the dangerous zones is to be tested; however, in cases where a proper record of testing is maintained, consideration may be given to accepting recent test readings effected by the ship's personnel.

5.1.3 The satisfactory condition of the cargo heating/cooling system is to be verified.

5.1.4 The spares for cargo area mechanical ventilation fans are to be available on board.

5.2 Inert gas system

5.2.1 If an inert gas system such as that installed on board oil tankers is fitted, the requirements given in Ch 4, Sec 3, [5.2] for intermediate survey of oil tankers are to be complied with.

5.2.2 For ships fitted with another type of inert gas producing system, the main parts such as the inert gas generator, deck water seal or equivalent back flow arrangement, segregation devices, as fitted are to be overhauled for examination and alarms are to be tested.

Inert gas producer isolating valves, when fitted, are to be dismantled for examination.

5.3 Personnel protection

5.3.1 The survey is to include:

- confirmation that the protective clothing for crew engaged in loading and discharging operations and its stowage is in satisfactory condition
- confirmation that the required safety equipment and associated breathing apparatus and associated air supplies and, when appropriate, emergency escape respiratory and eye protection are in a satisfactory condition and properly stowed
- confirmation that the medical first-aid equipment, including stretchers and oxygen resuscitation equipment are in a satisfactory condition
- confirmation that arrangements have been made for the antidotes for the cargoes actually carried to be on board

- confirmation that decontamination arrangements and eyewashes are operational
- confirmation that the required gas detection instruments are on board and that arrangements have been made for the supply of the appropriate vapour detection tubes
- confirmation that the arrangements for the stowage of cargo samples are satisfactory.

6 Class renewal survey - Hull items

6.1 Survey program and preparation for survey

6.1.1 The Owner in cooperation with Society is to work out a specific Survey Programme prior to the commencement of any part of:

- the class renewal survey
- the intermediate survey for chemical tankers over 10 years of age.

The survey programme is to be in a written format.

Prior to the development of the survey programme, the survey planning questionnaire is to be completed by the Owner, and forwarded to the Society.

The survey programme at intermediate survey may consist of the survey programme at the previous class renewal survey supplemented by the hull condition evaluation report of that class renewal survey and later relevant survey reports.

The survey program is to be worked out taking into account any amendments to the survey requirements after the last class renewal survey carried out.

6.1.2 In developing the Survey Programme, the following documentation is to be collected and consulted with a view to selecting tanks, areas, and structural elements to be examined:

- survey status and basic ship information
- documentation on board, as described in [1.2.2] and [1.2.3]
- main structural plans of cargo and ballast tanks (scantling drawings), including information on use of high tensile steels (HTS), clad steel and stainless steel
- hull condition evaluation report
- relevant previous damage and repair history
- relevant previous survey and inspection reports from both the Society and the Owner
- information regarding the use of the ship's tanks, typical cargoes and other relevant data
- details of the inert gas plant and tank cleaning procedures
- information and other relevant data regarding conversion or modification of the ship's cargo and ballast tanks since the time of construction
- description and history of the coating and the corrosion prevention system (previous class notations), if any

- inspections by the Owner's personnel during the last three years with reference to structural deterioration in general, leakages in tank boundaries and piping and condition of the coating and corrosion prevention system, if any
- information regarding the relevant maintenance level during operation including port state control reports of inspection containing hull related deficiencies, Safety Management System non-conformities relating to hull maintenance, including the associated corrective action(s); and
- any other information that will help identify suspect areas and critical structural areas.

6.1.3 The submitted Survey Programme is to account for and comply, as a minimum, with the requirements for close-up surveys, thickness measurements, tank testing and pipe testing given in Tab 1, Tab 2, Tab 3, [6.6] and [6.7.3], respectively and is to include relevant information including at least:

- basic ship information and particulars
- main structural plans (scantling drawings), including information on the use of high tensile steels (HTS), clad steel and stainless steel
- plan of tanks
- list of tanks with information on their use, corrosion prevention and condition of coating
- conditions for survey (e.g., information regarding tank cleaning, gas freeing, ventilation, lighting, etc.)
- provisions and methods for access to structures
- equipment for surveys
- nomination of tanks and areas for close-up surveys according to [6.4]
- nomination of sections and areas for thickness measurements according to [6.5]
- nomination of tanks for tank testing according to [6.6], and the pipes that are to undergo pipe testing according to [6.7.3]
- identification of the thickness measurement firm
- damage experience related to the ship in question
- critical structural areas and suspect areas, where relevant.

6.1.4 The survey program is also to include the maximum acceptable structural corrosion diminution levels applicable to the ship. The Society will advise the Owner of this information.

6.2 Survey planning meeting

6.2.1 Proper preparation and close co-operation between the attending surveyor(s) and the Owner's representatives onboard prior to and during the survey are an essential part in the safe and efficient conduct of the survey. During the survey on board safety meetings are to be held regularly.

Table 1 : Requirements for close-up survey at class renewal survey of single skin chemical tankers

Age of ship (in years at time of class renewal survey)			
Class renewal survey No.1 age ≤ 5	Class renewal survey No.2 5 < age ≤ 10	Class renewal survey No.3 10 < age ≤ 15	Class renewal survey No.4 and subsequent age > 15
One web frame ring ①: - in a ballast wing tank	All web frame rings ①: - in a ballast wing tank, or - in a double bottom ballast tank (1)	All web frame rings ①: - in all ballast tanks - in a cargo wing tank One web frame ring ①: - in each remaining cargo tank	As class renewal survey for ships between 10 and 15 years of age Additional transverse areas as deemed necessary by the Society
One deck transverse ②: - in a cargo tank or on deck	One deck transverse ②: - in each remaining ballast tank or on deck - in a cargo wing tank or on deck - in two cargo centre tanks or on deck		
	Both transverse bulkheads ③: - in a ballast wing tank	All transverse bulkheads ③: - in all cargo tanks - in all ballast tanks	
Lower part of one transverse bulkhead ④: - in a ballast tank - in a cargo wing tank - in a cargo centre tank (2)	Lower part of one transverse bulkhead ④: - in each remaining ballast tank - in two cargo centre tanks (2) - in a cargo wing tank		

(1) Ballast double hull tank means double bottom tank plus double side tank plus double deck tank, as applicable, even if these tanks are separate.
 (2) Where no centre cargo tanks are fitted (as in the case of centre longitudinal bulkhead), transverse bulkheads in wing tanks are to be surveyed.
Note 1: ①, ②, ③ and ④ are areas to be subjected to close-up surveys and thickness measurements (see Fig 1 and Fig 2):
 ① Complete transverse web frame ring, including adjacent structural members.
 ② Deck transverse, including adjacent deck structural members.
 ③ Transverse bulkhead complete, including girder system and adjacent structural members.
 ④ Transverse bulkhead lower part, including girder system and adjacent structural members.

Figure 1 : Representative transverse section of chemical tanker - Areas ① and ②

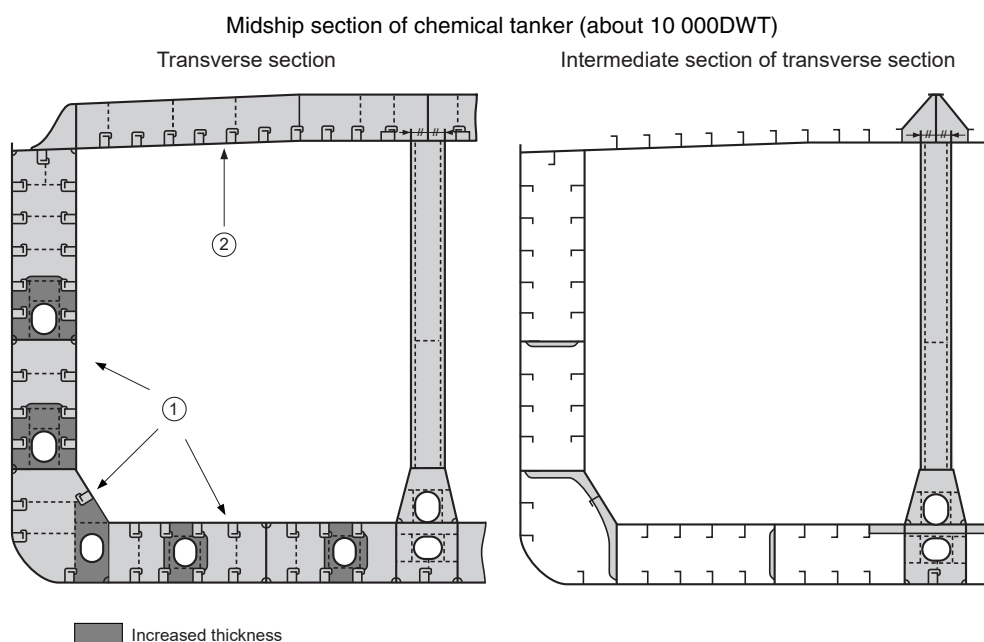
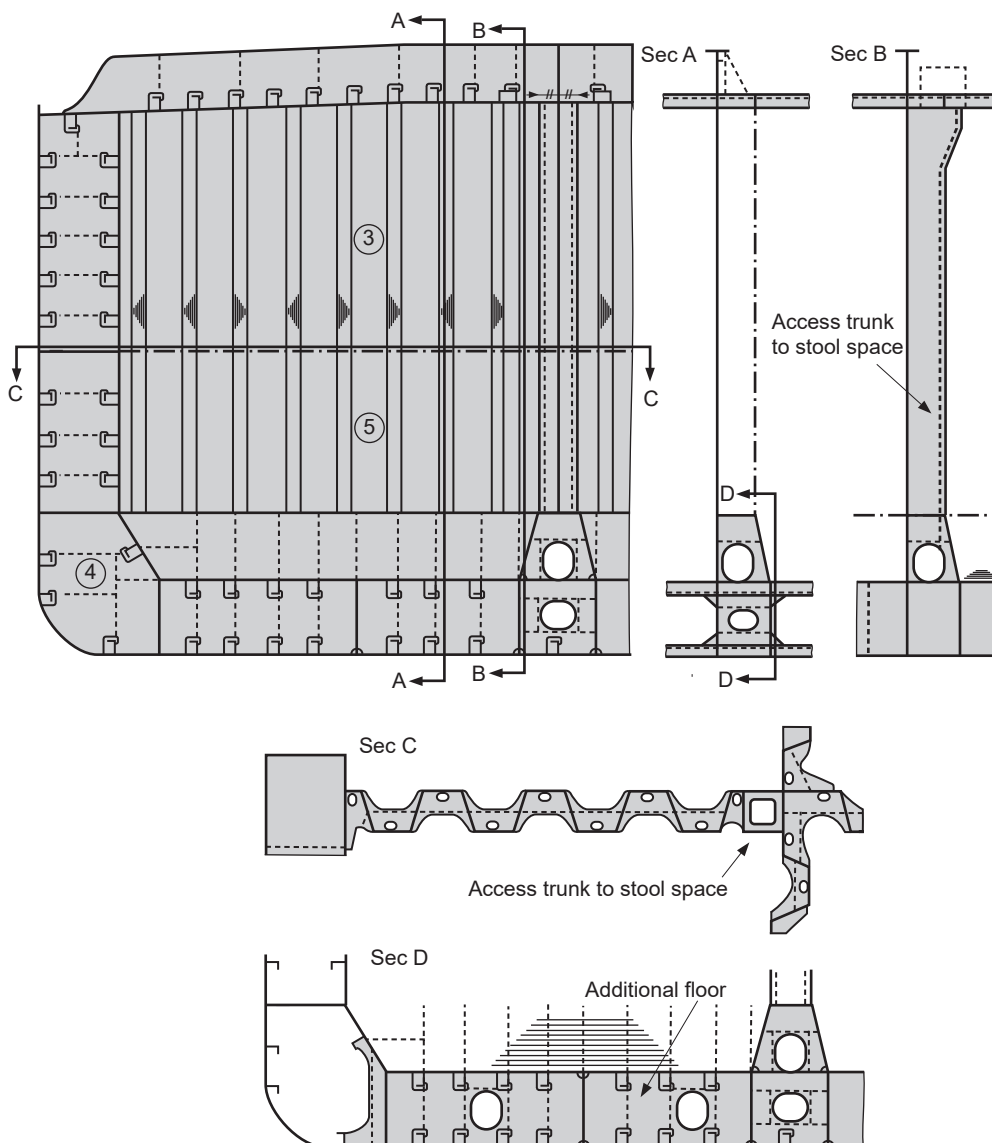


Figure 2 : Representative transverse section of chemical tanker - Areas ③, ④ and ⑤

Transverse bulkhead of chemical tanker (about 10 000DWT)



6.2.2 Prior to commencement of any part of the renewal and intermediate survey, a survey planning meeting is to be held between the attending surveyor(s), the owner's representative in attendance, the thickness measurement firm representative, where involved, and the master of the ship or an appropriately qualified representative appointed by the master or Company for the purpose to ascertain that all the arrangements envisaged in the survey programme are in place, so as to ensure the safe and efficient conduct of the survey work to be carried out. See also Ch 2, Sec 2, [2.3.2].

6.2.3 The following is an indicative list of items that are to be addressed in the meeting:

- schedule of the ship (i.e. the voyage, docking and undocking manoeuvres, periods alongside, cargo and ballast operations etc.)
- provisions and arrangements for thickness measurements (i.e. access, cleaning/descaling, illumination, ventilation, personal safety)
- extent of the thickness measurements
- acceptance criteria (refer to the list of minimum thicknesses)
- extent of close-up survey and thickness measurement considering the coating condition and suspect areas/areas of substantial corrosion
- execution of thickness measurements
- taking representative readings in general and where uneven corrosion/pitting is found
- mapping of areas of substantial corrosion; and
- communication between attending surveyor(s), the thickness measurement firm operator(s) and owner representative(s) concerning findings.

6.3 Scope of survey

6.3.1 In addition to the requirements of annual surveys, the class renewal survey is to include examination, tests and checks of sufficient extent to ensure that the hull and related piping are in satisfactory condition for the new period of class to be assigned, subject to proper maintenance and operation and to periodical surveys being carried out at the due dates.

6.3.2 All cargo tanks, ballast tanks, including double bottom tanks, pump rooms, pipe tunnels, cofferdams and void spaces bounding cargo tanks, decks and outer hull are to be examined, and this examination is to be supplemented by thickness measurement and testing as required in [6.5] and [6.6] to ensure that the structural integrity remains effective. The aim of the examination is to discover substantial corrosion, significant deformation, fractures, damages or other structural deterioration that may be present.

6.3.3 As indicated in Ch 3, Sec 3, [2.1.1], a bottom survey in dry condition is to be a part of the class renewal survey. The overall and close-up surveys and thickness measurements, as applicable, of the lower portions of the cargo tanks and ballast tanks are to be carried out during this bottom survey in accordance with the applicable requirements for class renewal surveys, if not already performed.

Lower portions of the cargo and ballast tanks are considered to be the parts below light ballast water line.

6.3.4 Where provided, the condition of the corrosion prevention system of cargo tanks is to be examined. A ballast tank is to be examined at subsequent annual surveys where:

- a hard protective coating has not been applied from the time of construction, or
- a soft or semi-hard coating has been applied, or
- substantial corrosion is found within the tank, or
- the hard protective coating is found to be in less than good condition and the hard protective coating is not repaired to the satisfaction of the Surveyor.

Thickness measurements are to be carried out as considered necessary by the Surveyor.

6.3.5 In the case of independent cargo tanks, the survey consists of:

- an external examination of cargo tanks
- an examination of cargo tank supports, chocks, keys and the adjacent hull structure with non-destructive testing if deemed necessary.

6.3.6 The Owner or his representative is to declare to the attending Surveyor that the arrangements in cargo tanks (including coating) related to the transported products are suitable for the purpose.

Figure 3 : Representative transverse section of chemical tanker - Areas ⑥ and ⑦

Midship section of chemical tanker (about 10 000DWT)

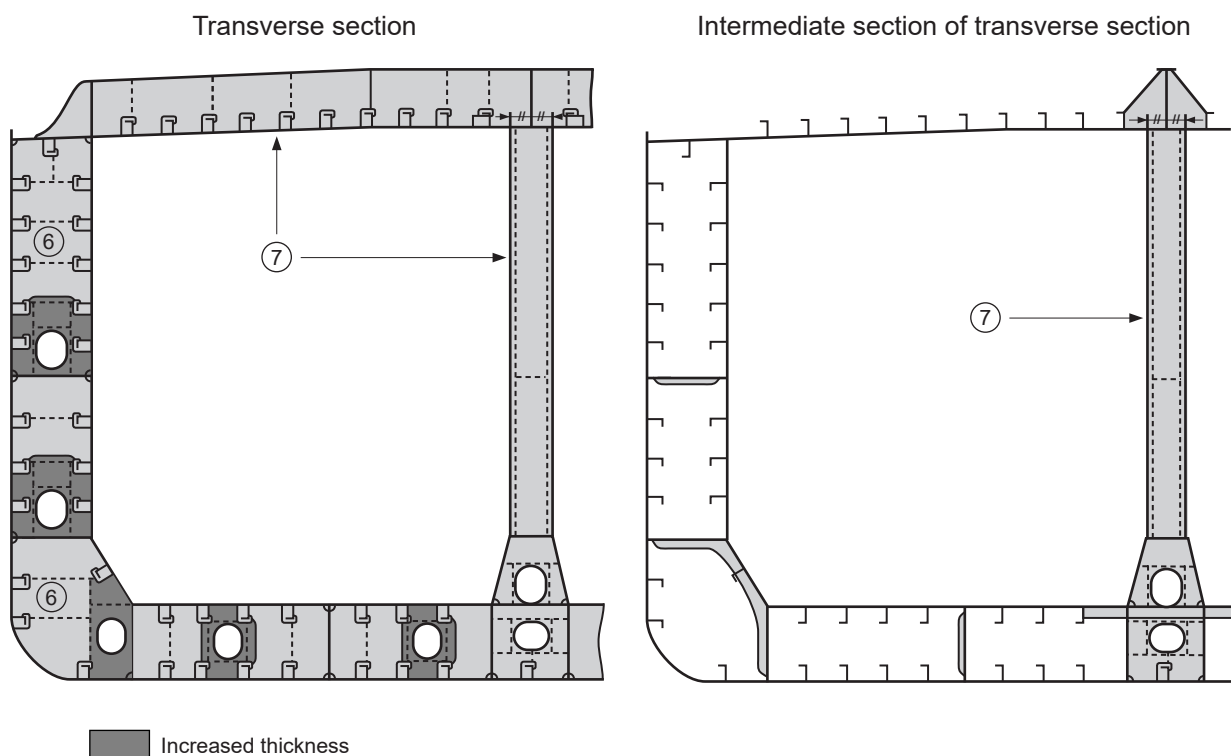


Table 2 : Requirements for close-up survey at class renewal survey of double skin chemical tankers

Age of ship (in years at time of class renewal survey)			
Class renewal survey No.1 age ≤ 5	Class renewal survey No.2 5 < age ≤ 10	Class renewal survey No.3 10 < age ≤ 15	Class renewal survey No.4 and subsequent age > 15
One web frame ring ①: - in a ballast double hull tank (1)	All web frame rings ①: - in a ballast wing tank, or - in a ballast double hull tank (1) The knuckle area and the upper part (3 metres approximately) of one web frame in each remaining ballast tank ⑥	All web frame rings: - in all ballast tanks ① - in a cargo wing tank ⑦ One web frame ring: - in each remaining cargo tank ⑦	As class renewal survey for ships between 10 and 15 years of age Additional transverse areas as deemed necessary by the Society
One deck transverse ②: - in a cargo tank or on deck	One deck transverse ②: - in two cargo tanks		
One transverse bulkhead ④: - in a ballast tank (1)	One transverse bulkhead ④: - in each ballast tank (1)	All transverse bulkheads: - in all cargo tanks ③ - in all ballast tanks ④	
One transverse bulkhead ⑤: - in a cargo wing tank - in a cargo centre tank (2)	One transverse bulkhead ⑤: - in a cargo wing tank - in two cargo centre tanks (2)		
<p>(1) Ballast double hull tank means double bottom tank plus double side tank plus double deck tank, as applicable, even if these tanks are separate.</p> <p>(2) Where no centre cargo tanks are fitted (as in the case of centre longitudinal bulkhead), transverse bulkheads in wing tanks are to be surveyed.</p> <p>Note 1: ①, ②, ③, ④, ⑤, ⑥ and ⑦ are areas to be subjected to close-up surveys and thickness measurements (see Fig 1, Fig 2 and Fig 3).</p> <p>① Web frame in a ballast tank means vertical web in side tank, hopper web in hopper tank, floor in double bottom tank and deck transverse in double deck tank (where fitted), including adjacent structural members. In fore and aft peak tanks web frame means a complete transverse web frame ring including adjacent structural members.</p> <p>② Deck transverse including adjacent deck structural members (or external structure on deck in way of the tank, where applicable).</p> <p>③ Transverse bulkhead complete in cargo tanks, including girder system, adjacent structural members (such as longitudinal bulkheads) and internal structure of lower and upper stools, where fitted.</p> <p>④ Transverse bulkhead complete in ballast tanks, including girder system and adjacent structural members, such as longitudinal bulkheads, girders in double bottom tanks, inner bottom plating, hopper side, connecting brackets.</p> <p>⑤ Transverse bulkhead lower part in cargo tanks, including girder system, adjacent structural members (such as longitudinal bulkheads) and internal structure of lower stool, where fitted.</p> <p>⑥ The knuckle area and the upper part (3 metres approximately), including adjacent structural members. Knuckle area is the area of the web frame around the connections of the slope hopper plating to the inner hull bulkhead and the inner bottom plating, up to 2 metres from the corners both on the bulkhead and the double bottom.</p> <p>⑦ Web frame in a cargo tank means deck transverse, longitudinal bulkhead structural elements and cross ties, where fitted, including adjacent structural members.</p>			

6.4 Overall and close-up surveys

6.4.1 Each class renewal survey is to include an overall survey of all tanks and all spaces.

6.4.2 The minimum requirements for close-up surveys are given in Tab 1 and Tab 2.

6.4.3 The survey of stainless steel tanks may be carried out as an overall survey supplemented by close-up survey as deemed necessary by the Surveyor.

6.4.4 The Surveyor may extend the close-up survey as deemed necessary, taking into account the maintenance of

the tanks under survey, the condition of the corrosion prevention system and also in the following cases:

- where tanks have structural arrangements or details which have suffered defects in similar spaces or on similar ships according to available information
- where tanks have structures approved with reduced scantlings.

6.4.5 For areas in tanks where hard protective coatings are found to be in good condition, as defined in Ch 2, Sec 2, [2.2.14], the extent of close-up surveys required according to Tab 1 and Tab 2 may be specially considered.

6.5 Thickness measurements

6.5.1 The minimum requirements for thickness measurements at class renewal survey are given in Tab 3. Thickness measurement of stainless steel hull structure and piping may be waived, except for clad steel plating.

6.5.2 Provisions for extended measurements for areas with substantial corrosion are given in Tab 4 and as may be additionally specified in the survey program as required in [6.1].

These extended thickness measurements are to be carried out before the survey is credited as completed.

Suspect areas identified at previous class renewal surveys are to be examined.

Areas of substantial corrosion identified at previous surveys are to have thickness measurements taken.

The Surveyor may further extend the thickness measurements as deemed necessary.

Table 3 : Requirements for thickness measurements at class renewal survey of chemical tankers

Age of ship (in years at time of class renewal survey)			
Class renewal survey No.1 age ≤ 5	Class renewal survey No.2 5 < age ≤ 10	Class renewal survey No.3 10 < age ≤ 15	Class renewal survey No.4 and subsequent age > 15
Suspect areas	Suspect areas	Suspect areas	Suspect areas
One section of deck plating for the full beam of the ship within the cargo area (in way of a ballast tank, if any, or a cargo tank used primarily for water ballast)	Within the cargo area: <ul style="list-style-type: none"> each deck plate one transverse section (1) 	Within the cargo area: <ul style="list-style-type: none"> each deck plate two transverse sections (1) (2) selected bottom plates all wind and water strakes 	Within the cargo area: <ul style="list-style-type: none"> each deck plate three transverse sections (1) (2) each bottom plate
Measurements, for general assessment and recording of corrosion pattern, of those structural members subject to close-up survey according to Tab 1 or Tab 2, as applicable	Measurements, for general assessment and recording of corrosion pattern, of those structural members subject to close-up survey according to Tab 1 or Tab 2, as applicable	Measurements, for general assessment and recording of corrosion pattern, of those structural members subject to close-up survey according to Tab 1 or Tab 2, as applicable	Measurements, for general assessment and recording of corrosion pattern, of those structural members subject to close-up survey according to Tab 1 or Tab 2, as applicable
	Selected wind and water strakes outside the cargo area	Selected wind and water strakes outside the cargo area	All wind and water strakes full length
(1) Transverse sections are to be chosen where the largest reductions are likely to occur or as revealed by deck plating measurements.			
(2) At least one section is to be within 0,5 L amidships and, where applicable, in way of a ballast tank.			

Table 4 : Extended thickness measurements at those areas of substantial corrosion Class renewal survey of chemical tankers within the cargo area length

BOTTOM, INNER BOTTOM AND HOPPER STRUCTURE		
Structural member	Extent of measurement	Pattern of measurement
Bottom, inner bottom and hopper structure plating	Minimum of 3 bays across tank, including aft bay Measurements around and under all suction bell mouths	5-point pattern for each panel between longitudinals and floors
Bottom, inner bottom and hopper structure longitudinals	Minimum of 3 longitudinals in each bay where bottom plating measured	3 measurements in line across the flange and 3 measurements on vertical web
Bottom girders, including the watertight ones	At fore and aft watertight floors and in centre of tanks	Vertical line of single measurements on girder plating with one measurement between each panel stiffener, or a minimum of 3 measurements 2 measurements across face flat where fitted
Bottom floors, including the watertight ones	3 floors in bays where bottom plating measured, with measurements at both ends and middle	5-point pattern over 2 m ² area
Hopper structure web frame ring	3 floors in bays where bottom plating measured	5-point pattern over 1 m ² of plating Single measurements on flange
Hopper structure transverse watertight bulkhead or swash bulkhead	• lower 1/3 of bulkhead	• 5-point pattern over 1 m ² of plating
	• upper 2/3 of bulkhead	• 5-point pattern over 2 m ² of plating
	• stiffeners (minimum of 3)	• For web, 5-point pattern over span (2 measurements across web at each end and 1 at centre of span). For flange, single measurements at each end and centre of span
Panel stiffening	Where applicable	Single measurements

DECK STRUCTURE		
Structural member	Extent of measurement	Pattern of measurement
Deck plating	2 transverse bands across tank	Minimum of 3 measurements per plate per band
Deck longitudinals	Every third longitudinal in each of 2 bands with a minimum of one longitudinal	3 measurements in line vertically on webs and 2 measurements on flange (if fitted)
Deck girders and brackets	At fore and aft transverse bulkhead, bracket toes and in centre of tanks	Vertical line of single measurements on web plating with one measurement between each panel stiffener, or a minimum of 3 measurements 2 measurements across flange 5-point pattern on girder/bulkhead brackets
Deck transverse webs	Minimum of 2 webs, with measurements at both ends and middle of span	5-point pattern over 1 m ² area Single measurements on flange
Vertical web and transverse bulkhead in wing ballast tank for double hull design (2 metres from deck)	Minimum of 2 webs, and both transverse bulkheads	5-point pattern over 1 m ² area
Panel stiffening	Where applicable	Single measurements

SIDE SHELL AND LONGITUDINAL BULKHEADS		
Structural member	Extent of measurement	Pattern of measurement
Side shell and longitudinal bulkhead plating: <ul style="list-style-type: none"> deckhead and bottom strakes and strakes in way of the horizontal girders all other strakes 	<ul style="list-style-type: none"> Plating between each pair of longitudinals in a minimum of 3 bays (along the tank) Plating between every third pair of longitudinals in same 3 bays 	Single measurement
Side shell and longitudinal bulkhead longitudinals on: <ul style="list-style-type: none"> deckhead and bottom strakes all other strakes 	<ul style="list-style-type: none"> Each longitudinal in same 3 bays Every third longitudinal in same 3 bays 	3 measurements across web and 1 measurement on flange
Longitudinals - brackets	Minimum of 3 at top, middle and bottom of tank in same 3 bays	5-point pattern over area of bracket
Vertical web and transverse bulkheads of double side tanks (excluding deck area): <ul style="list-style-type: none"> strakes in way of horizontal girders other strakes 	<ul style="list-style-type: none"> Minimum of 2 webs and both transverse bulkheads Minimum of 2 webs and both transverse bulkheads 	<ul style="list-style-type: none"> 5-point pattern over approximately 2 m² area 2 measurements between each pair of vertical stiffeners
Web frames and cross ties for other tanks than double side tanks	3 webs with minimum of 3 locations on each web, including in way of cross tie connections and lower end bracket	5-point pattern over approximately 2 m ² area of webs, plus single measurements on flanges of web frame and cross ties
Horizontal girders	Plating on each girder in a minimum of 3 bays	2 measurements between each pair of longitudinal girder stiffeners
Panel stiffening	Where applicable	Single measurements

TRANSVERSE WATERTIGHT AND SWASH BULKHEADS		
Structural member	Extent of measurement	Pattern of measurement
Upper and lower stool, where fitted	<ul style="list-style-type: none"> • Transverse band within 25 mm of welded connection to inner bottom/deck plating • Transverse band within 25 mm of welded connection to shelf plate 	5-point pattern between stiffeners over 1 m length
Deckhead and bottom strakes, and strakes in way of horizontal stringers	Plating between pair of stiffeners at 3 locations: approximately 1/4, 1/2 and 3/4 width of tank	5-point pattern between stiffeners over 1 m length
All other strakes	Plating between pair of stiffeners at middle location	Single measurement
Strakes in corrugated bulkheads	Plating for each change of scantling at centre of panel and at flange of fabricated connection	5-point pattern over about 1 m ² of plating
Stiffeners	Minimum of 3 typical stiffeners	For web, 5-point pattern over span between bracket connections (2 measurements across web at each bracket connection and 1 at centre of span). For flange, single measurements at each bracket toe and at centre of span
Brackets	Minimum of 3 at top, middle and bottom of tank	5-point pattern over area of bracket
Horizontal stringers	All stringers with measurements at both ends and middle	5-point pattern over 1 m ² area, plus single measurements near bracket toes and on flanges
Deep webs and girders	Measurements at toe of bracket and at centre of span	For web, 5 point pattern over about 1 m ² . 3 measurements across face flat

6.5.3 When pitting is found on bottom plating and its intensity is 20% or more, thickness measurements are to be extended in order to determine the actual plate thickness out of the pits and the depth of the pits. Where the wastage is in the substantial corrosion range or the average depth of pitting is 1/3 or more of the actual plate thickness, the pitted plate is to be considered as a substantially corroded area.

6.5.4 For areas in tanks where hard protective coatings are found to be in good condition, the extent of thickness measurements according to Tab 3 may be specially considered by the Society.

6.6 Tank testing

6.6.1 The requirements for tank testing at class renewal survey are given in Tab 5.

Table 5 : Requirements for tank testing at class renewal survey of chemical tankers

Age of ship (in years at time of class renewal survey)	
Class renewal survey No.1 age ≤ 5	Class renewal survey No.2 and subsequent age >5
All ballast tank boundaries	All ballast tank boundaries
Cargo tank boundaries facing ballast tanks, void spaces, pipe tunnels, pump rooms or cofferdams	All cargo tank bulkheads

6.6.2 Cargo tank testing carried out by the ship's crew under the direction of the Master may be accepted by the Surveyor, provided the following conditions are complied with:

- a) a tank testing procedure, specifying fill heights, tanks being filled and bulkheads being tested, has been submitted by the Owner and reviewed by the Society prior to the testing being carried out
- b) there is no record of leakage, distortion or substantial corrosion that would affect the structural integrity of the tank
- c) the tank testing has been satisfactorily carried out within the class renewal survey window, not more than 3 months prior to the date of the survey on which the overall or close-up survey is completed
- d) the satisfactory results of the testing is recorded in the ship's logbook
- e) the internal and external conditions of the tanks and associated structures are found satisfactory by the Surveyor at the time of the overall and close-up surveys.

6.6.3 The Surveyor may extend the tank testing as deemed necessary.

6.6.4 Boundaries of ballast tanks are to be tested with a head of liquid to the top of air pipes.

Boundaries of cargo tanks are to be tested to the highest point that liquid will rise under service conditions.

The testing of double bottom tanks and other spaces not designed for the carriage of liquid may be omitted, provided a satisfactory internal examination together with an examination of the tank top is carried out.

6.7 Cargo piping, cargo pump rooms and cargo tanks

6.7.1 Cargo piping on deck and cargo and ballast piping within the tanks specified in [6.3.2] are to be examined and operationally tested to working pressure to attending Surveyor's satisfaction to ensure that tightness and condition remain satisfactory. Special attention is to be given to any ballast piping in cargo tanks and cargo piping in ballast tanks and void spaces. Surveyors are to be advised on all occasions when this piping, including valves and fittings, is opened during repair periods and can be examined internally.

The Surveyor may require dismantling and/or thickness measurements of piping. A hydraulic test is to be carried out in the event of repair or dismantling of cargo or ballast piping, or where doubts arise.

Vent line drainage arrangements are to be examined.

6.7.2 It is to be verified that cargo piping and independent cargo tanks, where applicable, are electrically bonded to the hull.

6.7.3 For ships over 10 years of age, selected steel cargo pipes outside cargo tanks, cargo/slop discharge pipes passing through ballast tanks and void spaces and ballast pipes passing through cargo tanks are to be:

- subjected to thickness measurement at random, or selected pipe lengths are to be opened for internal inspection
- pressure tested to the maximum working pressure.

6.7.4 All safety valves on cargo piping and of cargo tanks are to be dismantled for examination, adjusted and, as applicable, resealed.

6.7.5 All cargo pump room boundaries are to be generally examined. All gas-tight shaft sealing devices are to be examined. The bottom of cargo pump rooms is to be presented clean for the examination of stripping devices and gutters.

6.8 Emergency towing arrangement

6.8.1 The survey is to include:

- an examination of the emergency towing arrangement
- confirmation that the arrangement is readily available with aft towing arrangement pre-rigged and forward chafing gear secured to the strong-point
- an examination of the pick-up gear, towing pennant and chafing gear over the full length for possible deterioration. Where the pennant line is stored in a watertight condition and can be confirmed as being maintained, consideration may be given to waiving the requirement to examine the pennant line over the full length
- an examination of the strong-points, fairleads and pedestal roller together with their attachments to the hull structure.

7 Class renewal survey - Cargo machinery items

7.1 Cargo area and cargo pump rooms

7.1.1 Ballast and stripping pumps are to be internally examined and prime movers checked. A working test is to be carried out.

Maintenance records of cargo pumps are to be made available to the Surveyor.

7.1.2 Where a washing system is fitted, piping, pumps, valves and deck-mounted washing machines are to be examined and tested for signs of leakage, and anchoring devices of deck-mounted washing machines are to be checked to the Surveyor's satisfaction.

7.1.3 The satisfactory condition of the cargo heating/cooling system is to be verified and, if deemed necessary by the Surveyor, the system is to be pressure tested.

7.1.4 Spares for cargo area mechanical ventilation fans are to be available on board.

7.1.5 Heat exchangers and anti-sparking fans are to be examined.

7.1.6 An operating test of the remote control of pumps and valves and of automatic closing valves is to be carried out.

7.1.7 A general examination of the electrical equipment and cables in dangerous zones such as cargo pump rooms and areas adjacent to cargo tanks is to be carried out for defective and non-certified safe type electrical equipment, non-approved lighting and fixtures, and improperly installed or defective or dead-end wiring.

The electrical insulation resistance of the electrical equipment and circuits terminating in or passing through the dangerous zones is to be tested; however, in cases where a proper record of testing is maintained, consideration may be given to accepting recent test readings effected by the ship's personnel.

7.2 Fire-fighting systems in cargo area

7.2.1 The survey is to include the examination of fire-fighting systems of any type fitted on board for the protection of the cargo area, cargo pump room and other dangerous spaces, such as deck foam, water-spraying and dry powder systems, as applicable in accordance with the relevant requirements given in Ch 3, Sec 3, [3.8].

7.3 Inert gas system

7.3.1 The requirements given in [5.2] for intermediate survey are to be complied with.

7.3.2 If an inert gas system such as that installed on board oil tankers is fitted, the requirements given in Ch 4, Sec 3, [7.3] for class renewal survey of oil tankers are to be complied with.

7.4 Personnel protection

7.4.1 The requirements given in [5.3] are to be complied with.

SECTION 5

LIQUEFIED GAS CARRIERS

1 General

1.1 Application

1.1.1 The requirements of this Section apply after construction to all self-propelled ships which have been assigned one of the following service notations:

- liquefied gas carrier
- liquefied gas carrier REGAS
- liquefied gas carrier REGAS STL-SPM
- liquefied gas carrier - FSRU
- liquefied gas carrier - FSU
- LNG bunkering ship.

1.1.2 The requirements apply to:

- the surveys of installations and equipment related to the carriage and handling of liquefied and revaporised gas when applicable, and
- the surveys of hull structure and related piping systems in way of cargo tanks, pump rooms, compressor rooms, cofferdams, pipe tunnels, void spaces and fuel oil tanks within the cargo area, and
- the surveys of all ballast tanks, and
- when fitted: revaporisation area and area of equipment for non permanent mooring, and for unloading to single buoy.

They are additional to the requirements applicable to the remainder of the ship, given in Part A, Chapter 3, according to the relevant surveys.

1.1.3 The requirements contain the minimum extent of examination, thickness measurements and tank testing. When substantial corrosion, as defined in Ch 2, Sec 2, [2.2.7], and/or structural defects are found, the survey is to be extended and is to include additional close-up surveys when necessary.

1.1.4 In any kind of survey, i.e. class renewal, intermediate, annual or other surveys having the same scope, thickness measurements, when required by Tab 3, of structures in areas where close-up surveys are required are to be carried out simultaneously with close-up surveys.

1.1.5 Consideration may be given by the attending Surveyor to allow use of remote inspection techniques (RIT) as an alternative to close-up survey, as defined in Ch 2, Sec 2. Surveys conducted using a RIT are to be completed to the satisfaction of the attending Surveyor.

When RIT is used for a close-up survey, temporary means of access for the corresponding thickness measurements as specified in this section is to be provided unless such RIT is also able to carry out the required thickness measurements.

For surveys conducted by use of a remote inspection technique, one or more of the following means of access, acceptable to the Surveyor, is to be provided:

- unmanned robot arm
- remote operated vehicle (ROV)
- unmanned aerial vehicles/drones
- other means acceptable to the Society.

1.1.6 When, in any survey, thickness measurements are required:

- the procedure detailed in Ch 2, Sec 2, [2.3] is to be applied
- the thickness measurement operator is to attend the survey planning meeting held prior to commencing the survey.

2 Annual survey - Hull items

2.1 General

2.1.1 The annual survey of cargo containment and cargo handling systems is preferably carried out during loading or unloading operations. Access to cargo tanks and/or inerted hold spaces is normally not required.

2.1.2 Gas plant operational record (log) entries since the last survey are to be examined in order to check the past performance of the system and to establish whether certain parts have shown any irregularities in operation. The boil-off rate, the hours per day of the reliquefaction plants and the inert gas consumption are also to be considered.

2.1.3 The relevant instruction and information material such as cargo handling plans, filling limit information, cooling down procedures, are to be verified as being onboard.

2.1.4 Examination of the condition of all piping systems, except those covered by [2.3].

Note 1: For survey of air pipes, flame screens on vents and ventilators, refer to Ch 3, Sec 1, [2.1.1].

2.2 Weather decks and suspect areas

2.2.1 Examination of flame screens on vents to all bunker tanks.

2.2.2 Examination the cargo, bunker, ballast and vent piping systems, including PRVs, vacuum relief valves, vent masts and protective screens.

2.2.3 Suspect areas identified at previous surveys are to be examined. Thickness measurements are to be taken of the areas of substantial corrosion and the extent of thickness measurements is to be increased to determine the extent of areas of substantial corrosion, as per the requirements of Tab 4.

These extended thickness measurements are to be carried out before the annual survey is credited as completed.

2.3 Cargo handling rooms and piping

2.3.1 The survey is to include:

- examination of cargo pump rooms, compressor rooms and cargo control rooms and, as far as practicable, pipe tunnels if fitted
- examination of the cargo machinery spaces and turret compartments, including their escape routes
- examination of all pump room and compressor room bulkheads for signs of leakage or fractures and, in particular, the sealing arrangements of all penetrations of pump room and compressor room bulkheads
- examination of all accessible gas-tight bulkhead penetrations including gas-tight shaft sealings
- examination of the sealing arrangements for tanks or tank domes penetrating decks or tank covers
- examination of the means for accomplishing gas tightness of the wheelhouse doors and windows. All windows and sidescuttles within the area required to be of the fixed type (non-opening) are to be examined for gas tightness. The closing devices for all air intakes and openings into accommodation spaces, service spaces, machinery spaces, control stations and approved openings in superstructures and deckhouses facing the cargo area or bow and stern loading/unloading arrangements, are to be examined
- examination of cargo and process piping, including the expansion arrangements, insulation from the hull structure, pressure relief and drainage arrangements and water curtain protection as appropriate
- examination of venting systems, including vent masts and protective screens, for cargo tanks, interbarrier spaces, hold spaces, fuel tanks and ballast tanks
- examination of cargo tank and interbarrier space relief valves and associated safety systems and alarms
- confirmation that the certificate for the relief valve opening/closing pressures is on board and that the cargo tank relief valves are sealed
- examination of drip trays or insulation for deck protection against cargo leakage
- confirmation of proper maintenance of arrangements for the airlocks
- confirmation that all accessible cargo piping systems are electrically bonded to the hull
- visual examination of arrangements for burning methane boil-off as far as practicable.

2.4 Other arrangements or devices

2.4.1 The survey is to include:

- confirmation that any liquid and vapour hoses are suitable for their intended purpose and in satisfactory condition and, where appropriate, type-approved or marked with date of testing
- confirmation that any special arrangement made for bow or stern loading/unloading is satisfactory
- confirmation that, if applicable, the provisions made for products which have special arrangements as per Pt D, Ch 9, Sec 17 are satisfactory
- confirmation that any special arrangements to survive conditions of damage are satisfactory
- examination, where applicable, of the alternative design and arrangements for the segregation of the cargo area, in accordance with the test, inspection and maintenance requirements, if any, specified in the approved documentation

2.5 Ballast tanks

2.5.1 Ballast tanks are to be internally examined when required as a consequence of the results of the class renewal survey or the intermediate survey; see [6.3.7] and footnote (3) of Tab 1, respectively.

2.5.2 When considered necessary by the Surveyor, or where extensive corrosion exists, thickness measurement is to be carried out. If the results of these thickness measurements indicate that substantial corrosion is found, then the extent of thickness measurements are to be increased to determine the extent of areas of substantial corrosion in accordance with the requirements given in Tab 4. These extended thickness measurements are to be carried out before the annual survey is credited as completed.

2.6 Emergency towing arrangement

2.6.1 The Owner or his representative is to declare to the attending Surveyor that no significant alterations have been made, without prior approval from the Society, to the equipment and arrangements fitted on board in accordance with the provisions given in Pt B, Ch 9, Sec 4, [3].

2.6.2 The survey is to include:

- an examination, as far as practicable, of the emergency towing arrangement
- confirmation that the aft towing arrangement is pre-rigged and forward chafing gear is secured to the strong-point
- confirmation of the proper functioning of the light, where it is provided, on the pick-up gear marker buoy.

3 Annual survey - Cargo machinery items

3.1 Cargo area and cargo pump rooms

3.1.1 The survey is to include:

- examination of mechanical ventilation fans in gas-dangerous spaces and zones
- examination, as far as practicable, and confirmation of the satisfactory operation of the arrangements for the artificial ventilation of spaces in the cargo area normally entered during operation
- examination and confirmation of the arrangements for the artificial ventilation of spaces normally entered other than above
- examination, as far as possible during operation, of the cargo handling piping and machinery, e.g. cargo and process piping, cargo heat exchangers, vaporizers, pumps, compressors and hoses.
- confirmation that fixed and/or portable ventilation arrangements provided for spaces not normally entered are satisfactory
- confirmation that the manually operated ESD (emergency shutdown) system together with the automatic shutdown of the cargo pumps and compressors are satisfactory
- examination of the gas detection safety arrangements for cargo control rooms and of the measures taken to exclude ignition sources when such spaces are classified as hazardous areas
- examination of cargo (if accessible), bilge, ballast and stripping pumps for excessive gland seal leakage
- confirmation that electrical equipment in hazardous areas is in satisfactory condition and has been properly maintained
- examination, as far as possible, of arrangements for the use of cargo as fuel, and associated instrumentation and safety devices.
- confirmation that, if fitted, cargo reliquefaction or refrigeration equipment is in satisfactory condition
- confirmation that relevant instruction and information material such as cargo handling plans, filling limit information, cooling down procedures, etc., is available on board.

3.2 Instrumentation and safety devices

3.2.1 The survey is to include:

- confirmation that installed pressure gauges on cargo discharge lines are operational (see Note 1)
- confirmation that cargo tank liquid level gauges are operational and that high level alarms as well as automatic shut-off systems are satisfactory (see Note 1)
- confirmation that the temperature indicating equipment of the cargo containment system and associated alarms are satisfactory (see Note 1)
- examination of the logbooks for confirmation that the emergency shutdown system has been tested

- confirmation that cargo tank, hold and insulation space pressure gauging systems and associated alarms are satisfactory (see Note 1)
- examination, and testing as appropriate, of fixed gas detection equipment
- examination of the arrangements for the cargo pressure / temperature control including, when fitted, the thermal oxidation systems and any refrigeration system and confirming that any associated safety measures and alarms are satisfactory
- confirmation of the availability and suitability of the portable gas detection equipment and instruments for measuring oxygen levels

Note 1: Verification of these devices is to be done by one or more of the following methods:

- visual external examination
- comparing of read outs from different indicators
- consideration of read outs with regard to the actual cargo and/or actual conditions
- examination of maintenance records with reference to cargo plant instrumentation maintenance manual
- verification of calibration status of the measuring instruments.

3.3 Fire-fighting systems in cargo area

3.3.1 The survey is to include:

- examination of fire-fighting systems of any type fitted on board for the protection of the cargo area, cargo pump room, cargo compressor room and other dangerous spaces, such as deck foam, water-spraying and dry powder systems, as applicable in accordance with the relevant requirements given in Ch 3, Sec 1, [3.4], including testing of the remote means of starting one main fire pump
- examination of the fixed fire-fighting system for the enclosed cargo machinery spaces, and the enclosed cargo motor room within the cargo area, and confirmation that its means of operation is clearly marked
- examination of the appropriate fire-extinguishing system for the enclosed cargo machinery spaces for ships that are dedicated to the carriage of a restricted number of cargoes and the internal water spray system for the turret compartments and confirmation that their means of operation is clearly marked.

3.4 Environmental control for cargo containment systems

3.4.1 The survey is to include:

- the examinations and tests as provided for the annual survey of inert gas systems of oil tankers, given in Ch 4, Sec 3, [3.4]
- confirmation that the use of inert gas has not increased beyond that needed to compensate for normal losses by examining records of inert gas usage
- confirmation that arrangements are made for sufficient inert gas to be carried to compensate for normal losses and that means are provided for monitoring the spaces

- confirmation that the means for prevention of backflow of cargo vapour to gas-safe spaces are in satisfactory operating condition
- confirmation that any air drying system and any inter-barrier and hold space purging inert gas system are satisfactory
- for membrane containment systems normal operation of the nitrogen control system for insulation and interbarrier spaces shall be confirmed to the Surveyor by the Master.

4 Intermediate survey - Hull items

4.1 General

4.1.1 A survey planning meeting is to be held prior to the commencement of the survey.

4.2 Weather decks, cargo handling rooms and piping

4.2.1 The survey is to include:

- examination, as far as applicable, of cargo and process, liquid nitrogen (if any), ballast, stripping and vent piping systems as well as vent masts and headers. If upon examination there is any doubt as to the condition of the piping, pressure testing, thickness measurement or both may be required
- examination of vent line drainage arrangements

- confirmation that cargo pipes and independent cargo tanks, where applicable, are electrically bonded to the hull.

4.3 Ballast tanks

4.3.1 The requirements for survey of ballast tanks given in Tab 1 are to be complied with.

4.3.2 For ships having independent tanks of type C, with a midship section similar to that of a general cargo ship, the extent of close-up surveys may be specially considered by the Society.

5 Intermediate survey - Cargo machinery items

5.1 General

5.1.1 The aim of the intermediate survey is to supplement the annual survey by testing cargo handling installations with related automatic control, alarm and safety systems for correct functioning.

5.1.2 The intermediate survey is preferably to be carried out with the ship in a gas-free condition. In fact, the extent of the testing required for the intermediate survey will normally be such that the survey cannot be carried out during a loading or discharging operation.

Table 1 : Intermediate survey of ballast tanks for liquefied gas carriers

Age of ship (in years at time of intermediate survey)		
5 < age ≤ 10	10 < age ≤ 15	age > 15
Overall survey of representative ballast tanks, selected by the attending Surveyor See (1), (2) and (3)	Overall survey of all ballast tanks See (1) and (3)	Overall survey of all ballast tanks See (1) and (3)
	Close-up survey of: - all web frames and both transverse bulkheads in a representative ballast tank (4) and (5) - the upper part of one web frame in another representative ballast tank - one transverse bulkhead in another representative ballast tank (5) See (6), (7) and (8)	Close-up survey of all web frames and both transverse bulkheads in two representative ballast tanks (4) and (5) See (6), (7) and (8)
<p>(1) If such surveys reveal no visible structural defects, the examination may be limited to a verification that the corrosion prevention system remains efficient.</p> <p>(2) If there is no hard protective coating, soft or semi-hard coating or poor coating condition, the examination is to be extended to other ballast tanks of the same type.</p> <p>(3) For ballast tanks, excluding double bottom tanks, if there is no hard protective coating, soft or semi-hard coating, or poor coating condition and it is not renewed, the tanks in question are to be internally examined at annual intervals. When such conditions are found in double bottom ballast tanks, the tanks in question may be internally examined at annual intervals.</p> <p>(4) Complete transverse web frame including adjacent structural members.</p> <p>(5) Transverse bulkhead complete, including girder system and adjacent members, and adjacent longitudinal bulkhead structure.</p> <p>(6) The extent of close-up surveys may be extended in accordance with the requirements of [6.4.3].</p> <p>(7) For areas in ballast tanks where protective coating is found to be in good condition, as defined in Ch 2, Sec 2, [2.2.14], the extent of close-up survey may be specially considered.</p> <p>(8) Ballast tanks include topside, double hull side, double bottom, hopper side, or any combined arrangement of the aforementioned, and peak tanks where fitted.</p>		

5.2 Cargo area and cargo pump rooms

5.2.1 Electrical equipment and cables in hazardous areas and zones such as cargo machinery spaces and areas adjacent to and above cargo tanks are to be examined for defective equipment, fixtures and cables as far as practicable and tested with particular regard to:

- protective earthing (spot check)
- integrity of enclosures
- damage of outer sheath of cables
- function test of pressurised equipment and associated alarms
- test of systems for de-energising non-certified safe electrical equipment located in spaces protected by airlocks, such as electric motor rooms, cargo control rooms, etc.

5.2.2 The electrical insulation resistance of the electrical equipment and circuits in dangerous zones is to be measured. These measurements are only to be effected when the ship is in a gas-free or inerted condition. Where a proper record of testing is maintained, consideration may be given to accepting recent readings by the ship's personnel.

5.2.3 In addition to the requirements of [5.2.1] and [5.2.2], the survey also consists of:

- confirmation that the cargo heating/cooling system is in satisfactory condition
- confirmation that spares are provided for cargo area mechanical ventilation fans
- confirmation that the heating system of the hull structure is in satisfactory working condition
- general examination and test of leakage detection systems in interbarrier and hold spaces.

5.3 Instrumentation and safety devices

5.3.1 The survey is to include:

- examination of the installed pressure gauging systems on cargo discharge lines, cargo tanks, holds and insulation spaces and associated alarms
- examination of the cargo tank liquid level gauges and high level alarms as well as automatic shut-off systems
- examination of the temperature indicating equipment of the cargo containment system and associated alarms
- test of the above-mentioned instrumentation by changing pressure, level and temperature as applicable and comparing with test instruments. Simulated tests may be accepted for sensors which are not accessible or located within cargo tanks or inerted hold spaces. The test is to include alarm and safety functions
- examination, as far as practicable, of the piping of the gas detection system for corrosion and damage. The integrity of the suction lines between suction points and analysing units is to be verified as far as possible

- calibration of gas detectors or verification thereof with sample gases
- confirmation that two sets of portable gas detection equipment suitable for the cargoes to be carried and a suitable instrument for measuring oxygen levels are provided
- test of the manually operated emergency shutdown system (without flow in the pipelines) to verify that the system will cause the cargo pumps and compressors to stop.

5.3.2 The arrangements for the use of cargo as fuel are to be examined, when applicable. It is to be tested, as far as practicable, that the gas supply to the machinery space is cut-off should the exhaust ventilation not be functioning correctly and that master gas fuel valve may be remotely closed from within the machinery space.

The instrumentation and safety systems for burning cargo as fuel are to be examined in accordance with [5.3.1].

5.4 Inert gas system

5.4.1 If an inert gas system such as that installed on board oil tankers is fitted, the requirements given in Ch 4, Sec 3, [5.2] for intermediate survey of oil tankers are to be complied with.

5.4.2 In the case of low temperature liquid nitrogen storage, the plant and its associated arrangements for protecting the hull structure against liquid nitrogen leakage are to be examined.

5.5 Personnel protection

5.5.1 The survey is to include:

- confirmation that two complete sets of safety equipment each permitting personnel to enter and work in a gas-filled space are provided and properly stowed
- confirmation that the requisite supply of compressed air is provided and examination, when applicable, of the arrangements for any special air compressor and low-pressure air line system
- confirmation that the medical first-aid equipment, including stretchers and oxygen resuscitation equipment and antidotes, when available, for the products to be carried are provided
- confirmation that respiratory and eye protection suitable for emergency escape purposes are provided
- confirmation that decontamination arrangements and eyewashes are operational
- examination, when applicable, of the arrangements to protect personnel against the effects of a major cargo release by a special suitably designed and equipped space within the accommodation spaces.

6 Class renewal survey - Hull items

6.1 Preparation for survey

6.1.1 The Owner is to provide the necessary facilities for a safe and practical execution of the surveys, including the means of providing access to structures for close-up survey, thickness measurements and tank testing. All other provisions described in Ch 2, Sec 2, [2.3], Ch 2, Sec 2, [2.5], Ch 2, Sec 2, [2.6], Ch 2, Sec 2, [2.7] and Ch 2, Sec 2, [2.9] regarding procedures for thickness measurements, conditions for survey, access to structures, equipment for survey and survey at sea or at anchorage, respectively, are also to be complied with.

6.2 Survey programme

6.2.1 A specific survey programme is recommended to be worked out in advance of the class renewal survey by the Owner in cooperation with the Society.

6.2.2 The survey programme is recommended to include conditions for survey, access to structures and equipment for surveys, taking into account the minimum requirements of Tab 2 and Tab 3 for close-up survey and thickness measurements, and [6.6] for tank testing.

6.3 Scope of survey

6.3.1 A survey planning meeting is to be held prior to the commencement of the survey.

6.3.2 In addition to the requirements of annual surveys, the class renewal survey is to include examination, tests and checks of sufficient extent to ensure that the hull and related piping, as required in [6.3.4], are in satisfactory condition and fit for the intended purpose for the new period of class to be assigned, subject to proper maintenance and operation and to periodical surveys being carried out at the due dates.

6.3.3 Ballast tanks, including double bottom tanks, pump rooms, compressor rooms, pipe tunnels, cofferdams and void spaces bounding cargo tanks, decks and outer hull are to be examined, and this examination is to be supplemented by thickness measurement and testing as required in [6.5] and [6.6], to ensure that the structural integrity remains

effective. The aim of the examination is to discover substantial corrosion, significant deformation, fractures, damages or other structural deterioration that may be present.

6.3.4 All piping systems within the above spaces, are to be examined and operationally tested to working pressure to attending Surveyor's satisfaction to ensure that tightness and condition remain satisfactory.

6.3.5 The survey extent of ballast tanks converted to void spaces is to be specially considered in relation to the requirements for ballast tanks.

Note 1: For survey of automatic air pipe heads, refer to Ch 3, Sec 3, Tab 1.

6.3.6 As indicated in Ch 3, Sec 3, [2.1.1], a bottom survey in dry condition is to be a part of the class renewal survey. The overall and close-up surveys and thickness measurements, as applicable, of the lower portions of the cargo holds and water ballast tanks are to be carried out in accordance with the applicable requirements for class renewal surveys, if not already performed.

Lower portions of the cargo holds and ballast tanks are considered to be the parts below light ballast water line.

6.3.7 Where provided, the condition of the corrosion prevention system of ballast tanks is to be examined.

For ballast tanks, excluding double bottom tanks, where a hard protective coating is found in poor condition and it is not renewed, where soft or semi-hard coating has been applied, or where a hard protective coating was not applied from time of construction, the tanks in question are to be examined at annual intervals. Thickness measurements are to be carried out as deemed necessary by the Surveyor.

When such breakdown of hard protective coating is found in double bottom ballast tanks and it is not renewed, where a soft or semi-hard coating has been applied, or where a hard protective coating was not applied from the time of construction, the tanks in question may be examined at annual intervals. When considered necessary by the Surveyor, or where extensive corrosion exists, thickness measurements are to be carried out.

6.3.8 Where the hard protective coating in ballast tanks is found to be in a good condition, the extent of close-up surveys and thickness measurements may be specially considered.

Table 2 : Requirements for close-up survey of ballast tanks at class renewal survey of liquefied gas carriers

Age of ship (in years at time of class renewal survey)		
Class renewal survey No.1 age ≤ 5	Class renewal survey No.2 5 < age ≤ 10	Class renewal survey No.3 and subsequent age > 10
One web frame in a representative ballast tank of the topside, hopper side and double hull side type (1)	All web frames in a ballast tank, which is to be a double hull side tank or a topside tank. If such tanks are not fitted, another ballast tank is to be selected (1)	All web frames in all ballast tanks (1)
	One web frame in each remaining ballast tank (1)	
One transverse bulkhead (3), in a ballast tank	One transverse bulkhead in each ballast tank (2)	All transverse bulkheads in all ballast tanks (2)
<p>(1) Complete transverse web frame including adjacent structural members.</p> <p>(2) Transverse bulkhead complete, including girder system and adjacent members, and adjacent longitudinal bulkhead structure.</p> <p>(3) Transverse bulkhead lower part, including girder system and adjacent structural members.</p> <p>Note 1: Ballast tanks include topside, double hull side, double bottom, hopper side, or any combined arrangement of the aforementioned, and peak tanks where fitted.</p>		

6.4 Overall and close-up surveys

6.4.1 An overall survey of all tanks and spaces, excluding fuel oil, lube oil and fresh water tanks, is to be carried out at each class renewal survey. However, for fuel oil, lube oil and fresh water tanks, the requirements given in Ch 3, Sec 3, Tab 2 are to be complied with.

6.4.2 Each class renewal survey is to include a close-up examination of sufficient extent to establish the condition of cargo tanks and ballast tanks. The minimum requirements for close-up surveys are given in Tab 2 for ballast tanks and in [6.7.3] for cargo tanks.

6.4.3 The Surveyor may extend the close-up survey as deemed necessary, taking into account the maintenance of the tanks under survey, the condition of the corrosion prevention system and also in the following cases:

- in particular, in tanks having structural arrangements or details which have suffered defects in similar tanks, or on similar ships according to available information
- in tanks having structures approved with reduced scantlings.

6.4.4 For areas in tanks where hard protective coatings are found to be in good condition, as defined in Ch 2, Sec 2, [2.2.14], the extent of close-up surveys required according to Tab 2 may be specially considered by the Society.

For ships having independent tanks of type C, with a midship section similar to that of a general cargo ship, the

extent of close-up surveys of ballast tanks may be specially considered by the Society.

Note 1: For survey of automatic air pipe heads, reference is to be made to Ch 3, Sec 3, Tab 1.

6.5 Thickness measurements

6.5.1 The minimum requirements for thickness measurements at class renewal survey are given in Tab 3.

6.5.2 The Surveyor may extend the thickness measurements as deemed necessary. When thickness measurements indicate substantial corrosion, the extent of thickness measurements is to be increased to determine the extent of areas of substantial corrosion in accordance with the requirements given in Tab 4.

6.5.3 For areas in tanks where hard protective coatings are found to be in good condition as defined in Ch 2, Sec 2, [2.2.14], the extent of thickness measurements according to Tab 3 may be specially considered by the Society.

6.5.4 For ships having independent tanks of type C, with a midship section similar to that of a general cargo ship, the extent of thickness measurements may be increased to the tank top plating to the satisfaction of the Surveyor.

6.5.5 Transverse sections are to be chosen where the largest reductions are suspected to occur or are revealed from deck plating measurements.

Table 3 : Requirements for thickness measurements at class renewal survey of liquefied gas carriers

Age of ship (in years at time of class renewal survey)			
Class renewal survey No.1 age ≤ 5	Class renewal survey No.2 5 < age ≤ 10	Class renewal survey No.3 10 < age ≤ 15	Class renewal survey No.4 and subsequent age > 15
Suspect areas	Suspect areas	Suspect areas	Suspect areas
One section of deck plating for the full beam of the ship within 0,5 L amidships in way of a ballast tank, if any	Within the cargo area: <ul style="list-style-type: none"> • each deck plate • one transverse section within 0,5 L amidships in way of a ballast tank, if any 	Within the cargo area: <ul style="list-style-type: none"> • each deck plate • two transverse sections (1) • all wind and water strakes 	Within the cargo area: <ul style="list-style-type: none"> • each deck plate • three transverse sections (1) • each bottom plate • duct keel plating and internals
Measurements, for general assessment and recording of corrosion pattern, of those structural members subject to close-up survey according to Tab 2	Measurements, for general assessment and recording of corrosion pattern, of those structural members subject to close-up survey according to Tab 2	Measurements, for general assessment and recording of corrosion pattern, of those structural members subject to close-up survey according to Tab 2	Measurements, for general assessment and recording of corrosion pattern, of those structural members subject to close-up survey according to Tab 2
	Selected wind and water strakes outside the cargo area	Selected wind and water strakes outside the cargo area	All wind and water strakes full length
(1) at least one section is to include a ballast tank within 0,5 L amidships, if any.			

Table 4 : Requirements for extent of thickness measurements at those areas of substantial corrosion

Structural member	Extent of measurement	Pattern of measurement
Plating	Suspect area and adjacent plates	5-point pattern over 1 m ² of plating
Stiffeners	Suspect area	3 measurements each in line across web and flange

6.6 Tank testing

6.6.1 All boundaries of ballast tanks and deep tanks used for water ballast within the cargo area are to be pressure tested. For fuel oil tanks, the representative tanks are to be pressure tested.

6.6.2 The Surveyor may extend the tank testing as deemed necessary.

6.6.3 Tank testing of fuel oil tanks is to be carried out with a head of liquid to the highest point that liquid will rise under service conditions. Tank testing of fuel oil tanks may be specially considered based on a satisfactory external examination of the tank boundaries, and a confirmation from the Master stating that the pressure testing has been carried out according to the requirements with satisfactory results.

6.7 Cargo tank structure

6.7.1 All cargo tanks are to be cleaned and examined internally.

6.7.2 When accessible, the outer surface of uninsulated cargo tanks or the outer surface of cargo tank insulation together with any vapour or protective barrier is to be examined. Special attention is to be given to the tank and insulation in way of chocks, supports and keys. Removal of insulation, in part or entirely, may be required in order to verify the condition of the tank or the insulation itself if deemed necessary by the Surveyor.

Where the arrangement is such that the insulation cannot be examined entirely, the surrounding structures of wing tanks, double bottom tanks and cofferdams are to be examined for cold spots when the cargo tanks are in the cold condition, unless voyage records together with the instrumentation give sufficient evidence of the integrity of the insulation system.

6.7.3 Thickness measurements may be required if deemed necessary by the Surveyor.

Close-up surveys are to be carried out in independent cargo tanks of type B and C at those areas where corrosion may develop.

6.7.4 Non-destructive testing is to supplement cargo tank inspection with special attention to be given to the integrity of the main structural members, tank shell and highly stressed parts, including welded connections as deemed necessary by the Surveyor.

However, for type C tanks, this does not mean that non-destructive testing can be dispensed with totally.

The following items are, inter alia, considered highly stressed areas:

- cargo tank supports and anti-rolling or anti-pitching devices
- web frames or stiffening rings

- Y-connection of shell plates and longitudinal bulkhead of bilobe tanks
- swash bulkhead boundaries
- dome and stump connections to the shell plating
- foundations for pumps, towers, ladders, etc.
- pipe connections.

6.7.5 For independent tanks of type B, the extent of non-destructive testing is to be as given in a program specially prepared for the cargo tank design.

6.7.6 The tightness of all cargo tanks is to be verified by an appropriate procedure. Provided that the effectiveness of the ship's gas detection equipment has been confirmed, it will be acceptable to utilise this equipment for the tightness test of independent tanks below deck.

6.7.7 Where the results of the examinations dealt with in [6.7.1] to [6.7.6] or the examination of the voyage records raise doubts as to the structural integrity of a cargo tank, a hydraulic or hydropneumatic test is to be carried out.

For integral tanks and for independent tanks of type A and B, the test pressure is not to be less than the MARVS.

For independent tanks of type C, the test pressure is not to be less than 1,25 times the MARVS.

6.7.8 When the ship is 10 years old, at every alternate class renewal survey, independent cargo tanks of type C are to be either:

- hydraulically or hydro-pneumatically tested to 1,25 times the MARVS, and thereafter non-destructively tested in accordance with [6.7.4], or
- subjected to thorough non-destructive testing in accordance with a program specially prepared for the tank design submitted by the Owner to the Society for acceptance. If a special program of non-destructive testing does not exist, special attention is to be given to the detection of surface cracks in welded connections in highly stressed areas as listed in [6.7.4]. At least 10% of the length of the welded connections in each of the above-mentioned areas is to be tested. This testing is to be carried out internally and externally, as applicable. Insulation is to be removed as necessary for the required non-destructive testing.

Where hold space atmosphere control is permanently maintained, the scope of external examination of the tanks and their supports may be reduced at the Surveyor's discretion.

6.7.9 As far as accessible, hold spaces and hull insulation (if provided), secondary barriers and tank supporting structures are to be visually examined. The secondary barrier of tanks is to be checked for its effectiveness by means of a pressure/vacuum test, a visual examination or any other acceptable method.

6.7.10 For membrane, semi-membrane and internal insulation tank systems, inspection and testing are to be carried out in accordance with programmes specially prepared in accordance with an approved method for the actual tank system.

For membrane containment systems, a tightness test of the primary and secondary barriers shall be carried out in accordance with the system designers' procedures and acceptance criteria as approved by the Society. Low differential pressure tests may be used for monitoring the cargo containment system performance, but they are not considered as an acceptable test for the tightness of the secondary barrier.

For membrane containment systems with glued secondary barriers, if the designer's threshold values are exceeded, an investigation is to be carried out and additional testing such as thermographic or acoustic emission testing should be carried out.

6.7.11 All gas-tight bulkheads are to be examined and the effectiveness of gas-tight shaft sealing is to be verified.

6.7.12 It is to be verified that independent cargo tanks are electrically bonded to the hull.

6.7.13 The pressure relief valves for the cargo tanks are to be opened for examination, adjusted, function tested and sealed. If the cargo tanks are equipped with relief valves with non-metallic membranes in the main or pilot valves, these non-metallic membranes are to be replaced. Where a proper record of continuous overhaul and re-testing of individually identifiable relief valves is maintained, consideration may be given to acceptance on the basis of opening, internal examination and testing of a representative sample of valves, including each size and type of liquefied gas or vapour relief valves in use, provided there is evidence in the log-book that the remaining valves have been overhauled and tested since crediting of the previous class renewal survey.

6.8 Weather decks, cargo handling rooms and piping

6.8.1 Piping for cargo and process, liquid nitrogen (if any), ballast, stripping and venting systems is to be examined to the Surveyor's satisfaction and opened as deemed necessary. Insulation is to be removed as deemed necessary to ascertain the condition of the pipes. If the visual examination raises doubts as to the integrity of the pipelines, a pressure test at 1,25 times the MARVS for the pipeline is to be carried out. After reassembly the complete piping systems are to be tested for leaks.

It is to be verified that cargo piping systems are electrically bonded to the hull.

6.8.2 The pressure relief valves on cargo piping are to be function tested. A random selection of valves is to be opened for examination and adjusted.

6.8.3 All cargo pump room, compressor room and control room boundaries are to be generally examined. Gas-tight shaft sealing devices are to be examined. The bottom of cargo pump rooms and cargo compressor rooms is to be presented clean for the examination of stripping devices and gutters.

6.8.4 Pressure/vacuum relief valves, rupture discs and other pressure relief devices for interbarrier spaces and/or hold spaces are to be examined and, if necessary, opened and tested in accordance with their design.

Vent line drainage arrangements are to be examined.

6.9 Emergency towing arrangement

6.9.1 The survey is to include:

- an examination of the emergency towing arrangement
- confirmation that the arrangement is readily available with aft towing arrangement pre-rigged and forward chafing gear secured to the strong-point
- an examination of the pick-up gear, towing pennant and chafing gear over the full length for possible deterioration. Where the pennant line is stored in a watertight condition and can be confirmed as being maintained, consideration may be given to waiving the requirement to examine the pennant line over the full length
- an examination of the strong-points, fairleads and pedestal roller together with their attachments to the hull structure.

7 Class renewal survey - Cargo machinery items

7.1 Cargo area, cargo pump rooms, cargo compressor rooms

7.1.1 Ballast and stripping pumps are to be internally examined and prime movers checked. A working test is to be carried out.

Maintenance records of cargo pumps are to be made available to the Surveyor.

7.1.2 Electrical equipment and cables in dangerous zones such as cargo pump rooms, cargo compressor rooms and spaces adjacent to and areas above cargo tanks are to be examined as far as practicable and tested with particular regard to:

- protecting earthing (spot check)
- integrity of enclosures
- damage of outer sheath of cables
- function testing of pressurised equipment and associated alarms
- testing of systems for de-energising non-certified safe electrical equipment located in spaces protected by airlocks, such as electric motor rooms, cargo control rooms, etc.

7.1.3 The electrical insulation resistance of the electrical equipment and circuits in dangerous zones is to be measured. These measurements are only to be effected when the ship is in a gas-free or inerted condition. Where a proper record of testing is maintained, consideration may be given to accepting recent readings by the ship's personnel.

7.1.4 When there is a reliquefaction or refrigeration plant, and/or arrangements for the use of cargo as fuel, the corresponding machinery and equipment, such as cargo pumps, compressors, heat exchangers, condensers and process pressure vessels, are to be surveyed to the same extent as required for similar equipment on board oil tankers at the class renewal survey (refer to Ch 4, Sec 3).

7.1.5 In addition to the requirements of [7.1.1] to [7.1.4], the survey also consists of:

- confirmation that spares are provided for cargo area mechanical ventilation fans
- confirmation that the installation for heating the hull structure is in satisfactory working condition
- general examination and testing of leakage detection systems in interbarrier spaces and hold spaces
- examination of gas detection piping system for corrosion or damage; checking, as far as possible, of the integrity of suction lines between suction points and analysing units
- examination and tests of systems for the removal of water from interbarrier spaces and hold spaces
- examination of portable equipment, such as hoses and spool pieces used for segregation of piping systems for cargo, inert gas and bilge pumping.

7.1.6 Cargo pumps, compressors, process pressure vessels, liquid nitrogen tanks, heat exchangers and other components, including prime movers, used in connection with cargo handling and methane boil-off burning are to be surveyed according to the requirements of Part A, Chapter 3.

7.2 Fire-fighting systems in cargo area

7.2.1 The survey is to include the examination of fire-fighting systems of any type fitted on board for the protection of the cargo area, cargo pump room, cargo compressor room and other dangerous spaces, such as deck foam, water-spraying, dry powder systems etc., as applicable in accordance with the relevant requirements given in Ch 3, Sec 3, [3.8].

7.3 Inert gas system

7.3.1 If an inert gas system such as that installed on board oil tankers is fitted, the requirements given in Ch 4, Sec 3, [7.3] are to be complied with.

7.3.2 In the case of low temperature liquid nitrogen storage, the plant and its associated arrangements for protecting the hull structure against liquid nitrogen leakage are to be examined.

7.4 Personnel protection

7.4.1 The requirements given in [5.5] are to be complied with.

8 First loaded voyage of ships carrying liquefied natural gases (LNG) in bulk

8.1

8.1.1 The survey requirements for the examination before and after the first loaded voyage for ships assigned with the service notation **liquefied gas carrier**, carrying liquefied natural gases (LNG) in bulk are to be carried out in accordance with Pt D, Ch 9, Sec 1, [6.2.4].

9 Revaporisation installation

9.1 Application

9.1.1 The requirements of this Article are applicable to self-propelled ships which have been assigned the notations:

- **liquefied gas carrier REGAS**, or
- **liquefied gas carrier REGAS STL-SPM**

These requirements apply to the revaporisation installation and to the area in way of this installation.

Reference is also made to other Articles of this Section for items dedicated to the revaporisation installation such as cargo tanks or control stations.

9.2 Annual survey

9.2.1 General

The annual survey of the revaporisation installation is preferably carried out during unloading operations with this installation in operation.

Revaporisation installation operational record entries (Bridge and Cargo logbooks) since the last survey are to be examined in order to check the past performance of the system and to establish whether certain parts have shown any irregularities in operation.

9.2.2 Equipment in contact with gas or in gas dangerous areas

The survey is to include:

- a) examination of the cargo suction drum(s) and their sealing arrangements if applicable
- b) examination of the areas dedicated to revaporisation equipments
- c) examination of closing devices of air intakes and openings into dedicated spaces for revaporisation if applicable
- d) examination of cargo and process piping, including the expansion arrangements, insulation from the hull structure, pressure control valves, inlet/outlet valves, drainage arrangements and high pressure manifolds
- e) examination of the relief valves, their sealing and associated safety systems and alarms
- f) confirmation that the certificate for the relief valves opening/closing pressures is on board

- g) examination of high pressure pumps as far as practicable (including gland leakage and vibration indications)
- h) external examination of vaporisers and their fittings
- i) external examination of heat exchangers
- j) examination of drip trays or insulation for deck protection and recesses against cargo leakage in revaporisation area
- k) confirmation that all accessible cargo piping systems and components (cargo suction drum(s), vaporisers, high pressure pumps) are electrically bonded to the hull.

9.2.3 Instrumentation and safety devices

The survey is to include examination of pressure gauges, control valves, metering unit, temperature and vibration indicating equipment. Particular attention is to be given to high pressure pumps instrumentation and safety devices.

Confirmation that the instrumentation fitted on revaporisation equipment and in contact with gas and associated alarms are satisfactory.

Examination and testing, as appropriate, of fixed gas detection equipment.

Examination of the logbooks for confirmation that the automatic emergency shut-down system has been tested. Confirmation that the automatic shut-down system is satisfactory.

9.2.4 Other arrangements or devices

The survey is to include confirmation that:

- relevant shipboard instructions and procedures of the revaporisation installation are available
- the revaporisation control station is in satisfactory working condition.

Water spraying system against gas leakage is to be surveyed in accordance with the relevant requirements given in Ch 3, Sec 1, [3.4].

Water deluge system is to be examined, including piping nozzles if fitted, and distribution valves. The starting of the pump is to be tested.

9.3 Intermediate survey

9.3.1 General

The aim of the intermediate survey is to supplement the annual survey by testing the revaporisation installation with related automatic control, alarm and safety systems for correct functioning.

9.3.2 Equipment in contact with gas or in gas dangerous areas

The maintenance records of vaporisers are to be reviewed. If deemed necessary by the Surveyor, thickness measurements, pressure test and/or opening-up and internal examination as far as practicable may be required. Particular attention is to be given to rupture device if fitted.

The survey is also to include:

- a) examination, as far as applicable, of stripping and vent piping systems and high pressure manifolds of cargo and process. If upon examination there is any doubt as to the condition of the piping, pressure testing, thickness measurement or both may be required
- b) examination of vent line drainage arrangements
- c) confirmation that cargo pipes and revaporisation components are electrically bonded to the hull
- d) random test of high pressure pumps lifting device
- e) thickness measurements of cargo suction drum(s) if deemed necessary by the Surveyor
- f) examination of electrical equipment according to [5.2].

9.3.3 Instrumentation and safety devices

The survey is to include examination of pressure gauges, control valves, metering unit, liquid level gauges, temperature and vibration indicating equipments, and associated alarms. Particular attention is to be given to high pressure pumps instrumentation and safety devices.

The above mentioned instrumentation is to be tested by changing pressure, level and temperature as far as practicable and comparing with test instruments. Simulated tests may be accepted for sensors which are not accessible. The test is to include alarms and safety functions.

The manually operated emergency shut-down system is to be operationally tested to verify that the system will cause the revaporisation installation to stop.

9.3.4 Other arrangements or devices

Water deluge system is to be tested as deemed necessary by the Surveyor.

9.4 Class renewal survey

9.4.1 General

In addition to the requirements of annual surveys, the class renewal survey is to include examination, tests and checks of sufficient extent to ensure that the revaporisation installation is in satisfactory condition for the new period of class to be assigned, subject to proper maintenance and operation and to periodical surveys being carried out at the due dates.

9.4.2 Cargo suction drum

The following requirements apply:

- a) Cargo suction drum(s) is (are) to be presented clean and examined internally.
- b) When accessible, the outer surface of uninsulated cargo suction drum(s) or the outer surface of unit insulation together with any vapour or protective barrier is to be examined. Particular attention is to be given to the stocking unit and insulation in way of supports. Removal of insulation, in part or entirely, may be required in order to verify the condition of the unit or the insulation itself if deemed necessary by the Surveyor.

- c) Thickness measurements or non-destructive testing may be required if deemed necessary by the Surveyor.
- d) The tightness of cargo suction drums is to be verified by an appropriate procedure.
- e) Where the results of the examinations in items a) to e) or the examination of the operational records raise doubts as to the structural integrity of the unit, a hydraulic or hydro pneumatic test is to be carried out. The test pressure is not to be less than 1,25 times the MARVS.
- f) When the ship is 10 years old, at every alternate class renewal survey, cargo suction drum(s) is (are) to be either: hydraulically tested and thereafter non-destructively tested or subjected to thorough non-destructive testing as per [6.7.8].
- g) As far as accessible, the cargo suction drum(s) supporting structures are to be visually examined.
- h) Their fittings, valves and safety devices are to be opened up, as deemed necessary by the Surveyor, for visual examination and pressure tested as appropriate.

9.4.3 Equipment in contact with gas or in gas dangerous areas

Piping for cargo and process, stripping, venting systems high pressure manifolds are to be examined to the Surveyor's satisfaction. Insulation is to be removed as deemed necessary to ascertain the condition of the pipes. If the visual examination raises doubts as to the integrity of the pipelines, a pressure test at 1,25 times the MARVS for the pipeline is to be carried out. After reassembly the complete piping systems are to be tested for leaks.

Maintenance records and log books of high pressure pumps including starting pumps are to be made available to the Surveyor. As deemed necessary by the Surveyor, the high pressure pumps are to be opened up for visual examination and their parts and components pressure tested. The lifting device is to be tested.

The bottom of the high pressure pump recess and vaporiser spaces are to be presented clean for the examination of gaskets and stripping devices.

The pressure relief valves are to be opened for examination, adjusted, function tested and sealed. The valves including inlet/outlet valves, pressure control valves and discharge valves are to be tested for proper operation.

The maintenance records of vaporisers are to be reviewed. The Surveyor may require as considered necessary:

- external and internal examination of vaporisers which are to be presented clean
- opening up of their fittings, valves and safety devices for visual examination and pressure tests
- thickness measurements and/or pressure test
- confirmation that cargo pipes and revaporisation components are electrically bonded to the hull.

Particular attention is to be taken in way of the vaporiser rupture device if fitted.

As deemed necessary by the Surveyor, the vaporisers heat exchangers are to be opened up for visual examination and their parts and components are to be pressure tested, as appropriate. A working test is also to be carried out, including testing of alarms and safety devices.

The electrical equipment are to be surveyed according to [7.1.2] and [7.1.3].

9.4.4 Instrumentation and safety devices

The survey is to include examination of pressure gauges, control valves, metering unit, liquid level gauges, temperature and vibration indicating equipments, and associated alarms. Particular attention is to be given to high pressure pumps instrumentation and safety devices.

The above mentioned instrumentation is to be tested by changing pressure, level and temperature as applicable and comparing with test instruments. Simulated tests may be accepted for sensors which are not accessible. The test is to include alarms and safety functions.

The emergency shut-down system is to be tested.

9.4.5 Other arrangements or devices

Water spraying system against gas leakage, when fitted, are to be surveyed in accordance with the relevant requirements given in Ch 3, Sec 3, [3.8].

For water deluge system:

- the associated pumps are to be opened up and examined at the Surveyor's discretion
- a working test is to be carried out.

10 STL-SPM

10.1 Application

10.1.1 The requirements of this Article apply to self-propelled ships which have been assigned the notations **liquefied gas carrier REGAS STL-SPM**. These requirements apply to the installation for non permanent mooring or for connection to single buoy and for cargo unloading and to the area in way of this installation.

Reference is also made to above Articles of this Section for items dedicated to the STL-SPM installation such as ventilation or fire fighting.

10.2 Annual survey

10.2.1 General

The Owner or his representative is to declare to the attending Surveyor that no significant alterations have been made without the prior approval of the Society.

Operational record (log) entries since the last survey are to be examined in order to check the past performance of the installation and to establish whether certain parts have shown any irregularities in operation.

10.2.2 Piping and flexible riser

The survey is to include:

- external examination of readily accessible parts including the outer sheath and the end fittings
- examination of pipes and their connections, of accessories including gas vent systems, bending restrictors, clamps and supports. Confirmation that there is no loose holding or connection
- examination of gas vent valves.

10.2.3 STL-SPM compartment, handling and connecting systems

The annual survey is to include:

- a general examination of components of the installation including winches, heave compensator and sheaves, rope guides, capstans, rope, hatch system, locking mechanism, quick release unit, sealing devices, chain stoppers, fairleads, pedestal roller and covers to verify their satisfactory condition.
- an examination of the hull structures supporting and adjacent to the installation, to verify that no deformations or fractures have developed. Particular attention is to be given to the lower part of the trunk, intermittently in contact with sea water.
- confirmation that emergency escape route is practicable and not blocked
- a visual examination of the lower hatch covers, the sealing arrangements as far as practicable, the supporting and locking devices.

10.2.4 Swivel system

The survey is to include:

- a) external examination of gas, electrical or/and hydraulic swivels with instrumentation and safety devices
- b) examination of piping systems including leak drainage system
- c) examination of connectors
- d) examination of handling arm when fitted
- e) tests of protective devices
- f) examination of support structure.

10.2.5 Others

The survey is to include:

- a) examination of pressure gauges, control valves, temperature and vibration indicating equipments
- b) confirmation that the instrumentation dedicated to STL-SPM and associated alarms are satisfactory
- c) examination and testing, as appropriate, of fixed gas detection equipment
- d) examination of the vent line drainage arrangements and the trunk structure
- e) examination of blast relief panels and verification that they are kept clear
- f) examination of the logbooks for confirmation that the emergency and automatic shutdown systems have been tested and confirmation that they are satisfactory

10.3 Intermediate survey

10.3.1 Cargo tanks requirements originated from STL-SPM

The review of logbooks is to be carried out with particular attention to control and surveillance data such as temperature, pressure, gas leakage detection.

Cargo tank(s) may be internally examined if deemed necessary by the Surveyor.

10.3.2 Instrumentation, safety device and others

The survey is to include examination of pressure gauges, control valves, liquid level gauges, temperature and vibration indicating equipments, and associated alarms.

The above mentioned instrumentation is to be tested by changing pressure, level and temperature as far as practicable and comparing with test instruments. Simulated tests may be accepted for sensors which are not accessible. The test is to include alarms and safety functions.

The emergency shutdown system is to be tested according to standard procedures (dry test).

If applicable, a test of quick disconnection (without flow in the pipelines) is to be carried out as far as practicable.

The drain pumps, including emergency pump are to be operationally tested.

10.4 Class renewal survey

10.4.1 General

In addition to the requirements of annual surveys, the class renewal survey is to include examination, tests and checks of sufficient extent to ensure that the STL-SPM installation is in satisfactory condition for the new period of class to be assigned, subject to proper maintenance and operation and to periodical surveys being carried out at the due dates.

Remote and/or automatic controls, alarms and safety devices are to be tested to demonstrate that they are in satisfactory condition.

10.4.2 Cargo tanks requirements originated from STL-SPM

The surveys detailed in [6.7] are to be carried out taking into account possible sloshing at intermediate filling levels (i.e. for independent cargo tank, with particular attention to upper and lower parts of the pump tower and its supports).

10.4.3 Piping and flexible riser

The survey is to include:

- a vacuum testing at vent holes in flexible pipe end fitting
- a pressure test if deemed necessary by the Surveyor
- an examination of the outer sheath. Removal of equipment hiding part of the pipe, may be required if deemed necessary by the Surveyor
- an internal examination, as far as practicable
- gas vent valves are to be examined and tested and, if deemed necessary by the Surveyor, opened up for internal examination.

10.4.4 STL-SPM compartment, handling and connecting systems

An examination of components is to be carried out with opening as deemed necessary by the Surveyor to verify their condition. Control and safety devices are to be tested. Guides and sheaves are to be examined for wear.

Satisfactory operation of the hatch covers is to be checked.

Thickness measurements or other non-destructive tests may be required by the Surveyor, where deemed necessary.

10.4.5 Swivel systems

The survey is to include:

- an internal examination of swivels
- a pressure test if deemed necessary by the Surveyor
- rotation tests, if deemed necessary, measurement of starting and running moments is to be carried out.

10.4.6 Instrumentation and safety devices

The survey is to include examination of pressure gauges, control valves, metering unit, liquid level gauges, temperature and vibration indicating equipments, and associated alarms.

The above mentioned instrumentation is to be tested by changing pressure, level and temperature as far as practicable and comparing with test instruments. Simulated tests may be accepted for sensors which are not accessible. The test is to include alarms and safety functions.

The emergency shut-down system is to be tested according to standard procedures.

A test of quick disconnection (without flow in the pipelines) is to be carried out.

The drain pumps, including emergency pump are to be operationally tested.

10.5 Bottom survey

10.5.1 The bottom survey is to include, as far as practicable:

- a visual examination of the shell plating in the submerged buoy recess
- a visual examination and an operational test of the lower hatch, including opening, closing and securing.

SECTION 6

RO-RO CARGO SHIPS, PCT CARRIERS, PASSENGER SHIPS, RO-RO PASSENGER SHIPS

1 General

1.1

1.1.1 The requirements of this Section are applicable after construction to all self-propelled ships which have been assigned one of the following service notations:

- **ro-ro cargo ship**
- **PCT carrier**
- **passenger ship**
- **ro-ro passenger ship.**

1.1.2 These requirements are additional to those laid down in Part A, Chapter 3, according to the relevant surveys.

2 Ro-ro cargo ships and PCT Carriers - Annual survey

2.1 Shell and inner doors

2.1.1 The requirements of this item apply to all shell and inner doors fitted on these ships.

2.1.2 For the scope of survey of shell and inner doors, the following definitions are applicable:

- **Securing device:** a device used to keep the door closed by preventing it from rotating about its hinges
- **Supporting device:** a device used to transmit external or internal loads from the door to a securing device and from the securing device to the ship's structure, or a device other than a securing device, such as a hinge, stopper or other fixed device, that transmits loads from the door to the ship's structure
- **Locking device:** a device that locks a securing device in the closed position.

2.1.3 It is to be checked that the operating procedures for closing the shell and inner doors are kept on board and posted at appropriate places.

When required, the Operating and Maintenance Manual is also to be checked for the verification of its approval and of any modification, reported repairs and proper endorsement by operating personnel.

Confirmation is to be obtained that no unapproved changes have been made to the bow, inner, side shell and stern doors since the last survey.

2.1.4 The structural arrangements as well as welding are to be examined, including:

- plating, primary structure and secondary stiffeners
- hinging arms, hinges and bearings, thrust bearings

- hull and door side supports of securing, supporting and locking devices
- shell plating surrounding the openings and the securing, supporting and locking devices.

Clearances of hinges, bearings and thrust bearings are to be taken, where no dismantling is required. Where the function test is not satisfactory, dismantling may be required to measure the clearances. If dismantling is carried out, a visual examination of hinge pins and bearings together with NDT of the hinge pin is to be carried out. Clearances of securing, supporting and locking devices are to be measured, where indicated in the OMM.

2.1.5 A close-up survey of securing, supporting and locking devices as listed below, including welding, is to be carried out:

- cylinder securing pins, supporting brackets, back-up brackets (where fitted) and their welded connections
- hinge pins, supporting brackets, back-up brackets (where fitted) and their welded connections
- locking hooks, securing pins, supporting brackets, back-up brackets (where fitted) and their welded connections
- locking pins, supporting brackets, back-up brackets (where fitted) and their welded connections
- locating and stopper devices and their welded connections.

2.1.6 A close visual inspection of sealing arrangements (packing material, rubber gaskets, packing retaining bars or channels) is to be carried out. For the tightness hose test, refer to [2.1.8].

2.1.7 The drainage arrangements including bilge wells, drain pipes and non-return valves are to be visually examined; confirmation that the provision of means to prevent blockage of drainage arrangements, for closed vehicle and ro-ro spaces and special category spaces where fixed pressure water-spraying systems are used, are satisfactory. A test of the bilge system between the inner and outer doors and that of the vehicle deck is to be carried out.

2.1.8 Function tests are to be carried out as follows, according to the required and/or existing equipment on board:

- a) doors are to be examined during a complete opening and closing operation; during this operation, the proper working of hinging arms and hinges, proper engagement of the thrust bearings and proper working of devices for locking the door in open position are to be checked
- b) securing, supporting and locking devices are to be examined during a complete opening and closing operation; the following items are to be checked:

- opening/closing system and securing/locking devices are interlocked in such a way that they can only operate in proper sequence
 - mechanical lock of the securing devices
 - the securing devices remain locked in the event of loss of hydraulic fluid, if they are of hydraulic type
- c) indicators of open/closed position of doors and of securing/locking devices at navigation bridge and other remote control stations are to be checked; other safety devices such as isolation of securing/locking hydraulic system from other hydraulic systems, access to operating panels, notice plates and warning indicator lights are to be checked
- d) a tightness hose test or equivalent of sealing arrangements is to be carried out
- e) a working test of the indicator system is to be carried out, including checking of:
- visual indicators and audible alarms on the navigation bridge and operating panel
 - lamp test function, fail safe performance, power supply for indicator system
 - proper condition of sensors and their protection from water, ice formation and mechanical damage
 - confirmation that power supply for indicator system is supplied by the emergency source or other secure power supply and is independent of the power supply for operating the doors
- f) a working test of the water leakage detection system for inner doors and for the area between the bow door and the inner door (as applicable) is to be carried out and the proper function of audible alarms on the navigation bridge and the engine control room panel (as applicable) is to be ascertained
- g) the television surveillance system is to be verified with proper indication on the navigation bridge and engine control room monitors
- h) electrical equipment for opening, closing and securing the doors is to be examined.

2.1.9 Non-destructive tests and/or thickness measurements may be required by the Surveyor after visual examination and function test or in cases where cracks or deformations have been found.

2.2 Internal platforms and ramps

2.2.1 The annual survey of internal movable platforms and ramps (excluding those considered as inner doors and covered in [2.1]) and related equipment consists of:

- a general examination of the installation, particular attention being paid to the condition of steel cables
- confirmation of the proper operation of platforms/ramps and of mechanical stops and locks
- checking, as far as practicable, of the alarms and safety devices.

2.3 Fire protection, detection and extinction

2.3.1 Within the scope of survey of fire protection, detection and extinction arrangements as required for the annual survey of all ships in Ch 3, Sec 1, [3.4], attention is to be given to the particular arrangements related to ro-ro cargo spaces, such as:

- fire detection systems and alarms
- fixed fire-extinguishing arrangements (gas, water-spraying or foam systems)
- means of control provided for closing various openings
- portable fire extinguishers in spaces and at entrances
- ventilation and related safety devices (including remote control on the bridge)
- electrical equipment of a safe type
- examination of the fire protection arrangements in cargo, vehicle and ro-ro spaces, including the fire safety arrangements for vehicle carriers carrying motor vehicles with compressed hydrogen or natural gas in their tanks for their own propulsion as cargo, as applicable, and
- examination and test of the portable gas detectors suitable for the detection of the gas fuel, for vehicle carriers carrying motor vehicles with compressed hydrogen or natural gas in their tanks for their own propulsion as cargo.

3 Ro-ro cargo ships and PCT carriers - Class renewal survey

3.1 Shell and inner doors

3.1.1 The class renewal survey is to include, in addition to the requirements of the annual survey as required in [2], examination, tests and checks of sufficient extent to verify that the bow, inner, side shell and stern doors are in satisfactory condition and considered able to remain in compliance with the applicable requirements, subject to proper maintenance and operation in accordance with the Operation and Maintenance Manual (OMM) or the manufacturer's recommendations and the periodical surveys being carried out at the due dates for the five-year period until the next class renewal survey.

3.1.2 The examinations of the doors are to be supplemented by thickness measurements and testing to verify compliance with the applicable requirements so that the structural and weathertight integrity remains effective. The aim of the examination is to identify corrosion, significant deformation, fractures, damages or other structural deterioration that may be present.

3.1.3 A close visual inspection of structural arrangements is to be carried out, supplemented by non-destructive tests and/or thickness measurements, as deemed necessary by the Surveyor.

3.1.4 A survey of the items listed in [2.1.4] and [2.1.5], including close-up survey of securing, supporting and locking devices, together with welding, is to be carried out.

Non-destructive testing and thickness measurements are to be carried out on securing, supporting and locking devices, including welding, to the extent considered necessary by the Surveyor. Whenever a crack is found, an examination with NDT is to be carried out in the surrounding area and for similar items, as considered necessary by the Surveyor.

3.1.5 Clearances of hinges, bearings and thrust bearings are to be taken. Unless otherwise specified in the OMM or by the manufacturer's recommendation, the measurement of clearances on ro-ro cargo ships may be limited to representative bearings where dismantling is needed in order to measure the clearances.

If dismantling is carried out, a visual examination of hinge pins and bearings together with NDT of the hinge pins are to be carried out.

3.1.6 Non-return valves of drainage arrangements are to be checked after dismantling.

3.1.7 The maximum thickness diminution of hinging arms, securing, supporting and locking devices is to be treated according to the normal procedure for primary structures, but is not to be more than 15% of the as-built thickness or the maximum corrosion allowance of the Society, whichever is less. Certain designs may be subject to the Society's special consideration.

3.1.8 Checking the effectiveness of sealing arrangements by hose testing or equivalent is to be carried out.

3.2 Internal platforms and ramps

3.2.1 The condition of pulleys, axles, cables and structure of the platforms and ramps is to be checked.

Electric motors and/or hydraulically operated equipment are to be surveyed according to the scope detailed in Ch 3, Sec 3, [3] for the class renewal survey of machinery installations.

3.3 Fire protection, detection and extinction

3.3.1 Within the scope of survey of fire protection, detection and extinction arrangements as required for the class renewal survey of all ships in Ch 3, Sec 3, [3.8], attention is to be given to the particular arrangements related to ro-ro cargo spaces, such as those indicated in [2.3.1].

4 Passenger ships - Annual survey

4.1 Watertight bulkheads

4.1.1 The survey of watertight bulkheads and arrangements consists of:

- examination, as far as practicable, of collision and watertight bulkheads, and confirmation that their watertight integrity has not been impaired
- checking the diagram provided on the navigation bridge showing the location of the watertight doors and related indicators for their open/closed position
- testing operation of local and remote control (from the navigation bridge) of the watertight doors, and in particular, operation from each side of the bulkhead of

audible alarms or visual signals and control handles, as required or fitted

- confirmation of operation of watertight doors in the event of failure of main and emergency sources of power
- confirmation that notices are affixed at appropriate locations.

4.2 Openings in shell plating

4.2.1 The survey consists of:

- examination of the arrangements for closing sidescuttles and their deadlights, as well as scuppers, sanitary discharges and similar openings and other inlets and discharges in the shell plating below the bulkhead deck
- confirmation that valves for closing the main and auxiliary sea inlets and discharges in the machinery spaces are readily accessible, and that indicators showing the status of the valves are provided, as required or fitted
- confirmation that gangway access and cargo ports fitted below the bulkhead deck may be effectively closed and that the inboard ends of any ash or rubbish chutes are fitted with an effective cover.

4.3 Miscellaneous

4.3.1 It is to be verified that the emergency escape routes from passenger and crew spaces, including related stairways and ladders, are kept clear.

5 Passenger ships - Class renewal survey

5.1

5.1.1 A lightweight survey is to be carried out to verify any changes in lightship displacement and in the longitudinal position of the centre of gravity. Where, in comparison with the approved stability information, a deviation exceeding 2% in the lightship displacement or a deviation of the longitudinal centre of gravity exceeding 1% of the length between perpendiculars is found or anticipated, the ship is to be submitted to a new inclining test.

5.1.2 The condition of the Low Location Lighting (LLL) system, where fitted, and its power source(s) is to be verified.

6 Ro-ro passenger ships - Annual and class renewal surveys

6.1

6.1.1 The scope of the annual survey and class renewal survey of **ro-ro passenger ship** is to include the scope of surveys required for the service notations **ro-ro cargo ship** and **passenger ship**, as detailed in [2] and [4] for annual survey and in [3] and [5] for class renewal survey.

6.1.2 In addition to [6.1.1], for both annual survey and class renewal survey, the condition of means of escape as well as of fire protection, detection and extinction in special category spaces is to be checked.

SECTION 7

GENERAL CARGO SHIPS

1 General

1.1 Application

1.1.1 The requirements of this Section apply to all self-propelled ships which have been assigned the service notation **general cargo ship** or **bulk carrier** (without the **ESP** additional service feature) of 500 GT and above carrying solid cargoes other than dedicated wood chip carriers and dedicated cement carriers.

The requirements of this Section do not apply to general dry cargo ships of double-skin construction, with double side-skin extending for the length of the cargo area, and over the height of the cargo hold to the upper deck.

Note 1: Special consideration may also be given to ships that are of double-skin construction but with single skin in way of several frame spaces, e.g. in way of a cargo hold entrance or in way of forebody hull form at the forward end of the foremost cargo hold.

In case of ships with hybrid cargo hold arrangements, e.g. with some cargo holds of single-side skin and others of double-side skin, the requirements of this Section are to be applied only to the structure in way of the single-side skin cargo hold region.

1.1.2 The requirements apply to surveys of hull structure and piping systems in way of cargo holds, cofferdams, pipe tunnels, void spaces and fuel oil tanks within the cargo area and all ballast tanks. They are additional to the requirements applicable to the remainder of the ship, given in Part A, Chapter 3 according to the relevant surveys.

1.1.3 The requirements contain the minimum extent of examination, thickness measurements and tank testing.

When substantial corrosion, as defined in Ch 2, Sec 2, [2.2.7], and/or structural defects are found, the survey is to be extended and is to include additional close-up surveys when necessary.

1.1.4 In any kind of survey, i.e. class renewal, intermediate, annual or other surveys having the same scope, thickness measurements, when required by Tab 5, of structures in areas where close-up surveys are required are to be carried out simultaneously with close-up surveys.

1.1.5 Consideration may be given by the attending Surveyor to allow use of Remote Inspection Techniques (RIT) as an alternative to close-up survey, as defined in Ch 2, Sec 2. Surveys conducted using a RIT are to be completed to the satisfaction of the attending Surveyor.

When RIT is used for a close-up survey, temporary means of access for the corresponding thickness measurements as specified in this section is to be provided unless such RIT is also able to carry out the required thickness measurements.

For surveys conducted by use of a remote inspection technique, one or more of the following means of access, acceptable to the Surveyor, is to be provided:

- unmanned robot arm
- remote operated vehicle (ROV)
- unmanned aerial vehicles/drones
- other means acceptable to the Society.

1.1.6 When, in any survey, thickness measurements are required, the procedure detailed in Ch 2, Sec 2, [2.3] is to be applied.

Note 1: Special consideration or specially considered (in connection with close-up surveys and thickness measurements) means sufficient close-up inspection and thickness measurements are to be taken to confirm the actual average condition of the structure under the coating.

1.2 Reporting and evaluation of surveys

1.2.1 A hull condition evaluation report (summarising the results of the class renewal surveys) is issued by the Society to the Owner, who is to place it on board the ship for reference at future surveys. The hull condition evaluation report is endorsed by the Society.

Note 1: This report does not apply to general dry cargo ships of double side-skin construction, with double side-skin extending over the entire length of the cargo area, and over the entire height of the cargo hold to the upper deck.

2 Annual survey

2.1 General

2.1.1 Suspect areas identified at previous surveys are to be examined. Thickness measurements are to be taken of the areas of substantial corrosion and the extent of thickness measurements is to be increased to determine the extent of areas of substantial corrosion, as per the requirements of Tab 6. These extended thickness measurements are to be carried out before the annual survey is credited as completed.

2.1.2 For survey of air pipes, flame screens on vents and ventilators, refer to Ch 3, Sec 1, [2.1.1].

2.1.3 For ships granted with the additional class notation **OPEN-HATCH**:

- confirmation that the operability and condition of the hold dewatering systems and freeing ports, if they are fitted, have been checked by the crew on a monthly basis and recorded in the ship's log book for annual verification by the Society
- examination of the water-spray system for open-top cargo holds in accordance with the relevant requirements given in Ch 3, Sec 1, [3.4.2], item d).

Table 1 : Annual survey of cargo holds for general cargo ships

Age of ship (in years at time of annual survey)	
10 < age ≤ 15	age > 15
Overall survey of one forward and one after cargo hold and their associated 'tweendeck spaces See (2)	Overall survey of all cargo holds and 'tweendeck spaces Close-up survey of sufficient extent, minimum 25% of frames, to establish the condition of the lower region of the shell frames including approximately the lower one third length of side frame at side shell and side frame end attachment and the adjacent shell plating in a forward lower cargo hold and one other selected lower cargo hold Examination of all piping and penetrations, including overboard piping, in all cargo holds See (1), (2) and (3)
<p>(1) Where this level of survey reveals the need for remedial measures, the survey is to be extended to include a close-up survey of all the shell frames and adjacent shell plating of those cargo holds and associated 'tweendeck spaces (as applicable) as well as a close-up survey of sufficient extent of all remaining cargo holds and 'tweendeck spaces (as applicable).</p> <p>(2) When considered necessary by the Surveyor, or where extensive corrosion exists, thickness measurements are to be carried out. If the results of these thickness measurements indicate that substantial corrosion is found, then the extent of thickness measurements is to be increased to determine the extent of areas of substantial corrosion, in accordance with Tab 6. These extended thickness measurements are to be carried out before the annual survey is credited as completed.</p> <p>(3) Where protective coating in cargo holds, as applicable, is found in good condition, the extent of close-up survey may be specially considered.</p>	

2.2 Hatch covers and coamings

2.2.1 The annual survey of hatch covers is to be carried out according to the requirements of Ch 3, Sec 1, [2.3].

In addition to these requirements, a close-up survey of hatch cover and hatch coaming plating and its stiffeners is to be carried out.

2.3 Cargo holds

2.3.1 The requirements given in Tab 1 are to be complied with.

2.4 Ballast tanks

2.4.1 Ballast tanks are to be internally examined when required as a consequence of the results of the class renewal survey or the intermediate survey; see [4.2.7] and footnote (3) of Tab 3.

2.4.2 When considered necessary by the Surveyor, or where extensive corrosion exists, thickness measurements are to be carried out. If the results of these thickness measurements indicate that substantial corrosion is found, then the extent of thickness measurements are to be increased to determine the extent of areas of substantial corrosion, in accordance with Tab 6. These extended thickness measurements are to be carried out before the annual survey is credited as completed.

3 Intermediate survey

3.1 General

3.1.1 A survey planning meeting is to be held prior to the commencement of the survey.

3.2 Ships 15 years of age or less

3.2.1 The requirements for survey of cargo holds given in Tab 2 are to be complied with.

3.2.2 The requirements for survey of ballast tanks given in Tab 3 are to be complied with.

3.3 Ships over 15 years of age

3.3.1 The scope of the intermediate survey of ships over 15 years of age is the scope of the preceding class renewal survey of hull, as detailed in [4], except for thickness measurements of each bottom plate within the cargo length area, and with bottom survey in dry condition or bottom in water-survey as applicable.

However, tank testing specified in [4.6], survey of automatic air pipe heads and internal examination of fuel oil, lube oil and fresh water tanks are not required unless deemed necessary by the attending surveyor.

This intermediate survey may be commenced at the second annual survey of the class period and be progressed during the succeeding year with a view to completion at the third annual survey.

Table 2 : Intermediate survey of cargo holds for general cargo ships

Age of ship (in years at time of intermediate survey)	
5 < age ≤ 10	10 < age ≤ 15
Overall survey of one forward and one after cargo hold and their associated 'tweendeck spaces Areas found suspect at the previous surveys are to be surveyed in accordance with the provisions indicated in [2.1.1]	Overall survey of all cargo holds and 'tweendeck spaces Areas found suspect at the previous surveys are to be surveyed in accordance with the provisions indicated in [2.1.1] See (1)
(1) When considered necessary by the Surveyor, or where extensive corrosion exists, thickness measurements are to be carried out. If the results of these thickness measurements indicate that substantial corrosion is found, then the extent of thickness measurements is to be increased to determine the extent of areas of substantial corrosion, in accordance with Tab 6. These extended thickness measurement are to be carried out before the survey is credited as completed.	

Table 3 : Intermediate survey of ballast tanks for general cargo ships

Age of ship (in years at time of intermediate survey)	
5 < age ≤ 10	10 < age ≤ 15
Overall survey of representative ballast tanks selected by the Surveyor See (1), (2) and (3)	Overall survey of all ballast tanks See (1) and (3)
Areas found suspect at the previous surveys are to be surveyed in accordance with the provisions indicated in [2.1.1]	Areas found suspect at the previous surveys are to be surveyed in accordance with the provisions indicated in [2.1.1]
<p>(1) If such overall survey reveals no visible structural defects, the examination may be limited to a verification that the corrosion prevention system remains efficient.</p> <p>(2) Where poor coating condition, soft or semi-hard coating, corrosion or other defects are found in ballast tanks or where a hard protective coating was not applied from the time of construction, the examination is to be extended to other ballast tanks of the same type.</p> <p>(3) In ballast tanks other than double bottom tanks, where a hard protective coating is found in poor condition and it is not renewed, where a soft or semi-hard coating has been applied or where a hard protective coating was not applied from time of construction, the tanks in question are to be examined and thickness measurements carried out as considered necessary at annual surveys.</p> <p>When such breakdown of hard protective coating is found in double bottom ballast tanks, where a soft or semi-hard coating has been applied or where a hard protective coating has not been applied, the tanks in question may be examined at annual surveys. When considered necessary by the Surveyor or where extensive corrosion exists, thickness measurements are to be carried out.</p>	

4 Class renewal survey

4.1 Preparation for survey

4.1.1 The Owner is to provide the necessary facilities for a safe and practical execution of the surveys, including the means of providing access to structures for close-up survey, thickness measurements and tank testing. All other provisions described in Ch 2, Sec 2, [2.3], Ch 2, Sec 2, [2.5], Ch 2, Sec 2, [2.6], Ch 2, Sec 2, [2.7] and Ch 2, Sec 2, [2.9] regarding procedures for thickness measurements, conditions for survey, access to structures, equipment for survey and survey at sea or at anchorage, respectively, are also to be complied with.

4.2 Scope of survey

4.2.1 A survey planning meeting is to be held prior to the commencement of the survey.

4.2.2 In addition to the requirements of annual surveys, the class renewal survey is to include examination, tests and checks of sufficient extent to ensure that the hull and related piping, as required in [4.2.4] are in satisfactory condition and

fit for the intended purpose for the new period of class to be assigned, subject to proper maintenance and operation and to periodical surveys being carried out at the due dates.

4.2.3 All cargo holds, ballast tanks, including double bottom tanks, pipe tunnels, cofferdams and void spaces bounding cargo holds, decks and outer hull are to be examined, and this examination is to be supplemented by thickness measurement and testing as required in [4.5] and [4.6] to ensure that the structural integrity remains effective. The aim of the examination is to discover substantial corrosion, significant deformation, fractures, damages or other structural deformation, that may be present.

4.2.4 All piping systems within the above spaces are to be examined and operationally tested to working pressure to attending Surveyor's satisfaction to ensure that tightness and condition remain satisfactory.

4.2.5 The survey extent of ballast tanks converted to void spaces is to be specially considered by the Society in relation to the requirements for ballast tanks.

Note 1: For survey of automatic air pipe heads, refer to Ch 3, Sec 3, Tab 1.

4.2.6 As indicated in Ch 3, Sec 3, [2.1.1], a bottom survey in dry condition is to be a part of the class renewal survey.

The overall and close-up surveys and thickness measurements, as applicable, of the lower portions of the cargo holds and ballast tanks are to be carried out in accordance with the applicable requirements for class renewal surveys, if not already performed.

Lower portions of the cargo holds and ballast tanks are considered to be the parts below light ballast water line.

4.2.7 Where provided, the condition of the corrosion prevention system of ballast tanks is to be examined.

For ballast tanks, excluding double bottom tanks, where a hard protective coating is found in poor condition and it is not renewed, where soft or semi-hard coating has been applied, or where a hard protective coating was not applied from time of construction, the tanks in question are to be examined at annual intervals. Thickness measurements are to be carried out as found necessary by the Surveyor.

When such breakdown of hard protective coating is found in double bottom ballast tanks and it is not renewed, where a soft or semi-hard coating has been applied, or where a hard protective coating was not applied from the time of construction, the tanks in question may be examined at annual intervals. When considered necessary by the Surveyor, or where extensive corrosion exists, thickness measurements are to be carried out.

4.2.8 Where the hard protective coating in tanks is found to be in good condition, the extent of close-up surveys and thickness measurements may be specially considered.

4.2.9 For ships granted with the additional class notation **OPEN-HATCH**:

- examination and complete test of the hold dewatering systems to check their proper functioning
- complete inspection of the open cargo holds
- operational testing and internal examination, as required by the Surveyor, of the relevant pumps for the water-spray system for open-top cargo holds.

4.3 Hatch covers and coamings

4.3.1 The requirements listed in Ch 3, Sec 3, [2.2.2] for all ships are to be complied with.

4.3.2 In addition to [4.3.1], the close-up survey and thickness measurements in accordance with the requirements given in Tab 4 and Tab 5, respectively, are to be carried out.

Subject to cargo hold hatch covers of approved design which structurally have no access to the internals, close-up survey/thickness measurement is to be done of the accessible parts of hatch cover structures.

4.4 Overall and close-up surveys

4.4.1 An overall survey of all cargo holds, tanks and spaces is to be carried out at each class renewal survey. However, for fuel oil, lube oil and fresh water tanks, the requirements given in Ch 3, Sec 3, Tab 2 are to be complied with.

4.4.2 The minimum requirements for close-up surveys at class renewal survey are given in Tab 4.

The Surveyor may extend the close-up survey as deemed necessary taking into account the maintenance of the spaces under survey, the condition of the corrosion prevention system and where spaces have structural arrangements or details which have suffered defects in similar spaces or on similar ships according to available information.

For areas in spaces where hard protective coatings are found to be in a good condition, the extent of close-up surveys according to Tab 4 may be specially considered.

Note 1: For survey of automatic air pipe heads, reference is to be made to Ch 3, Sec 3, Tab 1.

4.5 Thickness measurements

4.5.1 The minimum requirements for thickness measurements at class renewal survey are given in Tab 5.

4.5.2 The Surveyor may extend the thickness measurements as deemed necessary. When thickness measurements indicate substantial corrosion, the extent of thickness measurements is to be increased to determine the extent of areas of substantial corrosion in accordance with the requirements given in Tab 6.

4.5.3 For areas in spaces where hard protective coatings are found to be in a good condition, the extent of thickness measurements according to Tab 5 may be specially considered.

4.6 Tank testing

4.6.1 All boundaries of ballast tanks and deep tanks used for water ballast within the cargo length area are to be pressure tested. For fuel oil tanks, the representative tanks are to be pressure tested.

4.6.2 The Surveyor may extend the tank testing as deemed necessary.

4.6.3 Tank testing of fuel oil tanks is to be carried out with a head of liquid to the highest point that liquid will rise under service conditions. Tank testing of fuel oil tanks may be specially considered based on a satisfactory external examination of the tank boundaries, and a confirmation from the Master stating that the pressure testing has been carried out according to the requirements with satisfactory results.

Table 4 : Requirements for close-up survey at class renewal survey of general cargo ships

Age of ship (in years at time of class renewal survey)			
Class renewal survey No.1 age ≤ 5	Class renewal survey No.2 5 < age ≤ 10	Class renewal survey No.3 10 < age ≤ 15	Class renewal survey No.4 and subsequent age > 15
Selected shell frames in one forward and one aft cargo hold and associated 'tweendeck spaces ①	Selected shell frames in all cargo holds and 'tweendeck spaces ①	All shell frames in the forward lower cargo hold and 25% of shell frames in each of the remaining cargo holds and 'tweendeck spaces including upper and lower end attachments and adjacent shell plating ①	All shell frames in all cargo holds and 'tweendeck spaces including upper and lower end attachments and adjacent shell plating ①
One selected cargo hold transverse bulkhead ②	One transverse bulkhead in each cargo hold ② Forward and aft transverse bulkheads in one side ballast tank, including stiffening system ②	All cargo hold transverse bulkheads ② All transverse bulkheads in ballast tanks, including stiffening system ②	Areas ② to ⑥ as for class renewal survey for ships between 10 and 15 years of age
	One transverse web with associated plating and framing in two representative ballast tanks of each type (i.e. topside, hopper side, side tank or double bottom tank) ③	All transverse webs with associated plating and framing in each ballast tank ③	
All cargo hold hatch covers and coamings (plating and stiffeners) ④	All cargo hold hatch covers and coamings (plating and stiffeners) ④	All cargo hold hatch covers and coamings (plating and stiffeners) ④	
	Selected areas of all deck plating and underdeck structure inside line of hatch openings between cargo hold hatches ⑤	All deck plating and underdeck structure inside line of hatch openings between cargo hold hatches ⑤	
	Selected areas of inner bottom plating ⑥	All areas of inner bottom plating ⑥	
<p>Note 1: See Fig 1, Fig 2, Fig 3 and Fig 4 for areas ①, ②, ③, ④, ⑤ and ⑥.</p> <p>① Cargo hold transverse frames. ② Cargo hold transverse bulkhead plating, stiffeners and girders. ③ Transverse web frame or watertight transverse bulkhead in ballast tanks. ④ Cargo hold hatch covers and coamings. Subject to cargo hold hatch covers of approved design which structurally have no access to the internals, close-up survey/thickness measurement is to be done of the accessible parts of hatch cover structures. ⑤ Deck plating and underdeck structure inside line of hatch openings between cargo hold hatches. ⑥ Inner bottom plating.</p> <p>Note 2: Close-up survey of cargo hold transverse bulkheads to be carried out at the following levels: - immediately above the inner bottom and immediately above the 'tweendecks, as applicable - mid-height of the bulkheads for holds without 'tweendecks - immediately below the main deck plating and 'tweendeck plating.</p>			

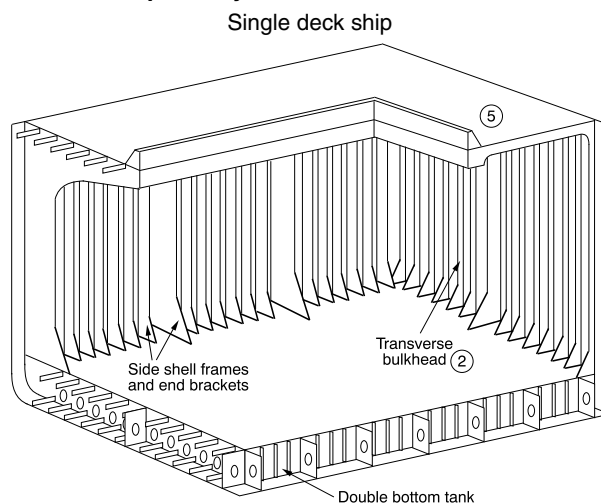
Figure 1 : Areas subject to close-up surveys and thickness measurements of general cargo ships

Figure 2 : Areas subject to close-up surveys and thickness measurements of general cargo ships

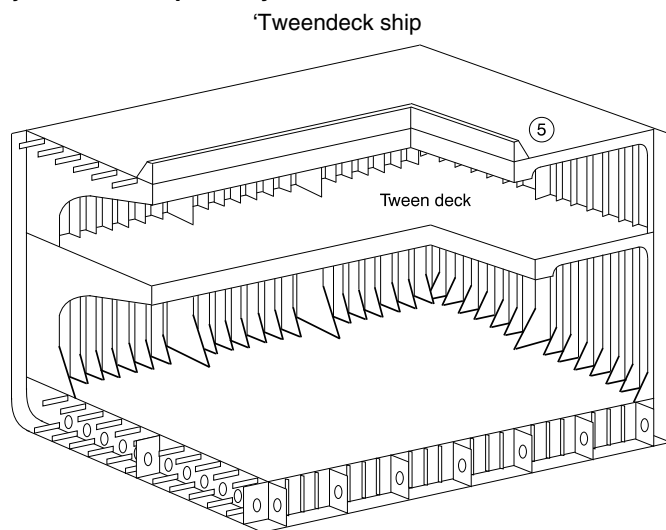


Figure 3 : Areas subject to close-up surveys and thickness measurements of general cargo ships

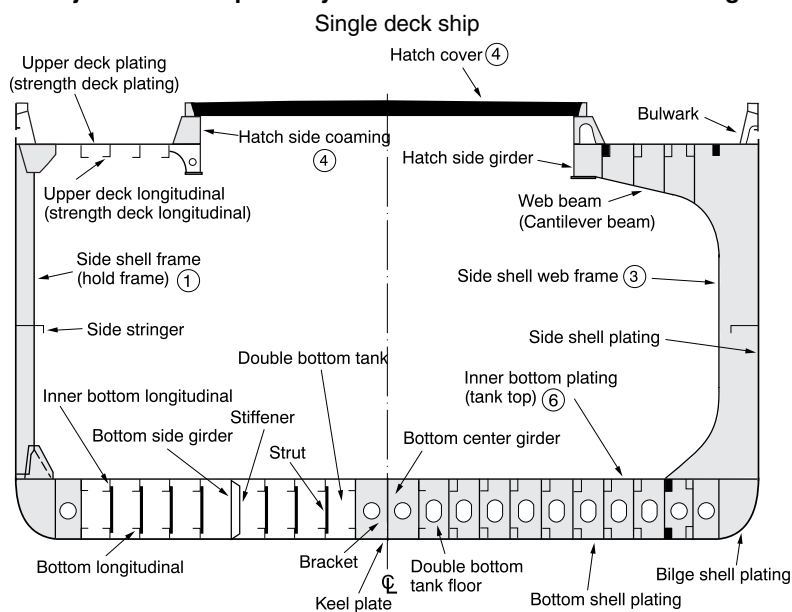


Figure 4 : Areas subject to close-up surveys and thickness measurements of general cargo ships

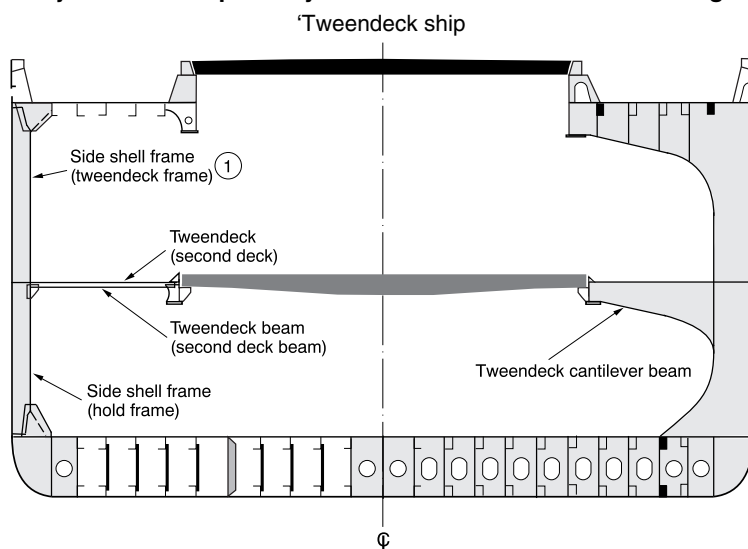


Table 5 : Requirements for thickness measurements at class renewal surveys of general cargo ships

Age of ship (in years at time of class renewal survey)			
Class renewal survey No.1 age ≤ 5	Class renewal survey No.2 5 < age ≤ 10	Class renewal survey No.3 10 < age ≤ 15	Class renewal survey No.4 and subsequent age > 15
Suspect areas	Suspect areas	Suspect areas	Suspect areas
	One transverse section of deck plating in way of a cargo space within the amidships 0,5 L (1)	Two transverse sections within the amidships 0,5 L in way of two different cargo spaces (1) Within the cargo length area, each deck plate outside line of cargo hatch openings	Within the cargo length area: <ul style="list-style-type: none"> • a minimum of three transverse sections within the amidships 0,5 L (1) • each deck plate outside line of cargo hatch openings • each bottom plate, including lower turn of bilge • duct keel or pipe tunnel plating and internals
	Measurement, for general assessment and recording of corrosion pattern, of those structural members subject to close-up survey according to Tab 4	Measurement, for general assessment and recording of corrosion pattern, of those structural members subject to close-up survey according to Tab 4	Measurement, for general assessment and recording of corrosion pattern, of those structural members subject to close-up survey according to Tab 4
		All wind and water strakes within the cargo area	All wind and water strakes full length
		Selected wind and water strakes outside the cargo area	
<p>(1) Transverse sections are to be chosen where the largest reductions are suspected to occur or are revealed from deck plating measurements.</p> <p>Note 1: Thickness measurement locations should be selected to provide the best representative sampling of areas likely to be most exposed to corrosion, considering cargo and ballast history and arrangement and condition of protective coatings.</p> <p>Note 2: For ships less than 100 metres in length, the number of transverse sections required for ships between 10 and 15 years of age may be reduced to one and the number of transverse sections for ships over 15 years of age may be reduced to two.</p>			

**Table 6 : Requirements for extent of thickness measurements at those areas of substantial corrosion
Class renewal survey of general cargo ships**

Structural member	Extent of measurement	Pattern of measurement
Plating	Suspect area and adjacent plates	5-point pattern over 1 m ² of plating
Stiffeners	Suspect area	3 measurements each in line across web and flange

SECTION 8

OTHER SERVICE NOTATIONS

1 General

1.1

1.1.1 The requirements of this Section are applicable to ships to be assigned one of the following service notations, and given in the Articles specified below:

- **container ship**, or ship **equipped for the carriage of containers**, in Article [2]
- **livestock carrier**, in Article [3]
- **FLS tanker**, in Article [4]
- dredging units, i.e. ships with the service notations **dredger**, **hopper dredger**, **hopper unit**, **split hopper unit**, **split hopper dredger**, in Article [5]
- **tug**, **salvage tug**, **escort tug**, in Article [6]
- **supply**, in Article [7]
- **fire-fighting**, in Article [8]
- **oil recovery**, in Article [9]
- **anchor handling**, in Article [10]
- **cable laying**, in Article [11]
- **lifting**, in Article [12]
- diving support, i.e. **diving support-integrated** or **diving support-portable**, in Article [13]
- **fishing vessel**, in Article [14]
- **standby rescue**, in Article [15]
- **yacht** and **charter yacht**, in Article [16].
- **semi-submersible cargo ship**, in Article [17].
- **diving systems**, in Article [18]
- **pipe laying**, in Article [19].

1.1.2 These requirements are additional to those given in Part A, Chapter 3, according to the relevant surveys.

1.1.3 The requirements for survey of diving systems assigned with one of the following notations are given in Article [18]:

- **diving system-integrated**
- **diving system-portable**
- **hyperbaric reception facility**.

2 Container ship or ship equipped for the carriage of containers

2.1 Annual survey

2.1.1 The survey is to include:

- confirmation of the availability of instructions and instruments for stowage of containers, as required or fitted
- examination of container supports welded to the ship's structure or on to the hatch covers
- examination of cell guides, if fitted.

2.2 Class renewal survey

2.2.1 The renewal is to include:

- examination of container supports welded to the ship's structure or on to the hatch covers, checking for possible cracks and deformations
- examination of cell guides and associated elements, checking for possible cracks, deformations or corrosion.

2.2.2 For ships assigned with the service notation **container ship**, examination of the torsion box girder or equivalent structure at the top sides is carried out. Thickness measurements additional to those related to the transverse sections may be required.

3 Livestock carrier

3.1 Annual survey

3.1.1 The survey is to include a general examination of:

- spaces for the livestock and related hatch covers (to be surveyed according to Ch 3, Sec 1, [2])
- ventilation means, including prime movers
- main, emergency and portable lighting systems in livestock spaces, passageways and access routes
- the drainage system
- fodder and fresh water systems
- fire-fighting appliances, with working test as far as necessary and practicable (according to Ch 3, Sec 1, [3.4])
- means of escape, with confirmation they are kept clear.

3.2 Class renewal survey

3.2.1 The equipment related to ventilation, lighting and the related power supply is to be submitted to a survey to the same extent as required for similar equipment at the class renewal survey as indicated in Ch 3, Sec 3.

3.2.2 The drainage, fodder and fresh water systems, including piping and pumps, are to be surveyed to the same extent as required for similar equipment at the class renewal survey as indicated in Ch 3, Sec 3.

The fresh water tanks are to be internally examined in accordance with the periodicity given in Ch 3, Sec 3, Tab 2.

3.2.3 The fire-fighting systems are to be thoroughly examined and tested.

4 FLS tanker

4.1 Annual survey - Hull items

4.1.1 Weather decks

The survey is to include:

- examination of cargo tank openings, including gaskets, covers, coamings and screens
- examination of cargo tank pressure/vacuum valves and flame screens
- examination of flame screens on vents to all bunker, oily ballast and oily slop tanks
- examination of cargo, bunker, ballast and vent piping systems, including remote control valves, safety valves and various safety devices, as well as vent masts and headers
- confirmation that wheelhouse doors and windows, sidescuttles and windows in superstructure and deckhouse ends facing the cargo area are in satisfactory condition
- confirmation that pumps, valves and pipelines are identified and distinctively marked.

4.1.2 Cargo pump rooms and pipe tunnels

The survey is to include:

- examination of all pump room bulkheads and pipe tunnels (if any) for signs of chemical cargo leakage or fractures and, in particular, the sealing arrangements of penetrations in pump room bulkheads
- examination of the condition of all piping systems, in cargo pump rooms and pipe tunnels (if any)
- examination of the bilge and ballast arrangements and confirmation that pumps and pipelines are identified.

4.2 Annual survey - Cargo machinery items

4.2.1 Cargo area and cargo pump rooms

The Owner or his representative is to declare to the attending Surveyor that no modifications or alterations which might impair safety have been made to the various installations in dangerous zones without prior approval from the Society.

The survey is to include:

- confirmation that potential sources of ignition in or near the cargo pump rooms, such as loose gear, excessive product in bilge, excessive vapours, combustible materials, are eliminated and that access ladders are in satisfactory condition

- examination, as far as practicable, of cargo, bilge, ballast and stripping pumps for excessive gland seal leakage, verification of proper operation of electrical and mechanical remote operating and shutdown devices and operation of pump room bilge system, and checking that pump foundations are intact
- confirmation that the ventilation system, including portable equipment, if any, of all spaces in the cargo area (including cargo pump room) is operational, ducting is intact, dampers are operational and screens are clean
- confirmation that electrical equipment in dangerous zones, cargo pump rooms and other spaces is in satisfactory condition and has been properly maintained
- confirmation that the remote operation of the cargo pump room bilge system is satisfactory
- examination of the cargo heating system
- examination of the cargo-transfer arrangement and confirmation that the ship's cargo hoses are suitable for their intended purpose and in satisfactory condition
- confirmation that any special arrangement made for bow or stern loading/unloading is in satisfactory condition.

4.2.2 Instrumentation and safety devices

The survey is to include the following items, as far as required or fitted:

- examination of cargo tank gauging devices, high level alarms and valves associated with overflow control
- confirmation that installed pressure gauges on cargo discharge lines are properly operational
- confirmation that the required gas detection instruments are on board and satisfactory arrangements have been made for the supply of any required vapour detection tubes
- confirmation that devices provided for measuring the temperature of the cargo, if any, operate satisfactorily.

4.2.3 Fire-fighting systems

The survey is to include:

- external examination of piping and cut-out valves of fixed fire-fighting systems related to cargo tanks and cargo pump rooms
- confirmation, as far as practicable and when appropriate, that the remote means for closing the various openings are operable
- examination of the appropriate portable fire-extinguishing equipment for the chemical cargoes to be carried in accordance with the relevant requirements given in Ch 3, Sec 1, [3.4.3]
- examination of fire-fighting systems of any type fitted on board such as deck foam, water-spraying, etc. as applicable in accordance with the relevant requirements given in Ch 3, Sec 1, [3.4.2].

4.2.4 Inert gas system

If an inert gas system such as that installed on board oil tankers is fitted, the requirements given in Ch 4, Sec 3, [3.4] are to be complied with.

4.3 Intermediate survey - Hull items

4.3.1 The survey is to include:

- examination, as far as applicable, of cargo, stripping, cargo washing, bunker, ballast, steam and vent piping systems as well as vent masts and headers. If upon examination there is any doubt as to the condition of the piping, pressure testing, thickness measurement or both may be required
- confirmation, if applicable, that cargo pipes are electrically bonded to the hull
- examination of vent line drainage arrangements.

4.4 Intermediate survey - Cargo machinery items

4.4.1 Electrical equipment in dangerous zones

A general examination of the electrical equipment and cables in dangerous zones such as cargo pump rooms and areas adjacent to cargo tanks is to be carried out for defective and non-certified safe type electrical equipment, non-approved lighting and fixtures, and improperly installed or defective or dead-end wiring.

The electrical insulation resistance of the electrical equipment and circuits terminating in or passing through the dangerous zones is to be tested; however, in cases where a proper record of testing is maintained, consideration may be given to accepting recent test readings effected by the ship's personnel.

4.4.2 Cargo heating system

The satisfactory condition of the cargo heating system is to be verified.

4.4.3 Inert gas system

For ships over 10 years old at the time of the intermediate survey due date, if an inert gas system such as that installed on board oil tankers is fitted, the requirements given in Ch 4, Sec 3, [5.2] for intermediate survey of oil tankers are to be complied with.

4.5 Class renewal survey - Hull items

4.5.1 Piping

Piping for cargo, ballast, stripping and venting systems is to be examined to the Surveyor's satisfaction. Dismantling and/or thickness measurements of these items may be required. A hydraulic test is to be carried out in the event of repair or dismantling of cargo or ballast piping, or where doubts arise.

Vent line drainage arrangements are to be examined.

It is to be verified, when applicable, that cargo piping is electrically bonded to the hull.

4.5.2 Safety valves

All safety valves on cargo piping and of cargo tanks are to be dismantled for examination, adjusted and, as applicable, resealed.

4.5.3 Cargo pump rooms

All cargo pump room boundaries are to be generally examined. All gas-tight shaft sealing devices are to be examined. The bottom of cargo pump rooms is to be presented clean for the examination of stripping devices and gutters.

4.6 Class renewal survey - Cargo machinery items

4.6.1 Pumps

Ballast and stripping pumps are to be internally examined and prime movers checked. A working test is to be carried out.

Maintenance records of cargo pumps are to be made available to the Surveyor.

4.6.2 Washing system

Where a washing system is fitted, piping, pumps, valves and deck-mounted washing machines are to be examined and tested for signs of leakage, and anchoring devices of deck-mounted washing machines are to be checked to the Surveyor's satisfaction.

4.6.3 Cargo heating system

The apparent satisfactory condition of the cargo heating system such as clamping, external condition of piping is to be verified and, if deemed necessary by the Surveyor, the system is to be pressure tested.

4.6.4 Remote controls

An operating test of the emergency remote control of pumps and valves and of automatic closing valves is to be carried out.

4.6.5 Electrical equipment in dangerous zones

A general examination of the electrical equipment and cables in dangerous zones such as cargo pump rooms and areas adjacent to cargo tanks is to be carried out for defective and non-certified safe type electrical equipment, non-approved lighting and fixtures, and improperly installed or defective or dead-end wiring.

The electrical insulation resistance of the electrical equipment and circuits terminating in or passing through the dangerous zones is to be tested; however, in cases where a proper record of testing is maintained, consideration may be given to accepting recent test readings effected by the ship's personnel.

4.6.6 Fire-fighting systems

The survey is to include the examination of fire-fighting systems of any type fitted on board for the protection of the cargo area, cargo pump room and other dangerous spaces, such as deck foam, water-spraying, etc., as applicable in accordance with the relevant requirements given in Ch 3, Sec 3, [3.8].

4.6.7 Inert gas system

If an inert gas system such as that installed on board oil tankers is fitted, the requirements given in Ch 4, Sec 3, [5.2] for intermediate survey and in Ch 4, Sec 3, [7.3] for class renewal survey of oil tankers are to be complied with.

5 Dredging units

5.1 Annual survey

5.1.1 The survey is to include the following items, as far as required or fitted, according to the service notation of the ship:

- for **split hopper unit, split hopper dredger**, visual examination, as far as practicable, of superstructure hinges and blocks, deck hinges, hydraulic jacks and associated piping systems and alarms
- for **dredger, hopper dredger, split hopper dredger**:
 - visual examination, as far as practicable, of attachments of suction piping and lifting systems to the structure and external examination of piping in dredging machinery spaces for absence of corrosion and leakage
 - checking the condition of the dredging machinery space and related equipment with regard to electrical shocks, protection from rotating machinery, fire and explosion hazards.

5.2 Class renewal survey

5.2.1 The survey is to include the following items, as far as required or fitted, according to the service notation of the ship:

- for **hopper dredger, hopper unit**, visual examination of hopper bottom doors or valves and accessories, such as hinges, actuating rods, hydraulic systems, with dismantling as deemed necessary by the Surveyor
- for **split hopper unit, split hopper dredger**, visual examination, as far as practicable, of superstructure hinges and blocks, deck hinges, hydraulic jacks and associated piping systems and alarms, with dismantling and/or further checks as deemed necessary by the Surveyor
- for **dredger, hopper dredger, split hopper dredger**:
 - visual examination, as far as practicable, of attachments of suction piping and lifting systems to the structure and external examination of piping in dredging machinery spaces for absence of corrosion and leakage
 - checking the condition of the dredging machinery space and related equipment with regard to electrical shocks, protection from rotating machinery, fire and explosion hazards.

6 Tug, salvage tug, escort tug

6.1 Annual survey

6.1.1 The survey is to include a general external examination of the towing hook or towing winch, as fitted, and unhooking device, as far as practicable.

6.1.2 In addition to [6.1.1], for **salvage tug**, the availability and satisfactory condition of specific equipment as required in Pt E, Ch 1, Sec 3, [4] is to be verified.

6.1.3 For **tug-barge combined**, an examination of the accessible parts of the connection system is to be carried out.

6.1.4 For tugs fitted with towing winch emergency release systems subject to Pt E, Ch 1, Sec 3, [2.7.4], the annual survey is to include:

- confirmation of the operation of the towing winch emergency release system with the reference to the documented instructions for surveys provided by the manufacturer. Operation of the winch emergency release system under no load condition is to be verified. Where practical, activation of the emergency release system may be confirmed by observation of the winch brake
- verification of the function of the alarms associated with the emergency release system, as far as practicable and reasonable
- visual examination of the condition of the emergency release system to confirm it remains in satisfactory condition
- examination of the means of emergency release of the towline in the event of a blackout, and where additional sources of energy are arranged for this purpose, visual inspection and operational test of the sources of energy
- verification that the performance capabilities and operating instructions of the emergency release system are documented and made available on board the ship on which the winch has been installed.

6.2 Class renewal survey

6.2.1 The survey is to include:

- checking the condition of the connection of the towing hook or towing winch to the structure, including related reinforcements of the structure
- checking the external condition of the towing hook or towing winch; when applicable, a no-load test of the unhooking device is to be carried out.

6.2.2 In addition to [6.2.1], for **salvage tug**, the survey is to include:

- a check and working test of specific equipment as required in Pt E, Ch 1, Sec 3, [4]
- checking by a specialist of the satisfactory condition of the towing line(s). A report is to be presented to the Surveyor by the Owner and kept on board.

6.2.3 For **tug-barge combined**, a visual examination of components of the connection system is to be carried out, completed by thickness measurements and non-destructive tests as deemed necessary by the Surveyor. A connection/disconnection test is to be carried out, including a check of related remote control, safety and alarm devices.

6.2.4 For ships granted with the additional service feature **standardized design bollard pull = $[T_{BP}/9,81]$ t**, the survey is to include a new bollard pull test as defined in Pt E, Ch 1, App 1, [9].

6.2.5 For tugs fitted with towing winch emergency release systems subject to Pt E, Ch 1, Sec 3, [2.7.4], the annual survey requirements are to be carried out, with the additional instructions for the class renewal survey provided by the manufacturer, as appropriate, being followed.

The full functionality of the emergency release system is to be tested to the satisfaction of the surveyor. Testing may be conducted either during a bollard pull test or by applying the load against a strong point on the deck of the tug or the shore that is certified to the appropriate load.

The emergency release system is to be tested at a towline load that is equal to the lesser of 30% of the maximum design load or 80% of vessel bollard pull in both a normal power condition and power blackout condition to the satisfaction of the surveyor.

7 Supply vessel

7.1 General

7.1.1 The additional survey items for annual survey, intermediate survey and class renewal survey are applicable only to ships having the service notation **supply** assigned the additional service features **HNLS** or **WELLSTIM**.

7.2 Annual survey - Hull items

7.2.1 Weather decks

The survey is to include:

- examination of cargo tank openings, including gaskets, covers, coamings and screens
- examination of cargo tank pressure/vacuum valves and flame screens
- examination of flame screens on vents to all bunker, oily ballast and oily slop tanks
- examination of cargo, bunker, ballast and vent piping systems, including remote control valves, safety valves and various safety devices, as well as vent masts and headers
- confirmation that wheelhouse doors and windows, sidescuttles and windows in superstructure and deckhouse ends facing the cargo area are in satisfactory condition
- confirmation that pumps, valves and pipelines are identified and distinctively marked.

7.2.2 Cargo pump rooms and pipe tunnels

The survey is to include:

- examination of all pump room bulkheads and pipe tunnels (if any) for signs of oil or chemical product leakage or fractures and, in particular, the sealing arrangements of penetrations in pump room bulkheads
- examination of the condition of all piping systems, in cargo pump rooms and pipe tunnels (if any)
- examination of the bilge and ballast arrangements and confirmation that pumps and pipelines are identified.

7.3 Annual survey - Cargo machinery items

7.3.1 Cargo area and cargo pump rooms

The Owner or his representative is to declare to the attending Surveyor that no modifications or alterations which might impair safety have been made to the various installations in dangerous zones without prior approval from the Society.

The survey is to include:

- confirmation that potential sources of ignition in or near the cargo pump rooms, such as loose gear, excessive product in bilge, excessive vapours, combustible materials, etc., are eliminated and that access ladders are in satisfactory condition
- examination, as far as practicable, of cargo, bilge, ballast and stripping pumps for excessive gland seal leakage, verification of proper operation of electrical and mechanical remote operating and shutdown devices and operation of pump room bilge system, and checking that pump foundations are intact
- confirmation that the ventilation system, including portable equipment, if any, of all spaces in the cargo area (including cargo pump rooms) is operational, ducting is intact, dampers are operational and screens are clean
- confirmation that electrical equipment in dangerous zones, cargo pump rooms and other spaces is in satisfactory condition and has been properly maintained
- confirmation that the remote operation of the cargo pump room bilge system, if fitted, is satisfactory
- examination of the cargo heating system
- examination of the cargo-transfer arrangement and confirmation that the ship's cargo hoses are suitable for their intended purpose and in satisfactory condition.

7.3.2 Instrumentation and safety devices

The survey is to include the following items, as far as required or fitted:

- examination of cargo tank gauging devices, high level alarms and valves associated with overflow control
- confirmation that installed pressure gauges on cargo discharge lines are properly operational
- confirmation that the required gas detection instruments are on board and satisfactory arrangements have been made for the supply of any required vapour detection tubes
- confirmation that devices provided for measuring the temperature of the cargo, if any, operate satisfactorily.

7.3.3 Fire-fighting systems

The survey is to include:

- external examination of piping and cut-out valves of fixed fire-fighting systems related to cargo tanks and cargo pump rooms
- confirmation, as far as practicable and when appropriate, that the remote means for closing the various openings are operable
- examination of the appropriate portable fire-extinguishing equipment for the cargoes to be carried in accordance with the relevant requirements given in Ch 3, Sec 1, [3.4.3]

- examination of fire-fighting systems of any type fitted on board such as deck foam, water-spraying etc. as applicable in accordance with the relevant requirements given in Ch 3, Sec 1, [3.4.2].

7.4 Intermediate survey - Hull items

7.4.1 The survey is to include:

- examination, as far as applicable, of cargo, stripping, bunker, ballast, steam and vent piping systems as well as vent masts and headers. If upon examination there is any doubt as to the condition of the piping, pressure testing, thickness measurement or both may be required
- confirmation that the pipelines are electrically bonded to the hull
- examination of vent line drainage arrangements.

7.5 Intermediate survey - Cargo machinery items

7.5.1 Electrical equipment in dangerous zones

A general examination of the electrical equipment and cables in dangerous zones such as cargo pump rooms and areas adjacent to cargo tanks is to be carried out for defective and non-certified safe type electrical equipment, non-approved lighting and fixtures, and improperly installed or defective or dead-end wiring.

The electrical insulation resistance of the electrical equipment and circuits terminating in or passing through the dangerous zones is to be tested; however, in cases where a proper record of testing is maintained, consideration may be given to accepting recent test readings effected by the ship's personnel.

7.5.2 Cargo heating system

The satisfactory condition of the cargo heating system is to be verified.

7.6 Class renewal survey - Hull items

7.6.1 Piping

Piping for cargo, ballast, stripping and venting systems is to be examined to the Surveyor's satisfaction. Dismantling and/or thickness measurements of these items may be required. A hydraulic test is to be carried out in the event of repair or dismantling of cargo or ballast piping, or where doubts arise.

Vent line drainage arrangements are to be examined.

It is to be verified that cargo piping is electrically bonded to the hull.

7.6.2 Safety valves

All safety valves on cargo piping and of cargo tanks are to be dismantled for examination, adjusted and, as applicable, resealed.

7.6.3 Cargo pump rooms

All cargo pump room boundaries are to be generally examined. All gas-tight shaft sealing devices are to be examined. The bottom of cargo pump rooms is to be presented clean for the examination of stripping devices and gutters.

7.6.4 Tank testing

Confirmation that cargo tank boundaries adjacent to machinery spaces, propeller shaft tunnels, if fitted, dry cargo spaces, accommodation and service spaces have been pressure tested.

If deemed necessary by the Surveyor, the tank testing may be extended.

7.7 Class renewal survey - Cargo machinery items

7.7.1 Pumps

Ballast and stripping pumps are to be internally examined and prime movers checked. A working test is to be carried out.

Maintenance records of cargo pumps are to be made available to the Surveyor.

7.7.2 Cargo heating system

The apparent satisfactory condition of the cargo heating system such as clamping, external condition of piping is to be verified and, if deemed necessary by the Surveyor, the system is to be pressure tested.

7.7.3 Remote controls

An operating test of the emergency remote control of pumps and valves and of automatic closing valves is to be carried out.

7.7.4 Electrical equipment in dangerous zones

A general examination of the electrical equipment and cables in dangerous zones such as cargo pump rooms and areas adjacent to cargo tanks is to be carried out for defective and non-certified safe type electrical equipment, non-approved lighting and fixtures, and improperly installed or defective or dead-end wiring.

The electrical insulation resistance of the electrical equipment and circuits terminating in or passing through the dangerous zones is to be tested; however, in cases where a proper record of testing is maintained, consideration may be given to accepting recent test readings effected by the ship's personnel.

7.7.5 Fire-fighting systems

The survey is to include the examination of fire-fighting systems of any type fitted on board for the protection of the cargo area, cargo pump room and other dangerous spaces, such as deck foam, water-spraying, dry powder systems etc., as applicable in accordance with the relevant requirements given in Ch 3, Sec 3, [3.8].

8 Fire-fighting ship

8.1 Annual survey

8.1.1 Ship's fire protection

The survey is to include:

- general examination of arrangements for structural fire protection

- ships equipped with a self-protection water-spraying system: general examination of all parts, as far as practicable and visible, of self-protection water-spraying system, and of scuppers and freeing ports for water drainage from deck surfaces
- ships not equipped with a self-protection water-spraying system: general examination of steel deadlights and shutters.

8.1.2 Water monitor system

The survey is to include:

- general examination of all parts of the water monitor system (pumps, piping system, valves and other fittings)
- checking for proper operation of the system, including local manual control
- general examination of foundations of water monitors and check of local manual control.

8.1.3 Fixed and portable foam systems

The survey is to include:

- general examination of the systems
- confirmation that the foam concentrates are periodically tested, either by the Manufacturer or by an organisation agreed by him
- general examination of foundations of foam monitors and check of local manual control
- for fixed foam systems, reference is to be made to Ch 3, Sec 1, [3.4.2], item e).

8.1.4 Machinery installations, control room and other devices

The survey is to include:

- general examination of spaces containing auxiliary machinery for fire-fighting systems, particular attention being paid to arrangements, piping systems and instruments; check of tools and of pressure vessels and their fittings, if any
- general examination of the control station and check of all communication and remote control means, of ventilation system
- general examination of sea suction of fire-fighting systems, of relevant remote and local control and of piping systems, including the relevant protection against corrosion
- general external examination of electrical installations for fire-fighting systems, with particular regard to the alarms and searchlights,
- checking of other fire-fighting arrangements
- checking of fire-fighter's outfits, confirmation that they are stored in the appropriate locations, and checking of air compressor and other equipment.

8.2 Class renewal survey

8.2.1 The survey is to include:

- complete test of water fire-extinguishing systems, including the internal examination, as required by the Surveyor, of the relevant pumps
- partial test, at the Surveyor's discretion, of fixed foam fire-extinguishing systems

- test of self-protection fixed water-spraying systems, putting into operation the spray nozzles, including the internal examination, as required by the Surveyor, of the relevant pumps
- examination and test of prime movers of machinery relevant to fire-fighting systems and of the air compressor for refilling of air bottles of breathing apparatuses
- examination and test of the electrical generating plant supplying power to fire-fighting systems and searchlights
- test of searchlights.

9 Oil recovery ship

9.1 Annual survey

9.1.1 The survey is to include:

- confirmation of the availability of the operating manual
- examination of cargo tank openings, including gaskets, covers, coamings and screens
- general examination of cargo, ballast and vent piping systems, including control, gauging, alarm and safety devices
- general examination of the cargo pump room, as regards ventilation systems, fire protection, detection and fire-fighting systems, condition of pumps and piping systems, and signs of any oil leakage
- confirmation that electrical equipment in dangerous areas, cargo pump rooms and other spaces, if fitted, is in satisfactory condition; the Owner or his representative is to declare to the attending Surveyor that this equipment has been properly maintained
- general examination of the dry powder fire extinguishers, as well as, if fitted, of the fixed or semi-fixed foam extinguishing system; the Owner is to show evidence that the foam concentrates have been periodically tested, either by the manufacturer or by an organisation agreed by him
- confirmation of the availability and satisfactory condition of the fixed cargo gas detection system, including related alarms, portable gas detection equipment, and oil flash point measurement equipment.

If any inert gas system is fitted, the requirements for the annual survey of such installations given in Ch 4, Sec 3, [3.4] are applicable.

9.2 Class renewal survey

9.2.1 Piping

Cargo, ballast, stripping and vent piping is to be examined to the Surveyor's satisfaction. Dismantling and/or thickness measurements may be required. Tightness or working tests are to be carried out. A hydraulic or hydropneumatic test is to be carried out in the event of repair or dismantling of cargo or ballast piping, or where doubts arise.

Vent line drainage arrangements are to be examined.

It is to be verified that cargo piping is electrically bonded to the hull.

9.2.2 Safety valves

Safety valves on cargo piping and of cargo tanks are to be dismantled for examination, adjusted and, as applicable, resealed.

9.2.3 Pumps

Ballast and stripping pumps are to be internally examined and prime movers checked. A working test is to be carried out.

Maintenance records of cargo pumps are to be made available to the Surveyor.

9.2.4 Cargo pump rooms

Cargo pump room boundaries are to be generally examined. Gas-tight shaft sealing devices are to be examined. The bottom of cargo pump rooms is to be presented clean for the examination of stripping devices and gutters.

9.2.5 Tank testing

Confirmation that oil recovery tank boundaries adjacent to engine rooms, if any, have been pressure tested.

If deemed necessary by the Surveyor, the tank testing may be extended.

9.2.6 Electrical equipment in dangerous zones

A general examination of the electrical equipment and cables in dangerous zones such as cargo pump rooms and areas adjacent to cargo tanks is to be carried out for defective and non-certified safe type electrical equipment, non-approved lighting and fixtures, and improperly installed or defective or dead-end wiring.

An insulation test of circuits is to be carried out; however, where a proper record of testing is maintained, consideration may be given to accepting recent readings effected by the ship's personnel.

9.2.7 Fire-fighting system

A partial test of fixed foam fire-extinguishing systems, if fitted, is to be carried out at the Surveyor's discretion.

9.2.8 Instrumentation and safety devices

The fixed cargo gas detection system, including related alarms, portable gas detection equipment, and oil flash-point measurement equipment, is to be tested.

9.2.9 Inert gas system

If any inert gas system is fitted, the requirements for the class renewal survey of such installations given in Ch 4, Sec 3, [7.3] are applicable.

10 Anchor handling vessel

10.1 Annual survey

10.1.1 The survey is to include:

- visual examination of winch, including drum, end flanges, reduction gears and brakes
- visual examination of wire stopper (i.e. shark jaw, karm fork), stern roller, guide pins
- visual examination of the wire length (wire rope or chain cable)
- visual examination of equipment foundations, including related reinforcements of the structure
- general examination of hydraulic and electric systems
- winch functional test with no load in order to detect vibration, leaks, shocks or sticking points and to check emergency stop and alarms
- braking system functional test with no load
- general examination and test, as far as practicable, of emergency quick-release system
- verification of manual or planning for anchor handling operation
- the review of the Owner's service record books is to be carried out. The purpose is to verify that:
 - periodical testing of the equipment has been carried out in accordance with relevant standards, when applicable
 - eventual repair, maintenance or replacement of equipment or components are done in accordance with applicable standards
 - on-board record showing the testing of the emergency quick-release system was checked.

10.2 Class renewal survey

10.2.1 In addition to the requirements of annual survey, the class renewal survey is to include, as a minimum:

- verification of the equipment condition with disassembly, as deemed necessary
- control of the safety devices with disassembly, as deemed necessary
- examination of the wire length (wire rope or chain cable) and gauging
- winch static load test, as deemed necessary
- testing of emergency quick-release system, as far as practicable
- examination of the integrity of critical components with respect to corrosion, wear, overload, fatigue and other possible modes of degradation, by visual inspection and other appropriate methods
- examination of bitter end connection to ship's structure.

11 Cable laying ship

11.1 Annual survey

11.1.1 The survey is to include:

- general examination of the connections of sheaves, drums and tensioners to the structure
- general examination of fire fighting equipment, if fitted, in way of cable storage spaces and working areas.

11.2 Class renewal survey

11.2.1 The equipment mentioned in [11.1.1] is to be dismantled, to the extent deemed necessary by the Surveyor, in order to check its condition. Clearances of sheaves and cable drum axles are to be ascertained.

11.2.2 Fire-fighting equipment is to be submitted to a survey to the same extent as required for similar equipment at the class renewal survey for all ships (see Ch 3, Sec 3).

12 Lifting

12.1 General

12.1.1 The requirements of this Article are additional to those laid down in NR526 Rules for the Certification of Lifting Appliances onboard Ships and Offshore Units or NR595 Classification of Offshore Handling Systems, whichever is applicable.

12.2 Annual survey

12.2.1 The survey is to include verification and testing of the lifting equipment, as follows:

- verification of the presence onboard of the following documents:
 - technical manual
 - planned maintenance system
- general examination of the electrical cabling
- functional testing of the main and alternative two-way communication system at the lifting operating position
- verification of the structural arrangement and foundations of the lifting equipment
- testing of hydraulic installations
- load tests in accordance with the rules or requirements referred to in the lifting equipment certificate.

12.3 Class renewal survey

12.3.1 The requirements given in Rule Notes NR526 and NR595 are applicable for renewal survey.

In addition, load tests in accordance with the rules or requirements referred to in the lifting equipment certificate are to be carried out.

13 Diving support-integrated and diving support-portable

13.1 Annual survey

13.1.1 The survey of the spaces containing the diving system, is to include:

- a) For non-permanent diving systems, verification that the service notation **diving support-capable** or **diving support-portable** is specified on the Certificate of Classification, in accordance with the configuration of the system
- b) Verification of the presence on-board of the following system documentation:
 - diving equipment technical manual
 - planned maintenance system
 - type approval certificates for the oxygen-measuring equipment
- c) Verification of the structural arrangement and scantling of the foundations of pressure vessels and bell handling system
- d) Verification of the fastening arrangement of the diving equipment
- e) Functional testing of the main source of electrical power, emergency source of electrical power and switching from one to the other. Verification of the satisfactory operation of the alarms and indications
- f) General examination of the electrical cabling
- g) Functional testing of the main and alternative two-way communication system at the dive location i.e. between divers, chambers, control rooms, launch point and other important locations
- h) Testing of the breathing gas installations:
 - general examination of the storage of the gas cylinders
 - verification of cleanliness of the breathing gas piping system according to the approved procedure
 - confirmation of the proper operation of the forced ventilation of the enclosed spaces for gas storage
 - verification of the means for the protection against overpressure of the oxygen installation
 - verification of the alarms of oxygen-measuring equipment
 - verification of the signboards in the area containing the gas cylinders
- i) General examination of the automatic fire detection and alarm system
- j) Verification of the suitable fixed fire-extinguishing system intended for interior spaces containing diving equipment
- k) Confirmation that the fire fighters' outfits including their self-contained compressed air breathing apparatus, and two-way portable communication apparatus, and emergency breathing masks are complete and in good condition and that the cylinders, including the spare cylinders, of any required self-contained breathing apparatus are suitably charged

- l) Confirmation that doors located in bulkheads forming boundaries with adjacent spaces are in a satisfactory condition
- m) General examination of the visible parts of items forming the structural fire protection, such as bulkheads, decks, doors and trunks, due attention being given to their integrity and to integrity of the insulating material.

13.2 Class renewal survey

13.2.1 In addition to the requirements of annual survey, the class renewal survey of the spaces containing the diving system is to include:

- a) testing of the breathing gas installations, i.e. testing of the gas-tightness of all sealing devices of the enclosed spaces for breathing gas storage
- b) functional testing of self closing systems of door located in bulkheads forming boundaries with adjacent spaces
- c) verification of accuracy of oxygen-measuring equipment by means of calibration gas, as far as practicable
- d) verification of the sea inlet protective structure, as relevant.

14 Fishing vessel

14.1 Annual survey

14.1.1 The survey is to include:

- general examination of areas subject to damage, corrosion or wastage, such as the stern ramp, weather deck in way of the working area of the nets, connections to hull structure of masts, gantries, winches and trawl gallows (for side trawlers)
- general examination of the measures for the protection of the crew against falling overboard, such as storm rails, means of protection near stern ramp, etc.

14.2 Class renewal survey

14.2.1 For fishing vessels 10 years age and over, the class renewal survey is to include thickness measurements of structural elements prone to rapid wastage, such as the stern ramp, weather deck in way of the working area of the nets, connections to hull structure of masts, gantries, winches and trawl gallows (for side trawlers).

15 Standby and rescue vessel

15.1 Annual survey - Rescue arrangement, survivors accommodation and safety equipment

15.1.1 A general examination of rescue equipment and facilities, survivors spaces, safety equipment, personal care and medical provisions, in accordance with the requirements given in Part E, Chapter 10, is to be carried out.

15.2 Annual survey - Towing arrangements

15.2.1 A general external examination of the towing hook or towing winch, as fitted, and unhooking device, as far as practicable, is to be carried out.

15.3 Class renewal survey - Rescue arrangement, survivors accommodation and safety equipment

15.3.1 A general examination of rescue equipment and facilities, survivors spaces, safety equipment, personal care and medical provisions, in accordance with the requirements given in Part E, Chapter 10, is to be carried out.

Testing of rescue and safety equipment, as applicable, is to be carried out.

15.4 Class renewal survey - Towing arrangements

15.4.1 The survey is to include:

- checking the condition of the connection of the towing hook or towing winch to the structure, including related reinforcements of the structure
- checking the external condition of the towing hook or towing winch; when applicable, a no-load test of the unhooking device is to be carried out.

16 Yacht and charter yacht

16.1 Intermediate survey

16.1.1 The survey requirements for intermediate survey of hull and hull equipment are given in Ch 3, Sec 2 and in Rule Note NR500, Rules for the Classification and Certification of Yachts.

The survey requirements for intermediate survey of machinery and systems for ships assigned with the service notation **yacht** and having a length less than 24 m are indicated in Ch 3, Sec 1, [3].

16.2 Class renewal survey

16.2.1 The requirements for class renewal survey are given in Ch 3, Sec 3 for all yachts.

16.2.2 Additional survey requirements are given in NR500 for yachts with additional service feature **C** or **W** or **A**.

17 Semi-submersible cargo ship

17.1 Annual survey

17.1.1 The survey is to include a general examination and testing, where appropriate, of the following items, as applicable:

- watertightness of immersed parts on the open deck and buoyancy towers up to the maximum submerged draft

- ballast system, including:
 - tank level gauges
 - remote valves and position status indicator in the central ballast station
 - remote pumps and status indicator in the central ballast station
 - alarms of the overflow tank
 - air pipe and fittings
 - means to prevent overpressure for pressurized ballast tanks
 - other examination and testing as per the Planned Maintenance System
- means of communication between the central ballast control system and:
 - ballast pump room
 - bridge
 - dynamic positioning control stand, when relevant
- draft mark automatic gauging system up to a representative submerged draft
- draft marks on the ship's hull up to the maximum submerged draft
- on-board stability software including:
 - special procedure when cargo is considered buoyant
 - interface with the tank level gauging system
- submersion operating manual
- ship's records and logbooks
- navigational and communication equipment, visibility and habitability, in case a secondary look-out point has been fitted.

17.2 Intermediate survey

17.2.1 The survey is to include:

- examination and thickness measurements of the submerged area, as deemed necessary by the Surveyor
- examination of critical areas of the structure, such as internal connection of the buoyancy towers, including thickness measurements and non-destructive examination, as deemed necessary. When the connection is bolted, a representative number of bolts are to be dismantled, to the satisfaction of the attending Surveyor

- internal examination of representative ballast tanks in buoyancy towers, when applicable, and thickness measurement, as deemed necessary.

Note 1: Note: If such examinations reveal no visible structural defects, the examination may be limited to a verification that the corrosion prevention system remains effective.

17.3 Class renewal survey

17.3.1 In addition to the requirements for annual survey, the renewal survey is to include:

- examination and thickness measurements, as deemed necessary by the attending Surveyor, of submerged shell above summer waterline
- examination and thickness measurements, including non-destructive examination if required, of critical areas of the structure such as buoyancy towers connection with hull or other critical areas, as found necessary by the Surveyor
- testing of submersion operation to a representative submerged draft.

18 Diving systems

18.1 Surveys

18.1.1 For survey requirements, refer to Chapter 4 of NR610, Rules for the Classification of Diving Systems.

19 Pipe laying ship

19.1 Annual survey

19.1.1 The annual survey is to include:

- verification of the presence onboard of the operating manual as defined in Pt E, Ch 12, Sec 1
- inspection of the structural arrangement and scantlings of the foundations of the pipe laying equipment.

19.2 Class renewal survey

19.2.1 In addition to the requirements of annual survey, the class renewal survey is to include:

- load tests in accordance with the pipe laying equipment testing program.

SECTION 9

SHIPS USING LOW FLASHPOINT LIQUID OR GAS FUELS

1 General

1.1 Application

1.1.1 The requirements of this Section apply to all self-propelled ships, other than those covered by Ch 4, Sec 5, which utilize gas or other low flash points fuels as a fuel for propulsion prime mover/auxiliary power generation arrangements and associated systems, or which have been assigned one of the following additional service features:

- **LNGfuel, CNGfuel, LPGfuel, methanolfuel, ammoniafuel and LFPfuel**

Note 1: these additional service features are always completed by **singlefuel** or **dualfuel** as defined in Ch 1, Sec 2, [4.13].

- **fuelcell**

1.1.2 These requirements are in addition to those laid down in Ch 3, Sec 1, [3.2.1], Ch 3, Sec 3, [3.1.1], Ch 3, Sec 3, [3.2.3], and Ch 3, Sec 6 as applicable.

These survey requirements do not cover fire protection, fire-fighting installation, and personnel protection equipment.

2 Annual survey - Hull items

2.1 General

2.1.1 The following requirements are to be verified during the survey of the fuel storage, fuel bunkering system and fuel supply system.

2.1.2 The logbooks and operating records are to be examined with regard to correct functioning of the gas detection systems, fuel supply/gas systems, etc. The hours per day of the reliquefaction plant, gas combustion unit, as applicable, the boil-off rate, and nitrogen consumption (for membrane containment systems) are to be considered together with gas detection records.

2.1.3 The manufacturer/builder instructions and manuals covering the operations, safety and maintenance requirements and occupational health hazards relevant to fuel storage, fuel bunkering, and fuel supply and associated systems for the used of the fuel, are to be confirmed as being aboard the vessel.

2.2 Gas related spaces, fuel preparation and handling rooms and piping

2.2.1 The survey is to include:

- examination of portable and fixed drip trays and insulation for the protection of the ship's structure in the event of a leakage
- examination of electrical bonding arrangements in hazardous areas, including bonded straps where fitted.

2.3 Fuel storage, bunkering and supply systems

2.3.1 The following requirements are to be examined, so far as applicable. Insulation need not to be removed, but any deterioration or evidence of dampness is to be investigated.

2.3.2 For fuel storage, the survey is to include:

- external examination of the storage tanks including secondary barrier if fitted and accessible
- general examination of the fuel storage hold place
- internal examination of tank connection space
- external examination of tank and relief valves
- verification of satisfactory operation of tank monitoring system
- examination and testing of installed bilge alarms and means of drainage of the compartment
- testing of the remote and local closing of the installed main tank valve.

2.3.3 For fuel bunkering system, the survey is to include:

- examination of bunkering stations and the fuel bunkering system
- verification of the satisfactory operation of the fuel bunkering control, monitoring and shutdown systems.

2.3.4 For fuel supply system, during working condition as far as practicable, the survey is to include:

- verification of the satisfactory operation of the fuel supply system control, monitoring and shutdown systems
- testing of the remote and local closing of the master fuel valve for each engine compartment.

3 Annual survey - Gas fuel machinery items

3.1 Control, monitoring and safety systems

3.1.1 The survey is to include:

- confirmation that gas detection and other leakage detection equipment in compartments containing fuel storage, fuel bunkering, and fuel supply equipment or components or associated systems, including indicators and alarms are in satisfactory operating condition
- verification that recalibration of the gas detection systems is done in accordance with the manufacturer's recommendations.
- verification of the satisfactory operation of the control, monitoring and automatic shutdown systems as far as practicable of the fuel supply and bunkering systems
- operational test, as far as practicable, of the shutdown of ESD protected machinery spaces.

3.2 Fuel handling piping, machinery and equipment

3.2.1 The survey is to include:

- examination, as far as practicable, of piping, hoses, emergency shutdown valves, relief valves, machinery and equipment for fuel storage, fuel bunkering, and fuel supply such as venting, compressing, refrigerating, liquefying, heating, cooling or otherwise handling the fuel
- examination of the means for inerting
- confirmation, as far as practicable, of the stopping of pumps and compressors upon emergency shutdown of the system.

3.3 Ventilating systems

3.3.1 The survey is to include:

- examination of the ventilation system, including portable ventilating equipment where fitted, is to be made for spaces containing fuel storage, fuel bunkering, and fuel supply units or components or associated systems, including air locks, pump rooms, compressor rooms, fuel preparation rooms, fuel valve rooms, control rooms and spaces containing gas burning equipment
- operational test, as far as practicable, of alarms, such as differential pressure and loss of pressure, where fitted.

3.4 Hazardous areas

3.4.1 The survey is to include:

- examination of electrical equipment and bulkhead/deck penetrations including access openings in hazardous areas, for continued suitability for their intended service and installation area.

4 Intermediate survey

4.1 General

4.1.1 In addition to the applicable requirements of the annual surveys, the intermediate survey is also to include:

- random test of gas detectors, temperature sensors, pressure sensors, level indicators, and other equipment providing input to the fuel safety system, to confirm their satisfactory operating condition
- verification of the proper response of the fuel safety system upon fault conditions.

5 Class renewal survey - Hull items

5.1 General

5.1.1 The class renewal survey is to include, in addition to the requirements of the annual surveys, examinations, tests and checks of sufficient extent to ensure that the fuel installations are in satisfactory condition and fit for intended purpose for the new period of class to be assigned, subject to proper maintenance and operation and to periodical surveys being carried out at the due dates.

5.2 Fuel handling and piping

5.2.1 All piping for fuel storage, fuel bunkering, and fuel supply such as venting, compressing, refrigerating, liquefying, heating, storing, burning or otherwise handling the fuel and liquid nitrogen installations are to be examined.

5.2.2 Removal of insulation from the piping and opening for examination may be required.

5.2.3 Where deemed suspect, a hydrostatic test to 1,25 times the maximum allowable relief valve setting (MARVS) for the pipeline is to be carried out.

5.2.4 After reassembly, the complete piping is to be tested for leaks.

5.2.5 Where water cannot be tolerated and the piping cannot be dried prior to putting the system into service, the surveyor may accept alternative fluids or alternative means of testing.

5.3 Fuel valves

5.3.1 All emergency shutdown valves, check valves, block and bleed valves, master gas valves, remote operating valves, isolating valves for pressure relief valves in the fuel storage, fuel bunkering, and fuel supply piping systems are to be examined and proven operable.

5.3.2 A random selection of valves is to be opened for examination.

5.4 Pressure relief valves

5.4.1 Fuel storage tank pressure relief valves

The survey is to include:

- opening for examination, adjustment and function test of the pressure relief valves for the fuel storage tanks
- if the tanks are equipped with relief valves with non-metallic membranes in the main or pilot valves, replacement of such non-metallic membranes.

5.4.2 Fuel supply and bunkering piping pressure relief valves

The survey is to include:

- opening for examination, adjustment and function test of pressure relief valves for the fuel supply and bunkering piping
- where a proper record of continuous overhaul and retesting of individually identifiable relief valves is maintained, consideration will be given to acceptance on the basis of opening, internal examination, and testing of a representative sampling of valves, including each size and type of liquefied gas or vapor relief valve in use, provided there is logbook evidence that the remaining valves have been overhauled and tested since crediting the previous class renewal survey.

5.4.3 Pressure/vacuum relief valves

The survey is to include:

- opening, examination, test and readjustment as necessary, depending on their design, of the pressure/vacuum relief valves, rupture disc and other pressure relief devices for interbarrier spaces and hold spaces.

5.5 Fuel storage tanks

5.5.1 Fuel storage tanks are to be examined in accordance with an approved survey plan.

5.5.2 Liquefied gas fuel storage tanks are to be examined based on a survey/inspection plan, in which requirements for the survey of liquefied gas fuel containment systems are to be in accordance with the requirements laid down in Ch 4, Sec 5, [6.7] and Ch 4, Sec 5, [6.8.4], except as noted below:

- the tank insulation and tank support arrangements shall be visually examined. Non-destructive testing may be required if conditions raise doubt to the structural integrity

- vacuum insulated independent fuel storage tanks of type C without access openings need not be examined internally. Where fitted, the vacuum monitoring system shall be examined and records should be reviewed.

6 Class renewal survey - Gas fuel machinery items

6.1 Fuel handling equipment

6.1.1 Fuel pumps, compressors, process pressure vessels, inert gas generators, heat exchangers and other components used in connection with fuel handling are to be examined according to the requirement of Part A, Chapter 3 or Ch 4, Sec 3, [7.3], as applicable.

6.2 Electrical equipment

6.2.1 The survey is to include:

- examination of electrical equipment to include the physical condition of electrical cables and supports, intrinsically safe, explosion proof, or increased features of electrical equipment
- function testing of pressurized equipment and associated alarms
- testing of systems for de-energizing electrical equipment which is not certified for use in hazardous areas
- electrical insulation resistance test of the circuit terminating in, or passing through, the hazardous zones and spaces is to be carried out.

6.3 Safety systems

6.3.1 Gas detectors, temperature sensors, pressure sensors, level indicators, and other equipment providing input to the fuel safety system are to be tested to confirm satisfactory operating condition.

6.3.2 Proper response of the fuel safety system upon fault conditions is to be verified.

6.3.3 Pressure, temperature and level indicating equipment are to be calibrated in accordance with the manufacturer's requirements.

APPENDIX 1 OIL TANKER LONGITUDINAL STRENGTH ASSESSMENT

1 General

1.1

1.1.1 The criteria indicated in this Appendix are to be used for the evaluation of longitudinal strength of the ship's hull girder as required by Ch 4, Sec 3, [1.3.2].

1.1.2 In order that ship's longitudinal strength to be evaluated can be recognized as valid, fillet welding between longitudinal internal members and hull envelopes are to be in sound condition so as to keep integrity of longitudinal internal members with hull envelopes.

2 Evaluation of longitudinal strength

2.1 Transverse sectional areas

2.1.1 The transverse sectional areas of deck flange (deck plating and deck longitudinals) and bottom flange (bottom shell plating and bottom longitudinals) of the ship's hull girder are to be calculated by using the thickness measured, renewed or reinforced, as appropriate, during the class renewal survey.

2.1.2 If the diminution of sectional areas of either deck or bottom flange exceeds 10% of their respective as-built area (i.e. original sectional area when the ship was built), either one of the following measures is to be taken:

- a) to renew or reinforce the deck or bottom flanges so that the actual sectional area is not less than 90% of the as-built area; or
- b) to calculate the actual section moduli (Z_{act}) of transverse section of the ship's hull girder by applying the calculation method specified in [2.3], by using the thickness measured, renewed or reinforced, as appropriate, during the class renewal survey.

2.2 Transverse section modulus

2.2.1 The actual section modulus (Z_{act}) of the transverse section of the ship's hull girder calculated in accordance with item b) of [2.1.2] is not to be less than 90% of the required section modulus for new buildings $Z_{R, MIN}$ or Z_R , whichever is the greater, specified in Pt B, Ch 6, Sec 2, [4.2].

2.3 Calculation criteria of section modulus

2.3.1 When calculating the transverse section modulus of the ship's hull girder, the requirements under Pt B, Ch 6, Sec 1, [2] should be applied.

3 Sampling method of thickness measurements

3.1 Extent of evaluation

3.1.1 Longitudinal strength should be evaluated within 0,4L amidships for the extent of the hull girder length that contains tanks therein and within 0,5L amidships for adjacent tanks which may extend beyond 0,4L amidships where tanks means ballast tanks and cargo tanks.

3.2 Sampling method of thickness measurements

3.2.1 Transverse sections should be chosen such that thickness measurements can be taken for as many different tanks in corrosive environment as possible, e.g. ballast tanks sharing a common plane boundary with cargo tanks fitted with heating coils, other ballast tanks, cargo tanks permitted to be filled with sea water and other cargo tanks. Ballast tanks sharing a common plane boundary with cargo tanks fitted with heating coils and cargo tanks permitted to be filled with sea water should be selected where present.

3.2.2 The minimum number of transverse sections to be sampled should be in accordance with the requirements for the current class renewal survey. The transverse sections should be located where the largest thickness reductions are suspected to occur or are revealed from deck and bottom plating measurements required in Ch 4, Sec 3, Tab 5 and should be clear of areas which have been locally renewed or reinforced.

3.2.3 At least two points should be measured on each deck plate and/or bottom shell plate required to be measured within the cargo area in accordance with the requirements for the current class renewal survey.

3.2.4 Within 0,1 D (where D is the ship's moulded depth) of the deck and the bottom at each transverse section to be measured, every longitudinal and girder should be measured on the web and face plate, and every plate should be measured at one point between longitudinals.

3.2.5 For longitudinal members other than those specified in [3.2.4] to be measured at each transverse section, every longitudinal and girder should be measured on the web and face plate, and every plate should be measured at least in one point per strake.

3.2.6 The thickness of each component should be determined by averaging all of the measurements in way of the transverse section on each component.

3.3 Additional measurements

3.3.1 Where one or more of the transverse sections are found to be deficient in respect of the longitudinal strength requirements given in this Appendix, the number of transverse sections for thickness measurements should be increased such that each tank within the 0,5L amidships region has been sampled. Tank spaces that are partially within, but extend beyond, the 0,5 L region should be sampled.

3.3.2 Additional thickness measurements should also be performed on one transverse section forward and one aft of each repaired area to the extent necessary to ensure that the areas bordering the repaired section also comply with the requirements of this Appendix.

3.4 Repair methods

3.4.1 The extent of renewal or reinforcement carried out to comply with this Appendix should be in accordance with [3.4.2].

3.4.2 The minimum continuous length of a renewed or reinforced structural member should be not less than twice the spacing of the primary members in way. In addition, the thickness diminution in way of the butt joint of each joining member forward and aft of the replaced member (plates, stiffeners, girder webs and flanges, etc.) should not be within the substantial corrosion range (75% of the allowa-

ble diminution associated with each particular member). Where differences in thickness at the butt joint exceed 15% of the lower thickness, a transition taper should be provided.

3.4.3 Alternative repair methods involving the fitting of straps or structural member modification should be subject to special consideration. In considering the fitting of straps, it should be limited to the following conditions:

- to restore and/or increase longitudinal strength;
- the thickness diminution of the deck or bottom plating to be reinforced should not be within the substantial corrosion range (75% of the allowable diminution associated with the deck plating)
- the alignment and arrangement, including the termination of the straps, is in accordance with a standard recognized by the Society
- the straps are continuous over the entire 0,5 L amidships length; and
- continuous fillet welding and full penetration welds are used at butt welding and, depending on the width of the strap, slot welds. The welding procedures applied must be acceptable to the Society.

3.4.4 The existing structure adjacent to replacement areas and in conjunction with the fitted straps should be capable of withstanding the applied loads, taking into account the buckling resistance and the condition of welds between the longitudinal members and hull envelope plating.

Part A
Classification and Surveys

Chapter 5

**SCOPE OF SURVEYS RELATED TO
ADDITIONAL CLASS NOTATIONS**

SECTION 1	GENERAL
SECTION 2	VERISTAR AND STAR NOTATIONS
SECTION 3	AVAILABILITY OF MACHINERY
SECTION 4	AUTOMATED MACHINERY SYSTEMS
SECTION 5	INTEGRATED SHIP SYSTEMS
SECTION 6	MONITORING EQUIPMENT
SECTION 7	POLLUTION PREVENTION
SECTION 8	REFRIGERATING INSTALLATIONS
SECTION 9	ARRANGEMENTS FOR NAVIGATION IN ICE
SECTION 10	OTHER NOTATIONS

SECTION 1 GENERAL

1 General

1.1

1.1.1 The purpose of this Chapter is to give details on the scope of surveys of specific equipment and systems fitted on board the ship, which are covered by an additional class notation. Unless otherwise specified in Ch 1, Sec 2, [6], the scope of these surveys provides the requirements to be complied with for the maintenance of the relevant additional class notation.

1.1.2 These specific requirements are additional to those laid down in Part A, Chapter 3 and Part A, Chapter 4. These surveys are to be carried out at intervals as described in Ch 2, Sec 2, as far as possible concurrently with the surveys of the same type, i.e. annual, intermediate or class renewal survey.

1.1.3 The equipment and systems are also to be submitted to occasional survey whenever one of the cases indicated in Ch 2, Sec 2, [6] occurs.

1.1.4 Where specific requirements are given for the class renewal survey, they are additional to the requirements for

the annual survey, which, in accordance with Ch 3, Sec 3, [1.1.7], is to be carried out at the completion of the class renewal survey.

1.1.5 For the assignment of the additional class notations, ships are to be submitted to an admission to class survey as described in Ch 2, Sec 1, [2] and Ch 2, Sec 1, [3] for new and existing installations, respectively, as applicable.

2 Additional class notations subject to additional surveys

2.1

2.1.1 The specific requirements detailed in this Chapter are linked to the additional class notation(s) assigned to the ship. Where a ship has more than one additional class notation, the specific requirements linked to each additional class notation are applicable as long as they are not contradictory.

2.1.2 Tab 1 indicates which additional class notations are subject to specific requirements, and in which Section and/or Article they are specified.

Table 1 : Additional class notations for which specific survey requirements are applicable

Additional class notation	Section or Article applicable in this Chapter	Type of surveys affected by these specific requirements	Remarks
STAR-HULL VeriSTAR-HULL SIS STAR-MACH SIS	Ch 5, Sec 2	class renewal survey annual audits	
Availability of machinery: AVM-APS AVM-DPS AVM-IPS AVM-FIRE	Ch 5, Sec 3	annual survey class renewal survey	
Automated machinery systems: AUT-UMS AUT-CCS AUT-PORT AUT-IMS	Ch 5, Sec 4	annual survey class renewal survey	
Integrated ship systems: SYS-NEQ SYS-NEQ-1 SYS-COM SYS-IBS SYS-IBS-1	Ch 5, Sec 5	annual survey class renewal survey	
Monitoring equipment: MON-HULL MON-SHAFT MON-ICE L(i), MON-ICE G	Ch 5, Sec 6	annual survey class renewal survey tailshaft survey	

Additional class notation	Section or Article applicable in this Chapter	Type of surveys affected by these specific requirements	Remarks
Pollution prevention: CLEANSHIP, CLEANSHIP SUPER AWT-A, AWT-B, AWT-A/B BWE BWT GWT NDO-x days NOX-x% OWS-x ppm SOX-x% EGCS-SCRUBBER SEEMP ULEV CEMS	Ch 5, Sec 7	annual survey intermediate survey class renewal survey	
Refrigerating installations: REF-CARGO REF-CONT REF-STORE	Ch 5, Sec 8	annual survey class renewal survey	
Navigation in ice environment: ICE ICE CLASS IA SUPER, ICE CLASS IA, ICE CLASS IB, ICE CLASS IC, ICE CLASS ID YOUNG ICE 1, YOUNG ICE 2	Ch 5, Sec 9	class renewal survey	
Other notations: ACCESS BATTERY SYSTEM BIORISK MANAGED, BIORISK SECURED CARGOCONTROL CBRN, CBRN-WASHDOWN COLD DI COLD (H t_{DH}, E t_{DE}) COLD CARGO COMF-NOISE-SIS, COMF-NOISE-Pax-SIS, COMF-NOISE-Crew-SIS COMF-VIB-SIS, COMF-VIB-Pax-SIS, COMF-VIB-Crew-SIS COMF+-SIS COVENT CYBER MANAGED, CYBER SECURE DYNAPOS ECFP ELECTRIC HYBRID GRABLOADING GRAB [X] HABITABILITY HEADING CONTROL HEL HYBRID MECHANICAL PROPULSION OAS OHS SPM STRENGTHBOTTOM VCS EFP-M, EFP-AMC	Ch 5, Sec 10	as applicable in accordance with the related Articles in Ch 5, Sec 10	

SECTION 2

VERiSTAR AND STAR NOTATIONS

1 General

1.1 Application

1.1.1 The requirements of this Section apply to ships which have been assigned one of the following additional class notations related to the **VeriSTAR** system, as described in Ch 1, Sec 2, [6.2]:

STAR-HULL

VeriSTAR-HULL SIS

STAR-MACH SIS

2 VeriSTAR-HULL SIS

2.1 General

2.1.1 As indicated in Pt F, Ch 1, Sec 1, the additional class notation **VeriSTAR-HULL SIS** is assigned at the design stage or after construction, and maintained during the service life, to ships complying with the requirements of Ch 1, Sec 2, [6.2.2] and Ch 1, Sec 2, [6.2.3].

2.1.2 The additional class notation **VeriSTAR-HULL SIS** is assigned to a ship in order to reflect the following:

- a structural tridimensional analysis has been performed for the hull structures, as defined in Pt B, Ch 7, App 1 or Pt B, Ch 7, App 2 or Pt B, Ch 7, App 3, as applicable
- the hull structure condition is periodically assessed, usually at the class renewal survey, using the results of the inspections and thickness measurements performed during the survey. The results of this assessment are made available to the Owner.

2.1.3 The following is to be available on board:

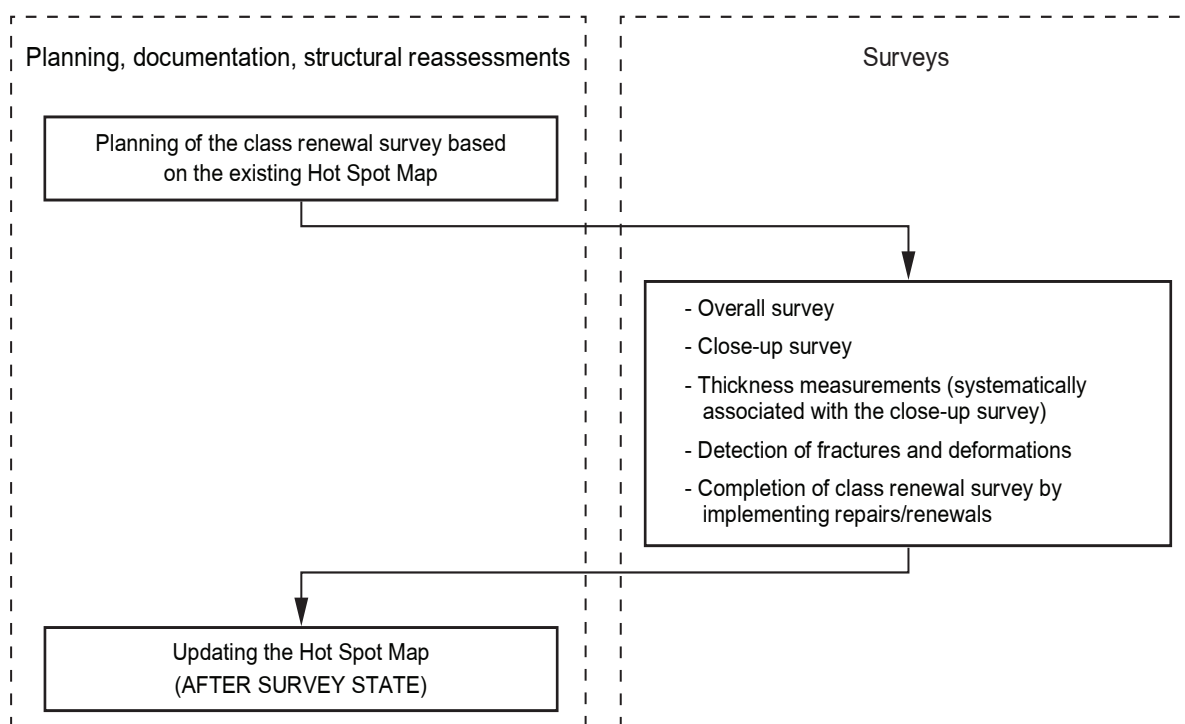
- the class renewal survey report
- the results of the periodical structural reassessments done after each class renewal survey
- the Society's requirements for structural repairs and renewals
- the hot spot map of the structure.

2.2 Class renewal survey

2.2.1 The survey for the renewal of the **VeriSTAR-HULL SIS** notation is to be carried out concurrently with the class renewal survey.

The documentation to be prepared, the surveys to be carried out and the structural reassessment to be done in connection with the class renewal survey are summarized in the flowchart shown in Fig 1.

Figure 1 : Actions to be taken in connection with the class renewal survey (VeriSTAR-HULL SIS)



2.2.2 In addition to the scope of the class renewal survey as required for the ship concerned, additional thickness measurements and surveys may be required by the Society taking into account the surveys, thickness measurements and a specific survey for fatigue fracture detection carried out as a result of the previous hot spot map.

2.2.3 Once the renewal survey is completed to the Society satisfaction, the “after survey” hot spot map is prepared and submitted to the Society.

3 STAR-HULL

3.1 General

3.1.1 As indicated in Pt F, Ch 1, Sec 2, the additional class notation **STAR-HULL** is assigned to a ship in order to reflect the fact that a procedure including periodical and corrective maintenance, as well as periodical and occasional inspections of hull structures and equipment, (hereafter referred to as the Inspection and Maintenance Plan - IMP) are dealt with on board by the crew and at the Owner’s offices.

The assignment of the notation implies that a structural tridimensional analysis has been performed for the hull structures, as defined in Pt B, Ch 7, App 1 or Pt B, Ch 7, App 2 or Pt B, Ch 7, App 3, as applicable.

The implementation of the Inspection and Maintenance Plan is surveyed by the Society through periodical check of the hull structure, normally at the class renewal survey, against defined acceptance criteria and based on:

- the collected data from actual implementation of the Inspection and Maintenance Plan
- the results of the inspections, thickness measurements and other checks carried out during the class renewal survey.

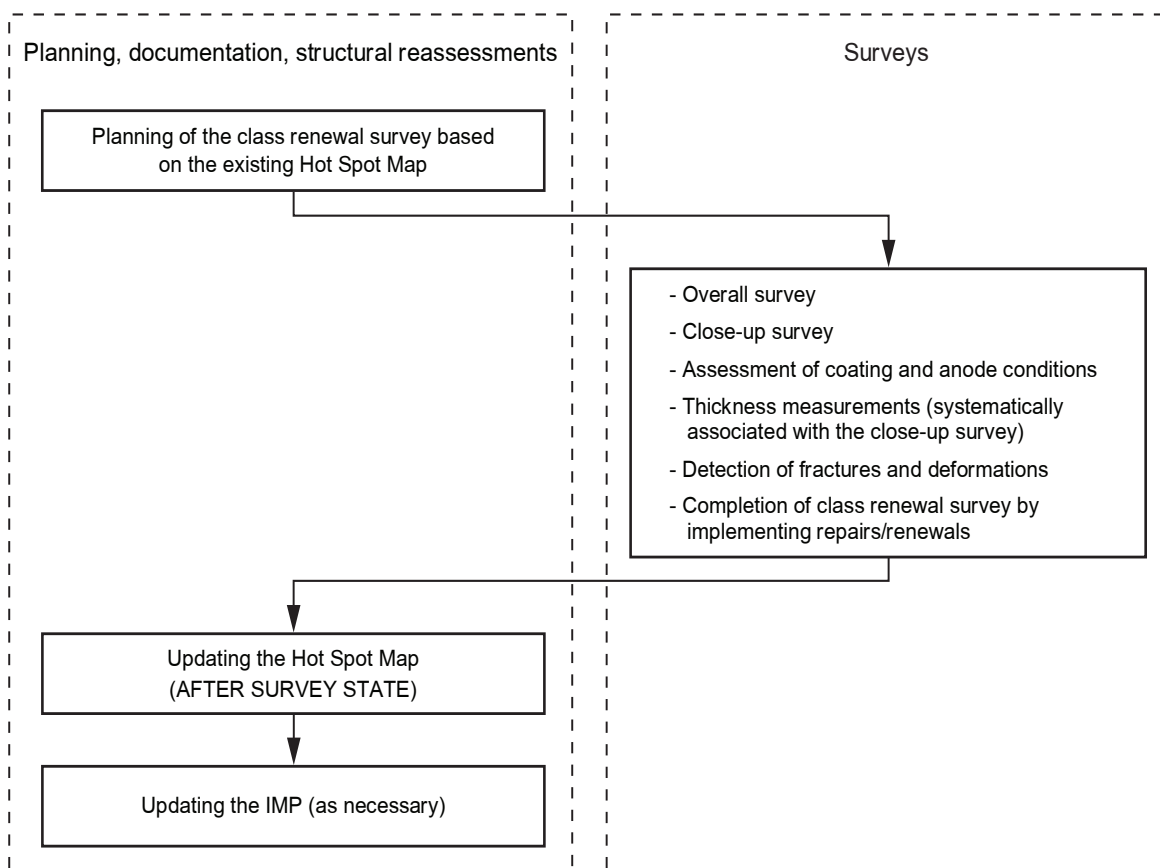
3.2 Class renewal survey

3.2.1 In addition to the scope of the class renewal survey as required for the ship concerned (see Fig 2), the following is to be carried out:

- the assessment of the condition of coating and anodes
- additional thickness measurements and surveys may be required by the Society
- a specific survey for fatigue fracture detection as a result of the previous hot spot map.

3.2.2 Once the renewal survey is completed to the Society satisfaction, the “after survey” hot spot map is to be prepared and submitted to the Society, as well as the Inspection and Maintenance Plan, updated as needed.

Figure 2 : Actions to be taken in connection with the class renewal survey (STAR-HULL)



3.3 Suspension and withdrawal of the notation

3.3.1 The maintenance of the **STAR-HULL** notation is subject to the same principles as those for the maintenance of class: surveys are to be carried out by their limit dates and possible conditions of class (related to the notation) are to be dealt with by their limit dates.

The suspension of class automatically causes the suspension of the **STAR-HULL** notation.

3.3.2 Various events may lead either to imposition of a condition of class related to the **STAR-HULL** notation or to suspension of the notation itself. Some cases are given below.

- The condition of the ship is below the minimum level required for class (e.g. scantling of a hull structure below the corrosion margin). The action to be taken is either the immediate repair or the imposition of a condition of class for the class (if acceptable) and suspension of the **STAR-HULL** notation. However, in cases where the condition of class is of a minor nature, the notation may not be suspended.
- The condition of the ship is below the minimum level for the **STAR-HULL** notation, but still above the level for the class (e.g. the scantling of a hull structure is below the corrosion margin acceptable for the notation but is still above the corrosion margin). The action to be taken is either the immediate repair or the imposition of a condition of class for the **STAR-HULL** notation (without condition of class for class).
- The Inspection and Maintenance Plan is not complied with (e.g. delays in performing the operations programmed according to the plan or the scope of inspection and/or maintenance not completely fulfilled).

The action to be taken is:

- either the immediate compliance with the requirements or the imposition of a condition of class if the non-conformity is of a minor nature or is an exceptional occurrence
- or the suspension of the **STAR-HULL** notation if the non-conformity is of a major nature or a recurrence.
- A defect or a deficiency is found in applying the IMP. The actions to be taken are the same as stated both for repair of structure/coating/equipment (first two cases above) and for the application of the IMP (third case above).
- An unexpected defect or deficiency is found or an accident occurs, i.e. not as a result of lack of maintenance or failure in the application of the IMP. The actions to be taken are the same as stated for repair of structure/coating/equipment (first two cases above).

3.3.3 The withdrawal of the **STAR-HULL** notation may be decided in different cases, such as:

- recurrent suspension of the **STAR-HULL** notation
- suspension of the **STAR-HULL** notation for more than a given period (i.e. 3 months)
- expiry or withdrawal of class.

4 STAR-MACH SIS

4.1 General

4.1.1 The additional class notation **STAR-MACH SIS**, as described in Ch 1, Sec 2, [6.2.6], is assigned as per the requirements of Pt F, Ch 1, Sec 3. The present Article gives requirements for the maintenance of this notation.

4.1.2 The Maintenance Plan based on a risk analysis shall be dynamic and subject to a continuous improvement process. The Operator is to collect, analyse, review and react to equipment historical data throughout the ship operating life in order to tune the Maintenance Plan accordingly.

4.2 Annual audit and confirmatory surveys

4.2.1 The annual shipboard audit and confirmatory surveys are to be carried out in conjunction with the annual survey and in accordance with the requirements of Ch 2, App 1, [5.2].

The scope of this audit and of the confirmatory surveys is to include the ship's items which are covered by the notation in addition to the PMS machinery items.

4.3 Re-approval of the Maintenance Plan

4.3.1 Once in each five year class period, on receipt of the documents listed in [4.3.2], the Society performs a documentation technical review of the elements demonstrating a continuous improvement process of the risk analysis, including the updated maintenance plan, as described in Pt F, Ch 1, Sec 3, [2.2.2], in order to re-approve the maintenance plan.

On a case by case basis, if the risk analysis update is not documented, the Society can update the risk analysis, based on the submitted documentation, in order to re-approve the maintenance plan.

4.3.2 The following documentation is to be submitted to the Society for review:

- Methodology for continuous improvement / tuning of the Reliability Centred Maintenance (RCM) study
- Note 1: See Pt F, Ch 1, Sec 3, [1.2] for the definition of RCM.
- Any modification or update in the RCM study documents since the last Maintenance Plan approval, see Pt F, Ch 1, Sec 3, [2.1.1]
 - Any modification of the systems design since the last Maintenance Plan approval, see Pt F, Ch 1, Sec 3, [2.1.2]
 - Any modification of the ship operation since the last Maintenance Plan approval
 - Any modification of the Maintenance Plan since its last approval, including information detailed in Pt F, Ch 1, Sec 3, [2.1.3]
 - Available historical data since the last Maintenance Plan approval, see Pt F, Ch 1, Sec 3, [2.1.4].

4.3.3 If the Maintenance Plan is not re-approved in due time in order to maintain the **STAR-MACH SIS** notation for the class certificate renewal, the **STAR-MACH SIS** notation will be converted in **STAR-MACH** notation.

SECTION 3

AVAILABILITY OF MACHINERY

1 General

1.1

1.1.1 The requirements of this Section apply to ships which have been assigned one of the following additional class notations related to availability of machinery, as described in Ch 1, Sec 2, [6.3]:

AVM-APS

AVM-DPS

AVM-IPS

AVM-FIRE

2 Annual survey

2.1

2.1.1 At each annual survey the Owner or his representative is to declare to the attending Surveyor that no modifications have been made to the systems affecting the notations without prior approval by the Society.

3 Class renewal survey

3.1

3.1.1 At each class renewal survey a test is to be conducted in order to ascertain that the systems affecting the notations operate satisfactorily. This test is usually to be carried out during sea trials.

SECTION 4

AUTOMATED MACHINERY SYSTEMS

1 General

1.1

1.1.1 The requirements of this Section apply to ships which have been assigned one of the following additional class notations related to automated machinery systems, as described in Ch 1, Sec 2, [6.4]:

AUT-UMS

AUT-CCS

AUT-PORT

AUT-IMS

2 Annual survey

2.1

2.1.1 The Owner or his representative is to declare to the attending Surveyor that no significant modifications have been made without prior approval by the Society.

2.1.2 The annual survey is to include:

- a general examination of the control systems covered by the notation, including a random check of the proper operation and calibration of main measuring, monitoring, alarm, and automatic shut-off devices
- a check of the fire detectors
- a check of the bilge flooding alarms
- a running test which may be also performed by a spot check method.

3 Class renewal survey

3.1

3.1.1 The requirements given in Article [2] for annual survey are to be complied with.

An additional program of examinations, checks and tests is to be devised in agreement with the Owner and based on the operational data and experience of previous surveys. This program is to include verification of the calibration of instruments, testing of control and safety functions of the machinery and black-out test. The Owner is to produce evidence that all these checks and tests have been carried out and this will be verified by the Surveyor at random.

In addition, the proper operation of the control system of propulsion machinery is to be checked during sea trials.

SECTION 5

INTEGRATED SHIP SYSTEMS

1 General

1.1

1.1.1 The requirements of this Section apply to ships which have been assigned one of the following additional class notations related to integrated ship systems, as described in Ch 1, Sec 2, [6.5]:

SYS-NEQ

SYS-NEQ-1

SYS-COM

SYS-IBS

SYS-IBS-1

2 Annual survey

2.1 All notations

2.1.1 The Owner or his representative is to declare to the attending Surveyor that no significant modifications have been made to the relevant installations without the prior approval by the Society.

An examination of the log-books is to be carried out to verify the proper operation of systems in the period subsequent to the last survey and measures taken to avoid repetition of any malfunctions or failures which have occurred during the same period.

2.2 Notations SYS-NEQ and SYS-NEQ-1

2.2.1 The annual survey is to include:

a) general:

- general examination of the bridge layout, with regard to the field of vision, window wipe and wash system, wheelhouse lighting and heating/cooling systems, and arrangements for the safety of navigators

b) propulsion and steering controls:

- test of the steering gear to confirm the proper operation of the various remote controls from the wheelhouse
- test, as far as practicable, of the propulsion control, including propeller pitch control, where fitted
- check of the relevant indicators such as rudder angle, ahead/astern position, propeller rpm or pitch

c) navigation aids:

- test of the satisfactory operating condition of radars
- test of the functions available at quay side of the ARPA and collision avoidance system
- test of the position fixing system
- test of the gyro compass system
- test of the echo sounding device, using appropriate scale of depth
- test of other available alarms (sounding equipment, self-checking device, etc.), as far as practicable

d) communications:

- test of the whistle control device from the relevant workstation
- check of the different communication systems (internal communication, VHF radiotelephone installation, NAVTEX)

e) bridge safety and alarm system (notation **SYS-NEQ-1**)

- test, as far as practicable, of the vigilance system and related alarm/warning transfer system.

2.3 Notation SYS-COM

2.3.1 The annual survey is to include a check of the means of transmission (hardware and software) as follows:

a) compliance of the environmental conditions of use of the components (such as temperature, power supply) with those for which they were approved

b) verification of the correct installation on board, including hardware (cabling, location of aerial, layout of console) and software (such as software version, software registry, compatibility of assembled software, man machine interface)

c) verification by means of an appropriate test of the proper function of:

- the internal communication between the different workstations, checking at random the availability of data
- the external communication with the shore; consideration may be given to recent records of such external communication from ship to shore and from shore to ship

d) verification of update policies description report, crisis management manual, security risk management process report.

2.4 Notations SYS-IBS and SYS-IBS-1

2.4.1 The annual survey is to include a check of the condition of the different workstations that belong to the IBS system, and a test, as far as practicable, of:

- the main functions of the IBS; in this respect, the examinations and tests given in [2.2.1] are to be carried out, where applicable
- the transitional and emergency sources required for the system and recovery of systems after restoring power
- the alarm and monitoring system in the wheelhouse, at random.

3 Class renewal survey

3.1 All notations

3.1.1 The requirements given in [2] for annual survey are to be complied with. An additional program of examinations, checks and tests is to be devised in agreement with the Owner and based on the operational data and experience of previous surveys. This program is to include verification of the calibration of instruments and testing of control and safety functions of the installation. An additional program of random tests of the systems is to be performed during sea trials.

The Owner is to confirm that any modification to the hardware and software is fully documented and properly recorded.

SECTION 6

MONITORING EQUIPMENT

1 General

1.1 Application

1.1.1 The requirements of this Section apply to ships which have been assigned one of the following additional class notations related to hull and tailshaft monitoring equipment, as described in Ch 1, Sec 2, [6.6]:

MON-HULL

MON-SHAFT

MON-ICE L(i)

MON-ICE G

2 MON-HULL

2.1 Annual and class renewal survey

2.1.1 The Owner or his representative is to declare to the attending Surveyor that the hull monitoring equipment has been recently calibrated using a reference loading case.

3 MON-SHAFT

3.1 Tailshaft survey

3.1.1 General

For ships fitted with either oil lubricated or water lubricated tailshaft bearings and assigned with the additional class notation **MON-SHAFT**, in addition to the conditions stated in Ch 2, Sec 2, [5.5.3] and the additional survey requirements stated in [3.1.2] and [3.1.3], the tailshaft need not be withdrawn at both the complete and the modified surveys, provided that all the condition monitoring data are found to be within the permissible limits and the remaining requirements for the respective surveys are complied with.

3.1.2 Requirements for oil lubricated tailshaft bearings

The scope of the requirements for the modified and complete surveys is specified in Ch 2, Sec 2, [5.5.3].

When the records of the tailshaft bearing temperature readings are checked and doubts arise, the Surveyor may require the verification of the accuracy of the gauging devices.

3.1.3 Requirements for water lubricated tailshaft bearings

In the scope of the applicable survey requirements specified in Ch 2, Sec 2, [5.5.3], the following additional requirements are to be fulfilled at modified survey, when applicable:

- verification of the aft bearing clearances
- examination of the endoscopic records and results
- external examination of the water pumping and filtering system and confirmation that such equipment operate satisfactorily
- examination of water analysis records (chloride content and presence of bearing material or other particles)
- verification of alarms (flow etc.) and interlock system.

4 MON-ICE L(i) and MON-ICE G

4.1 Annual survey

4.1.1 The Owner or his representative is to declare to the attending Surveyor that:

- all the components of the ice load monitoring system are able to ensure the main functions
- the ice load monitoring equipment has been calibrated complying with the declaration of the Manufacturer for the period and procedure of calibration.

SECTION 7

POLLUTION PREVENTION

1 General

1.1 Application

1.1.1 The requirements of this Section apply to ships which have been assigned one of the following additional class notations related to pollution prevention systems, as described in Ch 1, Sec 2, [6.8]:

- **CLEANSHIP**
- **CLEANSHIP SUPER**
- **AWT-A**
- **AWT-B**
- **AWT-A/B**
- **BWE**
- **BWT**
- **GWT**
- **NDO-x days**
- **NOX-x%**
- **OWS-x ppm**
- **SOX-x%**
- **EGCS-SCRUBBER**
- **SEEMP**
- **CEMS**
- **ULEV**

2 Prevention of sea pollution

2.1 First annual survey

2.1.1 Confirmation of no discharge period

During the first annual survey, the Surveyor collects the results of tests and measurements undertaken by the Shipowner according to Pt F, Ch 9, Sec 3. These results are used to confirm or modify the no discharge numeral appended to the notations **NDO-x days**.

2.1.2 Audit

An on-board audit of the procedures, as required in Part F, Chapter 9, is done by the Surveyor in order to ascertain that the Master and crew are familiar with the ship's on-board procedures for preventing pollution and in order to check that the discharge records mentioned in Part F, Chapter 9 are properly completed.

2.2 Annual survey

2.2.1 General

The survey is to include, as far as practicable:

- confirmation of the installation being in accordance with the plans. If modifications have been made, checking that these modifications are in accordance with approved documentation (for all additional class notations related to pollution prevention systems)
- confirmation that the IOPP certificate is valid (for **CLEANSHIP**, **CLEANSHIP SUPER** and **OWS-x ppm**)
- general examination of the most important components of the sewage treatment plant, the garbage treatment plant, the oil filtering equipment, the incinerators if fitted, the comminuters and grinders, the hazardous wastes recovery unit if fitted (for **CLEANSHIP** and **CLEANSHIP SUPER**)
- general examination of the holding tanks, including examination of a possible corrosion protection of the inside surfaces of the tanks which are to be in good condition (for **CLEANSHIP** and **CLEANSHIP SUPER**)
- verification of the satisfactory condition of the standard discharge connections for oil and wastewater (for **CLEANSHIP**, **CLEANSHIP SUPER**, **AWT-A**, **AWT-B**, **AWT-A/B** and **NDO-x days**)
- external examination and operating tests of the equipment and systems as required in Pt F, Ch 9, Sec 2 and Pt F, Ch 9, Sec 3 (for all additional class notations related to pollution prevention systems).
- confirmation that the hazardous wastes are properly stowed as specified in the garbage management plan (for **CLEANSHIP**, **CLEANSHIP SUPER** and **NDO-x days**).

For some pollution prevention system of [1.1.1], the survey is also to include, as far as practicable:

- ascertainment of the correct concentration of the disinfectant in the effluent (for **CLEANSHIP**, **CLEANSHIP SUPER**, **AWT-A**, **AWT-B**, **AWT-A/B** and **GWT**)
- ascertainment of possible concentration of other chemicals in the effluent (for **CLEANSHIP**, **CLEANSHIP SUPER**, **AWT-A**, **AWT-B**, **AWT-A/B** and **GWT**).

2.2.2 Review of records

The following records for the preceding 12 months are to be reviewed as necessary:

- oil record book (for **CLEANSHIP**, **CLEANSHIP SUPER** and **OWS-x ppm**)
- garbage record book (for **CLEANSHIP** and **CLEANSHIP SUPER**)
- records of ballast exchanges after international voyages (for **BWE** and **BWT**)
- ballast water record book (for **BWE** and **BWT**)
- sewage and grey water discharge book (for **CLEANSHIP**, **CLEANSHIP SUPER**, **GWT** and **AWT-A**, **AWT-B**, **AWT-A/B**)
- emissions record (for **CLEANSHIP SUPER**, **NOX-x%** and **SOX-x%**)

- results of the tests on effluents done by the Shipowner according to Pt F, Ch 9, Sec 4, [2.3.1] for any pollution prevention system of [1.1.1] (for **AWT-A**, **AWT-B**, **AWT-A/B**).

2.3 Class renewal survey

2.3.1 The requirements given in [2.2] for annual surveys are to be complied with. In addition, for all additional class notations related to pollution prevention systems, the following is to be carried out:

- demonstration, under working conditions, of the correct functions of the most important components of the sewage treatment plant or AWT plant if fitted, the garbage treatment plant, the oil filtering equipment, the incinerators if fitted, the comminuters and grinders, the hazardous waste recovery unit if fitted
- ascertainment of the correct function of the alarms.

3 Prevention of air pollution

3.1 Annual survey

3.1.1 Ozone depleting substances (CLEANSHIP, CLEANSHIP SUPER)

- A procedure for annual verification of the system and equipment condition by an authorised organisation is to be settled. The interval of this verification may be extended in case of predictive maintenance scheme approved by the Society.
- A procedure for weekly verification and maintenance is to be settled enabling to:
 - check the tightness of the circuits by satisfactory means (such as weighing or vessel pressure monitoring)
 - identify the location of possible leakage
 - carry out necessary corrective actions.

Record books tracing all the operations carried out on board the ship according to the procedures mentioned in the NOx Technical Code are to be kept on-board and updated after each intervention. They are to include in particular the following records:

- presence of leak and corrective action
- volume of substance recovered and indication of the storage location
- volume of substance recharged
- volume of substance consumed
- volume of substance disposed.

The survey is to include the following items:

- verification that the above procedures for annual and weekly checking of systems with ozone depleting substances are available on-board
 - confirmation that appropriate entries are being made in the record book for ozone depleting substances
 - test of the proper operation of the leak detectors and related audible and visual alarms
- c) Review of ozone - depleting substance record book.

3.1.2 NOx emission (CLEANSHIP SUPER, NOX-x%)

- The procedures for demonstrating compliance with NOx emission limits on board are given in the NOx Technical Code.
- During the annual survey, it is to be confirmed that the NOx emission control procedure is available on-board
- NOx emission records.

3.1.3 SOx emission (CLEANSHIP, CLEANSHIP SUPER, SOX-x%)

Procedures are to be established to detail the maximum sulphur content in the fuel oil purchase orders, and to check the actual content of sulphur at the delivery of bunker.

In the case the actual sulphur content is checked by sampling testing and analysis, procedures are to be carried out in accordance with a recognised standard acceptable to the Society.

The fuel management procedures are to be established and followed as part of the certified ship management system of the ship.

Records on purchase orders and on type of checking carried out, including results, are to be kept on-board.

The survey is to include the following items:

- verification that the above procedures for defining, ordering and checking fuel oils for control of SOx emission are available on-board
- confirmation that fuel oil sulphur content records are available on-board
- emission record (when exhaust gas cleaning is provided (EGC)).

3.1.4 Shipboard incineration (CLEANSHIP, CLEANSHIP SUPER)

The annual survey is to include the following items, when fitted:

- external examination of the incinerators and confirmation that such equipment operates satisfactorily
- test of the alarms, exhaust monitoring devices and emergency stop located outside the compartment.

3.1.5 Exhaust Gas Cleaning System-Scrubber (EGCS-SCRUBBER)

The annual survey is to include the following items, when fitted:

- examination of the logbooks with regard to correct functioning of the Exhaust Gas Cleaning Systems, emissions monitoring and washwater monitoring systems
- confirmation that the approved Operating and Maintenance Instruction Manual is onboard
- confirmation that the Instrumentation, Control, Monitoring, and Safety equipment of each system unit are operating satisfactorily
- examination of emergency shutdown or bypass valves, remote operating valves, and machinery and equipment associated with processing or distribution of exhaust gases and, as far as practicable, testing of the emergency shutdown of the system

- examination and functional test of all tanks, piping, hoses, pumps, strainers, separators, filtration units, dosing systems, and equipment associated with processing of washwater, injection of reductant or collection of exhaust residues
- examination of drip trays, overflow arrangements, shielding or insulation installed for the protection of personnel or of the ship
- examination of electrical equipment associated with the operation or monitoring of Exhaust Gas Cleaning Systems
- confirmation that Personal Protective Equipment (PPE) and facilities are available onboard and maintained in good conditions
- external examination of all components including scrubber units, of insulation, etc., including foundations and attachments
- confirmation of correct operation of all rotating and reciprocating components, such as exhaust gas fans, water treatment pumps, dry handling conveyors, ventilation fans
- verification of the correct operation of all remotely operated or automatically controlled valves in the exhaust, water treatment or dry handling systems
- examination of the Exhaust Gas Cleaning System during working condition. Multi-mode SO_x scrubbers are to be tested in all operational modes, as far as practicable.

3.2 Class renewal survey

3.2.1 The requirements given in [3.1] for annual surveys are to be complied with. In addition, the following is to be carried out:

- for **CLEANSHIP SUPER**, **NOX-x%** and **SOX-x%**, confirmation of the operation and calibration of the emissions analysers, if fitted
- for the Exhaust Gas Cleaning System (**EGCS-SCRUBBER**), the associated systems and monitoring equipment, the following is also to be carried out:
 - visual inspection of all washwater, water treatment pumps and reductant dosing pumps, including openings, for examination, as deemed necessary by the Surveyor
 - visual inspection of all bypass, mixing, isolating, shut-down or control valves in the exhaust, water treatment and dosing systems
 - visual examination and test of all mechanical, hydraulic and pneumatic control actuators and their power systems, as deemed necessary by the Surveyor
 - dock trials on control systems, in order to verify correct operation of the automatic functions, monitoring and alarms systems, safety systems, including override of system functions if provided, manual control and automatic changeover of designated machinery associated with the Exhaust Gas Cleaning Systems

- external examination and operating tests of the equipment and systems, as required in Pt F, Ch 9, Sec 2 and Pt F, Ch 9, Sec 3 (for all additional class notations related to pollution prevention systems).

3.3 Ultra-low emission vessel (ULEV)

3.3.1 At each annual and class renewal survey, the following is to be checked:

- proper operation of the NO_x Control Diagnostic (NCD) and Particulate Control Diagnostic (PCD) systems, when fitted
- proper operation of the recording of the status of the engines related to the operations in the ULEV mode
- confirmation that no modification has been carried out without prior approval of the Society on the engines covered by the **ULEV** additional class notation. In case of replacement or modification of an engine, testing as per Pt F, Ch 11, Sec 26 may be required unless otherwise duly justified and documented by the engine's manufacturer.

3.4 Continuous emission monitoring system (CEMS)

3.4.1 At each annual and class renewal survey, the following is to be checked:

- confirmation that the waste discharge and air emission parameters required to be monitored and recorded are transmitted on a regular basis via a satellite communication system to a shipowner facility ashore
- confirmation that such information is made available to the Surveyor upon request.

4 Ship Energy Efficiency Management Plan (SEEMP)

4.1 Intermediate and class renewal surveys

4.1.1 Onboard verification

The onboard survey is to include the following items:

- a) verification that the implementation of the energy measures is properly recorded
- b) verification by sampling technique that the procedures to measure the data are properly implemented and that the measuring devices are properly maintained and/or calibrated
- c) verification that EEOI and other EnPIs defined in the planning phase, if any, are properly calculated from the collected data over the last 6 months of the ship's operations, and recorded
- d) verification that the SEEMP is onboard and that the record books are kept up to date.

SECTION 8

REFRIGERATING INSTALLATIONS

1 General

1.1

1.1.1 The requirements of this Section apply to ships which have been assigned one of the following additional class notations related to refrigerating installations, as described in Ch 1, Sec 2, [6.9]:

REF-CARGO

REF-CONT

REF-STORE

as well as the following specific notations:

-PRECOOLING

-QUICKFREEZE

-AIRCONT

2 Annual survey

2.1 General

2.1.1 The annual survey of refrigerating installations (plants and spaces) is to be carried out with the installation in running condition and, whenever possible, during unloading operations or without cargo in refrigerated spaces.

2.1.2 The refrigeration installation log-book (or other similar record) is to be made available to the Surveyor for examination of the records since the last survey, and checking any unusual consumption of refrigerant, breakdown or defective items.

2.1.3 Decks, bulkheads or ship sides adjacent to refrigerated spaces are to be checked as far as practicable in order to verify the absence of cold spots.

2.1.4 The Owner or his representative is to declare to the attending Surveyor that no significant modifications have been made to the installations that could affect the class notations without the prior approval by the Society.

2.2 Refrigerating plant

2.2.1 Refrigerating machines and related accessories, including compressors, condensers, pumps and piping are to be examined externally and in running condition. Insulation of insulated parts is to be checked for possible signs of humidity or wear. The tightness of the system is to be ascertained.

2.2.2 The electrical installation is to be generally examined, and the insulation resistance of the installation is to be checked as deemed necessary by the Surveyor.

2.2.3 If independent from the electrical installation of the ship, the generators supplying electrical power to the refrigerating installation are to be examined to the same extent as described in Ch 3, Sec 1, [3.3].

2.3 Refrigerated spaces

2.3.1 Refrigerated spaces are to be generally examined to ascertain the condition of:

- insulation lining; removable panels or covers may be dismantled for examination of insulation, as deemed necessary by the Surveyor
- hatch covers, doors, access panels (including gaskets and securing devices) and dampers of ventilation ducts
- air coils, coolers, fans, air ducts, brine piping systems and associated equipment; cleanliness of grids
- bilge wells
- protection of fans and other rotating machinery, battens for air circulation within the space.

2.4 Instrumentation and safety devices

2.4.1 Thermometers used for measurement of temperature in refrigerated spaces, air ducts and other elements of the installation are to be examined and checked for their accuracy. The Surveyor may require the calibration of one or more thermometers and one or more automation devices to be checked in his presence or, failing this, a certificate of calibration is to be presented to him.

2.4.2 The following alarm and safety devices are also to be checked, as required or fitted:

- alarm and emergency shutdown devices
- CO₂ detectors, if any
- refrigerant leakage detectors
- access to spaces, with regard to possibilities of escape and prevention of personnel being trapped within spaces.

2.5 Notation -AIRCONT

2.5.1 The requirements of this item apply to installations assigned the notation **-AIRCONT**. They are additional to the requirements given in [2.1] to [2.4].

2.5.2 The installation is to be visually examined and tested to verify that the controlled atmosphere system remains satisfactory. The survey is to include the following items:

- examination of voyage logs, records of controlled atmosphere zone air-tightness and calibration of instruments
- confirmation that an operating and safety manual is available on board, complete and duly endorsed by the officers responsible
- examination of controlled atmosphere zone sealing arrangements including cleats and hinges, pressure/vacuum valves, door locks, ventilation of adjacent spaces, warning notices
- test to design pressure of controlled atmosphere zones for air-tightness. Tests by ship's staff within one month prior to the survey may be accepted, based on a written report by the Master subject to visual inspection confirming the air-tightness.
- operation and performance test of the gas supply equipment, including controls, alarms, interlocks and safety devices
- examination and test of ventilation arrangements including fans as deemed necessary
- examination of electrical supply arrangements
- check of gas analysers, analysing equipment and calibration
- check of relative humidity sensors and calibration
- check of permanent and portable gas monitoring, including calibration, and of personnel safety equipment.

3 Class renewal survey

3.1 General

3.1.1 The installation is to be surveyed out of operation in order to enable examinations in opened condition of certain items.

3.1.2 After completion of these examinations, the installation is to be checked while cooling down from the ambient temperature to the lowest design temperature for the refrigerated spaces. The plant is to be examined for ability to maintain stable air temperatures and defrosting operation is to be checked.

3.2 Refrigerating plant

3.2.1 The equipment is to be dismantled to a sufficient extent to enable the following examinations:

- reciprocating compressors: examination of cylinders, valves, crankshaft, connecting rods, pistons, bearings and safety devices
- screw compressors, turbo compressors and pumps: parts subject to wear and tear; the equipment may not need to be opened up if log-book records and a running test show proper functioning.

3.2.2 Prime movers of pumps, compressors and fans are to be examined to the same extent as required in Ch 3, Sec 3, [3] for similar equipment for the class renewal survey of machinery.

3.2.3 Condensers and coolers are to be opened up for examination of tube plates, tubes and end covers.

Condensers are to be pressure tested to 1,2 times the rated working pressure.

3.2.4 Insulation of insulated parts (such as piping and pressure vessels) may need to be removed at random, to ascertain the condition of such parts and of the insulation itself.

3.2.5 The electrical installation of the plant is to be examined and insulation tests checked.

3.2.6 If independent from the electrical installation of the ship, the generators supplying electrical power to the refrigerating installation are to be examined to the same extent as described in Ch 3, Sec 3, [3.6].

3.2.7 Sea connections to condenser circulating pumps are to be opened up and piping examined.

3.2.8 Other equipment, such as oil separators on refrigerant systems, filters and dehydrators, are to be examined to the satisfaction of the Surveyor.

3.3 Refrigerated spaces

3.3.1 The lining and insulation in the refrigerated spaces may need to be partly removed for examination of its condition. The condition of the hull part under the insulation is then ascertained, as well as that of girders, meat rails, hooks and coil/cooler supports.

3.3.2 Air coolers and coils are to be examined and pressure tested at the rated working pressure and at 1,2 times such pressure in the case of hydraulic test after repairs.

3.3.3 Air cooler fans are to be examined and their prime movers are to be checked to the same extent as stated in [3.2.2].

3.3.4 The electrical installation in the refrigerated spaces is to be examined and insulation tests checked.

3.3.5 Defrosting and heating systems are to be examined to the satisfaction of the Surveyor.

3.4 Instrumentation and safety devices

3.4.1 Pressure relief valves and safety disks are to be checked. Discharge piping is to be examined with regard to integrity and non-obstructed flow.

3.5 Notation -AIRCONT

3.5.1 The requirements of this item apply to installations assigned the notation **-AIRCONT**. They are additional to the requirements given in [3.1] to [3.4].

3.5.2 Air compressors, pressure vessels and other equipment are to be examined to the same extent as required in Ch 3, Sec 3, [3] for similar equipment for the class renewal survey of machinery.

3.5.3 Each controlled atmosphere zone is to be subjected to an air-tightness test.

SECTION 9

ARRANGEMENTS FOR NAVIGATION IN ICE

1 General

1.1

1.1.1 The requirements of this Section apply to ships which have been assigned one of the following additional class notations related to navigation in an ice environment, as described in Ch 1, Sec 2, [6.10]:

ICE CLASS IA SUPER

ICE CLASS IA

ICE CLASS IB

ICE CLASS IC

ICE CLASS ID

YOUNG ICE 1

YOUNG ICE 2

ICE

2 Class renewal survey

2.1 Thickness measurements

2.1.1 Additional systematic thickness measurements are required in the areas where strengthening for navigation in an ice environment has been applied in accordance with the requirements in Part F, Chapter 8, as per Tab 1.

2.2 Sea chests

2.2.1 During the bottom survey in dry condition which is to be carried out concurrently with the class renewal survey (see Ch 3, Sec 3, [2.1]), the specific arrangements related to sea chests protected against ice blocking, such as heating coil and cooling water discharge piping, are to be checked.

Table 1 :

Age of ship (in years at time of class renewal survey)		
age ≤ 5	5 < age ≤ 10	age > 10
	selected plates	all plates
		selected internal frames, stiffeners and stringers

SECTION 10

OTHER NOTATIONS

1 General

1.1

1.1.1 The requirements of this Section apply to ships which have been assigned one of the following additional class notations described in Ch 1, Sec 2, [6.14]:

STRENGTHBOTTOM

GRABLOADING and GRAB [X]

SPM

DYNAPOS

VCS

COVENT

CARGOCONTROL

COLD DI

COLD (H t_{DH}, E t_{DE})

COLD CARGO

HABITABILITY, COMF-NOISE-SIS, COMF-NOISE-Pax-SIS, COMF-NOISE-Crew-SIS, COMF-VIB-SIS, COMF-VIB-Pax-SIS, COMF-VIB-Crew-SIS, COMF+-SIS

ACCESS

OHS

HEL

BATTERY SYSTEM

OAS

CBRN, CBRN-WASHDOWN

ELECTRIC HYBRID

CYBER MANAGED, CYBER SECURE

HEADING CONTROL

ECFP-1, ECFP-2, ECFP-3

BIORISK MANAGED, BIORISK SECURED

HYBRID MECHANICAL PROPULSION

AFP-M, AFP-AMC

2 STRENGTHBOTTOM

2.1 Dry-docking survey

2.1.1 The reinforced area of bottom plating and internal associated structures are to be visually examined for possible deformations, fractures or other damage. If deemed necessary, thickness measurements may be required.

3 GRABLOADING and GRAB[X]

3.1 Class renewal survey

3.1.1 The reinforced area of inner bottom plating, lower part of hopper tank sloping plating and transverse lower stool plating and adjacent associated structures, as applicable, are to be visually examined for possible deformations, fractures or other damage. If deemed necessary, thickness measurements may be required.

4 SPM

4.1 Annual survey

4.1.1 The Owner or his representative is to declare to the attending Surveyor that no significant alterations have been made without the prior approval of the Society.

4.1.2 The annual survey is to include:

- a general examination of all components of the installation (bow chain stoppers, bow fairleads, pedestal roller fairleads, winches and capstans) to verify their satisfactory condition
- an examination of the hull structures supporting and adjacent to the installation to verify that no deformations or fractures have developed.

4.2 Class renewal survey

4.2.1 The class renewal survey is to include:

- a close-up examination of all components of the installation (bow chain stoppers, bow fairleads, pedestal roller fairleads, winches and capstans) to verify their satisfactory condition
- a close-up examination of the hull structures supporting and adjacent to the installation to verify that no deformations or fractures have developed.

Where deemed necessary by the Surveyor, non-destructive tests for measuring thickness deterioration or checking for fractures or other defects may be required.

5 DYNAPOS

5.1 Annual survey

5.1.1 The Owner or its representative is to provide a testing program taking into account the FMEA proving trials to the satisfaction of the attending Surveyor.

The Owner or his representative is to declare to the attending Surveyor that no significant alterations have been made without the prior approval of the Society.

5.1.2 The annual survey is to include:

- an examination of the log-books to verify the proper operation of systems in the period subsequent to the last survey and measures taken to avoid repetition of any malfunctions or failures which have occurred during the same period
- a general examination of visible parts of thrust units, including their prime movers
- a general examination of the electrical power system and switchboards
- a general examination of control, monitoring and alarm devices
- a running test of the installation, including random test by simulation of different alarms and relevant backup systems and switching modes
- confirmation that the DP system has been maintained in accordance with applicable parts of the Rules and is found in good working condition
- for ships granted with the additional class notation **DYNAPOS AM/AT-R** or **DYNAPOS AM/AT-RS**, test of all important systems and components to document the ability of the DP vessel to keep position after single failures associated with the assigned equipment class and to validate the FMEA and operations manual. As a minimum, there should be tests of the failures of position and environmental reference systems, thrusters, power generation and distribution systems, position controls and UPS's. Such tests are to be carried out at sea with the DP system in running condition. The results of these tests are to be recorded and kept on board.

Note 1: For ships granted with the - **DDPS** notation, reference is made to Ch 1, Sec 2, [6.14.6] and Pt F, Ch 11, Sec 6, [11] : tests to be carried out at sea may be performed by ship's crew without attendance of a Surveyor and will be reviewed digitally by a Surveyor.

- verification that DP system tests carried out and results are recorded and kept on board.

5.1.3 Every time a defect is discovered and corrected or an accident occurs which affects the safety of the DP vessel, or whenever significant repairs or alterations are made, a survey is to be carried out.

After such survey, tests are to be carried out to demonstrate full compliance with the applicable provisions of the Rules, as necessary.

The type of tests carried out and results are to be recorded and kept on board.

5.2 Class renewal survey

5.2.1 In general, the class renewal survey consists of the checks detailed in [5.2.3] to [5.2.6]. However, a specific program of the class renewal survey prepared by the Owner and taking into account the maintenance procedures of the Manufacturers of the system is to be submitted to the Society prior to the survey.

5.2.2 The Owner is to confirm that any modification to the software is fully documented and properly recorded.

5.2.3 Prime movers of thrust units, electrical installations and electric power generators are to be surveyed and tested to the same extent as required in Ch 3, Sec 3, [3] for similar equipment for the class renewal survey of machinery.

5.2.4 During the bottom survey in dry condition which is to be carried out concurrently with the class renewal survey (see Ch 3, Sec 3, [2.1]), the thrust units are to be generally examined. Other checks are to be carried out, such as taking clearances, examination of the orientation device or variable pitch system, if any, verifying tightness devices, examination of results of lube oil analysis for detection of possible deterioration of internal gears and bearings. Dismantling of internal parts may be required if the above examinations are not satisfactory.

5.2.5 Sensors and position reference systems are to be tested to check their accuracy. Failure of sensors is to be simulated in order to check the related alarm system and switching logic. Switch over to the different reference systems is to be checked.

5.2.6 A complete test of all systems and components and the ability to keep position after single failures associated with the assigned equipment class is to be carried out. The type of tests carried out and results should be recorded and kept on board. The operational tests are to include:

- test of each thrust unit at different loads, pitches and speeds, and check of monitoring devices
- test of the thrust controls in the different available modes (automatic, semi-automatic, manual), and the switch over between the different modes
- test of the different alarms and safety systems, using simulated conditions as necessary
- test of power supply failure and verification of intended functioning in such cases
- final test to verify the capacity of the system to keep the ship in the intended position and maintain the heading, with related alarm and monitoring devices. The accuracy of the system is to be checked and compared with previous results for evaluation of drift
- test of the power management system.

6 VCS

6.1 Annual survey

6.1.1 The Owner or his representative is to declare to the attending Surveyor that no significant modifications have been made without the prior approval of the Society.

6.1.2 The annual survey is to include:

- an examination of the instruction manual to verify the layout of the complete system and confirm the correspondence to the actual system fitted on board
- a general examination of components of the system such as vapour piping (including manifold and hoses), cargo tank gauging equipment, cargo tank level alarms, vapour pressure alarms and vapour balancing, if any, to verify their satisfactory condition.

6.2 Class renewal survey

6.2.1 The requirements given in [6.1] for annual survey are to be complied with. Additionally, the following is to be carried out:

- a pressure test of the vapour piping, including manifold and hoses
- a check and test of the instrumentation (cargo tank gauging equipment, cargo tank level alarms, vapour pressure alarms)
- an inspection and test of the vapour balancing equipment, if any
- a running test of the system.

7 COVENT

7.1 Annual survey

7.1.1 The Owner or his representative is to declare to the attending Surveyor that no significant modifications have been made without the prior approval of the Society.

7.1.2 The annual survey is to include a general examination of components of the system such as ventilation piping and fans.

7.2 Class renewal survey

7.2.1 The requirements given in [7.1] for annual survey are to be complied with. Additionally, the following is to be carried out:

- an inspection of the components of the system to the same extent as required in Ch 3, Sec 3, [3] for similar equipment for the class renewal survey of machinery
- a running test of the system.

8 CARGOCONTROL

8.1 Annual survey

8.1.1 The Owner or his representative is to declare to the attending Surveyor that no significant modifications have been made without the prior approval of the Society.

8.1.2 The annual survey is to include:

- a general examination of the items of equipment regarding remote control of operations and gauging/alarms provided for all those parameters that are required to be kept under control to verify their satisfactory condition
- a running test which may be also performed by a spot check method.

8.2 Class renewal survey

8.2.1 The requirements given in [8.1] for annual survey are to be complied with. Additionally, the following is to be carried out:

- a check and test of the instrumentation fitted to the components of the system
- an overall running test of the system.

9 COLD DI, COLD (H t_{DH}, E t_{DE})

9.1 General

9.1.1 The requirements of this Article apply to ships which have been assigned the following additional class notations defined in Ch 1, Sec 2, [6.14.12]:

COLD DI

COLD (H t_{DH}, E t_{DE})

9.2 Annual survey

9.2.1 The annual survey is to include:

- Availability on-board of the following documentation:
 - when the additional class notation **COLD DI** is assigned:
 - manual for de-icing procedures
 - when the additional class notation **COLD (H t_{DH}, E t_{DE})** is assigned:
 - manual for de-icing procedures
 - stability manual including loading conditions with ice accretion.
- Electrical installations
(for **COLD DI** and **COLD (H t_{DH}, E t_{DE})**):
 - general external examination of the arrangements for heated bridge windows and heated cargo control room windows, the de-icing systems for all escape doors and all main doors giving access to the deck area, the heating of bunker lines on deck, the heating of scupper lines, the heating of whistle, the heating of antennas and similar equipment
 - general external examination of the socket outlets provided close to each lifeboat to supply the heating system of lifeboat engine
 - test of the de-icing systems including indications and alarms, at random
 - test, as far as practicable, of the sequence of ventilation in loop in the air inlet compartment on air intakes for HVAC, machinery room and emergency generator room.
- Machinery installations:
 - general external examination and testing at random of the ventilation system for the machinery compartments (for **COLD DI** and **COLD (H t_{DH}, E t_{DE})**)
 - general external examination of de-icing arrangements for:
 - sea inlets, overboard discharges (above the water line and up to 1 m below the ballast water line), air vent heads (for **COLD (H t_{DH}, E t_{DE})**)
 - air pipes and their automatic closing devices where fitted, sounding pipes and overflow pipes (for cooling water recirculation tanks and water ballast tanks), piping systems in exposed areas including ro-ro spaces, spray water lines, exposed deck scuppers, washing lines and discharge lines (for **COLD DI** and **COLD (H t_{DH}, E t_{DE})**)

- general examination, as far as practicable, of the de-icing arrangements provided to the water ballast tanks adjacent to the shell plating and located totally or partly above the ballast water line (for **COLD (H t_{DH}, E t_{DE})**)
 - general examination, as far as practicable of the de-icing arrangements provided to other tanks subject to freezing (such as fresh water, fuel oil tanks) (for **COLD (H t_{DH}, E t_{DE})**)
 - general examination of the specific heating arrangements provided for the cargo P/V valves (for **COLD DI** and **COLD (H t_{DH}, E t_{DE})**)
 - test of the de-icing systems including indications and alarms, at random (for **COLD DI** and **COLD (H t_{DH}, E t_{DE})**).
- d) Other equipment:
- general external examination of the de-icing system on the exposed deck to allow the de-icing of the ship areas where the crew may have access during the normal operation of the ship (manoeuvring area, loading and unloading area, area around the access to the deckhouses, passageways, gangways, walkways) (for **COLD DI** and **COLD (H t_{DH}, E t_{DE})**)
 - general examination of the specific arrangements for protection of equipment fitted on deck (foam monitors, davits, lifeboats, lifejackets lockers, winches, windlasses, cranes, other deck machinery) and of helideck and its access (for **COLD DI** and **COLD (H t_{DH}, E t_{DE})**)
 - general examination of personal protection and evacuation equipment which are to be suitable for the design temperature (for **COLD (H t_{DH}, E t_{DE})**)
 - general examination of specific protection fitted on cargo valves and associated instrumentation, such as tarpaulins (for **COLD DI** and **COLD (H t_{DH}, E t_{DE})**)
 - general examination of appropriate gratings and stairs (including escapes, access to lifeboats and to winching areas) for facilitation of circulation on exposed decks and of safety lines where provided (for **COLD DI** and **COLD (H t_{DH}, E t_{DE})**)
 - general examination of heating arrangement for hydraulic oil system of deck machinery, where provided (for **COLD DI** and **COLD (H t_{DH}, E t_{DE})**)
 - general examination of arrangements made to ensure 20°C in the accommodation and of arrangements made to control humidity, for HVAC plant (for **COLD DI** and **COLD (H t_{DH}, E t_{DE})**)
 - verification that sufficient hand tools or similar equipment for manual de-icing operations are available on-board and stored on the main deck at locations protected from accumulation of ice (for **COLD DI** and **COLD (H t_{DH}, E t_{DE})**)
 - general examination of navigation and communication equipment which are to be suitable for the design temperature (for **COLD (H t_{DH}, E t_{DE})**).

9.3 Class renewal survey

9.3.1 The requirements given in [9.2] for annual survey are to be complied with. In addition, a test of the de-icing systems, including indications and alarms, is to be carried out.

10 COLD CARGO

10.1 General

The requirements of this Article apply to ships which have been assigned the additional class notation **COLD CARGO**, as defined in Ch 1, Sec 2, [6.14.13].

10.2 Annual survey

10.2.1 The annual survey is to include:

- general examination of the heating system
- general examination of steam/thermal oil pipes insulation for the intended heaters
- general examination of the specific heating arrangements and insulation provided for valves serving the heaters
- general examination and verification of the temperature sensing/monitoring devices and alarms
- general examination of the de-icing arrangements provided for the water ballast tanks adjacent to the cargo tanks
- test of the de-icing systems including indications and alarms, at random
- general examination of the circulating arrangements provided for the liquid cargo in the tanks during heating-up.

10.3 Class renewal survey

10.3.1 The requirements given in [11.2] for annual survey are to be complied with. In addition, a test of all the de-icing systems, including indications and alarms, is to be carried out.

11 HABITABILITY, COMF-NOISE-SIS, COMF-VIB-SIS, COMF+-SIS, COMF-NOISE-Pax-SIS, COMF-NOISE-Crew-SIS, COMF-VIB-Pax-SIS, COMF-VIB-Crew-SIS

11.1 General

11.1.1 The Owner is to inform the Society in order to submit the ship to a survey so as to maintain the additional class notations after modifications, alterations or repairs which could affect the noise and vibration environment have occurred.

11.2 Annual survey

11.2.1 The Owner or his representative is to declare to the attending Surveyor that no significant modifications have been made without the prior approval of the Society, in particular with respect to:

- modifications/repairs carried out in crew or passenger accommodations
- HVAC/duct routing modifications
- machinery modifications, main repairs
- list of any alterations, repairs or damages.

11.3 Class renewal survey

11.3.1 The general wear of the ship can induce vibration and noise increase. In case of additional class notation A survey, including noise and vibration measurements in harbour and sea conditions as well as insulation and impact noise measurements, is to be carried out.

Measurements can be limited in comparison to initial survey measuring points depending on ship's type:

- for cargo ships, 30% of initial survey measuring points
- for passenger ships, 30% of initial survey measuring points (excluding passenger cabins) and 10% of initial survey measuring points in passenger cabins.

In case of additional class notation **HABITABILITY**, noise measurements in harbour and sea conditions, insulation and impact noise measurements are to be carried out only in case of significant modifications, as stated in [11.2.1].

12 Permanent means of access (ACCESS)

12.1 Annual survey, intermediate survey and class renewal survey

12.1.1 General conditions

Visual examination of following parts of permanent means of access is to be carried out in conjunction with surveys of spaces where the notation **ACCESS** is assigned:

- visual examination for signs of corrosion
- examination for satisfactory condition of the marking (e.g. strip, arrows, non-slip surfaces)
- examination of the location lighting where the permanent mean of access is fitted
- examination for satisfactory condition of rails, stanchions, hand rails and other guard rails.

13 Offshore handling systems (OHS)

13.1 Application

13.1.1 The requirements of this Article apply to ships which have been assigned the additional class notation **OHS**, as defined in Ch 1, Sec 2, [6.14.33].

13.2 Periodical surveys

13.2.1 For survey requirements and for periodical surveys, refer to Section 4 of NR595 Classification of Offshore Handling Systems.

14 Helideck (HEL)

14.1 Application

14.1.1 The requirements of this Article apply to ships which have been assigned the additional class notation **HEL**, as defined in Ch 1, Sec 2, [6.14.22].

14.2 Annual surveys

14.2.1 The Society considers that as a minimum these following issues are to be examined during the periodic surveys to confirm that there has been no alteration or deterioration in the condition of the helicopter landing area:

- a) The general examination of the physical characteristics of the helideck is to include:
 - the dimensions as measured
 - the declared D-value
 - the deck shape, and
 - the scale drawings of deck arrangement.
- b) The general examination of the preservation of obstacle-protected surfaces is to include:
 - the minimum 210° Obstacle Free Sector (OFS) surface
 - the 150° Limited Obstacle Sector (LOS) surface, and
 - the minimum 180° falling 5:1 gradient surface with respect to significant obstacles.

Note 1: If one or more of these surfaces is/are infringed due, for example, to the proximity of an adjacent installation or vessel, an assessment is to be made to determine any possible negative effect which may lead to operating restrictions.

- c) The general examination of the marking and lighting is to include:
 - the adequate helideck perimeter lighting
 - the adequate helideck touchdown marking lighting ("H" and TD/PM Circle lighting) and/or floodlighting
 - the status lights (for day and night operations)
 - the helideck markings
 - the dominant obstacle paint schemes and lighting, and
 - the general installation lighting levels including floodlighting.

Note 2: Where inadequate helideck lighting exists, the Helideck Limitation List (HLL) is to be annotated "daylight only operations".

- d) The general examination of the deck surface is to include:
 - the surface friction
 - the helideck net (as applicable)
 - the drainage system
 - the deck edge perimeter safety netting
 - the tie-down points, and
 - the cleaning of all contaminants (to maintain satisfactory recognition of helideck markings and preservation of the helideck friction surface).

- e) The verification of the environment effects is to include:
- foreign object damage
 - air quality degradation due to exhaust emissions, hot and cold vented gas emissions and physical turbulence generators
 - bird control
 - any adjacent helideck/installation having significant environmental effects in any air quality assessment, and
 - flares.
- f) The general examination of the rescue and fire fighting facilities is to include:
- the primary and complementary media types, quantities, capacity and systems
 - the Personal Protective Equipment (PPE), and
 - the crash box.
- g) The general examination of the communications and navigation system arrangements is to include:
- the aeronautical radio(s)
 - the radio/telephone (R/T) call sign to match helideck name and side identification which should be simple and unique
 - the Non-Directional Beacon (NDB) or equivalent (as appropriate), and
 - the radio log.
- h) The general examination of the fuelling facilities is to include:
- the fuel system, ventilation, fire protection and detection
 - the pump and aircraft bonding safety systems.
- i) The general examination of the additional operational and handling equipment is to include:
- the windsock
 - the meteorological information (recorded by an automated means)
 - the Helideck Motion System recording and reporting (where applicable)
 - the passenger briefing system
 - the chocks
 - the tie-downs, and
 - the weighing scales for passengers, baggage and freight.

15 BATTERY SYSTEM

15.1 General

15.1.1 The requirements of this Article apply to ships which have been assigned the additional class notation **BATTERY SYSTEM** as defined in Ch 1, Sec 2, [6.14.36].

15.2 Annual survey

15.2.1 The annual survey is to include:

- general examination of the battery pack(s)
- general examination of the battery monitoring system
- general examination of the battery support system
- general examination of the battery compartment, including visual check of the safety measures and functions related to battery spaces, i.e. battery installation, ventilation, fire safety measures and alarms
- check of the electrolyte level and pH level
- check of State of health (SOH) of battery system according to the Manufacturer's specification and verification that the battery capacity has been regularly recorded and complies with the parameters specified by the Manufacturer
- test of sensor and alarm associated to the battery at random
- undertaking of measurement of insulation of battery packs
- additional checks when some specific part of battery is or has been replaced (e.g. battery cells, BMS) according to the Manufacturer specification and to the satisfaction of the Surveyor.

15.3 Class renewal survey

15.3.1 The requirements given in [15.2.1] for annual survey are to be complied with.

In addition:

- a comprehensive test of indication and alarms is to be carried out
- the traceability of cells replacement is to be checked
- the traceability of software modification is to be checked
- a battery capacity (State of Health - SOH) test is to be witnessed when:
 - release of flammable or toxic gases during battery operation was identified (e.g. hydrogen for lead-acid batteries)
 - loss of battery might jeopardize manoeuvrability of the ship.

16 Offshore Access System (OAS)

16.1 Application

16.1.1 The requirements of this Article apply to ships which have been assigned the additional class notation OAS, as defined in Ch 1, Sec 2, [6.14.38].

16.2 Periodical surveys

16.2.1 For survey requirements and for periodical surveys, refer to Section 9 of NI 629, Certification of Offshore Access Systems.

17 Chemical, biological, radiological or nuclear hazards

17.1 General

17.1.1 The requirements of this Article apply to ships which have been assigned one of the following additional class notation related to CBRN protection as described in Ch 1, Sec 2, [6.14.39]:

- **CBRN**
- **CBRN-WASHDOWN**

17.1.2 At each survey, the Owner or his representative is to declare to the attending surveyor that no significant modifications have been made to the installations that could affect the class notations without prior approval by the Society.

17.2 Annual survey

17.2.1 The CBRN operation manual is to be made available to the Surveyor and may be used as a basis for survey.

An examination of the log-books is to be carried out to verify the proper operation of the systems in the period subsequent to the last survey and measures taken to avoid repetition of any malfunctions and failures which have occurred during the same period.

17.2.2 The annual survey is to include:

- Examination and testing, as feasible, of airlocks, cleansing station(s) and CBRN protection plant(s)
- Examination of CBRN detection system, check number and location of each detector
- Verification that each opening in the citadel and shelter boundaries is provided with a closing appliance in working order and suitably marked
- Verification of remote indication, alarm and control functions at the CBRN control station
- Verification of ventilation non-return devices
- Verification of water traps or equivalent devices against air entrance
- Examination of CBRN ventilation system, including ducts, filters and dampers
- For ships assigned with the additional class notation **CBRN-WASHDOWN**: Examination of pre-wetting and wash down system, including piping, valves and nozzles.

17.3 Class renewal survey

17.3.1 The CBRN operation manual is to be made available to the Surveyor and may be used as a basis for survey.

An examination of the log-books is to be carried out to verify the proper operation of the systems in the period subsequent to the last survey and measures taken to avoid repetition of any malfunctions and failures which have occurred during the same period.

17.3.2 The class renewal survey is to include:

- Verification of gas tightness of citadel, shelter, air lock and cleansing station boundaries. For this purpose, the tested spaces are to be pressurized with all openings closed, and the air supply is to be isolated. It is then to be checked that the pressure can be maintained for 10 min in the tested space.
- Check of overpressure levels in the citadel with the collective protection ventilation system working. The required overpressure is to be held for at least 30 min. The test may be carried out with dummy filters in lieu of CBRN filters. This test may be carried out with the ventilation system fed by the main power source. Proper functioning of the ventilation system when fed by the emergency power source is also to be checked.
- Check of gastightness of engine enclosure and associated supply and exhaust ducts, for engines with dedicated air supply
- Check of air conditioning capability under CBRN condition.
- Functioning test of the CBRN detection system. Each line is to be tested from the level of the detector, with means defined by the system supplier.
- For ships assigned with the additional class notation **CBRN-WASHDOWN**, functioning test of the pre-wetting and wash down system, including verification that all external surfaces are properly covered, verification of water drainage and verification of section valve remote operation.

18 ELECTRIC HYBRID

18.1 General

18.1.1 The requirements of this Article apply to ships which have been assigned the additional class notation **ELECTRIC HYBRID** as defined in Ch 1, Sec 2, [6.14.40].

18.2 Annual survey

18.2.1 The survey is to include:

- verification of proper working of monitoring systems
- verification of proper working of alarms and defaults and related functions and/or interfacing to the other ship systems
- disconnection of the ESS in different operating modes, and automatic start of stand by source, as necessary
- test of the fire detection of the battery compartment
- test of the gas detection system of the battery compartment
- examination of the fire-extinguishing system of the battery compartment as applicable in accordance with the relevant requirements given in Ch 3, Sec 1, [3.4]
- verification that accessibility for common maintenance and devices for battery overhaul, if any, are maintained.

18.2.2 In addition to the requirements [18.2.1], for **PM** mode, the survey is to include:

- increasing load steps, as far as practicable. The ESS is to deliver power to the grid, to compensate for the load steps. In case of continuous load, the load is to be gradually transferred to the running diesel engine. The load is to be shared equally between the diesel engines (see Pt C, Ch 2, Sec 4, [2.2.5])
- additional increasing load steps, with load dependant start of a stand-by main generating set activated, as far as practicable.

18.2.3 In addition to the requirements of [18.2.1], for **PB** mode, the survey is to include:

- failure of one generator and automatic connection of the ESS
- failure of one generator and ESS autonomy measurement (starting of the stand by generator is blocked)
- automatic start of a stand by source in case of failure of the ESS or low state of charge of the ESS.

18.2.4 In addition to the requirements of [18.2.1], for **ZE** mode, the survey is to include:

automatic start of a stand by source in case of failure of the ESS or low state of charge of the ESS.

18.3 Class renewal survey

18.3.1 In addition to the requirements given in [18.2.1] for annual survey the following requirements are to be complied with:

- verification of the quality of the power supply in the different modes
- examination of the fire-extinguishing system as applicable in accordance with the relevant requirements given in Ch 3, Sec 3, [3.8].

18.3.2 In addition to the requirements of [18.3.1], for **PM** mode, the survey is to include:

confirmation of the capacity of the batteries by verification of the proper operation of the ESS during 6 hours at least in normal working condition; however, where proper record is maintained, consideration may be given to accepting recent records effected by the ship's personnel. The ESS state of charge is not to be less than 80% at the end of the 6 hours period. A load analysis curve corresponding to this period is to be submitted for information. This document is to detail the total electrical production on board, the main generating sets electrical production and the ESS electrical production (with charging and discharging cycles).

18.3.3 In addition to the requirements of [18.3.1], for **ZE** mode, the survey is to include:

load discharge test with ESS autonomy measurement up to ESS state of charge low level.

18.3.4 In addition to the requirements of [18.3.1], for **PB** and **ZE** modes, the survey is to include:

ESS charging test, with evaluation of charging current and time for complete charging of the batteries (to reach full charge, just after a full discharge, in the conditions defined by the load balance).

19 CYBER MANAGED and CYBER SECURE

19.1 General

19.1.1 The requirements of this Article apply to ships which have been assigned one of the following additional class notations related to cyber security as described in Ch 1, Sec 2, [6.14.44]:

- **CYBER MANAGED**
- **CYBER SECURE**

The surveys are to be systematically recorded in the cyber registry: date, actors, tests performed, results and conclusions.

19.2 Annual surveys

19.2.1 Documents

Confirmation from Cyber Security Responsible, that any modification carried out on the approved documents as listed in NR659 has been declared to the Society.

19.2.2 Surveys

The tests contained in NR659 are conducted in principle under the responsibility of the Cyber Security Responsible.

The test evidences are to be reviewed by the Surveyor.

19.3 Intermediate surveys

19.3.1 Documents to be updated

Regarding Level 3 equipment only, the following documents are to be updated:

- Cyber Risk Analysis
- Cyber Repository (system identification part).

19.3.2 Documents to be submitted

The following documents are to be submitted:

- Cyber Registry
- Cyber Handbook, if modified
- Cyber Survey Manual, if modified.

19.3.3 Surveys

The Surveyor verifies that test reports submitted by the Cyber Security Responsible are consistent with the approved Cyber Survey Manual.

19.4 Class renewal surveys

19.4.1 Documents to be updated

The following documents are to be updated:

- Cyber Risk Analysis.

Regarding Level 2 and Level 3 equipment only, the following documents are to be updated:

- Cyber Repository (system identification part).

19.4.2 Documents to be submitted

The following documents are to be submitted:

- Cyber Registry
- Cyber Handbook, if modified
- Cyber Survey Manual, if modified.

19.4.3 Surveys

The Surveyor verifies that test reports submitted by the Cyber Security Responsible are consistent with the approved Cyber Survey Manual.

20 Heading control

20.1 General

20.1.1 The requirements of this Article apply to ships which have been assigned one of the following additional class notations **HEADING CONTROL-DS** or **HEADING CONTROL-IS** as described in Ch 1, Sec 2, [6.14.46].

20.2 Annual survey

20.2.1 At each annual survey the Owner or his representative is to declare to the attending Surveyor that no modifications have been made to the systems affecting the notations without prior approval by the Society.

20.3 Class renewal survey

20.3.1 At each class renewal survey a test is to be conducted in order to ascertain that the systems affecting the notations operate satisfactorily. This test is usually to be carried out during sea trials, as described in Pt F, Ch 11, Sec 28, [5.2].

21 Enhanced cargo fire protection on container ships

21.1 General

21.1.1

The requirements of this Article apply to ships which have been assigned one of the following additional class notations defined in Ch 1, Sec 2, [6.14.48]:

ECFP-1

ECFP-2

ECFP-3

21.2 Annual survey

21.2.1 The annual survey is to include:

- a) Checking of fire-fighter's outfits, breathing apparatuses and portable thermal imaging camera and confirmation that they are stored in the appropriate locations
- b) Confirmation that the required supply of compressed air for breathing apparatuses is provided and examination of the arrangements for the air compressor(s) and air piping system

21.2.2 In addition to the requirements of [21.2.1], for ships granted with **ECFP-2** or **ECFP-3** notation, the survey is to include:

- a) Water monitors covering the cargo stowage area on deck:
 - general examination of all parts of the water monitor system (pumps, piping system, valves and other fittings)
 - checking for proper operation of the system, including local manual control
 - general examination of foundations of water monitors.
- b) Examination of the water-spray system below hatch cover in accordance with the relevant requirements given in Ch 3, Sec 1, [3.4.2] item d).
- c) Flooding system for the cargo holds:
 - examination of the system, including piping, nozzles and distribution valves
 - confirmation that cargo hold sea water level sensors are operational and that high and high high level alarms are satisfactory
 - examination of the drainage arrangements
- d) General examination of all parts, as far as practicable and visible, of the water-spray system for the protection of the accommodation block, and of scuppers and freeing ports for water drainage from deck surfaces
- e) Checking that the means of remotely closing the accommodation block ventilation inlets and the remote controls for the cargo hold power ventilation are in working order.

21.3 Class renewal survey

21.3.1 In addition to the requirements of [21.2.1], the class renewal survey is to include:

- a) Examination and test of prime movers of the air compressor for refilling of air bottles of breathing apparatuses.

21.3.2 In addition to the requirements of [21.3.1] and [21.2.2], the class renewal survey for ships granted with **ECFP-2** or **ECFP-3** is to include:

- a) Operational testing and internal examination, as required by the Surveyor, of the relevant pumps for the following systems:
 - water monitors covering the cargo stowage area on deck
 - water-spray system below hatch cover
 - flooding system for the cargo holds
 - water-spray system for the protection of the accommodation block
- b) Testing of the means of remotely closing the accommodation block ventilation inlets and remote control for the cargo hold power ventilation.

22 Biological risk control

22.1 General

22.1.1 The requirements of this Article apply to ships which have been assigned the additional class notation **BIORISK MANAGED** or **BIORISK SECURED**, as defined in Ch 1, Sec 2, [6.14.50].

At each survey, the Owner or his representative is to declare to the attending surveyor that no changes or updates of the Outbreak Management Plan have been made since the last version that was submitted to the Society.

22.2 BIORISK MANAGED

22.2.1 Annual and class renewal survey

The annual and class renewal surveys are to include:

- verification that the Outbreak Management Plan is available on board
- verification that there is a register of PPEs and medical supplies required by the Outbreak Management Plan on board
- verification that the posters, signs and markings required by the Outbreak Management Plan are available on board
- verification that the operational records required by the Outbreak Management plan are available.

22.3 BIORISK SECURED

22.3.1 Annual survey

In addition to the requirements for **BIORISK MANAGED** given in [22.2.1], the annual survey is to include:

- verification that a means of monitoring body temperature is available on board
- verification that one totally enclosed stretcher and one totally enclosed wheelchair are available on board
- verification that a means of communication for the quarantine area is available onboard.

22.3.2 Class renewal survey

In addition to the requirements for annual survey given in [22.3.1], the class renewal survey is to include:

- functional testing of the ventilation arrangements for the quarantine area and for the accommodation spaces and normally manned control stations. It is to be checked that the ventilation system is functioning properly with the air filtration or alternative air disinfection system working
- functional testing of the means of monitoring the access to the quarantine area
- functional testing of the means of monitoring body temperature.

23 Hybrid mechanical propulsion

23.1 General

23.1.1 The requirements of this Article apply to ships which have been assigned the additional class notation **HYBRID MECHANICAL PROPULSION**, as defined in Ch 1, Sec 2, [6.14.49].

23.2 Annual survey

23.2.1 The annual survey is to include:

- confirmation of proper working of alarms and defaults and related functions and/or interfacing to the other ship systems
- test of manual switch from diesel propulsion mode to electric propulsion mode (PTI Fully electric mode and PTI Booster mode, if available)
- test of manual switch from electric propulsion mode to diesel propulsion Mode
- test of transfer of control between the different control positions.

23.3 Class renewal survey

23.3.1 In addition to the requirements of [23.2.1], the class renewal survey is to include:

- test of automatic switch from electric propulsion mode to diesel propulsion.

24 Enhanced fire protection

24.1 General

24.1.1 The requirements of this Article apply to ships which have been assigned the additional class notation **EFP-M** or **EFP-AMC**, as defined in Ch 1, Sec 2, [6.14.18].

24.2 Annual survey

24.2.1 The annual survey is to include a verification that the insulation applied in way of following items is found in satisfactory condition:

- surfaces of engines, boilers, steam, thermal oil and exhaust gas lines, silencers, exhaust gas boilers and turbochargers or other equipment where hot surfaces above 220 °C may be expected, with the engines or concerned equipment under normal operating conditions are properly insulated
- surfaces, having temperature exceeding 60°C, with which the crew are likely to come into contact during operation are to be suitably protected or insulated.

In case of doubt the surveyor may require a thermal imaging scanning to be performed in accordance with the requirements of Pt F, Ch 11, Sec 15 [5].

Part A
Classification and Surveys

Chapter 6

**RETROACTIVE REQUIREMENTS FOR
EXISTING SHIPS**

- SECTION 1 GENERAL**
- SECTION 2 BULK CARRIERS, ORE CARRIERS AND
COMBINATION CARRIERS**
- SECTION 3 RO-RO PASSENGER SHIPS**
- SECTION 4 CARGO SHIPS**
- SECTION 5 SHIPS WITH ICE CLASSES**
- APPENDIX 1 TECHNICAL RETROACTIVE REQUIREMENTS FOR BULK
CARRIERS AND OTHER TYPES OF SHIPS**

SECTION 1 GENERAL

1 General

1.1

1.1.1 The purpose of this Chapter is to deal with the retroactive rule requirements applicable to existing ships which derive from the implementation of SOLAS regulations, IACS Unified Requirements or specific regulations from an Administration.

1.1.2 These requirements are relevant to both construction features and surveyable items. They are laid down in the following Sections according to the service notations assigned to ships.

This Chapter also contains an Appendix for ready reference reproducing the text of the retroactive IACS Unified Requirements relevant to ships assigned the service notation **bulk carrier ESP**.

As a rule, requirements related to additional service features **BC-A**, **BC-B** or **BC-C** are not applicable to ships having the service notation **bulk carrier ESP** contracted for construction before 1st July 2003 or contracted for construction on or after 1st July 2003 but less than 150 m in length.

1.2 List of retroactive rule requirements

1.2.1 Tab 1 summarises these retroactive requirements indicating the service notations to which they are applicable and in which Section they are given.

Table 1 : Summary of retroactive rule requirements

Service notation	Section in Chapter 6	Ship's survey items or features concerned
bulk carrier ESP	Ch 6, Sec 2	<ul style="list-style-type: none"> - Scantlings of transverse bulkhead between the two foremost cargo holds - Allowable hold loading of the foremost cargo hold - Damage stability - Intermediate survey in lieu of annual survey in the foremost cargo hold - Detection of water ingress into cargo holds - Cargo hatch cover securing arrangements - Renewal criteria for side shell frames and brackets - Restriction from sailing with any hold empty
bulk carrier ESP ore carrier ESP combination carrier/OBO ESP combination carrier/OOC ESP	Ch 6, Sec 2	<ul style="list-style-type: none"> - Loading conditions, loading manuals and loading instruments - Strength and securing of small hatches on the exposed fore deck - Strength requirements for fore deck fittings and equipment - Hold, ballast and dry space water level detectors - Availability of pumping systems
ro-ro passenger ship	Ch 6, Sec 3	<ul style="list-style-type: none"> - Increased stability and watertight integrity
general cargo ship bulk carrier (without ESP) refrigerated cargo ship livestock carrier deck ship	Ch 6, Sec 4	<ul style="list-style-type: none"> - Strength and securing of small hatches on the exposed fore deck - Strength requirements for fore deck fittings and equipment
ships with Ice Classes	Ch 6, Sec 5	<ul style="list-style-type: none"> - Maintenance of additional class notations ICE CLASS IA SUPER, ICE CLASS IA, ICE CLASS IB, ICE CLASS IC

SECTION 2

BULK CARRIERS, ORE CARRIERS AND COMBINATION CARRIERS

1 Foremost cargo hold requirements

1.1 Application

1.1.1 These retroactive rule requirements apply to ships with service notation **bulk carrier ESP**:

- of single side skin construction see Note 1
- of 150 metres in length and above
- intended to carry solid bulk cargoes having a bulk density of 1,78 t/m³ or above
- contracted for construction prior to 1st July 1998, and not constructed in compliance with the applicable requirements for new buildings contracted after that date, and given in Pt D, Ch 4, Sec 3.

Note 1: Single side skin bulk carriers means, as defined in SOLAS conf. 4/25 Res.6, where one or more cargo holds are bound by the side shell only or by two watertight boundaries, one of which is the side shell, which are less than 760 mm apart in bulk carriers constructed before 1st January 2000, and less than 1000 mm apart in bulk carriers constructed on or after 1st January 2000. The distance between the watertight boundaries is to be measured perpendicular to the side shell (ref.: IMO MSC Res.89(71)).

1.1.2 They are related to:

- scantlings of the transverse corrugated cargo hold bulkhead between the two foremost cargo holds, as detailed in [1.3]
- allowable hold loading of the foremost cargo hold with the same hold flooded, as detailed in [1.4]
- damage stability with the foremost cargo hold flooded, as detailed in [1.5].

1.2 Schedule for compliance

1.2.1 These requirements are to be complied with by the following limit dates:

- for ships which were 20 years of age or more on 1st July 1998, by the due date of the first intermediate survey or the due date of the first class renewal survey, to be held after 1st July 1998, whichever comes first
- for ships which were 15 years of age or more, but less than 20 years on 1st July 1998, by the due date of the first class renewal survey to be held after 1st July 1998, but not later than 1st July 2002

- for ships which were 10 years of age or more, but less than 15 years on 1st July 1998, by the due date of the next intermediate survey or class renewal survey after the date on which the ship reaches 15 years of age, but not later than the date on which the ship reaches 17 years of age
- for ships which were 5 years of age or more, but less than 10 years on 1st July 1998, by the due date, after 1st July 2003, of the next intermediate survey or class renewal survey after the date on which the ship reaches 10 years of age, whichever occurs first
- for ships which were less than 5 years of age on 1st July 1998, by the date on which the ship reaches 10 years of age.

1.2.2 Completion, prior to 1st July 2003, of an intermediate or class renewal survey with a due date after 1st July 2003, cannot be used to postpone compliance.

However, completion prior to 1st July 2003 of an intermediate survey the window for which straddles 1st July 2003 can be accepted.

1.3 Scantlings of the vertically corrugated transverse watertight bulkhead between the two foremost cargo holds

1.3.1 The net scantlings of the vertically corrugated transverse watertight bulkhead between the two foremost cargo holds are to be assessed in accordance with the method given in Ch 6, App 1, [2].

In these requirements, homogeneous loading condition means a loading condition in which the ratio between the highest and the lowest filling ratio, evaluated for the two foremost cargo holds, does not exceed 1,20, to be corrected for different cargo densities.

1.3.2 Thickness measurements are necessary to determine the general condition of the structure and to define the extent of possible repairs and/or reinforcements of the vertically corrugated transverse watertight bulkhead for verification of the compliance with the requirements given in Ch 6, App 1, [2].

Thickness measurements and assessment of the scantlings are to be carried out for the initial evaluation at the limit date as defined in [1.2.1], and thereafter at each subsequent intermediate survey (for ships over 10 years of age) and each subsequent class renewal survey for purposes of verifying continuing compliance with the above mentioned requirements.

1.3.3 Taking into account the buckling criteria applied in Ch 6, App 1, [2] in the evaluation of strength of the bulkhead, it is essential to determine the thickness diminution at the critical levels shown in Fig 1 and Fig 2.

1.3.4 Thickness measurements are to be carried out at the levels indicated in [1.3.5]. To adequately assess the scantlings of each individual vertical corrugation, each corrugation flange, web, shedder plate (see Ch 6, App 1, Fig 4 and Ch 6, App 1, Fig 5) and gusset plate (see Ch 6, App 1, Fig 6, Ch 6, App 1, Fig 7 and Ch 6, App 1, Fig 8) within each of the levels indicated in [1.3.5] is to be measured.

1.3.5 The locations at which thickness measurements are to be carried out are as follows for each of the prescribed levels a, b and c:

- level a - bulkheads without lower stool (see Fig 1)
 - the mid-breadth of the corrugation flanges and webs at approximately 200 mm above the line of shedder plates
 - the middle of gusset plates between corrugation flanges, where fitted
 - the middle of the shedder plates
- level b - bulkheads with lower stool (see Fig 2)
 - the mid-breadth of the corrugation flanges and webs at approximately 200 mm above the line of shedder plates
 - the middle of gusset plates between corrugation flanges, where fitted
 - the middle of the shedder plates
- level c - bulkheads with or without lower stool (see Fig 1 and Fig 2)
 - the mid-breadth of the corrugation flanges and webs at approximately the mid-height of the corrugation.

Where the thickness changes within the horizontal levels, the thinner plate is to be measured.

1.3.6 Where necessary, steel renewal and/or reinforcements are to meet the requirements given in Ch 6, App 1, [2.6].

1.4 Allowable hold loading of the foremost cargo hold with the same hold flooded

1.4.1 The loading in the foremost cargo hold is not to exceed the allowable hold loading in the flooded condition. The method of calculation is laid down in Ch 6, App 1, [4].

In no case is the allowable hold loading in the flooding condition to be taken greater than the design hold loading in the intact condition.

1.5 Damage stability

1.5.1 Bulk carriers which are subject to compliance with the requirements laid down in [1.3.1] and [1.4.1] are, when loaded to the summer loadline, to be able to withstand flooding of the foremost cargo hold in all loading conditions and remain afloat in a satisfactory condition of equilibrium, as specified in [1.5.2].

1.5.2 The condition of equilibrium after flooding is to satisfy the condition of equilibrium laid down in Pt B, Ch 3, App 4. The assumed flooding need only take into account flooding of the cargo hold. The permeability of a loaded hold is to be assumed as 0,90 and the permeability of an empty hold is to be assumed as 0,95, unless a permeability relevant to a particular cargo is assumed for the volume of a flooded hold occupied by cargo and a permeability of 0,95 is assumed for the remaining empty volume of the hold.

1.5.3 Bulk carriers which have been assigned a reduced freeboard in compliance with the provisions of Pt B, Ch 3, App 4 may be considered as complying with [1.5.1].

Figure 1 : Thickness measurement areas of cargo hold transverse bulkhead without lower stool

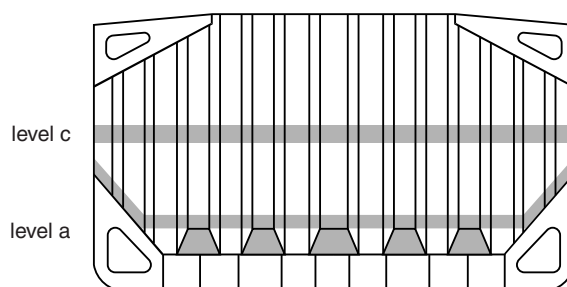
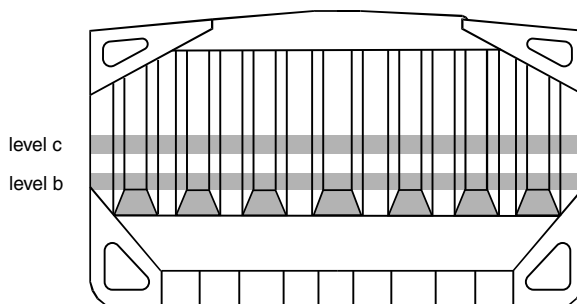


Figure 2 : Thickness measurement areas of cargo hold transverse bulkhead with lower stool



2 Loading instruments and loading manuals

2.1 Loading instruments

2.1.1 Bulk carriers, ore carriers and combination carriers, which are assigned one of the following service notations:

- **bulk carrier ESP**
- **ore carrier ESP**
- **combination carrier/OBO ESP**
- **combination carrier/OOC ESP**

of 150 m length and above, which were contracted for construction before 1st July 1998, are to be provided with an approved loading instrument of a type to the satisfaction of the Society not later than their entry into service or 1st January 1999, whichever occurs later.

2.2 Loading manuals

2.2.1 All single side skin bulk carriers which are assigned the service notation **bulk carrier ESP**, of 150 m length and above, which were contracted for construction before 1st July 1998 are to be provided before 1st July 1999, or their entry into service whichever occurs later, with an approved loading manual with typical loading sequences where the ship is loaded from commencement of cargo loading to reaching full deadweight capacity, for homogeneous conditions, relevant part load conditions and alternate conditions, where applicable. Typical unloading sequences for these conditions are also to be included.

Guidance for preparation of such loading/unloading sequences is given in Ch 6, App 1, [7].

3 Strength requirements for fore deck fittings and equipment, strength and securing of small hatches on the exposed fore deck

3.1 Application and requirements

3.1.1 These retroactive rule requirements apply to ships which are assigned one of the following service notations:

- **bulk carrier ESP**
- **bulk carrier BC-A ESP**
- **bulk carrier BC-B ESP**
- **bulk carrier BC-C ESP**
- **ore carrier ESP**
- **combination carrier/OBO ESP**
- **combination carrier/OOC ESP,**

of 100 m in length and above, that are contracted for construction prior to 1st January 2004.

3.1.2 These retroactive rule requirements provide strength requirements to resist green sea forces for the following items located within the forward quarter length: air pipes, ventilator pipes and their closing devices.

They are applicable only for air pipes, ventilator pipes and their closing devices on the exposed deck serving spaces forward of the collision bulkhead, and to spaces which extend over this line aft-wards.

The provisions for compliance with these strength requirements for fore deck fittings and equipment are given in Pt C, Ch 1, Sec 10, [9.1.9].

These retroactive rule requirements are also applicable for small hatches on the exposed deck giving access to spaces forward of the collision bulkhead, and to spaces which extend over this line aft-wards.

They are related to the strength of, and securing for, such small hatches fitted on the exposed fore deck.

The provisions for compliance with these requirements for strength and securing of small hatches on the exposed fore deck are given in Pt B, Ch 8, Sec 8, [3].

Note 1: For ships contracted for construction prior to 1st July 2007, the following is to be carried out:

- securing devices of hatches designed for emergency escape are to be of a quick-acting type (e.g. one action wheel handles are to be provided as central locking devices for latching/unlatching of hatch cover) operable from both sides of the hatch cover,

by the compliance date specified in [3.2.1] or by the due date of the first class renewal survey after 1st July 2007 whichever is later. Completion prior to 1st July 2007 of a class renewal survey with a due date after 1st July 2007 cannot be used to postpone compliance.

Note 2: These requirements do not apply to the cargo tank venting systems and the inert gas systems of tankers.

3.2 Schedule for compliance

3.2.1 Ships referred to in [3.1.1] are to comply with the provisions of Pt B, Ch 8, Sec 8, [3] and of Pt C, Ch 1, Sec 10, [9.1.9] by the following dates:

- for ships which will be 15 years of age or more on 1st January 2004, by the due date of the first intermediate or class renewal survey after that date
- for ships which will be 10 years of age or more on 1st January 2004, by the due date of the first class renewal survey after that date
- for ships which will be less than 10 years of age on 1st January 2004, by the date on which the ship reaches 10 years of age.

3.2.2 Completion, prior to 1st January 2004, of an intermediate or class renewal survey with a due date after 1st January 2004 cannot be used to postpone compliance. However, completion prior to 1st January 2004 of an intermediate survey the window for which straddles 1st January 2004 can be accepted.

4 Cargo hatch cover securing arrangements for bulk carriers

4.1 Application and requirements

4.1.1 These retroactive rule requirements apply to ships which are assigned one of the following service notations:

- **bulk carrier ESP**
- **bulk carrier BC-A ESP**
- **bulk carrier BC-B ESP**
- **bulk carrier BC-C ESP,**

and which were not built in accordance with Pt B, Ch 9, Sec 7, [1] to Pt B, Ch 9, Sec 7, [7] of edition February 2003 of the Rules as amended in accordance with November 2003 amendments or subsequent editions.

4.1.2 They are related to steel hatch cover securing devices and stoppers for cargo hold hatchways No 1 and No 2 which are wholly or partially within 0,25 L of the fore perpendicular, except pontoon type hatch cover.

The provisions for compliance with these requirements for cargo hatch cover securing arrangements are given in Ch 6, App 1, [6].

4.2 Schedule for compliance

4.2.1 Ships referred to in [4.1.1] are to comply with the provisions of Ch 6, App 1, [6] by the following dates:

- for ships which will be 15 years of age or more on 1st January 2004, by the due date of the first intermediate or class renewal survey after that date
- for ships which will be 10 years of age or more on 1st January 2004, by the due date of the first class renewal survey after that date
- for ships which will be less than 10 years of age on 1st January 2004, by the date on which the ship reaches 10 years of age.

4.2.2 Completion, prior to 1st January 2004 of an intermediate or class renewal survey with a due date after 1st January 2004 cannot be used to postpone compliance. However, completion prior to 1st January 2004 of an intermediate survey the window for which straddles 1st January 2004 can be accepted.

5 Renewal criteria for side shell frames and brackets in single side skin bulk carriers and single side skin OBO carriers

5.1 Application and requirements

5.1.1 These retroactive rule requirements apply to:

- the side shell frames and brackets of cargo holds bounded by the single side shell of ships with service notation **bulk carrier ESP** constructed with single deck, topside tanks and hopper tanks in cargo spaces intended primarily to carry dry cargo in bulk,
- the side shell frames and brackets of cargo holds bounded by the single side shell of ships with service notation **combination carrier/OBO ESP** as defined in Ch 1, Sec 2, [4.3.4] but of single side skin construction,

which were not built in accordance with the applicable requirements of Part II, Chapter 8, Section 8-03 of the 1st April 1998 edition of the Rules or subsequent editions.

In the case a ship as defined above does not satisfy above definition in one or more holds, the retroactive rule requirements do not apply to these individual holds.

5.1.2 These requirements define steel renewal criteria or other measures (reinforcement or coating) to be taken for the webs and flanges of side shell frames and brackets as per the provisions of Ch 6, App 1, [5].

Reinforcing measures of side frames are also defined as per Ch 6, App 1, [5.4.2].

Finite element or other numerical analysis or direct calculation procedures cannot be used as an alternative to compliance with these requirements, except in cases of unusual side structure arrangements or framing to which these requirements cannot be directly applied. In such cases, the analysis criteria and the strength check criteria are to be in accordance with the Rules of the Society.

5.2 Schedule for compliance

5.2.1 Steel renewal, reinforcement or coating, where required in accordance with Ch 6, App 1, [5], is to be carried out in accordance with the following schedule and at subsequent intermediate and class renewal surveys, for ships with service notation **bulk carrier ESP**.

- for ships which will be 15 years of age or more on 1st January 2004, by the due date of the first intermediate or class renewal survey after that date
- for ships which will be 10 years of age or more on 1st January 2004, by the due date of the first class renewal survey after that date
- for ships which will be less than 10 years of age on 1st January 2004, by the date on which the ship reaches 10 years of age.

5.2.2 For ships with service notation **bulk carrier ESP**, completion, prior to 1st January 2004, of an intermediate or class renewal survey with a due date after 1st January 2004 cannot be used to postpone compliance. However, completion prior to 1st January 2004 of an intermediate survey the window for which straddles 1st January 2004 can be accepted.

5.2.3 Steel renewal, reinforcement or coating, where required in accordance with Ch 6, App 1, [5], is to be carried out in accordance with the following schedule and at subsequent intermediate and class renewal surveys, for ships with service notation **combination carrier/OBO ESP**:

- for ships which will be 15 years of age or more on 1st July 2005, by the due date of the first intermediate or class renewal survey after that date
- for ships which will be 10 years of age or more on 1st July 2005, by the due date of the first class renewal survey after that date
- for ships which will be less than 10 years of age on 1st July 2005, by the date on which the ship reaches 10 years of age.

5.2.4 For ships with service notation **combination carrier/OBO ESP**, completion, prior to 1st July 2005 of an intermediate or class renewal survey with a due date after 1st July 2005 cannot be used to postpone compliance. However, completion prior to 1st July 2005 of an intermediate survey the window for which straddles 1st July 2005 can be accepted.

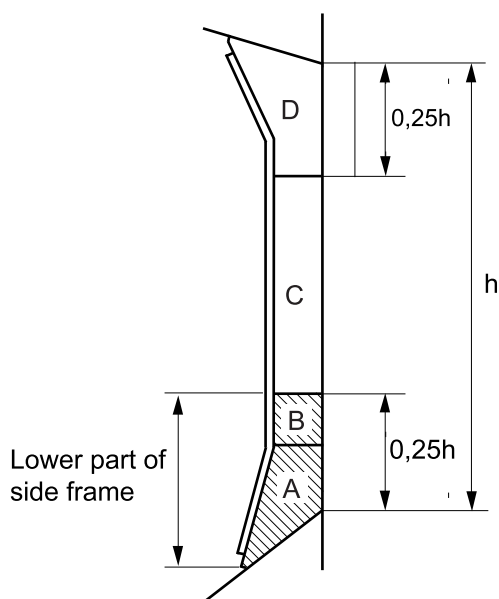
5.3 Requirements for the gauging of side shell frames and brackets

5.3.1 Gauging is required to determine the general condition of the structure and to define the extent of possible steel renewals or other measures for the webs and flanges of side shell frames and brackets for verification of the compliance with the requirements of Ch 6, App 1, [5].

5.3.2 For the purpose of steel renewal, sand blasting and coating, four zones A, B, C and D are defined, as shown in Fig 3.

Zones A and B are considered to be the most critical zones.

Figure 3 : Zones of side shell frames and brackets



5.3.3 Pits can grow in a variety of shapes, some of which would need to be ground before assessment.

Pitting corrosion may be found under coating blisters, which must be removed before inspection.

To measure the remaining thickness of pits or grooving, a miniature transducer (3 to 5 mm diameter) must be used. Alternatively, the gauging firm must use a pit gauge to measure the depth of the pits and grooving and calculate the remaining thickness.

The assessment based upon area is the method specified in Ch 6, App 1, [5.4.4] and is based upon the intensity determined from Fig 4.

If pitting intensity is higher than 15% in an area (see Fig 4), then thickness measurements are to be taken to check the extent of the pitting corrosion. The 15% is based upon pitting or grooving on only one side of the plate.

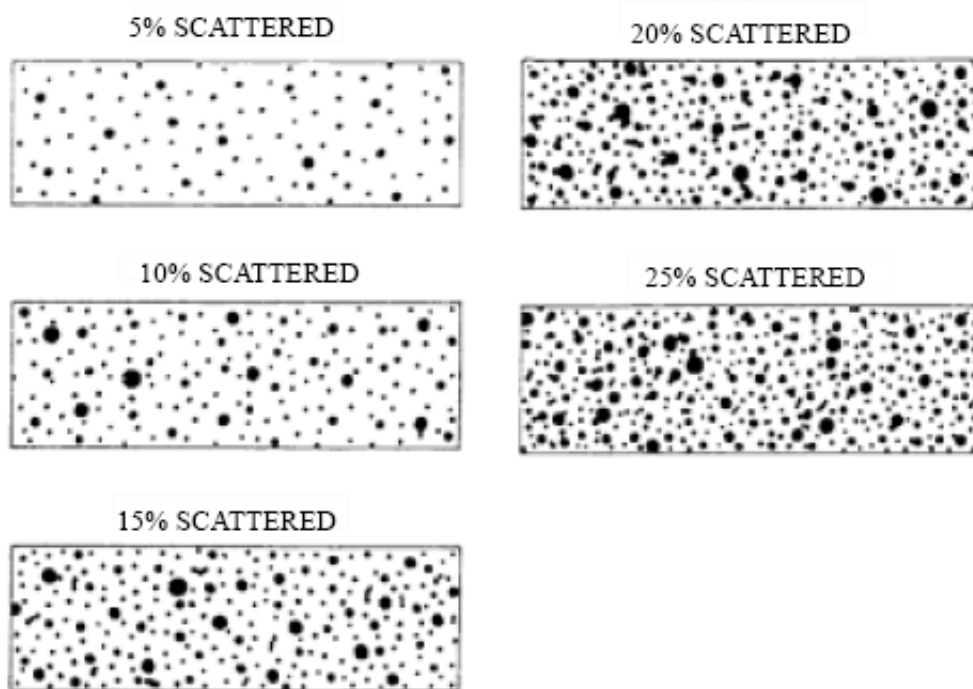
In cases where pitting is evident as defined above (exceeding 15%), then an area of 300 mm diameter or more (or, where this is impracticable on the frame flange or the side shell, hopper tank plating or topside tank plating attached to the side frame, an equivalent rectangular area), at the most pitted part, is to be cleaned to bare metal, and the thickness measured in way of the five deepest pits within the cleaned area. The least thickness measured in way of any of these pits is to be taken as the thickness to be recorded.

The minimum acceptable remaining thickness in any pit or groove is equal to:

- 75% of the as-built thickness, for pitting or grooving in the cargo hold side frame webs and flanges
- 70% of the as-built thickness, for pitting or grooving in the side shell, hopper tank and topside tank plating attached to the cargo hold side frame, over a width up to 30 mm from each side of it.

5.3.4 Numbers of side frames to be measured are equivalent to those of the class renewal survey or intermediate survey corresponding to the ship's age. Representative thickness measurements are to be taken for each zone as specified below.

Figure 4 : Pitting intensity diagrams (from 5% to 25% intensity)



Special consideration to the extent of the thickness measurements may be given by the Society, if the structural members show no thickness diminution with respect to the as-built thicknesses and the coating is found in "as-new" condition (i.e without breakdown or rusting).

Where gauging readings close to the criteria are found, the number of hold frames to be measured is to be increased.

If renewal or other measures according to the present Article [5] are to be applied on individual frames in a hold, then all frames in that hold are to be gauged.

There is a variety of construction methods used for side shell frames in bulk carriers. Some have face plates (T sections) on the side shell frames, some have flanged plates and some have bulb plates. The use of face plates and flanged sections is considered similar for gauging purposes in that both the web and face plate or web and flange plate are to be gauged. If bulb plate has been used, then web of the bulb plate is to be gauged in the normal manner and the sectional modulus has to be specially considered if required.

5.3.5 The gauging pattern for web plating for zones A, B and D are to be a five point pattern (see Fig 5). The 5 point pattern is to be over the depth of the web and the same area vertically. The gauging report is to reflect the average reading.

5.3.6 Depending upon the condition of the web in way of zone C, the web plating for zone C is to be measured by taking 3 readings over the length of zone C and averaging them. The average reading is to be compared with the

allowable thickness. If the web plating has general corrosion then this pattern is to be expanded to a five point pattern as noted in [5.3.5].

5.3.7 Where the lower bracket length or depth does not meet the requirements in Pt D, Ch 4, Sec 3, [2.2.6], gaugings are to be taken at sections a) and b) to calculate the actual section modulus required in Ch 6, App 1, [5.5.5] (see Fig 6). At least 2 readings on the flange/face plate are to be taken in way of each section. At least one reading of the attached shell plating is to be taken on each side of the frame (i.e. fore and aft) in way of section a) and section b).

Figure 5 : Typical 5 point pattern on the web plate

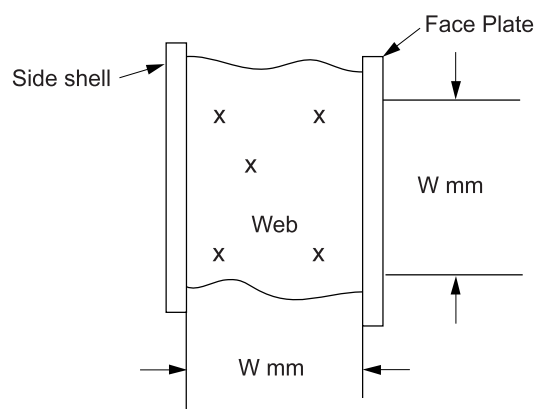
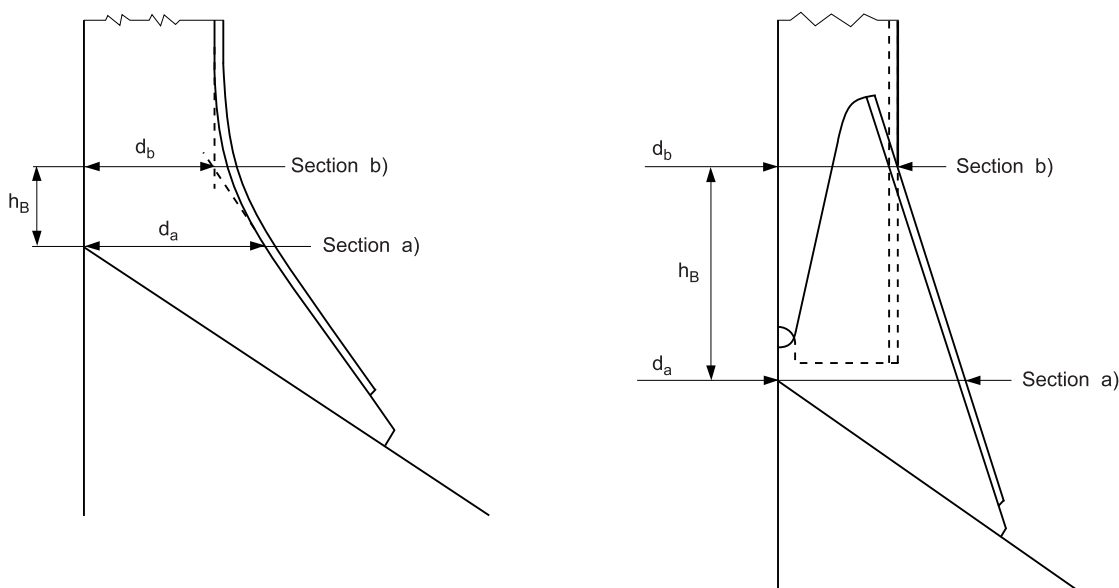


Figure 6 : Sections a) and b)



- d_a : Lower bracket web depth for determining $t_{REN, S}$
- d_b : Frame web depth
- h_B : Lower bracket length.

6 Hold, ballast and dry space water level detectors

6.1 Application and requirements

6.1.1 These retroactive rule requirements apply to ships which are assigned one of the following service notations:

- **bulk carrier ESP**
- **bulk carrier BC-A ESP**
- **bulk carrier BC-B ESP**
- **bulk carrier BC-C ESP**
- **ore carrier ESP**
- **combination carrier/OBO ESP**
- **combination carrier/OOC ESP,**

of 500 GT and above constructed before 1 July 2004.

6.1.2 They are related to the fitting of water level detectors. The provisions for compliance with these requirements are given in Pt C, Ch 1, Sec 10, [6.12.1] and Pt C, Ch 1, Sec 10, [6.6.3], item d).

6.2 Schedule for compliance

6.2.1 Ships referred to in [6.1.1] are to comply with the provisions of Pt C, Ch 1, Sec 10, [6.12.1] and Pt C, Ch 1, Sec 10, [6.6.3], item d) not later than the date of the annual, intermediate or class renewal survey of the ship to be carried out after 1st July 2004, whichever comes first.

7 Availability of pumping systems

7.1 Application and requirements

7.1.1 These retroactive rule requirements apply to ships which are assigned one of the following service notations:

- **bulk carrier ESP**
- **bulk carrier BC-A ESP**
- **bulk carrier BC-B ESP**
- **bulk carrier BC-C ESP**
- **ore carrier ESP**
- **combination carrier/OBO ESP**
- **combination carrier/OOC ESP,**

of 500 GT and above constructed before 1st July 2004.

7.1.2 They are related to the availability of pumping systems.

The provisions for compliance with these requirements are given in Pt C, Ch 1, Sec 10, [6.6.3], item e).

7.2 Schedule for compliance

7.2.1 Ships referred to in [7.1.1] are to comply with the provisions of Pt C, Ch 1, Sec 10, [6.6.3], item e) not later than the date of the first intermediate or class renewal survey of the ship to be carried out after 1st July 2004, but in no case later than 1st July 2007.

8 Restriction from sailing with any hold empty

8.1 Application and requirements

8.1.1 These retroactive rule requirements apply to ships which are assigned one of the service notations **bulk carrier ESP** or **combination carrier/OBO ESP**:

- of single side skin construction
- of 150 metres in length and above
- intended to carry solid bulk cargoes having a density of 1,78 t/m³ in alternate hold loading conditions
- contracted for construction prior to 1st July 1998 or constructed before 1st July 1999.

8.1.2 Such ships, if not meeting the requirements for withstanding flooding of any one cargo hold, as specified in Part II, Chapter 8, Section 8-03, 8-032-2, 8-037-3 and 8-033-4 of the 1st April 1998 edition of the Rules or subsequent editions, and the retroactive requirements for side structure of bulk carriers of single-side skin construction, as specified in [5], are not to sail with any hold loaded to less than 10% of the hold's maximum allowable cargo weight when in the full load condition, after reaching 10 years of age.

The applicable full load condition for this requirement is a load equal to, or greater than, 90% of the ship's deadweight at the relevant assigned freeboard.

8.1.3 Any restrictions imposed on the carriage of solid bulk cargoes having a density of 1,78 t/m³ and above in accordance with these requirements are to be identified and recorded in the loading manual.

8.1.4 A ship to which the requirements in [8.1.3] apply is to be permanently marked on the side shell amidships, port and starboard, with a solid equilateral triangle having sides of 500 mm and its apex 300 mm below the deck line, and painted a contrasting colour to that of the hull.

SECTION 3

RO-RO PASSENGER SHIPS

1 General

1.1 Application

1.1.1 Ships which have been assigned the service notation **ro-ro passenger ship** constructed before 1st July 1997 are to comply with all the requirements indicated in [2].

2 Increased stability and watertight integrity

2.1

2.1.1 Ships referred to in [1.1.1] are to comply with the provisions of Pt D, Ch 12, Sec 3, [2.3] not later than the first class renewal survey after the prescribed date of compliance given in Tab 1, according to the value of A/A_{\max} as defined in the annex of the Calculation Procedure to assess the survivability characteristics of existing ro-ro passenger ships when using a simplified method based upon resolution A.265(VIII), developed by the Maritime Safety Committee at its fifty-ninth session in June 1991 (MSC/Circ. 574).

Table 1 : Date of compliance according to A/A_{\max}

Value of A/A_{\max}	Date of compliance
$A/A_{\max} < 85\%$	1 st October 1998
$85\% \leq A/A_{\max} < 90\%$	1 st October 2000
$90\% \leq A/A_{\max} < 95\%$	1 st October 2002
$95\% \leq A/A_{\max} < 97,5\%$	1 st October 2004
$A/A_{\max} \geq 97,5\%$	1 st October 2005

2.1.2 Notwithstanding the provisions of [2.1.1], ships referred to in [1.1.1] which are certified to carry 400 persons or more are to comply with the provisions of Pt D, Ch 12, Sec 3, [2.3.12], assuming the damage applied anywhere within the ship's length L, not later than the date of the first class renewal survey after the prescribed date of compliance, which is the one occurring the latest among those given in Tab 2, Tab 3 and item a).

Table 2 : Date of compliance according to A/A_{\max}

Value of A/A_{\max}	Date of compliance
$A/A_{\max} < 85\%$	1 st October 1998
$85\% \leq A/A_{\max} < 90\%$	1 st October 2000
$90\% \leq A/A_{\max} < 95\%$	1 st October 2002
$95\% \leq A/A_{\max} < 97,5\%$	1 st October 2004
$A/A_{\max} \geq 97,5\%$	1 st October 2010

Table 3 : Date of compliance according to the number of persons permitted to be carried

Number of persons (N.)	Date of compliance
$N. \geq 1500$	1 st October 2002
$1000 \leq N. < 1500$	1 st October 2006
$600 \leq N. < 1000$	1 st October 2008
$400 \leq N. < 600$	1 st October 2010

- a) when the age of the ship is equal to or greater than 20 years, where the age of the ship means the time counted from the date on which the keel was laid, or the date on which it was at a similar stage of construction, or from the date on which the ship was converted to a ro-ro passenger ship.

SECTION 4 CARGO SHIPS

1 Strength requirements for fore deck fittings and equipment, strength and securing of small hatches on the exposed fore deck

1.1 Application and requirements

1.1.1 These retroactive rule requirements apply to ships which are assigned one of the following service notations:

- **general cargo ship**
- **bulk carrier** (without ESP additional service feature)
- **refrigerated cargo ship**
- **livestock carrier**
- **deck ship,**

of 100 m in length and above, that are contracted for construction prior to 1st January 2004.

Note 1: The requirements also apply to dedicated forest product carriers (other than woodchip carriers) and to dedicated cement carriers.

1.1.2 These retroactive rule requirements provide strength requirements to resist green sea forces for the following items located within the forward quarter length: air pipes, ventilator pipes and their closing devices.

They are applicable only for air pipes, ventilator pipes and their closing devices on the exposed deck serving spaces forward of the collision bulkhead, and to spaces which extend over this line aft-wards.

The provisions for compliance with these strength requirements for fore deck fittings and equipment are given in Pt C, Ch 1, Sec 10, [9.1.9].

These retroactive rule requirements are also applicable for small hatches on the exposed deck giving access to spaces forward of the collision bulkhead, and to spaces which extend over this line aft-wards.

They are related to the strength of, and securing for, such small hatches fitted on the exposed fore deck.

The provisions for compliance with these requirements for strength and securing of small hatches on the exposed fore deck are given in Pt B, Ch 8, Sec 8, [3].

Note 1: For ships contracted for construction prior to 1st July 2007, the following is to be carried out:

- securing devices of hatches designed for emergency escape are to be of a quick-acting type (e.g. one action wheel handles are to be provided as central locking devices for latching/unlatching of hatch cover) operable from both sides of the hatch cover, by the compliance date specified in [1.2.1] or by the due date of the first class renewal survey after 1st July 2007 whichever is later. Completion prior to 1st July 2007 of a class renewal survey with a due date after 1st July 2007 cannot be used to postpone compliance.

Note 2: These requirements do not apply to the cargo tank venting systems and the inert gas systems of tankers.

1.2 Schedule for compliance

1.2.1 Ships referred to in [1.1.1] are to comply with the provisions of Pt B, Ch 8, Sec 8, [3] and of Pt C, Ch 1, Sec 10, [9.1.9] by the following dates:

- for ships which will be 15 years of age or more on 1st January 2004, by the due date of the first intermediate or class renewal survey after that date
- for ships which will be 10 years of age or more on 1st January 2004, by the due date of the first class renewal survey after that date
- for ships which will be less than 10 years of age on 1st January 2004, by the date on which the ship reaches 10 years of age.

1.2.2 Completion, prior to 1st January 2004, of an intermediate or class renewal survey with a due date after 1st January 2004 cannot be used to postpone compliance. However, completion prior to 1st January 2004 of an intermediate survey the window for which straddles 1st January 2004 can be accepted.

2 Water level detectors on single hold cargo ships other than bulk carriers

2.1 Application and requirements

2.1.1 These retroactive rule requirements normally apply to ships which are assigned one of the following service notations:

- **general cargo ship** (see Note 1 hereafter)
- **bulk carrier** (without ESP additional service feature)
- **refrigerated cargo ship**
- **container ship,**
- **ro-ro cargo ship** (see Note 2 hereafter)
- **livestock carrier**
- **deck ship** (see Note 2 hereafter)
- **liquefied gas carrier** (of LPG type) (see Note 2 hereafter)
- **supply vessel** (see Note 2 hereafter)

and

- of gross tonnage equal or above 500 ums, and
- constructed before 1st January 2007 with length of less than 80 m, or 100 m if constructed before 1st July 1998, and
- with a single cargo hold below the freeboard deck or cargo holds below the freeboard deck which are not separated by at least one bulkhead made watertight up to that deck.

Note 1: The requirements also apply to dedicated cement carriers, dedicated forest product carriers, dedicated woodchip carriers, timber and log carriers with the same conditions.

Note 2: The scope of application for these type of ships is subject to special consideration.

2.1.2 They are related to the fitting of water level detectors in such space or spaces.

2.1.3 The water level detectors required by the present Article need not be fitted in ships complying with Ch 6, Sec 2,

[6], or in ships having watertight side compartments each side of the cargo hold length extending vertically at least from inner bottom to freeboard deck.

2.2 Schedule for compliance

2.2.1 Ships referred to in [2.1.1] are to comply with the provisions of Ch 6, App 1, [8] not later than 31st December 2009.

SECTION 5

SHIPS WITH ICE CLASSES

1 General

1.1 Application

1.1.1 Ships which have been assigned the additional class notations **ICE CLASS IB** or **ICE CLASS IC**, the keel of which has been laid or which has been at a similar stage of construction on 1st November 1986 or thereafter, but before 1st September 2003, are to comply with the requirements indicated in [2.1.1].

1.1.2 Ships which have been assigned the additional class notations **ICE CLASS IA SUPER** or **ICE CLASS IA**, the keel of which has been laid or which has been at a similar stage of construction before 1st September 2003, are to comply with the requirements indicated in [2.1.2].

1.1.3 Ships which have been assigned one of the additional class notations **ICE CLASS IA SUPER** or **ICE CLASS IA** or **ICE CLASS IB** or **ICE CLASS IC** built before 1st July 2007 are to comply with the requirements indicated in [3].

2 Requirements to maintain ice classes

2.1

2.1.1 Ships referred to in [1.1.1] are to comply with the provisions of Pt F, Ch 8, Sec 1, [3.1] of the June 2000 edition of the Rules, in order to maintain their additional class notations **ICE CLASS IB** or **ICE CLASS IC**.

Note 1: In the formula of the BV Rules June 2000 edition, Pt F, Ch 8, Sec 1, [3.1], the displacement restriction is applied only to the part in the formula which is in parenthesis, and not to form factor F_3 . The full displacement of the ship is to be used in factor F_3 .

2.1.2 Ships referred to in [1.1.2] are to comply with the provisions of Pt F, Ch 8, Sec 1, [3.1.3], in order to maintain their additional class notations **ICE CLASS IA SUPER** or **ICE CLASS IA**, at the following dates:

- 1st January 2005 or
- 1st January in the year when 20 years has elapsed since the year the ship was delivered,

whichever occurs the latest.

When, for an existing ship, values for some of the hull form parameters required for the calculation method in Pt F, Ch 8, Sec 1, [3.1.3] are difficult to obtain, the following alternative formulae can be used:

$$R_{CH} = C_1 + C_2 + C_3 (H_F + H_M)^2 (B + 0,658 H_F) + C_4 L H_F^2 + C_5 \left(\frac{LT}{B^2} \right)^3 \frac{B}{4}$$

$$\text{with } 5 \leq \left(\frac{LT}{B^2} \right)^3 \leq 20$$

- for **ICE CLASS IA**

C_1 and C_2 are to be taken as zero.

- for **ICE CLASS IA SUPER**

Ship without a bulb, C_1 and C_2 are to be calculated as follows:

$$C_1 = f_1 \frac{BL}{2 \frac{T}{B} + 1} + 1,84 (f_2 B + f_3 L + f_4 BL)$$

$$C_2 = 3,52 (g_1 + g_2 B) + g_3 \left(1 + 1,2 \frac{T}{B} \right) \frac{B^2}{\sqrt{L}}$$

- for **ICE CLASS IA SUPER**

Ship with a bulb, C_1 and C_2 are to be calculated as follows:

$$C_1 = f_1 \frac{BL}{2 \frac{T}{B} + 1} + 2,89 (f_2 B + f_3 L + f_4 BL)$$

$$C_2 = 6,67 (g_1 + g_2 B) + g_3 \left(1 + 1,2 \frac{T}{B} \right) \frac{B^2}{\sqrt{L}}$$

Values of f_i and g_i are given in Tab 1.

Table 1 : Values of f_i and g_i

$f_1 = 10,3 \text{ N/m}^2$	$g_1 = 1530 \text{ N}$
$f_2 = 45,8 \text{ N/m}$	$g_2 = 170 \text{ N/m}$
$f_3 = 2,94 \text{ N/m}$	$g_3 = 400 \text{ N/m}^{1,5}$
$f_4 = 5,8 \text{ N/m}^2$	

$$C_3 = 460 \text{ kg/(m}^2 \cdot \text{s}^2)$$

$$C_4 = 18,7 \text{ kg/(m}^2 \cdot \text{s}^2)$$

$$C_5 = 825 \text{ kg/s}^2$$

3 Ice class draught marking

3.1

3.1.1 Ships referred to in [1.1.3] are to be provided with a warning triangle and with an ice class draught mark at the maximum permissible ice class draught amidships as indicated in Pt F, Ch 8, Sec 1, Fig 2, if the UIWL is below the summer load line, not later than the first scheduled bottom survey in dry-dock after the 1st July 2007.

Note 1: The upper ice waterline (UIWL) shall be the envelope of the highest points of the waterlines at which the ship is intended to operate in ice. The line may be a broken line.

APPENDIX 1

TECHNICAL RETROACTIVE REQUIREMENTS FOR BULK CARRIERS AND OTHER TYPES OF SHIPS

1 General

1.1

1.1.1 The present Appendix contains the technical requirements applicable retroactively to existing ships listed in Ch 6, Sec 2.

2 Evaluation of scantlings of the transverse watertight vertically corrugated bulkheads between the two foremost cargo holds

2.1 Application and definitions

2.1.1 These requirements apply to ships indicated in Ch 6, Sec 2, [1.1.1].

2.1.2 In these requirements, homogeneous loading condition means a loading condition in which the ratio between the highest and the lowest filling ratio, evaluated for the two foremost cargo holds, does not exceed 1,20, to be corrected for different cargo densities.

2.1.3 The net scantlings of the transverse bulkhead between the two foremost cargo holds are to be calculated using the loads given in [2.2], the bending moment and shear force given in [2.3] and the strength criteria given in [2.4].

Where necessary, steel renewal and/or reinforcements are required as per [2.6].

2.2 Load model

2.2.1 General

The loads to be considered as acting on the bulkhead are those given by the combination of the cargo loads with those induced by the flooding of the foremost cargo hold.

The most severe combinations of cargo induced loads and flooding loads are to be used for the check of the scantlings of the bulkhead, depending on the loading conditions included in the loading manual:

- homogeneous loading conditions
- non-homogeneous loading conditions.

Non-homogeneous part loading conditions associated with multipoint loading and unloading operations for homogeneous loading conditions need not be considered according to these requirements.

2.2.2 Bulkhead corrugation flooding head

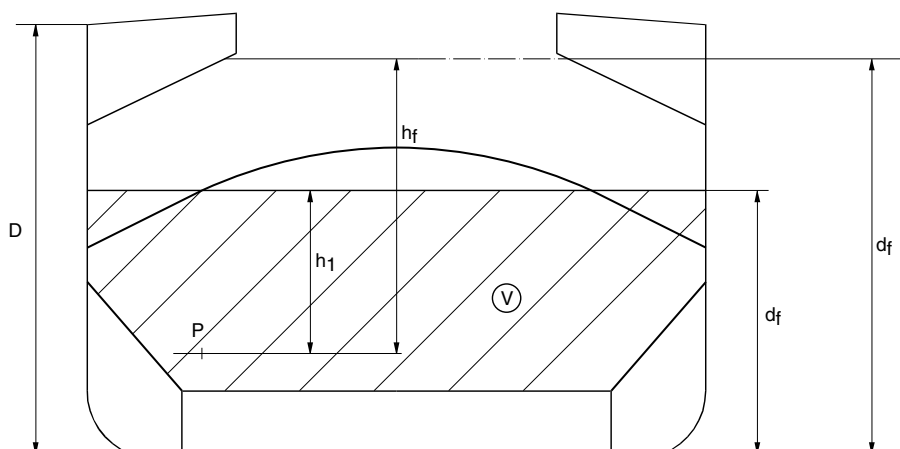
The flooding head h_f (see Fig 1) is the distance, in m, measured vertically with the ship in the upright position, from the calculation point to a level located at a distance d_f , in m, from the base line equal to:

- D in general
- $0,95 D$ for ships less than 50000 t deadweight with type B freeboard,

D being the distance, in m, from the base line to the freeboard deck at side amidships (see Fig 1).

For ships to be operated at an assigned load line draught Tr less than the permissible load line draught T , the flooding head defined for the two cases above may be reduced by $(T - Tr)$.

Figure 1 : Calculation of pressure on the bulkhead in the flooded cargo hold



V = Volume of cargo
P = Calculation point

2.2.3 Pressure in the flooded hold: bulk cargo loaded hold

Two cases are to be considered, depending on the values of d_1 and d_f , d_1 (see Fig 1) being a distance from the base line given, in m, by:

$$d_1 = \frac{M_c}{\rho_c l_c B} + \frac{V_{LS}}{l_c B} + (h_{HT} - h_{DB}) \frac{b_{HT}}{B} + h_{DB}$$

where:

M_c : Mass of cargo, in t, in the foremost cargo hold

ρ_c : Bulk cargo density, in t/m³

l_c : Length of the foremost cargo hold, in m

B : Ship's breadth amidships, in m

V_{LS} : Volume, in m³, of the bottom stool above the inner bottom

h_{HT} : Height of the hopper tanks amidships, in m, from the base line

h_{DB} : Height of the double bottom, in m

b_{HT} : Breadth of the hopper tanks amidships, in m.

a) Case when $d_f \geq d_1$

At each point of the bulkhead located at a distance between d_1 and d_f from the base line, the pressure $p_{c,f}$, in kN/m², is given by:

$$p_{c,f} = \rho g h_f$$

where:

ρ : Sea water density, in t/m³

g : Gravity acceleration, equal to 9,81 m/s²

h_f : Flooding head as defined in [2.2.2].

At each point of the bulkhead located at a distance lower than d_1 from the base line, the pressure $p_{c,f}$, in kN/m², is given by:

$$p_{c,f} = \rho g h_f + [\rho_c - \rho (1 - \text{perm})] g h_1 \tan^2 \gamma$$

where:

ρ, g, h_f : As given above

ρ_c : Bulk cargo density, in t/m³

perm : Permeability of cargo, to be taken as 0,3 for ore (corresponding bulk cargo density for iron ore may generally be taken as 3,0 t/m³)

h_1 : Vertical distance, in m, from the calculation point to a level located at a distance d_1 , as defined above, from the base line (see Fig 1)

γ : $\gamma = 45^\circ - (\phi / 2)$

ϕ : Angle of repose of the cargo, in degrees, and may generally be taken as 35° for iron ore.

The force $F_{c,f}$, in kN, acting on a corrugation is given by:

$$F_{c,f} = s_1 \left[\rho g \frac{(d_f - d_1)^2}{2} + \frac{\rho g (d_f - d_1) + (p_{c,i})_{le}}{2} (d_1 - h_{DB} - h_{LS}) \right]$$

where:

s_1 : Spacing of corrugations, in m (see Fig 2)

ρ, g, d_1, h_{DB} : As given above

d_f : As given in [2.2.2]

$(p_{c,i})_{le}$: Pressure, in kN/m², at the lower end of the corrugation

h_{LS} : Height of the lower stool, in m, from the inner bottom.

b) Case when $d_f < d_1$

At each point of the bulkhead located at a distance between d_f and d_1 from the base line, the pressure $p_{c,f}$, in kN/m², is given by:

$$p_{c,f} = \rho_c g h_1 \tan^2 \gamma$$

where:

ρ_c, g, h_1, γ : As given in a) above

At each point of the bulkhead located at a distance lower than d_f from the base line, the pressure $p_{c,f}$, in kN/m², is given by:

$$p_{c,f} = \rho g h_f + [\rho_c h_1 - \rho (1 - \text{perm}) h_1] g \tan^2 \gamma$$

where:

$\rho, g, h_f, \rho_c, h_1, \text{perm}, \gamma$: As given in item a) above.

The force $F_{c,f}$, in kN, acting on a corrugation is given by:

$$F_{c,f} = s_1 \left[\rho_c g \frac{(d_1 - d_f)^2}{2} \tan^2 \gamma \right] + s_1 \left[\frac{\rho_c g (d_1 - d_f) \tan^2 \gamma + (p_{c,i})_{le}}{2} (d_f - h_{DB} - h_{LS}) \right]$$

where:

$s_1, \rho_c, g, \gamma, (p_{c,i})_{le}, h_{LS}$: As given in a) above

d_1, h_{DB} : As given in [2.2.3]

d_f : As given in [2.2.2].

2.2.4 Pressure in the flooded hold: empty hold

At each point of the bulkhead, the hydrostatic pressure p_f induced by the flooding head h_f is to be considered.

The force F_f , in kN, acting on a corrugation is given by:

$$F_f = s_1 \rho g \frac{(d_f - h_{DB} - h_{LS})^2}{2}$$

where:

s_1, ρ, g, h_{LS} : As given in [2.2.3], item a)

h_{DB} : As given in [2.2.3]

d_f : As given in [2.2.2].

2.2.5 Pressure in the non-flooded bulk cargo loaded hold

At each point of the bulkhead, the pressure p_c , in kN/m^2 , is given by:

$$p_c = \rho_c g h_1 \tan^2 \gamma$$

where:

ρ_c, g, h_1, γ : As given in [2.2.3], item a).

The force F_c , in kN, acting on a corrugation is given by:

$$F_c = s_1 \rho_c g \frac{(d_1 - h_{DB} - h_{LS})^2}{2} \tan^2 \gamma$$

where:

$\rho_c, g, s_1, h_{LS}, \gamma$: As given in [2.2.3], item a)

d_1, h_{DB} : As given in [2.2.3].

2.2.6 Resultant pressure in homogeneous loading conditions

At each point of the bulkhead structures, the resultant pressure p , in kN/m^2 , to be considered for the scantlings of the bulkhead is given by:

$$p = p_{c,f} - 0,8 p_c$$

The resultant force F , in kN, acting on a corrugation is given by:

$$F = F_{c,f} - 0,8 F_c$$

2.2.7 Resultant pressure in non-homogeneous loading conditions

At each point of the bulkhead structures, the resultant pressure p , in kN/m^2 , to be considered for the scantlings of the bulkhead is given by:

$$p = p_{c,f}$$

The resultant force F , in kN, acting on a corrugation is given by:

$$F = F_{c,f}$$

Where the foremost cargo hold, in non-homogeneous loading conditions, is not allowed to be loaded, the resultant pressure p , in kN/m^2 , to be considered for the scantlings of the bulkhead is given by:

$$p = p_f$$

and the resultant force F , in kN, acting on a corrugation is given by:

$$F = F_f$$

2.3 Bending moment and shear force in the bulkhead corrugations

2.3.1 General

The bending moment M and the shear force Q in the bulkhead corrugations are obtained using the formulae given in [2.3.2] and [2.3.3]. The M and Q values are to be used for the checks in [2.4].

2.3.2 Bending moment

The design bending moment M , in kN.m , for the bulkhead corrugations is given by:

$$M = \frac{F\ell}{8}$$

where:

F : Resultant force in kN, as given in [2.2.6] or [2.2.7]

ℓ : Span of the corrugation, in m, to be taken according to Fig 2 and Fig 3.

Figure 2 : Parameters of vertically corrugated bulkhead

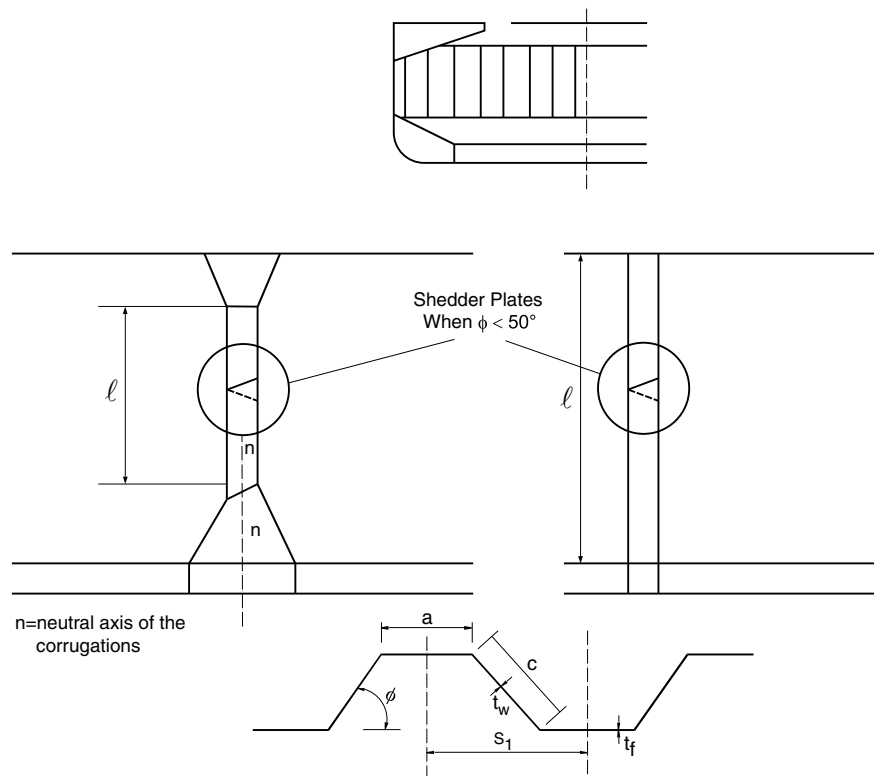
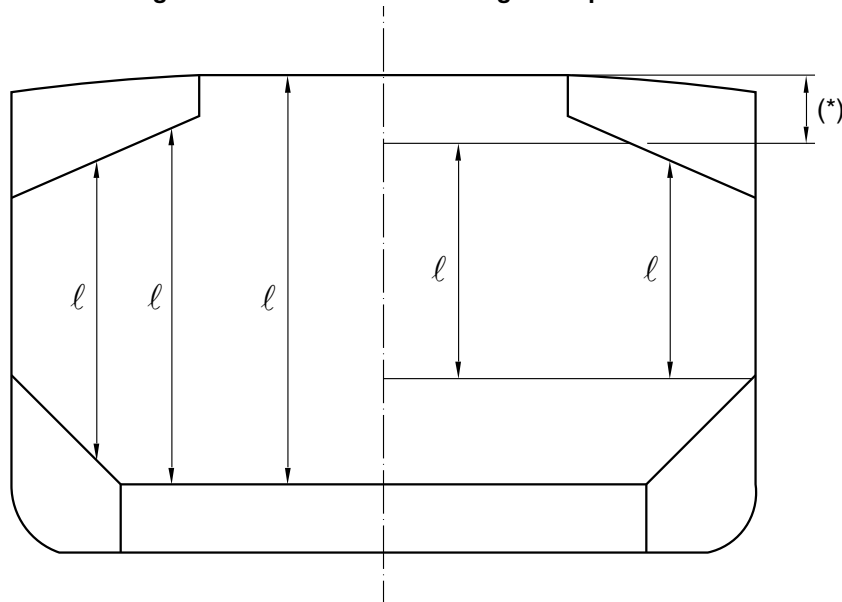


Figure 3 : Definition of the corrugation span



(*): For the definition of l , the internal end of the upper stool is not to be taken more than a distance from the deck at the centreline equal to:

- three times the depth of corrugations, in general
- twice the depth of corrugations, for rectangular stool.

2.3.3 Shear force

The shear force Q , in kN, at the lower end of the bulkhead corrugations is given by:

$$Q = 0,8 F$$

where:

F : As given in [2.2.6] or [2.2.7].

2.4 Strength criteria

2.4.1 General

The following criteria are applicable to transverse bulkheads with vertical corrugations (see Fig 2).

Requirements for local net plate thickness are given in [2.4.8].

In addition, the criteria given in [2.4.2] and [2.4.5] are to be complied with.

Where the corrugation angle ϕ shown in Fig 2 is less than 50° , a horizontal row of staggered shedder plates is to be fitted at approximately mid-depth of the corrugations (see Fig 2) to help preserve dimensional stability of the bulkhead under flooding loads. The shedder plates are to be welded to the corrugations by double continuous welding, but they are not to be welded to the side shell.

The thicknesses of the lower part of corrugations considered in the application of [2.4.2] and [2.4.3] are to be maintained for a distance from the inner bottom (if no lower stool is fitted) or the top of the lower stool not less than $0,15 l$.

The thicknesses of the middle part of corrugations considered in the application of [2.4.2] and [2.4.4] are to be maintained to a distance from the deck (if no upper stool is fitted) or the bottom of the upper stool not greater than $0,3 l$.

2.4.2 Bending capacity and shear stress τ

The bending capacity is to comply with the following relationship:

$$10^3 \frac{M}{0,5 Z_{le} \sigma_{a,le} + Z_m \sigma_{a,m}} \leq 1,0$$

where:

M : Bending moment, in kN.m, as given in [2.3.2]

Z_{le} : Section modulus of one half pitch corrugation, in cm^3 , at the lower end of corrugations, to be calculated according to [2.4.3]

Z_m : Section modulus of one half pitch corrugation, in cm^3 , at the mid-span of corrugations, to be calculated according to [2.4.4]

$\sigma_{a,le}$: Allowable stress, in N/mm^2 , as given in [2.4.5], for the lower end of corrugations

$\sigma_{a,m}$: Allowable stress, in N/mm^2 , as given in [2.4.5], for the mid-span of corrugations.

In no case is Z_m to be taken greater than the lesser of $1,15 Z_{le}$ and $1,15 Z'_{le}$ for calculation of the bending capacity, Z'_{le} being defined below.

Where effective shedders plates are fitted which:

- are not knuckled
- are welded to the corrugations and the top of the lower stool by one side penetration welds or equivalent
- are fitted with a minimum slope of 45° and their lower edge is in line with the stool side plating,

or effective gusset plates are fitted which:

- are fitted in line with the stool side plating
- have material properties at least equal to those provided for the flanges,

the section modulus Z_{le} , in cm^3 , is to be taken not larger than the value Z'_{le} , in cm^3 , given by:

$$Z'_{le} = Z_g + 10^3 \frac{Q h_g - 0,5 h_g^2 s_1 p_g}{\sigma_a}$$

where:

Z_g : Section modulus of one half pitch corrugation, in cm^3 , according to [2.4.4], in way of the upper end of shedder or gusset plates, as applicable

Q : Shear force, in kN, as given in [2.3.3]

h_g : Height, in m, of shedders or gusset plates, as applicable (see Fig 4, Fig 5, Fig 6, Fig 7 and Fig 8)

s_1 : As given in [2.2.3], item a)

p_g : Resultant pressure, in kN/m^2 , as defined in [2.2.6] and [2.2.7], calculated in way of the middle of the shedders or gusset plates, as applicable

σ_a : Allowable stress, in N/mm^2 , as given in [2.4.5].

Stresses τ are obtained by dividing the shear force Q by the shear area. The shear area is to be reduced in order to account for possible non-perpendicularity between the corrugation webs and flanges. In general, the reduced shear area may be obtained by multiplying the web sectional area by $(\sin\phi)$, ϕ being the angle between the web and the flange.

When calculating the section moduli and the shear area, the net plate thicknesses are to be used.

The section moduli of corrugations are to be calculated on the basis of the requirements given in [2.4.3] and [2.4.4].

2.4.3 Section modulus at the lower end of corrugations

The section modulus is to be calculated with the compression flange having an effective flange width, b_{ef} , not larger than as given in [2.4.6].

If the corrugation webs are not supported by local brackets below the stool top (or below the inner bottom) in the lower part, the section modulus of the corrugations is to be calculated considering the corrugation webs 30% effective.

a) Provided that effective shedder plates, as defined in [2.4.2], are fitted (see Fig 4 and Fig 5), when calculating the section modulus of corrugations at the lower end (cross-section 1 in Fig 4 and Fig 5, the area of flange plates, in cm^2 , may be increased by the following value (which is not to be taken greater than $2,5 a t_f$):

$$2,5 a \sqrt{t_f t_{sh}} \sqrt{\frac{\sigma_{Fsh}}{\sigma_{Ffl}}}$$

where:

a : Width, in m, of the corrugation flange (see Fig 2)

t_{sh} : Net shedder plate thickness, in mm

t_f : Net flange thickness, in mm

σ_{Fsh} : Minimum upper yield stress, in N/mm^2 , of the material used for the shedder plate

σ_{Ffl} : Minimum upper yield stress, in N/mm^2 , of the material used for the corrugation flanges.

Figure 4 : Symmetrical shedder plates

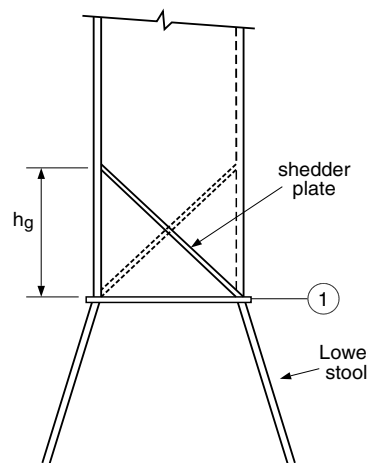
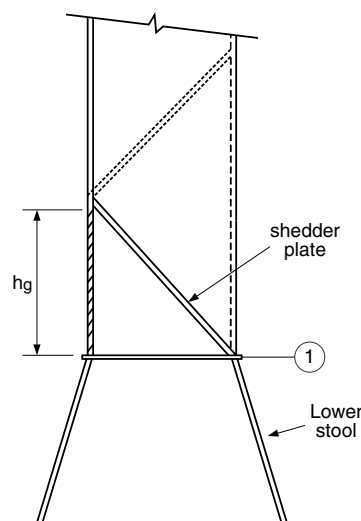


Figure 5 : Asymmetrical shedder plates



b) Provided that effective gusset plates, as defined in [2.4.2], are fitted (see Fig 6, Fig 7 and Fig 8) when calculating the section modulus of corrugations at the lower end (cross-section 1 in Fig 6, Fig 7 and Fig 8), the area of flange plates, in cm^2 , may be increased by $7 h_g t_{gu}$, where:

h_g : Height of gusset plate in m, see Fig 6, Fig 7 and Fig 8, not to be taken greater than $s_{gu} / 0,7$

s_{gu} : Width of the gusset plates, in mm

t_{gu} : Net gusset plate thickness, in mm, not to be taken greater than t_f

t_f : Net flange thickness, in mm, based on the as-built condition.

c) If the corrugation webs are welded to a sloping stool top plate, which is at an angle not less than 45° with the horizontal plane, the section modulus of the corrugations may be calculated considering the corrugation webs fully effective. Where effective gusset plates are fitted, when calculating the section modulus of corrugations the area of flange plates may be increased as specified in b) above. No credit can be given to shedder plates only.

For angles less than 45°, the effectiveness of the web may be obtained by linear interpolation between 30% for 0° and 100% for 45°.

Figure 6 : Symmetrical gusset/shedder plates

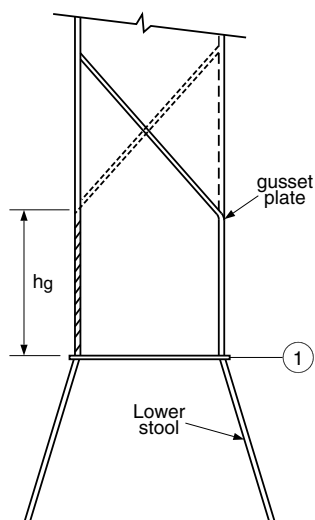


Figure 7 : Asymmetrical gusset/shedder plates

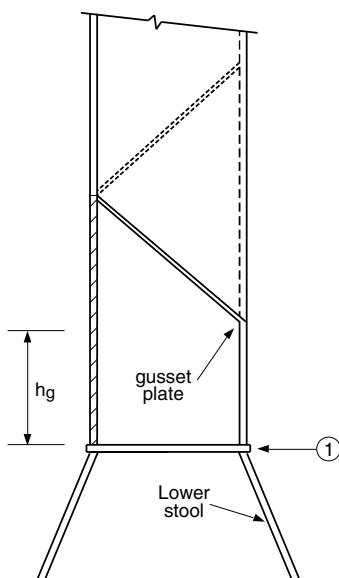
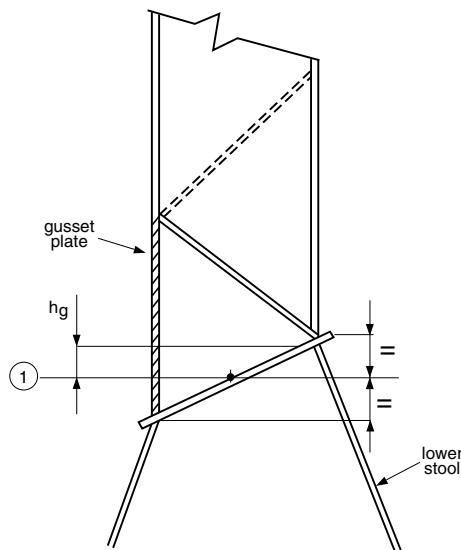


Figure 8 : Asymmetrical gusset/shedder plates Sloping stool top plate



2.4.4 Section modulus of corrugations at cross-sections other than the lower end

The section modulus is to be calculated with the corrugation webs considered effective and the compression flange having an effective flange width not larger than as given in [2.4.6].

2.4.5 Allowable stress check

The normal and shear stresses σ and τ are not to exceed the allowable values σ_a and τ_a , in N/mm², given by:

$$\sigma_a = \sigma_F$$

$$\tau_a = 0,5 \sigma_F$$

where:

σ_F : Minimum upper yield stress, in N/mm², of the material.

2.4.6 Effective width of the compression flange of corrugations

The effective width b_{ef} , in m, of the corrugation flange is given by:

$$b_{ef} = C_e a$$

where:

$$C_e = \frac{2,25}{\beta} - \frac{1,25}{\beta^2} \quad \text{for } \beta > 1,25$$

$$C_e = 1 \quad \text{for } \beta \leq 1,25$$

$$\beta = 10^3 \frac{a}{t_f} \sqrt{\frac{\sigma_F}{E}}$$

t_f : Net flange thickness, in mm

a : As given in [2.4.2]

σ_F : Minimum upper yield stress, in N/mm², of the material

E : Modulus of elasticity, in N/mm², to be assumed equal to 206000 N/mm² for steel.

2.4.7 Shear buckling check

The buckling check is to be performed for the web plates at the corrugation ends.

The shear stress τ is not to exceed the critical value τ_c , in N/mm², obtained as follows:

$$\tau_c = \tau_E \quad \text{for } \tau_E \leq \frac{\tau_F}{2}$$

$$\tau_c = \tau_F \left(1 - \frac{\tau_E}{4\tau_F}\right) \quad \text{for } \tau_E > \frac{\tau_F}{2}$$

$$\tau_F = \frac{\sigma_F}{\sqrt{3}}$$

where:

σ_F : Minimum upper yield stress, in N/mm², of the material

$$\tau_E = 0,9k_t E \left(\frac{t}{1000c}\right)^2$$

$$k_t = 6,34$$

E : Modulus of elasticity, in N/mm², as given in [2.4.6]

t : Net thickness, in mm, of corrugation web

c : Width, in m, of corrugation web (see Fig 2).

2.4.8 Local net plate thickness

The bulkhead local net plate thickness t , in mm, is given by:

$$t = 14,9s_w \sqrt{\frac{p}{\sigma_F}}$$

where:

s_w : Plate width, in m, to be taken equal to the width of the corrugation flange or web, whichever is the greater (see Fig 2)

p : Resultant pressure, in kN/m², as defined in [2.2.6] and [2.2.7], at the bottom of each strake of plating; in all cases, the net thickness of the lowest strake is to be determined using the resultant pressure at the top of the lower stool or at the inner bottom, if no lower stool is fitted, or at the top of shedders, if shedder or gusset/shedder plates are fitted

σ_F : Minimum upper yield stress, in N/mm², of the material.

For built-up corrugation bulkheads, when the thicknesses of the flange and web are different, the net thickness of the narrower plating is to be not less than t_n , in mm, given by:

$$t_n = 14,9s_n \sqrt{\frac{p}{\sigma_F}}$$

where:

s_n : Width, in m, of the narrower plating.

The net thickness of the wider plating, in mm, is not to be taken less than the maximum of the following values:

$$t_w = 14,9s_w \sqrt{\frac{p}{\sigma_F}}$$

$$t_w = \sqrt{\frac{440s_w^2 p}{\sigma_F} - t_{np}^2}$$

where:

t_{np} : Thickness, in mm, less or equal to the actual net thickness of the narrower plating and not to be greater than:

$$14,9s_w \sqrt{\frac{p}{\sigma_F}}$$

2.5 Local details

2.5.1 General

As applicable, the design of local details is to comply with the Society's requirements for the purpose of transferring the corrugated bulkhead forces and moments to the boundary structures, especially to the double bottom and cross-deck structures.

In particular, the thickness and stiffness of gusset and shedder plates, as defined in [2.4.3], installed for strengthening purposes, are to comply with the Society's requirements on the basis of the load model in [2.2].

Unless otherwise stated, weld connections and materials are to be dimensioned and selected in accordance with the Society's requirements.

2.6 Steel renewal

2.6.1 General

Renewal/reinforcement is to be carried out in accordance with the following requirements and the guidelines contained in [3].

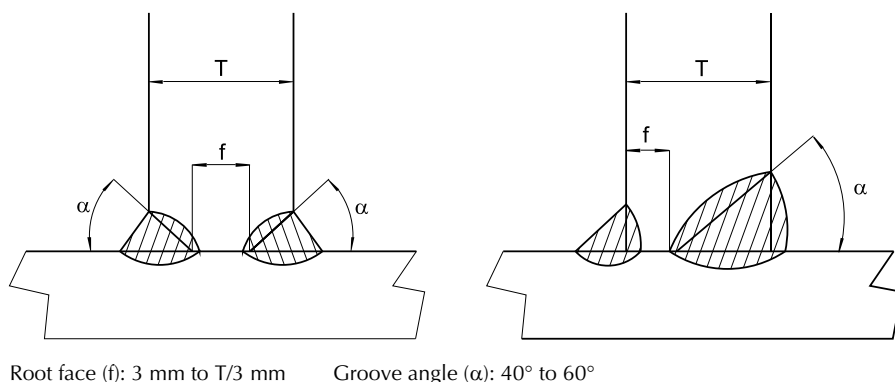
2.6.2 Steel renewal is required where the gauged thickness is less than $(t_{net} + 0,5)$ mm, t_{net} being the thickness used for the calculation of bending capacity and shear stresses as given in [2.4.2] or the local net plate thickness as given in [2.4.8]. Alternatively, reinforcing doubling strips may be used providing the net thickness is not dictated by shear strength requirements for web plates (see [2.4.5] and [2.4.7]) or by local pressure requirements for web and flange plates (see [2.4.8]).

Where steel renewal is required, the bulkhead connections to the lower stool shelf plate (or inner bottom, if no stool is fitted) are to be made at least by deep penetration welds (see Fig 9).

Where the gauged thickness is within the range $(t_{net} + 0,5)$ mm and $(t_{net} + 1,0)$ mm, coating (applied in accordance with the coating Manufacturer's specifications) or annual gauging may be adopted as an alternative to steel renewal.

2.6.3 Where steel renewal or reinforcement is required, a minimum thickness of $(t_{net} + 2,5)$ mm is to be replenished for the renewed or reinforced parts.

Figure 9 : Deep penetration welds of shedder and gusset plates



2.6.4 Gussets with shedder plates, extending from the lower end of corrugations up to $0,1 \ell$, or reinforcing doubling strips (on bulkhead corrugations and stool side plating) are to be fitted when:

$$\frac{\sigma_{Fs} t_{st}}{\sigma_{Ffl} t_{fl}} \leq 0,8$$

where:

σ_{Ffl} : Minimum upper yield stress, in N/mm^2 , of the material used for the corrugation flanges

σ_{Fs} : Minimum upper yield stress, in N/mm^2 , of the material used for the lower stool side plating (or floors, if no stool is fitted)

t_{fl} : Flange thickness, in mm, which is found to be acceptable on the basis of the criteria specified in [2.6.2] or, when steel renewal is required, the replenished thickness according to the criteria specified in [2.6.3]. The above flange thickness dictated by local pressure requirements (see [2.4.8]) need not be considered for this purpose

t_{st} : As-built thickness, in mm, of the lower stool side plating (or floors, if no stool is fitted).

If gusset plates are fitted, their material is to be the same as that of the corrugation flanges. The gusset plates are to be connected to the lower stool shelf plate (or inner bottom, if no lower stool is fitted) by deep penetration welds (see Fig 9).

Where gusset plates are to be fitted or renewed, their connections with the corrugations and the lower stool shelf plate (or inner bottom, if no stool is fitted) are to be made at least by deep penetration welds (see Fig 9).

3 Guidance on renewal/reinforcement of the transverse watertight vertically corrugated bulkhead between the two foremost cargo holds

3.1

3.1.1 The need for renewal or reinforcement of the transverse watertight vertically corrugated bulkhead between the two foremost cargo holds will be determined by the Society on a case-by-case basis using the criteria given in [2] in association with the most recent gaugings and survey findings.

3.1.2 In addition to Rule requirements, the assessment of the transverse corrugated bulkhead based on the criteria given in [2] will take into account the following:

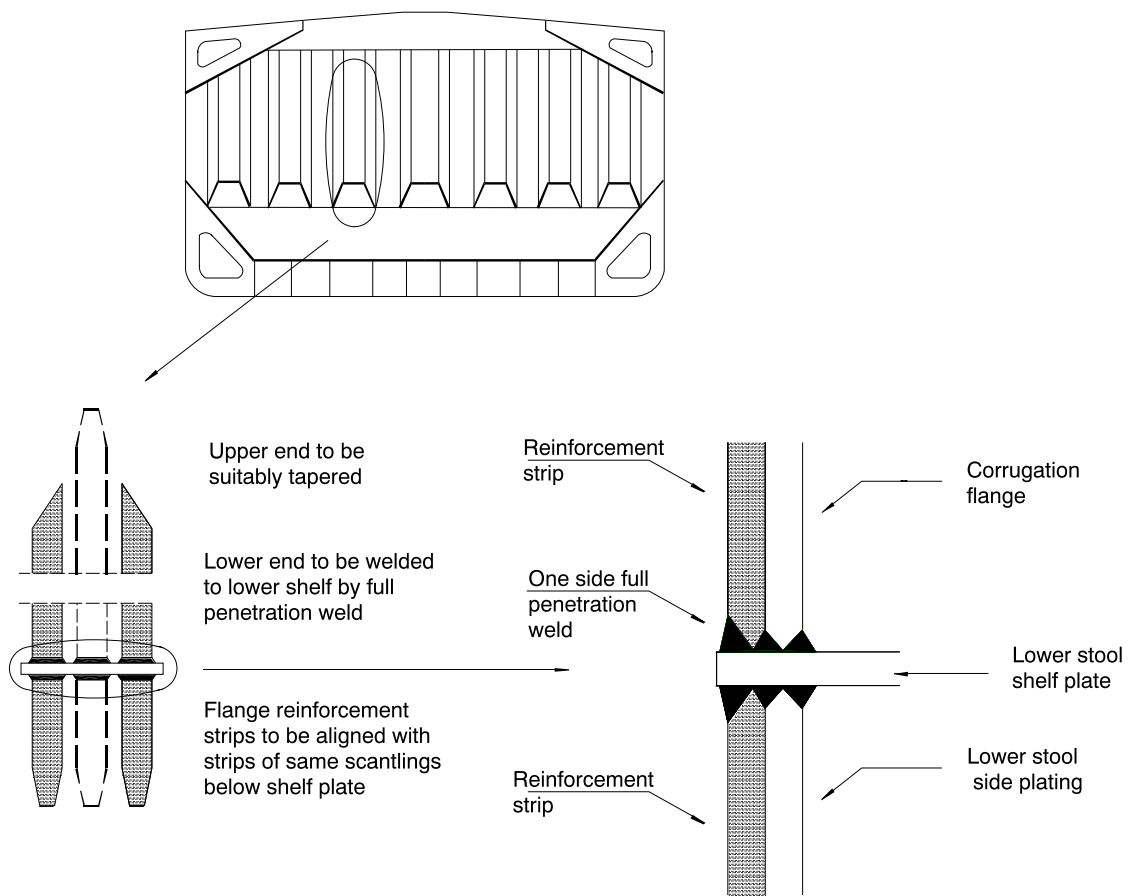
- scantlings of individual vertical corrugations will be assessed for reinforcement/renewal based on thickness measurements obtained in accordance with Ch 6, Sec 2, [1.3] at their lower end, at mid-depth and in way of plate thickness changes in the lower 70%. These considerations will take into account the provision of gussets and shedder plates and the benefits they offer, provided that they comply with [2.4.2] and [2.6].
- taking into account the scantlings and arrangements for each case, permissible levels of diminution will be determined and appropriate measures taken in accordance with [2.6].

3.1.3 Where renewal is required, its extent is to be shown clearly in plans. The vertical distance of each renewal zone is to be determined by considering the criteria given in [2] and is generally to be not less than 15% of the vertical distance between the upper and lower end of the corrugation measured at the ship's centreline.

3.1.4 Where the reinforcement is accepted by adding strips, the length of the reinforcing strips is to be sufficient to extend over the whole depth of the diminished plating. In general, the width and thickness of strips are to be sufficient to comply with the criteria given in [2]. The material of the strips is to be the same as that of the corrugation plating. The strips are to be attached to the existing bulkhead plating by continuous fillet welds. The strips are to be suitably tapered or connected at ends in accordance with the usual welding practice to the Surveyor's satisfaction.

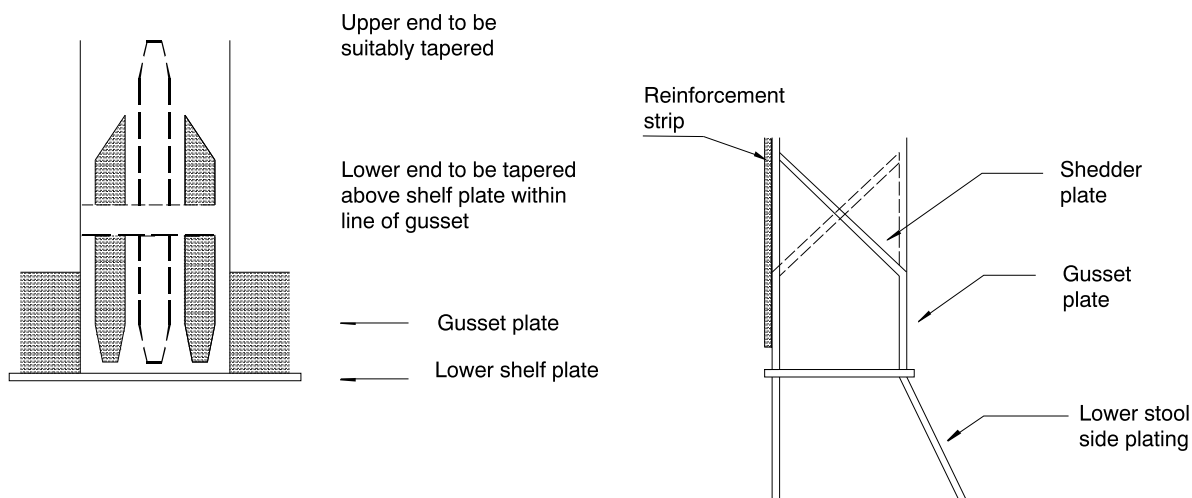
3.1.5 Where reinforcing strips are connected to the inner bottom or lower stool shelf plates, one side full penetration welding is to be used. When reinforcing strips are fitted to the corrugation flange and are connected to the lower stool shelf plate, they are normally to be aligned with strips of the same scantlings welded to the stool side plating and having a minimum length equal to the breadth of the corrugation flange.

Figure 10 : Reinforcement of vertically corrugated bulkhead



Reinforcement strips with shedder plate

Weld of reinforcement strip to shelf plate



Reinforcement strips with shedder and gusset plates

3.1.6 Fig 10 gives a general arrangement of structural reinforcement. When such reinforcement is carried out, the following applies:

- square or trapezoidal corrugations are to be reinforced with plate strips fitted to each corrugation flange sufficient to meet the requirements given in [2]
- the number of strips fitted to each corrugation flange is to be sufficient to meet the requirements given in [2]
- the shedder plate may be fitted in one piece or prefabricated with a welded knuckle (gusset plate)
- gusset plates, where fitted, are to be welded to the shelf plate in line with the flange of the corrugation, to reduce the stress concentrations at the corrugation corners. Good alignment is to be ensured between gusset plates, corrugation flanges and lower stool sloping plates. Deep penetration welding is to be used at all connections. Start and stop of welding are to be as far away as possible from corners of corrugations
- shedder plates are to be attached by one side full penetration welds onto backing bars
- shedder and gusset plates are to have a thickness equal to or greater than the original bulkhead thickness. Gusset plates are to have a minimum height (on the vertical part) equal to half of the width of the corrugation flange. Sheddors and gussets are to be of the same material as that of the flange.

4 Evaluation of allowable hold loading of the foremost cargo hold with the same cargo hold flooded

4.1 Application and definitions

4.1.1 These requirements apply to bulk carriers:

- of single side skin construction
- of 150 metres in length and above
- intended to carry solid bulk cargoes having a bulk density of 1,78 t/m³ or above

- contracted for construction prior to 1st July 1998, and not constructed in compliance with the applicable requirements for new buildings contracted after that date, and given in Pt D, Ch 4, Sec 3.

4.1.2 The loading in the foremost cargo hold is not to exceed the allowable hold loading in the flooded condition, calculated as per [4.4], using the loads given in [4.2] and the shear capacity of the double bottom given in [4.3].

In no case is the allowable hold loading in flooding condition to be taken greater than the design hold loading in intact condition.

4.2 Load model

4.2.1 General

The loads to be considered as acting on the double bottom of the foremost cargo hold are those given by the external sea pressures and the combination of the cargo loads with those induced by the flooding of the foremost cargo hold itself.

The most severe combinations of cargo induced loads and flooding loads are to be used, depending on the loading conditions included in the loading manual:

- homogeneous loading conditions
- non-homogeneous loading conditions
- packed cargo conditions, such as steel mill products.

For each loading condition, the maximum bulk cargo density to be carried is to be considered in calculating the allowable hold limit.

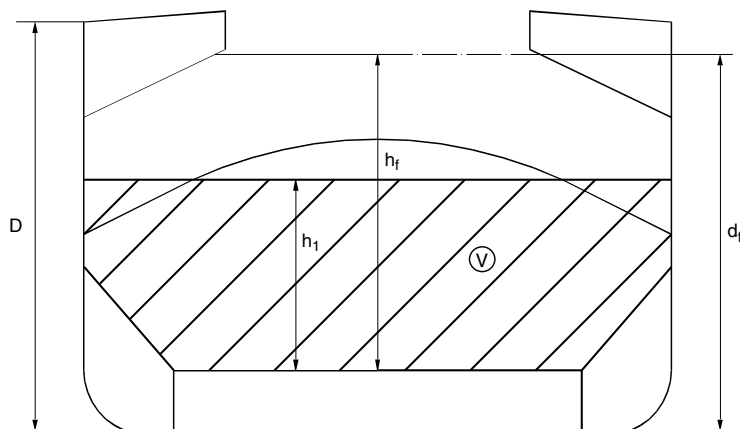
4.2.2 Inner bottom flooding head

The flooding head h_f (see Fig 11) is the distance, in m, measured vertically with the ship in the upright position, from the inner bottom to a level located at a distance d_f , in m, from the base line equal to:

- D in general
- $0,95 D$ for ships less than 50,000 tonnes deadweight with type B freeboard,

D being the distance, in m, from the base line to the freeboard deck at side amidships (see Fig 11).

Figure 11 : Calculation of pressure on the inner bottom in the flooded cargo hold



V = Volume of cargo

4.3 Shear capacity of the double bottom of the foremost cargo hold

4.3.1 General

The shear capacity C of the double bottom of the foremost cargo hold is defined as the sum of the shear strength at each end of:

- all floors adjacent to both hoppers, less one half of the strength of the two floors adjacent to each stool, or transverse bulkhead if no stool is fitted (see Fig 12)
- all double bottom girders adjacent to both stools, or transverse bulkheads if no stool is fitted.

The strength of girders or floors which run out and are not directly attached to the boundary stool or hopper girder is to be evaluated for the one end only.

Note 1: The floors and girders to be considered are those inside the hold boundaries formed by the hoppers and stools (or transverse bulkheads if no stool is fitted). The hopper side girders and the floors directly below the connection of the bulkhead stools (or transverse bulkheads if no stool is fitted) to the inner bottom are not to be included.

Note 2: When the geometry and/or the structural arrangement of the double bottom is such as to make the above assumptions inadequate, at the Society's discretion, the shear capacity C of the double bottom is to be calculated by means of direct calculations to be carried out according to Pt B, Ch 7, App 1, as far as applicable.

In calculating the shear strength, the net thicknesses of floors and girders are to be used. The net thickness t_{net} , in mm, is given by:

$$t_{net} = t - t_c$$

where:

t : As-built thickness, in mm, of floors and girders

t_c : Corrosion diminution, equal to 2 mm, in general; a lower value of t_c may be adopted, provided that measures are taken, to the Society's satisfaction, to justify the assumption made.

4.3.2 Floor shear strength

The floor shear strength in way of the floor panel adjacent to hoppers S_{f1} , in kN, and the floor shear strength in way of the openings in the outermost bay (i.e. that bay which is closest to the hopper) S_{f2} , in kN, are given by the following expressions:

$$S_{f1} = 10^{-3} A_f \frac{\tau_a}{\eta_1}$$

$$S_{f2} = 10^{-3} A_{f,h} \frac{\tau_a}{\eta_2}$$

where:

A_f : Sectional area, in mm², of the floor panel adjacent to hoppers

$A_{f,h}$: Net sectional area, in mm², of the floor panels in way of the openings in the outermost bay (i.e. that bay which is closest to the hopper)

τ_a : Allowable shear stress, in N/mm², to be taken equal to:

$$\tau_a = \frac{\sigma_F}{\sqrt{3}}$$

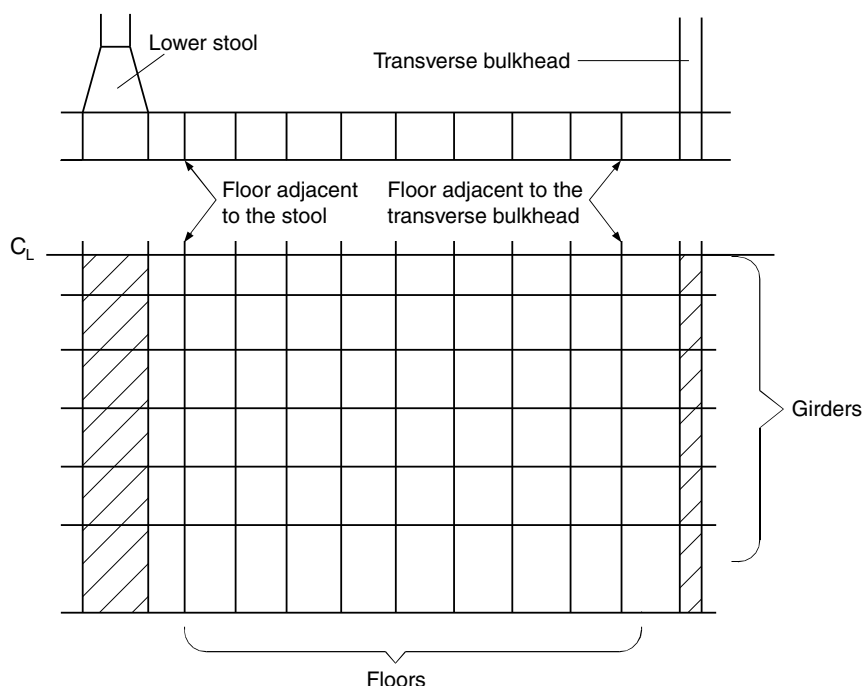
σ_F : Minimum upper yield stress, in N/mm², of the material

η_1 : $\eta_1 = 1,10$

η_2 : $\eta_2 = 1,20$

η_2 may be reduced, at the Society's discretion, down to 1,10 where appropriate reinforcements are fitted to the Society's satisfaction.

Figure 12 : Double bottom structure



4.3.3 Girder shear strength

The girder shear strength in way of the girder panel adjacent to stools (or transverse bulkheads, if no stool is fitted) S_{g1} , in kN, and the girder shear strength in way of the largest opening in the outermost bay (i.e. that bay which is closest to the stool, or transverse bulkhead, if no stool is fitted) S_{g2} , in kN, are given by the following expressions:

$$S_{g1} = 10^{-3} A_g \frac{\tau_a}{\eta_1}$$

$$S_{g2} = 10^{-3} A_{g,h} \frac{\tau_a}{\eta_2}$$

where:

- A_g : Minimum sectional area, in mm², of the girder panel adjacent to stools (or transverse bulkheads if no stools are fitted)
- $A_{g,h}$: Net sectional area, in mm², of the girder panel in way of the largest opening in the outermost bay (i.e. that bay which is closest to the stool, or transverse bulkhead, if no stool is fitted)
- τ_a : Allowable shear stress, in N/mm², as given in [4.3.2]
- η_1 : $\eta_1 = 1,10$
- η_2 : $\eta_2 = 1,15$
 η_2 may be reduced, at the Society's discretion, down to 1,10 where appropriate reinforcements are fitted to the Society's satisfaction.

4.4 Allowable hold loading

4.4.1 The allowable hold loading W , in t, is given by:

$$W = \rho_c V \frac{1}{F}$$

where:

- F : Equal to 1,05 in general (for steel mild products, $F = 1,0$)
- ρ_c : Cargo density, in t/m³; for bulk cargoes see [4.2.1]; for steel products, ρ_c is to be taken as the density of steel
- V : Volume, in m³, occupied by cargo at a level h_1 given by:

$$h_1 = \frac{X}{\rho_c g}$$

where:

- X : For bulk cargoes, is the lesser of X_1 and X_2 given by:

$$X_1 = \frac{Z + \rho g (E - h_i)}{1 + \frac{\rho}{\rho_c} (\text{perm} - 1)}$$

$$X_2 = Z + \rho g (E - h_i \text{perm})$$

Note 1: For steel products, X may be taken equal to X_1 , using $\text{perm} = 0$

- ρ : Sea water density, in t/m³
- g : 9,81 m/s², gravity acceleration

- E : $E = d_f - 0,1 D$
with d_f and D as given in [4.2.2]
- h_f : Flooding head, in m, as defined in [4.2.2]
- perm : Permeability of cargo, to be taken as 0,3 for ore (corresponding bulk cargo density for iron ore may generally be taken as 3,0 t/m³)
- Z : The lesser of Z_1 and Z_2 given by:
$$Z_1 = \frac{C_h}{A_{DB,h}}$$

$$Z_2 = \frac{C_e}{A_{DB,e}}$$

with:

- C_h : Shear capacity of the double bottom, in kN, as defined in [4.3], considering, for each floor, the lesser of the shear strengths S_{f1} and S_{f2} (see [4.3.2]) and, for each girder, the lesser of the shear strengths S_{g1} and S_{g2} (see [4.3.3])
- C_e : Shear capacity of the double bottom, in kN, as defined in [4.3], considering, for each floor, the shear strength S_{f1} (see [4.3.2]) and, for each girder, the lesser of the shear strengths S_{g1} and S_{g2} (see [4.3.3])

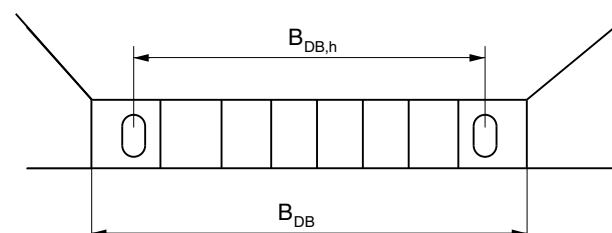
$$A_{DB,h} : A_{DB,h} = \sum_{i=1}^{i=n} S_i B_{DB,i}$$

$$A_{DB,e} : A_{DB,e} = \sum_{i=1}^{i=n} S_i (B_{DB} - s)$$

where:

- n : Number of floors between stools (or transverse bulkheads, if no stools are fitted)
- S_i : Space of the i th-floor, in m
- $B_{DB,i}$:
 - for floors whose shear strength is given by S_{f1} (see [4.3.2]): $B_{DB,i} = B_{DB} - s$
 - for floors whose shear strength is given by S_{f2} (see [4.3.2]): $B_{DB,i} = B_{DB,h}$
 where $B_{DB,h}$ is the distance, in m, between the two openings considered (see Fig 13)
- B_{DB} : Breadth of double bottom, in m, between hoppers (see Fig 13)
- s : Spacing, in m, of double bottom longitudinals adjacent to hoppers.

Figure 13 : Dimensions B_{DB} and $B_{DB,h}$



5 Renewal criteria for side shell frames and brackets in single side skin bulk carriers and single side skin OBO carriers not built in accordance with Part II, Chapter 8, Section 8-03 of the 1st April 1998 edition of the Rules or subsequent editions

5.1 Application and symbols

5.1.1 These retroactive rule requirements apply to:

- the side shell frames and brackets of cargo holds bounded by the single side shell of ships with service notation **bulk carrier ESP** constructed with single deck, topside tanks and hopper tanks in cargo spaces intended primarily to carry dry cargo in bulk
- the side shell frames and brackets of cargo holds bounded by the single side shell of ships with service notation **combination carrier/OBO ESP** as defined in Ch 1, Sec 2, [4.3.4] but of single side skin construction,

which were not built in accordance with the applicable requirements of Part II, Chapter 8, Section 8-03 of the 1st April 1998 edition of the Rules or subsequent editions.

5.1.2 Symbols

- t_M : Thickness as measured, in mm
- t_{REN} : Thickness at which renewal is required. Refer to [5.3.1]
- $t_{REN,d/t}$: Thickness criteria based on d/t ratio. Refer to [5.3.2]
- $t_{REN,S}$: Thickness criteria based on strength. Refer to [5.3.3]
- t_{COAT} : $t_{COAT} = 0,75 t_{S12}$
- t_{S12} : Thickness, in mm, as required in Tab 1 for side frame webs and upper and lower end bracket webs
- t_{AB} : Thickness as built, in mm
- t_C : As defined in Tab 2.

5.2 Ice strengthened ships

5.2.1 Where bulk carriers are reinforced to comply with an ice class notation, the intermediate frames are not to be included when considering compliance with the present Article.

5.2.2 The renewal thicknesses for the additional structure required to meet the ice strengthening notation are to be based on the Society's requirements.

5.2.3 If the ice class notation is requested to be withdrawn, the additional ice strengthening structure, with the exception of tripping brackets as required in [5.3.2], item b) and [5.4.2], is not to be considered to contribute to compliance with the present Article.

5.3 Criteria for renewal

5.3.1 General

The webs of side shell frames and brackets are to be renewed when the measured thickness (t_M) is equal to or less than the thickness (t_{REN}) as defined below:

- t_{REN} : The greatest of:
- $t_{COAT} - t_C$
 - $0,75 t_{AB}$
 - $t_{REN,d/t}$ (applicable to Zone A and B only) as defined in [5.3.2]
 - $t_{REN,S}$ where required by [5.3.3] and as defined in [5.5.4].

The measures are given in [5.3.4] and [5.3.5].

The criteria for frames and brackets are given in [5.3.6].

Table 1 : t_{S12} values, in mm

Item	Thickness t_{S12}
Side frame webs	$C_L (7,0 + 0,03 L_1)$
Lower end brackets	The greater of: <ul style="list-style-type: none"> $C_L (7,0 + 0,03 L_1) + 2$ as-built thickness of side frame web
Upper end brackets	The greater of: <ul style="list-style-type: none"> $C_L (7,0 + 0,03 L_1)$ as-built thickness of side frame web
Note 1:	
C_L	: Coefficient equal to: <ul style="list-style-type: none"> 1,15 for side frames in way of the foremost cargo hold 1,0 for side frames in way of other cargo holds
L_1	: Ship's length, in m, defined in Pt B, Ch 1, Sec 2, [2].

Table 2 : t_c values, in mm

Ship's length L, in m	Holds other than No.1		Hold No.1	
	Span and upper brackets	Lower brackets	Span and upper brackets	Lower brackets
≤ 100	2,0	2,5	2,0	3,0
150	2,0	3,0	3,0	3,5
≥ 200	2,0	3,0	3,0	4,0

Note: For intermediate ship lengths, t_c is obtained by linear interpolation between the above values.

5.3.2 Thickness criteria based on d/t ratio

Subject to items b) and c) below $t_{REN,d/t}$ is given by the following formula:

$$t_{REN,d/t} = \frac{d}{R}$$

where:

d : Web depth, in mm

R : Coefficient given as follows:

- frames:
 - 65 $k^{0.5}$ for symmetrically flanged frames
 - 55 $k^{0.5}$ for asymmetrically flanged frames
- lower brackets (see item a) below):
 - 87 $k^{0.5}$ for symmetrically flanged frames
 - 73 $k^{0.5}$ for asymmetrically flanged frames

k : Coefficient given in Pt B, Ch 4, Sec 1, [2.3]

k = 1 for ordinary hull structural steel.

In no instance is $t_{REN,d/t}$ for lower integral brackets to be taken as less than $t_{REN,d/t}$ for the frames they support.

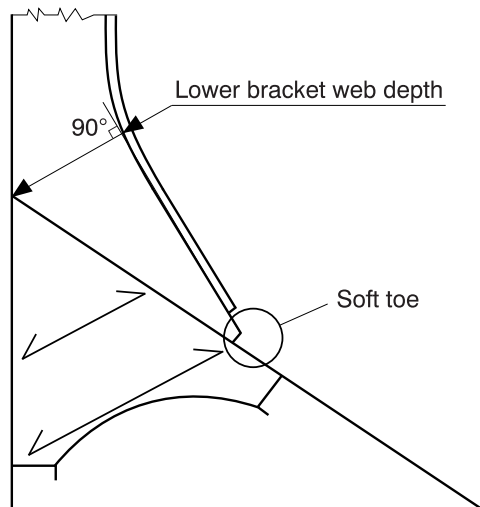
a) Lower brackets

Lower brackets are to be flanged or face plate is to be fitted. Refer to [5.3.6].

In calculating the web depth of the lower brackets, the following items apply:

- The web depth of lower bracket may be measured from the intersection of the sloped bulkhead of the hopper tank and the side shell plate, perpendicularly to the face plate of the lower bracket (refer to Fig 14)
- Where stiffeners are fitted on the lower bracket plate, the web depth may be taken as the distance between the side shell and the stiffener, between the stiffeners or between the outermost stiffener and the face plate of the brackets, whichever is the greatest.

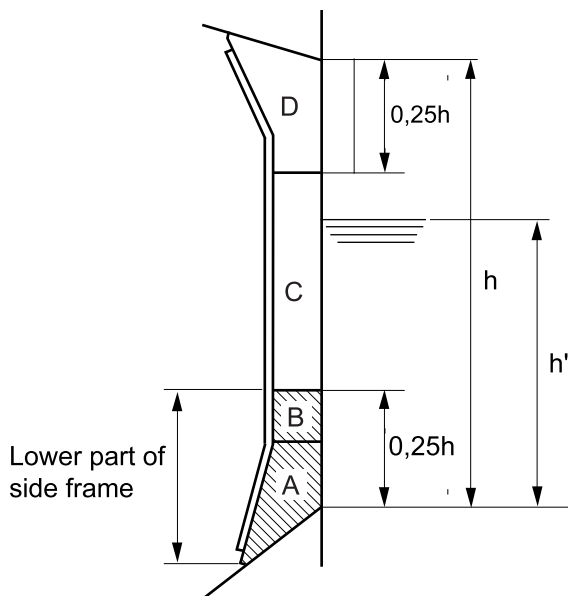
Figure 14 : Definition of the lower bracket web depth for determining $t_{REN,d/t}$



b) Tripping bracket alternative

When t_M is less than $t_{REN,d/t}$ at section b) of the side frames, tripping brackets in accordance with [5.4.2] may be fitted as an alternative to the requirements for the web depth to thickness ratio of side frames, in which case $t_{REN,d/t}$ may be disregarded in the determination of t_{REN} in accordance with [5.3.1]. The value of t_M is to be based on zone B according to Fig 15.

Figure 15 : Lower part and zones of side frames



c) Immediately abaft collision bulkhead

For the side frames, including the lower bracket, located immediately abaft the collision bulkhead, whose scantlings are increased in order that their moment of inertia is such to avoid undesirable flexibility of the side shell, when their web as built thickness t_{AB} is greater than $1,65t_{REN,S}$ the thickness $t_{REN,d/t}$ may be taken as the value $t'_{REN,d/t}$ obtained from the following formula:

$$t'_{REN,d/t} = \sqrt[3]{t_{REN,d/t}^2 \cdot t_{REN,S}}$$

where $t_{REN,S}$ is obtained from [5.5.4].

5.3.3 Thickness criteria based on shear strength check

Where t_M in the lower part of side frames, as defined in Fig 15, is equal to or less than t_{COAT} , $t_{REN,S}$ is to be determined in accordance with [5.5.4].

5.3.4 Thickness of renewed webs of frames and lower brackets

Where steel renewal is required, the renewed webs are to be of a thickness not less than t_{AB} , $1,2t_{COAT}$ or $1,2t_{REN}$, whichever is the greatest.

5.3.5 Criteria for other measures

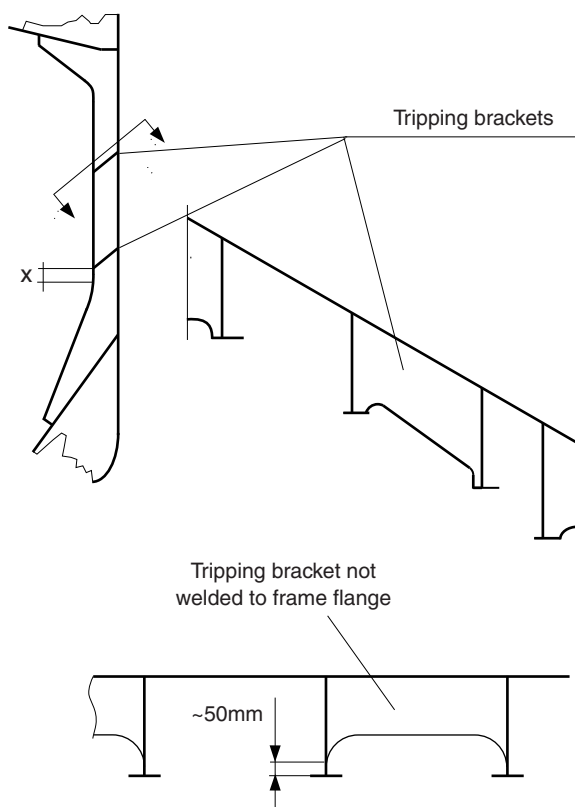
When $t_{REN} < t_M \leq t_{COAT}$, measures are to be taken, consisting of all the following items:

- sand blasting, or equivalent, and coating (refer to [5.4.1])
- Fitting tripping brackets (refer to [5.4.2]), when the above condition occurs for any of the side frame zones A, B, C and D, as shown in Fig 15. Tripping brackets not connected to flanges are to have soft toe, and the distance between the bracket toe and the frame flange is not to be greater than about 50 mm, see Fig 16, and
- Maintaining the coating in “as-new” condition (i.e. without breakdown or rusting) at class renewal and intermediate surveys.

The above measures may be waived if the structural members show no thickness diminution with respect to the as built thicknesses and coating is in “as-new” condition (i.e. without breakdown or rusting).

When the measured frame webs thickness t_M is such that $t_{REN} < t_M \leq t_{COAT}$ and the coating is in GOOD condition, sand blasting and coating as required in a) above may be waived even if not found in “as-new” condition, as defined above, provided that tripping brackets are fitted and the coating damaged in way of the tripping bracket welding is repaired.

Figure 16 : Tripping brackets



x : Distance from knuckle not greater than 200 mm.

5.3.6 Criteria for frames and brackets (bending check)

When lower end brackets were not fitted with flanges at the design stage, flanges are to be fitted so as to meet the bending strength requirements in [5.5.5]. The full width of the bracket flange is to extend up beyond the point at which the frame flange reaches full width. Adequate back-up structure in the hopper is to be ensured, and the bracket is to be aligned with the back-up structure.

Where the length or depth of the lower bracket does not meet the requirements in Pt D, Ch 4, Sec 3, [2.2.6], a bending strength check in accordance with [5.5.5] is to be carried out and renewals or reinforcements of frames and/or brackets effected as required therein.

The bending check needs not to be carried out in the case the bracket geometry is modified so as to comply with Pt D, Ch 4, Sec 3, [2.2.6] requirements.

5.4 Other measures

5.4.1 Thickness measurements, steel renewal, sand blasting and coating

For the purpose of steel renewal, sand blasting and coating, four zones A, B, C and D are defined, as shown in Fig 15. When renewal is to be carried out, surface preparation and coating are required for the renewed structures as given in Pt D, Ch 4, Sec 3, [7.1] for cargo holds of new buildings.

Representative thickness measurements are to be taken for each zone and are to be assessed against the criteria in [5.3].

When zone B is made up of different plate thicknesses, the lesser thickness is to be used for the application of the requirements in this Article [5].

In case of integral brackets, when the criteria in [5.3] are not satisfied for zone A or B, steel renewal, sand blasting and coating, as applicable, are to be done for both zones A and B.

In case of separate brackets, when the criteria in [5.3] are not satisfied for zone A or B, steel renewal, sand blasting and coating is to be done for each one of these zones, as applicable.

When steel renewal is required for zone C according to [5.3], it is to be done for both zones B and C. When sand blasting and coating is required for zone C according to [5.3], it is to be done for zones B, C and D.

When steel renewal is required for zone D according to [5.3], it needs only to be done for this zone. When sand blasting and coating is required for zone D according to [5.3], it is to be done for both zones C and D.

Special consideration may be given by the Society to zones previously renewed or recoated, if found in “as-new” condition (i.e. without breakdown or rusting).

When adopted, on the basis of the renewal thickness criteria in [5.3], in general coating is to be applied in compliance with the requirements of Ch 4, Sec 2, [1.1.7], as applicable.

Where, according to the requirements in [5.3], a limited number of side frames and brackets are shown to require coating over part of their length, the following criteria apply:

- a) The part to be coated includes:
 - the web and the face plate of the side frames and brackets,
 - the hold surface of side shell, hopper tank and top-side tank plating, as applicable, over a width not less than 100 mm from the web of the side frame.
- b) Epoxy coating or equivalent is to be applied.

In all cases, all the surfaces to be coated are to be sand blasted prior to coating application.

When flanges of frames or brackets are to be renewed according to the retroactive rule requirements, the outstanding breadth to thickness ratio is to comply with Pt D, Ch 4, Sec 3, [2.2.4] and Pt D, Ch 4, Sec 3, [2.2.5].

5.4.2 Reinforcing measures

Reinforcing measures are constituted by tripping brackets, located at the lower part and at midspan of side frames (see Fig 16). Tripping brackets may be located at every two frames, but lower and midspan brackets are to be fitted in line between alternate pairs of frames.

The thickness of the tripping brackets is to be not less than the as-built thickness of the side frame webs to which they are connected.

Double continuous welding is to be adopted for the connections of tripping brackets to the side shell frames and shell plating.

Where side frames and side shell are made of Higher Strength Steel (HSS), Normal Strength Steel (NSS) tripping brackets may be accepted, provided the electrodes used for welding are those required for the particular HSS grade, and the thickness of the tripping brackets is equal to the frame web thickness, regardless of the frame web material.

5.4.3 Weld throat thickness

In case of steel renewal the welded connections are to comply with Pt D, Ch 4, Sec 3, [8].

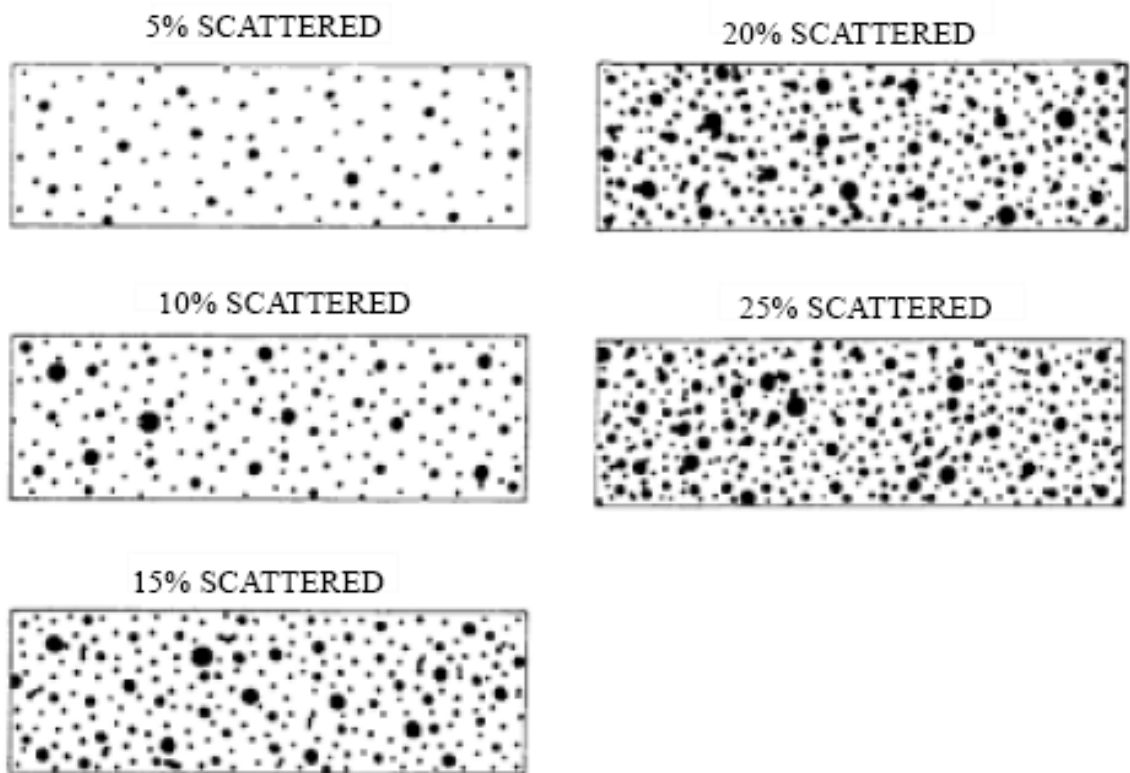
5.4.4 Pitting and grooving

If pitting intensity is higher than 15% in area (see Fig 17), thickness measurement is to be taken to check pitting corrosion.

The minimum acceptable remaining thickness in pits or grooves is equal to:

- 75% of the as built thickness, for pitting or grooving in the frame and brackets webs and flanges
- 70% of the as built thickness, for pitting or grooving in the side shell, hopper tank and topside tank plating attached to the side frame, over a width up to 30 mm from each side of it.

Figure 17 : Pitting intensity diagrams (from 5% to 25% intensity)



5.4.5 Renewal of all frames in one or more cargo holds

When all frames in one or more holds are required to be renewed according to the retroactive rule requirements, the compliance with the applicable requirements of Part II, Chapter 8, Section 8-03 of the first April 1998 edition of the Rules may be accepted in lieu of the compliance with the retroactive rule requirements, provided that:

- It is applied at least to all the frames of the hold(s)
- The coating requirements for side frames of “new ships” are complied with
- The section modulus of side frames is calculated according to the relevant requirements of the Rules.

5.4.6 Renewal of damaged frames

In case of renewal of a damaged frame already complying with this Article [5], the following requirements apply:

- The conditions accepted in compliance with this Article are to be restored as a minimum.
- For localised damages, the extension of the renewal is to be carried out according to the standard practice of the Society.

5.5 Strength check criteria

5.5.1 In general, loads are to be calculated and strength checks are to be carried out for the aft, middle and forward frames of each hold. The scantlings required for frames in intermediate positions are to be obtained by linear interpolation between the results obtained for the above frames.

When scantlings of side frames vary within a hold, the required scantlings are also to be calculated for the mid frame of each group of frames having the same scantlings. The scantlings required for frames in intermediate positions are to be obtained by linear interpolation between the results obtained for the calculated frames.

5.5.2 Load model

The following loading conditions are to be considered:

- homogeneous heavy cargo (density > 1.78 t/m³)
- homogeneous light cargo (density < 1.78 t/m³)
- non homogeneous heavy cargo, if allowed.

Multi port loading/unloading conditions need not be considered.

a) Forces

The forces $P_{fr,a}$ and $P_{fr,b}$, in kN, to be considered for the strength checks at sections a) and b) of side frames (shown in Fig 18, in the case of separate lower brackets, section b) is at the top of the lower bracket), are given by:

$$P_{fr,a} = P_s + \max(P_1, P_2)$$

$$P_{fr,b} = P_{fr,a} \frac{h - 2h_b}{h}$$

where:

P_s : Still water force, in kN.

When the upper end of the side frame span h (see Fig 15) is below the load waterline:

$$P_s = sh \left(\frac{P_{s,u} + P_{s,l}}{2} \right)$$

When the upper end of the side frame span h (see Fig 15) is at or above the load waterline:

$$P_s = sh' \left(\frac{P_{s,l}}{2} \right)$$

P_1 : Wave force, in kN, in head sea, given by the following formula:

$$P_1 = sh \left(\frac{P_{1,u} + P_{1,l}}{2} \right)$$

P_2 : Wave force, in kN, in beam sea, given by the following formula:

$$P_2 = sh \left(\frac{P_{2,u} + P_{2,l}}{2} \right)$$

h : Side frame span, in m, defined in Fig 15

h_b : Lower bracket length, in m, defined in Fig 18

h' : Distance, in m, between the lower end of side frame span h (see Fig 15) and the load waterline

s : Frame spacing, in m

$P_{s,u}$: Still water pressure, in kN/m², at the upper end of the side frame span h (see Fig 15)

$P_{s,l}$: Still water pressure, in kN/m², at the lower end of the side frame span h (see Fig 15)

$P_{1,u}$: Wave pressure, in kN/m², as defined in item b) below, for the upper end of the side frame span h and corresponding to force P_1

$P_{1,l}$: Wave pressure, in kN/m², as defined in item b) below, for the lower end of the side frame span h and corresponding to force P_1

$P_{2,u}$: Wave pressure, in kN/m², as defined in item b) below, for the upper end of the side frame span h and corresponding to force P_2

$P_{2,l}$: Wave pressure, in kN/m², as defined in item b) below, for the lower end of the side frame span h and corresponding to force P_2 .

b) Wave pressures

- Wave pressure p_1

The wave pressure p_1 , in kN/m², at and below the waterline is given by:

$$p_1 = 1,50 \left[p_{11} + 135 \frac{B}{2(B+75)} - (1,2(T-z)) \right]$$

where:

$$P_{11} = 3 k_s C + k_f$$

The wave pressure p_1 , in kN/m², above the waterline is given by:

$$p_1 = p_{1wl} - 7,50 (z - T)$$

• Wave pressure p_2

The wave pressure p_2 , in kN/m^2 , at and below the waterline is given by:

$$p_2 = 13,0 \left[0,5B \frac{50C_r}{2(B+75)} + C_b \frac{0,5B + k_r}{14} \left(0,7 + 2 \frac{z}{T} \right) \right]$$

The wave pressure p_2 , in kN/m^2 , above the waterline is given by:

$$p_2 = p_{2wl} - 5,0 (z - T)$$

where:

- p_{1wl} : Wave sea pressure p_1 at the waterline
- p_{2wl} : Wave sea pressure p_2 at the waterline
- L : Rule length, in m, as given in Pt B, Ch 1, Sec 2, [3.1]
- B : Greatest moulded breadth, in m, as given in Pt B, Ch 1, Sec 2, [3.4]
- C_b : Block coefficient, as given in Pt B, Ch 1, Sec 2, [2.1]
- T : Maximum design draught, in m, as given in Pt B, Ch 1, Sec 2, [3.7]
- C : Coefficient given as follows:
 - for $90 \text{ m} \leq L \leq 300 \text{ m}$

$$C = 10,75 - \left(\frac{300 - L}{100} \right)^{1,5}$$
 - for $L > 300 \text{ m}$

$$C = 10,75$$
- C_r : Coefficient given by:

$$C_r = \left(1,25 - \left(0,025 \frac{2k_r}{\sqrt{GM}} \right) \right) k$$
- k : Coefficient given by:
 - for ships without bilge keel

$$k = 1,2$$
 - for ships with bilge keel

$$k = 1,0$$

k_r : Roll radius of gyration. If the actual value is not available, k_r is taken equal to:

- for ships with even distribution of mass in transverse section (e.g. alternate heavy cargo loading or homogeneous light cargo loading):

$$k_r = 0,39 B$$

- for ships with uneven distribution of mass in transverse section (e.g. homogeneous heavy cargo distribution):

$$k_r = 0,25 B$$

GM : If the actual value of GM is not available: $GM = 0,12 B$

z : Vertical distance, in m, from the baseline to the load point

k_s : Coefficient given as follows:

- at aft end of L:

$$k_s = C_b + \frac{0,83}{\sqrt{C_b}}$$

- between $0,2 L$ and $0,6 L$ from aft end of L:

$$k_s = C_b$$

- at forward end of L:

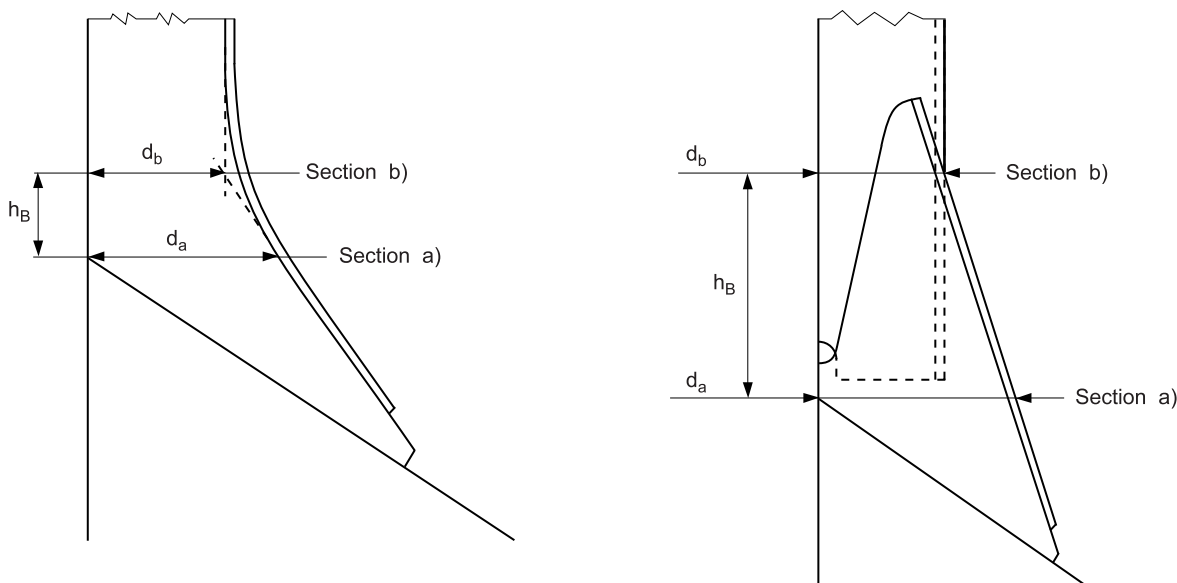
$$k_s = C_b + \frac{1,33}{C_b}$$

Between the above specified points, k_s is to be interpolated linearly

k_f : Coefficient given as follows:

$$k_f = 0,8 C$$

Figure 18 : Sections a) and b)



5.5.3 Allowable stresses

The allowable normal and shear stresses σ_a and τ_a , in N/mm², in the side shell frames and brackets are given by:

$$\sigma_a = 0,90 R_{eH}$$

$$\tau_a = 0,40 R_{eH}$$

where R_{eH} is the minimum yield stress, in N/mm², of the material.

5.5.4 Shear strength check

Where t_M in the lower part of side frames, as defined in Fig 15, is equal to or less than t_{COAT} , shear strength check is to be carried out in accordance with the following.

The thickness $t_{REN,S}$, in mm, is the greater of the thicknesses $t_{REN,Sa}$ and $t_{REN,Sb}$ obtained from the shear strength check at sections a) and b) (see Fig 18 and [5.5.2]) given by the following, but need not be taken greater than $0,75 t_{S12}$.

- At section a)

$$t_{REN,Sa} = \frac{1000 k_s P_{fr,a}}{d_a \sin \phi \tau_a}$$

- At section b)

$$t_{REN,Sb} = \frac{1000 k_s P_{fr,b}}{d_b \sin \phi \tau_a}$$

where:

k_s : Shear force distribution factor, to be taken equal to 0,6

$P_{fr,a}, P_{fr,b}$: Pressure forces defined in [5.5.2], item a)

d_a : Bracket web depth, in mm, at section a) (see Fig 18)

d_b : Frame web depth, in mm, at section b) (see Fig 18). In case of separate brackets, d_b is to be taken as the minimum web depth deducing possible scallops

Φ : Angle between frame web and shell plate

τ_a : Allowable shear stress, in N/mm², defined in [5.5.3].

5.5.5 Bending strength check

Where the lower bracket length or depth does not meet the requirements in Pt D, Ch 4, Sec 3, [2.2.6], the actual section modulus, in cm³, of the brackets and side frames at section a) and b) is to be not less than:

- At section a)

$$Z_a = \frac{1000 P_{fr,a} h}{m_a \sigma_a}$$

- At section b)

$$Z_b = \frac{1000 P_{fr,a} h}{m_b \sigma_a}$$

where:

$P_{fr,a}$: Pressure force defined in [5.5.2], item a)

h : Side frame span, in m, as defined in Fig 15

σ_a : Allowable normal stress, in N/mm², as defined in [5.5.3]

m_a, m_b : Bending moment coefficients, as defined in Tab 3.

The actual section modulus of the brackets and side frames is to be calculated about an axis parallel to the attached plate, based on the measured thicknesses. For precalculations, alternative thickness values may be used, provided they are not less than:

- t_{REN} for the web thickness
- the minimum thicknesses allowed by the Society renewal criteria for flange and attached plating.

The attached plate breadth is equal to the frame spacing, measured along the shell at midspan of h .

If the actual section moduli at sections a) and b) are less than the values Z_a and Z_b , the frames and brackets are to be renewed or reinforced in order to obtain actual section moduli not less than $1,2 Z_a$ and $1,2 Z_b$, respectively.

In such a case, renewal or reinforcements of the flange are to be extended over the lower part of side frames, as defined in Fig 15.

Table 3 : Bending moment coefficients m_a and m_b

	m_a	m_b		
		$h_B \leq 0,08 h$	$h_B = 0,10 h$	$h_B \geq 0,125 h$
Empty holds of ships approved to operate in non homogeneous loading conditions	10	17	19	22
Other cases	12	20	22	26

Note 1: Non homogeneous loading condition means a loading condition in which the ratio between the highest and the lowest filling ratio, evaluated for each hold, exceeds 1,20 corrected for different cargo densities.
 Note 2: For intermediate values of the bracket length h_B , the coefficient m_b is obtained by linear interpolation between the Table values.

6 Cargo hatch cover securing arrangements for bulk carriers not built in accordance with Pt B, Ch 9, Sec 7

6.1 Application

6.1.1 These retroactive rule requirements apply to ships which are assigned one of the following service notations:

- bulk carrier ESP
- bulk carrier BC-A ESP
- bulk carrier BC-B ESP
- bulk carrier BC-C ESP,

which were not built in accordance with Pt B, Ch 9, Sec 7, [1] to Pt B, Ch 9, Sec 7, [7] of edition February 2003 of the Rules as amended in accordance with November 2003 amendments or subsequent editions.

6.1.2 They are related to steel hatch cover securing devices and stoppers for cargo hold hatchways No.1 and No.2 which are wholly or partially within 0,25 L of the fore perpendicular, except pontoon type hatch cover.

6.2 Securing devices

6.2.1 The strength of securing devices is to comply with the following items:

- a) Panel hatch covers are to be secured by appropriate devices (bolts, wedges or similar) suitably spaced alongside the coamings and between cover elements.

Arrangement and spacing are to be determined with due attention to the effectiveness for weather-tightness, depending upon the type and the size of the hatch cover, as well as on the stiffness of the cover edges between the securing devices.

- b) The net cross area of each securing device is to be not less than the value obtained, in cm^2 , from the following formula:

$$A = 1,4 S_s \left(\frac{235}{R_{eH}} \right)^f$$

where:

S_s : Spacing, in m, of securing devices, to be taken not less than 2 m

R_{eH} : Minimum yield stress, in N/mm^2 , of the steel used for fabrication, defined in Pt B, Ch 4, Sec 1, [2] not to be taken greater than 70% of the minimum ultimate tensile strength R_m defined in Pt B, Ch 4, Sec 1, [2]

f : Coefficient taken equal to:

- 0,75 for $R_{eH} > 235 \text{ N/mm}^2$
- 1,00 for $R_{eH} \leq 235 \text{ N/mm}^2$

Rods or bolts are to have a net diameter not less than 19 mm for hatchways exceeding 5 m^2 in area.

- c) Between cover and coaming and at cross-joints, a packing line pressure sufficient to obtain weathertightness is to be maintained by the securing devices.

For packing line pressures exceeding 5 N/mm, the net cross area A is to be increased in direct proportion. The packing line pressure is to be specified.

- d) The hatch cover edge stiffness is to be sufficient to maintain adequate sealing pressure between securing devices.

The moment of inertia I of edge elements is to be not less than the value obtained, in cm^4 , from the following formula:

$$I = 6 p_L S_s^4$$

where:

p_L : Packing line pressure, in N/mm, to be taken not less than 5 N/mm

S_s : Spacing, in m, of securing devices.

- e) Securing devices are to be of reliable construction and securely attached to the hatchway coamings, decks or covers. Individual securing devices on each cover are to have approximately the same stiffness characteristics.

- f) Where rod cleats are fitted, resilient washers or cushions are to be incorporated.

- g) Where hydraulic cleating is adopted, a positive means is to be provided to ensure that it remains mechanically locked in the closed position in the event of failure of the hydraulic system.

6.3 Stoppers

6.3.1 No.1 and No.2 hatch covers are to be effectively secured, by means of stoppers, against the transverse forces arising from a pressure of 175 kN/m^2 .

6.3.2 No.2 hatch covers are to be effectively secured, by means of stoppers, against the longitudinal forces acting on the forward end arising from a pressure of 175 kN/m^2 .

6.3.3 No.1 hatch cover is to be effectively secured, by means of stoppers, against the longitudinal forces acting on the forward end arising from a pressure of 230 kN/m^2 .

This pressure may be reduced to 175 kN/m^2 if a fore-castle is fitted.

6.3.4 The equivalent stress, in stoppers and their supporting structures and calculated in the throat of the stopper welds is not to exceed the allowable value of 0,8 R_{eH} .

6.4 Materials and welding

6.4.1 Where stoppers or securing devices are fitted to comply with the requirements of this article, they are to be manufactured of materials, including welding electrodes complying with NR216 Materials and Welding.

7 Guidance on loading/unloading sequences

7.1

7.1.1 The minimum acceptable number of typical sequences is:

- one homogeneous full load condition
- one part load condition where relevant, such as block loading or two port unloading
- one full load alternate hold condition, if the ship is approved for alternate hold loading.

7.1.2 The shipowner/operator should select actual loading/unloading sequences, where possible, which may be port specific or typical.

7.1.3 The sequence may be prepared using the onboard loading instrument. The selected loading conditions should be built up step by step from commencement of cargo loading to reaching full deadweight capacity. Each time the loading equipment changes position to a new hold defines a step. Each step is to be documented and submitted to the Society. The printout from the loading instrument is generally acceptable. This allows the actual bending moments and shear forces to be verified and prevent the permissible values being exceeded. In addition, the local strength of each hold may need to be considered during the loading.

7.1.4 For each loading condition a summary of all steps is to be included. This summary is to highlight the essential information for each step such as:

- how much cargo is filled in each hold during the different steps
- how much ballast is discharged from each ballast tank during the different steps
- the maximum still water bending moment and shear at the end of each step
- the ship's trim and draught at the end of each step.

7.1.5 The approved typical loading/unloading sequences may be included in the approved loading manual or take the form of an addendum. A copy of the approved typical loading/unloading sequences is to be placed onboard the ship.

8 Water level detectors on single hold cargo ships other than bulk carriers

8.1 Application

8.1.1 These retroactive rule requirements apply to ships indicated in Ch 6, Sec 4, [2.1.1].

8.2 Water level detectors

8.2.1 The water level detectors are to:

- give an audible and visual alarm at the navigation bridge when the water level above the inner bottom in the cargo hold reaches a height of not less than 0,3 m, and another when such level reaches not more than 15% of the mean depth of the cargo hold; and
- be fitted at the aft end of the hold, or above its lowest part where the inner bottom is not parallel to the designed waterline. Where webs or partial watertight bulkheads are fitted above the inner bottom, the Society may require the fitting of additional detectors.

8.2.2 For ships not provided with double bottom in cargo hold, the water level detectors are to:

- give an audible and visual alarm at the navigation bridge when the water level above the bottom in the cargo hold reaches a height of not less than 0,3 m or the height of the floors at centerline, whichever is the highest, and another when such level reaches not more than 15% of the mean depth of the cargo hold; and
- be fitted at the aft end of the hold, or above its lowest part where the bottom is not parallel to the designed waterline. Where webs or partial watertight bulkheads are fitted above the bottom, the Society may require the fitting of additional detectors.



**BUREAU
VERITAS**

Shaping a World of Trust

Marine & Offshore
Le Triangle de l'Arche - 8 Cours du Triangle - CS 50101
92937 Paris La Defense Cedex - France
Tel: + 33 (0)1 55 24 70 00
<https://marine-offshore.bureauveritas.com/bv-rules>
© 2021 Bureau Veritas – All rights reserved