

RULES FOR THE CLASSIFICATION OF STEEL SHIPS

NR467 - JULY 2023

PART D
SERVICE NOTATIONS



STEEL SHIPS



BUREAU
VERITAS

BUREAU VERITAS RULES FOR THE CLASSIFICATION OF STEEL SHIPS

NR467 - JULY 2023

This version of the document takes precedence over previous revision. Unless otherwise specified, these rules apply to ships for which contracts are signed on or after July 1st, 2023. The Society may refer to the contents hereof before July 1st, 2023, as and when deemed necessary or appropriate.

The PDF electronic version of this document available at the Bureau Veritas Marine & Offshore website <https://marine-offshore.bureauveritas.com/> is the official version and shall prevail if there are any inconsistencies between the PDF version and any other available version.

These rules are provided within the scope of the Bureau Veritas Marine & Offshore General Conditions, enclosed at the end of Part A of NR467, Rules for the Classification of Steel Ships. The current version of these General Conditions is available at the Bureau Veritas Marine & Offshore website.

PART A

CLASSIFICATION AND
SURVEYS

NR467 A DT R20 JULY 2023

PART B

HULL AND STABILITY

NR467 B DT R15 JULY 2023

PART C

MACHINERY, ELECTRICITY,
AUTOMATION AND FIRE
PROTECTION

NR467 C DT R15 JULY 2023

PART D

SERVICE NOTATIONS

NR467 D DT R15 JULY 2023

PART E

SERVICE NOTATIONS FOR
OFFSHORE SERVICE
VESSELS AND TUGS

NR467 E DT R06 JULY 2023

PART F

ADDITIONAL CLASS
NOTATIONS

NR467 F DT R15 JULY 2023

BUREAU VERITAS MARINE & OFFSHORE

1 place Zaha Hadid
CS 40381
92062 Paris La Défense Cedex - France
+33 (0)1 55 24 70 00

marine-offshore.bureauveritas.com/rules-guidelines

© 2023 BUREAU VERITAS - All rights reserved



**BUREAU
VERITAS**



NR467

RULES FOR THE CLASSIFICATION OF STEEL SHIPS

Part D Service Notations

Chapter 1	Ro-Ro Cargo Ships and Pure Car and/or Truck Carriers
Chapter 2	Container Ships
Chapter 3	Livestock Carriers
Chapter 4	Bulk Carriers
Chapter 5	Ore Carriers
Chapter 6	Combination Carriers
Chapter 7	Oil Tankers and FLS Tankers
Chapter 8	Chemical Tankers
Chapter 9	Liquefied Gas Carriers
Chapter 10	Tankers
Chapter 11	Passenger Ships
Chapter 12	Ro-Ro Passenger Ships
Chapter 13	Ships for Dredging Activity
Chapter 14	Non-Propelled Units
Chapter 15	Fishing Vessels
Chapter 16	Offshore Patrol Vessels

Table of Content

Chapter 1	Ro-Ro Cargo Ships and Pure Car and/or Truck Carriers	
Section 1	General	
1	Application	40
	1.1	
Section 2	Hull and Stability	
1	General	41
	1.1 Application	
	1.2 Documents to be submitted	
2	Stability	41
	2.1 Damage stability requirements for ship where additional class notation SDS is required	
3	Structure design principles	41
	3.1 Wood sheathing	
4	Design loads	41
	4.1 Load combinations for direct strength analysis	
5	Global strength	41
	5.1 Hull girder strength	
	5.2 Global transverse strength	
6	Construction and testing	42
	6.1 Special structural details	
Section 3	Machinery and Systems	
1	Scuppers and sanitary discharges	43
	1.1 Drainage of ro-ro cargo spaces, intended for the carriage of motor vehicles with fuel in their tanks for their own propulsion	
Section 4	Electrical Installations	
1	General	44
	1.1 Applicable requirements	
	1.2 Documentation to be submitted	
	1.3 Safety characteristics	
2	Installation	45
	2.1 Installations in closed ro-ro cargo spaces	
	2.2 Installations in cargo spaces other than ro-ro cargo spaces but intended for the carriage of motor vehicles	
3	Type approved components	45
	3.1	

Chapter 2 Container Ships

Section 1	General	
1	General	47
	1.1 Application	
	1.2 Definition	

Table of Content

Section 2	Hull and Stability	
1	General	48
	1.1 Application	
	1.2 Documents and information	
2	Stability	48
	2.1 Intact stability	
	2.2 Damage stability requirements for ships where the additional class notation SDS is required	
3	Structure design principles	49
	3.1 Ship structure	
	3.2 Material	
	3.3 Net scantling approach	
	3.4 Strength principles	
	3.5 Bottom structure	
	3.6 Deck structure	
	3.7 Bulkheads	
4	Design loads	53
	4.1 Still water hull girder loads	
	4.2 Dynamic hull girder loads	
5	Load combinations for direct strength analysis based on partial three-dimensional model	56
	5.1 General	
	5.2 Container weight	
	5.3 Loading conditions for cargo holds strength check	
	5.4 Loading conditions for fuel oil tanks	
	5.5 Load cases	
6	Load combinations for direct strength analysis based on full length model	61
	6.1 Loading condition	
	6.2 Load cases	
7	Hull girder strength assessment	62
	7.1 Section modulus and moment of inertia	
8	Cargo hold structural strength analysis	62
	8.1 General	
9	Local structural strength analysis	62
	9.1 Screening criteria	
10	Buckling	62
	10.1 Load cases	
11	Fatigue	64
	11.1 Corrosion model	
	11.2 Design loading condition for fatigue assessment	
12	Fixed cell guides	64
	12.1 General	
	12.2 Arrangement of fixed cell guides	
	12.3 Strength criteria	
13	Lashing bridge	65
	13.1 General	
	13.2 Design load	
	13.3 Strength assessment	
14	Lashing items	67
	14.1 Fixed cargo securing devices	
	14.2 Lashing software	

Table of Content

Section 3	Machinery and Systems	
1	Open-top container ships	68
	1.1	

Chapter 3 Livestock Carriers

Section 1	General	
1	General	70
	1.1 Application	
	1.2 Summary table	

Section 2	Hull and Stability	
1	General	71
	1.1 Documents to be submitted	
2	General arrangement	71
	2.1 Livestock arrangement	
	2.2 Arrangement of spaces dedicated to the carriage of livestock	
	2.3 Means of escape and access	
3	Stability	72
	3.1 Intact stability	
4	Design loads	72
	4.1 Local loads	
	4.2 Load combinations for direct strength analysis	
5	Hull girder strength	72
	5.1 Application	
	5.2 Global transverse strength	
6	Hull scantlings	73
	6.1 Scantlings of plating, ordinary stiffeners and primary supporting members	

Section 3	Systems serving Livestock Spaces	
1	General	74
	1.1 Application	
	1.2 Documents to be submitted	
2	Design of the systems	74
	2.1 General	
	2.2 Ventilation system	
	2.3 Fodder and fresh water systems	
	2.4 Washing system	
	2.5 Drainage system	
	2.6 Lighting system	

Section 4	Fire-Fighting Systems in Livestock Spaces	
1	General	76
	1.1 Application	
	1.2 Documents to be submitted	
2	Fire-fighting appliances	76
	2.1 Fire hoses	
	2.2 Additional fire-fighting means	

Table of Content

Chapter 4 Bulk Carriers

Section 1	General	
1	General	78
	1.1 Application	
Section 2	Ship Arrangement	
1	General arrangement design	79
	1.1 General	
2	Access arrangement	79
	2.1 Access arrangement to double bottom and pipe tunnel	
	2.2 Access arrangement to and within spaces in, and forward of, the cargo area	
Section 3	Hull and Stability	
1	Stability	81
	1.1 Definitions	
	1.2 Intact stability	
	1.3 Damage stability requirements for ships where additional class notation SDS is required	
2	Structure design principles	83
	2.1 Double bottom structure	
	2.2 Single side structure	
	2.3 Double side structure	
	2.4 Deck structure	
3	Design loads	86
	3.1 Loading conditions for longitudinal strength assessment	
	3.2 Hull girder loads in flooded conditions	
	3.3 Load combinations for direct strength analysis	
4	Hull girder strength	87
	4.1 Hull girder yield strength in flooded conditions	
5	Hull scantlings of bulk carriers	88
	5.1 Plating	
	5.2 Ordinary stiffeners	
	5.3 Buckling check in flooded conditions	
6	Protection of hull metallic structures	89
	6.1 Protection of cargo holds	
7	Construction and testing	91
	7.1 Welding and weld connections	
	7.2 Special structural details	
Appendix 1	Intact Stability Criteria for Grain Loading	
1	Calculation of assumed heeling moments due to cargo shifting	92
	1.1 Stowage of bulk grain	
	1.2 General assumptions	
	1.3 Assumed volumetric heeling moment of a filled compartment trimmed	
	1.4 Assumed volumetric heeling moment of a filled compartment untrimmed	
	1.5 Assumed volumetric heeling moments in trunks	
	1.6 Assumed volumetric heeling moment of a partly filled compartment	
	1.7 Other assumptions	
	1.8 Saucers	
	1.9 Overstowing arrangements and securing	

Table of Content

	2	Dispensation from trimming ends of holds in certain ships	99
	2.1	Calculation example	
Appendix 2		Hold Mass Curves	
	1	General	105
	1.1	Application	
	2	Hold mass curves	106
	2.1	General	
<hr/>			
Chapter 5		Ore Carriers	
Section 1		General	
	1	General	115
	1.1	Application	
Section 2		Ship Arrangement	
	1	General	116
	1.1	Application	
	2	General arrangement design	116
	2.1	General	
	3	Access arrangement	117
	3.1	Access arrangement to double bottom and pipe tunnel	
	3.2	Access arrangement to and within spaces in, and forward of, the cargo area	
Section 3		Hull and Stability	
	1	General	118
	1.1	Loading manual and loading instruments	
	2	Stability	118
	2.1	Intact stability	
	2.2	Damage stability requirements for ships where additional class notation SDS has been required	
	3	Structure design principles	118
	3.1	Double bottom structure	
	3.2	Side structure	
	3.3	Deck structure	
	3.4	Longitudinal bulkhead structure	
	3.5	Transverse bulkhead structure	
	4	Design loads	119
	4.1	Hull girder loads	
	4.2	Load combinations for direct strength analysis	
	5	Hull scantlings	120
	5.1	Corrosion addition	
	5.2	Additional requirements	
	6	Construction and testing	120
	6.1	Welding and weld connections	
	6.2	Special structural details	

Chapter 6 Combination Carriers

Section 1	General	
1	General	122
	1.1 Application	
Section 2	Ship Arrangement	
1	General arrangement design	123
	1.1 General	
	1.2 Double bottom tanks or compartments	
	1.3 Navigation position	
2	Size and arrangement of cargo tanks and slop tanks	126
	2.1 Cargo tanks	
	2.2 Oil outflow	
	2.3 Slop tanks	
3	Size and arrangement of protective ballast tanks or compartments	128
	3.1 General	
	3.2 Size and arrangement of ballast tanks or compartments	
4	Size and arrangement of segregated ballast tanks (SBT)	129
	4.1 General	
	4.2 Capacity of SBT	
5	Access arrangement	129
	5.1 Access to double bottom and pipe tunnel	
	5.2 Access arrangement to and within spaces in, and forward of, the cargo area	
	5.3 Access to dry cargo holds	
	5.4 Access to compartments in the oil cargo area	
	5.5 Access to the bow	
Section 3	Hull and Stability	
1	General	132
	1.1 Loading manual and loading instrument	
2	Stability	132
	2.1 Intact stability	
	2.2 Damage stability - dry cargoes or ballast loading conditions - for ships where additional class notation SDS is requested	
	2.3 Damage stability - oil cargoes - for ships where additional class notation SDS is requested	
3	Structure design principles of ships with the service notation combination carrier /OBO ESP	135
	3.1 Double bottom structure	
	3.2 Double side structure	
	3.3 Deck structure	
4	Structure design principles of ships with the service notation combination carrier /OOC ESP	136
	4.1 Double bottom structure	
	4.2 Side structure	
	4.3 Deck structure	
	4.4 Longitudinal bulkhead structure	
	4.5 Transverse bulkhead structure	
5	Design loads	137
	5.1 Loading conditions for longitudinal strength assessment	
	5.2 Load combinations for direct strength analysis	
	5.3 Local loads	

Table of Content

	6	Hull scantlings	137
	6.1	Strength check with respect to stresses due to the temperature gradient	
	7	Other structures	138
	7.1	Machinery space	
	7.2	Opening arrangement	
	8	Hull outfitting	138
	8.1	Equipment	
	9	Protection of hull metallic structures	138
	9.1	Protection by aluminium coatings	
	10	Cathodic protection of tanks	138
	10.1	General	
	10.2	Anodes	
	10.3	Impressed current systems	
	11	Construction and testing	139
	11.1	Welding and weld connections	
	11.2	Special structural details	
Section 4	Machinery and Cargo Systems		
	1	General	140
	1.1	Application	
	1.2	Documents	
	2	General requirements	140
	2.1	Ventilation and gas detection	
	2.2	Arrangement of cargo lines	
	2.3	Cargo openings	
	2.4	Cofferdam filling and draining	
	3	Slop tanks	141
	3.1	Segregation of piping systems	
	3.2	Venting system	
	3.3	Discharge pumping and piping arrangement	

Chapter 7 Oil Tankers and FLS Tankers

Section 1	General		
	1	General	143
	1.1	Application	
	1.2	Definitions	
Section 2	Ship Arrangement		
	1	General	146
	1.1	Application	
	1.2	Documents to be submitted	
	2	General arrangement of the ship with regard to fire prevention and crew safety	146
	2.1	Location and separation of spaces	
	2.2	Access and openings	
	2.3	Ventilation	

Table of Content

	3	General arrangement of the ship with regard to pollution prevention	151
	3.1	Application	
	3.2	Protection of the cargo tank length in the event of grounding or collision	
	3.3	Segregation of oil and water ballast	
	3.4	Accidental oil outflow performance	
	3.5	Cleaning of cargo tanks	
	3.6	Retention of oil on board - Slop tanks	
	3.7	Deck spills	
	3.8	Pump-room bottom protection	
	4	Structural arrangement of asphalt carrier independent tanks and supports	156
	4.1	Supports	
	4.2	Inspectability of the cargo area	
Section 3		Hull and Stability	
	1	General	159
	1.1	Documents to be submitted	
	2	Stability	159
	2.1	Application	
	2.2	Intact stability	
	2.3	Damage stability for ships where the additional class notation SDS is required	
	3	Structure design principles	162
	3.1	Framing arrangement	
	3.2	Bulkhead structural arrangement	
	4	Design loads	162
	4.1	Loading conditions for longitudinal strength assessment	
	4.2	Local loads	
	4.3	Load combinations for direct strength analysis	
	5	Hull scantlings	163
	5.1	Strength check with respect to stresses due to the temperature gradient	
	5.2	Hull girder stress for independent tanks structures	
	6	Scantlings of independent tanks structures	164
	6.1	Plating	
	6.2	Ordinary stiffeners	
	6.3	Primary supporting members	
	7	Supports of independent tanks	164
	7.1	General	
	7.2	Vertical supports	
	7.3	Antirolling keys	
	7.4	Antipitching keys	
	7.5	Anticollision keys	
	7.6	Antiflotation keys	
	7.7	Yielding criteria	
	8	Independent tanks direct strength analysis	166
	8.1	General	
	8.2	Three cargo holds model	
	8.3	Local fine mesh models	
	9	Other structures	167
	9.1	Machinery space	
	9.2	Opening arrangement	
	10	Hull outfitting	167
	10.1	Equipment	

Table of Content

11	Protection of hull metallic structures	167
	11.1 Protection by aluminium coatings	
	11.2 Material and coatings of tanks	
12	Cathodic protection of tanks	168
	12.1 General	
	12.2 Anodes	
	12.3 Impressed current systems	
13	Construction and testing	168
	13.1 Welding and weld connections	
	13.2 Special structural details	

Section 4 Machinery and Cargo Systems

1	General	170
	1.1 Application	
	1.2 Documents to be submitted	
	1.3 Abbreviations	
2	Piping systems other than cargo piping system	172
	2.1 General	
	2.2 Bilge system	
	2.3 Ballast system	
	2.4 Air and sounding pipes of spaces other than cargo tanks	
	2.5 Scupper pipes	
	2.6 Heating systems intended for cargo	
3	Cargo pumping and piping systems	176
	3.1 General	
	3.2 Cargo pumping system	
	3.3 Cargo piping design	
	3.4 Cargo piping arrangement and installation	
	3.5 Arrangement of cargo pump rooms	
	3.6 Design of integrated cargo and ballast systems on tankers	
4	Cargo tanks and fittings	181
	4.1 Application	
	4.2 Cargo tank venting	
	4.3 Cargo tank inerting, purging and/or gas-freeing	
	4.4 Cargo tank level gauging systems	
	4.5 Protection against tank overfilling	
	4.6 Tank washing systems	
5	Prevention of pollution by cargo oil	186
	5.1 General	
	5.2 Discharge into the sea of cargo oil or oily mixtures	
	5.3 Oil discharge monitoring and control system	
	5.4 Pumping, piping and discharge arrangements	
6	Certification, inspection and testing	187
	6.1 Application	
	6.2 Workshop tests	
	6.3 Shipboard tests	
7	Steering gear	189
	7.1 General	
	7.2 Design of the steering gear	
	7.3 Alternative design for ships of less than 100 000 tonnes deadweight	
8	Additional requirements for ships having the additional service feature asphalt carrier	192
	8.1 Application	
	8.2 Additional requirements	

Table of Content

	9	Specific requirements for ships having the notations “FLS tanker” or “FLS tanker, flash point > 60°C”	192
	9.1	Application	
	9.2	Design requirements	
Section 5	Electrical Installations		
	1	General	194
	1.1	Application	
	1.2	Documentation to be submitted	
	1.3	System of supply	
	1.4	Earth detection	
	1.5	Mechanical ventilation of hazardous spaces	
	1.6	Electrical installation precautions	
	2	Hazardous locations and types of equipment	195
	2.1	Special requirements for oil tankers carrying flammable liquids having a flash point not exceeding 60°C and for oil tankers carrying flammable liquids having a flash point exceeding 60°C heated to a temperature within 15°C of their flash point or above their flash point	
	2.2	Special requirements for oil tankers carrying flammable liquids having a flash point exceeding 60°C unheated or heated to a temperature below and not within 15°C of their flash point	
	2.3	Special requirements for FLS tankers	
Section 6	Fire Protection		
	1	General	197
	1.1	Application	
	1.2	Documents to be submitted	
	2	General requirements	197
	2.1	Sources of ignition	
	2.2	Electrical equipment	
	3	Fixed deck foam system	198
	3.1	Application	
	3.2	System design	
	3.3	Arrangement and installation	
	4	Fire-extinguishing systems except deck foam system	199
	4.1	Pressure water fire-extinguishing systems	
	4.2	Fire-extinguishing systems for cargo pump rooms	
	5	Inert gas systems	200
	5.1	Application	
	5.2	General requirements	
	5.3	Additional requirements for nitrogen generator systems	
	5.4	Nitrogen/inert gas systems fitted for purposes other than inerting required by [5.1.1]	
	6	Fixed hydrocarbon gas detection systems	202
	6.1	Engineering specifications	
	7	Gas measurement and detection	203
	7.1	Provisions applicable to all ships	
	7.2	Additional provisions for ships having the service notation oil tanker or FLS tanker	
	7.3	Additional provisions for ships fitted with an inert gas system	
	7.4	Provisions for installation of gas analysing units	
Appendix 1	Devices to Prevent the Passage of Flame into the Cargo Tanks		
	1	General	205
	1.1	Application	
	1.2	Definitions	
	1.3	Instruction manual	

Table of Content

	2 Design of the devices	206
	2.1 Principles	
	2.2 Mechanical design	
	2.3 Performance	
	2.4 Flame screens	
	2.5 Marking of devices	
	3 Sizing, location and installation of devices	208
	3.1 Sizing of devices	
	3.2 Location and installation of devices	
	4 Type test procedures	208
	4.1 Principles	
	4.2 Test procedure for flame arresters located at openings to the atmosphere	
	4.3 Test procedures for high velocity vents	
	4.4 Test rig and test procedures for detonation flame arresters located in-line	
	4.5 Operational test procedure	
	4.6 Laboratory report	
Appendix 2	Design of Crude Oil Washing Systems	
	1 General	213
	1.1 Application	
	1.2 Definitions	
	1.3 Operations and Equipment Manual	
	2 Design and installation	213
	2.1 Piping	
	2.2 Tank washing machines	
	2.3 Pumps	
	2.4 Stripping system	
	2.5 Ballast lines	
	3 Inspection and testing	216
	3.1 Initial survey	
	3.2 Piping	
	3.3 Tank washing machines	
	3.4 Stripping system	
Appendix 3	Lists of Oils	
	1 Application	217
	1.1 Scope of the lists of oils	
	2 Lists of products	217
	2.1 List of oils	
Appendix 4	List of Products for which Part D, Chapter 8 and IBC Code do not Apply	
	1 Application	218
	1.1 Scope of the list	
	1.2 Safety and pollution hazards	
	2 List of products for which Part D, Chapter 8 and IBC Code do not apply	218
	2.1	
Appendix 5	Accidental Oil Outflow Performance	
	1 General	220
	1.1 Purpose	
	1.2 Application	
	2 Accidental oil outflow performance	220
	2.1 Mean oil outflow parameter	
	2.2 Calculation	

Table of Content

3	Piping arrangements	224
3.1	Provision regarding piping arrangements	

Chapter 8 Chemical Tankers

Section 1 General

1	General	226
1.1	Application	
1.2	IBC Code requirements and the Society's rules	
2	Additional requirements	227
2.1	Emergency towing arrangement	
2.2	Steering gear	
3	Documentation to be submitted	227
3.1		

Section 2 Ship Survival Capability and Location of Cargo Tanks

1	Freeboard and intact stability	229
1.1	Intact stability	
2	Conditions of loading	229
2.1	Additional loading conditions for ships where additional class notation SDS is requested	
3	Location of cargo tanks	229
3.1	Minimum distance of cargo tanks from shell	
3.2	Suction wells	
4	Flooding assumptions for ships where additional class notation SDS is requested	229
4.1	Tunnels, ducts and pipes in the damaged zone	
5	Standard of damage for ships where additional class notation SDS is requested	230
5.1	Damage to stepped machinery space forward bulkhead	
5.2	Longitudinal extension of damage to superstructure	
6	Survival requirements for ships where additional class notation SDS is requested	230
6.1	General	
6.2	Intermediate stages of flooding	
6.3	Definition of range of positive stability	
6.4	Survival criterion	
6.5	Type 3 ships less than 125 m in length	

Section 3 Ship Arrangement

1	Cargo segregation	232
1.1	Segregation of cargoes mutually reacting	
1.2	Cargo piping arrangement	
2	Accommodation, service and machinery spaces and control stations	233
2.1	Location of paint lockers	
2.2	Air intakes and other openings to accommodation spaces	
2.3	Windows, sidescuttles and doors to accommodation spaces	
2.4	Access to the bow	
3	Cargo pump rooms	233
3.1	General requirement	
3.2	Machinery driven by shafting passing through pump room bulkheads	

Table of Content

	4	Access to spaces in the cargo area	234
	4.1	General	
	4.2	Horizontal openings	
	4.3	Vertical openings	
	5	Bilge and ballast arrangements	235
	5.1	Ballast segregation	
	5.2	Ballast filling arrangement	
	5.3	Bilge	
	6	Integrated cargo and ballast systems	236
	6.1		
	7	Bow or stern loading and unloading arrangements	236
	7.1	Coamings	
Section 4		Cargo Containment	
	1	General	237
	1.1	Application	
	2	Structure design principles	237
	2.1	Materials	
	2.2	Hull structure	
	2.3	Bulkhead structure	
	3	Hull girder loads	238
	3.1	Still water loads	
	3.2	Load combinations for direct strength analysis	
	4	Hull scantlings	238
	4.1	Plating	
	5	Scantlings of independent tank structures	239
	5.1	General	
	6	Supports of independent tanks	239
	6.1	General	
	7	Other structures	239
	7.1	Machinery space	
	8	Protection of hull metallic structures	239
	8.1	Aluminium coatings	
	8.2	Passivation treatment	
	9	Construction and testing	239
	9.1	Welding and weld connections	
	9.2	Structural details	
Section 5		Cargo Transfer	
	1	Piping scantlings	241
	1.1	General	
	1.2	Pipe classes	
	1.3	Pipe wall thickness calculation	
	2	Piping fabrication and joining details	242
	2.1	Pipes not required to be joined by welding	
	2.2	Expansion joints	
	2.3	Non-destructive testing of welded joints	
	3	Piping arrangements	242
	3.1	Arrangement of cargo piping	
	3.2	Removable piping systems	

Table of Content

	4	Cargo transfer control systems	243
	4.1	General	
	4.2	Control, monitoring and alarm devices and cargo control room	
	5	Ship's cargo hoses	243
	5.1	Compatibility	
	6	Bonding	243
	6.1	Static electricity	
	7	Certification, inspection and testing	244
	7.1	Application	
	7.2	Inspection and testing	
	7.3	Shipboard tests	
Section 6	Materials for Construction		
	1	General	246
	1.1	Material and coating characteristics	
	2	Special requirements for materials	246
	2.1	Miscellaneous requirements	
Section 7	Cargo Temperature Control		
	1	General	247
	1.1	Heated cargoes	
	1.2	Cargo heating and cooling systems	
	1.3	Valves and other fittings	
	1.4	Cargo temperature measuring system	
	1.5	Requirements for special products	
Section 8	Cargo Tank Venting and Gas-Freeing Arrangements		
	1	Cargo tank venting	249
	1.1	Venting system drainage	
	2	Types of tank venting system	249
	2.1	Controlled tank venting system	
	2.2	Position of vent outlets	
	3	Cargo tank gas-freeing	249
	3.1	Fans	
Section 9	Environmental Control		
	1	General	250
	1.1	Control by padding	
	1.2	Control by drying	
	1.3	Control by inerting	
	1.4	Control by ventilation	
	2	Inert gas systems	251
	2.1	General requirements	
	2.2	Additional requirements for nitrogen generator systems	
	2.3	Nitrogen /Inert gas systems fitted for purposes other than inerting required by [1.3.1]	

Table of Content

Section 10	Electrical Installations	
1	General	253
1.1	Application	
1.2	Documentation to be submitted	
1.3	System of supply	
1.4	Earth detection	
1.5	Mechanical ventilation of hazardous spaces	
1.6	Electrical installation precautions	
2	Hazardous locations and types of equipment	254
2.1	Electrical equipment permitted in hazardous areas for ships carrying dangerous chemicals in bulk having a flash-point not exceeding 60°C and ships carrying dangerous chemicals in bulk having a flash point exceeding 60°C heated to a temperature within 15°C of their flash point or above their flashpoint	
2.2	Electrical equipment permitted in hazardous areas for ships carrying dangerous chemicals in bulk having a flash-point exceeding 60°C unheated or heated to a temperature below and not within 15°C of their flashpoint	
2.3	Electrical equipment permitted in tankers carrying cargoes (for example acids) reacting with other products/materials to evolve flammable gases	
Section 11	Fire Protection and Fire Extinction	
1	General	257
1.1	Application	
2	Cargo pump rooms	257
2.1	Fixed fire-extinguishing systems	
3	Cargo area	257
3.1	Temperature of steam and heating media within the cargo area	
3.2	Monitors and foam applicators	
3.3	Simultaneous use of foam and water systems	
3.4	Portable fire-extinguishing equipment	
3.5	Ships carrying flammable products	
Section 12	Mechanical Ventilation in the Cargo Area	
1	Spaces normally entered during cargo handling operations	259
1.1	Miscellaneous requirements	
1.2	Additional requirements for non-sparking fans	
2	Pump rooms and other enclosed spaces normally entered	260
2.1	Clarification of general requirement	
3	Spaces not normally entered	261
3.1	Portable fans	
Section 13	Instrumentation	
1	Gauging	262
1.1	Types of gauging devices	
2	Vapour detection	262
2.1	Vapour detection instruments	
2.2	Provisions for installation of gas analysing units	
Section 14	Protection of Personnel	
1	Protective equipment	263
1.1	Location of protective equipment	
2	Safety equipment	263
2.1	Additional equipment for ships carrying toxic products	
2.2	Medical first aid equipment	

Table of Content

Section 15	Special Requirements	
1	Ammonium nitrate solution (93% or less)	264
1.1	Ammonia injection	
1.2	Cargo pumps	
2	Hydrogen peroxide solutions	264
2.1	Hydrogen peroxide solutions over 60% but not over 70%	
3	Propylene oxide and mixtures of ethylene oxide/propylene oxide with an ethylene oxide content of not more than 30% by weight	264
3.1	Tank cleaning	
3.2	Joints in cargo lines	
3.3	Oxygen content in tank vapour spaces	
3.4	Valves at cargo hose connections	
4	Acids	265
4.1	Electrical arrangements	
4.2	Leak detection system	
4.3	Lining for tanks and piping	
5	Toxic products	265
5.1	Return line to shore installation	
6	Cargoes protected by additives	265
6.1	Prevention of blockage by polymerisation	
7	Cargoes with a vapour pressure greater than 0,1013 MPa (1,013 bar) absolute at 37,8°C	266
7.1	General	
7.2	Return of expelled gases	
8	Special cargo pump room requirements	266
8.1	Clarification	
9	Overflow control	266
9.1	Independence of systems	
Section 16	Operational Requirements	
1	General	268
1.1		
Section 17	Summary of Minimum Requirements	
1	General	269
1.1		
Section 18	List of Chemicals to which this Chapter Does Not Apply	
1	General	270
1.1		
Section 19	Index of Products Carried In Bulk	
1	General	271
1.1		
Section 20	Transport of Liquid Chemical Wastes	
1	General	272
1.1		

Table of Content

Section 21	Criteria for Assigning Carriage Requirements for Products Subject to the IBC Code	
1	General	273
	1.1	

Chapter 9 Liquefied Gas Carriers

Section 1 General

1	General	275
	1.1 Application	
	1.2 IGC Code requirements and the Society's Rules	
2	Application and implementation	276
	2.1	
3	Additional requirements	277
	3.1 Emergency towing arrangement	
	3.2 Steering gear	
4	Definitions	277
	4.1	
5	Documentation to be submitted	280
	5.1	
6	Cargo equipment trials	282
	6.1 Scope	
	6.2 Extent of the tests	
7	Additional service features BOG-reliquefaction and LNG-subcooling	283
	7.1 General	
8	Additional service feature STL-SPM	283
	8.1 General	
	8.2 Documentation to be submitted	
	8.3 Structural design	
	8.4 Mechanical installation	
	8.5 Electrical and automation installation	

Section 2 Ship Survival Capability and Location of Cargo Tanks

1	General	286
	1.1	
2	Freeboard and stability	286
	2.1 General	
3	Damage assumptions	287
	3.1 General	
	3.2 Other damage	
4	Location of cargo tanks	288
	4.1 General	
5	Flood assumptions	293
	5.1 General	
6	Standard of damage	294
	6.1 General	

Table of Content

	7	Survival requirements	294
	7.1	General	
Section 3		Ship Arrangements	
	1	General	296
	1.1	Segregation of the cargo area	
	1.2	Accommodation, service and machinery spaces and control stations	
	1.3	Cargo machinery spaces and turret compartments	
	1.4	Cargo control rooms	
	1.5	Access to spaces in the cargo area	
	1.6	Airlocks	
	1.7	Bilge, ballast and oil fuel arrangements	
	1.8	Bow and stern loading and unloading arrangements	
	1.9	Emergency towing arrangements	
Section 4		Cargo Containment	
	1	General	305
	1.1	Scope	
	1.2	Definitions	
	1.3	Application	
	2	Cargo containment	306
	2.1	Functional requirement	
	2.2	Cargo containment safety principles	
	2.3	Secondary barriers in relation to tank types	
	2.4	Design of secondary barriers	
	2.5	Partial secondary barriers and primary barrier small leak protection system	
	2.6	Supporting arrangements	
	2.7	Associated structure and equipment	
	2.8	Thermal insulation	
	2.9	Use of cargo heater to raise the cargo temperature	
	3	Design loads	309
	3.1	General	
	3.2	Permanent loads	
	3.3	Functional loads	
	3.4	Environmental loads	
	3.5	Accidental loads	
	4	Structural integrity	311
	4.1	General	
	4.2	Structural analyses	
	4.3	Stress categories	
	4.4	Design conditions	
	4.5	Ultimate design condition	
	4.6	Fatigue design condition	
	4.7	Accident design condition	
	5	Materials	315
	5.1	General	
	5.2	Materials forming ship structure	
	5.3	Materials of primary and secondary barrier	
	5.4	Thermal insulation and other materials used in cargo containment systems	
	6	Construction processes	318
	6.1	General	
	6.2	Weld joint design	
	6.3	Design for gluing and other joining processes	
	6.4	Testing	

Table of Content

7	Supports	319
	7.1 Supporting arrangement	
	7.2 Calculation of reaction forces in way of tank supports	
	7.3 Checking criteria	
	7.4 Supports of type A and type B independent tanks	
	7.5 Supports of type C independent tanks	
8	Type A independent tanks	321
	8.1 Design basis	
	8.2 Structural analyses	
	8.3 Ultimate design condition	
	8.4 Accident design conditions	
	8.5 Testing	
9	Type B independent tanks	324
	9.1 Design basis	
	9.2 Structural analyses	
	9.3 Ultimate design condition	
	9.4 Fatigue design condition	
	9.5 Accident design condition	
	9.6 Testing	
	9.7 Marking	
10	Type C independent tanks	329
	10.1 Design basis	
	10.2 Shell thickness	
	10.3 Ultimate design condition	
	10.4 Fatigue design condition	
	10.5 Accident design condition	
	10.6 Testing	
	10.7 Marking	
11	Membrane tanks	332
	11.1 Design Basis	
12	Integral tanks	332
	12.1 Design basis	
	12.2 Structural analysis	
	12.3 Ultimate design condition	
	12.4 Accident design condition	
	12.5 Testing	
13	Semi-membrane tanks	333
	13.1 Design basis	
14	Cargo containment systems of novel configuration	333
	14.1 Limit state design for novel concepts	
 Section 5 Process Pressure Vessels and Liquid, Vapour and Pressure Piping Systems		
1	General	335
	1.1	
2	System requirements	335
	2.1	
	2.2 Arrangements: General	
3	Arrangements for cargo piping outside the cargo area	336
	3.1 Emergency cargo jettisoning	
	3.2 Bow and stern loading arrangements	
	3.3 Turret compartment transfer systems	
	3.4 Gas fuel piping systems	

Table of Content

4	Design pressure	336
	4.1	
5	Cargo system valve requirements	337
	5.1	
	5.2 Cargo manifold connections	
	5.3	
6	Cargo transfer arrangements	338
	6.1 General	
	6.2 Vapour return connections	
	6.3 Cargo tank vent piping systems	
	6.4 Cargo sampling connections	
	6.5 Cargo filters	
7	Installation requirements	339
	7.1 Design for expansion and contraction	
	7.2 Precautions against low temperature	
	7.3 Water curtain	
	7.4 Bonding	
8	Piping fabrication and joining details	340
	8.1 General	
	8.2 Direct connections	
	8.3 Flanged connections	
	8.4 Expansion joints	
	8.5 Other connections	
9	Welding, post-weld heat treatment and non-destructive testing	340
	9.1 General	
	9.2 Post-weld heat treatment	
	9.3 Non-destructive testing	
10	Installation requirements for cargo piping outside the cargo area	341
	10.1 Bow and stern loading arrangements	
	10.2 Turret compartment transfer systems	
	10.3 Gas fuel piping	
11	Piping system component requirements	341
	11.1 General	
	11.2 Piping scantlings	
	11.3 Allowable stress	
	11.4 High-pressure gas fuel outer pipes or ducting scantlings	
	11.5 Stress analysis	
	11.6 Flanges, valves and fittings	
	11.7 Ship's cargo hoses	
12	Materials	345
	12.1	
13	Testing requirements	345
	13.1 General	
	13.2 Type testing of Cargo pumps	
	13.3 Type testing of Valves	
	13.4 Type testing of expansion bellows	
	13.5 System testing requirements	
	13.6 Emergency shutdown valves	

Section 6 Materials of Construction and Quality Control

1	Definitions	348
	1.1	
2	Scope and general requirements	348
	2.1	

Table of Content

	3	General test requirements and specifications	348
	3.1	Tensile test	
	3.2	Toughness test	
	3.3	Bend test	
	3.4	Section observation and other testing	
	4	Requirements for metallic materials	350
	4.1	General requirements for metallic materials	
	5	Welding of metallic materials and non-destructive testing	355
	5.1	General	
	5.2	Welding consumables	
	5.3	Welding procedure tests for cargo tanks and process pressure vessels	
	5.4	Welding procedure tests for piping	
	5.5	Production weld tests	
	5.6	Non-destructive testing	
	6	Other requirements for construction in metallic materials	357
	6.1	General	
	6.2	Independent tank	
	6.3	Secondary barriers	
	6.4	Semi-membrane tanks	
	6.5	Membrane tanks	
	7	Non-metallic materials	358
	7.1	General	
Section 7		Cargo Pressure / Temperature Control	
	1	Methods of control	359
	1.1	General	
	2	Design of systems	359
	2.1	General	
	3	Reliquefaction of cargo vapours	359
	3.1		
	3.2	Refrigerating installation components	
	3.3	Refrigerants	
	4	Thermal oxidation of vapours	360
	4.1	General	
	4.2	Thermal oxidation systems	
	4.3	Burners	
	4.4	Safety	
	5	Pressure accumulation systems	361
	5.1	General	
	6	Liquid cargo cooling	361
	6.1	General	
	7	Segregation	361
	7.1	General	
	8	Availability	361
	8.1	General	
Section 8		Vent Systems for Cargo Containment	
	1	General	363
	1.1		
	2	Pressure relief systems	363
	2.1	General	

Table of Content

	3 Vacuum protection systems	366
	3.1 General	
	4 Sizing of pressure relieving system	366
	4.1 Sizing of pressure relief valves	
	4.2 Sizing of vent pipe system	
	4.3 Upstream pressure losses	
	4.4 Downstream pressure losses	
	4.5 Blow-down	
Section 9	Cargo Containment System Atmosphere Control	
	1 General	369
	1.1 Atmosphere control within the cargo containment system	
	1.2 Atmosphere control within the hold spaces (cargo containment systems other than type C independent tanks)	
	1.3 Environmental control of spaces surrounding type C independent tanks	
	1.4 Inerting	
	1.5 Inert gas production on board	
	1.6 Engineering specifications for nitrogen / inert gas systems	
Section 10	Electrical Installations	
	1 General	372
	1.1 Application	
	1.2 Documentation to be submitted	
	1.3 Definitions	
	1.4 General requirements	
	1.5 System of supply	
	1.6 Earth detection	
	1.7 Mechanical ventilation of hazardous spaces	
	2 Hazardous locations and types of equipment	375
	2.1 Electrical equipment permitted in gas-dangerous spaces and zones	
	2.2 Submerged cargo pumps	
	3 Product classification	375
	3.1 Temperature class and explosion group	
Section 11	Fire Protection and Extinction	
	1 General	377
	1.1 Fire safety requirements	
	1.2 Fire mains and hydrants	
	1.3 Water-spray system	
	1.4 Dry chemical powder fire-extinguishing systems	
	1.5 Enclosed spaces containing cargo handling equipment	
	1.6 Firefighter's outfits	
Section 12	Artificial Ventilation in the Cargo Area	
	1 General	382
	1.1 Scope	
	1.2 Spaces required to be entered during normal cargo handling operations	
	1.3 Spaces not normally entered	
Section 13	Instrumentation and Automation Systems	
	1 General	384
	1.1	
	2 Level indicators for cargo tanks	385
	2.1 General	

Table of Content

	3	Overflow control	385
	3.1	General	
	4	Pressure monitoring	386
	4.1	General	
	5	Temperature indicating devices	386
	5.1	General	
	6	Gas detection	386
	6.1	General	
	7	Additional requirements for containment systems requiring a secondary barrier	388
	7.1	Integrity of barriers	
	7.2	Temperature indication devices	
	8	Automation systems	389
	8.1	General	
	9	System integration	389
	9.1	General	
Section 14	Personnel Protection		
	1	General	390
	1.1	Protective equipment	
	1.2	First-aid equipment	
	1.3	Safety equipment	
	1.4	Personal protection requirements for individual products	
Section 15	Filling Limits for Cargo Tanks		
	1	General	392
	1.1	Definitions	
	1.2	General requirements	
	1.3	Default filling limit	
	1.4	Determination of increased filling limit	
	1.5	Maximum loading unit	
	1.6	Information to be provided to the Master	
Section 16	Use of Cargo as Fuel		
	1	General	394
	1.1		
	2	Use of cargo vapour as fuel	394
	2.1	General	
	3	Arrangement of spaces containing gas consumers	394
	3.1	General	
	4	Gas fuel supply	394
	4.1	General	
	4.2	Leak detection	
	4.3	Routeing of fuel supply pipes	
	4.4	Requirements for gas fuel supply with pressure greater than 1 MPa	
	4.5	Gas consumer isolation	
	4.6	Spaces containing gas consumers	
	4.7	Piping and ducting construction	
	4.8	Gas detection	

Table of Content

5	Gas fuel plant and related storage tanks	398
	5.1 Provision of gas fuel	
	5.2 Remote stops	
	5.3 Compressors	
	5.4 Heating and cooling mediums	
	5.5 Piping and pressure vessels	
6	Special requirements for main boilers	399
	6.1 Arrangements	
	6.2 Combustion equipment	
	6.3 Safety	
7	Special requirements for gas-fired internal combustion engines	399
	7.1 General	
	7.2 Gas fuel supply to engines with fuel injection pressure greater than 1 MPa	
	7.3 Shut-off of gas fuel supply with pressure greater than 1 MPa	
	7.4 Emergency stop of dual fuel engines with fuel injection pressure greater than 1 MPa	
	7.5 Requirements on dual fuel engines	
	7.6 Arrangements	
	7.7 Combustion equipment	
	7.8 Safety	
8	Special requirements for gas turbine	401
	8.1 Arrangements	
	8.2 Combustion equipment	
	8.3 Safety	
9	Alternative fuels and technologies	401
	9.1 General	
Section 17 Special Requirements		
1	General	402
	1.1 Application	
2	Materials of construction	402
	2.1 General	
3	Independent tanks	402
	3.1 General	
4	Refrigeration systems	402
	4.1 General	
5	Cargoes requiring type 1G ship	403
	5.1 General	
6	Exclusion of air from vapour spaces	403
	6.1 General	
7	Moisture control	403
	7.1 General	
8	Inhibition	403
	8.1 General	
9	Flame screens on vent outlets	404
	9.1 General	
10	Maximum allowable quantity of cargo per tank	404
	10.1 General	
11	Cargo pumps and discharge arrangements	404
	11.1 General	

Table of Content

12	Ammonia	404
	12.1 General	
13	Chlorine	405
	13.1 Cargo containment system	
	13.2 Cargo piping systems	
	13.3 Materials	
	13.4 Instrumentation: safety devices	
	13.5 Personnel protection	
	13.6 Filling limits for cargo tanks	
14	Ethylene oxide	406
	14.1 General	
15	Separate piping systems	407
	15.1 General	
16	Methyl acetylene-propadiene mixtures	407
	16.1 General	
17	Nitrogen	408
	17.1 General	
18	Propylene oxide and mixtures of ethylene oxide-propylene oxide with ethylene oxide content of not more than 30% by weight	408
	18.1 General	
19	Vinyl chloride	410
	19.1 General	
20	Mixed C4 cargoes	410
	20.1 General	
21	Carbon dioxide: high purity	410
	21.1 General	
22	Carbon dioxide: reclaimed quality	411
	22.1 General	
Section 18 Operating Requirements		
1	General	412
	1.1	
2	Cargo operating manual	412
	2.1 General	
3	Cargo emergency shutdown (ESD) system	412
	3.1 General	
	3.2 ESD valve requirements	
	3.3 ESD system controls	
	3.4 Additional shutdowns	
	3.5 Pre-operations testing	
	3.6 Testing	
Section 19 Summary of Minimum Requirements		
1	General	416
	1.1 Explanatory notes to the summary of minimum requirements	
2	Additional information on products	416
	2.1	

Table of Content

Section 20	Hull Scantling	
1	General	420
	1.1 Application	
2	Flooding for ships with independent tanks	420
	2.1 General	
3	Finite element model	420
	3.1 General	
	3.2 Structural modeling	
	3.3 Load combinations for direct strength analysis	
	3.4 Yielding strength criteria	
	3.5 Buckling check	
4	Membrane tanks	422
	4.1 General	
	4.2 Sloshing loads	
	4.3 Collision loads	
5	Structural details	422
	5.1 General	
	5.2 Local structural strength analysis	
	5.3 Connections of inner bottom with transverse cofferdam bulkheads	

Appendix 1	Guidance for Calculation of Pressures and Accelerations	
1	Guidance to detailed calculation of internal pressure for static design purpose	423
	1.1 Calculation of dynamic liquid pressure	
	1.2 Calculation of acceleration components	
2	Internal pressure for integral tanks	427
	2.1 General	
3	Guidance to detailed calculation of pressure for a static heel angle of 30°C	427
	3.1 Internal pressure calculation	
	3.2 Sea pressure calculation	
4	Calculation of dynamic pressure for collision loads	428
	4.1 General	

Appendix 2	Correspondances between Part D, Chapter 9 and the IGC Code	
1	General	429
	1.1	

Chapter 10 Tankers

Section 1	General	
1	General	439
	1.1 Application	
Section 2	Hull and Stability	
1	General	440
	1.1 Documents to be submitted	
2	General arrangement	440
	2.1 Compartment arrangement	

Table of Content

3	Stability	440
	3.1 Intact stability	
4	Design loads	440
	4.1 Loading conditions for longitudinal strength assessment	
	4.2 Load combinations for direct strength analysis	
5	Hull scantlings	441
	5.1 Strength check with respect to stresses due to the temperature gradient	
6	Scantlings of independent tank structures	441
	6.1 General	
7	Supports of independent tanks	441
	7.1 General	
8	Other structures	441
	8.1 Machinery space	
9	Construction and testing	441
	9.1 Special structural details	
Section 3	Machinery and Cargo Systems	
1	General	442
	1.1 Documents to be submitted	
2	Piping systems	442
	2.1 General	
	2.2 Cargo piping and pumping	
	2.3 Air pipes	
	2.4 Refrigerating installations	
	2.5 Cargo tank cleaning systems	
	2.6 Additional requirements for ships carrying category Z substances	

Chapter 11 Passenger Ships

Section 1 General

1	General	445
	1.1 Application	

Section 2 Ship Arrangement

1	General	446
	1.1 Definitions	
2	General arrangement design	446
	2.1 Openings in watertight bulkheads below the bulkhead deck	
	2.2 Openings in bulkheads above the bulkhead deck	
	2.3 Doors	
	2.4 Ballast compartment arrangement	
	2.5 Machinery compartment arrangement	

Section 3 Hull and Stability

1	General	452
	1.1 Documents to be submitted	

Table of Content

	2	Stability	452
		2.1 Definitions	
		2.2 Intact stability	
		2.3 Damage stability for ships where SDS notation has been required	
	3	Structure design principles	457
		3.1 Hull structure	
	4	Design loads	457
		4.1 Loads on deck	
		4.2 Sea pressures	
	5	Hull girder strength	458
		5.1 Basic criteria	
		5.2 Global transverse strength	
	6	Hull scantlings	458
		6.1 Balcony doors	
Section 4		Machinery and Cargo System	
	1	Bilge system	459
		1.1 General	
		1.2 Bilge pumps	
		1.3 Direct bilge suction	
		1.4 Control location	
		1.5 Provision against bilge system damage	
		1.6 Drainage and pumping arrangements for vehicle, special category and ro-ro spaces protected by fixed pressure water-spraying systems	
	2	Ballast system	461
		2.1	
	3	Miscellaneous requirements	461
		3.1 Steering gear	
		3.2 Oil-level gauges	
		3.3 Watertight doors	
Section 5		Electrical Installations	
	1	General	462
		1.1 Documentation to be submitted	
		1.2 Electrical distribution and protection	
		1.3 Flooding detection systems for passenger ships carrying 36 or more persons	
	2	Emergency source of electrical power and emergency installations	462
		2.1 General	
		2.2 Distribution of electrical power	
		2.3 Low-location lighting	
	3	General emergency alarm and public address systems	466
		3.1 General emergency alarm system	
		3.2 Public address system	
		3.3 Combined general emergency alarm - public address system	
	4	Installation	468
		4.1 Section and distribution boards	
	5	Type approved components	468
		5.1	

Table of Content

Appendix 1	Calculation Method for Cross-Flooding Arrangements	
1	Calculation method for cross-flooding arrangements	469
1.1	Definitions	
1.2	Cross-flooding area	

Chapter 12 Ro-Ro Passenger Ships

Section 1 General

1	General	476
1.1	Application	

Section 2 Ship Arrangement

1	General	477
1.1	Definitions	
2	General arrangement design	477
2.1	Number and disposition of transverse watertight bulkheads	
2.2	Openings in watertight bulkheads below the bulkhead deck	
2.3	Doors	
2.4	Openings in bulkheads above the bulkhead deck	
2.5	Integrity of the hull and superstructure, damage prevention and control	
2.6	Ballast compartment arrangement	
2.7	Machinery compartment arrangement	
2.8	Passenger spaces in ro-ro ships	

Section 3 Hull and Stability

1	General	484
1.1	Documents to be submitted	
2	Stability	484
2.1	Definitions	
2.2	Intact stability	
2.3	Damage stability for ships where SDS notation has been required	
3	Structure design principles	490
3.1	General	
3.2	Hull structure	
4	Design loads	490
4.1	Loads on deck	
4.2	Lowest 0,5 m of bulkheads forming vertical division along escape routes	
5	Hull girder strength	490
5.1	Basic criteria	
5.2	Global transverse strength	
6	Hull scantlings	490
6.1	Plating	
6.2	Ordinary stiffeners	
6.3	Primary supporting members	
7	Other structures	491
7.1	Superstructures and deckhouses	
8	Construction and testing	491
8.1	Special structural details	

Table of Content

Section 4 Electrical Installations

1	General	492
1.1	Applicable requirements	
1.2	Documentation to be submitted	
1.3	Safety characteristics	
1.4	Flooding detection systems for passenger ships carrying 36 or more persons	
2	Supplementary emergency lighting	492
2.1		
3	Installation	492
3.1	Installations in special category spaces situated above the bulkhead deck	
3.2	Installations in special category spaces situated below the bulkhead deck	
3.3	Installations in cargo spaces other than special category spaces intended for the carriage of motor vehicles	
3.4	Protection of socket outlets in vehicle spaces	
4	Type approved components	494
4.1		

Chapter 13 Ships for Dredging Activity

Section 1 General

1	General	496
1.1	Application	
1.2	Documents to be submitted	

Section 2 Hull and Stability

1	Stability	498
1.1	Intact stability	
1.2	Damage stability where the additional class notation SDS has been requested	
2	Structure design principles	500
2.1	General	
2.2	Longitudinal members in the area of the hopper well	
2.3	Transverse members in the area of the hopper well	
2.4	Arrangements relating to suction pipes	
2.5	Areas subject to heavy wear	
2.6	Reinforcements for grounding	
2.7	Bolted structures	
3	Design loads	505
3.1	General	
3.2	Loading conditions	
3.3	Hull girder loads for dredgers, hopper dredgers and hopper units of more than 65 m in length	
3.4	Hull girder loads for split hopper dredgers and split hopper units of more than 65 m in length	
3.5	Internal pressures in hopper well	
4	Hull girder strength of dredgers, hopper dredgers and hopper units	512
4.1	General	
4.2	Midship section modulus	
5	Hull girder strength of split hopper dredgers and split hopper units	512
5.1	General	
5.2	Definitions	
5.3	Hull girder stress	
5.4	Checking criteria	

Table of Content

6	Hull scantlings	514
	6.1 General	
	6.2 Hull girder normal stress for split hopper dredgers and split hopper units of more than 65 m in length	
	6.3 Minimum net thicknesses of plating	
	6.4 Well bulkhead and cellular keel platings	
	6.5 Transversely framed bottoms	
7	Fatigue	515
	7.1 General	
8	Hopper dredgers and hopper units: checking of hopper well structure	515
	8.1 General	
	8.2 Floors, webs, trunks, strongbeams and girders	
9	Split hopper dredgers and split hopper units: superstructure hinges	516
	9.1 General	
	9.2 Arrangements	
	9.3 Materials used for the hinges	
	9.4 Forces	
	9.5 Scantlings of the hinges	
10	Split hopper dredgers and split hopper units: decks hinges, hydraulic jack connections and chocks	520
	10.1 General	
	10.2 Arrangements	
	10.3 Static forces	
	10.4 Dynamic forces	
	10.5 Scantlings	
11	Split hopper dredgers and split hopper units: hydraulic jacks and associated piping systems	523
	11.1 General	
	11.2 Definitions	
	11.3 Arrangements	
	11.4 Scantling of jacks	
	11.5 Inspection and testing	
	11.6 Relief valve setting	
12	Rudders	524
	12.1 General	
	12.2 Additional requirements for split hopper dredgers and split hopper units	
13	Equipment	524
	13.1 General	
	13.2 Additional requirements for split hopper dredgers and split hopper units	
	13.3 Towlines and mooring lines	

Section 3 Machinery and Dredging Systems

1	General	527
	1.1 Application	
2	Dredging system	527
	2.1 Attachment of dredging equipment to the hull	
3	Steering gear of split hopper dredgers and split hopper units	527
	3.1 General	
	3.2 Design of the steering gear	
	3.3 Synchronisation	
4	Testing of dredging equipment	527
	4.1 On board testing	

Table of Content

Appendix 1 Guidance on Calculation of Transverse Strength Hopper Well Structure		
1	Hopper dredgers and hopper units: checking of hopper well structure	528
	1.1 General	
2	Floors	528
	2.1 General	
	2.2 Different types of bottom and valves used	
	2.3 Load borne by floors	
	2.4 Shear force diagrams	
	2.5 Bending moments for each elementary load	
	2.6 Resultant bending moment	
	2.7 Normal load	
	2.8 Differential opening valves	
	2.9 Buckling of upper flange	
3	Strong beams at deck level	532
	3.1 Forces acting on strong beams	
	3.2 Sectional area of strong beams	
4	Brackets for trunks	533
	4.1 General	
5	Girders supporting the hydraulic cylinder in the hopper spaces (bottom door types 1, 2 and 3)	533
	5.1	

Chapter 14 Non-Propelled Units

Section 1 General

1	General	536
	1.1 Application	

Section 2 Hull and Stability

1	General	537
	1.1 Application	
	1.2 Additional class notations for lifting appliances of ships with service notation pontoon - crane	
2	Stability	537
	2.1 Intact stability for ships with service notation pontoon or pontoon - crane	
	2.2 Additional intact stability criteria for ships with service notation pontoon - crane	
3	Structure design principles	538
	3.1 Hull structure	
	3.2 Lifting appliances	
4	Hull girder strength	538
	4.1 Yielding check	
5	Hull scantlings	539
	5.1 General	
	5.2 Hull scantlings of non-propelled units with the service notation pontoon fitted with arrangements and systems for launching operations	
	5.3 Hull scantlings of non-propelled units with service notation pontoon - crane	
6	Hull outfitting	540
	6.1 Equipment	

Table of Content

Section 3 Machinery and Systems

1	General	541
1.1	Application	
1.2	Documents to be submitted	
2	Bilge system	541
2.1	Bilge system in ships having no source of electrical power	
2.2	Bilge system in ships having a source of electrical power	

Chapter 15 Fishing Vessels

Section 1 General

1	General	544
1.1	Application	

Section 2 Ship Arrangement

1	General	545
1.1	Definitions	
2	General arrangement design	545
2.1	Subdivision arrangement	

Section 3 Hull and Stability

1	General	546
1.1	Documents to be submitted	
2	Stability	546
2.1	Intact stability	
3	Design loads	547
3.1	Fish holds	
3.2	Working deck	
4	Hull scantlings	547
4.1	Fish holds	
4.2	Bottom, side and decks plating	
4.3	Aft ramp	
5	Arrangement for hull and superstructure openings	547
5.1	General	
6	Lifting appliances and fishing devices	547
6.1	General	
6.2	Design loads	
6.3	Strength check	
7	Hull outfitting	548
7.1	Rudder stock scantlings	
7.2	Equipment	
8	Protection of hull metallic structures	550
8.1	Protection of cargo sides by battens	
8.2	Deck composition	

Table of Content

Section 4 Machinery

1	General	551
1.1	Application	
1.2	Documents to be submitted	
1.3	Tests - Trials in ships $L \geq 24$ m	
1.4	Tests - Trials in ships $L < 24$ m	
1.5	General requirements applicable to all piping systems in ships $L \geq 24$ m	
1.6	General requirements applicable to all piping systems in ships $L < 24$ m	
1.7	Sea inlets and overboard discharges in ships $L \geq 24$ m	
1.8	Sea inlets and ship side valves in ships $L < 24$ m	
1.9	Non-metallic rigid pipes in ships $L \geq 24$ m	
1.10	Non-metallic rigid pipes in ships $L < 24$ m	
1.11	Flexible hoses and expansion joints	
1.12	Metallic flexible pipes and joints	
2	Bilge system in ships $L \geq 24$ m	556
2.1	General	
2.2	Design of the bilge system	
2.3	Bilge pumps	
2.4	Size of bilge pipes	
2.5	Bilge piping arrangement	
2.6	Materials	
3	Bilge system in ships $L < 24$ m	559
3.1	General	
3.2	Pumps and ejectors	
3.3	Size of bilge pipes	
3.4	Arrangement of bilge lines and their accessories	
4	Scuppers and sanitary discharges	561
4.1	Principle	
4.2	General	
4.3	Discharges through manned machinery spaces	
4.4	Materials	
5	Air pipes and sounding devices in ships $L \geq 24$ m	561
5.1	Air pipes	
5.2	Sounding and level gauging devices	
6	Air pipes and sounding devices in ships $L < 24$ m	563
6.1	Air pipes	
6.2	Sounding and level gauging devices	
7	Ventilation in ships ≥ 24 m	564
7.1		
8	Ventilation in ships < 24 m	564
8.1		
9	Engine cooling systems in ships $L \geq 24$ m	564
9.1		
10	Engine cooling systems in ships $L < 24$ m	564
10.1	Principle	
10.2	Motorships	
10.3	Fresh water cooling system	
10.4	Cooling pumps	
10.5	Sea inlets	
10.6	Filters	
10.7	Operating control	
10.8	Materials	
11	Oil fuel systems in ships $L \geq 24$m	565
11.1		

Table of Content

12	Oil fuel systems in ships L < 24m	565
	12.1 General	
	12.2 Oil fuel tanks and bunkers	
	12.3 Transfer pipes	
	12.4 Oil fuel supply to engines	
	12.5 Materials - Construction	
13	Lubricating oil systems in ships L ≥ 24 m	567
	13.1	
14	Lubricating oil systems in ships L < 24 m	567
	14.1 General	
	14.2 Lubricating pumps	
	14.3 Filters	
	14.4 Safety devices	
15	Hydraulic systems in ships L ≥ 24 m	567
	15.1	
16	Hydraulic systems in ships L < 24 m	567
	16.1 General	
	16.2 Safety and monitoring devices	
17	Compressed air systems in ships L ≥ 24 m	567
	17.1	
18	Compressed air systems in ships L < 24 m	568
	18.1	
	18.2 Accessories for compressed air systems	
	18.3 Arrangement of compressed air systems	
	18.4 Construction - Material	
19	Exhaust gas systems in ships L ≥ 24 m	568
	19.1	
20	Exhaust gas systems in ships L < 24 m	568
	20.1 Hull outlet	
	20.2 Cooling and lagging	
	20.3 Water-cooled exhaust gas pipes	
21	Refrigeration systems for the preservation of the catch	568
	21.1 General	
	21.2 Design of refrigeration systems	
	21.3 Arrangement of the refrigerating machinery spaces and refrigerating rooms	
	21.4 Breathing apparatus	
22	Propelling and auxiliary machinery in ships L ≥ 24 m	569
	22.1	
23	Propelling and auxiliary machinery in ships L < 24 m	569
	23.1 Shafting	
	23.2 Shaft accessories	
24	Steering gear	571
	24.1 Application	
	24.2 General	
	24.3 Strength, performance and power operation of the steering gear	
	24.4 Control of the steering gear	
	24.5 Availability	
Section 5 Electrical Installations		
1	General	573
	1.1 Application	

Table of Content

	2	Documentation to be submitted	573
		2.1	
	3	Type approved components	573
		3.1	
	4	General requirements for system design, location and installation	573
		4.1 Design and construction	
		4.2 Distribution	
		4.3 Main source of electrical power	
		4.4 Emergency source of electrical power	
		4.5 Precaution against shock, fire and other hazards of electrical origin	
		4.6 Engineers' alarm	
		4.7 Steering gear	
		4.8 Fire detection and fire alarm	
		4.9 Alarm - Communication	
		4.10 Final sub-circuits	
		4.11 Electric cables	
		4.12 Switchboard	
		4.13 Rotating electrical machines	
		4.14 Batteries	
	5	Lightning protection	580
		5.1 Application	
Section 6		Fire Protection	
	1	General	581
		1.1 Application	
		1.2 National regulations	
		1.3 Type approved products	
		1.4 Definitions	
	2	Water fire-fighting system	582
		2.1 General	
		2.2 Number and type of fire pumps	
		2.3 Characteristics and arrangement of fire pumps	
		2.4 Fire main, hydrants and hoses	
	3	Fire-extinguishing appliances in machinery spaces	584
		3.1 Fixed fire-extinguishing systems	
		3.2 Additional fire-extinguishing arrangements	
	4	Fire extinguishers	585
		4.1 Design and installation of fire extinguishers	
		4.2 Arrangement of fire extinguishers in accommodation and service spaces	
	5	Structural fire protection	586
		5.1	
		5.2 Ships of 45 m in length and over	
		5.3 Ships of 24 m in length and over but less than 45 m	
		5.4 Ships of less than 24 m in length	
	6	Ventilation systems	588
		6.1	
	7	Prevention of fire	589
		7.1	
	8	Means of escape	590
		8.1	
	9	Fire detection	590
		9.1	

Table of Content

10	Storage of gas cylinders and dangerous materials	590
	10.1	

Chapter 16 Offshore Patrol Vessels

Section 1 General

1	General	592
	1.1 Application	
	1.2 Number of persons on board	

Section 2 Stability

1	General	594
	1.1 Application	
2	Intact Stability	594
	2.1 Maximum turning angle	
	2.2 Crowding angle for offshore patrol vessels carrying more than 60 persons	
3	Damage stability	594
	3.1 Offshore patrol vessels carrying more than 60 persons	
	3.2 Bottom damages	
4	Damage control documentation for ships greater than or equal to 500 GT	595
	4.1	

Section 3 Machinery

1	General	596
	1.1 Application	
	1.2 Capacity of service tanks for offshore patrol vessels with $GT \geq 500$	
	1.3 Progressive flooding	
	1.4 Bilge pumping after flooding	

Section 4 Electricity and Automation

1	General	597
	1.1 Application	
	1.2 General alarm for ships with $GT < 500$	
	1.3 Emergency source of electrical power for ships with $GT \geq 500$	
	1.4 Public address system for ships with $GT \geq 500$	

Section 5 Fire safety

1	General	598
	1.1 Application	
2	Materials	598
	2.1 Steel or equivalent	
3	Specific requirements	598
	3.1 Offshore patrol vessels carrying more than 60 persons	
	3.2 Ammunition storage compartments	

Part D

Service Notations

CHAPTER 1

RO-RO CARGO SHIPS AND PURE CAR AND/OR TRUCK CARRIERS

Section 1	General
Section 2	Hull and Stability
Section 3	Machinery and Systems
Section 4	Electrical Installations

Section 1 General

1 Application

1.1

1.1.1 Ships complying with the requirements of this Chapter are eligible for the assignment of one of the service notation **ro-ro cargo ship, PCTC or PCC**, as defined in Pt A, Ch 1, Sec 2, [4.2.3] and Pt A, Ch 1, Sec 2, [4.2.4].

1.1.2 Ships dealt with in this Chapter are to comply with:

- Part A of the Rules,
- NR216 Materials and Welding.
- applicable requirements according to Tab 1.

1.1.3 Additional guidance for arrangement and structural assessment is provided in NI640 Guidance Note for Structural Assessment of Passenger Ships and Ro-ro Ships.

Table 1 : Applicable requirements

Item		Greater than or equal to 500 GT	Less than 500 GT
Ship arrangement	L ≥ 65 or 90 m (1)	• Part B	• NR566
	L < 65 or 90 m (1)	• NR600	• NR566
Hull	L ≥ 65 or 90 m (1)	• Part B • Ch 1, Sec 2	• Part B • Ch 1, Sec 2
	L < 65 or 90 m (1)	• NR600	• NR600
Stability		• Part B • Ch 1, Sec 2	• NR566 • Ch 1, Sec 2
Machinery and cargo systems		• Part C • Ch 1, Sec 3	• NR566 • Ch 1, Sec 3
Electrical installations		• Part C • Ch 1, Sec 4	• NR566 • Ch 1, Sec 4
Automation		• Part C	• NR566
Fire protection, detection and extinction		• Part C	• NR566
<p>(1) Refer to the scope of application of NR600.</p> <p>Note 1: NR566: Hull Arrangement, Stability and Systems for Ships less than 500 GT. NR600: Hull Structure and Arrangement for the Classification of Cargo Ships less than 65 m and Non Cargo Ships less than 90 m.</p>			

Section 2 Hull and Stability

1 General

1.1 Application

1.1.1 The requirements of this Section apply to multi-deck ships with double bottom and, in some cases, with wing tanks up to the lowest deck above the full load waterline, intended for the carriage of:

- vehicles which embark and disembark on their own wheels, and/or goods in or on pallets or containers which can be loaded and unloaded by means of wheeled vehicles
- railway cars, on fixed rails, which embark and disembark on their own wheels.

1.2 Documents to be submitted

1.2.1 In addition to the documentation requested in Part B, the following documents are to be submitted:

- operating and maintenance manual of bow, side and stern doors and ramps (see Pt B, Ch 11, Sec 6 and Pt B, Ch 11, Sec 7)
- plan of design loads on deck
- plan of arrangement of motor vehicles, railway cars and/or other types of vehicles which are intended to be carried, indicating securing and load bearing arrangements
- characteristics of motor vehicles, railways cars and/or other types of vehicles which are intended to be carried: (as applicable) axle load, axle spacing, number of wheels per axle, wheel spacing, size of tyre print.

2 Stability

2.1 Damage stability requirements for ship where additional class notation SDS is required

2.1.1 A **ro-ro cargo ship, PCTC or PCC**, equal to or greater than 80 m in length where additional class notation **SDS** is required (see Pt A, Ch 1, Sec 2, [6.17.1]) is to comply with the subdivision and damage stability criteria in Pt B, Ch 3, App 3.

3 Structure design principles

3.1 Wood sheathing

3.1.1 Wood sheathing is recommended for caterpillar trucks and unusual vehicles.

It is recommended that a piece of wood of suitable thickness is provided under each crutch in order to distribute the mass over the plate and the nearest stiffeners.

4 Design loads

4.1 Load combinations for direct strength analysis

4.1.1 The load combinations defined in NI640, App 1, [4] are to be considered for direct strength analysis.

5 Global strength

5.1 Hull girder strength

5.1.1 In addition to the requirements in Pt B, Ch 6, Sec 1, [1.3] and Pt B, Ch 7, Sec 6, [1.1.2], the contribution of the hull structures up to the strength deck to the longitudinal strength is to be assessed through a finite element analysis of the whole ship in the following cases:

- when the size of openings in side shell and/or longitudinal bulkheads located below the strength deck decreases significantly the capability of the plating to transmit shear forces to the strength deck
- when the ends of superstructures which are required to contribute to longitudinal strength may be considered not effectively connected to the hull structures.

5.2 Global transverse strength

5.2.1 The behaviour of the ship primary structural members under racking effects due to transverse forces induced by transverse accelerations is to be investigated according to Pt B, Ch 7, App 1, or by means of a complete ship model according to NI 640.

6 Construction and testing

6.1 Special structural details

6.1.1 The specific requirements in Pt B, Ch 13, Sec 5, [2] for ships with the service notation **ro-ro cargo ship, PCTC or PCC**, are to be complied with.

Section 3 Machinery and Systems

1 Scuppers and sanitary discharges

1.1 Drainage of ro-ro cargo spaces, intended for the carriage of motor vehicles with fuel in their tanks for their own propulsion

1.1.1 Prevention of build-up of free surfaces

In cargo spaces intended for the carriage of motor vehicles with fuel in their tanks for their own propulsion and fitted with a fixed pressure water-spraying fire-extinguishing system, the drainage arrangement is to be such as to prevent the build-up of free surfaces. If this is not possible, the adverse effect upon stability of the added weight and free surface of water is to be taken into account to the extent deemed necessary by the Society in its approval of the stability information.

1.1.2 Scupper draining

Scuppers from cargo spaces intended for the carriage of motor vehicles with fuel in their tanks for their own propulsion are not to be led to machinery or other places where sources of ignition may be present.

Section 4 Electrical Installations

1 General

1.1 Applicable requirements

1.1.1 In addition to the relevant requirements of Part C, Chapter 2 and those contained in this Section, electrical installations in spaces intended for the carriage of motor vehicles with fuel in their tanks for their propulsion are to comply with those of Part C, Chapter 4.

1.2 Documentation to be submitted

1.2.1 In addition to the documentation requested in Pt C, Ch 2, Sec 1, Tab 1, the following is to be submitted for approval:

- a) plan of hazardous areas
- b) document giving details of types of cables and safety characteristics of the equipment installed in hazardous areas.

Table 1 : Electrical equipment permitted in closed ro-ro cargo spaces

No.	Space description	Electrical equipment	Hazardous area
1	Closed ro-ro cargo spaces except areas under item 3	Electrical equipment complying with one of the following types of protection may be considered: <ol style="list-style-type: none"> a) any type that may be considered for zone 0 b) certified intrinsically safe apparatus Ex(ib) c) simple electrical apparatus and components (e.g. thermocouples, photocells, strain gauges, junction boxes, switching devices), included in intrinsically-safe circuits of category "ib" not capable of storing or generating electrical power or energy in excess of limits stated in the relevant rules, and acceptable to the appropriate authority d) certified flameproof Ex(d) e) certified pressurised Ex(p) f) certified increased safety Ex(e) g) certified encapsulated Ex(m) h) certified sand filled Ex(q) i) certified specially Ex(s) j) cables sheathed with at least one of the following: <ul style="list-style-type: none"> • a non-metallic impervious sheath in combination with braiding or other metallic covering • copper or stainless steel sheath (for mineral-insulated cables only) 	Zone 1
2	Exhaust ventilation ducts	As stated under item 1	Zone 1
3	On condition that the ventilation system is so designed and operated as to provide continuous ventilation of the cargo spaces at the rate of at least 10 air changes per hour whenever vehicles are on board: <ul style="list-style-type: none"> • areas above a height of 450 mm from the deck • areas above a height of 450 mm from each platform for vehicles, if fitted, without openings of sufficient size permitting penetration of petrol gases downward • areas above platforms for vehicles, if fitted, with openings of sufficient size permitting penetration of petrol gases downward 	Electrical equipment complying with one of the following types of protection may be considered: <ol style="list-style-type: none"> a) any type that may be considered for zone 1 b) tested specially for zone 2 (e.g. type "n" protection) c) pressurised, and acceptable to the appropriate authority d) encapsulated, and acceptable to the appropriate authority e) the type which ensures the absence of sparks and arcs and of "hot spots" during its normal operation (minimum class of protection IP55) f) cables sheathed with at least a non-metallic external impervious sheath 	Zone 2

1.3 Safety characteristics

1.3.1 The explosion group and temperature class of electrical equipment of a certified safe type for use with explosive petrol-air mixtures are to be at least IIA and T3.

2 Installation

2.1 Installations in closed ro-ro cargo spaces

2.1.1 Except as provided for in [2.1.2], electrical equipment is to be of a certified safe type as stated in Pt C, Ch 2, Sec 3, [10.1.6] and electrical cables are to be as stated in Pt C, Ch 2, Sec 3, [10.3.2].

2.1.2 Above a height of 450 mm from the deck and from each platform for vehicles, if fitted, except platforms with openings of sufficient size permitting penetration of petrol gases downwards, electrical equipment as stated in Pt C, Ch 2, Sec 3, [10.1.7] and electrical cables as stated in Pt C, Ch 2, Sec 3, [10.3.3] are permitted, on condition that the ventilation system is so designed and operated as to provide continuous ventilation of the cargo spaces at the rate of at least 10 air changes per hour whenever vehicles are on board.

2.1.3 Electrical equipment and cables in an exhaust ventilation duct are to be as stated in [2.1.1].

2.1.4 The requirements in this item are summarised in Tab 1.

2.2 Installations in cargo spaces other than ro-ro cargo spaces but intended for the carriage of motor vehicles

2.2.1 The provisions of [2.1] apply.

2.2.2 All electric circuits terminating in cargo holds are to be provided with multipole linked isolating switches located outside the holds. Provision is to be made for locking in the off position.

This requirement does not apply to safety installations such as fire, smoke or gas detection systems.

3 Type approved components

3.1

3.1.1 Alarm systems for closing devices of openings and water leakage detection systems if of electronic type, as well as television surveillance systems, are to be type approved or in accordance with [3.1.2].

3.1.2 Case-by-case approval based on submission of adequate documentation and execution of tests may also be granted at the discretion of the Society.

Part D

Service Notations

CHAPTER 2

CONTAINER SHIPS

- Section 1 General
- Section 2 Hull and Stability
- Section 3 Machinery and Systems

Section 1 General

1 General

1.1 Application

1.1.1 Ships complying with the requirements of this Chapter are eligible for the assignment of the service notation **container ship**, as defined in Pt A, Ch 1, Sec 2, [4.2.6].

1.1.2 Ships dealt with in this Chapter are to comply with:

- Part A of the Rules
- NR216 Materials and Welding
- applicable requirements according to Tab 1

and the requirements of Pt F, Ch 12, Sec 6, for open-top container ships, as defined in [1.2.1].

1.1.3 Ships assigned the additional service feature **equipped for carriage of containers** are to comply with the requirements of Ch 2, Sec 2 except Ch 2, Sec 2, [4.2]; Ch 2, Sec 2, [7] and Ch 2, Sec 2, [10].

1.2 Definition

1.2.1 Open-top container ships

An "open-top containership" is defined as container ship especially designed so that one or more of the cargo holds need not be fitted with hatch covers.

Table 1 : Applicable requirements

Item		Greater than or equal to 500 GT	Less than 500 GT
Ship arrangement	L ≥ 65 m	• Part B	• NR566
	L < 65 m	• NR600	• NR566
Hull	L ≥ 65 m	• Part B • Ch 2, Sec 2	• Part B • Ch 2, Sec 2
	L < 65 m	• NR600	• NR600
Stability		• Part B • Ch 2, Sec 2	• NR566 • Ch 2, Sec 2
Machinery and cargo systems		• Part C • Ch 2, Sec 3	• NR566 • Ch 2, Sec 3
Electrical installations		• Part C • Ch 2, Sec 3	• NR566 • Ch 2, Sec 3
Automation		• Part C • Ch 2, Sec 3	• NR566 • Ch 2, Sec 3
Fire protection, detection and extinction		• Part C • Ch 2, Sec 3	• NR566 • Ch 2, Sec 3

Note 1:

NR566: Hull Arrangement, Stability and Systems for Ships less than 500 GT.

NR600: Hull Structure and Arrangement for the Classification of Cargo Ships less than 65 m and Non Cargo Ships less than 90 m.

Section 2 Hull and Stability

Symbols

For symbols not defined in this Section, refer to Pt B, Ch 1, Sec 3.

M_{sw-min} : Minimum permissible still water bending moment as defined in Pt B, Ch 5, Sec 4, [2.2.1].

M_{sw-max} : Maximum permissible still water bending moment as defined in Pt B, Ch 5, Sec 4, [2.2.1].

Q_{sw-min} : Minimum permissible still water shear force as defined in Pt B, Ch 5, Sec 4, [2.3.1].

Q_{sw-max} : Maximum permissible still water shear force as defined in Pt B, Ch 5, Sec 4, [2.3.1].

1 General

1.1 Application

1.1.1 The requirements of this Section apply to double bottom ships of double or single side skin construction, intended to carry containers in holds or on decks.

1.1.2 Open-top container ships

In addition to the requirements of this Section, open-top container ships are to comply with the requirements of Pt F, Ch 12, Sec 6.

1.2 Documents and information

1.2.1 Documents to be submitted

Documents are to be submitted as required in Pt B, Ch 1, Sec 4. In addition, the following documents are to be submitted to the Society for review:

- container stowage plan, describing the arrangement of containers in hold, on deck and on hatch covers; the plan shall also include the gross weight of containers and the maximum design weight of container stacks
- list and/or plan of all fixed securing devices as requested in [14]
- fixed cell guides arrangement and scantlings.

1.2.2 Information to be submitted

The following additional information is to be included in the relevant documents:

- the distributions of still water permissible vertical bending moments, vertical shear forces, and the maximum torsional moment in seagoing and harbour conditions, as defined in Pt B, Ch 5, Sec 4, are to be included in the loading manual
- the permissible stack weights for 20' and 40' containers stacks in hold and on deck, as defined in [5.2.2], are to be included on the midship section drawing and in the loading manual

2 Stability

2.1 Intact stability

2.1.1 General

The stability for the loading conditions defined in Pt B, Ch 3, App 2, [1.2.4] is to be in compliance with the requirements of Pt B, Ch 3, Sec 2.

2.1.2 Additional criteria

In addition to [2.1.1], the initial metacentric height is to be equal to or greater than 0,20 m.

2.1.3 Alternative criteria for ships greater than 100 m in length

For ships greater than 100 m in length, the Society may apply the following criteria instead of those in Pt B, Ch 3, Sec 2:

- the area under the righting lever curve (GZ curve), in $m\cdot rad$, is to be not less than $0,009/C$ up to an angle of heel of 30° , and not less than $0,016/C$ up to 40° or the angle of flooding θ_f if this angle is less than 40°
- the area under the righting lever curve (GZ curve), in $m\cdot rad$, between the angles of heel of 30° and 40° or between 30° and θ_f if this angle is less than 40° , is to be not less than $0,006/C$
- the righting lever GZ , in m , is to be at least $0,033/C$ at an angle of heel equal to or greater than 30°
- the maximum righting lever GZ , in m , is to be at least $0,042/C$
- the total area under the righting lever curve (GZ curve), in $m\cdot rad$, up to the angle of flooding θ_f is not to be less than $0,029/C$ where:

C : Coefficient defined by:

$$C = \sqrt{\frac{T}{KG}} \sqrt{\frac{100}{L} \left(\frac{C_B}{C_W}\right)^2 \frac{TD'}{B_m^2}}$$

T : Mean draught, in m

KG : Height of the centre of mass above base, in m, corrected for free surface effect, not be taken as less than T

C_B : Block coefficient

Figure 1 : Definition of dimensions

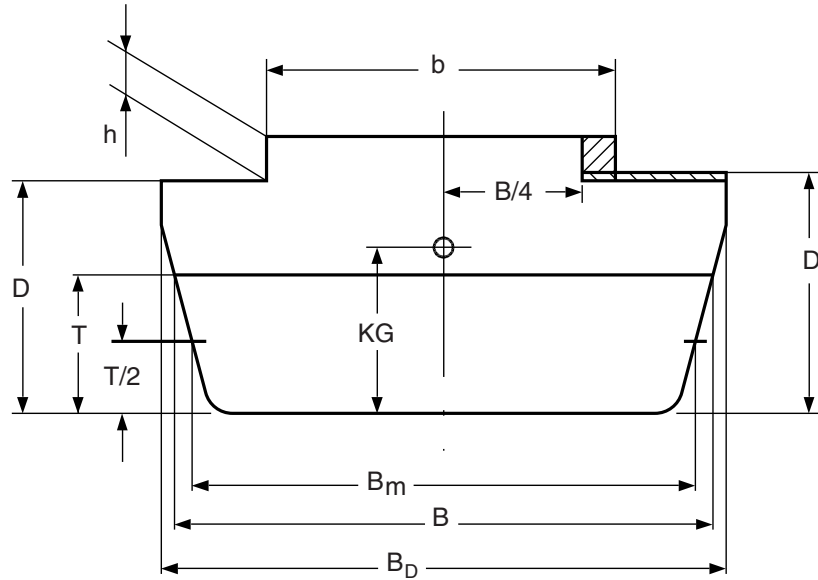
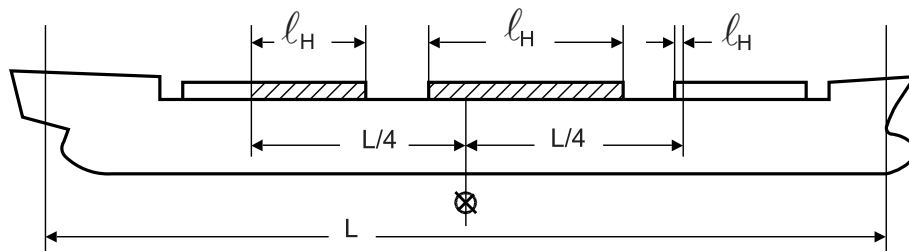

Figure 2 : Definition of dimensions



C_W : Waterplane coefficient

D' : Moulded depth, in m, corrected for defined parts of volumes within the hatch coamings obtained from the following formula:

$$D' = D + \left(\frac{2b - B_D}{B_D}\right) \left(\frac{2 \sum l_H}{L}\right) h$$

h : Mean height, in m, of hatch coamings within $L/4$ forward and aft from amidships (see Fig 1)

b : Mean width, in m, of hatch coamings within $L/4$ forward and aft from amidships (see Fig 1)

B_m, B_D : Breadths, in m, defined in Fig 1

l_H : Length, in m, of each hatch coaming within $L/4$ forward and aft from amidships (see Fig 2).

2.2 Damage stability requirements for ships where the additional class notation SDS is required

2.2.1 General

Any type of container ship with a length equal to or greater than 80 m is to comply with the subdivision and damage stability criteria of Pt B, Ch 3, App 3.

3 Structure design principles

3.1 Ship structure

3.1.1 Design

The ship structure is to be longitudinally or transversely framed with full transverse bulkheads and intermediate web frames.

When single side skin construction is adopted, a torsion box girder at the topsides or an equivalent structure is to be fitted. Typical midship sections are shown in Fig 3 and Fig 4.

Figure 3 : Container ship of double side skin construction

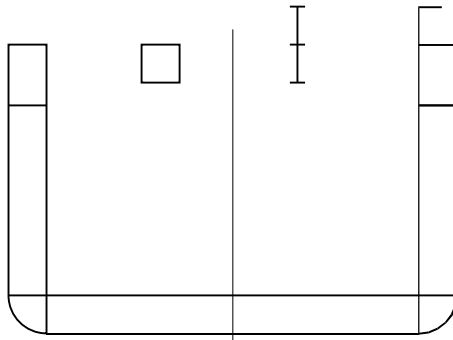
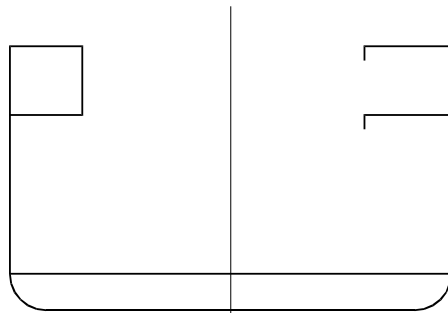

Figure 4 : Container ship of single side skin construction



3.2 Material

3.2.1 The material classes required for the strength deck plating, the sheerstrake and the torsion box girder structure within 0,4 L amidships are to be maintained in way of the entire cargo hold region.

3.2.2 When steel plates of thickness greater than 50 mm, made of material with specified minimum yield stress equal to 460 N/mm² are used in the upper deck region (for upper deck plating, hatch top and side coaming or their attached longitudinals stiffeners), the material grade is at least to be EH.

3.2.3 Prevention of brittle crack propagation

This requirement applies to ships for which steel with minimum specified yield stress R_{eH} of 390 or 460 N/mm² is used for hatch coaming plating.

It gives measures, to be applied in cargo hold region, for prevention of propagation of brittle cracks initiating in block-to-block butt joints of upper deck and hatch side coaming (including top plating and their attached longitudinals).

a) For plating with as-built thickness greater than 50 mm but not greater than 100 mm, measures are to be taken as specified in Tab 1, in which minimum specified yield stress R_{eH} and thickness t refer to hatch coaming top and side platings (not upper deck).

Measures are defined as follows:

- Measure 1: measure for prevention of brittle crack propagation along block-to-block butt joints, and deviation from butt joints into base metal
- Measure 2: measure for prevention of brittle crack propagation from weld areas other than butt joints considered in Measure 1, such as fillets and attachment welds.

When brittle crack arrest steels are used, the minimum specified yield stress of the upper deck is to be not higher than 390. Otherwise other means for preventing the crack initiation and propagation shall be agreed by the Society.

b) For plating with as-built thickness greater than 100 mm, appropriate measures are to be considered on a case-by-case basis by the Society.

c) If the as-built thickness of the hatch coaming structure is equal to or less than 50 mm, measures are not necessary, regardless of the as-built thickness and yield stress of the upper deck.

The following is considered to be an acceptable example of preventive Measure 1:

- a) use of brittle crack arrest steel for upper deck plating, in a way suitable to prevent transmission of crack propagating from hatch coaming to the structure below, and
- b) use of brittle crack arrest steel for hatch side coaming plating, and

c) one of the following arrangements, aiming at creating a discontinuity in weld line:

- shifting block-to-block butt welds of the hatch side coaming and those of the upper deck. This shift is to be not less than 300 mm (see Fig 5)
- providing crack arrest holes in way of the block-to-block butt welds at the region where hatch side coaming weld meets the deck weld. In this case, the fatigue strength of the lower end of the butt weld is to be assessed (see Fig 6)
- including arrest insert plates, of brittle crack arrest steel in way of the block-to-block butt welds at the region where hatch side coaming weld meets the deck weld (see Fig 7).

Table 1 : Measures to prevent propagation of brittle cracks

R_{eH} , in N/mm ²	As-built thickness, in mm	Measures
390	$50 < t \leq 85$	N.A.
	$85 < t \leq 100$	Measure 1 (1) and Measure 2
460 Flux cored arc welding	$50 < t \leq 100$	Measure 1 (1) and Measure 2
460 Electro gas welding	$50 < t \leq 100$	Measure 1 and Measure 2

(1) As an alternative to Measure 1, the shipbuilder may apply enhanced non-destructive testing (particularly time-of-flight diffraction technique) to all block-to-block butt joints over their full length, using stricter defect acceptance criteria, in lieu of ultrasonic testing.

Figure 5 :

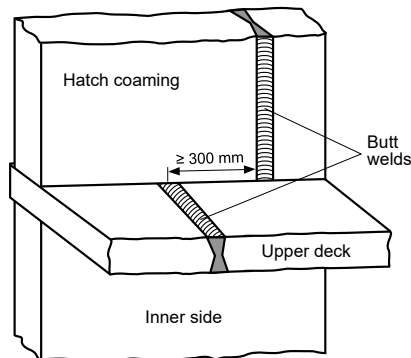

Figure 6 :

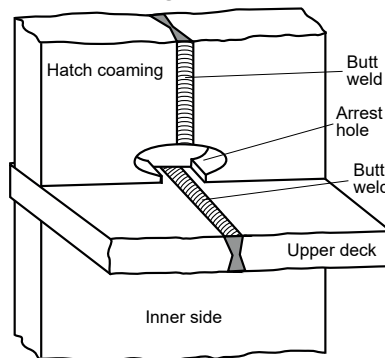
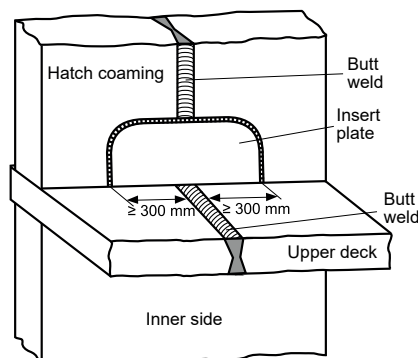

Figure 7 :



As an alternative to items b) and c), the shipbuilder may apply enhanced non-destructive testing (particularly time-of-flight diffraction technique) to all block-to-block butt joints over their full length, using stricter defect acceptance criteria, in lieu of ultrasonic testing.

The procedure and the acceptance criteria of non destructive (NDT) and ultrasonic testing (UT) are to be in accordance with Pt B, Ch 13, Sec 4.

The use of brittle crack arrest steel for upper deck plating, in a way suitable to prevent transmission of crack propagating from hatch coaming to the structure below, is considered to be an acceptable example of preventive Measure 2.

The brittle crack arrest steels used in Measure 1 and Measure 2 are to be selected according to Tab 2 where suffixes CAS1 and CAS2 are defined in NR216 Materials and Welding.

When brittle crack arrest steels are used, the weld joints between the hatch coaming side and the upper deck are to be partial penetration. In the vicinity of ship block joints, alternative weld may be used for the deck and hatch coaming side connection provided additional means for preventing the crack propagation are implemented and agreed by the Society.

Table 2 : Brittle crack arrest steel selection

Structural members plating (1)	Thickness (mm)	Brittle crack arrest steel
Upper deck	$50 < t \leq 100$	EH36CAS1 / FH36CAS1 EH40CAS1 / FH40CAS1
Hatch coaming side	$50 < t \leq 80$	EH40CAS1 / FH40CAS1 EH47CAS1 / FH47CAS1
	$80 < t \leq 100$	EH40CAS2 / FH40CAS2 EH47CAS2 / FH47CAS2
(1) Excluding their attached longitudinals		

3.3 Net scantling approach

3.3.1 Net thickness approach

The applied corrosion is to be taken equal to $0 t_c$ in the following cases:

- calculations of stresses based on cargo hold model (standard mesh, or 3-D beam models) or complete ship model
- calculations of stresses based on local fine mesh or very fine mesh

3.4 Strength principles

3.4.1 Reinforcement under container corners and in way of fixed cargo securing devices and cell guides

Local reinforcement of the hull structure and hatch covers is to be provided under container corners and in way of fixed cargo securing devices and cell guides, if fitted.

The forces applying on the fixed cargo securing devices are to be indicated by the designer. When one of the additional class notations **LASHING**, **LASHING-WW** or **LASHING (specific area)** is granted, these forces may be determined by the Society.

3.5 Bottom structure

3.5.1 Floor spacing

Generally, the floor spacing is to be such that floors are located in way of the container corners. Floors are also to be fitted in way of the watertight bulkheads.

The floor spacing is generally not to be greater than 3,5 m or four times the transverse frame spaces, whichever is the smaller.

3.5.2 Cell guides

The structure of the bottom and inner bottom on which cell guides rest is to be adequately stiffened with doublers, brackets or other equivalent reinforcements.

3.6 Deck structure

3.6.1 Longitudinal hatch coaming

The width of the longitudinal hatch coaming flanges is to be such as to accommodate the hatch covers and their securing arrangements.

The end connections of the longitudinal hatch coamings are to ensure a proper transmission of stresses from the hatch coaming to the supporting structure.

3.6.2 Hatch corners

The stress concentrations in way of the hatch corners are to be checked, in particular in the top part (hatch coaming, upper deck and stringers under deck).

3.6.3 Deck and hatch cover reinforcements

The deck and hatch cover structures are to be reinforced taking into account the loads transmitted by the container corners and cell guides.

3.7 Bulkheads

3.7.1 Transverse torsion box structures in way of transverse bulkheads

Transverse torsion box structures are generally to be provided at the top part of the transverse bulkheads.

They are to be provided with sufficient strength to sustain stress resulting from the shear forces induced at their ends by hull girder torsion effects.

Similar boxes might as well be provided at the bottom part of the transverse bulkheads.

3.7.2 Primary supporting members

The vertical primary supporting members of the transverse bulkheads are to be fitted in line with bottom girders.

Their flanges are to be in line with a double bottom floor.

The strength of the connection between these members and the bottom structure is to be assessed.

3.7.3 Reinforcements in way of cell guides

When cell guides are fitted on transverse or longitudinal bulkheads which form boundaries of the hold, such structures are to be reinforced, taking into account the loads transmitted by the cell guides.

4 Design loads

4.1 Still water hull girder loads

4.1.1 Permissible torsional still water moment in seagoing condition

The permissible torsional still water moment M_{sw-t} , in kN·m, induced by a non-uniform distribution of cargo, consumable liquids and ballast in seagoing condition, is to be considered.

When no specific data is provided by the designer, as a guidance at a preliminary stage, M_{sw-t} may be obtained, from the following formula:

$$M_{sw-t} = 0,04 L B (S_h T_h + S_d T_d)$$

where:

- S_h : Number of container stacks over the breadth B in cargo hold amidships
- T_h : Number of container tiers in cargo hold amidships
- S_d : Number of container stacks over the breadth B on deck amidships
- T_d : Number of container tiers on deck amidships.

4.1.2 Permissible torsional still water moment in harbour/sheltered water

The permissible torsional still water moment M_{sw-t-h} , in kN·m, induced by a non-uniform distribution of cargo, consumable liquids and ballast in the harbour/sheltered water condition, is to be considered.

This value is defined as a constant value over the ship length.

When no specific data is provided by the designer, a preliminary value for M_{sw-t-h} may be taken equal to the permissible torsional still water moment in seagoing condition M_{sw-t} as defined in [4.1.1].

4.1.3 Torsional still water moment for direct calculations in seagoing condition

For direct calculation analysis, the torsional still water moment in seagoing condition $M_{sw-t-LC}$, in kN·m, is to be taken, at any longitudinal position for the considered dynamic load case, as follows:

- For $C_{WT} \geq 0$
 $M_{sw-t-LC} = |f_{lp}| M_{sw-t} (f_{q-a} + f_{q-f})$
- For $C_{WT} < 0$
 $M_{sw-t-LC} = -|f_{lp}| M_{sw-t} (f_{q-a} + f_{q-f})$

where:

- C_{WT} : Load combination factor for wave torsional moment, to be taken as specified in Pt B, Ch 5, Sec 2, for the considered dynamic load case.
- f_{lp} : Factor depending on the longitudinal position, as defined in Pt B, Ch 5, Sec 2
- f_{q-a} , f_{q-f} : Distribution factors, as defined in Pt B, Ch 5, Sec 4, [3.4.1]
- M_{sw-t} : Permissible torsional still water moment in seagoing condition, as defined in [3.1.1].

4.1.4 Torsional still water moment for direct calculations in harbour/sheltered water

For direct calculation analysis, the torsional still water moment in the harbour/sheltered water condition M_{sw-t-p} , in kN.m, is to be taken, at any longitudinal position, as follows:

$$M_{sw-t-p} = f_{lp} M_{sw-t-h} (f_{q-a} + f_{q-f})$$

where:

- f_{lp} : Factor depending on the longitudinal position, as defined in Pt B, Ch 5, Sec 2
- M_{sw-t-h} : Permissible torsional still water moment in harbour/sheltered water, as defined in [4.1.2]
- f_{q-a}, f_{q-f} : Distribution factors, as defined in Pt B, Ch 5, Sec 4, [3.4.1].

4.2 Dynamic hull girder loads

4.2.1 Vertical wave bending moments for strength assessment

The vertical wave bending moments M_{wv-h} and M_{wv-s} , in kN.m, at any longitudinal position, are to be taken as:

- in hogging condition:

$$M_{wv-h} = 1,5 f_R f_S f_{nl-h} f_{m-h} H L^3 C_W f_{BL}^{0,8}$$

- in sagging condition:

$$M_{wv-s} = - 1,5 f_R f_S f_{nl-s} f_{m-s} H L^3 C_W f_{BL}^{0,8}$$

where:

- f_R : Routing factor as defined in Pt B, Ch 5, Sec 3
- f_S : Speed effect coefficient as defined in Pt B, Ch 5, Sec 3
- f_{nl-h} : Coefficient considering non-linear effects applied to hogging, to be taken equal to:

$$f_{nl-h} = 1 + n \cdot \left(0,3 \frac{C_B}{C_W} \sqrt{T_{SC}} - 1 \right)$$

without being taken greater than 1,1

- f_{nl-s} : Coefficient considering non-linear effects applied to sagging, to be taken equal to:

$$f_{nl-s} = 1 + n \cdot \left(4,5 \frac{1 + 0,2 f_{Bow}}{C_W \sqrt{C_B} L^{0,3}} - 1 \right)$$

without being taken less than 1,0

- f_{Bow} : Bow flare shape coefficient, to be taken equal to:

$$f_{Bow} = \frac{A_{DK} - A_{WL}}{0,2 L z_f}$$

- A_{DK} : Projected area to the horizontal plane of deck, in m², including the forecastle deck, extending from 0,8 L forward (see Fig 10)

- A_{WL} : Waterplane area, in m², at scantling draught T_{SC} , extending from 0,8 L forward

- f_{m-h} : Distribution factor for vertical wave bending moment in hogging condition along the ship's length, to be taken as follows (see Fig 8):

- $f_{m-h} = 0,0$ for $x \leq 0$
- $f_{m-h} = 0,15$ for $x = 0,1 L$
- $f_{m-h} = 1,00$ for $0,35 L \leq x \leq 0,55 L$
- $f_{m-h} = 0,25$ for $x = 0,8 L$
- $f_{m-h} = 0,0$ for $x \geq L$

Intermediate values of f_{m-h} are to be obtained by linear interpolation

Figure 8 : Distribution factor f_{m-h}

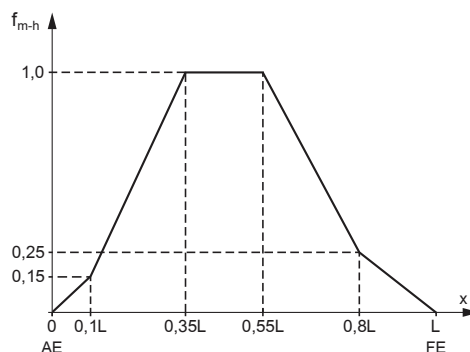

f_{m-s} : Distribution factor for vertical wave bending moment in sagging condition along the ship's length, to be taken as follows (see Fig 9):

- $f_{m-s} = 0,0$ for $x \leq 0$
- $f_{m-s} = 1,0$ for $0,35 L \leq x \leq 0,6 L$
- $f_{m-s} = 0,0$ for $x \geq L$

Intermediate values of f_{m-s} are to be obtained by linear interpolation

z_f : Vertical distance, in m, from the waterline at scantling draught T_{sc} to the deck (or forecastle deck), measured at FE (see Fig 10)

H : Wave parameter, as defined in Pt B, Ch 5, Sec 3, for a reference length L_{ref} calculated with:

$$\alpha = \frac{315}{486} \cdot \frac{1}{C_W^{1,3}}$$

$$f_\alpha = 1,0$$

Figure 9 : Distribution factor f_{m-s}

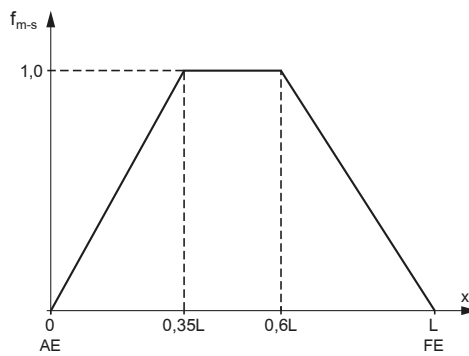
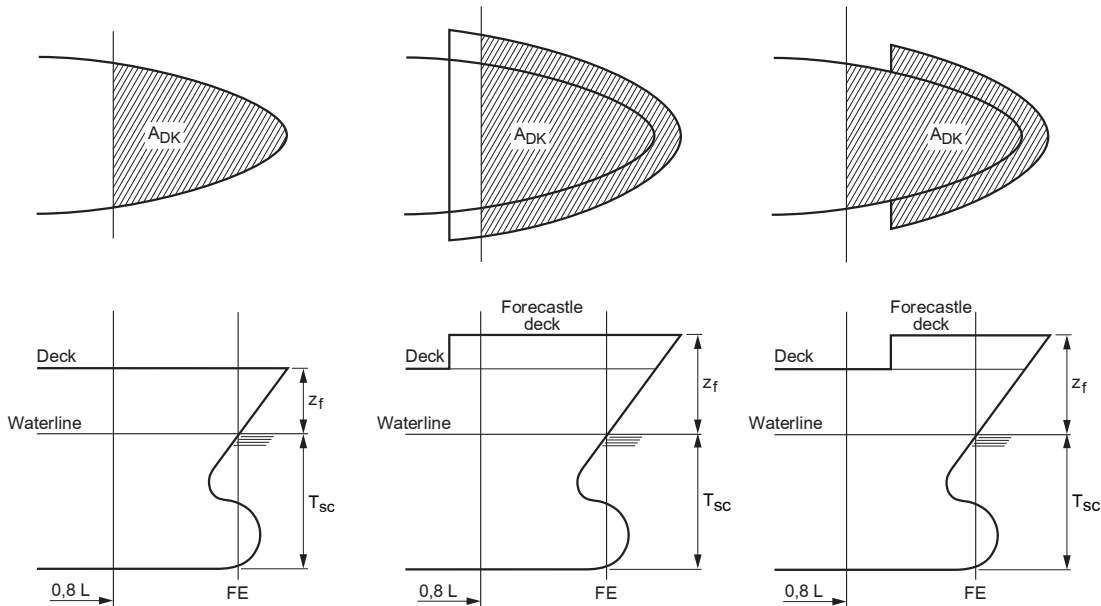

Figure 10 : Projected area A_{DK} and vertical distance z_f



4.2.2 Vertical wave shear forces for strength assessment

The vertical wave shear forces Q_{wv-pos} and Q_{wv-neg} , in kN, at any longitudinal position, are to be taken as follows:

$$Q_{wv-pos} = f_R f_S f_{q-pos} H L^2 C_W f_{BL}^{0,8}$$

$$Q_{wv-neg} = - f_R f_S f_{q-neg} H L^2 C_W f_{BL}^{0,8}$$

where:

f_R : Routing factor as defined in Pt B, Ch 5, Sec 3

f_S : Speed effect coefficient as defined in Pt B, Ch 5, Sec 3

$f_{q\text{-pos}}$: Distribution factor along the ship length for positive wave shear force, to be taken as (see Fig 11):

- $f_{q\text{-pos}} = 0,0$ for $x \leq 0$
- $f_{q\text{-pos}} = 5,2 (0,3 + 0,7f_{nl\text{-h}})$ for $0,15L \leq x \leq 0,3L$
- $f_{q\text{-pos}} = 4,0$ for $0,4L \leq x \leq 0,55L$
- $f_{q\text{-pos}} = 5,7 (0,25 + 0,75f_{nl\text{-s}})$ for $0,65L \leq x \leq 0,85L$
- $f_{q\text{-pos}} = 0,0$ for $x \geq L$

Intermediate values of $f_{q\text{-pos}}$ are to be obtained by linear interpolation

Figure 11 : Distribution factor $f_{q\text{-pos}}$

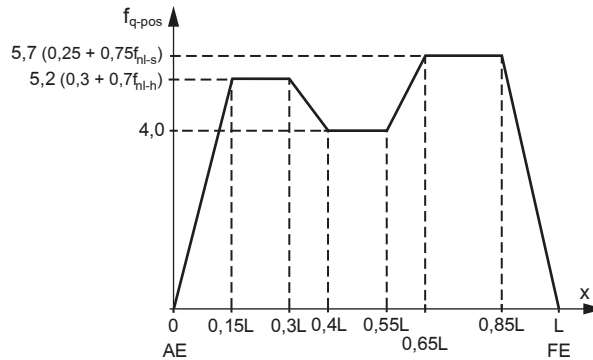

$f_{q\text{-neg}}$: Distribution factor along the ship length for negative wave shear force, to be taken as (see Fig 12):

- $f_{q\text{-neg}} = 1,3 (0,3 + 0,7f_{nl\text{-s}})$ for $x \leq 0$
- $f_{q\text{-neg}} = 5,2 (0,3 + 0,7f_{nl\text{-s}})$ for $0,15L \leq x \leq 0,3L$
- $f_{q\text{-neg}} = 4,0$ for $0,4L \leq x \leq 0,50L$
- $f_{q\text{-neg}} = 5,7 f_{nl\text{-h}}$ for $0,6L \leq x \leq 0,75L$
- $f_{q\text{-neg}} = 0,0$ for $x \geq L$

Intermediate values of $f_{q\text{-neg}}$ are to be obtained by linear interpolation

Figure 12 : Distribution factor $f_{q\text{-neg}}$

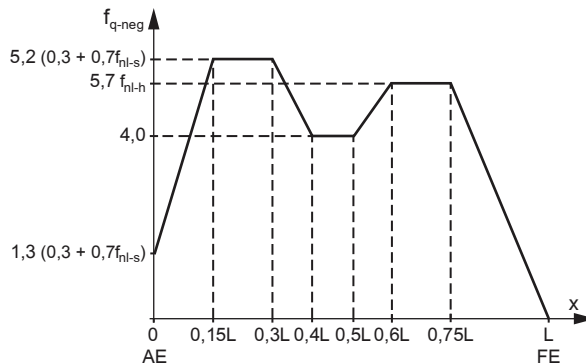

$f_{nl\text{-h}}, f_{nl\text{-s}}$: Coefficients considering non-linear effects and defined in [4.2.1]

H : Wave parameter, as defined in Pt B, Ch 5, Sec 3, for a reference length L_{ref} calculated with:

$$\alpha = \frac{330}{486} \cdot \frac{1}{C_W^{1,3}}$$

$$f_\alpha = 1,0$$

5 Load combinations for direct strength analysis based on partial three-dimensional model

5.1 General

5.1.1 The loading conditions to be considered for three- dimensional analysis are given in:

- [5.3] for strength check of cargo holds
- [5.4] for strength check of fuel oil tanks when deep fuel oil tanks are located in the cargo hold area.

These loading conditions may be adjusted if deemed relevant by the Society.

5.1.2 The load cases to be considered for three-dimensional analysis are given in [5.5].

5.2 Container weight

5.2.1 Maximum number of tiers

It corresponds to the maximum number of tiers on deck and in hold as provided on the container stowage plan.

On a case-by-case basis, for tiers on deck, the maximum number of tiers as provided among all the loading conditions as described in the loading manual might be used, upon agreement by the Society.

5.2.2 Permissible stack weight

The permissible stack weights in hold and on deck, for 20' and 40' containers as referred to in [5.2.3] to [5.2.6], are to be defined in the loading manual and on the midship section, as required in [1.2.2].

5.2.3 Heavy cargo in hold

a) 40' containers

Heavy cargo weight of 40' containers in hold is to be calculated as the permissible stack weight, as defined in [5.2.2], divided by the maximum number of tiers, as defined in [5.2.1].

Note 1: At preliminary stage when the permissible stack weight is not available, the heavy cargo weight of 40' containers in hold may be taken equal to 30,5 T.

b) 20' containers

Heavy cargo weight of 20' containers in hold is to be calculated as the permissible stack weight, as defined in [5.2.2], divided by the maximum number of tiers, as defined in [5.2.1].

A specific value of uniform permissible stack weight of 20' containers might be specified in loading manual and midship section, used for FE calculation. This value should be at least equal to the maximum stack weight of 20' container stacks provided among the different loading conditions of the loading manual.

5.2.4 Heavy cargo on deck

a) 40' containers

Heavy cargo weight of 40' containers on deck is to be calculated as the permissible stack weight, as defined in [5.2.2], divided by the maximum number of tiers, as defined in [5.2.1].

b) 20' containers

Heavy cargo weight of 20' containers on deck is to be calculated as the permissible stack weight, as defined in [5.2.2], divided by the maximum number of tiers, as defined in [5.2.1].

5.2.5 Light cargo in hold

a) 40' containers

Light cargo weight of 40' containers in hold is to be taken as 55% of its related heavy cargo weight, as defined in [5.2.3], not exceeding 16,5 T per container.

b) 20' containers

Light cargo weight of 20' containers in hold is to be taken as the minimum stack weight in holds, selected among homogeneous conditions provided in the loading manual considering the holds filled up to the top, divided by the maximum number of tiers as defined in [5.2.1], without exceeding 8 T per container.

5.2.6 Light cargo on deck

Light cargo weight of 40' containers on deck is to be taken equal to 90% of its related heavy cargo weight, without exceeding 17 T per container.

5.3 Loading conditions for cargo holds strength check

5.3.1 The loading conditions to be considered for cargo hold strength check are given in [5.3.4] to [5.3.8] and are summarized in Tab 3.

5.3.2 For the loading conditions given in [5.3.5] to [5.3.8], all ballast and fuel oil tanks in way of cargo hold model are to be empty.



5.3.3 If deemed necessary by the Society, specific static harbour conditions may have to be considered in addition to the loading conditions given in [5.3.4] to [5.3.8], using permissible hull girder loads for harbour conditions.

5.3.4 Ballast loading condition

Ballast 1 (BL-1):

- all cargo holds to be empty, ballast tanks to be full
- the draught value is to be taken as the minimum ballast draught provided in the loading manual (LM) and the still water bending moment is to be taken from the same condition.

Table 3 : Loading conditions for cargo hold strength check

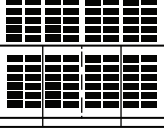
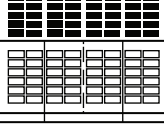
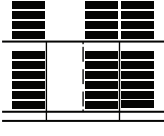
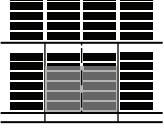
Loading condition	Description	Loading pattern	Container loading (1)	Draught	SWBM	SWSF
BL-1	Ballast		Not loaded	T_{BAL}	from LM	Q_{sw}
HH	Homogeneous (heavy)		Heavy cargo 40'	T_{SC}	M_{sw-max}	Q_{sw}
HL	Homogeneous (light)		Light cargo 40'	T_{SC}	M_{sw-max}	Q_{sw}
HR	Homogeneous (reduced draught)		Heavy cargo 20' If mixed stowage on deck is applicable: Max 20' and 40' stack weight	$\leq 0,9T_{SC}$	M_{sw-min}	Q_{sw}
DL	Maximum deck load		Heavy cargo 20' on deck If mixed stowage on deck is applicable: Max 20, and 40' stack weight. Light cargo 20' in hold	$0,9 T_{SC}$	$M_{sw-min} (2)$	Q_{sw}
OB-1	One bay empty		Heavy cargo 40' One bay empty in hold and on deck (3)	T_{SC}	M_{sw-max}	Q_{sw}
FD	Flooding		Heavy cargo 40' Any cargo hold flooded	T_{FL}	-	-

(1) Container weights are defined in [5.2]. Each stack is to be loaded with the maximum number of tiers, as defined in [5.2.1].
 (2) The minimum vertical still water bending moment taken from all the homogeneous loading conditions in the loading manual may be used.
 (3) A minimum list of loading patterns is defined in Tab 4.

5.3.5 Homogeneous loading conditions

Homogeneous heavy (HH):

- homogeneous 40' containers loaded on deck and in holds
- heavy cargo weight of 40' containers is to be considered as defined in [5.2.3] and [5.2.4]
- scantling draught is to be considered together with the maximum design still water bending moment in hogging.

Homogeneous light (HL):

- homogeneous 40' containers loaded on deck and in holds
- light cargo weight of 40' containers is to be considered as defined in [5.2.5] and [5.2.6]
- scantling draught is to be considered together with the maximum design still water bending moment in hogging.

Homogeneous reduced draught (HR):

- homogeneous 20' containers loaded on deck and in holds. Reduced draught is to be considered together with the minimum design still water bending moment
- reduced draught corresponds to the expected draught amidships when heavy cargo is loaded in the considered holds while lighter cargo is loaded in the other holds.

Reduced draught is not to be taken more than 90% of the scantling draught

- heavy cargo weight of 20' containers is to be considered as defined in [5.2.3].

5.3.6 Maximum deck load loading condition

Maximum deck load (DL):

- maximum stack load of 20' containers on deck and minimum stack load of 20' containers in holds
- light cargo weight of 20' containers in hold is to be taken as defined in [5.2.5]
- heavy cargo weight of 20' containers on deck is to be taken as defined in [5.2.3]
- scantling draught is to be considered together with the minimum still water bending moment, selected among all homogeneous loading conditions described in the loading manual.

5.3.7 One bay empty loading condition

One bay empty 1 (OB-1):

- homogeneous loading is to be considered similarly to HH, as defined in [5.3.5], except one bay to be kept empty in hold and on deck. A minimum list of loading patterns is defined in Tab 4
- scantling draught is to be considered together with the maximum design still water bending moment in hogging.

Table 4 : One bay empty loading condition

Container ship arrangement		Bays to be considered as being empty
Design	Number of bays per hold	
Twin islands	2	Bay located immediately aft of the fore island
		One of the two bays of the second cargo hold aft of the fore island
	3	Bay located immediately aft of the fore island
		Two forward bays in the second cargo hold aft of the fore island (1)
Single island	2	One bay among those located within 0,3 L to 0,7 L
	3	One bay among those located within 0,3 L to 0,7 L and adjacent to a watertight bulkhead
		One bay among those located within 0,3 L to 0,7 L, in the middle of the hold

(1) Two different loading conditions are to be checked, each of them with one of the bays to be considered empty.

5.3.8 Flooding

Flooding (FD):

- homogeneous loading is to be considered similarly to HH, as defined in [5.3.5]. Dynamic loads and hull girder loads are disregarded
- draught T_{FL} is to be considered up to the deepest equilibrium waterline in damaged condition (obtained from applicable damage stability calculations). If this information is not available at design stage, the draught might be considered up to the freeboard deck. It is to be checked at a later stage that the deepest equilibrium waterline remains below the freeboard deck
- the structural analysis is only carried out on the transverse watertight bulkheads.

5.4 Loading conditions for fuel oil tanks

5.4.1 The loading conditions to be considered for fuel oil tank strength check are given in [5.4.3] to [5.4.6] and are summarized in Tab 5.

5.4.2 The actual density of the fuel oil is to be used in the calculation.

If any deckhouse or superstructure is fitted above the fuel oil tanks, inertial loads induced by such structures are to be modelled.

5.4.3 Normal ballast loading conditions

Ballast 2 (BL-2):

- cargo holds are to be empty. All fuel oil tanks are to be fully loaded
- the draught is to be taken as the minimum ballast draught provided in the loading manual.

Ballast 3 (BL-3):

- cargo holds are to be empty. Fuel oil tanks are to be loaded alternately
- the draught is to be taken as the minimum ballast draught provided in the loading manual.

5.4.4 Maximum stack load loading conditions

Maximum stack load 1 (SL-1):

- cargo holds are to be loaded as per HH condition described in [5.3.5]. Fuel oil tanks are to be empty
- scantling draught is to be considered together with the minimum still water bending moment, selected among all homogeneous loading conditions described in the loading manual.

Maximum stack load 2 (SL-2):

- cargo holds are to be loaded as per HH condition described in [5.3.5]. Fuel oil tanks are to be loaded alternately through ship’s breadth
- Scantling draught is to be considered together with the minimum still water bending moment, selected among all homogeneous loading conditions described in the loading manual.

5.4.5 One bay empty loading conditions

One bay empty 2 (OB-2):

- cargo holds are to be loaded as per HH condition described in [5.3.5] except one bay adjacent to the fuel oil tanks to be kept empty. Fuel oil tanks are to be empty
- scantling draught is to be considered together with the maximum design still water bending moment in hogging.

One bay empty 3 (OB-3):

- cargo holds are to be loaded as per HH condition described in [5.3.5] except one bay adjacent to the fuel oil tanks to be kept empty. Fuel oil tanks are to be loaded alternately
- scantling draught is to be considered together with the maximum design still water bending moment in hogging.

One bay empty 4 (OB-4):

- cargo holds are to be loaded as per HH condition described in [5.3.5] except one bay adjacent to the fuel oil tanks to be kept empty. All fuel oil tanks are to be fully loaded
- the draught is to be taken as the lightest load draught provided in loading manual.

One bay empty 5 (OB-5):

- cargo holds are to be loaded as per HH condition described in [5.3.5] except one bay adjacent to the fuel oil tanks to be kept empty. Fuel oil tanks are to be loaded alternately
- the draught is to be taken as the lightest load draught provided in loading manual, without being taken greater than 0,75 D.

5.4.6 Testing loading conditions

Testing (TS):

- fuel oil tank testing condition is to be checked considering the test pressure as defined for deep tanks in Pt B, Ch 5, Sec 6, [10]. No dynamic pressure is to be considered. Each tank is to be filled separately
- the draught is to be taken as the minimum ballast draught from the loading manual, and the still water bending moment is to be taken from the same condition.

5.5 Load cases

5.5.1 To obtain the FE load combinations as defined in Pt B, Ch 8, App 1, [3], each loading condition is to be associated with all dynamic load cases as given in Pt B, Ch 5, Sec 2, [2] except the BP load cases.

Table 5 : Loading conditions for fuel oil tanks strength check

Loading condition	Description	Container loading (1)	FOT loading	Draught	SWBM	SWSF
BL-2	Ballast	Not loaded	Full	T_{BAL}	from LM	Q_{sw}
BL-3			Alternate			
SL-1	Maximum stack load	Heavy cargo 40'	Empty	T_{SC}	M_{sw-min}	Q_{sw}
SL-2			Alternate			
OB-2	One bay empty	Heavy cargo 40' One bay adjacent to HFO empty (2)	Empty	T_{SC}	M_{sw-max}	Q_{sw}
OB-3			Alternate			
OB-4			Full	$T_L (3)$	M_{sw-min}	
OB-5			Alternate			
TS	Testing	Not loaded	Testing	T_{BAL}	from LM	Q_{sw}

- (1) Container weights are defined in [5.2]. Each stack is to be loaded with the maximum number of tiers as defined in [5.2.1].
 (2) If the arrangement and scantling of the bays forward and aft of the FOT are symmetrical, either bay is to be empty and the other to be full. Otherwise, both conditions are to be considered.
 (3) The lightest load draught taken from the loading manual.

6 Load combinations for direct strength analysis based on full length model

6.1 Loading condition

6.1.1 A single loading condition complying with the following criteria is to be selected from the loading manual:

- the resulting draught is equal to the scantling draught, as far as practicable
- the resulting still water bending moment is at least equal to 95% of the maximum permissible still water bending moment (M_{sw-max})
- the ship is homogeneously loaded, as far as practicable
- the cargo holds are loaded up to their top, as far as practicable
- the minimum ballast water is carried.

6.1.2 The full length model is generally to be loaded with 40' containers; 20' containers might be used to fill holds that cannot be entirely filled in with 40' containers.

The selection criteria for the loading condition generally leads to a nominal container weight of 28 t / FEU (14 t / TEU). Any significant deviation to this value shall be discussed with the Society.

Note 1:

TEU : Twenty-foot Equivalent Unit, used to define a standard container of 20 feet in length

FEU : Forty-foot Equivalent Unit, used to define a standard container of 40 feet in length

6.2 Load cases

6.2.1 Load case definition

The wave heading β , in deg, which maximises each dominant load effect is specified in Tab 7.

The peak period T_p , in s, which maximises each dominant load effect is to be taken as:

$$T_p = (T_0)^{0,5} \left(\frac{2\pi L_c}{g} \right)^{0,25}$$

where:

T_0 : Wave period providing the maximum RAO, in s, to be taken as:

$$T_0 = 2,2 \left(\frac{L_c}{\alpha g} \right)^{0,5}$$

L_c : Length, in m, as defined in Pt B, Ch 5, Sec 3

α : Parameter for the considered load case, as defined in Tab 7.

6.2.2 Design value of dominant load effect

The design values of dominant load effects are specified in Tab 7.

When deemed relevant by the Society, the design values may be derived on the basis of a direct long-term linear seakeeping analysis. The long-term value for vertical bending moment is to be corrected for Froude-Krylov non-linearities. Long-term values are to be derived for a return period of 25 years, considering a North-Atlantic scatter diagram. The routing factor as defined in Pt B, Ch 5, Sec 3 is also to be considered.

6.2.3 Combined load effects

When the design value of the dominant load effect is not based on the rule value, the heading and amplitude of waves is to be selected such that the amplitude of the other combined load effects is not to exceed their rule reference value multiplied by a factor C_{max} given in Tab 6.

Table 6 : Values of factor C_{max}

Load component	C_{max}
Wave bending moments and wave torque	1,10
Wave shear forces	1,40
Roll angle, vertical and horizontal accelerations	1,10
Wave pressure	1,20

Table 7 : Load cases definition

Load case	EDW (1)	Dominant load effect	Location	Wave heading β (2)	α	Reference of design value D
1	HVM	Vertical wave bending moment M_{wv-h} or M_{wv-s}	Midship section	180°	$0,65 C_{W-LC}^{-1,3}$	M_{wv-h} and M_{wv-s} defined in [4.2.1]
2	FVM	Vertical wave bending moment M_{wv-h} or M_{wv-s}	Vicinity of 0,25L	0°	$0,65 C_{W-LC}^{-1,3}$	
3	BR	Roll motion θ	Midship section	90°	$4,60 T_R^{-2}$	θ defined in Pt B, Ch 5, Sec 3, [2.1.1]
4	BP	Wave pressure at the waterline P_w	Midship section	90°	$0,55 f_{TL}^{-0,4}$	P_w defined in Pt B, Ch 5, Sec 5, [1.3.1] for BP
5	OHM	Horizontal wave bending moment M_{wh}	Midship section	120°	$0,65 f_{TL}^{-0,3}$	M_{wh} defined in Pt B, Ch 5, Sec 4, [3.3]
6	OHS	Horizontal wave shear force Q_{wh} and torsion M_{wt}	Vicinity of 0,75L	60°	$0,68 f_{TL}^{-0,3}$	Q_{wh} defined in Pt B, Ch 5, Sec 4, [3.4] M_{wt} defined in Pt B, Ch 5, Sec 4, [3.5]
7	OVA	Vertical acceleration a_z	Vicinity of L	120°	$0,24 f_{BL}^{-0,8}$	a_z defined in Pt B, Ch 5, Sec 3, [3.2.4]

(1) Equivalent Design Wave as defined in Pt B, Ch 5, Sec 2
(2) The forward ship speed is to be taken equal to 5 knots

Note 1:
 C_{W-LC} : Waterplane coefficient at considered loading condition draught T_{LC}
 T_R : Dimensionless roll period as defined in Pt B, Ch 5, Sec 2
 f_{TL} : Ratio between draught at the considered loading condition and rule length as defined in Pt B, Ch 5, Sec 3
 f_{BL} : Ratio between moulded breadth and rule length as defined in Pt B, Ch 5, Sec 3

7 Hull girder strength assessment

7.1 Section modulus and moment of inertia

7.1.1 Minimum net moment of inertia

For both hogging and sagging conditions, the net moment of inertia I_{y-n50} , in m^4 , of the hull transverse section is to be not less than I_{y-min} , obtained from the following formula:

$$I_{y-min} = 1,55 L |M_{sw} + M_{wv}| 10^{-7}$$

7.1.2 Within the longitudinal extend as defined in Pt B, Ch 6, Sec 1, [3.2.1], the scantlings of all continuous longitudinal members are to be maintained based on the modulus requirement at the midship.

8 Cargo hold structural strength analysis

8.1 General

8.1.1 As an alternative to Pt B, Ch 8, App 1, [1.1.3], the extent of the cargo hold structural analysis may be limited to the midship area at the discretion of the Society.

9 Local structural strength analysis

9.1 Screening criteria

9.1.1 The screening criteria, as defined in Pt B, Ch 8, App 2, [1.2.3], is to be checked with a screening factor λ_{sc} and a permissible screening factor λ_{scperm} defined in Tab 8

10 Buckling

10.1 Load cases

10.1.1 HVM and FVM load cases are replaced by S11A1 and S11A2 head sea load cases, where all load components are to be applied simultaneously with the hull girder still water load values as defined in Tab 10 and the load combination factors (LCF) for the hull girder wave loads and accelerations as defined in Tab 11.

Table 8 : Screening factors and permissible screening factors

Type of details	Screening factors λ_{sc}	Permissible screening factors λ_{scperm}	
		AC-2 (1)	AC-1 (1)
Bracket toes of primary supporting members	Tab 9	1,50	1,20
Connection of stringers and double bottom girders with transverse bulkheads	$2,00 \lambda_y$	1,50	1,20
Hatch corner area	λ_y	$0,95 \lambda_{yperm}$	

(1) See Pt B, Ch 8, Sec 1, [4] for acceptance criteria definition.

Note 1:

λ_y : Standard mesh yield utilisation factor, as defined in Pt B, Ch 8, App 1, [5.2.3]

λ_{yperm} : Standard mesh permissible yield utilisation factor, as defined in Pt B, Ch 8, App 1, [5.2.3].

Table 9 : Screening factor for bracket toes of primary supporting members

λ_{sc} : Screening factor taken as:

$$\lambda_{sc} = C_a \left[0,68 \sqrt{\frac{b_2}{b_1}} \sigma_{vm} + 0,50 \sqrt{\frac{A_{beam-n50}}{b_1 t_{n50}}} \cdot |\sigma_{beam}| \right] \frac{k}{235}$$

C_a : Coefficient taken as:

$$C_a = 1,0 - 0,2 \left(\frac{R_a}{1400} \right)^2$$

b_1, b_2 : Heights of shell element in way of bracket toe in cargo hold FE model, in mm

$A_{beam-n50}$: Sectional area of beam or rod element in cargo hold FE model representing the face plate of bracket, in mm²

σ_{beam} : Beam or rod element axial stress determined from cargo hold FE analysis, in N/mm²

σ_{vm} : Von Mises stress of shell element in way of bracket toe determined from cargo hold FE analysis, in N/mm²

t_{n50} : Net thickness of shell element in way of bracket toe, in mm

R_a : Leg length, in mm, not to be taken greater than 1400 mm.

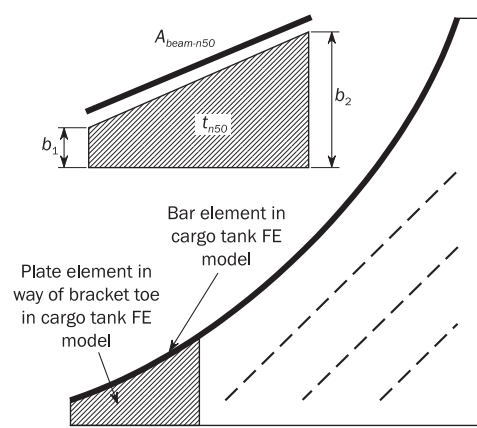
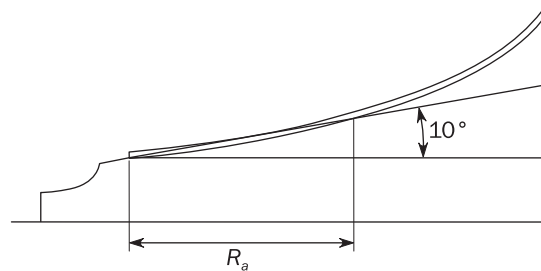



Table 10 : Hull girder still water loads for buckling strength assessment

Load component	S11A1		S11A2		
	Hogging	Sagging	Hogging	Sagging	
Hull girder still water loads	M_{sw}	M_{sw-max}	M_{sw-min}	$0,7 M_{sw-max}$	$0,7 M_{sw-min}$
	Q_{sw}	$0,7 Q_{hog}$	$0,7 Q_{sag}$	Q_{hog}	Q_{sag}
	M_{sw-t}	0	0	0	0

Note 1:

- For $x/L \leq 0,5$: $Q_{hog} = Q_{sw-max}$ and $Q_{sag} = Q_{sw-min}$
- For $x/L > 0,5$: $Q_{hog} = Q_{sw-min}$ and $Q_{sag} = Q_{sw-max}$

Table 11 : Load combination factors for buckling strength assessment

Load component		LCF	S11A1		S11A2	
			Hogging	Sagging	Hogging	Sagging
Hull girder wave loads	M_{wv}	C_{wv}	1,0	-1,0	0,7	-0,7
	Q_{wv}	C_{Qv}	$0,7 f_{lq}$	$-0,7 f_{lq}$	f_{lq}	$-f_{lq}$
	M_{wh}	C_{wh}	0	0	0	0
	Q_{wh}	C_{QH}	0	0	0	0
	M_{wt}	C_{wt}	0	0	0	0
Longitudinal accelerations	a_{surge}	C_{XS}	$10 f_{TL} - 0,60$	$0,60 - 10 f_{TL}$	$10 f_{TL} - 0,60$	$0,60 - 10 f_{TL}$
	$a_{pitch-x}$	C_{XP}	0,38	-0,38	0,38	-0,38
	a_{yaw-x}	C_{XY}	0	0	0	0
	$g \sin\phi$	C_{XG}	-0,36	0,36	-0,36	0,36
Transverse accelerations	a_{sway}	C_{YS}	0	0	0	0
	a_{roll-y}	C_{YR}	0	0	0	0
	a_{yaw-y}	C_{YY}	0	0	0	0
	$g \sin\theta$	C_{YG}	0	0	0	0
Vertical accelerations	a_{heave}	C_{ZH}	$-0,10 - 5,70 f_{TL}$	$0,10 + 5,70 f_{TL}$	$-0,10 - 5,70 f_{TL}$	$0,10 + 5,70 f_{TL}$
	a_{roll-z}	C_{ZR}	0	0	0	0
	$a_{pitch-z}$	C_{ZP}	0,38	-0,38	0,38	-0,38

Note 1:
 $f_{lq} = 1$ for $x/L \leq 0,5$ and $f_{lq} = -1$ for $x/L > 0,5$
 f_{TL} : Ratio between draught at the considered loading condition and rule length, to be taken as $f_{TL} = T_{LC} / L$
 T_{LC} : Draught amidships, in m, at the considered loading condition

11 Fatigue

11.1 Corrosion model

11.1.1 The following values of stress correction factor as defined in NI611 are to be considered:

a) for analytical approach for longitudinal stiffeners:

- $f_{c-a} = 0,95$
- $f_{c-b} = 1,0$

b) for FEA calculations:

- $f_{c-FEA} = 1,0$

11.2 Design loading condition for fatigue assessment

11.2.1 A single loading condition at $0,85 T_{SC}$ is to be considered for fatigue analysis.

When a finite element analysis is requested, the design fatigue loading condition is to be selected according to the criteria defined in [6.1], in particular with respect to the minimum value for still water bending moment, except for the resulting draught to be taken equal to $0,85 T_{SC}$. Loading conditions based on deeper draught may also be accepted.

11.2.2 For spectral fatigue analysis a second loading condition may be requested if deemed necessary. This loading condition takes into account the effect of specific local loads, typically for large fuel tanks (oil or gas).

This second loading condition is to be taken similar to the one described in [11.2.1], with only an adjustment on the local loads as necessary.

When a second loading condition is considered, the contribution to the global damage of each loading condition is to be adjusted as relevant.

12 Fixed cell guides

12.1 General

12.1.1 Containers may be secured within fixed cell guides, permanently connected by welding to the hull structure, which prevent horizontal sliding and tipping.

12.1.2 When containers are secured by fixed cell guides, the scantlings of such cell guides and supports are to comply with the criteria in [12.2] and [12.3].

12.2 Arrangement of fixed cell guides

12.2.1 Vertical guides generally consist of sections with equal sides, not less than 12 mm in thickness, extended over a height sufficient to give uniform support to containers.

12.2.2 Guides are to be connected to each other and to the supporting structures of the hull by means of cross-ties and longitudinal members such as to prevent deformation due to the action of the forces transmitted by containers.

In general, the spacing between cross-ties connecting the guides may not exceed 5 metres and their position is to coincide as nearly as possible with that of the container corners (see Fig 13).

Cross-ties are to be longitudinally restrained at one or more points so that their elastic deformation due to the action of the longitudinal thrust of containers does not exceed 20 mm at any point.

Figure 13 : Typical structure of cell guides

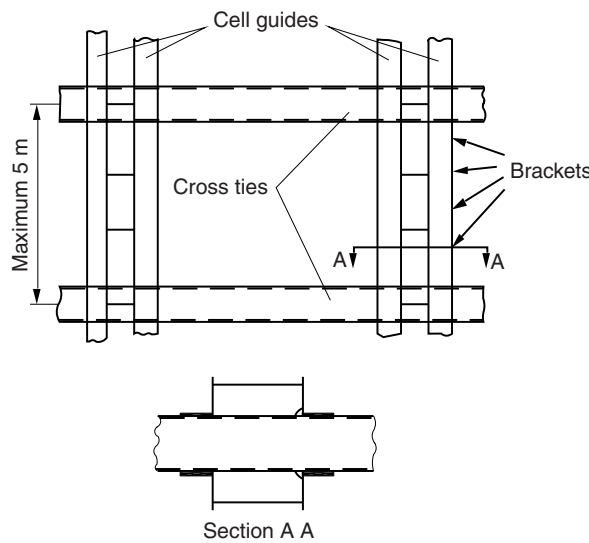

12.2.3 The upper end of the guides is to be fitted with a block to facilitate entry of the containers. Such appliance is to be of robust construction so as to withstand impact and chafing.

12.3 Strength criteria

12.3.1 The local stresses in the elements of cell guides, transverse and longitudinal cross-ties, and connections with the hull structure are to be less than the following values:

- normal stress: $150/k \text{ N/mm}^2$
- shear stress: $100/k \text{ N/mm}^2$
- Von Mises equivalent stress: $175/k \text{ N/mm}^2$,

where:

k : Material factor, defined in Pt B, Ch 4, Sec 1, [2.2].

13 Lashing bridge

13.1 General

13.1.1 Container securing

Containers on deck may be secured by means of lashing bridges permanently connected by welding to the ship structure. Lashing bridges allow lashing at a higher level.

13.1.2 Material

Materials used are to comply with Pt B, Ch 4, Sec 1. The manufacturing processes and testing are to comply with the applicable requirements of NR216 Materials and Welding.

13.1.3 Strength verification

Drawings of the lashing bridge structure and details of the supporting structure are to be submitted to the Society for approval together with details on the calculations carried out.

13.1.4 Structural modelling

Calculations are to be based at least on three-dimensional beam analysis or on finite element analysis.

A finite element model is to be used in all cases where a beam model is deemed insufficient, in particular when vertical plain bulkheads are fitted.

A finite element model is to be built in accordance with relevant requirements from Pt B, Ch 8, App 1, [2.3] and Pt B, Ch 8, App 1, [2.4].

The finite element mesh size is to be adjusted in accordance with Pt B, Ch 8, App 1, [2.4.3] in order to properly model the displacements and resulting stresses in the lashing bridge structure. At least 3 elements are to be used along the width of horizontal deck strips and vertical webs (sizes from 200 mm by 200 mm to 250 mm by 250 mm are generally adequate mesh sizes).

Adjacent ship structure is to be included in the model, vertically down to the second deck level and horizontally up to one web frame fore and aft of the transverse bulkhead.

Recommended boundary conditions are given in Tab 12.

Calculations are to be based on gross scantlings.

The connection of the lashing equipment to the lashing bridge is to be located in way of high stiffness structure. The Society may require a detailed finite element analysis in case of lashing equipment attached to a structure with limited stiffness.

Table 12 : Boundary conditions for FE model of lashing bridge

Location	Translation			Rotation		
	δ_x	δ_y	δ_z	θ_x	θ_y	θ_z
End of the model (e.g. top part of the hull, from second deck to hatch coaming)	fix	–	–	–	fix	fix
Elements linked to continuous vertical plating (e.g. linked to vertical frames of a bulkhead or to the inner hull and side shell)	–	fix	fix	–	–	–
Note 1: [–] means no constraint applied (free).						

13.1.5 Arrangement

Overall stiffness of the lashing bridge is to be sufficient to sustain the lashing loads. Stiffness reinforcement such as shear plates or diagonal bars are recommended below the level where the lashing rods can be attached.

Structural continuity is to be ensured at the connections of the vertical supports of the lashing bridge to the ship structure.

13.2 Design load

13.2.1 Forces applied on lashing bridge

The lashing bridge is to be loaded by forces corresponding to 70% of the SWL (Safe Working Load) of the container lashing equipment, taken as 250 kN.

The forces defined in Tab 13 are to be applied to lashing eyes loaded by a lashing device in maximum tension, with an assumed displacement of the stacks towards portside.

A lashing device in external or internal lashing is considered in maximum tension when the device restrains both the container racking and lifting (see Fig 14).

13.2.2 Loading conditions

The following loading conditions are to be considered for the calculation of lashing bridges:

- a) both fore and aft bays of the lashing bridge are loaded with containers
- b) fore bay of the lashing bridge is loaded with containers while the aft bay is empty
- c) aft bay of the lashing bridge is loaded with containers while the fore bay is empty.

Loading condition a) is intended to maximize vertical and transverse forces acting on the lashing bridge. Loading conditions b) and c) are intended to maximize the longitudinal forces acting on the lashing bridge.

Table 13 : Forces towards portside

Longitudinal direction	Transverse direction	Upward
20 kN (fore bay) -20 kN (aft bay)	119 kN	126 kN

Figure 14 : Loaded lashing eye

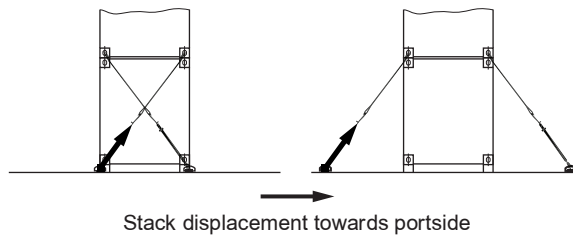

13.3 Strength assessment

13.3.1 Allowable stress

Allowable stresses for the design loads as defined in [13.2]] are to be in accordance with:

- Pt B, Ch 7, Sec 6, [5.1.4] for beam analysis
- Pt B, Ch 8, App 1, [5.2.3] or Pt B, Ch 8, App 2, [4.1.3] for finite element analysis.

13.3.2 Lashing bridge stiffness

In order to sustain the loads transmitted by the lashing devices and to have enough rigidity with limited deformations, the lashing bridge stiffness is to be assessed.

The displacement in the transverse direction at each lashing level i of the lashing bridge is to satisfy the following criteria:

$$(d_{trans,i} - d_{bot}) \leq 1,85 h_i$$

where:

- i : Lashing level depending on the vertical location of attachment of the lashing device to the lashing bridge. The level of reference (level 0) is defined as the lowest level where it is possible to attach the lashing devices over the full width of the lashing bridge (see Pt F, Ch 12, Sec 5)
- $d_{trans,i}$: Average transverse displacement, in mm, of the lashing eyes for the considered lashing level i
- d_{bot} : Average transverse displacement, in mm, of the lashing bridge at the bottom of the stack
- h_i : Average height, in m, of the lashing eyes with regard to the bottom of the stack, for the considered lashing level i

When the lashing bridge is not compliant with the above criteria, standard values for the effective stiffness factors of lashing devices as defined in Pt F, Ch 12, Sec 5, are to be replaced by values obtained with direct calculations.

14 Lashing items

14.1 Fixed cargo securing devices

14.1.1 A list and/or a plan of all the fixed securing devices, indicating their location on board, is to be provided.

14.1.2 For each type of fixed securing device, the following information is to be provided:

- identification of the device (name and model type)
- sketch of the device and material quality
- value of Safe Working Load (also named Maximum Securing Load)
- value of the minimum breaking load.

14.1.3 The deck stanchions are to be checked according to the criteria for pillars defined in Pt B, Ch 7, Sec 6, [2.6] with design loads submitted by the manufacturer.

14.2 Lashing software

14.2.1 If installed on board a ship, a lashing software is to be approved, following the provisions of Pt F, Ch 12, Sec 5.

Section 3 Machinery and Systems

1 Open-top container ships

1.1

1.1.1 Open-top container ships are to comply with the requirements of Pt F, Ch 12, Sec 6.

Part D

Service Notations

CHAPTER 3

LIVESTOCK CARRIERS

- Section 1 General
- Section 2 Hull and Stability
- Section 3 Systems Serving Livestock Spaces
- Section 4 Fire-Fighting Systems in Livestock Spaces

Section 1 General

1 General

1.1 Application

1.1.1 Ships complying with the requirements of this Chapter are eligible for the assignment of the service notation **livestock carrier**, as defined in Pt A, Ch 1, Sec 2, [4.2.6].

1.1.2 Ships dealt with in this Chapter are to comply with:

- Part A of the Rules
- NR216 Materials and Welding
- applicable requirements according to Tab 1.

1.2 Summary table

1.2.1 Requirements applicable to ships having the service notation **livestock carrier** are summarized in Tab 1.

Table 1 : Applicable requirements

Item		Greater than or equal to 500 GT	Less than 500 GT
Ship arrangement	L ≥ 65 or 90 m (1)	<ul style="list-style-type: none"> • Part B • Ch 3, Sec 2 	<ul style="list-style-type: none"> • NR566 • Ch 3, Sec 2
	L < 65 or 90 m (1)	<ul style="list-style-type: none"> • NR600 	<ul style="list-style-type: none"> • NR566 • Ch 3, Sec 2
Hull	L ≥ 65 or 90 m (1)	<ul style="list-style-type: none"> • Part B • Ch 3, Sec 2 	<ul style="list-style-type: none"> • Part B • Ch 3, Sec 2
	L < 65 or 90 m (1)	<ul style="list-style-type: none"> • NR600 	<ul style="list-style-type: none"> • NR600
Stability		<ul style="list-style-type: none"> • Part B • Ch 3, Sec 2 	<ul style="list-style-type: none"> • NR566 • Ch 3, Sec 2
Machinery and cargo systems		<ul style="list-style-type: none"> • Part C • Ch 3, Sec 3 	<ul style="list-style-type: none"> • NR566 • Ch 3, Sec 3
Electrical installations		<ul style="list-style-type: none"> • Part C 	<ul style="list-style-type: none"> • NR566
Automation		<ul style="list-style-type: none"> • Part C 	<ul style="list-style-type: none"> • NR566
Fire protection, detection and extinction		<ul style="list-style-type: none"> • Part C • Ch 3, Sec 4 	<ul style="list-style-type: none"> • NR566 • Ch 3, Sec 4
<p>(1) Refer to the scope of application of NR600.</p> <p>Note 1: NR566: Hull Arrangement, Stability and Systems for Ships less than 500 GT. NR600: Hull Structure and Arrangement for the Classification of Cargo Ships less than 65 m and Non Cargo Ships less than 90 m.</p>			

Section 2 Hull and Stability

1 General

1.1 Documents to be submitted

1.1.1 In addition to the documentation requested in Part B, the following documents are to be submitted for information:

- livestock arrangement
- distribution of fodder and consumable liquid on the various decks and platforms.

2 General arrangement

2.1 Livestock arrangement

2.1.1 The livestock are to be kept in pens. The dimensions of these pens are to be suitable for the livestock carried. In general, the breadth and the length of the pen may not be greater than 4,5 m and 9 m, respectively.

The livestock may not be carried on hatch covers unless the latter are effectively protected.

2.2 Arrangement of spaces dedicated to the carriage of livestock

2.2.1 General

The requirements of this item apply to the arrangement of the spaces dedicated to the carriage of livestock. When deemed necessary by the Society, such spaces may need to be adapted or complemented depending on the species of animals which are to be carried.

2.2.2 Protection of livestock

Arrangements for protecting the livestock from injury, avoidable suffering and exposure to weather, sea or hot parts are to be provided.

2.2.3 Livestock arrangement

Livestock may not be carried, or loaded for carriage, in any part of a ship where the livestock, livestock fittings, livestock equipment or carrying arrangements may:

- obstruct access to any accommodation space or working space necessary for the safe running of the ship, or the means of egress from any hold or under deck space
- interfere with life-saving or fire-fighting appliances
- interfere with the tank sounding equipment or bilge pumping
- interfere with the operation of closing appliances
- interfere with the operation of freeing ports
- interfere with the lighting or ventilation of other parts of the ships
- interfere with the proper navigation of the ship.

2.3 Means of escape and access

2.3.1 General

In each space in which livestock is carried, not less than two means of escape for persons are to be fitted, widely separated and giving access to an open deck.

Access to livestock space for persons is to be safe. Where it is combined with a ramp used for moving livestock between decks, it is to be separated from the livestock ramp by protective fencing.

2.3.2 Closing arrangement

Pens, stalls and similar fittings are to be provided with a means of access for persons with secure closing arrangement which structural strength is to be considered by the Society on a case-by-case basis.

2.3.3 Passageway width

If access between a ship side and a pen, stall or similar fitting is required for purposes of safe and proper operation of ship, a passageway not less than 550 mm wide is to be provided between the ship's rail or bulwark and the rails or receptacles of the pen, stall or fitting.

3 Stability

3.1 Intact stability

3.1.1 General

The stability of the ship for the loading conditions reported in the trim and stability booklet is to be in compliance with the requirements of Pt B, Ch 3, Sec 2.

3.1.2 Additional requirements

Where national or international rules apply, the Society reserves the right to adopt the rules in force in the country in which the ship is registered or in which the ship trades.

4 Design loads

4.1 Local loads

4.1.1 Cargo deck

The static pressure P_{dl-s} , in kN/m², due to livestock on decks to be considered for the assessment of plating and stiffeners is to be defined by the Designer.

When no value is specified, the following may be considered:

- 15 kN/m² for cattle, horses and camels
- 8 kN/m² for sheep, goats and pigs.

For the assessment of primary supporting members, P_{dl-s} is to be taken equal to 0,3 times the value defined above for plating and stiffeners.

4.2 Load combinations for direct strength analysis

4.2.1 Loading condition

One loading condition is to be selected among those presented in the loading manual considering the following criteria:

- it represents the maximum draught
- it results in the highest vertical bending moment.

4.2.2 Load cases

The loading condition defined in [4.2.1] is to be associated to the following dynamic load cases:

- HVM
- FVM
- OVA1
- BP2
- OHM
- OHS
- BR1

5 Hull girder strength

5.1 Application

5.1.1 Strength deck

In addition to the requirements in Pt B, Ch 6, Sec 1, [1.3], the contribution of the hull structures up to the strength deck to the longitudinal strength is to be assessed through a finite element analysis of the whole ship in the following cases:

- when the size of openings in the side shell and/or longitudinal bulkheads located below the deck assumed by the Designer as the strength deck decrease significantly the capability of the plating to transmit shear forces to the strength deck.
- when the ends of superstructures which are required to contribute to longitudinal strength may be considered not effectively connected to the hull structures in way.

Alternatively, finite element analysis may be replaced by beam analysis on a case-by-case basis.

5.2 Global transverse strength

5.2.1 The behaviour of the ship primary structural members under racking effects due to transverse forces induced by transverse accelerations is to be investigated according to Pt B, Ch 7, App 1, or by means of a complete ship model according to Pt B, Ch 8, App 3.

6 Hull scantlings

6.1 Scantlings of plating, ordinary stiffeners and primary supporting members

6.1.1 Movable or collapsible structural elements above the strength deck

In general, the movable or collapsible structural elements used for the stocking and the distribution of livestock on decks or platform decks are not considered for classification purpose.

Nevertheless, where deemed necessary by the shipyard they may be designed and constructed according to the criteria in Part B, Chapter 7. In this case, the scantlings of the barriers surrounding each pen are to take into account the loads applied by the livestock as a result of roll and pitch of the ship.

Section 3 Systems serving Livestock Spaces

1 General

1.1 Application

1.1.1 The provisions of this Section cover the systems installed on ships having the service notation **livestock carrier** and intended for:

- the supply of food, water and fresh air to the livestock
- the cleaning of the livestock spaces
- the draining of the sewage effluents produced by the livestock.

1.2 Documents to be submitted

1.2.1 The documents listed in Tab 1 are to be submitted for approval.

Table 1 : Documents to be submitted

Item No.	Description of the document (1)
1	Diagram of the ventilation system, with indication of the gross volume of the enclosed spaces
2	Diagram of storage and distribution systems for fodder and water
3	Diagram of the water cleaning system
4	Diagram of the drainage system
(1) Diagrams are also to include, where applicable: <ul style="list-style-type: none"> • the (local and remote) control and monitoring systems and automation systems • the instructions for the operation and maintenance of the piping system concerned (for information). 	

2 Design of the systems

2.1 General

2.1.1 The piping systems covered by this Section are to be designed, constructed and tested in accordance with the applicable provisions of Pt C, Ch 1, Sec 10.

2.2 Ventilation system

2.2.1 General

Mechanical ventilation is to be provided for the following spaces containing livestock:

- enclosed spaces
- partially closed spaces arranged with pens on more than one deck level and having a breadth greater than 20 m.

2.2.2 Capacity of the mechanical ventilation

The capacity of the mechanical ventilation is not to be less than:

- 20 air changes per hour of each enclosed space
- 15 air changes per hour of each partially closed space,

based on the gross volume of the space, deduced, if possible, from the volume of any tank or trunk within that space.

Note 1: Where the clear height of the space is less than 2,30 m, the Society may require higher air change rates, with a maximum of:

- 30 changes per hour for enclosed spaces
- 22,5 changes per hour for partially closed spaces.

2.2.3 Fans

- a) Ventilation circuits are to be supplied by at least two independent fans of such a capacity as to maintain normal ventilation of all the spaces with one fan out of action.
- b) Fans driven by electric motors are to be considered as essential auxiliaries. Their electrical supply is to comply with the provisions of Pt C, Ch 2, Sec 3.

2.3 Fodder and fresh water systems

2.3.1 General

- a) Spaces intended for livestock are to be provided with receptacles for feeding and watering the animals concerned.
- b) The capacity of the receptacles is not to be less than 33% of the daily consumption of the animals concerned, except when the feed system is automatic.

2.3.2 Fresh water system

- a) The fresh water system serving the livestock spaces is to be totally independent from the fresh water system serving the spaces intended for the crew.
- b) All livestock spaces are to be provided with fresh water service.
- c) The fresh water system is to include at least:
 - one main supply pump, of a capacity sufficient to continuously supply fresh water to the livestock
 - one standby pump of at least the same capacity.

Note 1: When the water supply system is not automatic, the standby pump may be replaced by a portable pump ready to be connected to at least one fresh water tank.

- d) When the water supply is automatic, water receptacles are to be fitted with:
 - means of automatic water level control
 - devices to avoid the return of water from the receptacle to the fresh water tank.

2.4 Washing system

2.4.1 A water washing system is to be provided with appropriate connections to wash the livestock spaces.

2.5 Drainage system

2.5.1 General

- a) Each space intended for the livestock is to be fitted with a pipe or gutter of sufficient size to drain the sewage and the washing effluents.
- b) The drainage system serving the livestock spaces is to be independent from any piping system serving the other spaces of the ship, and in particular from the bilge system.

2.5.2 Materials

The pipes and other components of the draining system are to be made of a material resistant to the corrosion due to the effluents.

2.5.3 Draining pipes and discharges

- a) Discharges from livestock spaces are to comply with the provisions of Pt C, Ch 1, Sec 10, [8].
- b) Where necessary, drainage gutters and upper parts of the draining pipes are to be covered by a strainer plate.
- c) Draining pipes from livestock spaces are to discharge into a holding tank, wells or overboard.

Note 1: Overboard discharge is subject to the provisions of MARPOL Annex IV - Regulations for the Prevention of Pollution by Sewage.

- d) Means are to be provided to stop the overboard discharge when the ship is in port.

2.5.4 Drainage tanks

- a) Drainage tanks are to be fitted with means to indicate visually the amount of their content.
- b) Drainage tanks and wells are to be accessible from outside livestock pens for inspection and cleaning.

2.5.5 Pumps and ejectors

Pumps and ejectors serving the drainage tanks or wells are to be capable of conveying semi-solid matter.

2.6 Lighting system

2.6.1 Permanently fixed adequate lighting is to be provided to give a sufficient level of illumination in passage ways between pens and access routes between or from those parts.

2.6.2 An emergency permanently fixed lighting system is to be provided in case of failure of the main electrical system required in [2.6.1]. This lighting system is to comply with the requirements in Part C, Chapter 2 for emergency lighting.

2.6.3 In addition to those required in [2.6.1], fixed or portable lightings are to be provided to give a sufficient level of illumination so that livestock can be inspected in each pen.

Section 4 Fire-Fighting Systems in Livestock Spaces

1 General

1.1 Application

1.1.1 This Section provides, for ships having the service notation **livestock carrier**, specific requirements for fire-fighting in the livestock spaces.

Such requirements supplement those given in Part C, Chapter 4.

1.2 Documents to be submitted

1.2.1 The documents listed in Tab 1 are to be submitted for approval.

Table 1 : Documents to be submitted

No.	Description of the document
1	Drawing showing the location of the fire-fighting appliances fitted in the livestock spaces
2	Specification of the fire-fighting appliances

2 Fire-fighting appliances

2.1 Fire hoses

2.1.1 The number and position of the hydrants are to be such that at least two jets of water not emanating from the same hydrant may reach any part of the spaces intended for the livestock. At least one of these jets is to be from a single length of hose.

2.1.2 Fire hoses are to be provided for:

- each hydrant located in an enclosed space, and
- for each 50 m length, or part thereof, of open deck spaces.

2.1.3 Fire hoses are to be located in conspicuous locations, near the hydrants and close to the entrances or access to the spaces.

2.2 Additional fire-fighting means

2.2.1 Livestock spaces containing hay or straw

If hay or straw is carried or used in a livestock space, one of the following fire-fighting means is to be provided:

- a fixed water fire-fighting system, or
- portable water extinguishers spaced no more than 18 m apart, one of these extinguishers being positioned at the entrance of the space concerned.

2.2.2 Livestock spaces containing electrical equipment other than lighting systems

If electrical equipment other than that referred to in Ch 3, Sec 3, [2.6] is located in an enclosed livestock space, suitable fire-fighting means are to be provided in this respect.

Part D

Service Notations

CHAPTER 4

BULK CARRIERS

Section 1	General
Section 2	Ship Arrangement
Section 3	Hull and Stability
Appendix 1	Intact Stability Criteria for Grain Loading
Appendix 2	Hold Mass Curves

Section 1 General

1 General

1.1 Application

1.1.1 Ships complying with the requirements of this Chapter are eligible for the assignment of one of the service notations:

- **bulk carrier ESP, bulk carrier CSR ESP, bulk carrier CSR BC-A ESP, bulk carrier CSR BC-B ESP or bulk carrier CSR BC-C ESP**, as defined in Pt A, Ch 1, Sec 2, [4.3.2]
- **Self-unloading bulk carrier ESP**, as defined in Pt A, Ch 1, Sec 2, [4.3.6]
- **bulk carrier**, as defined in Pt A, Ch 1, Sec 2, [4.3.1].

1.1.2 Ships dealt with in this Chapter are to comply with:

- Part A of the Rules
- NR216 Materials and Welding
- applicable requirements according to Tab 1.

Table 1 : Applicable requirements

Item		Ships having the additional service feature CSR	Ships not having the additional service feature CSR	
			Greater than or equal to 500 GT	Less than 500 GT
Ship arrangement	$L \geq 90$	<ul style="list-style-type: none"> • NR606 • Ch 4, Sec 2, [2] 	<ul style="list-style-type: none"> • Part B • Ch 4, Sec 2 	<ul style="list-style-type: none"> • NR566 • Ch 4, Sec 2
	$65 \leq L < 90$	N.A.	<ul style="list-style-type: none"> • Part B • Ch 4, Sec 2 	<ul style="list-style-type: none"> • NR566 • Ch 4, Sec 2
	$L < 65$	N.A.	<ul style="list-style-type: none"> • NR600 	<ul style="list-style-type: none"> • NR566 • Ch 4, Sec 2
Hull	$L \geq 90$	<ul style="list-style-type: none"> • NR606 (1) 	<ul style="list-style-type: none"> • Part B • Ch 4, Sec 3 	<ul style="list-style-type: none"> • Part B • Ch 4, Sec 3
	$L \geq 65$	N.A.	<ul style="list-style-type: none"> • Part B • Ch 4, Sec 3 	<ul style="list-style-type: none"> • Part B • Ch 4, Sec 3
	$L < 65$	N.A.	<ul style="list-style-type: none"> • NR600 	<ul style="list-style-type: none"> • NR600
Stability		<ul style="list-style-type: none"> • Part B • Ch 4, Sec 3, [1] 	<ul style="list-style-type: none"> • Part B • Ch 4, Sec 3, [1] 	<ul style="list-style-type: none"> • NR566 • Ch 4, Sec 3, [1]
Machinery and cargo systems		Part C	Part C	NR566
Electrical installations		Part C	Part C	NR566
Automation		Part C	Part C	NR566
Fire protection, detection and extinction		Part C	Part C	NR566
<p>(1) IACS Recommendation No.167 "Guidelines for the Identification of Vibration Issues and Recommended Remedial Measures on Ships" is to be applied on ships assigned additional service feature CSR.</p> <p>Note 1: NR566: Hull Arrangement, Stability and Systems for Ships less than 500 GT. NR600: Hull Structure and Arrangement for the Classification of Cargo Ships less than 65 m and Non Cargo Ships less than 90 m. NR606: Common Structural Rules for Bulk Carriers and Oil Tankers.</p>				

Section 2 Ship Arrangement

1 General arrangement design

1.1 General

1.1.1 Forecastle

Ships with the service notation **bulk carrier ESP** or **bulk carrier** are to be fitted with an enclosed forecastle on the freeboard deck, with its aft bulkhead fitted in way or aft of the forward bulkhead of the foremost hold, as shown in Fig 1.

However, if this requirement hinders hatch cover operation, the aft bulkhead of the forecastle may be fitted forward of the forward bulkhead of the foremost cargo hold provided the forecastle length is not less than 7% of ship length abaft the forward perpendicular where the ship length and forward perpendicular are defined in the International Convention on Load Lines 1966 and its Protocol 1988.

The forecastle height H_F above the main deck is to be not less than:

- the standard height of a superstructure as specified in Pt B, Ch 1, Sec 3, [2.2]
- $H_C + 0,5$ m, where H_C is the height of the forward transverse hatch coming of the foremost cargo hold, i.e. cargo hold No. 1, whichever is the greater.

All points of the aft edge of the forecastle deck are to be located at a distance l_F :

$$l_F \leq 5\sqrt{H_F - H_C}$$

from the hatch coming plate in order to apply the reduced loading to the No. 1 forward transverse hatch coaming and No. 1 hatch cover in applying Pt B, Ch 11, Sec 9, [4.1.3], and Pt B, Ch 11, Sec 9, [8.3.9].

A breakwater is not to be fitted on the forecastle deck with the purpose of protecting the hatch coaming or hatch covers. If fitted for other purposes, it is to be located such that its upper edge at centre line is not less than $H_B / \tan 20^\circ$ forward of the aft edge of the forecastle deck, where H_B is the height of the breakwater above the forecastle (see Fig 1).

Figure 1 : Forecastle arrangement

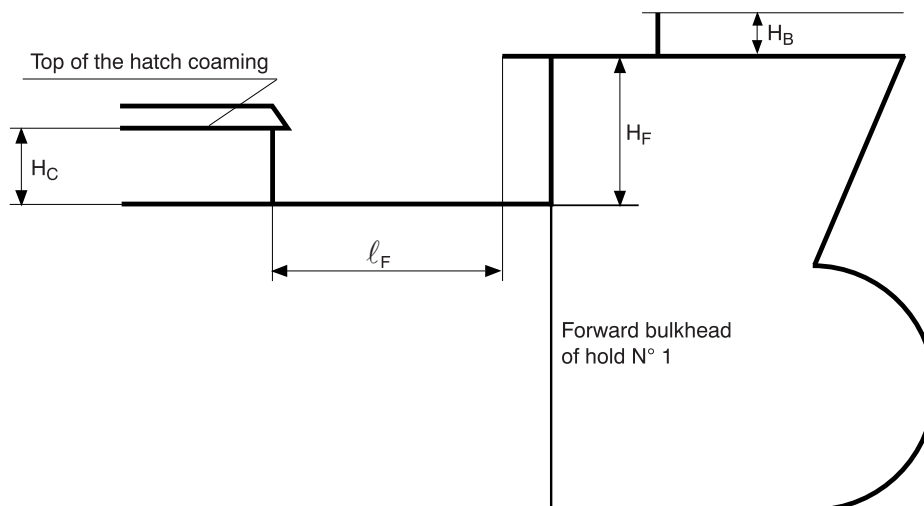

2 Access arrangement

2.1 Access arrangement to double bottom and pipe tunnel

2.1.1 Means of access

Adequate means of access to the double bottom and the pipe tunnel are to be provided.

2.1.2 Manholes in the inner bottom, floors and girders

Manholes cut in the inner bottom are to be located at a minimum distance of one floor spacing from the lower stool, or transverse bulkhead if no stool is fitted.

The location and size of manholes in floors and girders are to be determined to facilitate the access to double bottom structures and their ventilation. However, they are to be avoided in the areas where high shear stresses may occur.

2.2 Access arrangement to and within spaces in, and forward of, the cargo area

2.2.1 Means of access

Ships with the service notation **bulk carrier CSR ESP**, **bulk carrier CSR BC-A ESP**, **bulk carrier CSR BC-B ESP**, **bulk carrier CSR BC-C ESP**, are to comply with the relevant requirements of NR606 Common structural rules for bulk carriers and oil tankers.

Ships with the service notation **bulk carrier ESP** or **bulk carrier** of less than 150 m in length and of 20,000 gross tonnage and over, are to comply with SOLAS, Ch II-1, Reg 3-6.

Ships with the service notation **bulk carrier ESP** or **bulk carrier** are to comply with [2.2.2] and [2.2.3]. In addition, as far as practicable, permanent or movable means of access stored on board are to be provided to ensure proper survey and maintenance of cargo holds and, in particular, of the lower part of cargo hold side frames.

2.2.2 Hatches of cargo holds

If separate hatches are used as access to the ladders as required in [2.2.3], each hatch is to have a clear opening of at least 600 mm x 600 mm.

When the access to the cargo hold is arranged through the cargo hatch, the top of the ladder is to be placed as close as possible to the hatch coaming.

Accesses and ladders are to be so arranged that personnel equipped with self-contained breathing apparatus may readily enter and leave the cargo hold.

Access hatch coamings having a height greater than 900 mm are also to have steps on the outside in conjunction with cargo hold ladders.

2.2.3 Ladders within cargo holds

Each cargo hold is to be provided with at least two ladders as far apart as practicable longitudinally. If possible these ladders are to be arranged diagonally, e.g. one ladder near the forward bulkhead on the port side, the other one near the aft bulkhead on the starboard side, from the ship's centreline.

Ladders are to be so designed and arranged that the risk of damage from the cargo handling gear is minimised.

Vertical ladders may be permitted provided they are arranged above each other in line with other ladders to which they form access and resting positions are provided at not more than 9 metres apart.

Tunnels passing through cargo holds are to be equipped with ladders or steps at each end of the hold so that personnel may get across such tunnels.

Where it may be necessary for work to be carried out within a cargo hold preparatory to loading, consideration is to be given to suitable arrangements for the safe handling of portable staging or movable platforms.

Section 3 Hull and Stability

Symbols

- D_p : Propeller diameter, in m
 L_{LL} : Load line length, in m, defined in Pt B, Ch 1, Sec 3, [2.1.2]
 ℓ : Span, in m, of side frames; see [2.2.2]
 M_{Full}, M_H, M_{HD} : Cargo mass, in t, in a cargo hold, as defined in Pt B, Ch 5, Sec 6
 t_c : Corrosion addition, in mm, defined in Pt B, Ch 4, Sec 2, [1.1.1]
 ℓ_p : Distance from propeller centreline to the waterline, in m.
 P : Design pressure in kN/m^2 , for the design load set being considered according to Pt B, Ch 7, Sec 2, [2] and calculated at the load calculation point defined in Pt B, Ch 4, Sec 6, [3.2].

1 Stability

1.1 Definitions

1.1.1 Grain

The term grain covers wheat, maize (corn), oats, rye, barley, rice, pulses, seeds and processed forms thereof, whose behaviour is similar to that of grain in its natural state.

1.1.2 Filled compartment trimmed

The term filled compartment trimmed refers to any cargo space in which, after loading and trimming as specified in Ch 4, App 1, the bulk grain is at its highest possible level.

1.1.3 Filled compartment untrimmed

The term filled compartment untrimmed refers to a cargo space which is filled to the maximum extent possible in way of the hatch opening but which has not been trimmed outside the periphery of the hatch opening.

1.1.4 Partially filled compartment

The term partly filled compartment refers to any cargo space where the bulk grain is not loaded in the manner prescribed in [1.1.2] or [1.1.3].

1.1.5 Stowage factor

The term stowage factor, for the purposes of calculating the grain heeling moment caused by a shift of grain, means the volume per unit weight of the cargo as attested by the loading facility, i.e. no allowance is to be made for lost space when the cargo space is nominally filled.

1.1.6 Specially suitable compartment

The term specially suitable compartment refers to a cargo space which is constructed with at least two vertical or sloping, longitudinal, grain-tight divisions which are coincident with the hatch side girders or are so positioned as to limit the effect of any transverse shift of grain. If sloping, the divisions are to have an inclination of not less than 30° to the horizontal.

1.2 Intact stability

1.2.1 General

The stability of the ship for the loading conditions in Pt B, Ch 3, App 2, [1.2.5] is to be in compliance with the requirements of Pt B, Ch 3, Sec 2. In addition, the requirements in [1.2.2] and [1.2.3] are to be complied with.

1.2.2 Grain Loading Manual

Information in printed booklet form is to be provided on board to enable the Master to ensure that the ship complies with the stability requirements reported in the Rules when carrying grain in bulk. This booklet is commonly referred to as Grain Loading Manual and is to include the following information:

- ship's particulars
- lightship displacement and the vertical distance from the intersection of the moulded base line and midship section to the centre of gravity (KG)
- table of liquid free surface corrections
- capacities and centres of gravity
- curve or table of angle of flooding, where less than 40°, at all permissible displacements
- curves or tables of hydrostatic properties suitable for the range of operating drafts
- cross curves of stability which are sufficient for the purpose of the requirements in [1.2.3] and which include curves at 12° and 40°
- curves or tables of volumes, vertical centres of volumes, and assumed volumetric heeling moments for every hold, filled or partly filled, or combination thereof, including the effects of temporary fittings
- tables or curves of maximum permissible heeling moments for varying displacements and varying vertical centres of gravity to allow the Master to demonstrate compliance with the requirements specified in [1.2.3]
- loading instructions in the form of notes summarising the requirements of these Rules
- a worked example for the guidance of the Master
- typical loaded service departure and arrival conditions and, where necessary, intermediate worst service conditions.

It is recommended that loading conditions should be provided for at least three representative stowage factors.

The Grain Loading Manual may be drawn up in the official language or languages of the Administration of the issuing country; if the language used is neither English nor French, the text is to include a translation into one of these languages.

1.2.3 Intact stability criteria for grain loading

The intact stability characteristics of any ship carrying bulk grain are to be shown to meet, throughout the voyage, at least the following criteria after taking into account in the manner described in Ch 4, App 1 and in Fig 1, the heeling moments due to grain shift:

- the angle of heel due to the shift of grain is to be not greater than 12° or the angle at which the deck edge is immersed, whichever is the lesser
- in the statical stability diagram, the net or residual area between the heeling arm curve and the righting arm curve up to the angle of heel of maximum difference between the ordinates of the two curves, or 40° or the angle of flooding, whichever is the least, is in all conditions of loading to be not less than 0,075 m·rad
- the initial metacentric height, after correction for the free surface effects of liquids in tanks, as specified in Pt B, Ch 3, Sec 2, [4], is to be not less than 0,30 m.

After loading, the Master is to ensure that the ship is upright before proceeding to sea.

Figure 1 : Stability curve

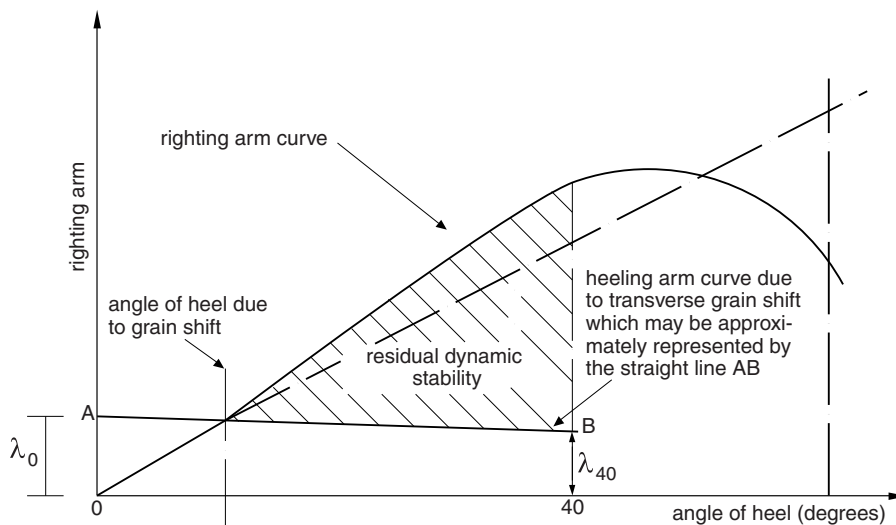

1.3 Damage stability requirements for ships where additional class notation SDS is required

1.3.1 General

Ships with the service notation **bulk carrier ESP**, **bulk carrier CSR ESP**, **bulk carrier CSR BC-A ESP**, **bulk carrier CSR BC-B ESP**, **bulk carrier CSR BC-C ESP** or **bulk carrier** where additional class notation **SDS** is required (see Pt A, Ch 1, Sec 2, [6.17.1]), equal to or greater than 80 m in length, are subjected to the probabilistic approach reported in Pt B, Ch 3, Sec 3, [2.1.3] and are to comply with the requirements in Pt B, Ch 3, App 3.

1.3.2 Freeboard reduction

Ships with the service notation **bulk carrier CSR ESP**, **bulk carrier CSR BC-A ESP**, **bulk carrier CSR BC-B ESP**, **bulk carrier CSR BC-C ESP** or **bulk carrier** greater than 100 m in length which have been assigned reduced freeboard as permitted by Regulation 27 of the International Convention on Load Lines, 1966, as referenced in Pt B, Ch 3, Sec 3, [2.1.2] are to comply with the requirements specified in Pt B, Ch 3, App 4. Therefore, compliance with the requirements in [1.3.1] is not required.

1.3.3 Additional requirements for single side skin bulk carriers equal to or greater than 150 m in length

The requirements specified in [1.3.4] to [1.3.6] apply to single side skin bulk carriers, where additional class notation **SDS** is required, equal to or greater than 150 m in length, intended for the carriage of bulk cargoes having dry bulk density of 1.0 t/m³, or above.

Ships complying with the requirements in [1.3.2] are not required to comply with those in [1.3.4] to [1.3.6].

1.3.4 Flooding of cargo holds

Bulk carriers specified in [1.3.3], when loaded to the summer load line, are to be able to withstand flooding of any one cargo hold in all loading conditions and remain afloat in satisfactory condition as specified in [1.3.5].

1.3.5 Flooding criteria

After flooding, the vessel is to comply with the requirements laid down in Pt B, Ch 3, App 4.

The assumed flooding need only take into account flooding of the cargo hold space, considering the permeability values specified in [1.3.6].

1.3.6 Flooding assumptions

The permeability of a loaded hold is to be assumed as 0,9, unless a permeability relevant to a particular cargo is assumed for the volume of a flooded hold occupied by cargo and a permeability of 0,95 is assumed for the remaining empty volume of the hold. In the latter case, the permeabilities and the corresponding cargo densities specified in [3.2.2] are to be assumed.

The permeability of an empty hold is to be assumed as 0,95.

2 Structure design principles

2.1 Double bottom structure

2.1.1 Longitudinally framed double bottom

In ships greater than 120 m in length, the double bottom and the sloped bulkheads of hopper tanks are to be longitudinally framed.

The girder spacing is to be not greater than 4 times the spacing of bottom or inner bottom ordinary stiffeners and the floor spacing is to be not greater than 3 frame spaces.

Greater spacing may be accepted by the Society, depending on the results of the analysis carried out according to Part B, Chapter 8 for the primary supporting members in the cargo holds.

2.1.2 Transversely framed double bottom

The double bottom and the sloped bulkheads of hopper tanks may be transversely framed in ships equal to or less than 120 m in length, when this is deemed acceptable by the Society on a case-by-case basis. In this case, however, the floor spacing is to be not greater than 2 frame spaces.

2.1.3 Floors in way of transverse bulkheads

The thickness and material properties of the supporting floors and pipe tunnel beams are to be not less than those required for the bulkhead plating or, when a stool is fitted, of the stool side plating.

2.2 Single side structure

2.2.1 Frame spacing

In general, the frame spacing in cargo holds bounded by the side shell only is to be not greater than the values obtained, in m, from the following formulae:

$$s = 0,6 + \frac{L}{320} \quad \text{for } L < 90\text{m}$$

$$s = 0,9 + 1,25 \left(\frac{L}{100} \right)^{0,25} \quad \text{for } L \geq 90\text{m}$$

2.2.2 Frame span and web height

Frame span ℓ and web height d are to be measured as indicated in Fig 2.

2.2.3 Symmetrical frame sections

Frames are to be fabricated symmetrical sections with integral upper and lower brackets and are to be arranged with soft toes.

The web depth to thickness ratio is to be not greater than $60 k^{0.5}$. The outstanding flange is to be not greater than $10 k^{0.5}$ times the flange thickness. The end of the flange is to be sniped.

The frame flange is to be curved (not knuckled) at the connection with the end brackets. The radius of curvature (see Fig 2) is to be not less than the value obtained, in mm, from the following formula:

$$r = \frac{0,4b_f^2}{t_f}$$

where b_f and t_f are, in mm, the flange width and thickness, respectively.

2.2.4 Asymmetrical frame sections

In ships less than 190 m in length, mild steel frames may be asymmetrical and fitted with overlapped welded brackets. The face plate or flange of the bracket is to be sniped at both ends. Brackets are to be arranged with soft toes.

The web to thickness ratio is to be not greater than $50 k^{0.5}$. The outstanding flange is to be not greater than $10 k^{0.5}$ times the flange thickness.

2.2.5 Lower and upper end brackets

The section modulus of the frame end bracket or integral bracket, calculated, with an attached side plating according to Pt B, Ch 4, Sec 6, [1.3], at the end sections of the span ℓ (sections AA and BB in Fig 2), is to be not less than twice the section modulus required for the frame midspan area according to Pt B, Ch 7, Sec 6 or NR600, as applicable.

The dimensions of the lower and upper end brackets are to be not less than those shown in Fig 2.

Figure 2 : Frame and end bracket geometry

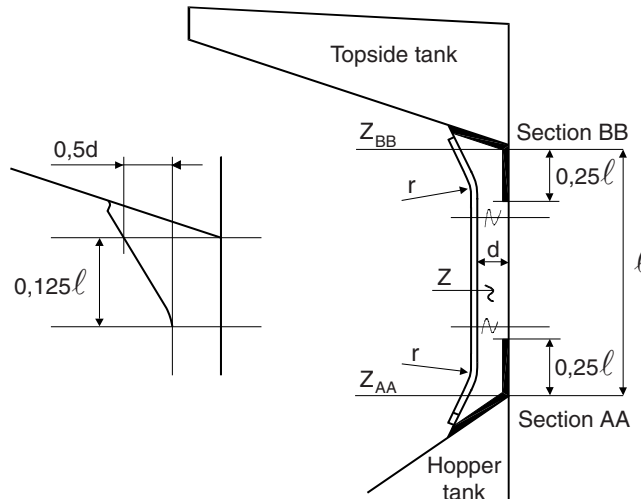

2.2.6 Connecting brackets within hopper and topside tanks

Structural continuity with the upper and lower end connections of side frames is to be ensured within hopper and topside tanks by connecting brackets as shown in Fig 3.

The net connection area of the lower or upper connecting bracket to the supporting longitudinal stiffener is to comply with the following formula:

$$\sum_i A_i d_i R_{eH, bkt-i} \geq 0,02 \alpha_T P S \ell_{SF}^2 10^{-3}$$

The net section modulus of the:

- Side shell and hopper tank longitudinals supporting the lower connecting brackets.
- Side shell and topside tank longitudinals supporting the upper connecting brackets.

is to comply with the following formula:

$$\sum_{i=1}^n Z_{pli} d_i \geq \alpha_T \frac{P \ell_{SF}^2 \ell_1^2}{16 R_{eH}}$$

where:

- A_i : The offered net connection area of the bracket connecting with the i-th longitudinal stiffener, in cm².
- d_i : Distance, in m, of the above i-th longitudinal stiffener from the intersection point of the side shell and hopper/topside tank.
- ℓ_1 : Spacing, in m, of transverse supporting webs in hopper/topside tank, as applicable.
- ℓ_{SF} : Side frame span, in m, not to be taken less than 0,25 D.
- n : Number of the longitudinal stiffeners on the side shell and hopper/topside tank supporting the lower/upper end connecting bracket of the side frame, as applicable.
- R_{eH} : Lowest value of specified yield stress, in N/mm², among the materials of the longitudinal stiffeners of side shell and hopper/topside tanks that support the lower/upper end connecting bracket of the side frame.
- $R_{eH,bkt-i}$: The specified minimum yield stress of the bracket connecting with the i-th longitudinal stiffener, in N/mm².
- Z_{pli} : Net plastic section modulus, in cm³, of the i-th longitudinal stiffener on the side shell or hopper/topside tank supporting the lower/upper end connecting bracket of the side frame, as applicable.
- α_T : Coefficient taken as:
 - $\alpha_T = 150$ for the longitudinal stiffeners supporting the lower connecting brackets.
 - $\alpha_T = 75$ for the longitudinal stiffeners supporting the upper connecting brackets.
- s : Spacing between side frames, in m.

Figure 3 : Connection with bracket within hopper and topside tanks

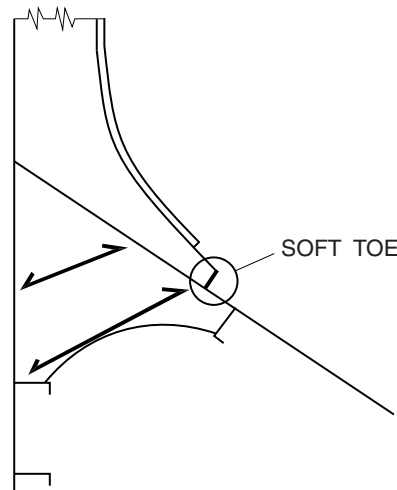

2.2.7 Tripping brackets

In way of the foremost cargo hold, side frames of asymmetrical section are to be fitted with sloped tripping brackets every two frames, as shown in Fig 4.

In way of the other holds, side frames of asymmetrical sections are to be fitted with sloped tripping brackets every two frames where the web height d is greater than 600 mm or the span ℓ is greater than 6 m.

Figure 4 : Tripping brackets

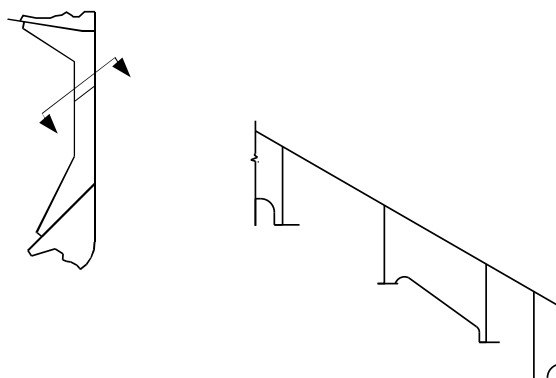

2.3 Double side structure

2.3.1 Side primary supporting members

The spacing of transverse side primary supporting members is to be not greater than 3 frame spaces.

Greater spacing may be accepted by the Society, on a case-by-case basis, depending on the results of the analysis carried out according to Part B, Chapter 8 for the primary supporting members in the cargo holds.

In any case, transverse side primary supporting members are to be fitted in line with web frames in hopper and topside tanks.

2.4 Deck structure

2.4.1 Topside tank sloping plates

The spacing of web frames in topside tanks is to be not greater than 6 frame spaces.

Greater spacing may be accepted by the Society, on a case-by-case basis, depending on the results of the analysis carried out according to Part B, Chapter 8 for the primary supporting members in the cargo holds.

2.4.2 Deck between hatches

The cross decks between hatches are generally to be transversely framed.

Connection of the strength deck at side with the deck between hatches is to be ensured by a plate of intermediate thickness.

2.4.3 Connection of hatch end beams with deck structures

The connection of hatch end beams with deck structures is to be properly ensured by fitting inside the topside tanks additional web frames or brackets.

2.4.4 Topside tank structure

Topside tank structures are to extend as far as possible within the machinery spaces and are to be adequately tapered.

3 Design loads

3.1 Loading conditions for longitudinal strength assessment

3.1.1 Seagoing conditions

In addition to the loading conditions specified in Pt B, Ch 5, Sec 8, the following seagoing loading conditions are to be included, as a minimum, in the loading manual:

- a) Cargo loading conditions defined in [3.1.2], as applicable.
- b) Ballast conditions with all ballast tanks 100% full,
- c) Heavy ballast condition, mandatory only for ships assigned the navigation notation **unrestricted navigation**, where:
 - the ballast tanks may be full, partially full or empty. Where ballast tanks are partially full, the conditions in Pt B, Ch 5, Sec 8, [3.1.1] are to be complied with
 - at least one cargo hold adapted for the carriage of water ballast at sea, where required or provided, is to be full
 - The propeller immersion ℓ_p / D_p is to be at least 60%
 - The trim is to be by the stern and is not to exceed $0,015L_{LL}$
 - The moulded forward draught is not to be taken less than the smaller of $0,03L_{LL}$ or 8 m.

3.1.2 Cargo loading conditions

- Homogeneous cargo loaded condition where the cargo density corresponds to all cargo holds, including hatchways, being 100% full at scantling draught with all ballast tanks empty.
- Homogeneous cargo loaded condition where the cargo density is taken equal to $3,0 \text{ t/m}^3$, and all cargo holds are taken with the same filling ratio (cargo mass/hold cubic capacity) in all cargo holds at scantling draught with all ballast tanks empty.
In cases where the cargo density applied for this design loading condition is different from $3,0 \text{ t/m}^3$, the maximum density of the cargo that the ship is allowed to carry is to be indicated.
- Non-homogeneous cargo loaded condition, for ships which service notation is completed by the additional service feature **nonhomload**. These conditions are to include cases where some holds may be empty, at a draught up to the scantling draught, if such conditions are intended to be operated.

3.2 Hull girder loads in flooded conditions

3.2.1 Application

These requirements apply to all types of bulk carriers of length greater than or equal to 150 m intended for the carriage of bulk cargoes having dry bulk cargo density of $1,0 \text{ t/m}^3$ or above and having the service notation **bulk carrier** or **self-unloading bulk carrier ESP** where the unloading system maintains the watertightness during seagoing operations.

3.2.2 Flooding assumptions

Each cargo hold is to be considered individually flooded up to the equilibrium waterline. For ships assigned the service notation **self-unloading bulk carrier ESP** and equipped with unloading systems that do not maintain watertightness, the longitudinal strength in the flooded conditions are to be considered using the extent to which the flooding may occur.

Appropriate permeabilities and bulk densities are to be used for any cargo carried. For iron ore, a minimum permeability of 0,3 with a corresponding bulk density of 3,0 t/m³ is to be used. For cement, a minimum permeability of 0,3 with a corresponding bulk density of 1,3 t/m³ is to be used. In this respect, "permeability" for dry bulk cargo means the ratio of the floodable volume between the particles, granules or any larger pieces of the cargo, to the gross volume of the bulk cargo.

The permeability of empty cargo spaces and volume left in loaded cargo spaces above any cargo is to be taken equal to 0,95.

For packed cargo conditions (such as in the case of steel mill products), the actual density of the cargo is to be used with a permeability of zero.

3.2.3 Still water hull girder loads

The permissible still water loads $M_{sw,f}$ and $Q_{sw,f}$ in flooded conditions are to be calculated for each of the cargo and ballast conditions considered in the intact longitudinal strength calculations, as specified in [3.1] except that harbour conditions, docking condition afloat, loading and unloading transitory conditions in port and loading conditions encountered during ballast water exchange need not be considered.

3.2.4 Wave hull girder loads

The wave loads in flooded conditions are taken as follows:

- $M_{ww,f}$: Vertical wave bending moment, in kN.m, in flooded conditions, at the hull transverse section under consideration, to be taken equal to 0,8 M_{ww}
- M_{ww} : Vertical wave bending moment in seagoing operation, in kN.m, at the hull transverse section considered, defined in Pt B, Ch 5, Sec 4, [3.1.1]
- $Q_{ww,f}$: Vertical wave shear force, in kN, in flooded conditions, at the hull transverse section under consideration, to be taken equal to 0,8 Q_{ww}
- Q_{ww} : Vertical wave shear force in seagoing condition, in kN, at the hull transverse section considered, defined in Pt B, Ch 5, Sec 4, [3.2.1].

3.3 Load combinations for direct strength analysis

3.3.1 Applicable general load combinations

The following loading conditions are to be considered for direct strength analysis:

- Full load and scantling draught T_{SC} , the loaded holds being completely filled with cargo.
Unless otherwise specified, this loading condition is to be associated with the BP dynamic load cases
- Full load, the cargo density taken equal to 3 t/m³ unless otherwise specified in the loading manual, and scantling draught T_{SC} .
Unless otherwise specified, this loading condition is to be associated with the BP dynamic load cases
- Heavy ballast condition and minimum design heavy ballast draught T_{BAL-H} .
Unless otherwise specified, this loading condition is to be associated with the HVM, FVM and BR dynamic load cases
- Multi-port (MP) loading conditions, if allowed by the loading manual, and draught amidships corresponding to these conditions in the loading manual.
Unless otherwise specified, these loading conditions are to be associated with the all the dynamic load cases
- Alternate loading conditions, if allowed by the loading manual, and draught amidships corresponding to these conditions in the loading manual.
Unless otherwise specified, these loading conditions are to be associated with the all dynamic load cases

In addition, harbour conditions covering the loading/unloading sequences and associated draughts amidships as defined in the loading manual are to be considered.

4 Hull girder strength

4.1 Hull girder yield strength in flooded conditions

4.1.1 Application

These requirements apply to all types of bulk carriers of length greater than or equal to 150 m intended for the carriage of bulk cargoes having dry bulk cargo density of 1,0 t/m³ or above.

Such ships are also to have their hull girder strength checked for the flooded conditions specified in [3.2].

The damaged structure is assumed to remain fully effective in resisting the applied loads.

4.1.2 Stresses

The normal stresses in flooded conditions $\sigma_{L,f}$ at any point are to be obtained, in N/mm², according to the requirements given in Pt B, Ch 6, Sec 1, [2.1.1], in which M_{sw} and M_{wv} are to be replaced respectively by $M_{sw,f}$ and $M_{wv,f}$ as defined in [3.2].

The shear stresses $\tau_{L,f}$ of the side shell and the inner hull (longitudinal bulkhead) if any, at any point, are to be obtained, in N/mm², according to the requirements given in Pt B, Ch 6, Sec 1, [2.2.1], in which Q_{sw} and Q_{wv} are to be replaced respectively by $Q_{sw,f}$ and $Q_{wv,f}$ as defined in [3.2].

The equivalent Von Mises stresses $\sigma_{eq,f}$ are to be obtained, in N/mm², according to the requirements given in Pt B, Ch 6, Sec 1, [3.5.1], in which σ_L and τ_L are to be replaced respectively by $\sigma_{L,f}$ and $\tau_{L,f}$.

4.1.3 Checking criteria

It is to be checked that the equivalent Von Mises stresses $\sigma_{eq,f}$ calculated according to [4.1.2] is in compliance with the acceptance criteria Pt B, Ch 6, Sec 1, [3.5.1] for seagoing operations.

5 Hull scantlings of bulk carriers

5.1 Plating

5.1.1 Minimum net thickness of side plating

The net thickness of the side plating located between hopper and topside tanks is to be not less than the value obtained, in mm, from the following formula: $t_{MIN} = L^{0.5} - t_C$

5.2 Ordinary stiffeners

5.2.1 Minimum net thicknesses of side frames

The net thicknesses of side frames and their brackets, in way of cargo holds, are to be not less than the values given in Tab 1.

Table 1 : Minimum net thicknesses of side frames

Item	Minimum net thickness, in mm
Side frame webs	$C_L (7,0 + 0,03L_1) - t_C$
Lower end bracket	The greater of: <ul style="list-style-type: none"> $C_L (7,0 + 0,03L_1) + 2 - t_C$ as fitted net thickness of side frame web
Upper end bracket	The greater of: <ul style="list-style-type: none"> $C_L (7,0 + 0,03L_1) - t_C$ as fitted net thickness of side frame web
Note 1:	
C_L	: Coefficient equal to: <ul style="list-style-type: none"> 1,15 for side frames in way of the foremost cargo hold 1,0 for side frames in way of other cargo holds
L_1	: Ship's length, in m, defined in Pt B, Ch 1, Sec 3, Tab 1.

5.2.2 Scantlings of side frames abaft the collision bulkhead

The net moment of inertia I , in cm⁴, of the three side frames located immediately abaft the collision bulkhead is not to be taken less than:

$$I = 0,18 \frac{P_{SF}^4}{n}$$

where:

n : Frame number of considered side frame counted from the collision bulkhead to the frame in question, taken equal to 1, 2 or 3.

As an alternative, supporting structures, such as horizontal stringers, are to be fitted between the collision bulkhead and a side frame which is in line with transverse webs fitted in both the topside tank and hopper tank, maintaining the continuity of the forepeak stringers within the foremost hold.

5.2.3 Hopper and topside tank ordinary stiffeners

These requirements apply to the ordinary stiffeners of side and sloped longitudinal bulkheads, within hopper and topside tanks, which support the connecting brackets fitted in way of the side frame brackets, according to [2.2.6].

The scantlings of these ordinary stiffeners are to be determined according to Pt B, Ch 7, Sec 4, with their span measured according to Pt B, Ch 4, Sec 6, [1.1] between hopper or topside tank primary supporting members.

Alternative arrangements may be considered by the Society on a case-by-case basis. In these cases, the scantlings of the above ordinary stiffeners are to be determined for the purpose of effectively supporting the connecting brackets.

5.3 Buckling check in flooded conditions

5.3.1 Application

These requirements apply to all types of bulk carriers of length greater than or equal to 150 m intended for the carriage of bulk cargoes having dry bulk cargo density 1,0 t/m³ or above.

5.3.2 General

The following elements are to be checked in the flooded conditions specified in [3.2] according to Pt B, Ch 9, Sec 1, considering the hull girder stresses defined in [4.1.2]:

- Plating and ordinary stiffeners contributing to the hull girder longitudinal strength
- Web plate of transverse corrugated bulkhead.

6 Protection of hull metallic structures

6.1 Protection of cargo holds

6.1.1 Coating

It is the responsibility of the shipbuilder and of the Owner to choose coatings suitable for the intended cargoes, in particular for the compatibility with the cargo, and to see that they are applied in accordance with the Manufacturer's requirements.

6.1.2 Application

All internal and external surfaces of hatch coamings and hatch covers and all internal surfaces of cargo holds (side and transverse bulkheads) are to have an efficient protective coating, of an epoxy type or equivalent, applied in accordance with the Manufacturer's recommendations.

The side (single and double skin) and transverse bulkhead areas to be coated are specified in [6.1.3] to [6.1.5].

6.1.3 Single side areas to be coated

The areas to be coated are:

- the internal surfaces of the side plating
- the side frames with end brackets
- the internal surfaces of the topside tank sloping plates and, for a distance of 300 mm below, of the hopper tank sloping plates.

These areas are shown in Fig 5.

6.1.4 Double side areas to be coated

The areas to be coated are the internal surfaces of:

- the inner side plating
- the internal surfaces of the topside tank sloping plates and the hopper tank sloping plates for a distance of 300 mm below their upper ends.

These areas are shown in Fig 6.

6.1.5 Transverse bulkhead areas to be coated

The areas to be coated are the upper parts down to 300 mm below the top of the lower stool. Where there is no lower stool, the area to be coated is the whole transverse bulkhead.

These areas are shown in Fig 7.

Figure 5 : Single side - Areas to be coated

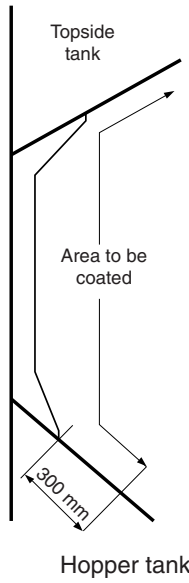

Figure 6 : Double side - Areas to be coated

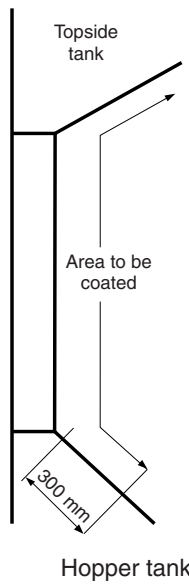
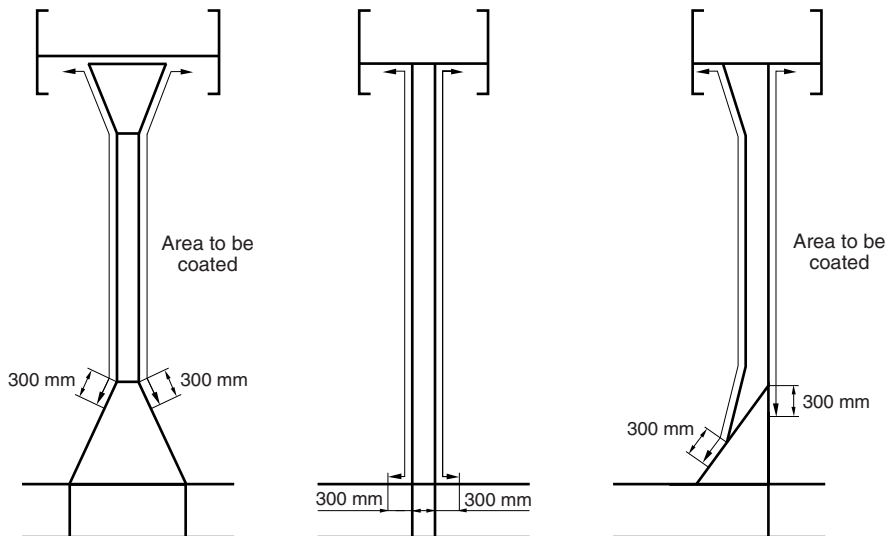

Figure 7 : Transverse bulkheads - Areas to be coated



7 Construction and testing

7.1 Welding and weld connections

7.1.1 The weld factors for some hull structural connections are specified in Tab 2. These weld factors are to be used, in lieu of the corresponding factors specified in Pt B, Ch 13, Sec 3, Tab 1, to calculate the leg length of fillet weld T connections according to Pt B, Ch 13, Sec 3, [3.2].

7.1.2 For the connections in Tab 2, continuous fillet welding is to be adopted.

7.2 Special structural details

7.2.1 The specific requirements in Pt B, Ch 13, Sec 5, [2] are to be complied with.

Table 2 : Weld factor w_F

Hull area	Connection		Weld factor w_F	
	of	to		
Double bottom in way of cargo holds	girders	bottom and inner bottom plating	0,48	
		floors (interrupted girders)		
	floors	bottom and inner bottom plating		
		girders (interrupted floors)		
Side	web of side frames and brackets	side plating, hopper and topside tank sloping plates, face plates	in zone "a" (1)	0,63 (2)
			in zone "b" (1)	0,56 (2)

(1) Zones "a" and "b" are defined in Fig 8.
 (2) Where the hull form is such as to prohibit an effective fillet weld, the Society may require edge preparation of the web of side frame and bracket to be carried out in order to ensure the same efficiency as the required weld connections.

Figure 8 : Zones "a" and "b" of weld connections of side frames

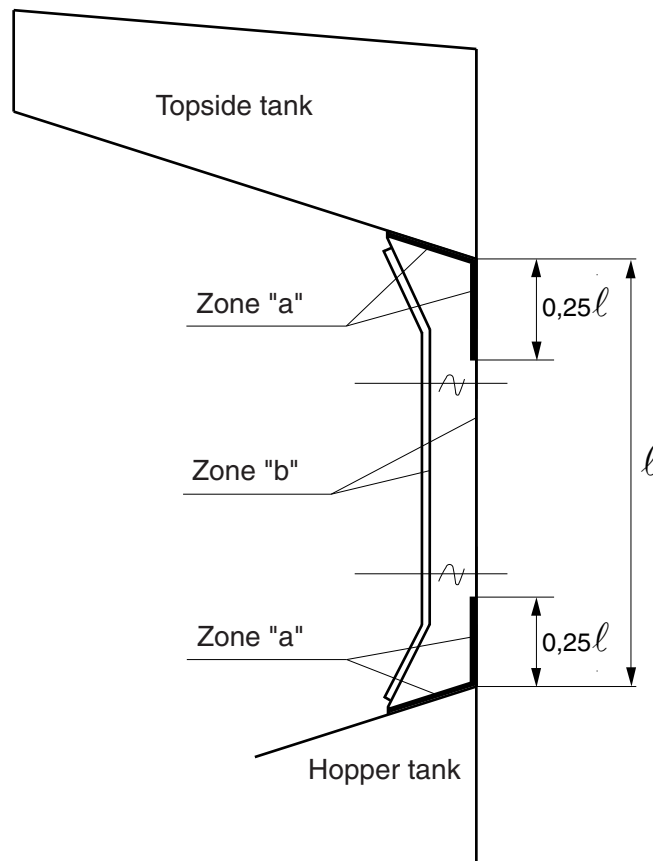

Appendix 1 Intact Stability Criteria for Grain Loading

1 Calculation of assumed heeling moments due to cargo shifting

1.1 Stowage of bulk grain

1.1.1 General

All necessary and reasonable trimming is to be performed to level all free grain surfaces and to minimise the effect of grain shifting.

1.1.2 Filled compartment trimmed

In any filled compartment trimmed, as defined in Ch 4, Sec 3, [1.1.2], the bulk grain is to be trimmed so as to fill all spaces under the decks and hatch covers to the maximum extent possible.

1.1.3 Filled compartment untrimmed

In any filled compartment untrimmed, as defined in Ch 4, Sec 3, [1.1.3], the bulk grain is to be filled to the maximum extent possible in way of the hatch opening but may be at its natural angle of repose outside the periphery of the hatch opening. A filled compartment may qualify for this classification if it falls into one of the following categories:

- the Society may, under [1.7], grant dispensation from trimming in those cases where the underdeck void geometry resulting from free flowing grain in a compartment, which may be provided with feeder ducts, perforated decks or other similar means, is taken into account when calculating the void depths, or
- the compartment is "specially suitable" as defined in Ch 4, Sec 3, [1.1.6], in which case dispensation may be granted from trimming the ends of that compartment.

1.1.4 Grain in partially filled compartments

If there is no bulk grain or other cargo above a lower cargo space containing grain, the hatch covers are to be secured in an approved manner having regard to the mass and permanent arrangements provided for securing such covers.

When bulk grain is stowed on top of closed 'tweendeck hatch covers which are not grain-tight, such covers are to be made grain-tight by taping the joints, covering the entire hatchway with tarpaulins or separation cloths, or other suitable means.

After loading, all free grain surfaces in partly filled compartments are to be level.

1.1.5 Cargo securing

Unless account is taken of the adverse heeling effect due to the grain shift according to these Rules, the surface of the bulk grain in any partly filled compartment is to be secured so as to prevent a grain shift by overstowing as described in [1.9.1] to [1.9.3]. Alternatively, in partly filled compartments, the bulk grain surface may be secured by strapping or lashing as described in [1.9.4] or [1.9.5].

Lower cargo spaces and 'tweendeck spaces in way thereof may be loaded as one compartment provided that, in calculating transverse heeling moments, proper account is taken of the flow of grain into the lower spaces.

1.1.6 Longitudinal division

In filled compartments trimmed, filled compartments untrimmed and partly filled compartments, longitudinal divisions may be installed as a device to reduce the adverse heeling effect of grain shift provided that:

- the division is grain-tight,
- the construction meets the requirements in Part B for longitudinal bulkheads; if no particular requirement is foreseen see MSC Res. 23(59)sect 11-14); and
- in 'tweendecks, if fitted, the division extends from deck to deck and in other cargo spaces the division extends downwards from the underside of the deck or hatch covers, as described in [1.3.2] a) (second bullet), Note 2, [1.3.2] b), Note 7, or [1.6.1] b), as applicable.

1.2 General assumptions

1.2.1 Voids in spaces loaded with grain

For the purpose of calculating the adverse heeling moment due to a shift of cargo surface in ships carrying bulk grain it is to be assumed that:

- in filled compartments which have been trimmed in accordance with [1.1.2], a void exists under all boundary surfaces having an inclination to the horizontal less than 30° and that void is parallel to the boundary surface having an average depth calculated according to the formula:

$$V_d = V_{d1} + 0,75 (d - 600)$$

where:

V_d : Average void depth, in mm

V_{d1} : Standard void depth, in mm, from Tab 1

d : Actual girder depth, in mm.

In any case, V_d is to be assumed equal to or greater than 100 mm.

- b) within filled hatchways and in addition to any open void within the hatch cover there is a void of average depth of 150 mm measured down to the grain surface from the lowest part of the hatch cover or the top of the hatch side coaming, whichever is the lower.
- c) in a filled compartment untrimmed which is exempted from trimming outside the periphery of the hatchway by the provisions of [1.1.3] a), it is to be assumed that the surface of the grain after loading will slope into the void space underdeck, in all directions, at an angle of 30° to the horizontal from the edge of the opening which establishes the void.
- d) In a filled compartment untrimmed which is exempted from trimming in the ends of the compartment under the provisions of [1.1.3] b), it is to be assumed that the surface of the grain after loading will slope in all directions away from the filling area at an angle of 30° from the lower edge of the hatch end beam. However, if feeding holes are provided in the hatch end beams in accordance with Tab 2, then the surface of the grain after loading is to be assumed to slope in all directions, at an angle of 30° from a line on the hatch end beam which is the mean of the peaks and valleys of the actual grain surface as shown in Fig 1.

The description of the pattern of grain surface behaviour to be assumed in partly filled compartments is contained in [1.6].

Table 1 : Standard void depth

Distance, in m, from hatch end or hatch side to boundary of compartment	Standard void depth V_{d1} in mm
0,5	570
1,0	530
1,5	500
2,0	480
2,5	450
3,0	440
3,5	430
4,0	430
4,5	430
5,0	430
5,5	450
6,0	470
6,5	490
7,0	520
7,5	550
8,0	590

Note 1: For boundary distances greater than 8,0 m, the standard void depth V_{d1} is to be linearly extrapolated with 80 mm increases for each 1,0 m increase in length.

Note 2: In the corner area of a compartment, the boundary distance is to be the perpendicular distance from the line of the hatch side girder or the line of the hatch end beam to the boundary of the compartment, whichever is the greater. The girder depth d is to be taken as the depth of the hatch side girder or the hatch end beam, whichever is the lesser.

Note 3: Where there is a raised deck clear of the hatchway, the average void depth measured from the underside of the raised deck is to be calculated using the standard void depth in association with a girder depth of the hatch end beam plus the height of the raised deck.

Table 2 : Requirements for feeding holes

Minimum diameter, in mm	Area, in cm ²	Maximum spacing, in m
90	63,6	0,60
100	78,5	0,75
110	95,0	0,90
120	113,1	1,07
130	133,0	1,25
140	154,0	1,45
150	177,0	1,67
160	201,0	1,90
170 or above	227,0	2,00

Figure 1 : Effective grain surface to be assumed

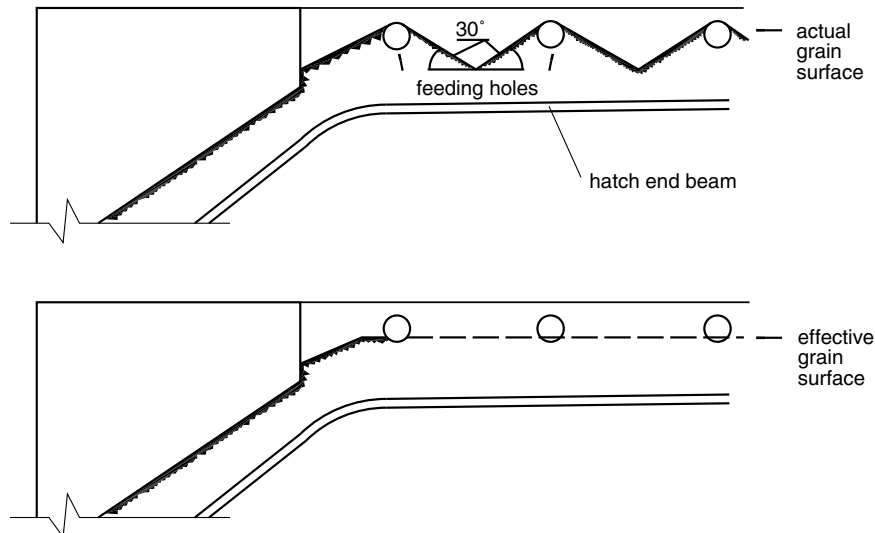

1.2.2 Assumptions in filled compartments trimmed

For the purpose of demonstrating compliance with the stability criteria specified in Ch 4, Sec 3, [1.2.3], the ship's stability calculations are normally to be based upon the assumption that the centre of gravity of cargo in a filled compartment trimmed is at the volumetric centre of the whole cargo space. In those cases where the Society authorises account to be taken of the effect of assumed underdeck voids on the vertical position of the centre of gravity of the cargo in filled compartments trimmed, it is necessary to compensate for the adverse effect of the vertical shift of grain surfaces by increasing the assumed heeling moment due to the transverse shift of grain as follows:

$$M_{H,T} = 1,06 M_{H,C}$$

where:

$M_{H,T}$: Total heeling moment, in t.m

$M_{H,C}$: Calculated transverse heeling moment, in t.m.

In all cases the weight of cargo in a filled compartment trimmed is to be the volume of the whole cargo space divided by the stowage factor.

1.2.3 Assumptions in filled compartments untrimmed

The centre of gravity of cargo in a filled compartment untrimmed is to be taken to be the volumetric centre of the whole cargo compartment with no account being allowed for voids. In all cases the weight of cargo is to be the volume of the cargo (resulting from the assumptions stated in [1.2.1] c) or [1.2.1] d)) divided by the stowage factor.

1.2.4 Assumptions in partially filled compartments

In partly filled compartments the adverse effect of the vertical shift of grain surfaces is to be taken into account as follows:

$$M_{H,T} = 1,12 M_{H,C}$$

where $M_{H,T}$ and $M_{H,C}$ are defined in [1.2.2].

1.2.5 Equivalent methods

Any other equally effective method may be adopted to make the compensation required in [1.2.2] and [1.2.4].

1.3 Assumed volumetric heeling moment of a filled compartment trimmed

1.3.1 General

The pattern of grain surface movement relates to a transverse section across the portion of the compartment being considered and the resultant heeling moment is to be multiplied by the length to obtain the total moment for that portion.

The assumed transverse heeling moment due to grain shifting is a consequence of final changes of shape and position of voids after grain has moved from the high side to the low side.

The resulting grain surface after shifting is to be assumed to be at 15° to the horizontal.

In calculating the maximum void area that can be formed against a longitudinal structural member, the effects of any horizontal surfaces, e.g. flanges or face bars, are to be ignored.

The total areas of the initial and final voids are to be equal.

Longitudinal structural members which are grain-tight may be considered effective over their full depth except where they are provided as a device to reduce the adverse effect of grain shift, in which case the provisions of [1.1.6] are to apply.

A discontinuous longitudinal division may be considered effective over its full length.

1.3.2 Assumptions

In the following paragraphs it is assumed that the total heeling moment for a compartment is obtained by adding the results of separate consideration of the following portions:

- a) before and abaft hatchways:
 - if a compartment has two or more main hatchways through which loading may take place, the depth of the underdeck void for the portion or portions between such hatchways is to be determined using the fore and aft distance to the mid-point between the hatchways
 - after the assumed shift of grain the final void pattern is to be as shown in Fig 2.
- b) In and abreast of hatchways without longitudinal division, after the assumed shift of grain the final void pattern is to be as shown in Fig 3 or Fig 4.

Figure 2 : Final void pattern

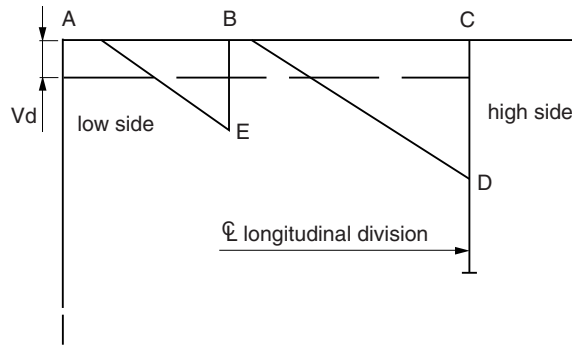

Note 1: If the maximum void area which can be formed against the girder at B is less than the initial area of the void under AB, i.e. $AB \cdot Vd$, the excess area is to be assumed to transfer to the final void on the high side.

Note 2: If, for example, the longitudinal division at C is one which has been provided in accordance with [1.1.6], it is to extend to at least 0,6 m below D or E, whichever gives the greater depth.

Figure 3 : Final void pattern

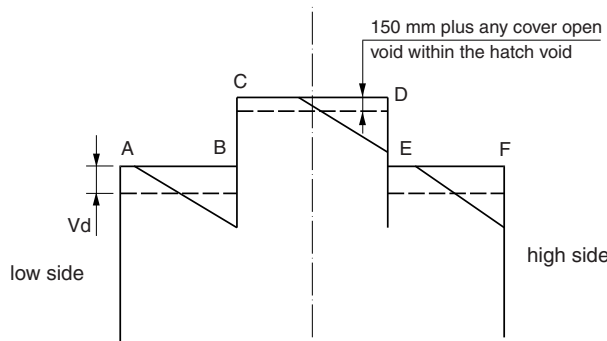

Note 3: AB: Any area in excess of that which can be formed against the girder at B is to transfer to the final void area in the hatchway.

Note 4: CD: Any area in excess of that which can be formed against the girder at E is to transfer to the final void area on the high side.

Figure 4 : Final void pattern

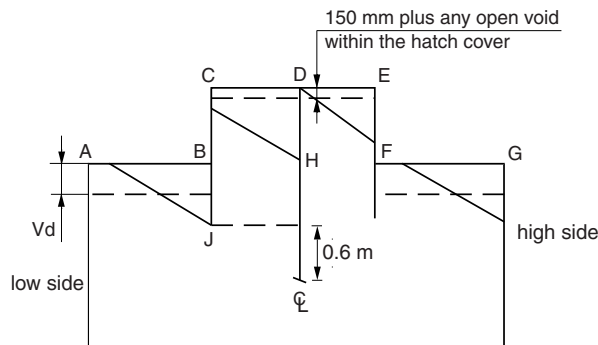

Note 5: The excess void area from AB is to transfer to the low side half of the hatchway in which two separate final void areas are formed: one against the centreline division and the other against the hatch side coaming and girder on the high side.

Note 6: If a bagged saucer or bulk bundle is formed in a hatchway it is to be assumed for the purpose of calculating the transverse heeling moment that such a device is at least equivalent to the centreline division.

Note 7: If the centreline division is one which has been provided in accordance with [1.1.6], it is to extend to at least 0,6 m below H or J, whichever gives the greater depth.

1.3.3 Compartment loaded in combination

The following paragraphs describe the patterns of void behaviour which are to be assumed when compartments are loaded in combination:

a) without effective centreline divisions:

- under the upper deck:
as for the single deck arrangement described in [1.3.2] a) (second bullet) and [1.3.2] b).
- under the second deck (if applicable):
the area of void available for transfer from the low side, i.e. original void area less area against the hatch side girder, is to be assumed to transfer as follows: one half to the upper deck hatchway and one quarter each to the high side under the upper and second deck.
- under the third and lower decks (if applicable):
the void areas available for transfer from the low side of each of these decks are to be assumed to transfer in equal quantities to all the voids under the decks on the high side and the void in the upper deck hatchway.

b) with effective centreline divisions which extend into the upper deck hatchway:

- at all deck levels abreast of the division the void areas available for transfer from the low side are to be assumed to transfer to the void under the low side half of the upper deck hatchway
- at the deck level immediately below the bottom of the division the void area available for transfer from the low side is to be assumed to transfer as follows: one half to the void under the low side half of the upper deck hatchway and the remainder in equal quantities to the voids under the decks on the high side
- at deck levels lower than those described above, the void area available for transfer from the low side of each of those decks is to be assumed to transfer in equal quantities to the voids in each of the two halves of the upper deck hatchway on each side of the division and the voids under the decks on the high side.

c) with effective centreline divisions which do not extend into the upper deck hatchway:

Since no horizontal transfer of voids may be assumed to take place at the same deck level as the division, the void area available for transfer from the low side at this level is to be assumed to transfer above the division to voids on the high side in accordance with the principles of a) and b).

1.4 Assumed volumetric heeling moment of a filled compartment untrimmed

1.4.1 General

All the provisions for filled compartments trimmed set forth in [1.3] are to also apply to filled compartments untrimmed, except as reported in [1.4.2].

1.4.2 Additional requirements

In filled compartments untrimmed which are exempted from trimming outside the periphery of the hatchway under the provisions of [1.1.3] a), the following assumptions apply:

- a) The resulting grain surface after shifting is to be assumed to be at an angle of 25° to the horizontal. However, if in any section of the compartment, forward, aft, or abreast of the hatchway the mean transverse area of the void in that section is equal to or less than the area which would be obtained by application of [1.2.1] a), then the angle of grain surface after shifting in that section is to be assumed to be 15° to the horizontal.
- b) The void area at any transverse section of the compartment is to be assumed to be the same both before and after the grain shift, i.e. it is to be assumed that additional feeding does not occur at the time of the grain shift.

In filled compartments untrimmed which are exempted from trimming in the ends, forward and aft of the hatchway, under the provisions of [1.1.3] b), the following assumptions apply:

- a) the resulting grain surface abreast of the hatchway after shifting is to be assumed to be at an angle of 15° to the horizontal
- b) the resulting grain surface in the ends, forward and aft of the hatchway after shifting is to be assumed to be at an angle of 25° to the horizontal.

1.5 Assumed volumetric heeling moments in trunks

1.5.1 After the assumed shift of grain the final void pattern is to be as shown in Fig 5.

Note 1: If the wing spaces in way of the trunk cannot be properly trimmed in accordance with [1.1], it is to be assumed that a 25° surface shift takes place.

1.6 Assumed volumetric heeling moment of a partly filled compartment

1.6.1

- When the free surface of the bulk grain has not been secured in accordance with [1.9.1] to [1.9.3], [1.9.4], or [1.9.5], it is to be assumed that the grain surface after shifting is at 25° to the horizontal.
- In a partly filled compartment, a division, if fitted, is to extend from one eighth of the maximum breadth of the compartment above the level of the grain surface and to the same distance below the grain surface.
- In a compartment in which the longitudinal divisions are not continuous between the transverse boundaries, the length over which any such divisions are effective as devices to prevent full width shifts of grain surfaces is to be taken to be the actual length of the portion of the division under consideration less two sevenths of the greater of the transverse distances between the division and its adjacent division or ship side. This correction does not apply in the lower compartments of any combination loading in which the upper compartment is either a filled compartment or a partly filled compartment.

Figure 5 : Assumed volumetric heeling moment in trunks

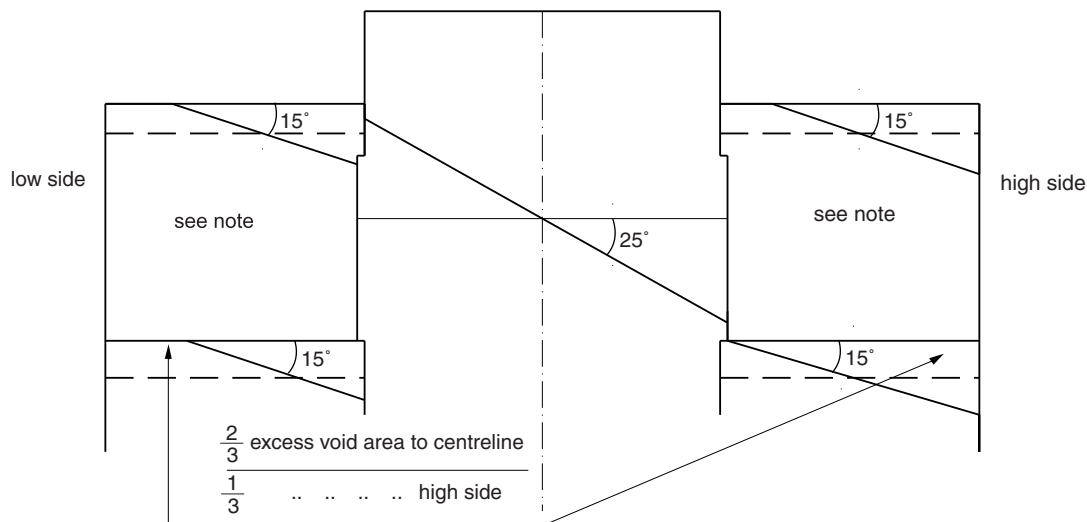

1.7 Other assumptions

1.7.1 The Society may authorise departure from the assumptions contained in these Rules in those cases where it considers this to be justified having regard to the provisions for loading or the structural arrangements, provided the stability criteria in Ch 4, Sec 3, [1.2.3] are met.

Where such authorisation is granted under this regulation, particulars shall be included in the grain loading manual.

These particulars include the additional calculation of heeling moments for filled holds with untrimmed ends, an example of which is reported in [2.1].

1.8 Saucers

1.8.1 For the purpose of reducing the heeling moment a saucer may be used in place of a longitudinal division in way of a hatch opening only in a filled trimmed compartment as defined in Ch 4, Sec 3, [1.1.2], except in the case of linseed and other seeds having similar properties, where a saucer may not be substituted for a longitudinal division. If a longitudinal division is provided, it is to meet the requirements of [1.1.6].

1.8.2 The depth of the saucer, measured from the bottom of the saucer to the deck line, is to be as follows:

- for ships with a moulded breadth of up to 9,1 m, not less than 1,2 m
- for ships with a moulded breadth of 18,3 m or more, not less than 1,8 m
- for ships with a moulded breadth between 9,1 m and 18,3 m, the minimum depth of the saucer is to be calculated by interpolation.

1.8.3 The top (mouth) of the saucer is to be formed by the underdeck structure in way of the hatchway, i.e. hatch side girders or coamings and hatch end beams. The saucer and hatchway above are to be completely filled with bagged grain or other suitable cargo laid down on a separation cloth or its equivalent and stowed tightly against adjacent structure so as to have a bearing contact with such structure to a depth equal to or greater than one half of the depth specified in [1.8.2].

If hull structure to provide such bearing surface is not available, the saucer is to be fixed in position by steel wire rope, chain, or double steel strapping as specified in [1.9.4] d) and spaced not more than 2,4 m apart.

1.8.4 As an alternative to filling the saucer in a filled trimmed compartment with bagged grain or other suitable cargo, a bundle of bulk grain may be used provided that:

- a) the dimensions and means for securing the bundle in place are the same as specified for a saucer in [1.8.2] and [1.8.3]
- b) the saucer is lined with a material acceptable to the Society having a tensile strength of not less than 2,687 N per 5 cm strip and which is provided with suitable means for securing at the top
- c) as an alternative to b), a material acceptable to the Society having a tensile strength of not less than 1,344 N per 5 cm strip may be used if the saucer is constructed as follows:
 - athwartship lashings acceptable to the Society are to be placed inside the saucer formed in the bulk grain at intervals of not more than 2,4 m. These lashings are to be of sufficient length to permit being drawn up tight and secured at the top of the saucer.
 - dunnage not less than 25 mm in thickness or other suitable material of equal strength and between 150 mm and 300 mm in width is to be placed fore and aft over these lashings to prevent the cutting or chafing of the material which is to be placed thereon to line the saucer
- d) the saucer is to be filled with bulk grain and secured at the top except that when using material approved under c) further dunnage is to be laid on top after lapping the material before the saucer is secured by setting up the lashings
- e) if more than one sheet of material is used to line the saucer they are to be joined at the bottom either by sewing or by a double lap
- f) the top of the saucer is to be coincidental with the bottom of the beams when these are in place and suitable general cargo or bulk grain may be placed between the beams on top of the saucer.

1.9 Overstowing arrangements and securing

1.9.1 Bagged grain

Where bagged grain or other suitable cargo is utilised for the purpose of securing partly filled compartments, the free grain surface is to be level and is to be covered with a separation cloth or equivalent or by a suitable platform. Such platform is to consist of bearers spaced not more than 1,2 m apart and 25 mm boards laid thereon spaced not more than 100 mm apart. Platforms may be constructed of other materials provided they are deemed by the Society to be equivalent.

1.9.2 Separating platform

The platform or separation cloth is to be topped off with bagged grain tightly stowed and extending to a height of not less than one sixteenth of the maximum breadth of the free grain surface or 1,2 m, whichever is the greater.

1.9.3 Equivalent cargo

The bagged grain is to be carried in sound bags which are to be well filled and securely closed.

Instead of bagged grain, other suitable cargo tightly stowed and exerting at least the same pressure as bagged grain stowed in accordance with [1.9.2] may be used.

1.9.4 Strapping or lashing

When, in order to eliminate heeling moments in partly filled compartments, strapping or lashing is utilised, the securing is to be accomplished as follows:

- a) the grain is to be trimmed and levelled to the extent that it is very slightly crowned and covered with burlap separation cloths, tarpaulins or the equivalent
- b) the separation cloths and/or tarpaulins are to overlap by at least 1,8 m
- c) two solid floors of rough 25 mm by 150 mm to 300 mm lumber are to be laid with the top floor running longitudinally and nailed to an athwartship bottom floor. Alternatively, one solid floor of 50 mm lumber, running longitudinally and nailed over the top of a 50 mm bottom bearer not less than 150 mm wide, may be used. The bottom bearers are to extend the full breadth of the compartment and are to be spaced not more than 2,4 m apart. Arrangements utilising other materials and deemed by the Society to be equivalent to the foregoing may be accepted.
- d) Steel wire rope (19 mm diameter or equivalent), double steel strapping (50 mm x 1,3 mm and having a breaking load of at least 49 kN), or chain of equivalent strength, each of which is to be set tightly by means of a 32 mm turnbuckle, may be used for lashings. A winch tightener, used in conjunction with a locking arm, may be substituted for the 32 mm turnbuckle when steel strapping is used, provided suitable wrenches are available for setting up as necessary.

When steel strapping is used, not less than three crimp seals are to be used for securing the ends. When wire is used, not less than four clips are to be used for forming eyes in the lashings.
- e) Prior to the completion of loading the lashings are to be positively attached to the framing at a point approximately 450 mm below the anticipated final grain surface by means of either a 25 mm shackle or beam clamp of equivalent strength
- f) the lashings are to be spaced not more than 2,4 m apart and each is to be supported by a bearer nailed over the top of the fore and aft floor. This bearer is to consist of lumber of not less than 25 mm by 150 mm or its equivalent and is to extend the full breadth of the compartment.
- g) During the voyage the strapping is to be regularly inspected and set up where necessary.

1.9.5 Securing with wire mesh

When, in order to eliminate grain heeling moments in partly filled compartments, strapping or lashing is utilised, the securing may, as an alternative to the method described in [1.9.4], be accomplished as follows:

- a) the grain is to be trimmed and levelled to the extent that it is very slightly crowned along the fore and aft centreline of the compartment
- b) the entire surface of the grain is to be covered with burlap separation cloths, tarpaulins, or the equivalent. The covering material is to have a tensile strength of not less than 1,344 N per 5 cm strip.
- c) Two layers of wire reinforcement mesh are to be laid on top of the burlap or other covering. The bottom layer is to be laid athwartship and the top layer is to be laid longitudinally. The lengths of wire mesh are to be overlapped at least 75 mm. The top layer of mesh is to be positioned over the bottom layer in such a manner that the squares formed by the alternate layer measure approximately 75 mm by 75 mm. The wire reinforcement mesh is the type used in reinforced concrete construction. It is fabricated of 3 mm diameter steel wire having a breaking strength of not less than 52 kN/cm², welded in 150 mm x 150 mm squares. Wire mesh having mill scale may be used but mesh having loose, flaking rust may not be used.
- d) The boundaries of the wire mesh, at the port and starboard side of the compartment, are to be retained by wood planks 150 mm x 50 mm,
- e) hold-down lashings, running from side to side across the compartment, are to be spaced not more than 2,4 m apart except that the first and the last lashing are not to be more than 300 mm from the forward or after bulkhead, respectively. Prior to the completion of the loading, each lashing is to be positively attached to the framing at a point approximately 450 mm below the anticipated final grain surface by means of either a 25 mm shackle or beam clamp of equivalent strength. The lashing is to be led from this point over the top of the boundary plank described in d), which has the function of distributing the downward pressure exerted by the lashing. Two layers of 150 mm x 25 mm planks are to be laid athwartship centred beneath each lashing and extending the full breadth of the compartment.
- f) The hold-down lashings are to consist of steel wire rope (19 mm diameter or equivalent), double steel strapping (50 mm x 1,3 mm and having a breaking load of at least 49 kN), or chain of equivalent strength, each of which is to be set tight by means of a 32 mm turnbuckle. A winch tightener, used in conjunction with a locking arm, may be substituted for the 32 mm turnbuckle when steel strapping is used, provided suitable wrenches are available for setting up as necessary. When steel strapping is used, not less than three crimp seals are to be used for securing the ends. When wire rope is used, not less than four clips are to be used for forming eyes in the lashings.
- g) During the voyage the hold-down lashings are to be regularly inspected and set up where necessary.

2 Dispensation from trimming ends of holds in certain ships

2.1 Calculation example

2.1.1 General

As a result of the provisions in [1.1.3] and [1.7.1], dispensation may be granted from trimming the ends of holds in specially suitable ships, when requested, provided that an additional entry of heeling moments for filled holds with untrimmed ends is approved and included in the grain loading manual required in Ch 4, Sec 3, [1.2.2]. Untrimmed ends are to be treated as partly filled spaces and, accordingly, the grain surface in these portions of the hold is to be assumed to shift to an angle of 25° from the horizontal.

After taking into account the heeling moments due to the shift of grain in the untrimmed ends, dispensation may be granted provided the ship meets the stability criteria specified in Ch 4, Sec 3, [1.2.3].

This dispensation may be granted only to ships which are arranged with sloping bulkheads, port and starboard forming the longitudinal inner boundaries of topside tanks and which slope at an angle of 30° or more to the horizontal.

When calculating the geometry of the void beyond the hatch end, allowance may be made for feeding holes in the hatch and beam provided they meet the requirements reported in Tab 2.

The effective depth is to be taken as the distance from the underside of the deck to a horizontal line on the hatch end beam which is the mean between the peaks and valleys of the actual grain surface as shown in Fig 1.

2.1.2 Assumptions

In performing the calculation of the volumetric heeling moment, the grain in the hatchway is assumed to be filled to the maximum and the resulting surface shifted to an angle of 15° to the horizontal.

In the untrimmed end the surface of the grain will slope in all directions away from the filling area at an angle of 30° to the horizontal from the lower edge of the hatch end beam or, in certain cases from a higher level where feeding holes are provided.

The sum of the moments calculated for the ends and the moments for the hatchway give the total volumetric heeling moment for the compartment "filled - ends not trimmed" and is to be listed for any such compartment in the grain loading manual.

The information concerning full holds assumed to be trimmed and partly filled holds is to remain the same as at present.

2.1.3 Calculation of void areas

In ships having sloping topside tanks in each hold, the grain surface leans against topside tank bulkheads if its slope is equal to or greater than 30° to the horizontal; in this case no void occurs.

In the zone forward and abaft the hatch, the grain surface is located so as that the standard void depth V_d increases with the distance from the hatch.

For the void depth calculation, three different transversal sections, AA, BB and CC are taken into account, and for each of these sections, three different points ($A_1, A_2, A_3, B_1, B_2, B_3$ and C_1, C_2, C_3) are to be considered, as illustrated in Fig 6.

The distance between the points C_3 and B_2 , in m, is as follows:

$$C_3B_2 = \sqrt{(3^2 + 2^2)} = 3,61$$

and the void depth V_{d2} , in m, measured in B_2 is:

$$V_{d2} = 3,61 \tan 30^\circ + 0,60 = 2,68$$

The topside tank area A_W , in m^2 , (I + II) is as follows:

$$A_W = (6 \cdot 0,60) + \frac{6(\tan 30^\circ)6}{2} = 13,98$$

The void depth V_{d3}, V_{d2}, V_{d1} , in m, relevant to points A_3, A_2, A_1 of section AA is:

$$V_{d3} = 4 \tan 30^\circ + 0,60 = 2,91$$

$$V_{d2} = (\sqrt{3^2 + 4^2}) \tan 30^\circ + 0,60 = 3,49$$

$$V_{d1} = (\sqrt{6^2 + 4^2}) \tan 30^\circ + 0,60 = 4,76$$

The area $A_{V,AA}$, in m^2 , of the void in transversal section AA (calculated according to Simpson's integration rule) is as follows:

$$A_{V,AA} = \frac{A_3 \cdot A_2}{3} \cdot (V_{d3} + 4 \cdot V_{d2} + V_{d1}) = 21,63$$

With reference to Fig 7 and Fig 8 the following areas are calculated:

- area $A_{1A_3C_3G_1}$ (which is the area $A_{V,AA}$ calculated above), in m^2 , equal to: 21,63
- topside tank area A_W , in m^2 , equal to: 13,98
- area $A_{V,I}$, in m^2 , relevant to void I, equal to:
 $A_{V,I} = 21,63 - 13,98 = 7,65$
- area $A_{V,II}$, in m^2 , relevant to void II, equal to:
 $A_{V,II} = 5 \cdot 2,91 = 14,55$
- total area $A_{T,AA}$ of void, port and starboard, in m^2 , in section AA, equal to:
 $A_{T,AA} = 2 (7,65 + 14,55) = 44,40$

With the same procedure the void relevant to the BB section is calculated, as follows:

- total area $A_{T,BB}$ of void, port and starboard, in m^2 , in section BB:
 $A_{T,BB} = 22,98$
- total area $A_{T,CC}$ of void, port and starboard, in m^2 , in section CC:
 $A_{T,CC} = 2 (5 \cdot 0,60) = 6,00$

Figure 6 : Geometry for void depth calculation

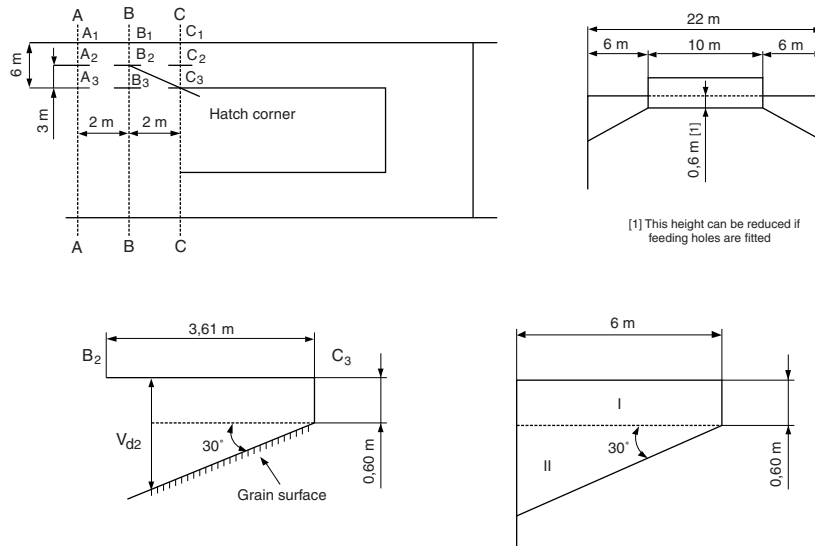

Figure 7 : Geometry for void depth calculation

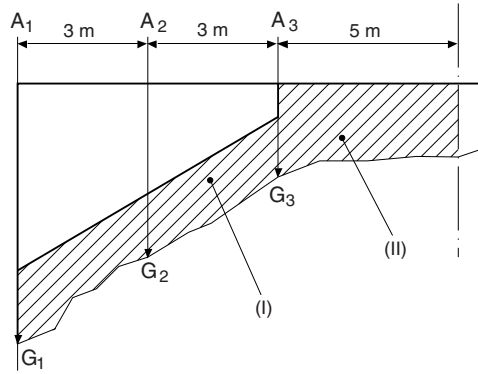
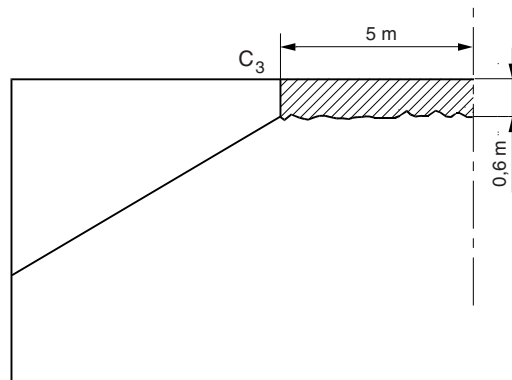

Figure 8 : Geometry for void depth calculation



2.1.4 Calculation of areas and area moments

Finding the surface at each station after shift which establishes a void area exactly equal to that at the station before shift is a complicated calculation if done directly.

However, if the areas and corresponding area moments are calculated for random shifts from the horizontal to 25°, and a plot is made of areas versus area moments, then by entering the plot with the actual void area at any position before shift, a close approximation to the area moment after shift can be obtained. Such a plot is provided in Fig 9.

Another advantage of this method lies in the fact that while the lengths of the end sections may vary, the cross-sectional dimensions are usually uniform throughout most of the ship. Therefore the same plot of areas versus area moments can be used for several locations.

Figure 9 : Plot of areas versus area moments

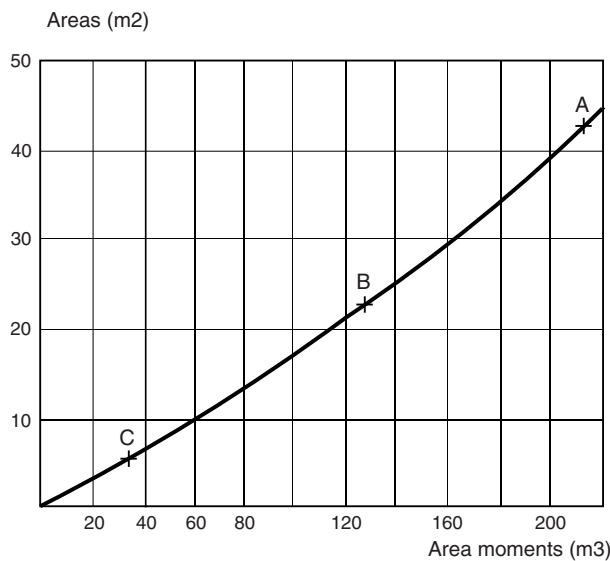

With reference to Fig 10, the areas relevant to the zones 1, 2, 3 are as follows:

- area A_1 , in m^2 , relevant to zone 1:

$$A_1 = \frac{8,74(\tan 25^\circ)8,74}{2} - 13,98 = 3,83$$

- area A_2 , in m^2 , relevant to zone 2:

$$A_2 = \frac{13(\tan 25^\circ)13}{2} - 13,98 = 25,41$$

- area A_3 , in m^2 , relevant to zone 3:

$$A_3 = \frac{16(\tan 25^\circ)16}{2} - 13,98 = 45,70$$

Figure 10 : Geometry for void depth calculation

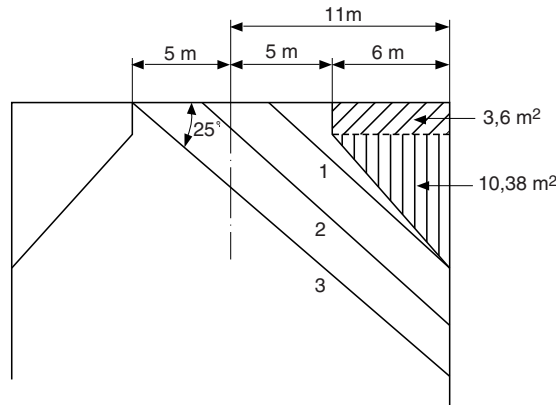

The area moments M_1 , M_2 , M_3 , in m^3 , relevant to areas A_1 , A_2 , A_3 , referred to the centreline are as follows:

- area moment M_1 :

$$M_1 = 17,81\left(\frac{2}{3} \cdot 8,74 + 2,26\right) - 3,6(3 + 5) - 10,38\left(\frac{2}{3} \cdot 6 + 5\right) = 21,80$$

- area moment M_2 :

$$M_2 = 39,39\left(\frac{2}{3} \cdot 13 - 2\right) - 3,6(3 + 5) - 10,38\left(\frac{2}{3} \cdot 6 + 5\right) = 140,38$$

- area moment M_3 :

$$M_3 = 59,68\left(\frac{2}{3} \cdot 16 - 5\right) - 3,6(3 + 5) - 10,38\left(\frac{2}{3} \cdot 6 + 5\right) = 215,97$$

A summary of the values obtained is reported in Tab 3.

Table 3 : Areas and area moments

Zone	Area, in m^2	Area moment in m^3
1	3,83	21,80
2	25,41	140,38
3	45,70	215,97

2.1.5 Calculation of volumetric heeling moment

- a) Volumetric heeling moment in untrimmed end

Tab 4 gives the values of areas and area moments derived from the plot in Fig 9.

Therefore, the longitudinal distance between points A, B, C being equal to 2 m, the volumetric heeling moment in the untrimmed end M^I , in m^4 , is as follows:

$$M^I = \frac{2}{3}[1 \cdot 34 + 4 \cdot 128 + 1 \cdot 212] = 505,33$$

b) Volumetric heeling moment in hatch

The following calculation is valid for void spaces within the hatch (see Fig 11):

- void area A_H , in m^2 :

$$A_H = 10(0,4 + 0,15) = 5,5$$

- centre of gravity x , in m, relevant to A_H :

$$x = \frac{\sqrt{5,5 \cdot 2}}{\tan 15^\circ} = 6,41$$

- area moment M_H , in m^3 :

$$M_H = 5,5 \left(5 - \frac{6,41}{3} \right) = 15,75$$

The hatch length being equal to 15 m, the volumetric heeling moment in hatch M^H , in m^4 , is as follows:

$$M^H = 17,75 \cdot 15 = 236,25$$

In addition, the possible void relevant to a longitudinal deck girder as described in Fig 12, as well as the possible void relevant to the topside tank geometry as described in Fig 13, are to be taken into account; on the contrary, the possible void relevant to topside tank longitudinal stiffeners as described in Fig 14 may not be taken into account.

c) Volumetric heeling moment

The total volumetric heeling moment in a hold, as reported in Tab 4, is the sum of the contribution of a) and b) above.

Figure 11 : Volumetric heeling moment in hatch

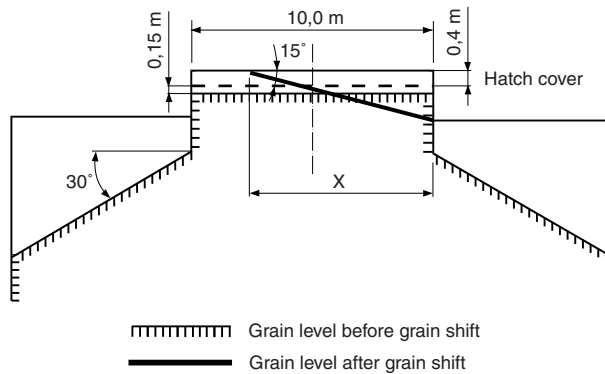

Figure 12 : Possible void relevant to a longitudinal deck girder

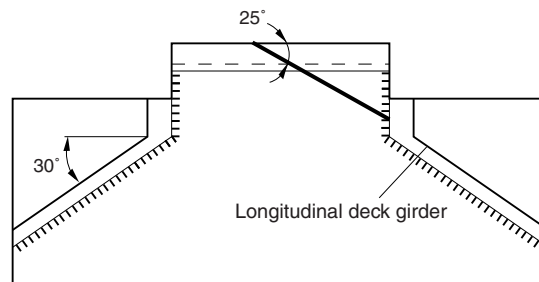

Figure 13 : Possible void relevant to the topside tank geometry

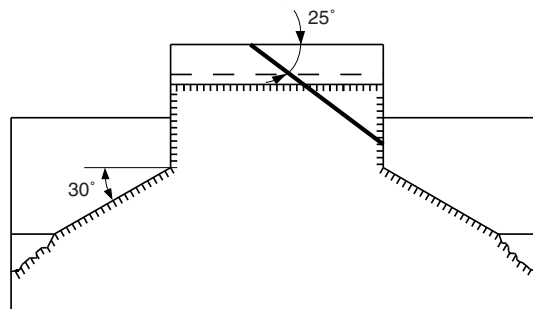

Figure 14 : Possible void relevant to topside tank longitudinal stiffeners

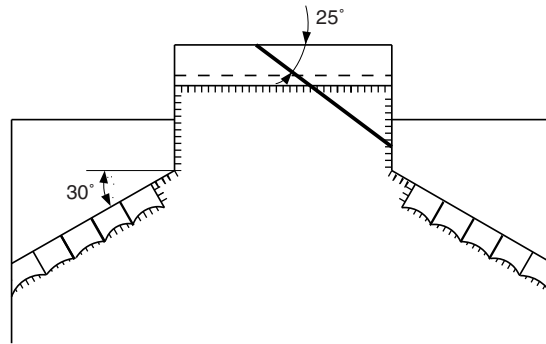

Table 4 : Total volumetric heeling moment in a hold, with untrimmed ends

Hold zone	Heeling moment, in m ⁴
Fore end	505,33
Hatch	236,25
Aft end	505,33
Total	1246,91

Appendix 2 Hold Mass Curves

Symbols

h	: Vertical distance from the top of inner bottom plating to the lowest point of the upper deck plating at the ship's centreline, in m
h_a	: Vertical distance from the top of inner bottom plating to the lowest point of the upper deck plating at the ship's centreline of the aft cargo hold of two adjacent cargo holds, in m
h_f	: Vertical distance from the top of inner bottom plating to the lowest point of the upper deck plating at the ship's centreline of the fore cargo hold of two adjacent cargo holds, in m
M_H	: Cargo mass, in t, as defined in Pt B, Ch 5, Sec 6.
M_{Full}	: Cargo mass, in t, as defined in Pt B, Ch 5, Sec 6.
M_{HD}	: Cargo mass, in t, as defined in Pt B, Ch 5, Sec 6
M_{BLK}	: The maximum cargo mass in a cargo hold of two adjacent cargo holds according to the block loading condition in the loading manual, in t
T_i	: In loading condition No. i, draught, in m, at mid-hold position of single cargo hold length or at mid-length of the two adjacent cargo holds considered
T_{min}	: 0,75 T_{SC} or draught in ballast conditions with the two adjacent cargo holds empty, whichever is greater, in m
T_{H1}	: Minimum permissible draught, in m, in harbour condition with M_{Full} in each of the two adjacent holds to be taken as defined in Tab 1
T_{H2}	: Minimum permissible draught, in m, in harbour condition with M_{Full} in holds intended to be empty in alternate loading conditions or in any hold of ships always loaded homogeneously, to be taken as defined in Tab 1
T_{H3}	: Minimum permissible draught, in m, in harbour condition in case of block loading with M_{BLK} in each of the two adjacent holds of ships intended to be loaded in alternate conditions, to be taken as defined in Tab 1
T_{H4}	: Minimum permissible draught, in m, in harbour condition with M_{HD} in holds intended to be full in alternate conditions, to be taken as defined in Tab 1
V_H	: Volume in m^3 , as defined in Pt B, Ch 5, Sec 6
V_a	: Volume of the after cargo hold of two adjacent cargo holds excluding volume of the hatchway part, in m^3
V_f	: Volume of the forward cargo hold of two adjacent cargo holds excluding volume of the hatchway part, in m^3
Σ	: The sum of masses of two adjacent cargo holds.

1 General

1.1 Application

1.1.1 The requirements of this Appendix apply to bulk carriers of 150 m in length L and above.

1.1.2 This appendix describes the procedure to be used for determination of:

- The maximum and minimum mass of cargo in each cargo hold as a function of the draught at mid-hold position of cargo hold.
- The maximum and minimum mass of cargo in any two adjacent holds as a function of the draught at mid-length of these two adjacent cargo holds.

Results of these calculations are to be included in the reviewed Loading Manual which has also to indicate the maximum permissible mass of cargo at scantling draught in each hold or in any two adjacent holds, as obtained from the design review.

1.1.3 General

The cargo mass curves of single cargo hold or of two adjacent cargo holds in seagoing and harbour conditions as defined in Tab 2 to Tab 9 are based on the loading conditions considered in Ch 4, Sec 3, [3.3]. However if the ship structure is checked for more severe loading conditions, the minimum required cargo mass and the maximum allowable cargo mass can be based on those corresponding loading conditions.

1.1.4 Loading/unloading conditions in harbour

For any bulk carrier, the maximum permissible cargo mass and the minimum required cargo mass of single cargo hold or of two adjacent cargo holds, corresponding to draught for loading/unloading conditions in harbour may be increased or decreased by 15% of the maximum permissible mass at the maximum draught for the cargo hold in seagoing condition. However, maximum permissible mass is in no case to be greater than the maximum permissible cargo mass at designed maximum load draught for each cargo hold.

1.1.5 Maximum and minimum permissible mass expression

The maximum and minimum permissible mass in seagoing conditions, ($W_{\max}(T_i)$, $W_{\min}(T_i)$) and in harbour condition ($W_{\max H}(T_i)$, $W_{\min H}(T_i)$) at various draughts (T_i) are obtained, in t, by the following formulae given in Tab 2 to Tab 9 for the followings cases:

- ships intended to be loaded in alternate conditions not completed by the **(No MP)** indication
- ships intended to be loaded in alternate conditions completed by the **(No MP)** indication
- ships always loaded homogeneously not completed by the **(No MP)** indication
- ships always loaded homogeneously completed by the **(No MP)** indication.

2 Hold mass curves

2.1 General

2.1.1 Maximum permissible mass and minimum required mass of single cargo hold

See Tab 2 to Tab 5.

2.1.2 Maximum permissible mass and minimum required mass of two adjacent holds

See Tab 6 to Tab 9.

Table 1 : Minimum permissible draught, in m

	For ships having (No MP) notation assigned	For ships not having (No MP) notation assigned
T_{H1}	$T_{H1} = \min \left\{ \begin{array}{l} 0,67T_{SC} \\ T_{SC} - \frac{0,15 \sum M_{Full}}{1,025 \left(\frac{V_f}{h_f} + \frac{V_a}{h_a} \right)} \end{array} \right.$	$T_{H2} = 0,67T_{SC} - \frac{0,15M_{Full}}{1,025 \frac{V_H}{h}}$
T_{H2}	$T_{H2} = \min \left\{ \begin{array}{l} 0,67T_{SC} \\ T_{SC} - \frac{0,15M_{Full}}{1,025 \frac{V_H}{h}} \end{array} \right.$	$T_{H2} = 0,67T_{SC} - \frac{0,15M_{Full}}{1,025 \frac{V_H}{h}}$
T_{H3}	$T_{H3} = T_{SC} - \frac{\sum (0,15M_{BLK} + 0,1M_H)}{1,025 \left(\frac{V_f}{h_f} + \frac{V_a}{h_a} \right)}$	
T_{H4}	$T_{H4} = \min \left\{ \begin{array}{l} 0,67T_{SC} \\ T_{SC} - \frac{0,15M_{HD} + 0,1M_H}{1,025 \frac{V_H}{h}} \end{array} \right.$	

Table 2 : Ships intended to be loaded in alternate conditions not having {No MP} notation assigned

Hold	Loading conditions	Max / Min curves	Curve Ref
Full	Seagoing	Maximum: $W_{\max S}(T_i) = M_{HD} + 0,1 M_H - 1,025 V_H \frac{(T_{SC} - T_i)}{h} \leq M_{HD}$	I
		Minimum: $W_{\min S}(T_i) = 1,025 V_H \frac{(T_i - 0,83 T_{SC})}{h} \geq 0$	II
	Harbour	Maximum: $W_{\max H}(T_i) = \max \left\{ \begin{array}{l} M_{HD} - 1,025 V_H \frac{(0,67 T_{SC} - T_i)}{h} \leq M_{HD} \\ W_{\max S}(T_i) + 0,15 M_{HD} \leq M_{HD} \end{array} \right.$	III-1 III-2
		Minimum: $W_{\min H}(T_i) = W_{\min S}(T_i) - 0,15 M_{HD} \geq 0$	IV
Empty	Seagoing	Maximum: $W_{\max S}(T_i) = M_{Full} - 1,025 V_H \frac{(0,67 T_{SC} - T_i)}{h} \leq M_{Full}$	I
		Minimum: $W_{\min S}(T_i) = 1,025 V_H \frac{(T_i - T_{SC})}{h} \geq 0$	II
	Harbour	Maximum: $W_{\max H}(T_i) = W_{\max S}(T_i) + 0,15 M_{Full} \leq M_{Full}$	III
		Minimum: $W_{\min H}(T_i) = W_{\min S}(T_i) - 0,15 M_{Full} \geq 0$	IV

Table 3 : ships intended to be loaded in alternate conditions having {No MP} notation assigned

Hold	Loading conditions	Max / Min curves	Curve Ref	
Full	Seagoing	Maximum:	$W_{\max S}(T_i) = M_{HD} + 0,1 M_H - 1,025 V_H \frac{(T_{SC} - T_i)}{h} \leq M_{HD}$	I
		Minimum:	$W_{\min S}(T_i) = \min \begin{cases} 1,025 V_H \frac{(T_i - T_{BAL-H})}{h} \geq 0 \\ 0,5 M_H - 1,025 V_H \frac{(T_{SC} - T_i)}{h} \geq 0 \end{cases}$	II-1 II-2
	Harbour	Maximum:	$W_{\max H}(T_i) = \max \begin{cases} M_{HD} - 1,025 V_H \frac{(0,67 T_{SC} - T_i)}{h} \leq M_{HD} \\ W_{\max S}(T_i) + 0,15 M_{HD} \leq M_{HD} \end{cases}$	III-1 III-2
		Minimum:	$W_{\min H}(T_i) = W_{\min S}(T_i) - 0,15 M_{HD} \geq 0$	IV
Empty	Seagoing	Maximum:	$W_{\max S}(T_i) = M_{Full} - 1,025 V_H \frac{(T_{SC} - T_i)}{h} \leq M_{Full}$	I
		Minimum:	$W_{\min S}(T_i) = 1,025 V_H \frac{(T_i - T_{SC})}{h} \geq 0$	II
	Harbour	Maximum:	$W_{\max H}(T_i) = \max \begin{cases} M_{Full} - 1,025 V_H \frac{(0,67 T_{SC} - T_i)}{h} \leq M_{Full} \\ W_{\max S}(T_i) + 0,15 M_{Full} \leq M_{Full} \end{cases}$	III-1 III-2
		Minimum:	$W_{\min H}(T_i) = W_{\min S}(T_i) - 0,15 M_{Full} \geq 0$	IV

Table 4 : ships always loaded homogeneously not having {No MP} notation assigned

Loading conditions	Max / Min curves		Curve Ref
Seagoing	Maximum:	$W_{\max S}(T_i) = M_{\text{Full}} - 1,025 V_H \frac{(0,67 T_{SC} - T_i)}{h} \leq M_{\text{Full}}$	I
	Minimum:	$W_{\min S}(T_i) = 1,025 V_H \frac{(T_i - 0,83 T_{SC})}{h} \geq 0$	II
Harbour	Maximum:	$W_{\max H}(T_i) = W_{\max S}(T_i) + 0,15 M_{\text{Full}} \leq M_{\text{Full}}$	III
	Minimum:	$W_{\min H}(T_i) = W_{\min S}(T_i) - 0,15 M_{\text{Full}} \geq 0$	IV

Table 5 : ships always loaded homogeneously having {No MP} notation assigned

Loading conditions	Max / Min curves		Curve Ref
Seagoing	Maximum:	$W_{\max S}(T_i) = M_{\text{Full}} - 1,025 V_H \frac{(T_{SC} - T_i)}{h} \leq M_{\text{Full}}$	I
	Minimum:	$W_{\min S}(T_i) = \min \left\{ \begin{array}{l} 1,025 V_H \frac{(T_i - T_{BAL-H})}{h} \geq 0 \\ 0,5 M_H - 1,025 V_H \frac{(T_{SC} - T_i)}{h} \geq 0 \end{array} \right.$	II-1 II-2
Harbour	Maximum:	$W_{\max H}(T_i) = \max \left\{ \begin{array}{l} M_{\text{Full}} - 1,025 V_H \frac{(0,67 T_{SC} - T_i)}{h} \leq M_{\text{Full}} \\ W_{\max S}(T_i) + 0,15 M_{\text{Full}} \leq M_{\text{Full}} \end{array} \right.$	III-1 III-2
	Minimum:	$W_{\min H}(T_i) = W_{\min S}(T_i) - 0,15 M_{\text{Full}} \geq 0$	IV

Table 6 : ships intended to be loaded in alternate conditions not having {No MP} notation assigned

Loading conditions	Max / Min curves	Curve Ref
Seagoing	Maximum: $W_{\max S}(T_i) = \max \left\{ \begin{aligned} &\sum (M_{BLK} + 0,1 M_H) - 1,025 \left(\frac{V_f}{h_f} + \frac{V_a}{h_a} \right) (T_{SC} - T_i) \leq \sum M_{BLK} \\ &\sum M_{Full} - 1,025 \left(\frac{V_f}{h_f} + \frac{V_a}{h_a} \right) (0,67 T_{SC} - T_i) \leq \sum M_{Full} \end{aligned} \right.$	I-1 (1) I-2
	Minimum: $W_{\min S}(T_i) = 1,025 \left(\frac{V_f}{h_f} + \frac{V_a}{h_a} \right) (T_i - 0,75 T_{SC}) \geq 0$	II
Harbour	Maximum: $W_{\max H}(T_i) = \max \left\{ \begin{aligned} &W_{\max S}(T_i) + 0,15 \sum M_{BLK} \leq \sum M_{BLK} \\ &W_{\max S}(T_i) + 0,15 \sum M_{Full} \leq \sum M_{Full} \end{aligned} \right.$	III-1 (1) III-2
	Minimum: $W_{\min H}(T_i) = \min \left\{ \begin{aligned} &W_{\min S}(T_i) - 0,15 \sum M_{BLK} \geq 0 \\ &W_{\min S}(T_i) - 0,15 \sum M_{Full} \geq 0 \end{aligned} \right.$	IV-1 (1) IV-2

(1) This limit curve is only applicable when block loading condition is included in the loading manual.

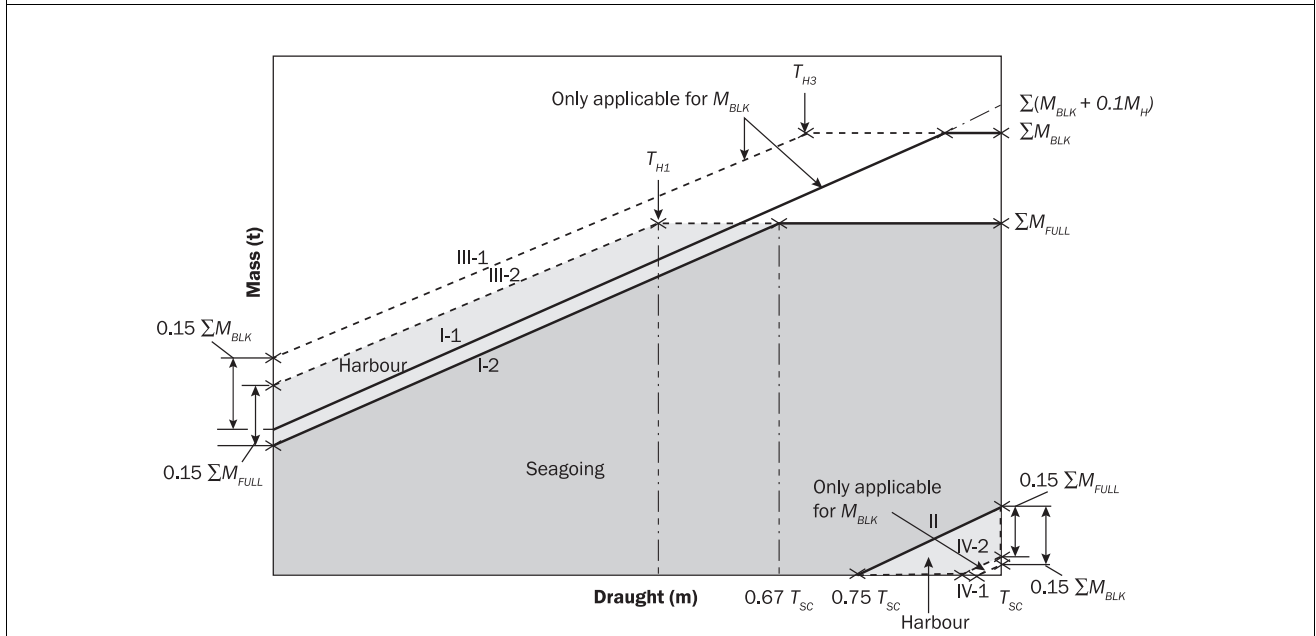

Table 7 : ships intended to be loaded in alternate conditions having {No MP} notation assigned

Loading conditions	Max / Min curves	Curve Ref
Seagoing	Maximum: $W_{\max S}(T_i) = \max \begin{cases} \sum (M_{BLK} + 0,1 M_H) - 1,025 \left(\frac{V_f}{h_f} + \frac{V_a}{h_a} \right) (T_{SC} - T_i) \leq \sum M_{BLK} \\ \sum M_{Full} - 1,025 \left(\frac{V_f}{h_f} + \frac{V_a}{h_a} \right) (T_{SC} - T_i) \leq \sum M_{Full} \end{cases}$	I-1 (1) I-2
	Minimum: $W_{\min S}(T_i) = \min \begin{cases} 1,025 \left(\frac{V_f}{h_f} + \frac{V_a}{h_a} \right) (T_i - T_{BAL-H}) \geq 0 \\ 0,5 \sum M_H - 1,025 \left(\frac{V_f}{h_f} + \frac{V_a}{h_a} \right) (T_{SC} - T_i) \geq 0 \end{cases}$	II-1 II-2
Harbour	Maximum: $W_{\max H}(T_i) = \max \begin{cases} W_{\max S}(T_i) + 0,15 \sum M_{BLK} \leq \sum M_{BLK} \\ \sum M_{Full} - 1,025 \left(\frac{V_f}{h_f} + \frac{V_a}{h_a} \right) (0,67 T_{SC} - T_i) \leq \sum M_{Full} \\ W_{\max S}(T_i) + 0,15 \sum M_{Full} \leq \sum M_{Full} \end{cases}$	III-1 (1) III-2 III-3
	Minimum: $W_{\min H}(T_i) = \min \begin{cases} W_{\min S}(T_i) - 0,15 \sum M_{BLK} \geq 0 \\ W_{\min S}(T_i) - 0,15 \sum M_{Full} \geq 0 \end{cases}$	IV-1 (1) IV-2

(1) This limit curve is only applicable when block loading condition is included in the loading manual.

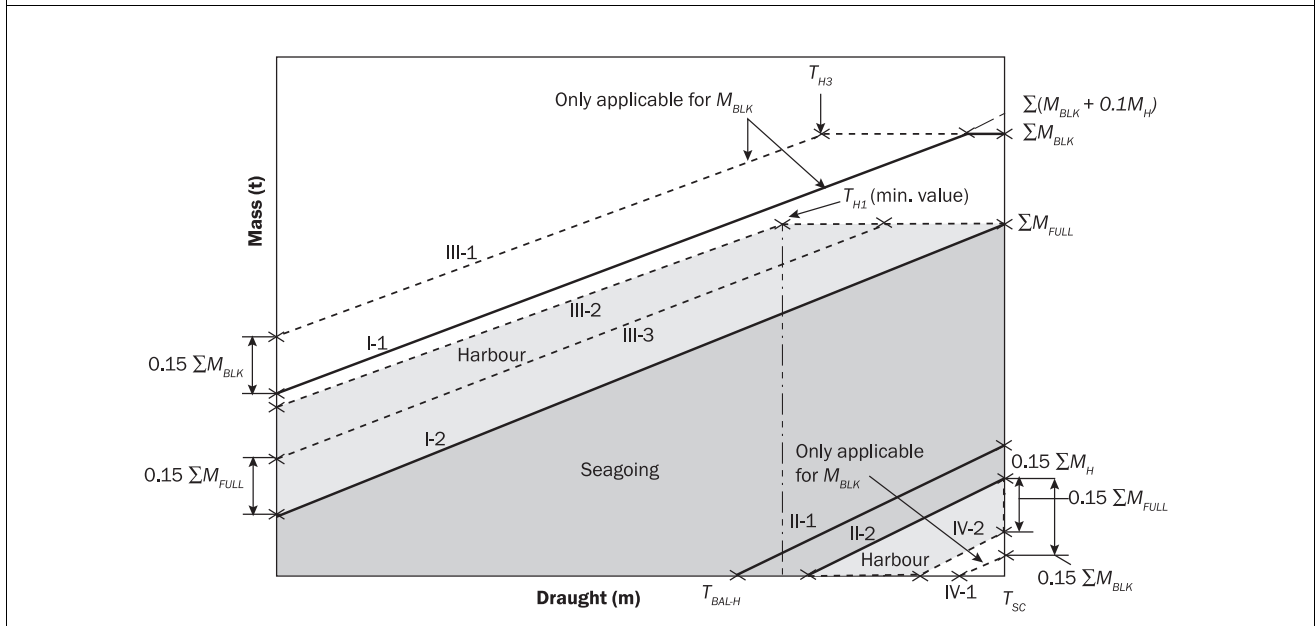
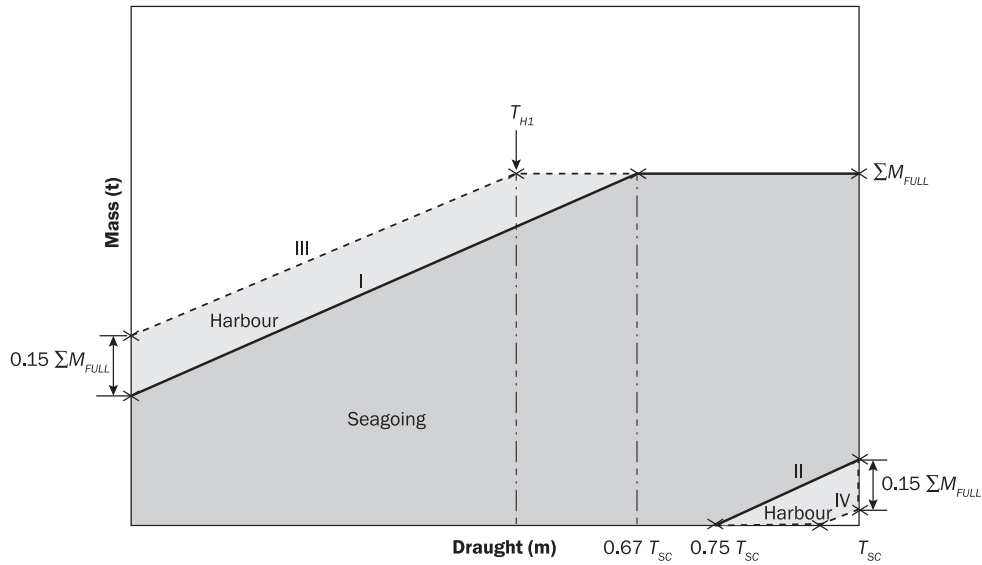

Table 8 : ships always loaded homogeneously not having {No MP} notation assigned

Loading conditions	Max / Min curves	Curve Ref
Seagoing	Maximum: $W_{\max S}(T_i) = \sum M_{Full} - 1,025 \left(\frac{V_f}{h_f} + \frac{V_a}{h_a} \right) (0,67 T_{SC} - T_i) \leq \sum M_{Full}$	I
	Minimum: $W_{\min S}(T_i) = 1,025 \left(\frac{V_f}{h_f} + \frac{V_a}{h_a} \right) (T_i - 0,75 T_{SC}) \geq 0$	II
Harbour	Maximum: $W_{\max H}(T_i) = W_{\max S}(T_i) + 0,15 \sum M_{Full} \leq \sum M_{Full}$	III
	Minimum: $W_{\min H}(T_i) = W_{\min S}(T_i) - 0,15 \sum M_{Full} \geq 0$	IV



Part D

Service Notations

CHAPTER 5

ORE CARRIERS

- Section 1 General
- Section 2 Ship Arrangement
- Section 3 Hull and Stability

Section 1 General

1 General

1.1 Application

1.1.1 Ships complying with the requirements of this Chapter are eligible for the assignment of the service notation **ore carrier**, as defined in Pt A, Ch 1, Sec 2, [4.3.3].

1.1.2 Ships dealt with in this Chapter are to comply with:

- Part A of the Rules
- NR216 Materials and Welding
- Tab 1.

Table 1 : Applicable requirements

Item		Greater than or equal to 500 GT	Less than 500 GT
Ship arrangement	L ≥ 65 m	<ul style="list-style-type: none"> • Part B • Ch 5, Sec 2 	<ul style="list-style-type: none"> • NR566 • Ch 5, Sec 2
	L < 65 m	<ul style="list-style-type: none"> • NR600 	<ul style="list-style-type: none"> • NR566 • Ch 5, Sec 2
Hull	L ≥ 65 m	<ul style="list-style-type: none"> • Part B • Ch 5, Sec 3 	<ul style="list-style-type: none"> • Part B • Ch 5, Sec 3
	L < 65 m	<ul style="list-style-type: none"> • NR600 	<ul style="list-style-type: none"> • NR600
Stability		<ul style="list-style-type: none"> • Part B • Ch 5, Sec 3 	<ul style="list-style-type: none"> • NR566 • Ch 5, Sec 3
Machinery and cargo systems		<ul style="list-style-type: none"> • Part C 	<ul style="list-style-type: none"> • NR566
Electrical installations		<ul style="list-style-type: none"> • Part C 	<ul style="list-style-type: none"> • NR566
Automation		<ul style="list-style-type: none"> • Part C 	<ul style="list-style-type: none"> • NR566
Fire protection, detection and extinction		<ul style="list-style-type: none"> • Part C 	<ul style="list-style-type: none"> • NR566
<p>Note 1: NR566: Hull Arrangement, Stability and Systems for Ships less than 500 GT. NR600: Hull Structure and Arrangement for the Classification of Cargo Ships less than 65 m and Non Cargo Ships less than 90 m.</p>			

Section 2 Ship Arrangement

1 General

1.1 Application

1.1.1 The requirements of Ch 5, Sec 2 and Ch 5, Sec 3 apply to single deck ships with two longitudinal bulkheads and a double bottom throughout the cargo region and intended to carry dry cargoes in bulk, including ore cargo, in the centre holds only. A typical midship section is shown in Fig 1.

The application of these requirements to other ship types is to be considered by the Society on a case-by-case basis.

Figure 1 : Ore carrier

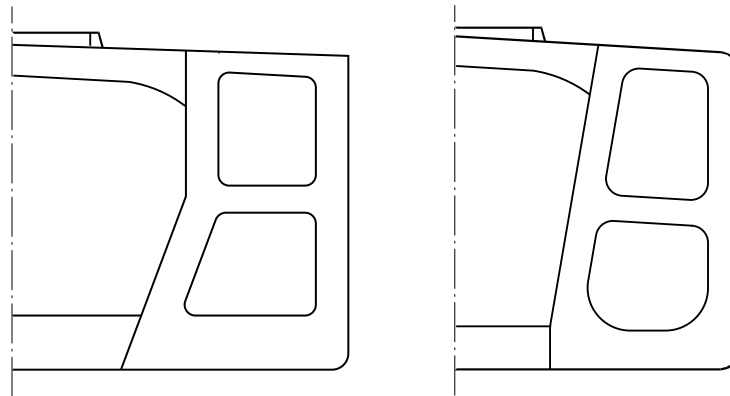

2 General arrangement design

2.1 General

2.1.1 Forecastle

Ships with the service notation **ore carrier ESP** are to be fitted with an enclosed forecastle on the freeboard deck, with its aft bulkhead fitted in way or aft of the forward bulkhead of the foremost hold, as shown in Fig 2.

However, if this requirement hinders hatch cover operation, the aft bulkhead of the forecastle may be fitted forward of the forward bulkhead of the foremost cargo hold provided the forecastle length is not less than 7% of ship length abaft the forward perpendicular where the ship length and forward perpendicular are defined in the International Convention on Load Lines 1966 and its Protocol 1988.

Figure 2 : Forecastle arrangement

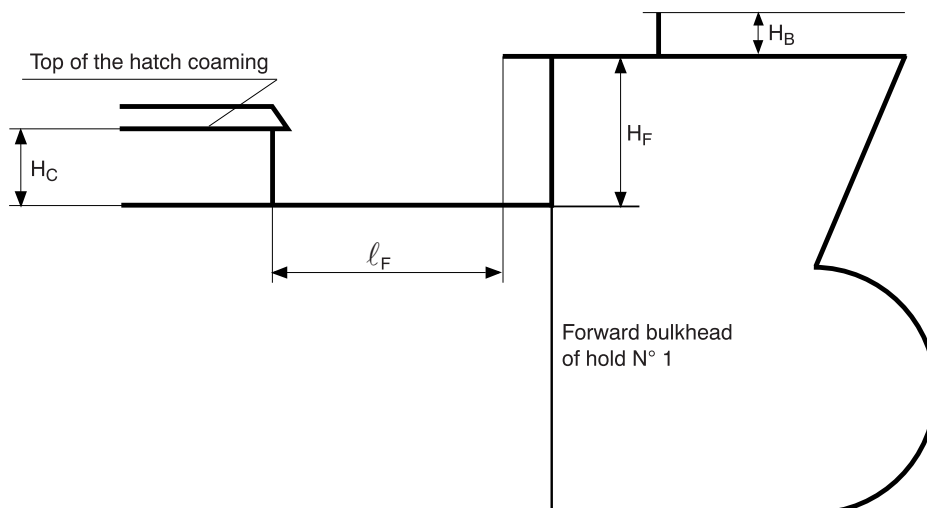

The forecastle height H_F above the main deck is to be not less than:

- the standard height of a superstructure as specified in Pt B, Ch 1, Sec 3, [2.2]
- $H_C + 0,5$ m, where H_C is the height of the forward transverse hatch coaming of the foremost cargo hold, i.e. cargo hold No. 1, whichever is the greater.

All points of the aft edge of the forecastle deck are to be located at a distance ℓ_F :

$$\ell_F \leq 5\sqrt{H_F - H_C}$$

from the hatch coaming plate in order to apply the reduced loading to the No. 1 forward transverse hatch coaming and No. 1 hatch cover in applying Pt B, Ch 11, Sec 9, [4.1.3], and Pt B, Ch 11, Sec 9, [8.3.9].

A breakwater is not to be fitted on the forecastle deck with the purpose of protecting the hatch coaming or hatch covers. If fitted for other purposes, it is to be located such that its upper edge at centre line is not less than $H_B / \tan 20^\circ$ forward of the aft edge of the forecastle deck, where H_B is the height of the breakwater above the forecastle (see Fig 2).

3 Access arrangement

3.1 Access arrangement to double bottom and pipe tunnel

3.1.1 Means of access

Adequate means of access to the double bottom and pipe tunnel are to be provided.

3.1.2 Manholes in the inner bottom, floors and girders

Manholes cut in the inner bottom are to be located at a minimum distance of one floor spacing from the lower stool.

The location and size of manholes in floors and girders are to be determined to facilitate the access to double bottom structures and their ventilation. However, they are to be avoided in the areas where high shear stresses may occur.

3.2 Access arrangement to and within spaces in, and forward of, the cargo area

3.2.1 Means of access

Ships with the service notation **ore carrier ESP**, of 20,000 gross tonnage and over, are to comply with the International Convention for the Safety of Life at Sea, 1974, as amended, Chapter II-1, Part A-1, Regulation 3-6, for details and arrangements of openings and attachments to the hull structure.

Ships with the service notation **ore carrier ESP**, of less than 20,000 gross tonnage, are to comply with [3.2.2] and [3.2.3]. In addition, as far as practicable, permanent or movable means of access stored on board are to be provided to ensure proper survey and maintenance of cargo holds.

3.2.2 Hatches of large cargo holds

If separate hatches are used as access to the ladders as required in [3.2.3], each hatch is to have a clear opening of at least 600 mm x 600 mm.

When the access to the cargo hold is arranged through the cargo hatch, the top of the ladder is to be placed as close as possible to the hatch coaming.

Accesses and ladders are to be so arranged that personnel equipped with self-contained breathing apparatus may readily enter and leave the cargo hold.

Access hatch coamings having a height greater than 900 mm are also to have steps on the outside in conjunction with cargo hold ladders.

3.2.3 Ladders within large cargo holds

Each cargo hold is to be provided with at least two ladders as far apart as practicable longitudinally. If possible these ladders are to be arranged diagonally, e.g. one ladder near the forward bulkhead on the port side, the other one near the aft bulkhead on the starboard side, from the ship's centreline.

Ladders are to be so designed and arranged that the risk of damage from the cargo handling gear is minimised.

Vertical ladders may be permitted provided they are arranged above each other in line with other ladders to which they form access and resting positions are provided at not more than 9 metres apart.

Tunnels passing through cargo holds are to be equipped with ladders or steps at each end of the hold so that personnel may get across such tunnels.

Where it may be necessary for work to be carried out within a cargo hold preparatory to loading, consideration is to be given to suitable arrangements for the safe handling of portable staging or movable platforms.

Section 3 Hull and Stability

Symbols

- R_{eH} : Minimum yield stress, in N/mm², of the material
 k : Material factor for steel, defined in Pt B, Ch 4, Sec 1, [2.2]
 E : Young's modulus, in N/mm², to be taken equal to:
 - $E = 2,06 \cdot 10^5$ N/mm² for steels in general
 - $E = 1,95 \cdot 10^5$ N/mm² for stainless steels. b : Breadth of plate panel, in mm, as defined in Pt B, Ch 4, Sec 6, [2.1.1].

1 General

1.1 Loading manual and loading instruments

1.1.1 The specific requirements in Pt B, Ch 1, Sec 5 for ships with the service notation **ore carrier ESP** and equal to or greater than 150 m in length are to be complied with.

2 Stability

2.1 Intact stability

2.1.1 General

The stability of the ship for the loading conditions in Pt B, Ch 3, App 2, [1.2.5] is to be in compliance with the requirements in Pt B, Ch 3, Sec 2. Where the ship is intended also for the carriage of grain, the requirements in Ch 4, Sec 3, [1.2.2] and Ch 4, Sec 3, [1.2.3] are to be complied with.

2.2 Damage stability requirements for ships where additional class notation SDS has been required

2.2.1 General

Ore carriers equal to or greater than 80 m in length are subjected to the probabilistic approach reported in Pt B, Ch 3, Sec 3, [2.1.3] and are to comply with the requirements in Pt B, Ch 3, App 3.

2.2.2 Freeboard reduction

Ore carriers greater than 100 m in length which have been assigned reduced freeboard as permitted by Regulation 27 of the International Convention on Load Lines, 1966, as referenced in Pt B, Ch 3, Sec 3, [2.1.2] are to comply with the requirement specified in Pt B, Ch 3, App 4. Therefore, compliance with the requirements in [2.2.1] is not required.

3 Structure design principles

3.1 Double bottom structure

3.1.1 The double bottom is to be longitudinally framed.

The girder spacing is to be not greater than 4 times the spacing of bottom or inner bottom ordinary stiffeners and the floor spacing is to be not greater than 3 frame spaces.

Solid floors are to be fitted in line with the transverse primary supporting members in wing tanks and intermediate floors are to be added at mid-span between primary supporting members.

3.1.2 Other arrangements may be accepted by the Society, on a case-by-case basis, depending on the results of the analysis carried out according to Pt B, Ch 8, Sec 1 for the primary supporting members in the cargo holds.

3.1.3 Scarfing of the double bottom structure into the wing tanks is to be properly ensured. The inner bottom plating is generally to be prolonged within the wing tanks by adequately sized horizontal brackets in way of floors.

3.2 Side structure

3.2.1 In ships greater than 120 m in length, the side shell is to be longitudinally framed.

In general, the spacing of vertical primary supporting members is to be not greater than 6 times the frame spacing.

3.2.2 Other arrangements may be accepted by the Society, on a case-by-case basis, depending on the results of the analysis carried out according to Pt B, Ch 8, Sec 1 for the primary supporting members in the cargo hold.

3.3 Deck structure

3.3.1 The deck outside the line of hatches is to be longitudinally framed.

3.3.2 The cross decks between hatches are generally to be transversely framed.

3.3.3 The connection of hatch end beams with deck structures is to be properly ensured by fitting inside the wing tanks additional web frames or brackets.

3.4 Longitudinal bulkhead structure

3.4.1 Longitudinal bulkheads are to be plane, but they may be knuckled in the upper and lower parts to form a hopper. In such cases, the design of the knuckles and the adjacent structures is to be considered by the Society on a case-by-case basis.

3.4.2 In ships greater than 120 m in length, longitudinal bulkheads are to be longitudinally framed.

3.4.3 Other arrangements may be accepted by the Society, on a case-by-case basis, depending on the results of the analysis carried out according to Pt B, Ch 8, Sec 1 for the primary supporting members in the cargo hold.

3.5 Transverse bulkhead structure

3.5.1 Where the structural arrangement of transverse bulkheads in wing tanks is different from that in centre holds, arrangements are to be made to ensure continuity of the transverse strength through the longitudinal bulkheads.

4 Design loads

4.1 Hull girder loads

4.1.1 Still water loads

In addition to the requirements in Pt B, Ch 5, Sec 4, [2.1.1], still water loads are to be calculated for the following loading conditions, subdivided into departure and arrival conditions as appropriate:

- alternate light and heavy cargo loading conditions at maximum draught
- homogeneous light and heavy cargo loading conditions at maximum draught
- ballast conditions. Partial filling of the peak tanks is not acceptable in the design ballast conditions, unless effective means are provided to prevent accidental overfilling.
- short voyage conditions where the ship is to be loaded to maximum draught but with a limited amount of bunkers
- Multi-port (MP) loading/unloading conditions, if allowed by the loading manual (see definition in Pt B, Ch 1, Sec 3, [2.6.1])
- deck cargo conditions, where applicable
- typical loading sequences where the ship is loaded from commencement of cargo loading to reaching full deadweight capacity, for homogeneous conditions, relevant part load conditions and alternate conditions where applicable. Typical unloading sequences for these conditions are also to be included. The typical loading/unloading sequences are also to be developed so as not to exceed applicable strength limitations. The typical loading sequences are also to be developed paying due attention to the loading rate and deballasting capability.
- typical sequences for change of ballast at sea, where applicable.

4.2 Load combinations for direct strength analysis

4.2.1 The following sea-going loading conditions are to be considered for direct strength analysis:

- full load and scantling draught T , the loaded holds being completely filled with cargo
- full load, the cargo density being the maximum obtained from the loading booklet, but taken not less than 3 t/m^3 , and scantling draught T
- ballast condition and ballast draught corresponding to this condition in the loading manual, or the lesser value of $0,04 L$ and 10 m
- Multi-Port (MP) loading conditions, if allowed by the loading manual, at draught amidships considered in the loading manual.

Unless otherwise specified, these loading conditions are to be associated with the HVM and FVM dynamic load cases.

In addition, harbour conditions covering the loading/ unloading sequences as defined in the loading manual are to be considered.

5 Hull scantlings

5.1 Corrosion addition

5.1.1 Value of corrosion addition for tank top

The corrosion addition for tank top of void/dry spaces is to be taken equal to 0 mm.

5.2 Additional requirements

5.2.1 Minimum net thicknesses

The net thickness of the inner bottom plating in holds is to be not less than the value given in Tab 1.

Table 1 : Minimum net thickness of the inner bottom plating in holds

Plating	Minimum net thickness, in mm	
	Inner bottom in holds	Longitudinal framing
Transverse framing		$2,35 (L^{1/3} k^{1/6}) + 0,0045 b$

6 Construction and testing

6.1 Welding and weld connections

6.1.1 The weld factors for some hull structural connections are specified in Tab 2. These weld factors are to be used in lieu of the corresponding factors specified in Pt B, Ch 13, Sec 3, Tab 1 to calculate T connections fillet weld leg length according to Pt B, Ch 13, Sec 3, [3.2.6]. For the connections in Tab 2, continuous fillet welding is to be adopted.

6.2 Special structural details

6.2.1 The specific requirements in Pt B, Ch 13, Sec 5, [2] for ships with the service notation **ore carrier ESP** are to be complied with.

Table 2 : Weld factor w_F

Hull area	Connection		w_F
	of	to	
Double bottom in way of cargo holds	girders	bottom and inner bottom plating	0,48
		floors (interrupted girders)	
	floors	bottom and inner bottom plating	
		girders (interrupted floors)	
Bulkheads in cargo holds	structures of watertight bulkheads	longitudinal bulkheads	

Part D

Service Notations

CHAPTER 6

COMBINATION CARRIERS

Section 1	General
Section 2	Ship Arrangement
Section 3	Hull and Stability
Section 4	Machinery and Cargo Systems

Section 1 General

1 General

1.1 Application

1.1.1 Ships complying with the requirements of this Chapter are eligible for the assignment of the service notation **combination carrier**, as defined in Pt A, Ch 1, Sec 2, [4.3.4] and Pt A, Ch 1, Sec 2, [4.3.5].

1.1.2 Ships dealt with in this Chapter are to comply with:

- Part A of the Rules,
- NR216 Materials and Welding,
- applicable requirements according to Tab 1.

Table 1 : Applicable requirements

Item		Greater than or equal to 500 GT	Less than 500 GT
Ship arrangement	L ≥ 65 m	<ul style="list-style-type: none"> • Part B • Ch 6, Sec 2 	<ul style="list-style-type: none"> • NR566 • Ch 6, Sec 2
	L < 65 m	<ul style="list-style-type: none"> • NR600 	<ul style="list-style-type: none"> • NR566 • Ch 6, Sec 2
Hull	L ≥ 65 m	<ul style="list-style-type: none"> • Part B • Ch 6, Sec 3 	<ul style="list-style-type: none"> • Part B • Ch 6, Sec 3
	L < 65 m	<ul style="list-style-type: none"> • NR600 	<ul style="list-style-type: none"> • NR600
Stability		<ul style="list-style-type: none"> • Part B • Ch 6, Sec 3 	<ul style="list-style-type: none"> • NR566 • Ch 6, Sec 3
Machinery and cargo systems		<ul style="list-style-type: none"> • Part C • Ch 6, Sec 4 	<ul style="list-style-type: none"> • NR566 • Ch 6, Sec 4
Electrical installations		<ul style="list-style-type: none"> • Part C 	<ul style="list-style-type: none"> • NR566
Automation		<ul style="list-style-type: none"> • Part C 	<ul style="list-style-type: none"> • NR566
Fire protection, detection and extinction		<ul style="list-style-type: none"> • Part C 	<ul style="list-style-type: none"> • NR566
<p>Note 1: NR566: Hull Arrangement, Stability and Systems for Ships less than 500 GT. NR600: Hull Structure and Arrangement for the Classification of Cargo Ships less than 65 m and Non Cargo Ships less than 90 m.</p>			

Section 2 Ship Arrangement

1 General arrangement design

1.1 General

1.1.1 Forecastle

Ships with the service notation **combination carrier/OBO ESP** or **combination carrier/OOC ESP** are to be fitted with an enclosed forecastle on the freeboard deck, with its aft bulkhead fitted in way or aft of the forward bulkhead of the foremost hold, as shown in Fig 1.

However, if this requirement hinders hatch cover operation, the aft bulkhead of the forecastle may be fitted forward of the forward bulkhead of the foremost cargo hold provided the forecastle length is not less than 7% of ship length abaft the forward perpendicular where the ship length and forward perpendicular are defined in the International Convention on Load Lines 1966 and its Protocol 1988.

The forecastle height H_F above the main deck is to be not less than:

- the standard height of a superstructure as specified in Pt B, Ch 1, Sec 3, [2.2.9]
- $H_C + 0,5$ m, where H_C is the height of the forward transverse hatch coaming of the foremost cargo hold, i.e. cargo hold No. 1, whichever is the greater.

All points of the aft edge of the forecastle deck are to be located at a distance l_F :

$$l_F \leq 5\sqrt{H_F - H_C}$$

from the hatch coaming plate in order to apply the reduced loading to the No. 1 forward transverse hatch coaming and No. 1 hatch cover in applying Pt B, Ch 11, Sec 9, [4.1.3], and Pt B, Ch 11, Sec 9, [8.3.9].

A breakwater is not to be fitted on the forecastle deck with the purpose of protecting the hatch coaming or hatch covers. If fitted for other purposes, it is to be located such that its upper edge at centre line is not less than $H_B / \tan 20^\circ$ forward of the aft edge of the forecastle deck, where H_B is the height of the breakwater above the forecastle (see Fig 1).

Figure 1 : Forecastle arrangement

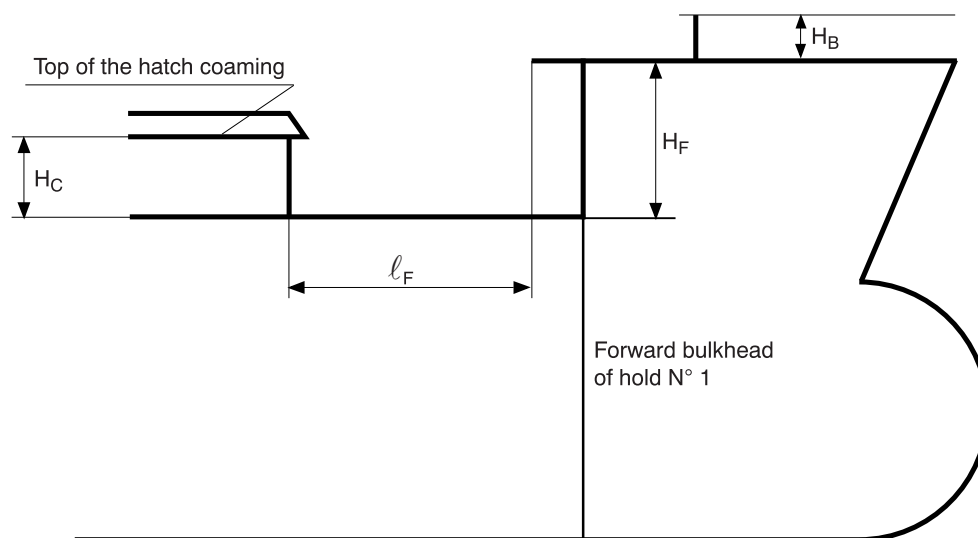

1.1.2 Cofferdams

A cofferdam or similar compartment of width not less than 760 mm is to be provided at the aft end of the oil cargo tank area. Its bulkheads are to extend from keel to deck across the full breadth of the ship.

For the purpose of this requirement, the term "cofferdam" is intended to mean an isolating compartment between two adjacent steel bulkheads or decks. The minimum distance between the two bulkheads or decks is to be sufficient for safe access and inspection.

For continuity reason, in the particular case when a corner-to-corner situation occurs, welding a diagonal plate across the corner may be accepted.

Cofferdams are also to be constructed so as to enable adequate ventilation.

1.1.3 Cargo segregation

Unless expressly provided otherwise, tanks containing oil cargoes or oil cargo residues are to be segregated from accommodation, service and machinery spaces, drinking water and stores for human consumption by means of a cofferdam, or any other similar compartment.

Where accommodation and service compartments are arranged immediately above the compartments containing flammable liquids, the cofferdam may be omitted only where the deck is not provided with access openings and is coated with a layer of material recognised as suitable by the Society. The cofferdam may also be omitted where such compartments are adjacent to a passageway, subject to the following conditions:

- the thicknesses of common boundary plates of adjacent tanks are increased with respect to those obtained from the applicable requirements in Part B and Ch 6, Sec 3, by 2 mm in the case of tanks carrying fresh water or boiler feed water, and by 1 mm in all other cases
- the sum of the throats of the weld fillets at the edges of such plates is not less than the thickness of the plates themselves
- the hydrostatic test is carried out with a head increased by 1 m with respect to that required in Pt B, Ch 13, Sec 6.

Combination carriers of 600 t deadweight and above are not allowed to carry oil in any compartment extending forward of a collision bulkhead located in accordance with Pt B, Ch 2, Sec 1, [3].

1.1.4 Location of fuel tanks in cargo area

On ships carrying liquid cargoes having a flashpoint not exceeding 60°C, fuel tanks located with a common boundary to cargo or slop tanks are not to be situated within, nor extend partly into, the cargo tank block as defined in Ch 7, Sec 1, [1.2.4]. Such tanks may, however, be situated aft and/or forward of the cargo tank block. They may be accepted when located as independent tanks on open deck in the cargo area subject to spill and fire safety considerations.

The arrangement of independent fuel tanks and associated fuel piping systems, including the pumps, may be as for fuel tanks and associated fuel piping systems located in the machinery spaces. For electrical equipment, requirements applicable to hazardous area classification must however be met.

1.1.5 Slop tanks

The slop tanks are to be surrounded by cofferdams except where the boundaries of the slop tanks are part of the hull, main cargo deck, cargo pump room bulkhead or fuel oil bunker tank. These cofferdams are not to be open to a double bottom, pipe tunnel, pump room or other enclosed space, nor they are to be used for cargo or ballast and they are not to be connected to piping systems serving oil cargo or ballast. Means are to be provided for filling the cofferdams with water and for draining them.

Where the boundary of a slop tank is part of the cargo pump room bulkhead, the pump room is not to be open to the double bottom, pipe tunnel or other enclosed space; however, openings provided with gas-tight bolted covers may be permitted.

1.1.6 Deck spills

Means are to be provided to keep deck spills away from the accommodation and service areas. This may be accomplished by providing a permanent continuous coaming of a height of at least 300 mm, extending from side to side.

Where gutter bars are installed on the weather decks of combination carriers in way of cargo manifolds and are extended aft as far as the aft bulkhead of superstructures for the purpose of containing cargo spills on deck during loading and discharge operations, the free surface effects caused by containment of a cargo spill during liquid transfer operations or of boarding seas while underway are to be considered with respect to the vessel's available margin of positive initial stability (GM_0).

Where the gutter bars installed are higher than 300 mm, they are to be treated as bulwarks with freeing ports arranged in accordance with Pt B, Ch 11, Sec 12, [6] and provided with effective closures for use during loading and discharge operations. Attached closures are to be arranged in such a way that jamming is prevented while at sea, enabling the freeing ports to remain effective.

An assessment of the initial stability (GM_0) for compliance with the relevant intact stability requirements taking into account the free surface effect caused by liquids contained by the gutter bars is to be undertaken on:

- tankers having cargo tanks exceeding 60% of the vessel's maximum beam at midships regardless of gutter bar height
- ships without deck camber
- ships where the height of the installed gutter bars exceeds the camber.

1.1.7 Piping

Oil cargo lines below deck are to be placed in special ducts.

1.1.8 Opening in watertight bulkheads and decks

Openings intended to be used for dry cargo handling are not permitted in bulkheads and decks separating oil cargo tanks from other compartments not designed and equipped for the carriage of oil cargoes unless such openings are equipped with alternative means approved by the Society to ensure an equivalent integrity.

1.1.9 Tank cleaning openings

Hatches and tank cleaning openings to slop tanks are only permitted on the open deck and are to be fitted with closing arrangements.

Except where they consist of bolted plates with bolts at watertight spacing, these closing arrangements are to be provided with locking arrangements which are to be under the control of the responsible ship's officer.

1.2 Double bottom tanks or compartments

1.2.1 General

Double bottom tanks adjacent to cargo tanks are not to be used as fuel oil tanks.

1.2.2 Combination carriers of 5000 t deadweight and above

At any cross-section, the depth of each double bottom tank or compartment is to be such that the distance h between the bottom of the cargo tanks and the moulded line of the bottom shell plating measured at right angles to the bottom shell plating, as shown in Fig 2, is not less than $B/15$, in m, or 2,0 m, whichever is the lesser. h is to be not less than 1,0 m.

1.2.3 Combination carriers of less than 5000 t but at least 600 t deadweight

At any cross-section, the depth of each double bottom tank or compartment is to be such that the distance h between the bottom of the cargo tanks and the moulded line of the bottom shell plating measured at right angles to the bottom shell is not less than $B/15$, in m, with a minimum value of 0,76 m.

In the turn of the bilge area and at locations without a clearly defined turn of the bilge, the cargo tank boundary line is to run parallel to the line of the midship flat bottom as shown in Fig 3.

1.3 Navigation position

1.3.1 When it is proven necessary to provide a navigation station above the cargo area, such station is to be for navigation purposes only and is to be separated from the cargo tank deck by an open space of at least 2 m in height.

Figure 2 : Cargo tank boundary lines

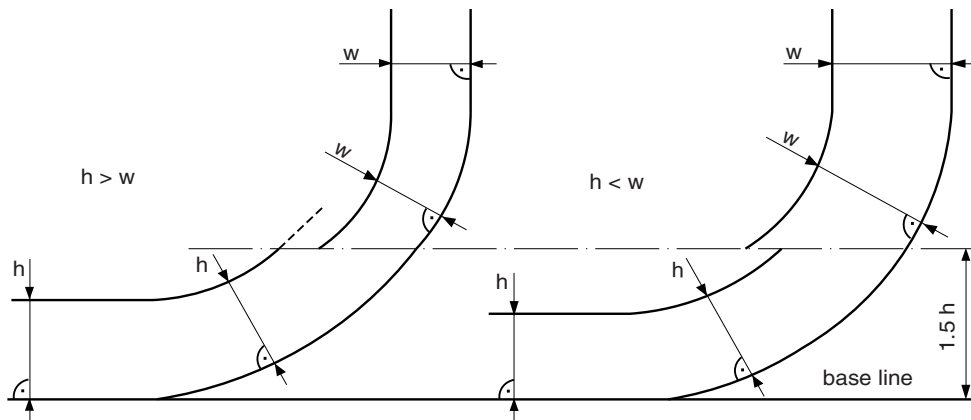
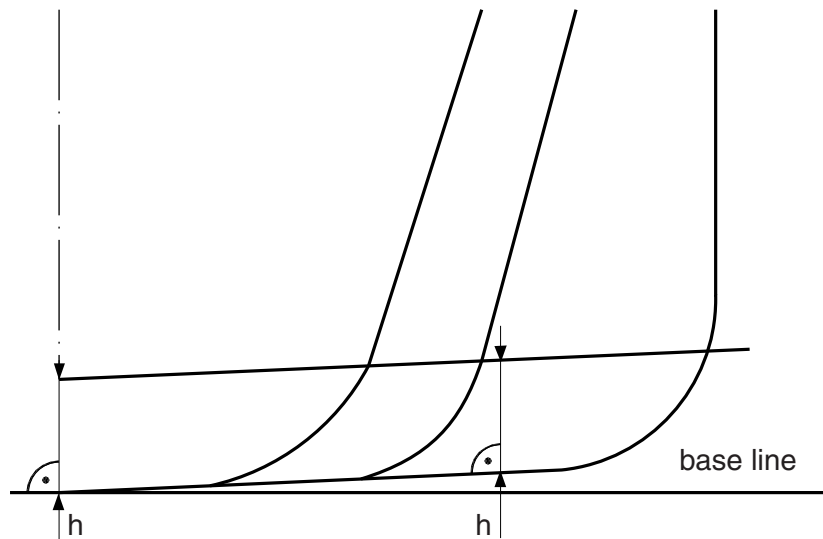

Figure 3 : Cargo tank boundary lines



2 Size and arrangement of cargo tanks and slop tanks

2.1 Cargo tanks

2.1.1 Cargo tanks of combination carriers are to be of such size and arrangements that the hypothetical outflow O_C or O_S calculated in accordance with the provisions of [2.2] anywhere in the length of the ship does not exceed:

- 30000 m³, or
- $400\sqrt[3]{DW}$

where DW is the deadweight, in t,

whichever is the greater, but subject to a maximum of 40000 m³.

2.1.2 The length of each cargo tank is not to exceed 10 metres or one of the values of Tab 1, as applicable, whichever is the greater.

Table 1 : Length of cargo tanks

Longitudinal bulkhead arrangement	Condition (1)	Length of cargo tanks, in m
No bulkhead (combination carrier/OBO ESP)	–	$(0,5 b_i / B + 0,1) L_{LL}$ (2)
Two bulkheads (combination carrier/OOC ESP)	$b_i / B \geq 1/5$	0,2 L_{LL}
	$b_i / B < 1/5$	$(0,5 b_i / B + 0,1) L_{LL}$
(1) b_i is the minimum distance from the ship side to the outer longitudinal bulkhead of the -th tank, measured inboard at right angles to the centreline at the level corresponding to the assigned summer freeboard.		
(2) Not to exceed 0,2 L_{LL} .		

2.1.3 Cargo transfer system

In order not to exceed the volume limits established by [2.1.1] and irrespective of the accepted type of cargo transfer system installed, when such system interconnects two or more cargo tanks, valves or other similar closing devices are to be provided for separating the tanks from each other.

2.1.4 Piping through cargo tanks

Lines of piping which run through oil cargo tanks in a position less than t_c from the ship side or less than v_c from the ship's bottom are to be fitted with valves or similar closing devices at the point at which they open into any cargo tank. These valves are to be kept closed at sea at any time when the tanks contain cargo oil, except that they may be opened only for cargo transfer needed for the purpose of trimming of the ship.

t_c and v_c are, respectively, the transverse and the vertical extent of side damage as defined in Ch 6, Sec 3, [2.3.2].

2.1.5 Suction wells in cargo tanks

Suction wells in cargo tanks may protrude into the double bottom below the boundary line defined by the distance h in [1.2.2] or [1.2.3], as applicable, provided that such wells are as small as practicable and the distance between the well bottom and bottom shell plating is not less than 0,5 h .

2.2 Oil outflow

2.2.1 General

In order to limit the oil pollution from combination carriers due to side and bottom damages, the hypothetical oil outflows O_C and O_S as referred to in [2.1.1] are to be calculated by the formulae of [2.2.2] with respect to compartments breached by damage to all conceivable locations along the length of the ship to the extent as defined in Ch 6, Sec 3, [2.3.2].

In calculating the hypothetical oil outflows, the following is to be considered:

- the volume of an oil cargo tank is to include the volume of the hatchway up to the top of the hatchway coamings, regardless of the construction of the hatch, but may not include the volume of any hatch cover; and
- for the measurement of the volume to moulded lines, no deduction is to be made for the volume of internal structures.

2.2.2 General calculation of oil outflow

The oil outflow for side and bottom damages is calculated by the following formulae:

a) for side damages:

$$O_C = \Sigma W_i + \Sigma K_i C_i$$

b) for bottom damages:

$$O_S = \frac{1}{3}(\Sigma Z_i W_i + \Sigma Z_i C_i)$$

where:

- W_i : Volume of a wing tank in cubic metres assumed to be breached by the damage as specified in Ch 6, Sec 3, [2.3.2]; W_i for a segregated ballast tank may be taken equal to zero
- C_i : Volume of a centre tank in cubic metres assumed to be breached by the damage as specified in Ch 6, Sec 3, [2.3.2]; C_i for a segregated ballast tank may be taken equal to zero
- K_i : Coefficient defined as:
- $1 - b_i / t_c$ for $b_i < t_c$
 - 0 for $b_i \geq t_c$
- Z_i : Coefficient defined as:
- $1 - h_i / v_s$ for $h_i < v_s$
 - 0 for $h_i \geq v_s$
- b_i : Width, in m, of wing tank under consideration measured inboard from the ship side at right angles to the centreline at the level corresponding to the assigned summer freeboard. In a case where the width b_i is not constant along the length of a particular wing tank, the smallest b_i value in the tank is to be used for the purposes of assessing the hypothetical outflows of oil O_c and O_s
- h_i : Minimum depth, in m, of the double bottom under consideration; where no double bottom is fitted, h_i is to be taken equal to zero
- t_c : Transverse extent of side damage as defined in Ch 6, Sec 3, [2.3.2]
- v_s : Vertical extent of bottom damage as defined in Ch 6, Sec 3, [2.3.2].

2.2.3 Bottom damage involving simultaneously four centre tanks

In the case where bottom damage simultaneously involves four centre tanks, the value of O_s may be calculated according to the formula:

$$O_s = \frac{1}{4}(\sum Z_i W_i + \sum Z_i C_i)$$

where Z_i , W_i and C_i are defined in [2.2.2].

2.2.4 Assumptions

For the purpose of calculating O_s , credit is only to be given in respect of double bottom tanks which are either empty or carrying clean water when cargo is carried in the tanks above.

Suction wells may be neglected in the determination of the value h_i provided such wells are not excessive in area and extend below the tank for a minimum distance and in no case more than half the height of the double bottom. If the depth of such a well exceeds half the height of the double bottom, h_i is to be taken equal to the double bottom height minus the well height.

Piping serving such wells if installed within the double bottom is to be fitted with valves or other closing arrangements located at the point of connection to the tank served to prevent oil outflow in the event of damage to the piping.

2.2.5 Reduction of oil outflow

The Society may credit as reducing oil outflow in the event of bottom damage, an installed cargo transfer system having an emergency high suction in each cargo oil tank, capable of transferring from a breached tank or tanks to segregated ballast tanks or to available cargo tankage if it can be ensured that such tanks will have sufficient ullage. Credit for such a system would be governed by ability to transfer in two hours of operation oil equal to one half of the largest of the breached tanks involved and by availability of equivalent receiving capacity in ballast or cargo tanks. The credit is to be confined to permitting calculation of O_s according to the formula in [2.2.3]. The pipes for such suctions are to be installed at least at a height not less than the vertical extent of the bottom damage v_s .

v_s is the vertical extent of bottom damage as defined in Ch 6, Sec 3, [2.3.2].

2.2.6 Alternative methods for calculating oil outflow

As an alternative to the formulae indicated in [2.2.2] or [2.2.3], the probabilistic methodology for calculating oil outflow as described in IMO Resolution MEPC.110(49) may be applied.

2.3 Slop tanks**2.3.1 Combination carriers of 150 gross tonnage and above**

The arrangements of the slop tank or combination of slop tanks are to have a capacity necessary to retain the slop generated by tank washings, oil residues and dirty ballast residues. The total capacity of the slop tank or tanks is to be not less than 3 per cent of the oil carrying capacity of the ships, except that the Society may accept:

- 2% for such combination carriers where the tank washing arrangements are such that once the slop tank or tanks are charged with washing water, this water is sufficient for tank washing and, where applicable, for providing the driving fluid for ejectors, without the introduction of additional water into the system
- 2% where segregated ballast tanks are provided in accordance with Article [4]. This capacity may be further reduced to 1,5% for such combination carriers where the tank washing arrangements are such that once the slop tank or tanks are charged

with washing water, this water is sufficient for tank washing and, where applicable, for providing the driving fluid for ejectors, without the introduction of additional water into the system.

- 1% for combination carriers where oil cargo is only carried in tanks with smooth walls. This capacity may be further reduced to 0,8% where the tank washing arrangements are such that once the slop tank or tanks are charged with washing water, this water is sufficient for tank washing and, where applicable, for providing the driving fluid for ejectors, without the introduction of additional water into the system.

The term "tanks with smooth walls" includes the main oil cargo tanks of combination carriers which may be constructed with vertical framing of a small depth. Vertically corrugated bulkheads are considered smooth walls.

2.3.2 Combination carriers of 70000 t deadweight and above

Combination carriers of 70000 t deadweight and above are to be provided with at least two slop tanks.

3 Size and arrangement of protective ballast tanks or compartments

3.1 General

3.1.1 This requirement applies to combination carriers of 600 t deadweight and above.

3.2 Size and arrangement of ballast tanks or compartments

3.2.1 General

The entire oil cargo tank length is to be protected by ballast tanks or compartments other than oil cargo and fuel oil tanks as indicated in [3.2.2] to [3.2.5] for combination carriers of 5000 t deadweight and above, or [3.2.6] for combination carriers less than 5000 t deadweight.

3.2.2 Wing tanks or compartments

Wing tanks or compartments are to extend either for the full depth of the ship side or from the top of the double bottom to the uppermost deck, disregarding a rounded gunwale where fitted. They are to be arranged such that the oil cargo tanks are located inboard of the moulded line of the side shell plating, nowhere less than the distance w which, as shown in Fig 2, is measured at any cross-section at right angles to the side shell, as specified below:

- $w = 0,5 + DW / 20000$, or
- $w = 2,0$ m

whichever is the lesser.

The value of w is to be at least 1,0 m.

3.2.3 Double bottom tanks or compartments

The requirements of [1.2.1] and [1.2.2] apply.

3.2.4 Aggregate capacity of ballast tanks

On combination carriers of 20000 t deadweight and above, the aggregate capacity of wing tanks, double bottom tanks, fore peak tanks and after peak tanks is to be not less than the capacity of segregated ballast tanks necessary to meet the requirements of [4]. Wing tanks or compartments and double bottom tanks used to meet the requirements of [4] are to be located as uniformly as practicable along the oil cargo tank length. Additional segregated ballast capacity provided for reducing longitudinal hull girder bending stress, trim, etc., may be located anywhere within the ship.

In calculating the aggregate capacity, the following is to be taken into account:

- the capacity of engine-room ballast tanks is to be excluded from the aggregate capacity of ballast tanks
- the capacity of ballast tanks located inboard of double hull is to be excluded from the aggregate capacity of ballast tanks (see Fig 4)
- spaces such as void spaces located in the double hull within the cargo tank length should be included in the aggregate capacity of ballast tanks

Any ballast carried in localised inboard extensions, indentation or recesses of the double hull, such as bulkhead stools, should be considered as excess ballast above the minimum requirement for segregated ballast capacity according to [4].

3.2.5 Alternative methods of design and construction

Other methods of design and construction of combination carriers may also be accepted as alternatives to the requirements prescribed in [3.2.2] to [3.2.4], provided that such methods ensure at least the same level of protection against oil pollution in the event of collision or stranding. Such methods are to be acceptable to the Society.

Note 1: The Society considers the method described in IMO Resolution MEPC.110(49) as being acceptable.

3.2.6 Combination carriers of less than 5000 t deadweight

Combination carriers of less than 5000 t deadweight are to comply with [1.2.3].

Figure 4 : Segregated ballast tanks located inboard of double hull

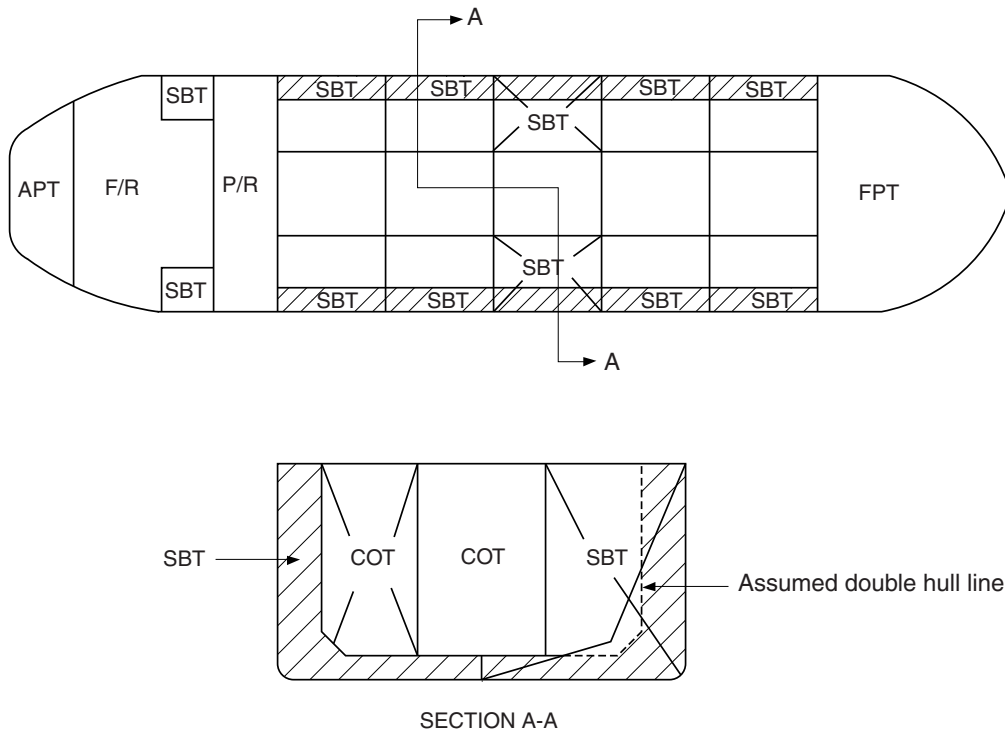

4 Size and arrangement of segregated ballast tanks (SBT)

4.1 General

4.1.1 Every combination carrier of 20000 t deadweight and above is to be provided with segregated ballast tanks and to comply with [4.2].

4.2 Capacity of SBT

4.2.1 Combination carriers equal to or greater than 150 m in length

The capacity of the segregated ballast tanks is to be so determined that the ship may operate safely on ballast voyages without recourse to the use of oil cargo tanks for water ballast. In all cases, however, the capacity of segregated ballast tanks is to be at least such that, in any ballast condition at any part of the voyage, including the conditions consisting of lightweight plus segregated ballast only, the ship's draughts and trim can meet each of the following requirements:

- the moulded draught amidships, d_m in metres (without taking into account any ship's deformation), is to be not less than $2,0 + 0,02 L_{LL}$
- the draughts at the forward and after perpendicular are to correspond to those determined by the draught amidships d_m as specified above, in association with the trim by the stern of not greater than $0,015 L_{LL}$
- in any case the draught at the after perpendicular is to be not less than that which is necessary to obtain full immersion of the propeller(s)
- in no case is ballast water to be carried in oil cargo tanks, except:
 - on those rare voyages when weather conditions are so severe that, in the opinion of the Master, it is necessary to carry additional ballast water in oil cargo tanks for the safety of the ship
 - in exceptional cases where the particular character of the operation of a combination carrier renders it necessary to carry ballast water in excess of the quantity required to comply with the requirements above, provided that such operation of the combination carrier falls under the category of exceptional cases.

4.2.2 Combination carriers less than 150 m in length

The capacity of the segregated ballast tanks is to be considered by the Society on a case-by-case basis.

5 Access arrangement

5.1 Access to double bottom and pipe tunnel

5.1.1 Means of access

Adequate means of access to the double bottom and the pipe tunnel are to be provided.

5.1.2 Manholes in the inner bottom, floors and girders

Manholes are not to be cut in the inner bottom in way of oil cargo holds; access to the double bottom is, in general, to be provided by trunks leading to the upper deck.

The location and size of manholes in longitudinal girders and floors are determined to facilitate the access to double bottom structures and their ventilation. However, they are to be avoided in the areas where high shear stresses may occur.

5.1.3 Access to pipe tunnels under oil cargo tanks

The pipe tunnel in the double bottom under oil cargo tanks is to comply with the following requirements:

- it is not to communicate with the engine room
- provision is to be made for at least two exits to the open deck arranged at a maximum distance from each other. One of these exits fitted with a watertight closure may lead to the cargo pump room.

5.1.4 Doors between pipe tunnel and main pump room

Where there is a permanent access from a pipe tunnel to the main pump room, a watertight door is to be fitted complying with the requirements in Pt B, Ch 2, Sec 1, [6.3.1]. In addition the following is to be complied with:

- in addition to bridge operation, the watertight door is to be capable of being manually closed from outside the main pump room entrance
- the watertight door is to be kept closed during normal operations of the ship except when access to the pipe tunnel is required. A notice is to be affixed to the door to this effect.

5.2 Access arrangement to and within spaces in, and forward of, the cargo area

5.2.1 Means of access

Ships with the service notation **combination carrier/OBO ESP** or **combination carrier/OOC ESP** of 20,000 gross tonnage and over, are to comply with provisions of [5.5] and with the International Convention for the Safety of Life at Sea, 1974, as amended, Chapter II-1, Part A-1, Regulation 3-6, as amended, Chapter II-1, Part A-1, Regulation 3-6, for details and arrangements of openings and attachments to the hull structure.

Ships with the service notation **combination carrier/OBO ESP** or **combination carrier/OOC ESP** of less than 20,000 gross tonnage, are to comply with [5.3], [5.4] and [5.5].

5.3 Access to dry cargo holds

5.3.1 Means of access

As far as practicable, permanent or movable means of access stored on board are to be provided to ensure proper survey and maintenance of dry cargo holds.

5.3.2 Hatches of large cargo holds

When the access to the dry cargo hold is arranged through the cargo hatch, the top of the ladder, as required in [5.3.3], is to be placed as close as possible to the hatch coaming.

Accesses and ladders are to be so arranged that personnel equipped with self-contained breathing apparatus may readily enter and leave the dry cargo hold.

Access hatch coamings having a height greater than 900 mm are also to have steps on the outside in conjunction with dry cargo hold ladders.

5.3.3 Ladders within large cargo holds

Each dry cargo hold is to be provided with at least two ladders as far apart as practicable longitudinally. If possible these ladders are to be arranged diagonally, e.g. one ladder near the forward bulkhead on the port side, the other one near the aft bulkhead on the starboard side, from the ship's centreline.

Ladders are to be so designed and arranged that the risk of damage from the cargo handling gear is minimised.

Vertical ladders may be permitted provided they are arranged above each other in line with other ladders to which they form access and resting positions are provided at not more than 9 metres apart.

Tunnels passing through dry cargo holds are to be equipped with ladders or steps at each end of the hold so that personnel may get across such tunnels.

Where it may be necessary for work to be carried out within a dry cargo hold preparatory to loading, consideration is to be given to suitable arrangements for the safe handling of portable staging or movable platforms.

5.4 Access to compartments in the oil cargo area

5.4.1 General

Access to cofferdams, ballast tanks, dry cargo holds, oil cargo tanks and other compartments in the oil cargo area is to be direct from the open deck and such as to ensure their complete inspection.

5.4.2 Access through horizontal openings

For access through horizontal openings the dimensions are to be sufficient to allow a person wearing a self-contained, air-breathing apparatus and protective equipment to ascend or descend any ladder without obstruction and also to provide a clear opening to facilitate the hoisting of an injured person from the bottom of the compartment. The minimum clear opening is to be not less than 600 mm by 600 mm.

5.4.3 Access through vertical openings

For access through vertical openings the minimum clear opening is to be not less than 600 mm by 800 mm at a height of not more than 600 mm from the bottom shell plating unless gratings or other footholds are provided.

5.5 Access to the bow

5.5.1 *Combination carriers are to be provided with the means to enable the crew to gain safe access to the bow even in severe weather conditions. Such means are to be accepted by the Society.*

Note 1: The Society considers means in compliance with the Guidelines adopted by the Maritime Safety Committee of IMO with Resolution MSC.62(67) on 5/12/1996 as being acceptable.

Section 3 Hull and Stability

1 General

1.1 Loading manual and loading instrument

1.1.1 The specific requirements in Pt B, Ch 1, Sec 5 for ships with either of the service notations **combination carrier /OBO ESP** or **combination carrier /OOC ESP** and equal to or greater than 150 m in length are to be complied with.

2 Stability

2.1 Intact stability

2.1.1 General

The stability of the ship for the loading conditions in Pt B, Ch 3, App 2, [1.2.5] is to be in compliance with the requirements in Pt B, Ch 3, Sec 2. Where the ship is intended also for the carriage of grain, the requirements in Ch 4, Sec 3, [1.2.2] and Ch 4, Sec 3, [1.2.3] are to be complied with.

In addition, for the carriage of liquids, the requirements in [2.1.3] are to be complied with.

2.1.2 Liquid transfer operations

Ships with certain internal subdivision may be subjected to lolling during liquid transfer operations such as loading, unloading or ballasting. In order to reduce the effect of lolling, the design of combination carriers of 5000 t deadweight and above is to be such that the following criteria are complied with:

- a) *The intact stability criteria reported in b) are to be complied with for the worst possible condition of loading and ballasting as defined in c), consistent with good operational practice, including the intermediate stages of liquid transfer operations. Under all conditions the ballast tanks are to be assumed slack.*
- b) *The initial metacentric height GMo , in m, corrected for free surface measured at 0° heel, is to be not less than 0,15. For the purpose of calculating GMo , liquid surface corrections are to be based on the appropriate upright free surface inertia moment.*
- c) *The vessel is to be loaded with:*
 - *all cargo tanks filled to a level corresponding to the maximum combined total of vertical moment of volume plus free surface inertia moment at 0° heel, for each individual tank*
 - *cargo density corresponding to the available cargo deadweight at the displacement at which transverse KM reaches a minimum value*
 - *full departure consumable*
 - *1% of the total water ballast capacity. The maximum free surface moment is to be assumed in all ballast tanks.*

2.1.3 Alternative requirements for liquid transfer operation

As an alternative to the requirements in [2.1.2], simple supplementary operational procedures are to be followed when the ship is carrying oil cargoes or during liquid transfer operations.

Simple supplementary operational procedures for liquid transfer operations means written procedures made available to the Master which:

- *are approved by the Society,*
- *indicate those cargo and ballast tanks which may, under any specific condition of liquid transfer and possible range of cargo densities, be slack and still allow the stability criteria to be met. The slack tanks may vary during the liquid transfer operations and be of any combination provided they satisfy the criteria,*
- *are to be readily understandable to the officer-in-charge of liquid transfer operations,*
- *provide for planned sequences of cargo/ballast transfer operations,*
- *allow comparisons of attained and required stability using stability performance criteria in graphical or tabular form,*
- *require no extensive mathematical calculations by the officer-in-charge,*
- *provide for corrective actions to be taken by the officer-in-charge in the event of departure from the recommended values and in case of emergency situations, and*
- *are prominently displayed in the approved trim and stability booklet and at the cargo/ballast transfer control station and in any computer software by which stability calculations are performed.*

2.2 Damage stability - dry cargoes or ballast loading conditions - for ships where additional class notation SDS is requested

2.2.1 General

Combination carriers equal to or greater than 80 m in length are subjected to the probabilistic approach reported in Pt B, Ch 3, Sec 3, [2.1.3] and are to comply with the requirements in Pt B, Ch 3, App 3, for the loading conditions which entail the carriage of dry cargoes or ballast, unless they comply with the requirements in [2.2.2] or [2.3].

2.2.2 Freeboard reduction

Combination carriers greater than 100 m in length which have been assigned reduced freeboard as permitted by Regulation 27 of the International Convention on Load Lines, 1966, as referenced in Pt B, Ch 3, Sec 3, [2.1.2] are to comply with the requirement specified in Pt B, Ch 3, App 4. Therefore, compliance with the requirements in Ch 5, Sec 3, [2.2.1] is not required.

2.3 Damage stability - oil cargoes - for ships where additional class notation SDS is requested

2.3.1 General

In the loading conditions which entail the carriage of oil cargoes, combination carriers are to comply with the subdivision and damage stability criteria as specified in [2.3.8], after the assumed side or bottom damage as specified in [2.3.2], for the standard of damage described in [2.3.3], and for any operating draught reflecting actual partial or full load conditions consistent with trim and strength of the ship as well as specific gravities of the cargo.

The actual partial or full load conditions to be considered are those specified in Pt B, Ch 3, App 2, [1.2.6], but ballast conditions where the ship is not carrying oil in cargo tanks, excluding any oil residues, are not to be considered.

2.3.2 Damage dimensions

The assumed extent of damage is to be as defined in Tab 1.

The transverse extent of damage is measured inboard the ship side at right angles to the centreline at the level of the summer load line.

The vertical extent of damage is measured from the moulded line of the bottom shell plating at centreline.

For the purpose of determining the extent of assumed damage, suction wells may be neglected, provided such wells are not excessive in areas and extend below the tank for a minimum distance and in no case more than half the height of the double bottom.

If any damage of a lesser extent than the maximum extent of damage specified in Tab 1 would result in a more severe condition, such damage is to be considered.

Table 1 : Extent of damage

Damage		Longitudinal extent	Transverse extent	Vertical extent
Side		<ul style="list-style-type: none"> $l_c = 1/3 L_{LL}^{2/3}$ or 14,5 m whichever is the lesser	$t_c = B/5$ 11,5 m whichever is the lesser	$v_c =$ without limit
Bottom	for 0,3 L_{LL} from the forward perpendicular	<ul style="list-style-type: none"> $l_s = 1/3 L_{LL}^{2/3}$ 14,5 m whichever is the lesser	<ul style="list-style-type: none"> $t_s = B/6$ 10 m whichever is the lesser	<ul style="list-style-type: none"> $v_s = B/15$ 6 m whichever is the lesser
	any other part	<ul style="list-style-type: none"> $l_s = 1/3 L_{LL}^{2/3}$ 5 m whichever is the lesser	<ul style="list-style-type: none"> $t_s = B/6$ 5 m whichever is the lesser	<ul style="list-style-type: none"> $v_s = B/15$ 6 m whichever is the lesser

2.3.3 Standard of damage

The damage in [2.3.2] is to be applied to all conceivable locations along the length of the ship, according to Tab 2.

Table 2 : Standard of damage

Ship's length, in m	Damage anywhere in ship's length	Damage between transverse bulkheads	Machinery space flooded alone
$L_{LL} \leq 100$	No	Yes (1) (2)	No
$100 < L_{LL} \leq 150$	No	Yes (1)	No
$150 < L_{LL} \leq 225$	Yes	No	Yes
$L_{LL} > 225$	Yes	No	No

(1) Machinery space not flooded.
 (2) Exemptions from the requirements of [2.3.8] may be accepted by the Society on a case-by-case basis.

2.3.4 Calculation method

The metacentric heights (GM), the stability levers (GZ) and the centre of gravity positions (KG) for judging the final survival conditions are to be calculated by the constant displacement method (lost buoyancy).

2.3.5 Flooding assumptions

The requirements of [2.3.8] are to be confirmed by calculations which take into consideration the design characteristics of the ship, the arrangements, configuration and contents of the damaged compartments and the distribution, specific gravities and free surface effect of liquids.

Where the damage involving transverse bulkheads is envisaged as specified in [2.3.3], transverse watertight bulkheads are to be spaced at least at a distance equal to the longitudinal extent of assumed damage specified in [2.3.2] in order to be considered effective. Where transverse bulkheads are spaced at a lesser distance, one or more of these bulkheads within such extent of damage is to be assumed as non-existent for the purpose of determining flooded compartments.

Where the damage between adjacent transverse watertight bulkheads is envisaged as specified in [2.3.3], no main transverse bulkhead bounding side tanks or double bottom tanks is to be assumed damaged, unless:

- the spacing of the adjacent bulkheads is less than the longitudinal extent of assumed damage specified in [2.3.2] or,
- there is a step or a recess in a transverse bulkhead of more than 3,05 metres in length, located within the extent of penetration of assumed damage. The step formed by the after peak bulkhead and after peak tank top is not to be regarded as a step.

2.3.6 Progressive flooding

If pipes, ducts or tunnels are situated within the assumed extent of damage penetration as defined in [2.3.2], arrangements are to be made so that progressive flooding cannot thereby extend to compartments other than those assumed to be floodable in the calculation for each case of damage.

2.3.7 Permeabilities

The specific gravity of cargoes carried, as well as any outflow of liquid from damaged compartments, are to be taken into account for any empty or partially filled tank.

The permeability of compartments assumed to be damaged is to be as indicated in Tab 3.

Table 3 : Permeability

Compartments	Permeability
Appropriated for stores	0,60
Occupied by accommodation	0,95
Occupied by machinery	0,85
Void compartments	0,95
Intended for consumable liquids	0 to 0,95 (1)
Intended for other liquids	0 to 0,95 (1)

(1) The permeability of partially filled compartments is to be consistent with the amount of liquid carried in the compartment.

2.3.8 Survival requirements

Combination carriers, in the damage case of [2.3], are to be regarded as complying with the damage stability criteria if the requirements of [2.3.9] and [2.3.10] are met.

2.3.9 Final stage of flooding

- a) The final waterline, taking into account sinkage, heel and trim, is to be below the lower edge of any opening through which progressive flooding may take place. The progressive flooding is to be considered in accordance with Pt B, Ch 3, Sec 3, [3.3].
- b) The angle of heel due to unsymmetrical flooding may not exceed 25°, except that this angle may be increased up to 30° if no deck edge immersion occurs.
- c) The stability is to be investigated and may be regarded as sufficient if the righting lever curve has at least a range of 20° beyond the position of equilibrium in association with a maximum residual righting lever, in m, of at least 0,1 within the 20° range; the area, in m-rad, under the curve within this range is to be not less than 0,0175.

2.3.10 Intermediate stage of flooding

The Society is to be satisfied that the stability is sufficient during the intermediate stages of flooding. To this end the Society applies the same criteria relevant to the final stage of flooding also during the intermediate stages of flooding.

2.3.11 Bottom raking damage

This requirement applies to combination carriers of 20000 t deadweight and above.

The damage assumptions relative to the bottom damage prescribed in [2.3.2] are to be supplemented by the assumed bottom raking damage of Tab 4.

The requirements of [2.3.8] are to be complied with for the assumed bottom raking damage.

Table 4 : Bottom damage extent

Deadweight	Longitudinal extent	Transverse extent	Vertical extent
< 75000 t	0,4 L _{LL} (1)	B/3	(2)
≥ 75000 t	0,6 L _{LL} (1)	B/3	(2)
(1) Measured from the forward perpendicular.			
(2) Breach of the outer hull.			

2.3.12 Equalisation arrangements

Equalisation arrangements requiring mechanical aids such as valves or cross levelling pipes, if fitted, may not be considered for the purpose of reducing an angle of heel or attaining the minimum range of residual stability to meet the requirements of [2.3.9] and sufficient residual stability is to be maintained during all stages where equalisation is used. Compartments which are linked by ducts of a large cross-sectional area may be considered to be common.

2.3.13 Information to the Master

The Master of every combination carrier is to be supplied in an approved form with:

- information relative to loading and distribution of cargo necessary to ensure compliance with the requirements relative to stability, and
- data on the ability of the ship to comply with damage stability criteria as determined in [2.3.8] including the effect of relaxation that may have been allowed as specified in Tab 2.

3 Structure design principles of ships with the service notation combination carrier / OBO ESP

3.1 Double bottom structure

3.1.1 Longitudinally framed double bottom

In ships greater than 120 m in length, the double bottom and the sloped bulkheads of hopper tanks are to be longitudinally framed.

The girder spacing is to be not greater than 4 times the spacing of bottom or inner bottom ordinary stiffeners and the floor spacing is to be not greater than 3 frame spaces.

Greater spacing may be accepted by the Society, on a case-by-case basis, depending on the results of the analysis carried out according to Pt B, Ch 7, Sec 6 for the primary supporting members in the cargo holds.

3.1.2 Transversely framed double bottom

The double bottom and the sloped bulkheads of hopper tanks may be transversely framed in ships less than or equal to 120 m in length, when this is deemed acceptable by the Society on a case-by-case basis. In this case, however, the floor spacing is to be not greater than 2 frame spaces.

3.1.3 Floors in way of transverse bulkheads

The thickness and material properties of the supporting floors and pipe tunnel beams are to be not less than those required for the bulkhead plating or, when a stool is fitted, of the stool side plating.

3.2 Double side structure

3.2.1 General

The side within the hopper and topside tanks is, in general, to be longitudinally framed. It may be transversely framed when this is accepted for the double bottom and the deck according to [3.1.2] and [3.3.1], respectively.

3.2.2 Side primary supporting members

The spacing of transverse side primary supporting members is to be not greater than 3 frame spaces.

Greater spacing may be accepted by the Society, on a case-by-case basis, depending on the results of the analysis carried out according to Pt B, Ch 7, Sec 6 for the primary supporting members in the cargo holds.

In any case, transverse side primary supporting members are to be fitted in line with transverse primary supporting members in hopper and topside tanks.

3.3 Deck structure

3.3.1 Deck outside the line of hatches and topside tank sloping plates

In ships greater than 120 m in length, the deck outside the line of hatches and the topside tank sloping plates are to be longitudinally framed.

The spacing of transverse primary supporting members in topside tanks is to be not greater than 6 frame spaces.

Greater spacing may be accepted by the Society, on a case-by-case basis, depending on the results of the analysis carried out according to Pt B, Ch 7, Sec 6 for the primary supporting members in the cargo holds.

3.3.2 Deck between hatches

The cross decks between hatches are generally to be transversely framed.

3.3.3 Connection of hatch end beams with deck structures

The connection of hatch end beams with deck structures is to be properly ensured by fitting inside the topside tanks additional web frames or brackets.

3.3.4 Topside tank structure

Topside tank structures are to extend as far as possible within the machinery space and are to be adequately tapered.

4 Structure design principles of ships with the service notation combination carrier / OOC ESP

4.1 Double bottom structure

4.1.1 The double bottom is to be longitudinally framed.

The girder spacing is to be not greater than 4 times the spacing of bottom or inner bottom ordinary stiffeners and the floor spacing is to be not greater than 3 frame spaces.

Solid floors are to be fitted in line with the transverse primary supporting members in wing tanks and intermediate floors are to be added at mid-span between primary supporting members.

4.1.2 Other arrangements may be accepted by the Society, on a case-by-case basis, depending on the results of the analysis carried out according to Pt B, Ch 7, Sec 6 for the primary supporting members in the cargo holds.

4.1.3 Scarfing of the double bottom structure into the wing tanks is to be properly ensured. The inner bottom plating is generally to be prolonged within the wing tanks by adequately sized horizontal brackets in way of floors.

4.2 Side structure

4.2.1 In ships greater than 120 m in length, the side shell is to be longitudinally framed.

In general, the spacing of vertical primary supporting members is to be not greater than 6 times the frame spacing.

4.2.2 Other arrangements may be accepted by the Society, on a case-by-case basis, depending on the results of the analysis carried out according to Pt B, Ch 7, Sec 6 for the primary supporting members in the cargo hold.

4.3 Deck structure

4.3.1 The deck outside the line of hatches is to be longitudinally framed.

4.3.2 The cross decks between hatches are generally to be transversely framed.

4.3.3 The connection of hatch end beams with deck structures is to be properly ensured by fitting inside the wing tanks additional web frames or brackets.

4.4 Longitudinal bulkhead structure

4.4.1 Longitudinal bulkheads are to be plane, but they may be knuckled in the upper part and in the lower part to form a hopper. In these cases, the design of the knuckles and the adjacent structures is to be considered by the Society on a case-by-case basis.

4.4.2 In ships greater than 120 m in length, longitudinal bulkheads are to be longitudinally framed.

4.4.3 Other arrangements may be accepted by the Society, on a case-by-case basis, depending on the results of the analysis carried out according to Pt B, Ch 7, Sec 6 for the primary supporting members in the cargo hold.

4.5 Transverse bulkhead structure

4.5.1 Where the structural arrangement of transverse bulkheads in wing tanks is different from that in centre holds, arrangements are to be made to ensure continuity of the transverse strength through the longitudinal bulkheads.

5 Design loads

5.1 Loading conditions for longitudinal strength assessment

5.1.1 In addition to the requirements in Pt B, Ch 5, Sec 4, [2.1.1], still water loads are to be calculated for the following loading conditions, subdivided into departure and arrival conditions as appropriate:

- alternate light and heavy cargo (dry or oil) loading conditions at maximum draught, where applicable
- homogeneous light and heavy cargo (dry or oil) loading conditions at maximum draught
- ballast conditions. For ships having ballast holds adjacent to topside wing, hopper and double bottom tanks, it may be acceptable in terms of strength that the ballast holds are filled when the topside wing, hopper and double bottom tanks are empty. Partial filling of the peak tanks is not acceptable in the design ballast conditions, unless effective means are provided to prevent accidental overfilling
- short voyage conditions where the ship is to be loaded to maximum draught but with a limited amount of bunkers
- Multi-port (MP) loading/unloading conditions, if allowed by the loading manual (see Pt B, Ch 1, Sec 5, [2])
- deck cargo conditions, where applicable
- typical loading sequences where the ship is loaded from commencement of cargo loading to reaching full deadweight capacity, for homogeneous conditions, relevant part load conditions and alternate conditions where applicable.

Typical unloading sequences for these conditions are also to be included. The typical loading/unloading sequences are also to be developed so as not to exceed applicable strength limitations. The typical loading sequences are also to be developed paying due attention to the loading rate and deballasting capability

- typical sequences for change of ballast at sea, where applicable.

5.2 Load combinations for direct strength analysis

5.2.1 Applicable general load combinations

The following load combinations are to be considered as defined in:

- Ch 5, Sec 3, [4.2] and Ch 7, Sec 3, [4.3] for ships assigned with the service notation **combination carrier /OOC ESP**
- Ch 4, Sec 3, [3.3] and Ch 7, Sec 3, [4.3] for ships assigned with the service notation **combination carrier /OBO ESP**.

5.3 Local loads

5.3.1 Bottom impact pressure

For combination carriers of 20000 t deadweight and above, the draught T_F , to be considered in the calculation of the bottom impact pressure according to Pt B, Ch 5, Sec 5, [4.2.1], is that calculated by using the segregated ballast tanks only.

5.3.2 Oil cargo mass density

In the absence of more precise values, an oil cargo mass density of 0,9 t/m³ is to be considered for calculating the internal pressures and forces in cargo tanks according to Pt B, Ch 5, Sec 6 or NR600, as applicable.

6 Hull scantlings

6.1 Strength check with respect to stresses due to the temperature gradient

6.1.1 General

Direct calculations of stresses induced in the hull structures by the temperature gradient are to be performed:

- for ships intended to carry cargoes at temperatures exceeding 90°C
- and when part of the hull structures temperature exceeds 90°C

In these calculations, the water temperature is to be assumed equal to 0°C.

The calculations are to be submitted to the Society for review.

6.1.2 Material

For steels used at a temperature θ between 90°C and 300°C, and unless other information is specified, their minimum yield stress R_{eH} and Young's modulus E are to be taken as specified in Pt B, Ch 4, Sec 1, [2.1.1].

The material factor is to be adjusted accordingly.

6.1.3 Thermal stress for integral tanks

The stresses induced in the hull structures by the temperature gradient are to comply with the checking criteria in Pt B, Ch 8, App 1, [5.2.3].

6.1.4 Thermal stress for independent tanks

Where a thermal elongation is made possible due to the design of the tank supports, the thermal stress may be neglected provided the cargo temperature distribution is rather uniform.

In addition, precautions are to be taken, upon loading of any hot cargo, by pre-heating the tanks in order to minimize the temperature gradients within the cargo hold.

7 Other structures

7.1 Machinery space

7.1.1 Extension of hull structures within the machinery space

Longitudinal bulkheads or inner side, as applicable, carried through cofferdams are to continue within the machinery space and are to be used preferably as longitudinal bulkheads for liquid cargo tanks. In any case, such extension is to be compatible with the shape of the structures of the double bottom, deck and platforms of the machinery space.

Where topside tanks are fitted, their structures are to extend as far as possible within the machinery space and to be adequately tapered.

7.2 Opening arrangement

7.2.1 Cargo shore connection

Entrances, air inlets and openings to accommodation, service and machinery spaces and control stations may not face the cargo shore connection location of bow or stern loading and unloading arrangements. They are to be located on the outboard side of the superstructure or deckhouse at a distance of at least 4% of the ship's length but not less than 3 m from the end of the deckhouse facing the cargo shore connection location of the bow or stern loading and unloading arrangements. This distance, however, need not exceed 5 m. Sidescuttles facing the shore connection location and on the sides of the superstructure or deckhouse within the distance mentioned above are to be of the fixed (non-opening) type. All doors, ports and other openings on the corresponding superstructure or deckhouse side are to be fitted so that they can be kept closed during the use of the bow or stern loading and unloading arrangements. The Society may permit departures from these requirements in the case of small ships when, at its discretion, compliance with them is not possible.

Air pipes and other openings to enclosed compartments not listed above are to be shielded from spray which may come from a leaking hose or connection.

7.2.2 Deck foam system room

An access to a deck foam system room (including the foam tank and the control station) may be permitted within the limits mentioned in Pt C, Ch 4, Sec 6, [3.3.1], provided that the door is located flush with the bulkhead.

7.2.3 Tanks covers

Covers fitted on all cargo tank openings are to be of sturdy construction, and to ensure tightness for hydrocarbon and water.

Aluminium is not permitted for the construction of tank covers. The use of reinforced fibreglass covers is to be specially examined by the Society.

8 Hull outfitting

8.1 Equipment

8.1.1 Emergency towing arrangement

The specific requirements in Pt B, Ch 12, Sec 4, [3] for ships with either of the service notations **combination carrier /OBO ESP** or **combination carrier /OOC ESP** and of 20000 t deadweight and above are to be complied with.

9 Protection of hull metallic structures

9.1 Protection by aluminium coatings

9.1.1 The use of aluminium coatings containing greater than 10% aluminium by weight in the dry film is prohibited in the cargo tanks, cargo tank deck area, pump rooms, cofferdams or any other area where cargo vapour may accumulate.

10 Cathodic protection of tanks

10.1 General

10.1.1 Internal structures in spaces intended to carry liquids may be provided with cathodic protection.

Cathodic protection may be fitted in addition to the required corrosion protective coating, if any.

10.1.2 Details concerning the type of anodes used and their location and attachment to the structure are to be submitted to the Society for approval.

10.2 Anodes

10.2.1 Magnesium or magnesium alloy anodes are not permitted in oil cargo tanks and tanks adjacent to cargo tanks.

10.2.2 Aluminium anodes are only permitted in cargo tanks and tanks adjacent to cargo tanks in locations where the potential energy does not exceed 28 kg m. The height of the anode is to be measured from the bottom of the tank to the centre of the anode, and its weight is to be taken as the weight of the anode as fitted, including the fitting devices and inserts.

However, where aluminium anodes are located on horizontal surfaces such as bulkhead girders and stringers not less than 1 m wide and fitted with an upstanding flange or face flat projecting not less than 75 mm above the horizontal surface, the height of the anode may be measured from this surface.

Aluminium anodes are not to be located under tank hatches or washing holes, unless protected by the adjacent structure.

10.2.3 There is no restriction on the positioning of zinc anodes.

10.2.4 Anodes are to have steel cores and are to be declared by the Manufacturer as being sufficiently rigid to avoid resonance in the anode support and designed so that they retain the anode even when it is wasted.

10.2.5 The steel inserts are to be attached to the structure by means of a continuous weld. Alternatively, they may be attached to separate supports by bolting, provided a minimum of two bolts with lock nuts are used. However, other mechanical means of clamping may be accepted.

10.2.6 The supports at each end of an anode may not be attached to separate items which are likely to move independently.

10.2.7 Where anode inserts or supports are welded to the structure, they are to be arranged by the Shipyard so that the welds are clear of stress peaks.

10.2.8 As a general rule, the requirements Ch 7, Sec 3, [12.2.3] to Ch 7, Sec 3, [12.2.7] apply also to spaces or compartments adjacent to cargo or slop tanks.

10.3 Impressed current systems

10.3.1 Impressed current cathodic protections are not accepted in cargo or slop tanks, unless specially authorized by the Society.

11 Construction and testing

11.1 Welding and weld connections

11.1.1 The weld factors for some hull structural connections are specified in Tab 5. These weld factors are to be used, in lieu of the corresponding factors specified in Pt B, Ch 13, Sec 3, Tab 1, to calculate the leg length of fillet weld T connections according to Pt B, Ch 13, Sec 3, [3.2.6]. For the connections of Tab 5, continuous fillet welding is to be adopted.

Table 5 : Weld factor w_f

Hull area	Connection		Weld factor w_f
	of	to	
Double bottom in way of cargo holds and tanks	girders	bottom and inner bottom plating	0,48
		floors (interrupted girders)	
	floors	bottom and inner bottom plating	
		girders (interrupted floors)	
Bulkheads in oil cargo tanks	ordinary stiffeners	bulkhead plating	0,48

11.2 Special structural details

11.2.1 The specific requirements in Pt B, Ch 13, Sec 5, [2.7] for ships with either of the service notations **combination carrier / OBO ESP** or **combination carrier / OOC ESP** are to be complied with.

Section 4 Machinery and Cargo Systems

1 General

1.1 Application

1.1.1 Ships having the service notation **combination carrier** are to comply with the requirements of Ch 7, Sec 4 applicable to oil tankers or oil tankers flashpoint > 60°C, as appropriate.

In addition, they are to comply with the provisions of this Section.

1.2 Documents

1.2.1 Documents to be submitted

In addition to those listed in Ch 7, Sec 4, Tab 1, the following documents are to be submitted for approval.

Table 1 : Documents to be submitted

No.	Description of the document (1)
1	Diagram of the ventilation systems serving cargo spaces and enclosed spaces adjacent to cargo spaces
3	Diagram of the gas measurement system for cargo pump rooms, pipe ducts and cofferdams adjacent to slop tanks
4	Diagram of water filling and draining systems for cofferdams
5	Diagram of discharge pumping and piping systems for slop tanks
(1) Diagrams are also to include, where applicable: <ul style="list-style-type: none"> the (local and remote) control and monitoring systems and automation systems the instructions for the operation and maintenance of the piping system concerned (for information). 	

1.2.2 Instruction manual

A manual is to be kept on board giving instructions for the carriage of contaminated sludge in slop tanks when the ship is in the dry cargo mode.

2 General requirements

2.1 Ventilation and gas detection

2.1.1 Ventilation

Cargo spaces and enclosed spaces adjacent to cargo spaces are to be capable of being mechanically ventilated. The mechanical ventilation may be provided by portable fans. See also Pt C, Ch 4, Sec 2, [2.1.2].

2.1.2 Gas detection

- An approved fixed gas warning system capable of monitoring flammable vapours is to be provided in cargo pump rooms and pipe ducts and cofferdams adjacent to slop tanks.
- Audible and visual alarms for the gas detection equipment are to be located on the bridge or in other suitable continually manned spaces.

2.2 Arrangement of cargo lines

2.2.1

- Where cargo wing tanks are provided, cargo oil lines below deck are to be installed inside these tanks. However, the Society may permit cargo oil lines to be placed in special ducts which are to be capable of being adequately cleaned and ventilated and to the satisfaction of the Society.

If connected to a cargo pump room, such ducts are to be considered as cargo pump rooms for the purposes of safety.

- Where cargo wing tanks are not provided, cargo oil lines below deck are to be placed in special ducts.

2.3 Cargo openings

2.3.1 Openings which may be used for cargo operations are not permitted in bulkheads and decks separating oil cargo spaces from other spaces not designed and equipped for the carriage of oil cargoes unless alternative approved means provide equivalent integrity.

2.4 Cofferdam filling and draining

2.4.1 Means are to be provided for filling the cofferdams surrounding the slop tanks with water and for draining them. See Ch 6, Sec 2, [1.1.5].

3 Slop tanks

3.1 Segregation of piping systems

3.1.1

- a) Pipes serving the slop tanks are to be segregated from other parts of the cargo pumping and piping system by means of isolation complying with b) or c) below.
- b) Arrangements to isolate slop tanks containing oil or oil residues from other cargo tanks are to consist of blank flanges which are to remain in position at all times when cargoes other than liquid cargoes referred to in Ch 7, Sec 1, [1.1.3] are carried.
- c) Means are to be provided for isolating the piping connecting the pump room with the slop tanks. The means of isolation are to consist of a valve followed by a spectacle flange or a spool piece with appropriate blank flanges. This arrangement is to be located adjacent to the slop tanks, but where this is unreasonable or impracticable, it may be located within the pump room directly after the piping penetrates the bulkhead.

3.2 Venting system

3.2.1 Slop tanks are to be provided with a separate venting system complying with the provisions of Ch 7, Sec 4, [4.2].

3.3 Discharge pumping and piping arrangement

3.3.1 A separate pumping and piping arrangement incorporating a manifold is to be provided for discharging the contents of the slop tanks directly to the open deck for disposal to shore reception facilities when the ship is in the dry cargo mode.

Part D

Service Notations

CHAPTER 7

OIL TANKERS AND FLS TANKERS

Section 1	General
Section 2	Ship Arrangement
Section 3	Hull and Stability
Section 4	Machinery and Cargo Systems
Section 5	Electrical Installations
Section 6	Fire Protection
Appendix 1	Devices to Prevent the Passage of Flame into the Cargo Tanks
Appendix 2	Design of Crude Oil Washing Systems
Appendix 3	Lists of Oils
Appendix 4	List of Products for which Part D, Chapter 8 and IBC Code do not Apply
Appendix 5	Accidental Oil Outflow Performance

Section 1 General

1 General

1.1 Application

1.1.1 Ships complying with the requirements of this Chapter are eligible for the assignment of the service notation **oil tanker**, as defined in Pt A, Ch 1, Sec 2, [4.4.2].

1.1.2 Ships dealt with in this Chapter are to comply with:

- Part A of the Rules
- NR216 Materials and Welding
- applicable requirements according to Tab 1
- requirements as defined in [1.1.3] and [1.1.4], as applicable.

Table 1 : Applicable requirements

Item		Ships having the additional service feature CSR	Ships not having the additional service feature CSR	
			Greater than or equal to 500 GT	Less than 500 GT
Ship arrangement	L ≥ 65 m	<ul style="list-style-type: none"> • NR606 (1) • Ch 7, Sec 2 	<ul style="list-style-type: none"> • Part B • Ch 7, Sec 2 	<ul style="list-style-type: none"> • NR566 • Ch 7, Sec 2
	L < 65 m	N.A.	<ul style="list-style-type: none"> • NR600 	<ul style="list-style-type: none"> • NR566 • Ch 7, Sec 2
Hull	L ≥ 65 m	<ul style="list-style-type: none"> • NR606 (1) (3) 	<ul style="list-style-type: none"> • Part B • Ch 7, Sec 3 	<ul style="list-style-type: none"> • Part B • Ch 7, Sec 3
	L < 65 m	N.A.	<ul style="list-style-type: none"> • NR600 	<ul style="list-style-type: none"> • NR600
Stability		<ul style="list-style-type: none"> • Part B • Ch 7, Sec 3 	<ul style="list-style-type: none"> • Part B • Ch 7, Sec 3 	<ul style="list-style-type: none"> • NR566 • Ch 7, Sec 3
Machinery and cargo systems		<ul style="list-style-type: none"> • Part C • Ch 7, Sec 4 (2) 	<ul style="list-style-type: none"> • Part C • Ch 7, Sec 4 (2) 	<ul style="list-style-type: none"> • NR566 • Ch 7, Sec 4 (2)
Electrical installations		<ul style="list-style-type: none"> • Part C • Ch 7, Sec 5 	<ul style="list-style-type: none"> • Part C • Ch 7, Sec 5 	<ul style="list-style-type: none"> • NR566 • Ch 7, Sec 5
Automation		<ul style="list-style-type: none"> • Part C 	<ul style="list-style-type: none"> • Part C 	<ul style="list-style-type: none"> • NR566
Fire protection, detection and extinction		<ul style="list-style-type: none"> • Part C • Ch 7, Sec 6 	<ul style="list-style-type: none"> • Part C • Ch 7, Sec 6 	<ul style="list-style-type: none"> • NR566 • Ch 7, Sec 6
<p>(1) Refer to the scope of application of NR606.</p> <p>(2) Ch 7, Sec 4 contains a table summarising the relaxations applying to certain service notations.</p> <p>(3) IACS Recommendation No.167 “Guidelines for the Identification of Vibration Issues and Recommended Remedial Measures on Ships” is to be applied on ships assigned additional service feature CSR.</p> <p>Note 1: NR566: Hull Arrangement, Stability and Systems for Ships less than 500 GT. NR600: Hull Structure and Arrangement for the Classification of Cargo Ships less than 65 m and Non Cargo Ships less than 90 m. NR606: Common Structural Rules for Bulk Carriers and Oil Tankers.</p>				

1.1.3 Service notation oil tanker

a) The requirements of this Chapter apply to ships having the service notation **oil tanker**, as defined in Pt A, Ch 1, Sec 2, [4.4.2]. They also apply to ships having the additional service feature **flash point > 60°C** and **asphalt carrier**, taking into account the specific provisions given in the different Sections.

Note 1: The specific provisions referred to in a) above do not apply to ships intended for the carriage of bulk cargoes at a temperature above the flash point of the product carried.

b) Departures from these requirements are given for ships that have the service notation **oil tanker-flash point > 60°C** and are intended only for the carriage of bulk cargoes at a temperature below and not within 15°C of their flash point.

c) Ch 7, Sec 4, [8] provides additional requirements for ships having the service notation **oil tanker-asphalt carrier**.

d) The list of substances the carriage in bulk of which is covered by the service notations **oil tanker**, **oil tanker- flash point > 60°C** and **oil tanker-asphalt carrier** is given in Ch 7, App 3, Tab 1.

1.1.4 Service notation FLS tanker

a) The requirements of this Chapter apply to ships having the service notation **FLS tanker**, as defined in Pt A, Ch 1, Sec 2, [4.4.5]. They also apply to ships having the additional service feature **FLS tanker-flash point > 60°C**, taking into account the specific provisions given in Ch 7, Sec 4.

Note 1: The specific provisions referred to in a) above do not apply to ships intended for the carriage of bulk cargoes at a temperature above the flash point of the product carried.

b) Ch 7, Sec 4, [9] provides additional requirements for ships having the service notations **FLS tanker** and **FLS tanker-flash point > 60°C** in the case of carriage of pollution category Z products.

c) The list of substances the carriage in bulk of which is covered by the service notations **FLS tanker** and **FLS tanker-flash point > 60°C** is given in Ch 7, App 4.

Note 2: The service notation **FLS tanker** does not cover cargoes containing 10% of benzene or more. Ships carrying such cargoes are to comply with the relevant requirements of Part D, Chapter 8.

Note 3: Where the provisions of this Chapter applicable to the service notation **oil tanker** and those applicable to the service notation **FLS tanker** are simultaneously complied with, a ship may be granted both service notations **oil tanker-FLS tanker** or **oil tanker-FLS tanker-flash point > 60°C**, as applicable.

1.2 Definitions

1.2.1 Cargo area

The cargo area is that part of the ship that contains cargo tanks as well as slop tanks, cargo pump rooms including pump rooms, cofferdams, ballast or void spaces adjacent to cargo tanks or slop tanks as well as deck areas throughout the entire length and breadth of the part of the ship above these spaces.

When independent tanks are installed in hold spaces, the cofferdams, ballast or void spaces at the after end of the aftermost hold space or at the forward end of the forwardmost hold space are excluded from the cargo area.

1.2.2 Cargo pump room

Cargo pump room is a space containing pumps and their accessories for the handling of products covered by the service notation granted to the ship.

1.2.3 Cargo service spaces

Cargo service spaces are spaces within the cargo area used for workshops, lockers and storerooms of more than 2 m² in area, intended for cargo handling equipment.

1.2.4 Cargo tank block

The cargo tank block is the part of the ship extending from the aft bulkhead of the aftmost cargo or slop tank to the forward bulkhead of the forward most cargo or slop tank, extending to the full depth and beam of the ship, but not including the area above the deck of the cargo or slop tank (See Fig 1).

Figure 1 : Cargo tank block definition

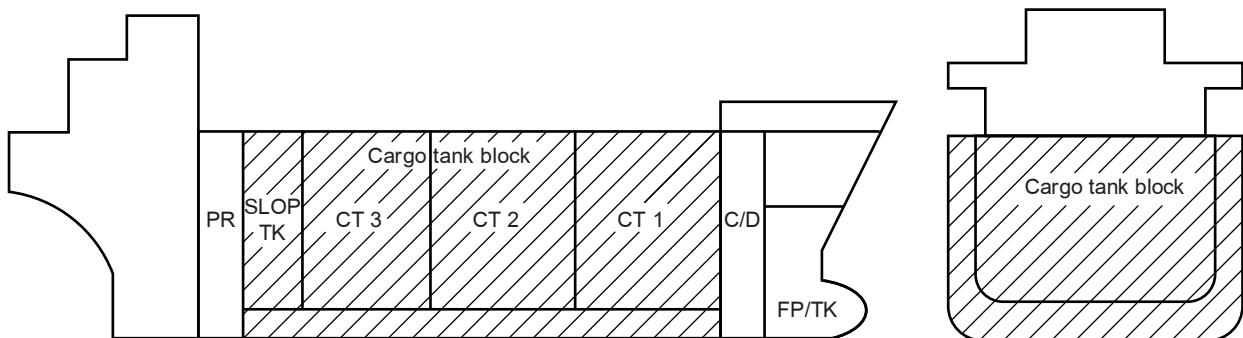

1.2.5 Clean ballast

Clean ballast means the ballast in a tank which since oil was last carried therein, has been so cleaned that the effluent therefrom if it were discharged from a ship which is stationary into clean calm water on a clear day would not produce visible traces of oil on the surface of the water or on adjoining shorelines or cause a sludge or emulsion to be deposited beneath the surface of the water or upon adjoining shorelines. If the ballast is discharged through an oil discharge monitoring and control system approved by the Society, evidence based on such a system to the effect that the oil content of the effluent did not exceed 15 parts per million is to be determinative that the ballast was clean, notwithstanding the presence of visible traces.

1.2.6 Cofferdam

For the purpose of Ch 7, Sec 2, [2], a cofferdam is an isolating space between two adjacent steel bulkheads or decks. It is to meet the following criteria:

- a) the minimum distance between the two bulkheads or decks is to be sufficient for safe access and inspection.
- b) in order to meet the single failure principle, in the particular case when a corner-to-corner situation occurs, this principle may be met by welding a diagonal plate across the corner.

1.2.7 Crude oil

Crude oil is any oil occurring naturally in the earth whether or not treated to render it suitable for transportation and includes:

- a) *crude oil from which certain distillate fractions have been removed, and*
- b) *crude oil to which certain distillate fractions may have been added.*

1.2.8 Crude oil tanker

Crude oil tanker means an oil tanker engaged in the trade of carrying crude oil.

1.2.9 Hold space

Hold space is the space enclosed by the ship's structure in which an independent cargo tank is fitted

1.2.10 Fuel oil

Fuel oil means any oil used as fuel in connection with the propulsion and auxiliary machinery of the ship on which such oil is carried.

1.2.11 Oil-like substances

Oil-like substances are those substances listed in Ch 7, App 3, Tab 2.

1.2.12 Oil mixture

Oil mixture means a mixture with any oil content.

1.2.13 Product carrier

Product carrier means an oil tanker engaged in the trade of carrying oil other than crude oil.

1.2.14 Pump room

Pump room is a space, located in the cargo area, containing pumps and their accessories for the handling of ballast and fuel oil, or cargoes other than those covered by the service notation granted to the ship.

1.2.15 Segregated ballast

Segregated ballast means the ballast water introduced into a tank which is completely separated from the cargo oil and fuel oil system and which is permanently allocated to the carriage of ballast or to the carriage of ballast or cargoes other than oil or noxious substances as variously defined in Part D, Chapter 7 and Part D, Chapter 8.

1.2.16 Slop tank

Slop tank means a tank specifically designated for the collection of tank draining, tank washings and other oily mixtures.

1.2.17 Void space

Void space is an enclosed space in the cargo area external to a cargo tank, except for a hold space, ballast space, fuel oil tank, cargo pump room, pump room, or any space normally used by personnel.

Section 2 Ship Arrangement

Symbols

L_{LL} : Load line length, in m, defined in Pt B, Ch 1, Sec 3, [2.1.2].

1 General

1.1 Application

1.1.1 Except otherwise specified, the requirements of this Section apply to the ships having one of the following service notations:

- oil tanker
- oil tanker, flash point > 60°C
- oil tanker, asphalt carrier
- FLS tanker
- FLS tanker, flash point > 60°C.

1.1.2 The requirements of this Section apply to ships having a propelling machinery located at the aft part of the ship. Ships with other arrangements are to be specially considered by the Society.

1.2 Documents to be submitted

1.2.1 Tab 1 are to be submitted for approval.

Table 1 : Documents to be submitted

No.	Description of the document
1	General arrangement drawing with indication of: <ul style="list-style-type: none"> • access and openings • capacity and size of the cargo tanks, slop tanks and ballast tanks
2	Diagram of the mechanical and natural ventilation with indication of the ventilation inlets and outlets

2 General arrangement of the ship with regard to fire prevention and crew safety

2.1 Location and separation of spaces

2.1.1 Application

- a) The provisions of [2.1.2] to [2.1.5] apply only to ships having the service notations **oil tanker** or **FLS tanker**.
- b) Ships having one of the following service notations:
- oil tanker, flash point > 60°C
 - oil tanker, asphalt carrier
 - FLS tanker, flash point > 60°C
- are to comply with the provisions of [2.1.6].

2.1.2 Cargo tank area

- a) Fore and aft peaks are not to be used as cargo tanks.
- b) Double bottom tanks adjacent to cargo tanks are not to be used as oil fuel tanks.
- c) On ships having the service notation **oil tanker** or **FLS tanker** without the additional service feature **flash point > 60°C** or **asphalt carrier**, fuel tanks located with a common boundary to cargo or slop tanks are not to be situated within, nor extend partly into, the cargo tank block. Such tanks may, however, be situated aft and/or forward of the cargo tank block. They may be accepted when located as independent tanks on open deck in the cargo area subject to spill and fire safety considerations. The arrangement of independent fuel tanks and associated fuel piping systems, including the pumps, may be as for fuel tanks and associated fuel piping systems located in the machinery spaces. For electrical equipment, requirements applicable to hazardous area classification must however be met.

2.1.3 Cargo pump rooms

- a) The cargo pump rooms are to be separated from the other spaces of the ship by oiltight bulkheads and are not to have, in particular, any direct communications with the machinery spaces.
- b) Where glazed ports are provided on the bulkhead separating the cargo pump room from the machinery compartment, they are to satisfy the following conditions:
 - they are to be efficiently protected from mechanical damage
 - strong covers are to be permanently secured on the machinery compartment side
 - glazed ports are to be so constructed that glass and sealing are not impaired by the working of the ship
 - the glazed ports are to be so constructed as to maintain the structural integrity and the bulkheads resistance to fire and smoke.

2.1.4 *Cargo pump rooms, cargo tanks, slop tanks and cofferdams are to be positioned forward of machinery spaces. However, oil fuel bunker tanks need not be forward of machinery spaces.*

Cargo tanks and slop tanks are to be isolated from machinery spaces by cofferdams, cargo pump rooms, oil bunker tanks or ballast tanks.

Pump-rooms containing pumps and their accessories for ballasting those spaces situated adjacent to cargo tanks and slop tanks and pumps for oil fuel transfer are to be considered as equivalent to a cargo pump room within the context of this article provided that such pump rooms have the same safety standard as that required for cargo pump rooms. Pump rooms intended solely for ballast or oil fuel transfer, however, need not comply with the requirements of Ch 7, Sec 6, [4.2].

The lower portion of the pump room may be recessed into machinery spaces of category A to accommodate pumps, provided that the deck head of the recess is in general not more than one third of the moulded depth above the keel, except that in the case of ships of not more than 25000 tonnes deadweight, where it can be demonstrated that for reasons of access and satisfactory piping arrangements this is impracticable, the Society may permit a recess in excess of such height, but not exceeding one half of the moulded depth above the keel.

Note 1: Pump rooms intended solely for ballast transfer need not comply with the requirements of Ch 7, Sec 4, [3.5.2]. The requirements of Ch 7, Sec 4, [3.5.2] are only applicable to the pump rooms, regardless of their location, where pumps for cargo, such as cargo pumps, stripping pumps, pumps for slop tanks, pumps for COW or similar pumps are provided.

“Similar pumps” includes pumps intended for transfer of fuel oil having a flashpoint of less than 60°C. Pump-rooms intended for transfer of fuel oil having a flashpoint of not less than 60°C need not comply with the requirements of Ch 7, Sec 4, [3.5.2].

2.1.5 Accommodation spaces, service spaces and control stations

- a) *Accommodation spaces, main cargo control stations, control stations and service spaces (excluding isolated cargo handling gear lockers) are to be positioned aft of cargo tanks, slop tanks, and spaces which isolate cargo or slop tanks from machinery spaces but not necessarily aft of the fuel oil bunker tanks and ballast tanks, but be arranged in such a way that a single failure of a deck or bulkhead not permit the entry of gas or fumes from the cargo tanks into an accommodation space, main cargo control stations, control station, or service spaces. A recess provided in accordance with [2.1.4] need not be taken into account when the position of these spaces is being determined.*
- b) *However, where deemed necessary, the Society may permit accommodation spaces, main cargo control stations, control stations, and service spaces forward of the cargo tanks, slop tanks and spaces which isolate cargo and slop tanks from machinery spaces, but not necessarily forward of fuel oil bunker tanks or ballast tanks. Machinery spaces, other than those of category A, may be permitted forward of the cargo tanks and slop tanks provided they are isolated from the cargo tanks and slop tanks by cofferdams, cargo pump rooms, fuel oil bunker tanks or ballast tanks. All of the above spaces are to be subject to an equivalent standard of safety and appropriate availability of fire-extinguishing arrangements being provided to the satisfaction of the Society. Accommodation spaces, main cargo control spaces, control stations and service spaces are to be arranged in such a way that a single failure of a deck or bulkhead not permit the entry of gas or fumes from the cargo tanks into such spaces. In addition, where deemed necessary for the safety or navigation of the ship, the Society may permit machinery spaces containing internal combustion machinery not being main propulsion machinery having an output greater than 375 kW to be located forward of the cargo area provided the arrangements are in accordance with the provisions of this paragraph.*
- c) *Where the fitting of a navigation position above the cargo area is shown to be necessary, it is to be for navigation purposes only and it is to be separated from the cargo tank deck by means of an open space with a height of at least 2 m. The fire protection of such navigation position is to be in addition as required for control spaces in Ch 7, Sec 6 and other provisions, as applicable, of this Chapter.*
- d) *Means be provided to keep deck spills away from the accommodation and service areas. This may be accomplished by provision of a permanent continuous coaming of a height of at least 300 mm, extending from side to side. Special consideration be given to the arrangements associated with stern loading.*

Note 1: The provisions of paragraph d) above also apply to bow and stern cargo loading stations.

- e) *Exterior boundaries of superstructures and deckhouses enclosing accommodation and including any overhanging decks which support such accommodation, is to be constructed of steel and insulated to A-60 standard for the whole of the portions which face the cargo area and on the outward sides for a distance of 3 m from the end boundary facing the cargo area. The distance of 3 m is to be measured horizontally and parallel to the middle line of the ship from the boundary which faces the*

cargo area at each deck level. In the case of the sides of those superstructures and deckhouses, such insulation is to be carried up to the underside of the deck of the navigation bridge.

Note 2: Service spaces and control stations (except the wheelhouse) located in superstructures and deckhouses enclosing accommodation are to comply with the provisions of item e).

- f) The location and arrangement of the room where foods are cooked are to be selected such as to minimize the risk of fire.
- g) Paint lockers, regardless of their use, cannot be located above the tanks and spaces defined in item a).

2.1.6 Case of ships having the service notations oil tanker, flash point > 60°C, oil tanker, asphalt carrier or FLS tanker, flash point > 60°C

On ships having one of the following service notations:

- **oil tanker, flash point > 60°C**
- **oil tanker, asphalt carrier**
- **FLS tanker, flash point > 60°C,**

the location and separation of spaces is not required to comply with requirements [2.1.2] to [2.1.5].

However, the following provisions are to be complied with:

- a) Tanks containing cargo or cargo residues are to be segregated from accommodation, service and machinery spaces, tanks containing drinking water and stores for human consumption by means of a cofferdam or similar space.
- b) Double bottom tanks adjacent to cargo tanks are not to be used as fuel oil tanks.
- c) Means are to be provided to keep deck spills away from accommodation and service areas.

2.2 Access and openings

2.2.1 Application

- a) Ships with the service notation **oil tanker ESP** of less than 500 gross tonnage, and ships with the service notation **oil tanker** or **FLS tanker** are to comply with the provisions of [2.2.2] to [2.2.6].
- b) Ships having one of the following service notations:
 - **oil tanker, flash point > 60°C**
 - **oil tanker, asphalt carrier**
 - **FLS tanker, flash point > 60°C,**are to comply with the provisions of [2.2.7].
- c) Ships with the service notation **oil tanker ESP** of 500 gross tonnage and over, are to comply with the provisions of [2.2.2], [2.2.4], [2.2.5] and [2.2.6] and with the International Convention for the Safety of Life at Sea, 1974, as amended, Chapter II-1, Part A-1, Regulation 3-6, for details and arrangements of openings and attachments to the hull structure.

2.2.2 Access and openings to accommodation spaces, service spaces, control stations and machinery spaces

- a) *Except as permitted in paragraph b), access doors, air inlets and openings to accommodation spaces, service spaces, control stations and machinery spaces are not to face the cargo area. They are to be located on the transverse bulkhead not facing the cargo area or on the outboard side of the superstructure or deckhouse at a distance of at least 4% of the length of the ship but not less than 3 m from the end of the superstructure or deckhouse facing the cargo area. This distance need not exceed 5 m.*
- b) *The Society may permit access doors in boundary bulkheads facing the cargo area or within the 5 m limits specified in paragraph a), to main cargo control stations and to such service spaces used as provision rooms, store-rooms and lockers, provided they do not give access directly or indirectly to any other space containing or providing for accommodation, control stations or service spaces such as galleys, pantries or workshops, or similar spaces containing sources of vapour ignition. The boundary of such a space is to be insulated to "A-60" class standard, with the exception of the boundary facing the cargo area. Bolted plates for the removal of machinery may be fitted within the limits specified in paragraph a). Wheelhouse doors and windows may be located within the limits specified in paragraph a) so long as they are designed to ensure that the wheelhouse can be made rapidly and efficiently gas tight and vapour tight.*

Note 1: An access to a deck foam system room (including the foam tank and the control station) can be permitted within the limits mentioned in paragraph a), provided that the conditions listed in paragraph b) are satisfied and that the door is located flush with the bulkhead.

Note 2: The navigating bridge door and windows are to be tested for gas tightness. If a water hose test is applied, the following test conditions are deemed acceptable by the Society:

- nozzle diameter: minimum 12 mm
 - water pressure just before the nozzle: not less than 2 bar,
 - distance between the nozzle and the doors or windows: maximum 1,5 m.
- c) *Windows and sidescuttles facing the cargo area and on the side of the superstructures and deckhouses within the limits specified in paragraph a) are to be of the fixed (non-opening) type. Such windows and sidescuttles, except wheelhouse windows, are to be constructed to "A-60" class standard.*
 - d) Air intakes and air outlets of machinery spaces are to be located as far aft as practicable and, in any case, outside the limits stated in a) above.

- e) Where the ship is designed for bow or stern loading and unloading, entrance, air inlets and openings to accommodation, service and machinery spaces and control stations are not to face the cargo shore connection location of bow or stern loading or unloading arrangements. They are to be located on the outboard side of the superstructure or deckhouse at a distance of at least 4% of the length of the ship but not less than 3 m from the end of the deckhouse facing the cargo shore connection location of the bow or stern loading and unloading arrangements. This distance, however, need not exceed 5 m. Sidescuttles facing the shore connection location and on the sides of the superstructure or deckhouse within the distance mentioned above are to be of the fixed (non-opening) type. In addition, during the use of the bow or stern loading and unloading arrangements, all doors, ports and other openings on the corresponding superstructure or deckhouse side are to be kept closed.

Note 3: Where, in the case of small ships, compliance with the provisions of paragraph e) is not possible, the Society may permit departures.

2.2.3 Access to spaces in the cargo area

- a) Access to cofferdams, ballast tanks, cargo tanks and other compartments in the cargo area is to be direct from the open deck and such as to ensure their complete inspection. Access to double bottom compartments may be through a cargo pump room, pump room, deep cofferdam, pipe tunnel or similar compartments, subject to consideration of ventilation aspects.

Safe access to cofferdams, ballast tanks, cargo tanks and other compartments in the cargo area is to be direct from the open deck and such as to ensure their complete inspection. Safe access to double bottom compartments or to forward ballast tanks may be from a pump-room, deep cofferdam, pipe tunnel, double hull compartment or similar compartment not intended for the carriage of oil or hazardous cargoes.

Note 1: Access manholes to forward gas dangerous spaces are permitted from an enclosed gas-safe space provided that:

- their closing means are gastight and
- a warning plate is provided in their vicinity to indicate that the opening of the manholes is only permitted after checking that there is no flammable gas inside the compartment in question.

Note 2: Unless other additional arrangements provided to facilitate their access are considered satisfactory by the Society, the double bottom tanks are to be provided with at least two separate means of access complying with a) above.

- b) For access through horizontal openings, hatches or manholes, the dimensions are to be sufficient to allow a person wearing a self-contained air-breathing apparatus and protective equipment to ascend or descend any ladder without obstruction and also provide a clear opening to facilitate the hoisting of an injured person from the bottom of the compartment. The minimum clear opening is to be not less than 600 mm x 600 mm.
- c) For access through vertical openings, or manholes, in swash bulkheads, floors, girders and web frames providing passage through the length and breadth of the compartment, the minimum opening is to be not less than 600 mm x 800 mm at a height of not more than 600 mm from the bottom shell plating unless gratings or other foot holds are provided.
- d) For oil tankers of less than 5000 t deadweight smaller dimensions may be approved by the Society in special circumstances, if the ability to traverse such openings or to remove an injured person can be proved to the satisfaction of the Society.
- For oil tankers of less than 5,000 tonnes deadweight, the Society may approve, in special circumstances, smaller dimensions for the openings referred to in paragraphs a) and b), if the ability to traverse such openings or to remove an injured person can be proved to the satisfaction of the Society.*
- e) Access ladders of cargo tanks are to be fitted with handrails and to be securely attached to the tank structure. They are not to be fitted vertically, unless justified by the size of the tanks. Rest platforms are to be provided at suitable intervals of not more than 10 m.

2.2.4 Access to the pipe tunnels

- a) The pipe tunnels in the double bottom are to comply with the following requirements:
- 1) they are not to communicate with the engine room,
 - 2) provision is to be made for at least two exits to the open deck arranged at a maximum distance from each other. One of these exits fitted with a watertight closure may lead to the cargo pump room.
- b) Where there is permanent access from a pipe tunnel to the main pump room, a watertight door is to be fitted complying with the requirements of Pt B, Ch 2, Sec 1, [6] and in addition with the following:
- 1) in addition to the bridge operation, the watertight door is to be capable of being manually closed from outside the main pump room entrance,
 - 2) the watertight door is to be kept closed during normal operations of the ship except when access to the pipe tunnel is required.

Note 1: A notice is to be affixed to the door to the effect that it may not be left open.

2.2.5 Access to the forecastle spaces

Access to the forecastle spaces containing sources of ignition may be permitted through doors facing cargo area provided the doors are located outside hazardous areas as defined in Ch 7, Sec 5.

2.2.6 Access to the bow

Every tanker is to be provided with the means to enable the crew to gain safe access to the bow even in severe weather conditions. Such means of access are to be approved by the Society.

Note 1: The Society accepts means of access complying with the Guidelines for safe access to tanker bows adopted by the Marine Safety Committee of IMO by Resolution MSC.62(67).

2.2.7 Case of ships having the service notations oil tanker, flash point > 60°C, oil tanker, asphalt carrier or FLS tanker, flash point > 60°C

On ships having one of the following service notations:

- **oil tanker, flash point > 60°C**
- **oil tanker, asphalt carrier**
- **FLS tanker, flash point > 60°C,**

the access and openings are not required to comply with the provisions of [2.2.2]. However, the access doors, air inlets and openings to accommodation spaces, service spaces and control stations are not to face the cargo area.

2.3 Ventilation

2.3.1 Application

- a) The requirements of [2.3.2] to [2.3.5] apply only to ships having the service notations **oil tanker** or **FLS tanker**.
- b) Ships having one of the following service notations:
 - **oil tanker, flash point > 60°C**
 - **oil tanker, asphalt carrier**
 - **FLS tanker, flash point > 60°C,**

are to comply with the provisions of [2.3.6].

2.3.2 General

- a) Enclosed spaces within the cargo area are to be provided with efficient means of ventilation. Unless otherwise specified, portable means are permitted for that purpose. Ventilation fans are to be of non sparking construction according to Pt C, Ch 4, Sec 1, [3.32].
- b) *Ventilation inlets and outlets, especially for machinery spaces, are to be situated as far aft as practicable. Due consideration in this regard is to be given when the ship is equipped to load or discharge at the stern. Sources of ignition such as electrical equipment are to be so arranged as to avoid an explosion hazard.*

2.3.3 Ventilation of cargo pump rooms

- a) Ventilation exhaust ducts are to discharge upwards in locations at least 3 m measured horizontally from any ignition source and from any ventilation intake and opening to non-hazardous spaces.
- b) Ventilation intakes are to be so arranged as to minimize the possibility of recycling hazardous vapours from ventilation discharge openings.
- c) The ventilation ducts are not to be led through gas safe spaces, cargo tanks or slop tanks.
- d) See also Ch 7, Sec 4, [3.5.1].

2.3.4 Ventilation of other pump rooms

- a) Ventilation of pump rooms containing:
 - ballast pumps serving spaces adjacent to cargo or slop tanks
 - oil fuel pumps,is to comply with paragraphs a) to c) of [2.3.3] and a) of Ch 7, Sec 4, [3.5.1].
- b) The ventilation intakes of the pump rooms referred to in a) are to be located at a distance of not less than 3 m from the ventilation outlets of cargo pump rooms.

2.3.5 Ventilation of double hull and double bottom spaces

Double hull and double bottom spaces are to be fitted with suitable connections for the supply of air.

2.3.6 Case of ships having the service notations oil tanker, flash point > 60°C, oil tanker, asphalt carrier or FLS tanker, flash point > 60°C

On ships having one of the following service notations:

- oil tanker, flash point > 60°C
- oil tanker, asphalt carrier
- FLS tanker, flash point > 60°C,

the ventilation is not required to comply with requirements [2.3.2] to [2.3.5]. However, the following provisions apply:

- spaces located within the cargo area are to be efficiently ventilated. Portable means of ventilation are permitted
- ventilation of the cargo pump room is to comply with [2.3.3].

3 General arrangement of the ship with regard to pollution prevention

3.1 Application

3.1.1 Service notations

The requirements of the present Article apply only to ships having one of the following notations:

- oil tanker
- oil tanker, flash point > 60°C
- oil tanker, asphalt carrier.

3.1.2 Tonnage

Unless otherwise specified, the requirements of the present Article apply only to ships of 150 gross tonnage and above.

3.2 Protection of the cargo tank length in the event of grounding or collision

3.2.1 Application

The requirements of the present sub-article apply to ships of 600 tons deadweight and above.

3.2.2 General

- a) The design and construction of oil tankers is to pay due regard to the general safety aspects including the need for maintenance and inspections of wing and double bottom tanks or spaces.
- b) *Oil is not to be carried in any space extending forward of a collision bulkhead located in accordance with Pt B, Ch 2, Sec 1, [3]. An oil tanker that is not required to have a collision bulkhead in accordance with that regulation is not to carry oil in any space extending forward of the transverse plane perpendicular to the centreline that is located as if it were a collision bulkhead located in accordance with that regulation.*

3.2.3 Case of ships of 5000 tons deadweight and above

On oil tankers of 5000 tons deadweight and above, the entire cargo tank length is to be protected by ballast tanks or spaces other than cargo and fuel oil tanks as follows:

a) *Wing tanks or spaces*

Wing tanks or spaces are to extend either for the full depth of the ship's side or from the top of the double bottom to the uppermost deck, disregarding a rounded gunwale where fitted. They are to be arranged such that the cargo tanks are located inboard of the moulded line of the side shell plating, nowhere less than the distance w which, as shown in Fig 1 is measured at any cross-section at right angles to the side shell, as specified below:

$$w = 0,5 + \frac{DW}{20000} \text{ (m)}$$

or w = 2,0 m, whichever is the lesser.

The minimum value of w = 1,0 m.

b) *Double bottom tanks or spaces*

At any cross-section, the depth of each double bottom tank or compartment is to be such that the distance h between the bottom of the cargo tanks and the moulded line of the bottom shell plating measured at right angles to the bottom shell plating, as shown in Fig 1 is not less than specified below:

- *B/15 (m), or*
- *2,0 m, whichever is the lesser.*

The minimum value of h = 1,0 m.

Figure 1 : Cargo tank boundary lines

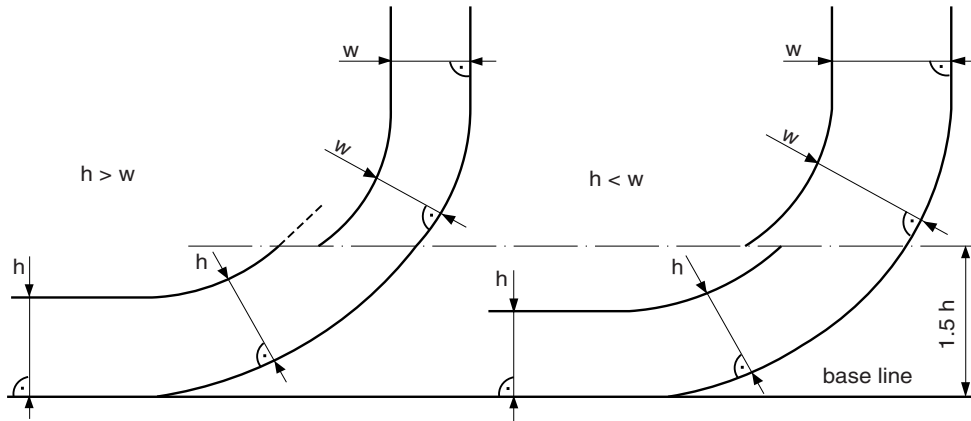

Note 1: Double bottom tanks or spaces as required by the above paragraph may be dispensed with, provided that the design of the tanker is such that the cargo and vapour pressure exerted on the bottom shell plating forming a single boundary between the cargo and the sea does not exceed the external hydrostatic water pressure, as expressed by the following formula:

$$f \times h_c \times \rho_c \times g + 100\Delta_p \leq d_n \times \rho_s \times g$$

where:

- h_c : Height of cargo in contact with the bottom shell plating, in metres
- ρ_c : Maximum cargo density, in t/m^3
- d_n : Minimum operating draught under any expected loading conditions, in metres
- ρ_s : Density of seawater, in t/m^3
- Δ_p : Maximum set pressure of pressure/vacuum valve provided for the cargo tanks, in bars
- f : Safety factor = 1,1
- g : Standard acceleration of gravity (9,81 m/s^2).

Any horizontal partition necessary to fulfil the above requirements are to be located at a height of not less than $B/6$ or 6 m, whichever is the lesser, but not more than $0,6D$, above the baseline where D is the moulded depth amidships.

The location of wing tanks or spaces is to be as defined in paragraph a) above except that, below a level $1,5h$ above the baseline where h is as defined above, the cargo tank boundary line may be vertical down to the bottom plating, as shown in Fig 2.

Figure 2 : Cargo tank boundary lines

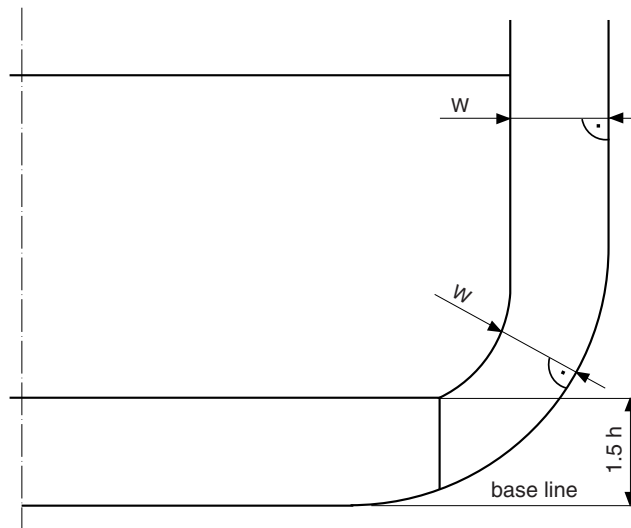

c) Turn of the bilge area or at locations without a clearly defined turn of the bilge

Where the distance h and w are different, the distance w is to have preference at levels exceeding $1,5h$ above baseline as shown in Fig 1.

d) Aggregate capacity of the ballast tanks

On crude oil tankers of 20000 t deadweight and above and product carriers of 30000 t deadweight and above, the aggregate capacity of wing tanks, double bottom tanks, forepeak tanks and afterpeak tanks is to be not less than the capacity of segregated ballast tanks necessary to meet the requirements of [3.3.2]. Wing tanks or compartments and double bottom tanks used to meet the requirements of [3.3.2] are to be located as uniformly as practicable along the cargo tank length. Additional segregated ballast capacity provided for reducing longitudinal hull girder bending stress, trim, etc., may be located anywhere within the ship.

In calculating the aggregate capacity, the following is to be taken into account:

- the capacity of engine-room ballast tanks is to be excluded from the aggregate capacity of ballast tanks
- the capacity of ballast tanks located inboard of double hull is to be excluded from the aggregate capacity of ballast tanks
- spaces such as void spaces located in the double hull within the cargo tank length should be included in the aggregate capacity of ballast tanks

Any ballast carried in localised inboard extensions, indentation or recesses of the double hull, such as bulkhead stools, should be considered as excess ballast above the minimum requirement for segregated ballast capacity according to [3.3.2].

- e) Suction wells in cargo tanks may protube into the double bottom below the boundary line defined by the distance h provided that such wells are as small as practicable and the distance between the well bottom and bottom shell plating is not less than $0,5 h$.
- f) Ballast and cargo piping is to comply with the provisions of Ch 7, Sec 4, [2.3.7] and Ch 7, Sec 4, [3.4.1].

Note 2: Other methods of design and construction of oil tankers may also be accepted as alternatives to the requirements prescribed in items a) to f), provided that such methods ensure at least the same level of protection against oil pollution in the event of collision or stranding and are approved in principle by the Society.

The Society will accept the methods of design and construction described in IMO Resolution MEPC.110(49).

3.2.4 Case of ships of less than 5000 tons deadweight

Oil tankers of less than 5000 tons deadweight are to:

- a) at least be fitted with double bottom tanks or spaces having such a depth that the distance h specified in [3.2.3] b) complies with the following:

$$h = B/15 \text{ (m)}$$

with a minimum value of $h = 0,76 \text{ m}$;

in the turn of the bilge area and at locations without a clearly defined turn of bilge, the cargo tank boundary line is to run parallel to the line of the midship flat bottom as shown in Fig 3; and

- b) be provided with cargo tanks so arranged that the capacity of each cargo tank does not exceed 700 m^3 unless wing tanks or spaces are arranged in accordance with [3.2.3] a) complying with the following:

$$w = 0,4 + \frac{2,4 \text{ DW}}{20000} \text{ (m)}$$

with a minimum value of $w = 0,76 \text{ m}$.

Figure 3 : Cargo tank boundary lines

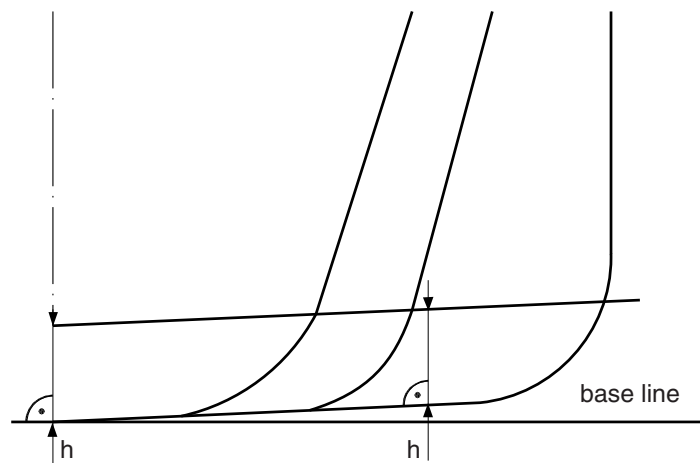

3.3 Segregation of oil and water ballast

3.3.1 General

- a) In oil tankers of 150 gross tonnage and above, no ballast water is to be carried in any oil fuel tank.
- b) Every crude oil tanker of 20000 tons deadweight and above and every product carrier of 30000 tons deadweight and above are to be provided with segregated ballast tanks and are to comply with requirements [3.3.2] and [3.3.3].

3.3.2 Capacity of the segregated ballast tanks

The capacity of the segregated ballast tanks is to be so determined that the ship may operate safely on ballast voyages without recourse to the use of cargo tanks for water ballast. In all cases, however, the capacity of segregated ballast tanks is to be at least such that, in any ballast condition at any part of the voyage, including the conditions consisting of lightweight plus segregated ballast only, the ship's draughts and trim can meet each of the following requirements:

- a) the moulded draught amidships, d_m , in metres (without taking into account any ship's deformation) is to be not less than:
 $d_m = 2,0 + 0,02 L_{LL}$
- b) the draughts at the forward and after perpendicular are to correspond to those determined by the draught amidships d_m as specified above, in association with the trim by the stern of not greater than $0,015L_{LL}$, and
- c) in any case the draught at the after perpendicular is to be not less than that which is necessary to obtain full immersion of the propeller(s).

Refer also to paragraph d) of [3.2.3].

Note 1: In case of oil tankers less than 150 metres in length, the above formulae may be replaced by those set out in Appendix I to the Unified Interpretations of Annex I of MARPOL 73/78.

3.3.3 Carriage of ballast water in cargo tanks

- a) In no case is ballast water to be carried in cargo tanks, except:
- 1) on those rare voyages when weather conditions are so severe that, in the opinion of the Master, it is necessary to carry additional ballast water in cargo tanks for the safety of the ship, and
 - 2) in exceptional cases where the particular character of the operation of an oil tanker renders it necessary to carry ballast water in excess of the quantity required under [3.3.3], provided that such operation of the oil tanker falls under the category of exceptional cases.

Note 1: Exceptional cases are defined in the Unified Interpretations of Annex I of MARPOL 73/78

Such additional ballast water is to be processed and discharged in compliance with regulation 34 of Annex I of MARPOL 73/78 and an entry is to be made in the Oil Record Book Part II referred to in regulation 36 of that Annex.

- b) In the case of crude oil tankers, the additional ballast permitted in paragraph a) above is to be carried in cargo tanks only if such tanks have been crude oil washed in accordance with [3.5] before departure from an oil unloading port or terminal.

3.4 Accidental oil outflow performance

3.4.1 Oil tankers are to comply with the requirements of the Regulation 23 of Annex I to Marpol Convention, as amended.

3.5 Cleaning of cargo tanks

3.5.1 General

- a) Adequate means are to be provided for cleaning the cargo tanks.

Note 1: This provision does not apply to ships of less than 150 gross tonnage provided the conditions stated in [3.6.1] are fulfilled.

- b) Every crude oil tanker of 20000 tons deadweight and above is to be fitted with a cargo tank cleaning system using crude oil washing complying with the following requirements. Unless such oil tanker carries crude oil which is not suitable for crude oil washing, the oil tanker is to operate the system in accordance with those requirements.

The crude oil washing installation and associated equipment and arrangements are to comply with the requirements of Ch 7, App 2.

3.5.2 Ballasting of cargo tanks

With respect to the ballasting of cargo tanks, sufficient cargo tanks are to be crude oil washed prior to each ballast voyage in order that, taking into account the tanker's trading pattern and expected weather conditions, ballast water is put only into cargo tanks which have been crude oil washed.

3.5.3 Operations and Equipment Manual

Every oil tanker operating with crude oil washing systems is to be provided with an Operations and Equipment Manual detailing the system and equipment and specifying operational procedures. Such a Manual is to be to the satisfaction of the Society and is to contain all the information set out in Ch 7, App 2. If an alteration affecting the crude oil washing system is made, the Operating and Equipment Manual is to be revised accordingly.

3.6 Retention of oil on board - Slop tanks

3.6.1 Application

- a) The provisions of requirements [3.6.2] to [3.6.4] do not apply to ships of less than 150 gross tonnage for which the control of discharge of oil under Ch 7, Sec 4, [5.2.1] is to be effected by the retention of oil on board with subsequent discharge of all contaminated washings to reception facilities, unless adequate arrangements are made to ensure that any effluent which is allowed to be discharged into the sea is effectively monitored to ensure that the provisions of Ch 7, Sec 4, [5.2.1] are complied with.

Note 1: The provisions of requirements [3.6.2] to [3.6.4] may be waived for any oil tanker which engages exclusively on both voyages of 72 hours or less in duration and within 50 miles from the nearest land, provided that the oil tanker is engaged exclusively in trades between ports or terminals within a State Party to MARPOL 73/78 Convention. Any such waiver is to be subject to the requirements that the oil tanker is to retain on board all oily mixtures for subsequent discharge to reception facilities and to the determination by the Administration that facilities available to receive such oily mixtures are adequate.

- b) The provisions of Ch 7, Sec 4, [5] are also to be complied with.

3.6.2 General

- a) Adequate means are to be provided for transferring the dirty ballast residue and tank washings from the cargo tanks into a slop tank approved by the Society.
- b) Arrangements are to be provided to transfer the oily waste into a slop tank or combination of slop tanks in such a way that any effluent discharged into the sea comply with the provisions of Ch 7, Sec 4, [5.2].

3.6.3 Capacity of slop tanks

The arrangement of the slop tank or combination of slop tanks is to have a capacity necessary to retain the slop generated by tank washings, oil residues and dirty ballast residues. The total capacity of the slop tank or tanks is not to be less than 3% of the oil carrying capacity of the ship, except that the Society may accept:

- a) 2% for oil tankers where the tank washing arrangements are such that once the slop tank or tanks are charged with washing water, this water is sufficient for tank washing and, where applicable, for providing the driving fluid for eductors, without the introduction of additional water into the system
- b) 2% where segregated ballast tanks are provided in accordance with [3.3], or where a cargo tank cleaning system using crude oil washing is fitted in accordance with [3.5]. This capacity may be further reduced to 1,5% for oil tankers where the tank washing arrangements are such that once the slop tank or tanks are charged with washing water, this water is sufficient for tank washing and, where applicable, for providing the driving fluid for eductors, without introduction of additional water into the system.

Oil tankers of 70 000 tons deadweight and above are to be fitted with at least two slop tanks.

3.6.4 Design of slop tanks

Slop tanks are to be so designed particularly in respect of the position of inlets, outlets, baffles or weirs where fitted, so as to avoid excessive turbulence and entrainment of oil or emulsion with the water.

3.7 Deck spills

3.7.1 Means are to be provided to keep deck spills away from the accommodation and service areas. This may be accomplished by providing a permanent continuous coaming of a suitable height extending from side to side.

Where gutter bars are installed on the weather decks of oil tankers in way of cargo manifolds and are extended aft as far as the aft bulkhead of superstructures for the purpose of containing cargo spills on deck during loading and discharge operations, the free surface effects caused by containment of a cargo spill during liquid transfer operations or of boarding seas while underway are to be considered with respect to the vessel's available margin of positive initial stability (GM₀).

Where the gutter bars installed are higher than 300 mm, they are to be treated as bulwarks with freeing ports arranged in accordance with Pt B, Ch 11, Sec 12, [6] and provided with effective closures for use during loading and discharge operations. Attached closures are to be arranged in such a way that jamming is prevented while at sea, enabling the freeing ports to remain effective.

An assessment of the initial stability (GM₀) for compliance with the relevant intact stability requirements taking into account the free surface effect caused by liquids contained by the gutter bars is to be undertaken on:

- tankers having cargo tanks exceeding 60% of the vessel's maximum beam at midships regardless of gutter bar height
- ships without deck camber
- ships where the height of the installed gutter bars exceeds the camber.

3.8 Pump-room bottom protection

3.8.1 This Article is applicable to oil tankers of 5000 tons deadweight and above.

3.8.2 The pump-room is to be provided with a double bottom such that at any cross-section the depth of each double bottom tank or space is to be such that the distance h between the bottom of the pump-room and the ship's base line measured at right angles to the ship's base line is to be not less than the lesser of:

- $h = B/15 \text{ m}$
- $h = 2 \text{ m}$

without being taken less than 1 m.

3.8.3 In case of pump rooms whose bottom plate is located above the base line by at least the minimum height required in [3.8.2] (e.g. gondola stern designs), there is no need for a double bottom construction in way of the pump-room.

3.8.4 Ballast pumps are to be provided with suitable arrangements to ensure efficient suction from double bottom tanks.

3.8.5 Notwithstanding the provisions of [3.8.2] and [3.8.3], where the flooding of the pump-room would not render the ballast or cargo pumping system inoperative, a double bottom need not be fitted.

4 Structural arrangement of asphalt carrier independent tanks and supports

4.1 Supports

4.1.1 General

Supports of independent tanks are to be designed to allow, when expected, free thermal expansion in the three directions (longitudinal, transverse and vertical) to avoid thermal stress in the tank structures and transmission of loads from the tanks to the supports.

Generally, the supports should be also designed so as to limit the transmission of loads relative to hull deflection (global and local) from the ship structure to the tanks.

The supporting of the tanks is usually achieved by means of:

- vertical supports
- antirolling keys
- antipitching keys
- antiflotation keys
- anticollision keys.

The reaction forces in way of tank supports are to be transmitted as directly as possible to the hull primary supporting members, in order to minimize stress concentration.

Where the reaction forces are not in the plane of the primary supporting members, web plates and brackets are to be provided in order to transmit these loads by means of shear stresses.

4.1.2 Information to be submitted

For every support and key, the following information is to be submitted:

- general arrangement on the ship (positioning, total surface)
- detailed fabrication and integration in the ship hull structure
- mechanical characteristics of the support pads, including compressive and shear strengths, frictional coefficients and elasticity.

4.1.3 Type approval

All the support pads (wooden, synthetic) are to be of a type approved material.

4.1.4 Openings

Openings in the structures in way of tank supports are to be reduced as much as possible and local strengthening is to be provided, as necessary.

4.2 Inspectability of the cargo area

4.2.1 Passage through cargo tanks

a) Where the Surveyor needs to pass between the flat or curved surface to be inspected and structural elements such as deck beams, stiffeners, frames, girders etc., the distance between that surface and the free edge of the structural elements is to be at least 380 mm. The distance between the surface to be inspected and the surface to which the above structural elements are fitted, e.g. deck, bulkhead or shell, is to be at least (see Fig 4):

- 450 mm in the case of a curved tank surface, or
- 600 mm in the case of a flat tank surface.

Figure 4 : Minimum passage over cargo tanks

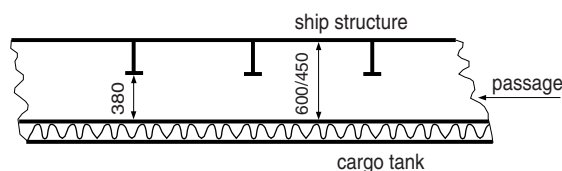

b) Where the Surveyor does not need to pass between the surface to be inspected and any part of the structure, the distance between the free edge of that structural element and the surface to be inspected is, for visibility reasons, to be at least 50 mm, or half the breadth of the structure face plate, whichever is the greater (see Fig 5).

Figure 5 : Minimum distance of structures from cargo tank to allow visual inspection

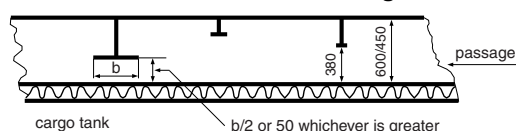

- c) Where, for inspection of a curved surface, the Surveyor needs to pass between that surface and another flat or curved surface, to which no structural elements are fitted, the distance between both surfaces is to be at least 380 mm (see Fig 6). Where the Surveyor does not need to pass between a curved surface and another surface, a distance smaller than 380 mm may be accepted, taking into account the shape of the curved surface.

Figure 6 : Minimum passage between curved surfaces

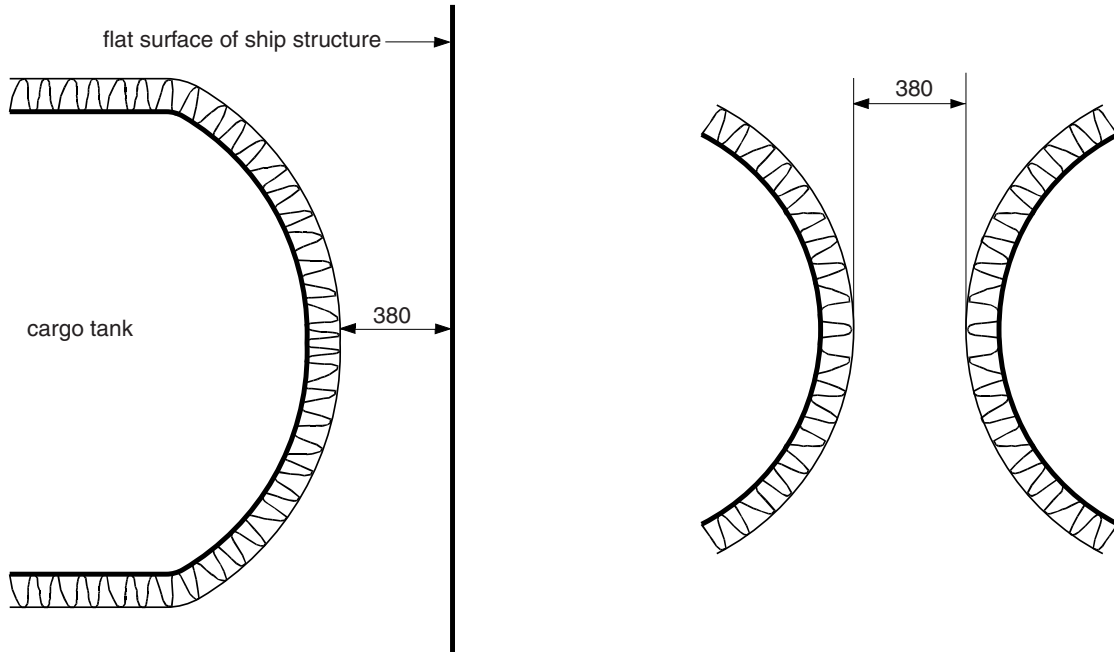

- d) Where, for inspection of an approximately flat surface, the Surveyor needs to pass between two approximately flat and approximately parallel surfaces, to which no structural elements are fitted, the distance between those surfaces is to be at least 600 mm. A clearance of at least 450 mm is to be provided where fixed access ladders are fitted (see Fig 7).

Figure 7 : Minimum passage between flat surfaces

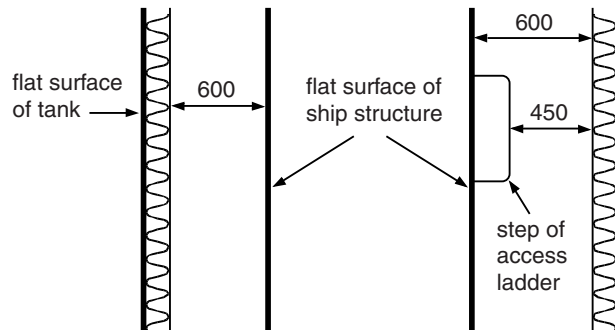

- e) The minimum distances between a cargo tank sump and the adjacent double bottom structure in way of a suction well may not be less than that defined in Fig 8. If there is no suction well, the distance between the cargo tank sump and the inner bottom may not be less than 50 mm.

Figure 8 : Minimum distance of cargo tank sump and inner bottom

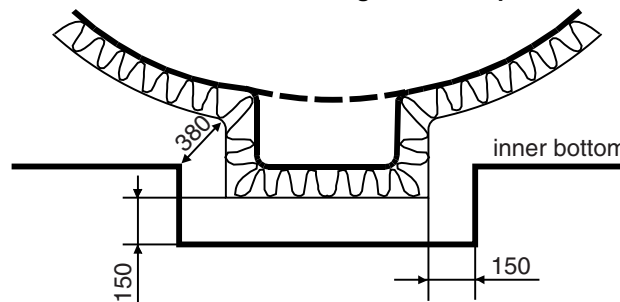

- f) The distance between a cargo tank dome and deck structures may not be less than 150 mm (see Fig 9).
 g) Where necessary for inspection, fixed or portable staging is to be installed. This staging may not impair the above specified distances.
 h) Where fixed or portable ventilation ducting is to be fitted, it may not impair the above specified distances.

Figure 9 : Minimum distance between cargo dome and deck structures

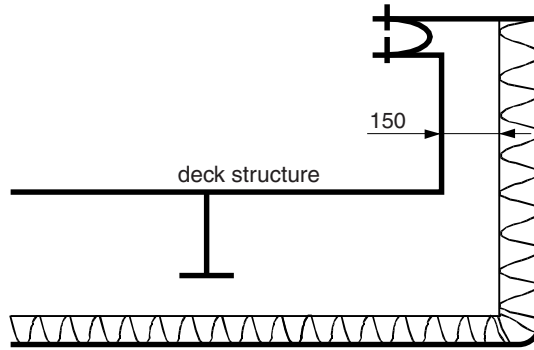

4.2.2 Passage through hatches and manholes

- a) The minimum clear opening of horizontal hatches may not be less than 600 x 600 mm, with a corner radius not exceeding 100 mm, as specified in Fig 10.
- b) The minimum clear opening of manholes may not be less than 600 x 800 mm, as specified in Fig 11.
- c) Circular access openings in cargo tanks are to have a diameter not less than 600 mm.

4.2.3 Cofferdams

Where fitted, cofferdams are to have sufficient size for easy access to all their parts. The width of the cofferdams may not be less than 600 mm.

4.2.4 Pipe tunnels

Pipe tunnels are to have enough space to permit inspection of pipes. The pipes in pipe tunnels are to be installed as high as possible from the ship's bottom.

Figure 10 : Minimum size of horizontal hatches

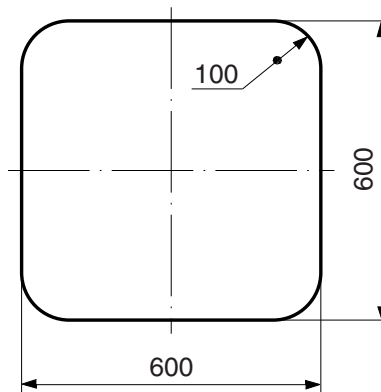
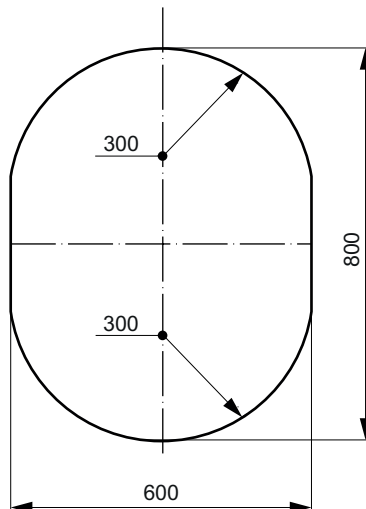

Figure 11 : Minimum size of manholes



Section 3 Hull and Stability

Symbols

L_{LL}	: Load line length, in m, defined in Pt B, Ch 1, Sec 3, [2.1.2]
R_y	: Minimum yield stress, in N/mm ² , of the material, to be taken equal to 235/k N/mm ² , unless otherwise specified
k	: Material factor for steel, defined in Pt B, Ch 4, Sec 1, [4.4]
E	: Young's modulus, in N/mm ² , to be taken equal to: <ul style="list-style-type: none"> • $E = 2,06 \cdot 10^5$ N/mm² for steels in general • $E = 1,95 \cdot 10^5$ N/mm² for stainless steels
C_{BM-LC}	: Coefficient taken as the percentage of permissible SWBM
C_{SF-LC}	: Coefficient taken as the percentage of permissible SWSF.

1 General

1.1 Documents to be submitted

1.1.1 In addition to the documentation requested in Part B, the following documents are to be submitted for ships assigned with the service notation **oil tanker ESP** or **FLS tanker**:

- Arrangement of pressure/vacuum valves in cargo tanks,
- Cargo temperatures.

2 Stability

2.1 Application

2.1.1 The requirements in [2.2.2] and [2.3] apply only to ships with the service notation **oil tanker ESP**.

2.2 Intact stability

2.2.1 General

The stability of the ship for the loading conditions in Pt B, Ch 3, App 2, [1.2.6] is to be in compliance with the requirements in Pt B, Ch 3, Sec 2. In addition, the requirements in [2.2.2] are to be complied with.

2.2.2 Liquid transfer operations

Ships with certain internal subdivision may be subjected to lolling during liquid transfer operations such as loading, unloading or ballasting. In order to prevent the effect of lolling, the design of oil tankers of 5000 t deadweight and above is to be such that the following criteria are complied with:

- a) *The intact stability criteria reported in b) is to be complied with for the worst possible condition of loading and ballasting as defined in c), consistent with good operational practice, including the intermediate stages of liquid transfer operations. Under all conditions the ballast tanks are to be assumed slack.*
- b) *The initial metacentric height GMO , in m, corrected for free surface measured at 0° heel, is to be not less than 0,15. For the purpose of calculating GMO , liquid surface corrections are to be based on the appropriate upright free surface inertia moment.*
- c) *The vessel is to be loaded with:*
 - *all cargo tanks filled to a level corresponding to the maximum combined total of vertical moment of volume plus free surface inertia moment at 0° heel, for each individual tank*
 - *cargo density corresponding to the available cargo deadweight at the displacement at which transverse KM reaches a minimum value*
 - *full departure consumable*
 - *1% of the total water ballast capacity. The maximum free surface moment is to be assumed in all ballast tanks.*

2.3 Damage stability for ships where the additional class notation SDS is required

2.3.1 General

Every oil tanker is to comply with the subdivision and damage stability criteria as specified in [2.3.8], after the assumed side or bottom damage as specified in [2.3.2], for the standard of damage described in [2.3.3], and for any operating draught reflecting actual partial or full load conditions consistent with trim and strength of the ship as well as specific gravities of the cargo.

The actual partial or full load conditions to be considered are those specified in Pt B, Ch 3, App 2, [1.2.6], but ballast conditions where the oil tanker is not carrying oil in cargo tanks, excluding any oil residues, are not to be considered.

2.3.2 Damage dimensions

The assumed extent of damage is to be as defined in Tab 1.

The transverse extent of damage is measured inboard the ship side at right angles to the centreline at the level of the summer load line.

For the purpose of determining the extent of assumed damage, suction wells may be neglected, provided such wells are not excessive in areas and extend below the tank for a minimum distance and in no case more than half the height of the double bottom.

The vertical extent of damage is measured from the moulded line of the bottom shell plating at centreline.

If any damage of a lesser extent than the maximum extent of damage specified in Tab 1 would result in a more severe condition, such damage is to be considered.

Table 1 : Extent of damage

Damage		Longitudinal extent	Transverse extent	Vertical extent
Side		$l_c = 1/3 L_{LL}^{2/3}$ or 14,5 m (1)	$t_c = B/5$ or 11,5 m (1)	$v_c =$ without limit
Bottom	For 0,3 L_{LL} from the forward perpendicular	$l_s = 1/3 L_{LL}^{2/3}$ or 14,5 m (1)	$t_s = B/6$ or 10 m (1)	$v_s = B/15$ or 6 m (1)
	any other part	$l_s = 1/3 L_{LL}^{2/3}$ or 5 m (1)	$t_s = B/6$ or 5 m (1)	$v_s = B/15$ or 6 m (1)
(1) Whichever is the lesser				

2.3.3 Standard of damage

The damage in [2.3.2] is to be applied to all conceivable locations along the length of the ship, according to Tab 2.

Table 2 : Standard of damage

Ship's length, in m	Damage anywhere in ship's length	Damage between transverse bulkheads	Machinery space flooded
$L_{LL} \leq 100$	No	Yes (1) (2)	No
$100 < L_{LL} \leq 150$	No	Yes (1)	No
$150 < L_{LL} \leq 225$	Yes	No	Yes, alone
$L_{LL} > 225$	Yes	No	Yes
(1) Machinery space not flooded.			
(2) Exemptions from the requirements of [2.3.8] may be accepted by the Society on a case-by-case basis.			

2.3.4 Calculation method

The metacentric heights (GM), the stability levers (GZ) and the centre of gravity positions (KG) for judging the final survival conditions are to be calculated by the constant displacement method (lost buoyancy).

2.3.5 Flooding assumptions

The requirements of [2.3.8] are to be confirmed by calculations which take into consideration the design characteristics of the ship, the arrangements, configuration and contents of the damaged compartments and the distribution, specific gravities and free surface effect of liquids.

Where the damage involving transverse bulkheads is envisaged as specified in [2.3.3], transverse watertight bulkheads are to be spaced at least at a distance equal to the longitudinal extent of assumed damage specified in [2.3.2] in order to be considered effective. Where transverse bulkheads are spaced at a lesser distance, one or more of these bulkheads within such extent of damage is to be assumed as non-existent for the purpose of determining flooded compartments.

Where the damage between adjacent transverse watertight bulkheads is envisaged as specified in [2.3.3], no main transverse bulkhead bounding side tanks or double bottom tanks is to be assumed damaged, unless:

- the spacing of the adjacent bulkheads is less than the longitudinal extent of assumed damage specified in [2.3.2] or,
- there is a step or a recess in a transverse bulkhead of more than 3,05 metres in length, located within the extent of penetration of assumed damage. The step formed by the after peak bulkhead and after peak tank top is not to be regarded as a step.

2.3.6 Progressive flooding

If pipes, ducts or tunnels are situated within the assumed extent of damage penetration as defined in [2.3.2], arrangements are to be made so that progressive flooding cannot thereby extend to compartments other than those assumed to be floodable in the calculation for each case of damage.

2.3.7 Permeabilities

The specific gravity of cargoes carried, as well as any outflow of liquid from damaged compartments, are to be taken into account for any empty or partially filled tank.

The permeability of compartments assumed to be damaged are to be as indicated in Tab 3.

Table 3 : Permeability

Compartments	Permeability
Appropriate for stores	0,60
Occupied by accommodation	0,95
Occupied by machinery	0,85
Void compartments	0,95
Intended for consumable liquids	0 to 0,95 (1)
Intended for other liquids	0 to 0,95 (1)
(1) The permeability of partially filled compartments is to be consistent with the amount of liquid carried in the compartment.	

2.3.8 Survival requirements

Oil tankers are to be regarded as complying with the damage stability criteria if the requirements of [2.3.9] and [2.3.10] are met.

2.3.9 Final stage of flooding

- a) The final waterline, taking into account sinkage, heel and trim, is to be below the lower edge of any opening through which progressive flooding may take place. The progressive flooding is to be considered in accordance with Pt B, Ch 3, Sec 3, [3.3].
- b) The angle of heel due to unsymmetrical flooding may not exceed 25°, except that this angle may be increased up to 30° if no deck edge immersion occurs.
- c) The stability is to be investigated and may be regarded as sufficient if the righting lever curve has at least a range of 20° beyond the position of equilibrium in association with a maximum residual righting lever, in m, of at least 0,1 within the 20° range; the area, in m-rad, under the curve within this range is to be not less than 0,0175.

2.3.10 Intermediate stage of flooding

The Society is to be satisfied that the stability is sufficient during the intermediate stages of flooding. To this end the Society applies the same criteria relevant to the final stage of flooding also during the intermediate stages of flooding.

2.3.11 Bottom raking damage

This requirement applies to oil tankers of 20000 t deadweight and above.

The damage assumptions relative to the bottom damage prescribed in [2.3.2] are to be supplemented by the assumed bottom raking damage of Tab 4.

The requirements of [2.3.8] are to be complied with for the assumed bottom raking damage.

Table 4 : Bottom damage extent

Deadweight	Longitudinal extent	Transverse extent	Vertical extent
< 75000 t	0,4 L _{LL} (1)	B/3	(2)
≥ 75000 t	0,6 L _{LL} (1)	B/3	(2)
(1) Measured from the forward perpendicular.			
(2) Breach of the outer hull.			

2.3.12 Equalisation arrangements

Equalisation arrangements requiring mechanical aids such as valves or cross levelling pipes, if fitted, may not be considered for the purpose of reducing an angle of heel or attaining the minimum range of residual stability to meet the requirements of [2.3.9] and sufficient residual stability is to be maintained during all stages where equalisation is used. Compartments which are linked by ducts of a large cross-sectional area may be considered to be common.

2.3.13 Information to the Master

The Master of every oil tanker is to be supplied in an approved form with:

- information relative to loading and distribution of cargo necessary to ensure compliance with the requirements relative to stability, and
- data on the ability of the ship to comply with damage stability criteria as determined in [2.3.8] including the effect of relaxation that may have been allowed as specified in Tab 2.

3 Structure design principles

3.1 Framing arrangement

3.1.1 In general, within the cargo tank region of ships of more than 90 m in length, the bottom, the inner bottom and the deck are to be longitudinally framed.

Different framing arrangements are to be considered by the Society on a case-by-case basis, provided that they are supported by direct calculations.

3.2 Bulkhead structural arrangement

3.2.1 General

Transverse bulkheads may be either plane or corrugated.

3.2.2 Corrugated bulkheads

For ships of less than 120 m in length, vertically corrugated transverse or longitudinal bulkheads may be connected to the double bottom and deck plating.

For ships equal to or greater than 120 m in length, lower and upper stools are to be fitted.

4 Design loads

4.1 Loading conditions for longitudinal strength assessment

4.1.1 Seagoing conditions

In addition to the loading conditions specified in Pt B, Ch 5, Sec 8, the following seagoing loading conditions are to be included, as a minimum, in the loading manual:

- a) Heavy ballast condition where the ballast tanks may be full, partially full or empty. Where ballast tanks are partially full, the conditions in item b of Pt B, Ch 5, Sec 8, [3.1.1] are to be complied with. The fore peak water ballast tank is to be full, if fitted. If upper and lower fore peak tanks are fitted, the lower is required to be full and the upper tank may be full, partially full or empty. All the cargo tanks are to be empty including cargo tanks suitable for the carriage of water ballast at sea. The draught at the forward perpendicular is not to be less than that for the normal ballast condition. The propeller is to be fully immersed. The trim is to be by the stern and is not to exceed $0,015 L_{LL}$
- b) Mid-voyage conditions relating to tank cleaning or other operations where these differ significantly from the ballast conditions
- c) Any specified non-uniform distribution of loading
- d) Conditions with high density cargo including the maximum design cargo density, when applicable
- e) Design ballast condition in which all segregated ballast tanks in the cargo tank region are full and all other tanks are empty including fuel oil and fresh water tanks. This design condition is for assessment of hull strength and is not intended for ship operation.

4.1.2 Additional loading conditions

In addition to the loading conditions specified in Pt B, Ch 5, Sec 8, the following additional loading conditions are to be included in the loading manual if the ship is specifically approved and intended to be operated in such conditions:

- a) Seagoing ballast conditions including water ballast carried in one or more cargo tanks which are intended for use in emergency situations as allowed by MARPOL Reg. 18
- b) Seagoing loading conditions where the net static upward load on the double bottom exceeds that given with the combination of an empty cargo tank and a mean ship's draught of $0,9 T_{SC}$
- c) Seagoing loading conditions with cargo tanks less than 25% full with the combination of mean ship's draught greater than $0,9 T_{SC}$
- d) Seagoing loading conditions where the net static downward load on the double bottom exceeds that given with the combination of a full cargo tank at a cargo density of $1,025 t/m^3$ or greater and a mean ship's draught of $0,6 T_{SC}$
- e) For ships arranged with cross ties in the centre cargo tank, seagoing loading conditions showing a non-symmetric loading pattern where the difference in filling level between corresponding port and starboard wing cargo tanks exceeds 25% of the filling height in the wing cargo tank.

4.2 Local loads

4.2.1 Bottom impact pressure

For oil tankers of 20000 t deadweight and above and product carriers of 30000 t deadweight and above, the draught T_{LC} corresponding to loading conditions using the segregated ballast tanks only are to be considered in the calculation of the bottom impact pressure according to Pt B, Ch 5, Sec 5, [4.2.1] in addition to other loading conditions.

4.2.2 Cargo mass density

In the absence of more precise values, a cargo mass density of $0,9 \text{ t/m}^3$ is to be considered for calculating the internal pressures and forces in cargo tanks according to Pt B, Ch 5, Sec 6.

4.2.3 Partial filling

The carriage of cargoes with a mass density above the one considered for the design of the cargo tanks may be allowed with partly filled tanks under the conditions stated in Pt B, Ch 5, Sec 6, [2]. The classification certificate or a memorandum provided for in Pt A, Ch 1, Sec 2, [4.4] is to mention these conditions of carriage.

4.2.4 Overpressure due to cargo filling operations

For ships having the additional service feature **asphalt carrier**, the overpressure which may occur under loading/unloading operations are to be considered, if any. In such a case, the diagram of the pressures in loading/unloading conditions is to be given by the Designer.

4.3 Load combinations for direct strength analysis

4.3.1 The loading conditions to be considered for the direct strength analysis are defined in [4.3.1] to [4.3.5].

4.3.2 Ships with structure symmetrical about centreline

For ships with structure symmetrical about the centreline, the loading patterns mirrored about centreline of another pattern may be omitted provided the results (yield and buckling) are mirrored.

4.3.3 Tankers with two oil-tight longitudinal bulkheads except with a cross tie arrangement in the wing cargo tanks

Any loading patterns with unequal filling levels in transversely paired wing cargo tanks that would result in a more onerous stress response are to be examined. The actual loading pattern, draught, GM and k_r from the loading manual are to be used in the FE analysis. Where the GM and k_r are not given in the ship's loading manual, they are to be determined in accordance with Pt B, Ch 5, Sec 3.

If such loading pattern is considered, an operational restriction describing that the difference in filling level between corresponding port and starboard wing cargo tanks is not to exceed 25% of the filling height in the wing cargo tank, is to be added in the loading manual.

4.3.4 Tankers with two oil-tight longitudinal bulkheads

- Seagoing loading pattern with all cargo tanks abreast empty are to be analysed with a ship draught of $0,65 T_{SC}$ and $0,7 T_{SC}$ respectively. If conditions in the ship loading manual specify greater draughts, then the maximum specified draught in the ship's loading manual for the loading pattern is to be used.
- Seagoing and harbour loading patterns with all cargo tanks abreast fully loaded are to be analysed with a ship draught of $0,65 T_{SC}$ and $0,6 T_{SC}$ respectively. If conditions in the ship loading manual specify lesser draughts, then the minimum specified draught in the ship's loading manual for the loading pattern is to be used.

4.3.5 For loading patterns with cargo tank(s) empty, a minimum ship draught of $0,9 T_{SC}$ is to be used in the analysis. If conditions in the ship loading manual specify greater draughts, then the maximum specified draught for the actual condition is to be used.

4.3.6 Ballast conditions

Any ballast condition specified in the ship loading manual with ballast water filled in one or more cargo tanks is to be examined. The actual loading pattern, draught, GM and k_r from the loading manual are to be used in the direct strength analysis. Where the GM and k_r are not given in the ship's loading manual, they are to be determined in accordance with Pt B, Ch 5, Sec 3.

5 Hull scantlings

5.1 Strength check with respect to stresses due to the temperature gradient

5.1.1 General

Direct calculations of stresses induced in the hull structures by the temperature gradient are to be performed:

- for ships intended to carry cargoes at temperatures exceeding 90°C
- and when part of the hull structures temperature exceeds 90°C

In these calculations, the water temperature is to be assumed equal to 0°C.

The calculations are to be submitted to the Society for review.

5.1.2 Material

For steels used at a temperature θ between 90°C and 300°C, and unless other information is specified, their minimum yield stress R_{eH} and Young's modulus E are to be taken as specified in Pt B, Ch 4, Sec 1, [2.1.1].

The material factor is to be adjusted accordingly.

5.1.3 Thermal stress for integral tanks

The stresses induced in the hull structures by the temperature gradient are to comply with the checking criteria in Pt B, Ch 8, App 1, [5.2.3].

5.1.4 Thermal stress for independent tanks

Where a thermal elongation is made possible due to the design of the tank supports, the thermal stress may be neglected provided the cargo temperature distribution is rather uniform.

In addition, precautions are to be taken, upon loading of any hot cargo, by pre-heating the tanks in order to minimize the temperature gradients within the cargo hold.

5.2 Hull girder stress for independent tanks structures

5.2.1 In general, the hull girder stresses may be taken equal to zero.

Where the length of the tank under consideration exceeds both 0,15L and 3,5 times its breadth, the stresses in the tank due to the hull girder loads are to be taken into account. These stresses are, in general, to be obtained by means of direct calculations based on a finite element model of the hull and the tank with its supporting and keying system.

6 Scantlings of independent tanks structures

6.1 Plating

6.1.1 In general, the net plating thickness of independent tanks is to be not less than the values obtained from the applicable formulae given in Pt B, Ch 7, Sec 4, where the lateral pressures are to be calculated according to Part B, Chapter 5.

6.2 Ordinary stiffeners

6.2.1 In general, the net scantlings of the ordinary stiffeners of independent tanks are to be not less than the values obtained from the applicable formulae given in Pt B, Ch 7, Sec 5, where the lateral pressures are to be calculated according to Part B, Chapter 5.

6.3 Primary supporting members

6.3.1 The net scantlings of the primary supporting members are to be obtained by means of direct calculations according to [8].

7 Supports of independent tanks

7.1 General

7.1.1 The reaction forces in way of tank supports are to be obtained from the structural analysis of the tank, taking into account the relative hull bottom stiffness and considering the loads and accelerations specified in Part B, Chapter 5, in addition to the static steel weight of the tank.

If the supports are not able to react in tension, the final distribution of the reaction forces at the supports is not to show any tensile forces.

7.2 Vertical supports

7.2.1 General

When used together with hot cargoes, the material of a vertical support is to present the following qualities:

- very low thermal conductivity
- good mechanical performances at the highest temperatures:
 - compressive strength, to reduce the supporting area
 - elasticity, to avoid cracks (no brittleness) and to spread the load
 - shear strength, to support horizontal forces due to thermal extension of the tank
 - average frictional coefficient, to reduce loads on keys while avoiding excessive shear stresses in the support.

7.2.2 Scantling

The tank structure and the ship structure are to be reinforced in way of the supports so as to withstand the combined reactions defined in [7.1] (compression induced by the vertical acceleration and shear induced by the longitudinal or transverse acceleration) and corresponding moments.

For the purpose of this assessment, the frictional coefficient of the vertical supports is to be taken equal to 0,3, unless duly justified.

7.3 Antirolling keys

7.3.1 General

Antirolling keys fitted at top of the tank are generally necessary for narrow and high tanks which may capsize at rolling, as well as for filling levels lower than 90%. Otherwise, bottom keys may be sufficient.

A risk of capsizing of the tank is to be considered when:

$$a_y y_G \geq (g - a_z) z_G$$

where:

g : Gravity acceleration, in m/s^2

a_y, a_z : Transverse and vertical accelerations for the BR dynamic load cases, as defined in Pt B, Ch 5, Sec 3, [3.2]

y_G, z_G : Transverse and vertical distances between the vertical support a side and the centre of gravity of the tank.

The frictional load taken by the vertical supports may be deduced from the lateral load, provided the minimum value of the frictional coefficients between tank and vertical supports are duly justified by the Designer. In general, for the purpose of this assessment, the frictional coefficient of the vertical supports is to be taken equal to 0,1.

7.3.2 Load cases

Antirolling keys are to be checked under transverse and vertical accelerations for the inclined ship condition, considering the maximum full tank weight.

7.4 Antipitching keys

7.4.1 Antipitching keys are fitted to prevent the tank from moving longitudinally.

They may also be used for anticollision purpose (see [7.5]).

7.4.2 Load cases

Antipitching keys are to be checked under longitudinal and vertical accelerations for the upright ship condition, considering the maximum full tank weight.

7.5 Anticollision keys

7.5.1 General

Anticollision keys may be combined with antipitching keys (see [7.4]).

7.5.2 Load cases

Anticollision keys are to withstand a collision force acting on the tank corresponding to half the tank and cargo weight in the forward direction and one quarter of the tank and cargo weight in the aftward direction, considering the maximum full tank weight.

7.6 Antiflotation keys

7.6.1 General

When antiflotation keys are fitted at the top of the tanks, they are positioned on both sides, in order to minimize the bending moment induced on deck transverses.

7.6.2 Load cases

Antiflotation keys are to withstand an upward force caused by an empty tank floating in a hold flooded up to the deepest equilibrium waterline after damage for the loading conditions among which the tank under consideration is empty.

7.7 Yielding criteria

7.7.1 It is to be checked that the Von Mises stress σ_{vm} in the supports and keys, in N/mm^2 , is in compliance with the requirements in [8.3.3].

8 Independent tanks direct strength analysis

8.1 General

8.1.1 Yielding and buckling check of primary supporting members is to be performed within the cargo area by means of FE analysis.

Local fine mesh models are to be performed for the analysis of highly stressed areas, supports and keys, as required in [8.3.1].

8.2 Three cargo holds model

8.2.1 Model extension

As a rule, the cargo tank to be assessed is to be modelled with its two adjacent holds and tanks (fore and aft). The model is to include the hold, the cargo tank and the supports.

The assessment of a tank may be waived when the tank is similar enough to an already checked cargo tank.

8.2.2 Hold modelling

The following items of the hold are to be modelled:

- outer shell, inner shell, deck, bottom, inner bottom and transverse bulkheads plating
- double bottom longitudinal girders
- double side horizontal girders
- deck longitudinal girders
- transverse web frames
- primary supporting members of transverse bulkheads.

8.2.3 Cargo tank modelling

The following items of the cargo tank are to be modelled:

- shell plating
- bulkheads plating, including wash bulkheads, if any
- bottom plating
- top plating
- transverse web frames
- horizontal stringers
- girders.

In addition, the static steel weight of the tank is to be considered.

8.2.4 Supports and keys modelling

The cargo tanks are linked to the hold by the following supports and keys, acting in one direction:

- vertical supports (Z direction)
- antipitching keys (X direction), used also as anticollision keys
- antirolling keys (Y direction)
- antiflotation keys (Z direction).

They can be modelled by either linear elements (bar, flexible mounts, springs), or non-linear elements (gap elements).

When linear elements are used to model keys and supports not allowing tension loads, they are to be deleted when in tension.

Stiffness of these linear and/or non-linear elements is to be representative of the actual stiffness of the supports and keys.

The stiffness of the pad located between the lower and upper parts of the support may be calculated as follows: $K = E S / h$ where:

- K : Stiffness of the pad, in N/mm
E : Young modulus of the pad, in MPa
S : Sectional area of the pad, in mm²
h : Height of the pad, in mm.

The stiffness of the gap or spring element is to be taken as: $K_{\text{element}} = K / N_{\text{elements}}$

with:

N_{elements} : Number of elements used in the pad modelling.

8.2.5 Size of the elements

The mesh size are to be equal to the spacing of the longitudinal ordinary stiffeners. Each of these longitudinal stiffeners is to be modelled. The aspect ratio of the elements is to be as close to 1,0 as possible.

8.2.6 Boundary conditions

The requirements of Pt B, Ch 8, App 1, [2.5] are to be applied.

8.3 Local fine mesh models

8.3.1 Areas to be modelled

The following local fine meshes are, at least, to be carried out for:

- each type of support (vertical support, upper part or lower part)
- high stressed areas which do not meet the screening criterion defined in Pt B, Ch 8, App 2, [1.2.3], where λ_{sc} and λ_{scperm} are to be taken equal to respectively λ_y and $0,89 \lambda_{yperm}$

Other fine mesh models may be required, at the request of the Society.

8.3.2 Size of the elements

For fine mesh models of the various supports and keys, the size of the elements is not to be taken greater than 50 x 50 mm.

In case of finer mesh, the equivalent stress is to be obtained by averaging over an equivalent area of 50 x 50 mm.

8.3.3 Yielding criteria

It is to be checked that the Von Mises stress σ_{vm} in the supports and keys, in N/mm², is in compliance with the requirements in Pt B, Ch 8, App 2, [4.1.3].

9 Other structures

9.1 Machinery space

9.1.1 Extension of the hull structures within the machinery space

Longitudinal bulkheads carried through cofferdams are to continue within the machinery space and are to be used preferably as longitudinal bulkheads for liquid cargo tanks. In any case, such extension is to be compatible with the shape of the structures of the double bottom, deck and platforms of the machinery space.

9.2 Opening arrangement

9.2.1 Tanks covers

Covers fitted on all cargo tank openings are to be of sturdy construction, and to ensure tightness for hydrocarbon and water.

Aluminium is not permitted for the construction of tank covers. The use of reinforced fibreglass covers is to be specially examined by the Society.

For the protection of cargo tanks carrying crude oil and petroleum products having a flash point not exceeding 60°C, materials readily rendered ineffective by heat are not to be used for tank opening covers so as to prevent the spread of fire to the cargo.

10 Hull outfitting

10.1 Equipment

10.1.1 Emergency towing arrangements

The specific requirements in Pt B, Ch 12, Sec 4, [3] for ships with the service notation **oil tanker ESP** or **FLS tanker** and of 20000 t deadweight and above are to be complied with.

11 Protection of hull metallic structures

11.1 Protection by aluminium coatings

11.1.1 The use of aluminium coatings containing greater than 10% aluminium by weight in the dry film is prohibited in the cargo tanks, cargo tank deck area, pump rooms, cofferdams or any other area where cargo vapour may accumulate.

11.2 Material and coatings of tanks

11.2.1 The resistance of materials and coatings and their compatibility with intended cargoes are the responsibility of the builder or owner. All supporting documents are, however, to be given to the Society to allow the issue of the list of cargoes annexed to the classification certificate.

Copy of the charts of coating and/or material resistance issued by the manufacturers is to be kept on board. These documents are to indicate the possible restrictions relative to their use.

12 Cathodic protection of tanks

12.1 General

12.1.1 Internal structures in spaces intended to carry liquids may be provided with cathodic protection.

Cathodic protection may be fitted in addition to the required corrosion protective coating, if any.

12.1.2 Details concerning the type of anodes used and their location and attachment to the structure are to be submitted to the Society for approval.

12.2 Anodes

12.2.1 Magnesium or magnesium alloy anodes are not permitted in oil cargo tanks and tanks adjacent to cargo tanks.

12.2.2 Aluminium anodes are only permitted in cargo tanks and tanks adjacent to cargo tanks in locations where the potential energy does not exceed 28 kg m. The height of the anode is to be measured from the bottom of the tank to the centre of the anode, and its weight is to be taken as the weight of the anode as fitted, including the fitting devices and inserts.

However, where aluminium anodes are located on horizontal surfaces such as bulkhead girders and stringers not less than 1 m wide and fitted with an upstanding flange or face flat projecting not less than 75 mm above the horizontal surface, the height of the anode may be measured from this surface.

Aluminium anodes are not to be located under tank hatches or washing holes, unless protected by the adjacent structure.

12.2.3 There is no restriction on the positioning of zinc anodes.

12.2.4 Anodes are to have steel cores and are to be declared by the Manufacturer as being sufficiently rigid to avoid resonance in the anode support and designed so that they retain the anode even when it is wasted.

12.2.5 The steel inserts are to be attached to the structure by means of a continuous weld. Alternatively, they may be attached to separate supports by bolting, provided a minimum of two bolts with lock nuts are used. However, other mechanical means of clamping may be accepted.

12.2.6 The supports at each end of an anode may not be attached to separate items which are likely to move independently.

12.2.7 Where anode inserts or supports are welded to the structure, they are to be arranged by the Shipyard so that the welds are clear of stress peaks.

12.2.8 As a general rule, the requirements [12.2.1] to [12.2.7] apply also to spaces or compartments adjacent to cargo or slop tanks.

12.3 Impressed current systems

12.3.1 Impressed current cathodic protections are not accepted in cargo or slop tanks, unless specially authorized by the Society.

13 Construction and testing

13.1 Welding and weld connections

13.1.1 It is recommended to use continuous fillet welding to connect primary supporting member web to its associated shell plating. The leg length of such a welding is not to be less than the value specified in Pt B, Ch 13, Sec 3, Tab 3.

Discontinuous welds are not allowed for primary members perpendicular to ordinary stiffeners.

For longitudinals, intermittent scallop welding can be accepted as for primary members parallel to longitudinals, especially in small ships.

Intermittent scallop welding can be accepted for some members.

Where scallop fillet is used, the scallops are to be avoided:

- in way of the connecting brackets and at least more than 200 mm beyond the beginning of the bracket
- more than 200 mm about on either side of the connection of the ordinary stiffeners to the primary stiffeners
- on bottom transverses, shell stringers and longitudinal bulkhead stringers
- on the lower half of side shell and longitudinal bulkhead transverses, and on the web frames of transverse bulkheads.

13.1.2 The weld factors for some hull structural connections are specified in Tab 5. These weld factors are to be used, in lieu of the corresponding factors specified in Pt B, Ch 13, Sec 3, Tab 1, to calculate the leg length of fillet weld T connections according to Pt B, Ch 13, Sec 3, [3.2.6]. For the connections of Tab 5, continuous fillet welding is to be adopted.

Table 5 : Weld factor w_F

Hull area	Connection		Weld factor w_F
	of	to	
Double bottom in way of cargo tanks	girders	bottom and inner bottom plating	0,48
		floors (interrupted girders)	
	floors	bottom and inner bottom plating	
		girders (interrupted floors)	
Bulkheads (1)	ordinary stiffeners	bulkhead plating	

(1) Not required to be applied to ships with the additional service feature **flash point > 60°C**.

13.1.3 For ships of more than 250 m in length, leg lengths of fillet welds for transverse web frames and horizontal stringers on transverse bulkheads are to be reinforced as shown in Fig 1 and Fig 2.

The length, in m, of reinforcement is not to be less than the greater of the following values:

- $l = 2s$
- $l = 1,2$

where s is the spacing, in m, of the ordinary stiffeners.

13.2 Special structural details

13.2.1 The specific requirements in Pt B, Ch 13, Sec 5, [2.3] for ships with the service notation **oil tanker ESP, FLS tanker or asphalt carrier** are to be complied with.

Figure 1 : Reinforcement of throat thickness for ships greater than 250 m

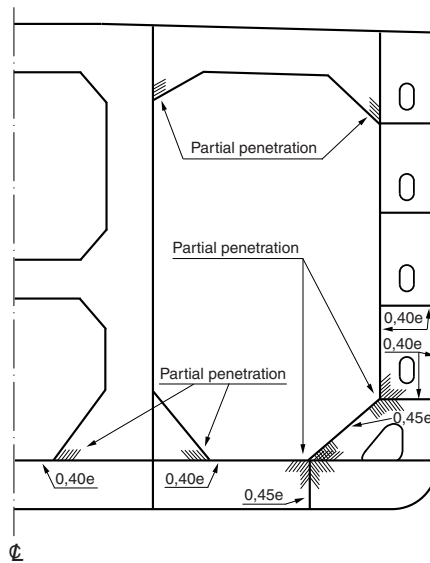
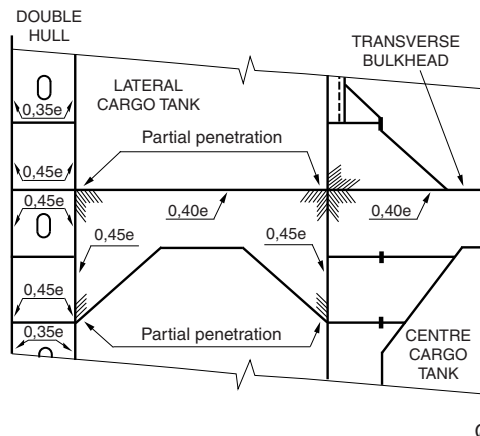

Figure 2 : Reinforcement of throat thickness for ships greater than 250 m



Section 4 Machinery and Cargo Systems

1 General

1.1 Application

1.1.1 Relaxations applying to certain service notations

Articles [2] to [7] provide requirements that apply to ships having the service notation **oil tanker** and, where indicated in the relevant notes, the relaxations which may be accepted for ships of less than 500 gross tonnage and for ships having the following service notations:

- **oil tanker, flash point > 60°C**
- **oil tanker, asphalt carrier**
- **FLS tanker**
- **FLS tanker, flash point > 60°C.**

Such relaxations are summarised in Tab 1.

1.1.2 Additional requirements

Additional requirements are provided in:

- [8] for ships having the service notation **oil tanker, asphalt carrier**
- [9] for ships intended to carry substances of pollution category Z.

1.2 Documents to be submitted

1.2.1 The documents listed in Tab 2 are to be submitted for approval.

1.3 Abbreviations

1.3.1 The following abbreviations are used in this Section.

FP : Flash point, in °C.

Table 1 : Possible relaxations according to service notation

Subject	Reference to the Rules	Service notation or other feature of the ship to which relaxations apply	Relaxations
Driven pumps for bilge, ballast, etc.	[2.1.4]	< 500 GT	equivalent arrangements accepted
Drainage of cofferdams	[2.2.5]	< 500 GT	hand pumps permitted
Ballast pumps	[2.3.2]	<ul style="list-style-type: none"> • oil tanker, flash point > 60°C • oil tanker, asphalt carrier • FLS tanker, flash point > 60°C 	Shaft misalignment compensation, gastightness of the shaft gland and temperature sensors are not required
Air and sounding pipes of spaces other than cargo tanks	[2.4]	<ul style="list-style-type: none"> • oil tanker, flash point > 60°C • oil tanker, asphalt carrier • FLS tanker, flash point > 60°C 	NA (1)
Cargo pumps	[3.2.3] [3.2.4] [3.2.5]	<ul style="list-style-type: none"> • oil tanker, flash point > 60°C • oil tanker, asphalt carrier • FLS tanker, flash point > 60°C 	Shaft misalignment compensation, gas-tightness of the shaft gland and temperature sensors are not required
Generation of static electricity	[3.4.4]	<ul style="list-style-type: none"> • oil tanker, flash point > 60°C • oil tanker, asphalt carrier • FLS tanker, flash point > 60°C 	NA (1)
Bow or stern cargo loading and unloading arrangement	[3.4.5]	<ul style="list-style-type: none"> • oil tanker, flash point > 60°C • oil tanker, asphalt carrier • FLS tanker, flash point > 60°C 	NA (1)

(1) NA means that the requirements referred to in the second column of the table are not applicable.

Subject	Reference to the Rules	Service notation or other feature of the ship to which relaxations apply	Relaxations
Cargo tank venting	[4.2]	<ul style="list-style-type: none"> oil tanker, flash point > 60°C oil tanker, asphalt carrier FLS tanker, flash point > 60°C 	See Tab 5
Cargo tank purging/gas-freeing	[4.3]	<ul style="list-style-type: none"> oil tanker, flash point > 60°C oil tanker, asphalt carrier FLS tanker, flash point > 60°C 	NA (1)
Tank level gauging	[4.4]	<ul style="list-style-type: none"> oil tanker, flash point > 60°C oil tanker, asphalt carrier FLS tanker, flash point > 60°C 	See Tab 5
Tank washing	[4.6]	<ul style="list-style-type: none"> FLS tanker, FLS tanker, flash point > 60°C 	NA (1)
Retention of oil on board	[5.2]	<ul style="list-style-type: none"> oil tanker, asphalt carrier FLS tanker, FLS tanker, flash point > 60°C 	NA (1)
Oil discharge monitoring and control system	[5.3]	<ul style="list-style-type: none"> oil tanker, less than 150 gross tonnage oil tanker, flash point > 60°C, and less than 150 gross tonnage oil tanker, asphalt carrier FLS tanker FLS tanker, flash point > 60°C 	NA (1)
Oil contaminated water discharge arrangements	[5.4]	<ul style="list-style-type: none"> FLS tanker FLS tanker, flash point > 60°C 	NA (1)
Survey of pollution prevention equipment	[6.3.2]	<ul style="list-style-type: none"> FLS tanker FLS tanker, flash point > 60°C 	NA (1)

(1) NA means that the requirements referred to in the second column of the table are not applicable.

Table 2 : Documents to be submitted

No.	Description of the document (1)
1	General layout of cargo pump room with details of: <ul style="list-style-type: none"> bulkhead penetrations gas detection system other alarms and safety arrangements
2	Diagram of cargo piping system
3	Diagram of the cargo tank venting system with: <ul style="list-style-type: none"> indication of the outlet position details of the pressure/vacuum valves and flame arrestors details of the draining arrangements, if any
4	Diagram of the cargo tank level gauging system with overfill safety arrangements
5	Diagram of the cargo tank cleaning system
6	Diagram of the bilge and ballast systems serving the spaces located in the cargo area
7	Diagram of the cargo heating systems
8	Diagram of inert gas system with details of the inert gas plant
9	Diagram of gas measurement system for double hull and double bottom spaces

(1) Diagrams are also to include, where applicable, the (local and remote) control and monitoring systems and automation systems

2 Piping systems other than cargo piping system

2.1 General

2.1.1 Materials

- Materials are to comply with the provisions of Pt C, Ch 1, Sec 10.
- Spheroidal graphite cast iron may be accepted for bilge and ballast piping within double bottom or cargo tanks.
- Grey cast iron may be accepted for ballast lines within cargo tanks, except for ballast lines to forward tanks through cargo tanks.

2.1.2 Independence of piping systems

- Unless otherwise specified in this Chapter, bilge, ballast and scupper systems serving spaces located within the cargo area:
 - are to be independent from any piping system serving spaces located outside the cargo area
 - are not to lead outside the cargo area.
- Fuel oil systems are to:
 - be independent from the cargo piping system
 - have no connections with pipelines serving cargo or slop tanks.

2.1.3 Passage through cargo tanks and slop tanks

- Unless otherwise specified, bilge, ballast and fuel oil systems serving spaces located outside the cargo area are not to pass through cargo tanks or slop tanks. They may pass through ballast tanks or void spaces located within the cargo area.
- Where expressly permitted, ballast pipes passing through cargo tanks are to fulfil the following provisions:
 - they are to have welded or heavy flanged joints the number of which is kept to a minimum
 - they are to be of extra-reinforced wall thickness as per Tab 3
 - they are to be adequately supported and protected against mechanical damage.
- Where required by Ch 7, Sec 2, [3.4.1], lines of piping which run through cargo tanks are to be fitted with closing devices.

Table 3 : Minimum wall thickness for carbon steel pipes

Nominal diameter (mm)	Minimum wall thickness (mm)
50	6,3
100	8,6
125	9,5
150	11,0
200 and above	12,5

2.1.4 Pumps forward of cargo tank area

One or more driven pumps are to be fitted, in a suitable space forward of cargo tanks, for bilge, ballast and, where relevant, fuel oil services.

Note 1: On ships of less than 500 gross tonnage, such pumps may be omitted provided that the above services are ensured by means of equivalent arrangements, subject to the approval of the Society.

2.2 Bilge system

2.2.1 Bilge pumps

- At least one bilge pump is to be provided for draining the spaces located within the cargo area. Cargo pumps or stripping pumps may be used for this purpose.
- Bilge pumps serving spaces located within the cargo area are to be located in the cargo pump room or in another suitable space within the cargo area.

2.2.2 Draining of spaces located outside the cargo area

For bilge draining of spaces located outside the cargo area, refer to Pt C, Ch 1, Sec 10, [6].

Note 1: Where the bilge pumps are designed to pump from the machinery space only, the internal diameter d , in mm, of the bilge main may be less than that required in Pt C, Ch 1, Sec 10, [6.8.1] but it is not to be less than that obtained from the following formula:

$$d = 35 + 3 \sqrt{L_0(B+D)}$$

where:

L_0 : Length of the engine room, in m

- B : Breadth of the ship, in m
D : Moulded depth of the ship to the bulkhead deck, in m.

In any case, the internal section of the bilge main is not to be less than twice that of the bilge suction pipes determined from Pt C, Ch 1, Sec 10, [6.8.3].

Attention is drawn to the requirements stated in Part C, Chapter 4 as regards the diameter to be adopted for the determination of fire pump capacity.

2.2.3 Draining of pump rooms

- a) Arrangements are to be provided to drain the pump rooms by means of power pumps or bilge ejectors.

Note 1: On tankers of less than 500 gross tonnage, the pump rooms may be drained by means of hand pumps with a suction diameter of not less than 50 mm.

- b) Cargo pumps or stripping pumps may be used for draining cargo pump rooms provided that:
- a screw-down non-return valve is fitted on the bilge suction, and
 - a remote control valve is fitted between the pump suction and the bilge distribution box.
- c) Bilge pipe diameter is not to be less than 50 mm.
- d) The bilge system of cargo pump rooms is to be capable of being controlled from outside.
- e) A high level alarm is to be provided. Refer to item d) of [3.5.2].

2.2.4 Draining of tunnels and pump rooms other than cargo pump rooms

Arrangements are to be provided to drain tunnels and pump rooms other than cargo pump rooms. Cargo pumps may be used for this service under the provisions of [2.2.3], item b).

2.2.5 Draining of cofferdams located at the fore and aft ends of the cargo spaces

- a) When they are not intended to be filled with water ballast, cofferdams located at the fore and aft ends of the cargo spaces are to be fitted with drainage arrangements.
- b) Aft cofferdams adjacent to the cargo pump room may be drained by a cargo pump in accordance with the provisions of [2.2.3], items b) and c), or by bilge ejectors.
- c) Cofferdams located at the fore end of the cargo spaces may be drained by the bilge or ballast pumps required in [2.1.4], or by bilge ejectors.
- d) Drainage of the after cofferdam from the engine room bilge system is not permitted.

Note 1: On tankers of less than 500 gross tonnage, cofferdams may be drained by means of hand pumps with a suction diameter of not less than 50 mm.

2.2.6 Drainage of other cofferdams and void spaces located within the cargo area

Other cofferdams and void spaces located within the cargo area and not intended to be filled with water ballast are to be fitted with suitable means of drainage.

2.3 Ballast system

2.3.1 General

- a) Every crude oil tanker of 20 000 tons deadweight and above and every product carrier of 30 000 tons deadweight and above is to be provided with segregated ballast tanks.
- b) Except where expressly permitted, ballast systems serving segregated ballast tanks are to be completely separated from the cargo oil and fuel oil systems.
- c) In oil tankers of 150 gross tonnage and above, no ballast water is normally to be carried in any fuel oil tank; see Pt C, Ch 1, Sec 10, [7.1.3].
- d) In:
- crude oil tankers of 20 000 tons deadweight and above
 - product carriers of 30 000 tons deadweight and above,
- no ballast water is to be carried in cargo tanks, except in exceptional cases.

2.3.2 Ballast pumps

- a) Ballast pumps are to be located in the cargo pump room, or a similar space within the cargo area not containing any source of ignition.
- b) Where installed in the cargo pump room, ballast pumps are to comply with the applicable provisions of [3.2.3].

Note 1: The above provisions do not apply to tankers having one of the following service notations:

- oil tanker, flash point > 60°C
- oil tanker, asphalt carrier
- FLS tanker, flash point > 60°C.

2.3.3 Pumping arrangements for ballast tanks within the cargo area

- a) Segregated ballast tanks located within the cargo area are to be served by two different means. At least one of these means is to be a pump or an eductor used exclusively for dealing with ballast.
- b) Pumps, ballast lines, vent lines and other similar equipment serving permanent ballast tanks shall be independent of similar equipment serving cargo tanks and of cargo tanks themselves. Discharge arrangements for permanent ballast tanks sited immediately adjacent to cargo tanks shall be outside machinery spaces and accommodation spaces. Filling arrangements may be in the machinery spaces provided that such arrangements ensure filling from tank deck level and a non-return valve and removable spool piece are fitted in the supply line outside the machinery space.
- c) An eductor situated in the cargo area using water power from pumps in the machinery spaces may be accepted as a means to discharge permanent ballast from tanks and/or double bottoms adjacent to cargo tanks, provided the supply line is above deck level and a non-return valve and removable spool piece are fitted in the supply line outside the machinery space (See Fig 1).

Figure 1 : Discharge arrangement

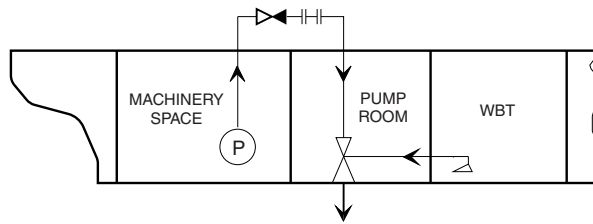

2.3.4 Pumping arrangement for cofferdams located at the fore and aft ends of the cargo spaces

Where they are intended to be filled with water ballast, the cofferdams located at the fore and aft ends of the cargo spaces may be emptied by a ballast pump located inside the machinery compartment or the forward space mentioned in [2.1.4], whichever is the case, provided that:

- the suction is directly connected to the pump and not to a piping system serving machinery spaces
- the delivery is directly connected to the ship side.

2.3.5 Emergency discharge of segregated ballast

Provisions may be made for emergency discharge of the segregated ballast by means of a connection to a cargo pump through a detachable spool piece provided that:

- non-return valves are fitted on the segregated ballast connections to prevent the passage of oil to the ballast tank, and
- shut-off valves are fitted to shut off the cargo and ballast lines before the spool piece is removed.

The detachable spool piece is to be placed in a conspicuous position in the pump room and a permanent warning notice restricting its use is to be permanently displayed adjacent to it.

2.3.6 Carriage of ballast water in cargo tanks

- a) Provisions are to be made for filling cargo tanks with sea water, where permitted. Such ballast water is to be processed and discharged using the equipment referred to in [5].
- b) The sea water inlets and overboard discharges serving cargo tanks for the purpose of a) are not to have any connection with the ballast system of segregated ballast tanks.
- c) Cargo pumps may be used for pumping ballast water to or from the cargo tanks, provided two shut-off valves are fitted to isolate the cargo piping system from the sea inlets and overboard discharges.
- d) Ballast pumps serving segregated ballast tanks may be used for filling the cargo tanks with sea water provided that the connection is made on the top of the tanks and consists of a detachable spool piece and a screw-down non-return valve to avoid siphon effects.

2.3.7 Ballast pipes passing through tanks

- a) In oil tankers of 600 tons deadweight and above, ballast piping is not to pass through cargo tanks except in the case of short lengths of piping complying with [2.1.3], item b).
- b) Sliding type couplings are not to be used for expansion purposes where ballast lines pass through cargo tanks. Expansion bends only are permitted.

2.3.8 Fore peak ballast system

The fore peak tank may be ballasted with the system serving other ballast tanks within the cargo area, provided:

- the fore peak tank is considered as a hazardous area, and the hazardous area classification is defined in accordance with Ch 7, Sec 5
- the vent pipe openings are located on open deck at an appropriate distance from sources of ignition. In this respect, the hazardous zones distances are to be defined in accordance with Ch 7, Sec 5
- means are provided, on the open deck, to allow measurement of flammable gas concentrations within the tank by a suitable portable instrument
- the access to the fore peak tank is direct from open deck. Alternatively, indirect access from the open deck to the fore peak tank through an enclosed space may be accepted provided that:
 - In case the enclosed space is separated from the cargo tanks by cofferdams, the access is through a gas tight bolted manhole located in the enclosed space and a warning sign is provided at the manhole stating that the fore peak tank may only be opened after:
 - it has been proven to be gas free; or
 - any electrical equipment which is not certified safe in the enclosed space is isolated.
 - In case the enclosed space has a common boundary with the cargo tanks and is therefore a hazardous area, the enclosed space can be well ventilated.

2.4 Air and sounding pipes of spaces other than cargo tanks

2.4.1 Application

The provisions of [2.4] do not apply to ships having one of the following service notations:

- **oil tanker, flash point > 60°C**
- **oil tanker, asphalt carrier**
- **FLS tanker, flash point > 60°C.**

2.4.2 General

The air and sounding pipes fitted to the following spaces:

- cofferdams located at the fore and aft ends of the cargo spaces
- tanks and cofferdams located within the cargo area and not intended for cargo

are to be led to the open.

2.4.3 Air pipes

The air pipes referred to in [2.4.2] are to be arranged as per Pt C, Ch 1, Sec 10, [9] and are to be fitted with easily removable flame screens at their outlets.

2.4.4 Passage through cargo tanks

In oil tankers of 600 tons deadweight and above, the air and sounding pipes referred to in [2.4.2] are not to pass through cargo tanks except in the following cases:

- short lengths of piping serving ballast tanks
- lines serving double bottom tanks located within the cargo area, except in the case of oil tankers of 5 000 tons deadweight and above

where the provisions of [2.1.3], item b) are complied with.

2.5 Scupper pipes

2.5.1 Scupper pipes are not to pass through cargo tanks except, where this is impracticable, in the case of short lengths of piping complying with the following provisions:

- they are of steel
- they have only welded or heavy flanged joints the number of which is kept to a minimum
- they are of substantial wall thickness as per Pt C, Ch 1, Sec 10, Tab 25, column 1.

2.6 Heating systems intended for cargo

2.6.1 General

- a) Heating systems intended for cargo are to comply with the relevant requirements of Pt C, Ch 1, Sec 10.
- b) No part of the heating system is normally to exceed 220°C.
- c) Blind flanges or similar devices are to be provided on the heating circuits fitted to tanks carrying cargoes which are not to be heated.

- d) Heating systems are to be so designed that the pressure maintained in the heating circuits is higher than that exerted by the cargo oil. This need not be applied to heating circuits which are not in service provided they are drained and blanked-off.
 - e) Isolating valves are to be provided at the inlet and outlet connections of the tank heating circuits. Arrangements are to be made to allow manual adjustment of the flow.
- ⁴ Heating pipes and coils inside tanks are to be built of a material suitable for the heated fluid and of reinforced thickness as per Pt C, Ch 1, Sec 10, Tab 6. They are to have welded connections only.

2.6.2 Steam heating

To reduce the risk of liquid or gaseous cargo returns inside the engine or boiler rooms, steam heating systems of cargo tanks are to satisfy either of the following provisions:

- they are to be independent of other ship services, except cargo heating or cooling systems, and are not to enter machinery spaces, or
- they are to be provided with an observation tank on the water return system located within the cargo area. However, this tank may be placed inside the engine room in a well-ventilated position remote from boilers and other sources of ignition. Its air pipe is to be led to the open and fitted with a flame arrester.

2.6.3 Hot water heating

Hot water systems serving cargo tanks are to be independent of other systems. They are not to enter machinery spaces unless the expansion tank is fitted with:

- means for detection of flammable vapours
- a vent pipe led to the open and provided with a flame arrester.

2.6.4 Thermal oil heating

Thermal oil heating systems serving cargo tanks are to be arranged by means of a separate secondary system, located completely within the cargo area. However, a single circuit system may be accepted provided that:

- the system is so arranged as to ensure a positive pressure in the coil of at least 3 m water column above the static head of the cargo when the circulating pump is not in operation
- the thermal oil system expansion tank is to be fitted with high and low level alarms
- means are provided in the expansion tank for detection of flammable cargo vapours. Portable equipment may be accepted
- valves for the individual heating coils are provided with a locking arrangement to ensure that the coils are under static pressure at all times.

3 Cargo pumping and piping systems

3.1 General

3.1.1 A complete system of pumps and piping is to be fitted for handling the cargo oil. Except where expressly permitted, and namely for the bow and stern cargo loading and unloading stations, this system is not to extend outside the cargo area and is to be independent of any other piping system on board.

3.2 Cargo pumping system

3.2.1 Number and location of cargo pumps

- a) Each cargo tank is to be served by at least two separate fixed means of discharging and stripping. However, for tanks fitted with an individual submerged pump, the second means may be portable.
- b) Cargo pumps are to be located:
 - in a dedicated pump room, or
 - on deck, or
 - when designed for this purpose, within the cargo tanks.

3.2.2 Use of cargo pumps

- ⁴ Except where expressly permitted in [2.2] and [2.3], cargo pumps are to be used exclusively for handling the liquid cargo and are not to have any connections to compartments other than cargo tanks.
- ⁵ Subject to their performance, cargo pumps may be used for tank stripping.
- ⁶ Cargo pumps may be used, where necessary, for the washing of cargo tanks.

3.2.3 Cargo pumps drive

- a) Prime movers of cargo pumps are not to be located in the cargo area, except in the following cases:
 - steam driven machine supplied with steam having a temperature not exceeding 220°C
 - hydraulic motors
 - electric motors in accordance with Ch 7, Sec 5, [2].
- b) Pumps with a submerged electric motor are not permitted in cargo tanks.
- c) Where cargo pumps are driven by a machine which is located outside the cargo pump room, the provisions of item a) of [3.5.2] are to be complied with.

3.2.4 Design of cargo pumps

- a) Materials of cargo pumps are to be suitable for the products carried.
- b) The delivery side of cargo pumps is to be fitted with relief valves discharging back to the suction side of the pumps (bypass) in closed circuit. Such relief valves may be omitted in the case of centrifugal pumps with a maximum delivery pressure not exceeding the design pressure of the piping, with the delivery valve closed.
- c) Pump casings are to be fitted with temperature sensing devices; see Tab 4.

Note 1: The provisions of item c) above do not apply to ships having one of the following service notations:

- **oil tanker, flash point > 60°C**
- **oil tanker, asphalt carrier**
- **FLS tanker, flash point > 60°C.**

3.2.5 Monitoring of cargo pumps

Cargo pumps are to be monitored as required in Tab 4.

Table 4 : Monitoring of cargo pumps

Equipment, parameter	Alarm	Indication	Comments
pump, discharge pressure	L	Local	<ul style="list-style-type: none"> • on the pump (1), or • next to the unloading control station
pump casing, temperature (2)	H (2)		visual and audible, in cargo control room or pump control station
bearings, temperature (2)	H (2)		visual and audible, in cargo control room or pump control station
bulkhead shaft gland, temperature (2)	H (2)		visual and audible, in cargo control room or pump control station
(1) and next to the driving machine if located in a separate compartment (2) not required for tankers having one of the following service notations: <ul style="list-style-type: none"> • oil tanker, flash point > 60°C • oil tanker, asphalt carrier • FLS tanker, flash point > 60°C. 			

3.2.6 Control of cargo pumps

Cargo pumps are to be capable of being stopped from:

- a position outside the pump room, and
- a position next to the pumps.

3.3 Cargo piping design

3.3.1 General

- a) Unless otherwise specified, cargo piping is to be designed and constructed according to the requirements of Pt C, Ch 1, Sec 10 applicable to piping systems of:
 - class III, in the case of ships having the service notation **oil tanker**
 - class II, in the case of ships having the service notation **FLS tanker**, with the exception of cargo pipes and accessories having an open end or situated inside cargo tanks, for which class III may be accepted.
- b) For tests, refer to [6].

3.3.2 Materials

- a) *For the protection of cargo tanks carrying crude oil and petroleum products having a flash point not exceeding 60°C, materials readily rendered ineffective by heat are not to be used for valves, fittings, cargo vent piping and cargo piping so as to prevent the spread of fire to the cargo.*
- b) Cargo piping is, in general, to be made of steel or cast iron.
- c) Valves, couplings and other end fittings of cargo pipe lines for connection to hoses are to be of steel or other suitable ductile material.

- d) Spheroidal graphite cast iron may be used for cargo oil piping within the double bottom or cargo tanks.
- e) Grey cast iron may be accepted for cargo oil lines:
- within cargo tanks, and
 - on the weather deck for pressure up to 1,6 Mpa.
- It is not to be used for manifolds and their valves or fittings connected to cargo handling hoses.
- f) Plastic pipes may be used in the conditions specified in Pt C, Ch 1, App 3. Arrangements are to be made to avoid the generation of static electricity.

3.3.3 Connection of cargo pipe lengths

Cargo pipe lengths may be connected either by means of welded joints or, unless otherwise specified, by means of flange connections.

3.3.4 Expansion joints

- a) Where necessary, cargo piping is to be fitted with expansion joints or bends.
- b) Expansion joints including bellows are to be of a type approved by the Society.
- c) Expansion joints made of non-metallic material may be accepted only inside tanks and provided they are:
- of an approved type
 - designed to withstand the maximum internal and external pressure
 - electrically conductive.
- d) In ships having the service notation **oil tanker**, sliding type couplings are not to be used for expansion purposes where lines for cargo oil pass through tanks for segregated ballast.
- e) In ships having the service notation **FLS tanker**, slip joints are not to be used for cargo piping systems with the exception of pipe sections inside cargo tanks served by such sections.

3.3.5 Valves with remote control

- a) Valves with remote control are to comply with Pt C, Ch 1, Sec 10, [2.7.3].
- b) Submerged valves are to be remote controlled. In the case of a hydraulic remote control system, control boxes are to be provided outside the tank, in order to permit the emergency control of valves.
- c) Valve actuators located inside cargo tanks are not to be operated by means of compressed air.

3.3.6 Cargo hoses

- a) Cargo hoses are to be of a type approved by the Society for the intended conditions of use.
- b) Hoses subject to tank pressure or pump discharge pressure are to be designed for a bursting pressure not less than 5 times the maximum pressure under cargo transfer conditions.
- c) Unless bonding arrangements complying with Section 6 are provided, the ohmic electrical resistance of cargo hoses is not to exceed $10^6 \Omega$.

3.4 Cargo piping arrangement and installation

3.4.1 Cargo pipes passing through tanks or compartments

- a) Cargo piping is not to pass through tanks or compartments located outside the cargo area.
- b) Cargo piping and similar piping to cargo tanks is not to pass through ballast tanks except in the case of short lengths of piping complying with [2.1.3], item b).
- c) Cargo piping may pass through vertical fuel oil tanks adjacent to cargo tanks on condition that the provisions of [2.1.3], item b) are complied with.
- d) Cargo piping passing through cargo tanks is to comply with the provisions of Ch 7, Sec 2, [3.4.1].

3.4.2 Cargo piping passing through bulkheads

Cargo piping passing through bulkheads is to be so arranged as to preclude excessive stresses at the bulkhead. Bolted flanges are not to be used in the bulkhead.

3.4.3 Valves

- a) Stop valves are to be provided to isolate each tank.
- b) A stop valve is to be fitted at each end of the cargo manifold.
- c) When a cargo pump in the cargo pump room serves more than one cargo tank, a stop valve is to be fitted in the cargo pump room on the line leading to each tank.

- d) Main cargo oil valves located in the cargo pump room below the floor gratings are to be remote controlled from a position above the floor.
- e) Valves are also to be provided where required by Ch 7, Sec 2, [3.4.1].

3.4.4 Prevention of the generation of static electricity

- a) In order to avoid the generation of static electricity, the loading pipes are to be led as low as practicable in the tank.
- b) Cargo pipe sections and their accessories are to be electrically bonded together and to the ship’s hull.

Note 1: The provisions of [3.4.4] do not apply to ships having one of the following service notations:

- oil tanker / flash point > 60°C
- oil tanker / asphalt carrier
- FLS tanker, flash point > 60°C.

3.4.5 Bow or stern cargo loading and unloading arrangements

Where the ship is arranged for loading and unloading outside the cargo area, the following provisions are to be complied with:

- a) the piping outside the cargo area is to be fitted with a shut-off valve at its connection with the piping system within the cargo area and separating means such as blank flanges or removable spool pieces are to be provided when the piping is not in use, irrespective of the number and type of valves in the line
- b) the shore connection is to be fitted with a shut-off valve and a blank flange
- c) pipe connections outside the cargo area are to be of welded type only
- d) arrangements are made to allow the piping outside the cargo area to be efficiently drained and purged.

Note 1: The provisions of [3.4.5] do not apply to ships having one of the following service notations:

- oil tanker / flash point > 60°C
- oil tanker / asphalt carrier
- FLS tanker, flash point > 60°C.

3.4.6 Draining of cargo pumps and oil lines

Every oil tanker required to be provided with segregated ballast tanks or fitted with a crude oil washing system is to comply with the following requirements:

- a) it is to be equipped with oil piping so designed and installed that oil retention in the lines is minimised, and
- b) means are to be provided to drain all cargo pumps and all oil lines at the completion of cargo discharge, where necessary by connection to a stripping device. The line and pump drainings are to be capable of being discharged both ashore and to a cargo tank or slop tank. For discharge ashore, a special small diameter line having a cross-sectional area not exceeding 10% of the main cargo discharge line is to be provided and is to be connected on the downstream side of the tanker’s deck manifold valves, both port and starboard, when the cargo is being discharged; see Fig 2.

For oil tankers fitted with a crude oil washing system, refer also to Ch 7, App 2, [2.4.5].

Figure 2 : Connection of small diameter line to the manifold valve

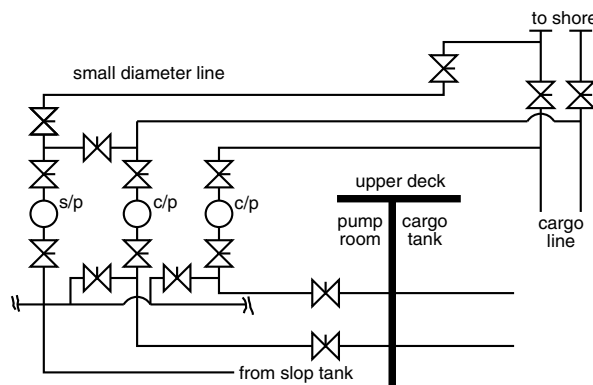

3.4.7 Cleaning and gas-freeing

- a) The cargo piping system is to be so designed and arranged as to permit its efficient cleaning and gas-freeing.
- b) Requirements for inert gas systems are given in Ch 7, Sec 6, [5].

3.5 Arrangement of cargo pump rooms

3.5.1 Pump room ventilation

In addition to the provisions of Ch 7, Sec 2, [2.3.3], the ventilation of the cargo pump room is to comply with the following provisions:

- a) *Cargo pump rooms are to be mechanically ventilated and discharges from exhaust fans are to be led to a safe place on the open deck. The ventilation of these rooms is to have sufficient capacity to minimize the possibility of accumulation of flammable vapours. The number of changes of air is to be at least 20 per hour, based upon the gross volume of the space. The air ducts are to be arranged so that all of the space is effectively ventilated. The ventilation is to be of the suction type using fans of the non-sparking type.*
- b) The ventilation ducts are to be so arranged that their suction is just above the transverse floor plates or bottom longitudinals in the vicinity of bilges.
- c) An emergency intake located about 2 m above the pump room lower grating is to be provided. It is to be fitted with a damper capable of being opened or closed from the exposed main deck and lower grating level.
Ventilation through the emergency intake is to be effective when the lower intakes are sealed off due to flooding in the bilges.
- d) The foregoing exhaust system is in association with open grating floor plates to allow the free flow of air.
- e) Arrangements involving a specific ratio of areas of upper emergency and lower main ventilator openings, which can be shown to result in at least the required 20 air changes per hour through the lower inlets, can be adopted without the use of dampers. When the lower access inlets are closed then at least 15 air changes per hour should be obtained through the upper inlets.

3.5.2 Measures to prevent explosions

The provisions of [3.5.2] do not apply to ships having one of the following service notations:

- **oil tanker, flash point > 60°C**
- **oil tanker, asphalt carrier**
- **FLS tanker, flash point > 60°C,**

except where the cargo is carried at a temperature within 15°C of its flash point.

- a) Where cargo pumps, ballast pumps and stripping pumps are driven by a machine which is located outside the cargo pump room, the following arrangements are to be made:
 - 1) drive shafts are to be fitted with flexible couplings or other means suitable to compensate for any misalignment
 - 2) the shaft bulkhead or deck penetration is to be fitted with a gas-tight gland of a type approved by the Society. The gland is to be efficiently lubricated from outside the pump room and so designed as to prevent overheating. The seal parts of the gland are to be of a material that cannot initiate sparks. The glands are to be constructed and fitted in accordance with the relative rules for fittings attached to watertight bulkheads, and if a bellows piece is incorporated in the design, it should be pressure tested before fitting.
 - 3) *Temperature sensing devices are to be fitted for bulkhead shaft glands, bearings and pump casings. A continuous audible and visual alarm signal shall be automatically effected in the cargo control room or the pump control station.*
- b) To discourage personnel from entering the cargo pump room when the ventilation is not in operation, the *lighting in the cargo pump room is to be interlocked with ventilation such that ventilation is to be in operation to energise the lighting.*
Failure of the ventilation system is not to cause the lighting to go out.
Where the lighting in cargo pump rooms can be commonly used as the emergency lighting, this lighting should be interlocked with the ventilation systems. However, this interlock should not prevent operation of the emergency lighting in case of loss of the main source of electrical power.
- c) *A system for continuously monitoring the concentration of hydrocarbon gases is to be fitted. Sampling points or detector heads are to be located in suitable positions in order that potentially dangerous leakages are readily detected. Sequential sampling is acceptable as long as it is dedicated for the pump room only, including exhaust ducts, and the sampling time is reasonably short. Detection positions are the zones where air circulation is reduced (e.g. recessed corners). When the hydrocarbon gas concentration reaches a pre-set level, which shall not be higher than 10 per cent of the lower flammable limit (LFL), a continuous audible and visual alarm signal shall be automatically effected in the pump room, engine control room, cargo control room and navigation bridge to alert personnel to the potential hazard.*
- d) *All pump rooms are to be provided with bilge level monitoring devices together with appropriately located alarms or bilge high level alarms.*
High liquid level in the bilges is to activate an audible and visual alarm in the cargo control room and on the navigation bridge.

3.6 Design of integrated cargo and ballast systems on tankers

3.6.1 Application

The following requirements are applicable to integrated cargo and ballast systems installed on tankers (i.e. cargo ships constructed or adapted for the carriage of liquid cargoes in bulk), irrespective of the size or type of the tanker.

Within the scope of these requirements, integrated cargo and ballast system means any integrated hydraulic and/or electric system used to drive both cargo and ballast pumps (including active control and safety systems and excluding passive components, e.g. piping).

3.6.2 Functional requirements

The operation of cargo and/or ballast systems may be necessary, under certain emergency circumstances or during the course of navigation, to enhance the safety of tankers.

As such, measures are to be taken to prevent cargo and ballast pumps becoming inoperative simultaneously due to a single failure in the integrated cargo and ballast system, including its control and safety systems.

3.6.3 Design features

The following design features are, inter alia, to be fitted:

- a) The emergency stop circuits of the cargo and ballast systems are to be independent from the circuits for the control systems. A single failure in the control system circuits or the emergency stop circuits are not to render the integrated cargo and ballast system inoperative.
- b) Manual emergency stops of the cargo pumps are to be arranged in a way that they are not to cause the stop of the power pack making ballast pumps inoperable.
- c) The control systems are to be provided with backup power supply, which may be satisfied by a duplicate power supply from the main switch board. The failure of any power supply is to provide audible and visible alarm activation at each location where the control panel is fitted.
- d) In the event of failure of the automatic or remote control systems, a secondary means of control is to be made available for the operation of the integrated cargo and ballast system. This is to be achieved by manual overriding and/or redundant arrangements within the control systems.

4 Cargo tanks and fittings

4.1 Application

4.1.1

- a) The provisions of Article [4] apply to cargo tanks and slop tanks.
- b) The provisions of Article [4] apply for the various service notations in accordance with Tab 5.

Table 5 : Requirements applicable to cargo tanks according to the service notations

Reference of item	Subject	Service notations to which the item applies	Substitutive requirements for service notations to which the item does not apply
[4.2]	tank venting	<ul style="list-style-type: none"> • oil tanker • FLS tanker 	<ul style="list-style-type: none"> • The relevant provisions of Pt C, Ch 1, Sec 10, [9] and Pt C, Ch 1, Sec 10, [11] are to be complied with. • Tank venting systems are to open to the atmosphere at a height of at least 760 mm above the weather deck (1). • Tanks may be fitted with venting systems of the open type provided with a flame screen.
[4.3]	tank purging/ gas-freeing	<ul style="list-style-type: none"> • oil tanker • FLS tanker 	No requirement
[4.4]	tank level gauging	<ul style="list-style-type: none"> • oil tanker • FLS tanker 	<ul style="list-style-type: none"> • The relevant provisions of Pt C, Ch 1, Sec 10, [9] and Pt C, Ch 1, Sec 10, [11] are to be complied with. • Tanks may be fitted with gauging systems of the open type, such as a hand sounding pipe or other portable gauging devices.
[4.5]	protection against tank overload	<ul style="list-style-type: none"> • oil tanker • oil tanker, flash point > 60°C • oil tanker, asphalt carrier • FLS tanker • FLS tanker, flash point > 60°C 	
[4.6]	tank washing	<ul style="list-style-type: none"> • oil tanker • oil tanker, flash point > 60°C • oil tanker, asphalt carrier 	
(1) For ships having the notation oil tanker, flash point > 60°C and carrying bulk cargoes at a temperature exceeding flash point-15°C, this height is to be increased to 2,4 m.			

4.2 Cargo tank venting

4.2.1 Principle

Cargo tanks are to be provided with venting systems *entirely distinct from the air pipes of the other compartments of the ship. The arrangements and position of openings in the cargo tank deck from which emission of flammable vapours can occur are to be such as to minimise the possibility of flammable vapours being admitted to enclosed spaces containing a source of ignition, or collecting in the vicinity of deck machinery and equipment which may constitute an ignition hazard.*

4.2.2 Design of venting arrangements

The venting arrangements are to be so designed and operated as to ensure that neither pressure nor vacuum in cargo tanks exceeds design parameters and be such as to provide for:

- a) *the flow of the small volumes of vapour, air or inert gas mixtures caused by thermal variations in a cargo tank in all cases through pressure/vacuum valves, and*
- b) *the passage of large volumes of vapour, air or inert gas mixtures during cargo loading and ballasting, or during discharging,*
- c) *a secondary means of allowing full flow relief of vapour, air or inert gas mixtures to prevent overpressure or underpressure in the event of failure of the arrangements in b). In addition, the secondary means shall be capable of preventing over-pressure or under-pressure in the event of damage to, or inadvertent closing of, the means of isolation required in [4.2.3] item b). Alternatively, pressure sensors may be fitted in each tank protected by the arrangement required in b), with a monitoring system in the ship's cargo control room or the position from which cargo operations are normally carried out. Such monitoring equipment is also to provide an alarm facility which is activated by detection of overpressure or underpressure conditions within a tank.*

Note 1: Note 1: For ships that apply pressure sensors in each tank as an alternative secondary means of venting as allowed above, the setting of the over-pressure alarm shall be above the pressure setting of the P/V valve and the setting of the under-pressure alarm shall be below the vacuum setting of the P/V valve. The alarm settings are to be within the design pressures of the cargo tanks. The settings are to be fixed and not arranged for blocking or adjustment in operation. However, for ships that carry different types of cargo and use P/V valves with different settings (one setting for each type of cargo), the settings may be adjusted to account for the different types of cargo.

4.2.3 Combination of venting arrangements

- a) *The venting arrangements in each cargo tank may be independent or combined with other cargo tanks and may be incorporated into the inert gas piping.*
- b) *Where the arrangements are combined with other cargo tanks, either stop valves or other acceptable means are to be provided to isolate each cargo tank. Where stop valves are fitted, they are to be provided with locking arrangements which are to be under the control of the responsible ship's officer. There is to be a clear visual indication of the operational status of the valves or other acceptable means. Where tanks have been isolated, it is to be ensured that relevant isolating valves are opened before cargo loading or ballasting or discharging of those tanks is commenced. Any isolation must continue to permit the flow caused by thermal variations in a cargo tank in accordance with [4.2.2].
Any isolation shall also continue to permit the passage of large volumes of vapour, air or inert gas mixtures during cargo loading and ballasting, or during discharging in accordance with [4.2.2].*
- c) *If cargo loading and ballasting or discharging of a cargo tank or cargo tank group is intended, which is isolated from a common venting system, that cargo tank or cargo tank group is to be fitted with a means for overpressure or underpressure protection as required in [4.2.2].*

4.2.4 Arrangement of vent lines

The venting arrangements are to be connected to the top of each cargo tank and are to be self-draining to the cargo tanks under all normal conditions of trim and list of the ship. Where it may not be possible to provide self-draining lines, permanent arrangements are to be provided to drain the vent lines to a cargo tank.

Plugs or equivalent means are to be provided on the lines after the safety relief valves.

4.2.5 Pressure/vacuum valves

- a) *Pressure/vacuum valves are to be set at a positive pressure not exceeding 0,021 N/mm² and at a negative pressure not exceeding 0,007 N/mm².*
- Note 1: Higher setting values not exceeding 0,07 N/mm² may be accepted in positive pressure if the scantlings of the tanks are appropriate.*
- b) *Pressure/vacuum valves required by [4.2.2] may be provided with a bypass when they are located in a vent main or masthead riser. Where such an arrangement is provided, there are to be suitable indicators to show whether the bypass is open or closed.*
 - c) *Pressure/vacuum valves are to be of a type approved by the Society in accordance with Ch 7, App 1.*
 - d) *Pressure/vacuum valves are to be readily accessible.*
 - e) *Pressure/vacuum valves are to be provided with a manual opening device so that valves can be locked on open position. Locking means on closed position are not permitted.*

4.2.6 Vent outlets

Openings for pressure release required by [4.2.2] item a) and vent outlets for cargo loading, discharging and ballasting required by [4.2.2] item b) are to:

- a) permit:
 - the free flow of vapour mixtures, or
 - the throttling of the discharge of the vapour mixtures to achieve a velocity of not less than 30 m/s,
- b) be so arranged that the vapour mixture is discharged vertically upwards,
- c) where the method is by free flow of vapour mixtures, be such that the outlet is not less than 6 m above the cargo tank deck or fore and aft gangway if situated within 4 m of the gangway and located not less than 10 m measured horizontally from the nearest air intakes and openings to enclosed spaces containing a source of ignition and from deck machinery, which may include anchor windlass and chain locker openings, and equipment which may constitute an ignition hazard,
- d) where the method is by high velocity discharge, be located at a height not less than 2 m above the cargo tank deck and not less than 10 m measured horizontally from the nearest air intakes and openings to enclosed spaces containing a source of ignition and from deck machinery, which may include anchor windlass and chain locker openings, and equipment which may constitute an ignition hazard. These outlets are to be provided with high velocity devices of a type approved by the Society,
- e) be designed on the basis of the maximum designed loading rate multiplied by a factor of at least 1,25 to take account of gas evolution, in order to prevent the pressure in any cargo tank from exceeding the design pressure. The Master is to be provided with information regarding the maximum permissible loading rate for each cargo tank and in the case of combined venting systems, for each group of cargo tanks.

4.2.7 High velocity valves

- a) High velocity valves are to be readily accessible.
- b) High velocity valves not required to be fitted with flame arresters (see [4.2.8]) are not to be capable of being locked on open position.

4.2.8 Prevention of the passage of flame into the tanks

- a) The venting system is to be provided with devices to prevent the passage of flame into the cargo tanks. The design, testing and locating of these devices are to comply with Ch 7, App 1.
- b) A flame arresting device integral to the venting system may be accepted.
- c) Flame screens and flame arresters are to be designed for easy overhauling and cleaning.
- d) Ullage openings shall not be used for pressure equalization. They shall be provided with self-closing and tightly sealing covers. Flame arresters and screens are not permitted in these openings.

4.2.9 Prevention of liquid rising in the venting system

- a) Provisions are to be made to prevent liquid rising in the venting system; refer to [4.5].
- b) Cargo tanks gas venting systems are not to be used for overflow purposes.
- c) Spill valves are not considered equivalent to an overflow system.

4.2.10 Additional provisions for ships fitted with an inert gas system

- a) On ships fitted with an inert gas system, one or more pressure/vacuum-breaking devices are to be provided to prevent the cargo tanks from being subject to:
 - 1) a positive pressure in excess of the test pressure of the cargo tank if the cargo were to be loaded at the maximum rated capacity and all other outlets are left shut, and
 - 2) a negative pressure in excess of 700 mm water gauge if cargo were to be discharged at the maximum rated capacity of the cargo pumps and the inert gas blowers were to fail.Such devices are to be installed on the inert gas main unless they are installed in the venting system required by [4.2.1] or on individual cargo tanks.
- b) The location and design of the devices referred to in paragraph a) above are to be in accordance with requirements [4.2.1] to [4.2.9].

4.3 Cargo tank inerting, purging and/or gas-freeing

4.3.1 General

- a) Arrangements are to be made for purging and/or gas-freeing of cargo tanks. The arrangements are to be such as to minimise the hazards due to the dispersal of flammable vapours in the atmosphere and to flammable mixtures in a cargo tank. Accordingly, the provisions of [4.3.2] and [4.3.3], as applicable, are to be complied with.

- b) *The arrangements for inerting, purging or gas-freeing of empty tanks as required in Pt C, Ch 4, Sec 15, [13.2.1], item b), are to be to the satisfaction of the Society and are to be such that the accumulation of hydrocarbon vapours in pockets formed by the internal structural members in a tank is minimized.*
- c) Ventilation/gas-freeing lines between fans and cargo tanks are to be fitted with means, such as detachable spool pieces, to prevent any back-flow of hydrocarbon gases through the fans when they are not used.
- d) Discharge outlets are to be located at least 10 m measured horizontally from the nearest air intake and openings to enclosed spaces with a source of ignition and from deck machinery equipment which may constitute an ignition hazard.

4.3.2 Ships provided with an inert gas system

The following provisions apply to ships provided with an inert gas system:

- a) *On individual cargo tanks the gas outlet pipe, if fitted, is to be positioned as far as practicable from the inert gas / air inlet and in accordance with [4.2]. The inlet of such outlet pipes may be located either at the deck level or at not more than 1 m above the bottom of the tank.*
- b) *The cross-sectional area of such gas outlet pipe referred to in a) above is to be such that an exit velocity of at least 20 m/s can be maintained when any three tanks are being simultaneously supplied with inert gas. Their outlets are to extend not less than 2 m above deck level.*
- c) *Each gas outlet referred to in b) above is to be fitted with suitable blanking arrangements.*
- d) The arrangement of inert gas and cargo piping systems is to comply with the provisions of Pt C, Ch 4, Sec 15, [13.2.3], item b) 7).
- e) *The cargo tanks are first to be purged in accordance with the provisions of a) to d) above until the concentration of hydrocarbon vapours in the cargo tanks has been reduced to less than 2% by volume. Thereafter, gas-freeing may take place at the cargo tank deck level.*

4.3.3 Ships not provided with an inert gas system

When the ship is not provided with an inert gas system, the operation is to be such that the flammable vapour is discharged initially:

- a) *through the vent outlets as specified in [4.2.6], or*
- b) *through outlets at least 2 m above the cargo tank deck level with a vertical efflux velocity of at least 30 m/s maintained during the gas-freeing operation, or*
- c) *through outlets at least 2 m above the cargo tank deck level with a vertical efflux velocity of at least 20 m/s and which are protected by suitable devices to prevent the passage of flame.*

When the flammable vapour concentration at the outlet has been reduced to 30% of the lower flammable limit, gas-freeing may thereafter be continued at cargo tank deck level.

4.4 Cargo tank level gauging systems

4.4.1 General

- a) Each cargo or slop tank is to be fitted with a level gauging system indicating the liquid level along the entire height of the tank. Unless otherwise specified, the gauge may be portable or fixed with local reading.
- b) Gauging devices and their remote reading systems are to be type approved.
- c) Ullage openings and other gauging devices likely to release cargo vapour to the atmosphere are not to be arranged in enclosed spaces.

4.4.2 Definitions

- a) A “restricted gauging device” means a device which penetrates the tank and which, when in use, permits a small quantity of vapour or liquid to be exposed to the atmosphere. When not in use, the device is completely closed. Examples are sounding pipes.
- b) A “closed gauging device” means a device which is separated from the tank atmosphere and keeps tank contents from being released. It may:
 - penetrate the tank, such as float-type systems, electric probe, magnetic probe or protected sight glass,
 - not penetrate the tank, such as ultrasonic or radar devices.
- c) An “indirect gauging device” means a device which determines the level of liquid, for instance by means of weighing or pipe flow meter.

4.4.3 Tankers fitted with an inert gas system

- a) In tankers fitted with an inert gas system, the gauging devices are to be of the closed type.
- b) Use of indirect gauging devices will be given special consideration.

4.4.4 Tankers not fitted with an inert gas system

- a) In tankers not fitted with an inert gas system, the gauging devices are to be of the closed or restricted types. Ullage openings may be used only as a reserve sounding means and are to be fitted with a watertight closing appliance.
- b) Where restricted gauging devices are used, provisions are to be made to:
 - avoid dangerous escape of liquid or vapour under pressure when using the device
 - relieve the pressure in the tank before the device is operated.
- c) Where used, sounding pipes are to be fitted with a self-closing blanking device.

4.5 Protection against tank overfilling

4.5.1 General

- a) Provisions are to be made to guard against liquid rising in the venting system of cargo or slop tanks to a height which would exceed the design head of the tanks. This is to be accomplished by high level alarms or overflow control systems or other equivalent means, together with gauging devices and cargo tank filling procedures.

Note 1: For ships having the service notation **FLS tanker**, only high level alarms are permitted.

- b) Sufficient ullage is to be left at the end of tank filling to permit free expansion of liquid during carriage.
- c) High level alarms, overflow control systems and other means referred to in a) are to be independent of the gauging systems referred to in [4.4].

4.5.2 High level alarms

- a) High level alarms are to be type approved.
- b) High level alarms are to give an audible and visual signal at the control station, where provided.

4.5.3 Other protection systems

- a) Where the tank level gauging systems, cargo and ballast pump control systems and valve control systems are centralised in a single location, the provisions of [4.5.1] may be complied with by the fitting of a level gauge for the indication of the end of loading, in addition to that required for each tank under [4.4]. The readings of both gauges for each tank are to be as near as possible to each other and so arranged that any discrepancy between them can be easily detected.
- b) Where a tank can be filled only from other tanks, the provisions of [4.5.1] are considered as complied with.

4.6 Tank washing systems

4.6.1 General

- a) Adequate means are to be provided for cleaning the cargo tanks.
- b) Every crude oil tanker of 20 000 tons deadweight and above is to be fitted with a cargo tank cleaning system using crude oil washing and complying with Ch 7, App 2.
- c) Crude oil washing systems fitted on oil tankers other than crude oil tankers of 20 000 tons deadweight or above are to comply with the provisions of Ch 7, App 2 related to safety.

4.6.2 Washing machines

- a) Tank washing machines are to be of a type approved by the Society.
- b) Washing machines are to be made of steel or other electricity conducting materials with a limited propensity to produce sparks on contact.

4.6.3 Washing pipes

- a) Washing pipes are to be built, fitted, inspected and tested in accordance with the applicable requirements of Pt C, Ch 1, Sec 10, depending on the kind of washing fluid, water or crude oil.
- b) Crude oil washing pipes are also to satisfy the requirements of Article [3.3].

4.6.4 Use of crude oil washing machines for water washing operations

Crude oil washing machines may be connected to water washing pipes, provided that isolating arrangements, such as a valve and a detachable pipe section, are fitted to isolate water pipes.

4.6.5 Installation of washing systems

- a) Tank cleaning openings are not to be arranged in enclosed spaces.
- b) The complete installation is to be permanently earthed to the hull.

5 Prevention of pollution by cargo oil

5.1 General

5.1.1 Application

- a) Unless otherwise specified, the provisions of [5.3] apply only to ships having the service notations **oil tanker** or **oil tanker, flash point > 60°C** and of 150 gross tonnage and above.
- b) The provisions of Ch 7, Sec 2, [3.6] are to be complied with.

5.1.2 Provisions for oil tankers of less than 150 gross tonnage

The control of discharge for ships having the service notations **oil tanker** or **oil tanker, flash point > 60°C** and of less than 150 gross tonnage is to be effected by the retention of oil on board with subsequent discharge of all contaminated washings to reception facilities unless adequate arrangements are made to ensure that the discharge of any effluent which is allowed to be discharged into the sea is effectively monitored to ensure that the total quantity of oil discharged into the sea does not exceed 1/30 000 of the total quantity of the particular cargo of which the residue formed a part.

5.1.3 Exemptions

- a) The provisions of [5.3] may be waived in the following cases:
 - oil tankers which engage exclusively on both voyages of 72 hours or less in duration and within 50 miles from the nearest land, provided that the oil tanker is engaged exclusively in trades between ports or terminals within a State Party to MARPOL 73/78 Convention. Any such waiver is to be subject to the requirements that the oil tanker is to retain on board all oily mixtures for subsequent discharge to reception facilities and to the determination by the Administration that facilities available to receive such oily mixtures are adequate,
 - oil tankers carrying products which through their physical properties inhibit effective product/water separation and monitoring, for which the control of discharge is to be effected by the retention of residues on board with discharge of all contaminated washings to reception facilities.
- b) Where, in the view of the Society, the equipment referred to in [5.3.1] and [5.3.2] is not obtainable for the monitoring of discharge of oil refined products (white oils), compliance with such requirements may be waived provided that discharge is performed only in compliance with the applicable procedures.

5.2 Discharge into the sea of cargo oil or oily mixtures

5.2.1 Any discharge into the sea of cargo oil or oily mixtures is to be prohibited except when all the following conditions are satisfied:

- a) the tanker is not within a special area,
Note 1: Special areas are defined in MARPOL Annex I, regulation (9).
- b) the tanker is more than 50 nautical miles from the nearest land.
- c) the tanker is proceeding on route.
- d) the instantaneous rate of discharge of oil content does not exceed 30 litres per nautical mile.
- e) the total quantity of oil discharged into the sea does not exceed 1/30000 of the total quantity of the particular cargo of which the residue formed a part.
- f) the tanker has in operation an oil discharge and monitoring system complying with the provisions of [5.3] and a slop tank arrangement as required by Ch 7, Sec 2, [3.6].

5.2.2 The provisions of [5.2.1] are not to apply to the discharge of segregated ballast.

5.2.3 The cargo oil residues which cannot be discharged into the sea in compliance with [5.2.1] above are to be retained on board or discharged to reception facilities.

5.3 Oil discharge monitoring and control system

5.3.1 General

- a) An oil discharge monitoring and control system is to be fitted.
- b) A manually operated alternative method is to be provided.

5.3.2 Design of the discharge monitoring and control system

- a) The discharge monitoring and control system is to be of a type approved in compliance with the provisions of IMO Resolution MEPC 108(49), as amended.
- b) The discharge monitoring and control system is to be fitted with a recording device to provide a continuous record of the discharge in litres per nautical mile and total quantity discharged, or the oil content and rate of discharge. This record is to be identifiable as regards time and date.

- c) The oil discharge monitoring and control system is to come into operation when there is any discharge of effluent into the sea and is to be such as will ensure that any discharge of oily mixture is automatically stopped when the instantaneous rate of discharge of oil content exceeds 30 litres per nautical mile.
- d) Any failure of the monitoring and control system is to stop the discharge.

5.3.3 Oil/water interface detectors

Effective oil/water interface detectors approved by the Society are to be provided for a rapid and accurate determination of the oil/water interface in slop tanks and are to be available for use in other tanks where the separation of oil and water is effected and from which it is intended to discharge effluent directly to the sea.

5.4 Pumping, piping and discharge arrangements

5.4.1 Discharge manifold

In every oil tanker, a discharge manifold for connection to reception facilities for the discharge of dirty ballast water or oil contaminated water is to be located on the open deck on both sides of the ship.

5.4.2 Discharge pipelines

In every oil tanker, pipelines for the discharge of ballast water or oil contaminated water from cargo tank areas to the sea, where permitted, are to be led to the open deck or to the ship side above the waterline in the deepest ballast condition, except that:

- a) segregated ballast and clean ballast may be discharged below the waterline:
 - in ports or at offshore terminals, or
 - at sea by gravity,provided that the surface of the ballast water has been examined immediately before the discharge to ensure that no contamination with oil has taken place.
- b) on every oil tanker at sea, dirty ballast water or oil contaminated water from tanks in the cargo area, other than slop tanks, may be discharged by gravity below the waterline, provided that sufficient time has elapsed in order to allow oil/water separation to have taken place and the water ballast has been examined immediately before the discharge with an oil/water interface detector referred to in [5.3.3], in order to ensure that the height of the interface is such that the discharge does not involve any increased risk of harm to the marine environment.

5.4.3 Discharge stopping

Means are to be provided for stopping the discharge into the sea of ballast water or oil contaminated water from cargo tank areas, other than those discharges below the waterline permitted under [5.4.2], from a position on the upper deck or above located so that the manifold in use referred to in [5.4.1] and the discharge to the sea from the pipelines referred to in [5.4.2] may be visually observed. Means for stopping the discharge need not be provided at the observation position if a positive communication system such as a telephone or radio system is provided between the observation position and the discharge control position.

6 Certification, inspection and testing

6.1 Application

6.1.1 The provisions of this Article are related to cargo piping and other equipment fitted in the cargo area. They supplement those given in Pt C, Ch 1, Sec 10, [20] for piping systems.

6.2 Workshop tests

6.2.1 Tests for materials

Where required in Tab 6, materials used for pipes, valves and fittings are to be subjected to the tests specified in Pt C, Ch 1, Sec 10, [20.4.2].

6.2.2 Inspection of welded joints

Where required in Tab 6, welded joints are to be subjected to the examinations specified in Pt C, Ch 1, Sec 10, [3.6] for class II pipes.

6.2.3 Hydrostatic testing

- a) Where required in Tab 6, cargo pipes, valves, fittings and pump casings are to be submitted to hydrostatic tests in accordance with the relevant provisions of Pt C, Ch 1, Sec 10, [20.5].
- b) Expansion joints and cargo hoses are to be submitted to hydrostatic tests in accordance with the relevant provisions of Pt C, Ch 1, Sec 10, [20.5].
- c) Where fitted, bellow pieces of gas-tight penetration glands are to be pressure tested.

6.2.4 Tightness tests

Tightness of the following devices is to be checked:

- gas-tight penetration glands
- cargo tank P/V and high velocity valves.

Note 1: These tests may be carried out in the workshops or on board.

6.2.5 Check of the safety valves setting

The setting pressure of the pressure/vacuum valves is to be checked in particular with regard to [4.2.5].

6.2.6 Summarising table

Inspections and tests required for cargo piping and other equipment fitted in the cargo area are summarised in Tab 6.

6.3 Shipboard tests

6.3.1 Pressure test

- After installation on board, the cargo piping system is to be checked for leakage under operational conditions.
- The piping system used in crude oil washing systems is to be submitted to hydrostatic tests in accordance with Ch 7, App 2, [3.2.1].

Table 6 : Inspection and testing at works

No	Item	Tests for materials		Inspections and tests for the products			References to the Rules
		Y/N (1)	Type of material certificate (2)	during manufacturing (1)	after completion (1) (3)	Type of product certificate (2)	
1	pipes, valves and fittings of class II (see [3.3.1])	Y	<ul style="list-style-type: none"> • C where ND > 100mm • W where ND ≤ 100mm 	Y (4)	Y	C	[6.2.1] [6.2.1] [6.2.2] [6.2.3]
2	expansion joints and cargo hoses	Y (5)	W	N	Y	C	[6.2.1] [6.2.3]
3	cargo pumps	Y	<ul style="list-style-type: none"> • C for cast body • W for welded construction 	Y (6)	Y	C	see note (6) [6.2.3]
4	gas-tight penetration glands	N		N	Y	C	[6.2.3], [6.2.4]

- (1) Y = required, N = not required.
 (2) C = class certificate, W = works' certificate.
 (3) includes the checking of the rule characteristics according to the approved drawings.
 (4) only in the case of welded construction.
 (5) if metallic.
 (6) inspection during manufacturing is to be carried out according to a program approved by the Society.
 (7) may also be carried out on board.

No	Item	Tests for materials		Inspections and tests for the products			References to the Rules
		Y/N (1)	Type of material certificate (2)	during manufacturing (1)	after completion (1) (3)	Type of product certificate (2)	
5	cargo tank P/V and high velocity valves	Y	W	Y	Y	C	[6.2.1] [6.2.2] [6.2.3], [6.2.4]
6	flame arresters	N		N	Y	C	see note (3)
7	Oil discharge monitoring and control system	N			Y (7)	C	see note (3)
8	Oil/water interface detector	N			Y (7)	C	see note (3)
<p>(1) Y = required, N = not required. (2) C = class certificate, W = works' certificate. (3) includes the checking of the rule characteristics according to the approved drawings. (4) only in the case of welded construction. (5) if metallic. (6) inspection during manufacturing is to be carried out according to a program approved by the Society. (7) may also be carried out on board.</p>							

6.3.2 Survey of pollution prevention equipment

Every ship having the service notations **oil tanker** or **oil tanker, flash point > 60°C** and of 150 gross tonnage and above is to be subjected to an initial survey before the ship is put in service, to ensure that the equipment, systems, fittings, arrangements and materials fully comply with the relevant provisions of [4.6] and [5].

7 Steering gear

7.1 General

7.1.1 In addition to the provisions of Pt C, Ch 1, Sec 14, the steering gear of ships having the service notation **oil tanker** or **FLS tanker** and of 10000 gross tonnage and above is to comply with the requirements of [7].

7.2 Design of the steering gear

7.2.1 *In every tanker of 10 000 gross tonnage and upwards, the main steering gear shall comprise two or more identical power units complying with the provisions of Pt C, Ch 1, Sec 14, [2.4.2].*

7.2.2 *Every tanker of 10 000 gross tonnage and upwards is, subject to the provisions of [7.3], to comply with the following:*

- a) *the main steering gear is to be so arranged that in the event of loss of steering capability due to a single failure in any part of one of the power actuating systems of the main steering gear, excluding the tiller, quadrant or components serving the same purpose, or seizure of the rudder actuators, steering capability is to be regained in not more than 45 s after the loss of one power actuating system.*

- b) the main steering gear is to comprise either:
- 1) two independent and separate power actuating systems, each capable of meeting the requirements of Pt C, Ch 1, Sec 14, [2.2.1]; The two independent power actuating systems are to be so arranged that a mechanical or electrical failure in one of them will not render the other one inoperative, and be in accordance with Pt C, Ch 1, Sec 14, [2.3.3]; or
 - 2) at least two identical power actuating systems which, acting simultaneously in normal operation, are to be capable of meeting the requirements of Pt C, Ch 1, Sec 14, [2.2.1]. Where necessary to comply with this requirement, interconnection of hydraulic power actuating systems is to be provided. Loss of hydraulic fluid from one system is to be capable of being detected and the defective system automatically isolated so that the other actuating system or systems remain(s) fully operational
- c) steering gear other than that of the hydraulic type is to achieve equivalent standards.

7.3 Alternative design for ships of less than 100 000 tonnes deadweight

7.3.1 General

For tankers of 10 000 gross tonnage and upwards, but of less than 100 000 tons deadweight, solutions other than those set out in [7.2], which need not apply the single failure criterion to the rudder actuator or actuators, may be permitted provided that an equivalent safety standard is achieved and that:

- a) following loss of steering capability due to a single failure of any part of the piping system or in one of the power units, steering capability is regained within 45 s; and
- b) where the steering gear includes only a single rudder actuator, special consideration is given to stress analysis for the design including fatigue analysis and fracture mechanics analysis, as appropriate, to the material used, to the installation of sealing arrangements and to testing and inspection and to the provision of effective maintenance.

7.3.2 Materials

Parts subject to internal hydraulic pressure or transmitting mechanical forces to the rudder stock are to be made of duly tested ductile materials complying with recognised standards. Materials for pressure retaining components are to be in accordance with recognised pressure vessel standards. These materials are not to have an elongation of less than 12% or a tensile strength in excess of 650 N/mm².

7.3.3 Design

a) Design pressure

The design pressure is assumed to be at least equal to the greater of the following:

- 1) 1,25 times the maximum working pressure to be expected under the operating conditions required in Pt C, Ch 1, Sec 14, [2.2.1]
- 2) the relief valve setting.

b) Analysis

- 1) the manufacturers of rudder actuators are to submit detailed calculations showing the suitability of the design for the intended service
- 2) a detailed stress analysis of the pressure retaining parts of the actuator is to be carried out to determine the stress at the design pressure
- 3) where considered necessary because of the design complexity or manufacturing procedures, a fatigue analysis and fracture mechanics analysis may be required. In connection with the analyses, all foreseen dynamic loads are to be taken into account. Experimental stress analysis may be required in addition to, or in lieu of, theoretical calculations depending on the complexity of the design.

c) Allowable stresses

For the purpose of determining the general scantlings of parts of rudder actuators subject to internal hydraulic pressure, the allowable stresses are not to exceed:

- $\sigma_m \leq f$
- $\sigma_l \leq 1,5 f$
- $\sigma_b \leq 1,5 f$
- $\sigma_l + \sigma_b \leq 1,5 f$
- $\sigma_m + \sigma_b \leq 1,5 f$

where:

σ_m : Equivalent primary general membrane stress

σ_l : Equivalent primary local membrane stress

σ_b : Equivalent primary bending stress

f : The lesser of σ_B/A or σ_y/B

σ_B : Specified minimum tensile strength of material at ambient temperature

σ_y : Specified minimum yield stress or 0,2% proof stress of material at ambient temperature

- A : Equal to:
- 4,0 for steel
 - 4,6 for cast steel
 - 5,8 for nodular cast iron
- B : Equal to:
- 2,0 for steel
 - 2,3 for cast steel
 - 3,5 for nodular cast iron

d) Burst test

- 1) Pressure retaining parts not requiring fatigue analysis and fracture mechanics analysis may be accepted on the basis of a certified burst test at the discretion of the Society and the detailed stress analysis required by [7.3.3], item b), need not be provided.
- 2) The minimum bursting pressure is to be calculated as follows:

$$P_b = P \cdot A \cdot \frac{\sigma_{Ba}}{\sigma_B}$$

where:

- P_b : Minimum bursting pressure
 P : Design pressure as defined in [7.3.3], item a)
 A : As from [7.3.3], item c)
 σ_{Ba} : Actual tensile strength
 σ_B : Tensile strength as defined in [7.3.3], item c).

7.3.4 Construction details

a) General

The construction is to be such as to minimise the local concentration of stress.

b) Welds

- 1) The welding details and welding procedures are to be approved.
- 2) All welded joints within the pressure boundary of a rudder actuator or connecting parts transmitting mechanical loads are to be full penetration type or of equivalent strength.

c) Oil seals

- 1) Oil seals between non-moving parts, forming part of the external pressure boundary, are to be of the metal upon metal type or of an equivalent type.
- 2) Oil seals between moving parts, forming part of the external pressure boundary, are to be duplicated, so that the failure of one seal does not render the actuator inoperative. Alternative arrangements providing equivalent protection against leakage may be accepted at the discretion of the Society.

d) Isolating valves

Isolating valves are to be fitted at the connection of pipes to the actuator, and are to be directly mounted on the actuator.

e) Relief valves

Relief valves for protecting the rudder actuator against overpressure as required in Pt C, Ch 1, Sec 14, [2.6.5] are to comply with the following:

- 1) the setting pressure is not to be less than 1,25 times the maximum working pressure expected under operating conditions required in Pt C, Ch 1, Sec 14, [2.2.1], item b)
- 2) the minimum discharge capacity of the relief valves is not to be less than the total capacity of all pumps which provide power for the actuator, increased by 10 per cent. Under such conditions, the rise in pressure is not to exceed 10 per cent of the setting pressure. In this regard, due consideration is to be given to extreme foreseen ambient conditions in respect of oil viscosity.

7.3.5 Inspection and testing

a) Non-destructive testing

The rudder actuator is to be subjected to suitable and complete non-destructive testing to detect both surface flaws and volumetric flaws. The procedure and acceptance criteria for non-destructive testing is to be in accordance with requirements of recognised standards. If found necessary, fracture mechanics analysis may be used for determining maximum allowable flaw size.

b) Other testing

- 1) Tests, including hydrostatic tests, of all pressure parts at 1,5 times the design pressure are to be carried out.
- 2) When installed on board the ship, the rudder actuator is to be subjected to a hydrostatic test and a running test.

8 Additional requirements for ships having the additional service feature asphalt carrier

8.1 Application

8.1.1 The provisions of this Article apply, in addition to those contained in Articles [1] to [7] above, to oil tankers having the additional service feature **asphalt carrier**.

8.2 Additional requirements

8.2.1 Heating systems

- a) Cargo tanks intended for the carriage of asphalt solutions are to be equipped with a heating system capable of preserving the asphalt solutions in their liquid state. Valves are to be fitted on the heating system inlet and outlet.
- b) Cargo piping and associated fittings outside tanks are to be provided with suitable heating devices. For heating of piping and fittings, refer to [2.6].

8.2.2 Thermometers

Each tank is to be equipped with at least two thermometers in order to ascertain the temperature of the asphalt solution.

8.2.3 Insulation

Cargo piping and associated fittings outside tanks are to be suitably insulated, where necessary.

9 Specific requirements for ships having the notations “FLS tanker” or “FLS tanker, flash point > 60°C”

9.1 Application

9.1.1 The provisions of this Article, derived from Appendix II of the MARPOL 73/78 Convention, are related to the prevention of pollution by noxious liquid substances. They apply as follows:

- a) Where the ship is granted only the service notation **FLS tanker** or **FLS tanker, flash point > 60°C**, these provisions replace those of [5] related to the prevention of pollution by cargo oil.
- b) Where the ship is granted both service notations **oil tanker-FLS tanker**, or **oil tanker-FLS tanker, flash point > 60°C**, these provisions are additional to those of [5].

9.2 Design requirements

9.2.1 General

The requirements of [9.2] apply to ships carrying category Z substances (see Ch 7, App 3, Tab 2).

9.2.2 Underwater discharge

The underwater discharge outlet arrangement is to be such that the residue/water mixture discharged into the sea will not pass through the ship's boundary layer. To this end, when the discharge is made normal to the ship's shell plating, the minimum diameter of the discharge outlet is governed by the following equation:

$$D = \frac{Q_D}{5L}$$

where:

D : Minimum diameter of the discharge outlet, in m

L : Distance from the forward perpendicular to the discharge outlet, in m

Q_D : The maximum rate selected at which the ship may discharge a residue/water mixture through the outlet, in m³/h.

When the discharge is directed at an angle to the ship's shell plating, the above relationship is to be modified by substituting for Q_D the component of Q_D which is normal to the ship's shell plating.

9.2.3 Ventilation equipment

- a) If residues from cargo tanks are removed by means of ventilation, ventilation equipment meeting the following provisions is to be provided.

Note 1: Ventilation procedures may be applied only to those substances having a vapour pressure greater than $5 \cdot 10^3$ Pa at 20°C.

- b) The ventilation equipment is to be capable of producing an air jet which can reach the tank bottom. Fig 3 may be used to evaluate the adequacy of ventilation equipment used for ventilating a tank of given depth.
- c) The ventilation equipment is to be placed in the tank opening closest to the tank sump or suction point.

- d) When practicable, the ventilation equipment is to be positioned so that the air jet is directed at the tank sump or suction point and impingement of the air jet on tank structural members is to be avoided as far as possible.

Figure 3 : Minimum flow rate as a function of jet penetration depth

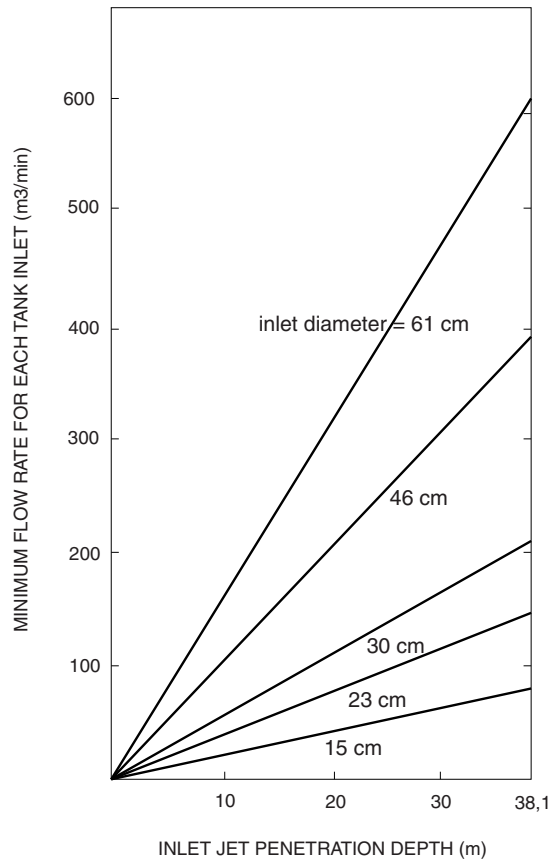

Jet penetration depth is to be compared against tank height.

Section 5 Electrical Installations

1 General

1.1 Application

1.1.1 The requirements in this Section apply, in addition to those contained in Part C, Chapter 2 to ships with the service notation **oil tanker** or **FLS tanker**.

1.1.2 The design is to be in accordance with IEC publication 60092-502.

However, where the prescriptive requirements in the present Rules and IEC 60092-502 are not aligned, the prescriptive requirements in the present Rules take precedence and are to be applied.

1.2 Documentation to be submitted

1.2.1 In addition to the documentation requested in Pt C, Ch 2, Sec 1, Tab 1, the following are to be submitted for approval:

- a) plan of hazardous areas
- b) document giving details of types of cables and safety characteristics of the equipment installed in hazardous areas
- c) diagrams of tank level indicator systems, high level alarm systems and overflow control systems where requested.

1.3 System of supply

1.3.1 The following systems of generation and distribution of electrical energy are acceptable:

- a) direct current:
 - two-wire insulated
- b) alternating current:
 - single-phase, two-wire insulated
 - three-phase, three-wire insulated.

1.3.2 Earthed systems with hull return are not permitted, with the following exceptions to the satisfaction of the Society:

- a) impressed current cathodic protective systems
- b) limited and locally earthed systems, such as starting and ignition systems of internal combustion engines, provided that any possible resulting current does not flow directly through any hazardous area
- c) insulation level monitoring devices, provided that the circulation current of the device does not exceed 30 mA under the most unfavourable conditions.

1.3.3 Earthed systems without hull return are not permitted, with the following exceptions:

- a) earthed intrinsically safe circuits and the following other systems to the satisfaction of the Society
- b) power supplies, control circuits and instrumentation circuits in non-hazardous areas where technical or safety reasons preclude the use of a system with no connection to earth, provided the current in the hull is limited to not more than 5 A in both normal and fault conditions, or
- c) limited and locally earthed systems, such as power distribution systems in galleys and laundries to be fed through isolating transformers with the secondary windings earthed, provided that any possible resulting hull current does not flow directly through any hazardous area, or
- d) alternating current power networks of 1,000 V root mean square (line to line) and over, provided that any possible resulting current does not flow directly through any hazardous area; to this end, if the distribution system is extended to areas remote from the machinery space, isolating transformers or other adequate means are to be provided.

1.3.4 In insulated distribution systems, no current carrying part is to be earthed, other than:

- a) through an insulation level monitoring device
- b) through components used for the suppression of interference in radio circuits.

1.4 Earth detection

1.4.1 The devices intended to continuously monitor the insulation level of all distribution systems are also to monitor all circuits, other than intrinsically safe circuits, connected to apparatus in hazardous areas or passing through such areas. An audible and visual alarm is to be given, at a manned position, in the event of an abnormally low level of insulation.

1.5 Mechanical ventilation of hazardous spaces

1.5.1 Electric motors driving fans of the ventilating systems of hazardous spaces are to be located outside the ventilation ducting.

1.5.2 Motors driving ventilating fans may be located within the ducting provided that they are of a certified safe type.

1.5.3 The materials used for the fans and their housing are to be in compliance with Pt C, Ch 4, Sec 1, [3.32].

1.5.4 Cargo pump-rooms and other enclosed spaces which contain cargo-handling equipment and similar spaces in which work is performed on the cargo should be fitted with mechanical ventilation systems, capable of being controlled from outside such spaces.

1.5.5 Provisions are to be made to ventilate the spaces defined in [1.5.4] prior to entering the compartment and operating the equipment.

1.6 Electrical installation precautions

1.6.1 Precautions against inlet of gases or vapours

Suitable arrangements are to be provided, to the satisfaction of the Society, so as to prevent the possibility of gases or vapours passing from a gas-dangerous space to another space through runs of cables or their conduits.

2 Hazardous locations and types of equipment

2.1 Special requirements for oil tankers carrying flammable liquids having a flash point not exceeding 60°C and for oil tankers carrying flammable liquids having a flash point exceeding 60°C heated to a temperature within 15°C of their flash point or above their flash point

2.1.1 In order to facilitate the selection of appropriate electrical apparatus and the design of suitable electrical installations, hazardous areas are divided into zone 0, 1 and 2 according to Pt C, Ch 2, Sec 1, [3.25.3]. The different spaces are to be classified according to Tab 1.

The types of electrical equipment admitted, depending on the zone where they are installed, are specified in Pt C, Ch 2, Sec 3, [10].

2.1.2 The explosion group and temperature class of electrical equipment of a certified safe type are to be at least IIA and T3 in the case of ships arranged for the carriage of crude oil or other petroleum products.

Other characteristics may be required for dangerous products other than those above.

2.1.3 A space separated by a gastight boundaries from a hazardous area may be classified as zone 0, 1, 2 or considered as non hazardous, taking into account the sources of release inside that space and its conditions of ventilation.

2.1.4 Access door and other openings are not to be provided between an area intended to be considered as non-hazardous and a hazardous area or between a space intended to be considered as zone 2 and a zone 1, except where required for operational reasons.

2.1.5 In enclosed or semi-enclosed spaces having a direct opening into any hazardous space or area, electrical installations are to comply with the requirements for the space or area to which the opening leads.

2.1.6 Where a space has an opening into an adjacent, more hazardous space or area, it may be made into a less hazardous space or non-hazardous space, taking into account the type of separation and the ventilation system.

2.1.7 A differential pressure monitoring device or a flow monitoring device, or both, are to be provided for monitoring the satisfactory functioning of pressurisation of spaces having an opening into a more hazardous zone.

In the event of loss of the protection by the over-pressure or loss of ventilation in spaces classified as zone 1 or zone 2, protective measures are to be taken.

2.2 Special requirements for oil tankers carrying flammable liquids having a flash point exceeding 60°C unheated or heated to a temperature below and not within 15°C of their flash point

2.2.1 For systems of supply and earth detection, the requirements under [1.3] and [1.4] apply.

2.2.2 Cargo tanks, slop tanks, any pipe work of pressure-relief or other venting systems for cargo and slop tanks, pipes and equipment containing the cargo are to be classified as zone 2.

2.3 Special requirements for FLS tankers

2.3.1 The requirements under Ch 8, Sec 10 apply.

Table 1 : Space descriptions and hazardous area zones for oil tankers carrying flammable liquids having a flash point not exceeding 60°C and for oil tankers carrying flammable liquids heated to a temperature within 15°C of their flash point or above their flash point

No.	Description of spaces	Hazardous area
1	The interior of cargo tanks, slop tanks, any pipework of pressure-relief or other venting systems for cargo and slop tanks, pipes and equipment containing the cargo or developing flammable gases and vapours	Zone 0
2	Void space adjacent to, above or below integral cargo tanks	Zone 1
3	Hold spaces	Zone 1
4	Cofferdams and permanent (for example, segregated) ballast tanks adjacent to cargo tanks	Zone 1
5	Cargo pump rooms	Zone 1
6	Enclosed or semi-enclosed spaces, immediately above cargo tanks (for example, between decks) or having bulkheads above and in line with cargo tank bulkheads, unless protected by a diagonal plate acceptable to the Society	Zone 1
7	Spaces, other than cofferdam, adjacent to and below the top of a cargo tank (for example, trunks, passageways and hold)	Zone 1
8	Areas on open deck, or semi-enclosed spaces on open deck, within 3 m of any cargo tank outlet, gas or vapour outlet, cargo manifold valve, cargo valve, cargo pipe flange and cargo pump-room ventilation outlets.	Zone 1
9	Areas on open deck, or semi-enclosed spaces on open deck above and in the vicinity of any cargo gas outlet intended for the passage of large volumes of gas or vapour mixture during cargo loading and ballasting or during discharging or of small volumes of gas or vapour mixtures caused by thermal variation, within a vertical cylinder of unlimited height and 6 m radius centred upon the centre of the outlet, and within a hemisphere of 6 m radius below the outlet	Zone 1
10	Areas on open deck, or semi-enclosed spaces on open deck, within 1,5 m of cargo pump entrances, cargo pump room ventilation inlet, openings into cofferdams, or other zone 1 spaces	Zone 1
11	Areas on open deck within spillage coamings surrounding cargo manifold valves and 3 m beyond these, up to a height of 2,4 m above the deck	Zone 1
12	Areas on open deck over the cargo area where structures are restricting the natural ventilation and to the full breadth of the ship plus 3 m fore and aft of the forward-most and aft-most cargo tank bulkhead, up to a height of 2,4 m above the deck	Zone 1
13	Compartments for cargo hoses	Zone 1
14	Enclosed or semi-enclosed spaces in which pipes containing cargoes are located	Zone 1
15	Areas of 1,5 m surrounding a space of zone 1	Zone 2
16	Spaces 4 m beyond the cylinder and 4 m beyond the sphere defined in item 9	Zone 2
17	Fore peak ballast tank not adjacent to cargo tanks, when ballasted with the system serving ballast tanks in the cargo area according to Ch 7, Sec 4, [2.3.8]	Zone 2
18	Areas on open deck extending to the coamings fitted to keep any spills on deck and away from the accommodation and service area and 3 m beyond these up to a height of 2,4 m above the deck	Zone 2
19	Areas on open deck over the cargo area where unrestricted natural ventilation is guaranteed and to the full breadth of the ship plus 3 m fore and aft of the forward-most and aft-most cargo tank bulkhead, up to a height of 2,4 m above the deck surrounding open or semi-enclosed spaces of zone 1	Zone 2
20	Spaces forward of the open deck areas to which reference is made in 12 and 18, below the level of the main deck, and having an opening on to the main deck or at a level less than 0,5 m above the main deck, unless: <ul style="list-style-type: none"> the doors and all openings are in non-hazardous area; and the spaces are mechanically ventilated 	Zone 2

Section 6 Fire Protection

1 General

1.1 Application

1.1.1 Unless otherwise specified, the provisions of this Section apply to the ships having one of the following service notations:

- oil tanker
- oil tanker, flash point > 60°C
- oil tanker, asphalt carrier
- FLS tanker
- FLS tanker, flash point > 60°C.

1.2 Documents to be submitted

1.2.1 The documents listed in Ch 7, Sec 2, Tab 1 are to be submitted for approval in addition to those listed in Tab 1.

Table 1 : Documents to be submitted

No.	Description of the document (1)
1	General arrangement drawing
2	Specification of the fire integrity of bulkheads and decks
3	Specification of the instruments for measuring oxygen and flammable vapour concentrations
4	Diagram of the pressure water system within the cargo area
5	For the foam extinguishing system within the cargo area: <ul style="list-style-type: none"> • diagrammatic arrangement drawing • calculation note • foam agent specification • characteristics of foam monitors and hoses
6	For the fire-extinguishing system in cargo pump rooms: <ul style="list-style-type: none"> • general arrangement drawing • calculation note
7	For the inert gas installation: <ul style="list-style-type: none"> • single-wire diagram of the installation together with the main characteristics: capacity, pressure, temperature, oxygen content, water content, • list of the components with their characteristics: pipes, scrubber, blowers, non-return devices, valves, pumps, protective devices for over-pressure and vacuum, • drawing of arrangement of installation on board, • diagram of instrumentation, alarm and safeguard systems, • specification of oxygen analyser, recorder and portable instrumentation, • operational manual containing instructions relative to the operation of the inert gas system and to safety.
(1) Diagrams are also to include, where applicable, the (local and remote) control and monitoring systems and automation systems.	

2 General requirements

2.1 Sources of ignition

2.1.1 Dangerous zones or spaces are not to contain:

- internal combustion engines
- steam turbines and steam piping with a steam temperature in excess of 220°C
- other piping systems and heat exchangers with a fluid temperature in excess of 220°C
- any other source of ignition.

Note 1: Dangerous zones and spaces correspond to hazardous areas defined in Pt C, Ch 2, Sec 1, [3.25].

2.2 Electrical equipment

2.2.1 For the installation of electrical equipment, refer to Ch 7, Sec 5.

3 Fixed deck foam system

3.1 Application

3.1.1 Service notation oil tanker

Ships having the service notation **oil tanker** are to be provided with a fixed deck foam system complying with the provisions of [3.2] and [3.3] or with an equivalent fixed installation.

Note 1: To be considered equivalent, the system proposed in lieu of the deck foam system is to:

- be capable of extinguishing spill fires and also preclude ignition of spilled oil not yet ignited, and
- be capable of combating fires in ruptured tanks.

3.1.2 Service notation FLS tanker

Ships having the service notation **FLS tanker** are to be provided with a fixed deck foam system complying with [11.3] of the IBC Code. The type of foam to be used is specified in Ch 7, App 4, Tab 1. Where ordinary foam is considered suitable, foam fire-extinguishing systems complying with the provisions of [3.2] and [3.3] are acceptable.

3.1.3 Service notations oil tanker, flash point > 60°C or oil tanker, asphalt carrier

Ships having the service notations **oil tanker, flash point > 60°C** or **oil tanker, asphalt carrier** are to be provided with a fixed deck foam system complying with the provisions of [3.2] and [3.3] or with an equivalent fixed installation. However, such a system is not required in the case of ships of less than 2000 gross tonnage.

Note 1: For the definition of "equivalent installation", refer to [3.1.1].

3.2 System design

3.2.1 Principles

- a) The arrangements for providing foam are to be capable of delivering foam to the entire cargo tank deck area as well as into any cargo tank the deck of which has been ruptured.
- b) The deck foam system is to be capable of simple and rapid operation.
- c) Operation of a deck foam system at its required output shall permit the simultaneous use of the minimum required number of jets of water at the required pressure from the fire main. Where the deck foam system is supplied by a common line from the fire main, additional foam concentrate shall be provided for operation of two nozzles for the same period of time required for the foam system.

The simultaneous use of the minimum required jets of water shall be possible on deck over the full length of the ship, in the accommodation spaces, service spaces, control stations and machinery spaces.

- d) Foam from the fixed foam system is to be supplied by means of monitors and foam applicators.

Note 1: On tankers of less than 4000 tonnes deadweight, the Society may not require installation of monitors but only applicators.

- e) Applicators are to be provided to ensure flexibility of action during fire-fighting operations and to cover areas screened from the monitors.

3.2.2 Foam solution - Foam concentrate

- a) The rate of supply of foam solution is not to be less than the greatest of the following:

- 1) 0,6 l/min per square metre of cargo tanks deck area, where cargo tanks deck area means the maximum breadth of the ship multiplied by the total longitudinal extent of the cargo tank spaces,
- 2) 6 l/min per square metre of the horizontal sectional area of the single tank having the largest such area, or
- 3) 3 l/min per square metre of the area protected by the largest monitor, such area being entirely forward of the monitor, but in no case should the output of any monitor be less than 1,250 l/min.

- b) Sufficient foam concentrate shall be supplied to ensure at least 20 minutes of foam generation in tankers fitted with an inert gas installation or 30 minutes of foam generation in tankers not fitted with an inert gas installation or not required to use an inert gas system.

- c) The foam concentrate supplied on board shall be approved by the Society based on IMO Circular MSC.1/Circ.1312 for the cargoes intended to be carried. Type B foam concentrates shall be supplied for the protection of crude oil, petroleum products and non-polar solvent cargoes. Type A foam concentrates shall be supplied for polar solvent cargoes, as listed in the table of chapter 17 of the IBC Code. Only one type of foam concentrate shall be supplied, and it shall be effective for the maximum possible number of cargoes intended to be carried. For cargoes for which foam is not effective or is incompatible, additional arrangements to the satisfaction of the Society shall be provided.

- d) *Liquid cargoes with a flashpoint not exceeding 60°C for which a regular foam fire-fighting system is not effective shall comply with the following provisions:*
- 1) *The foam shall be of alcohol-resistant type;*
 - 2) *The type of foam concentrates for use in chemical tankers shall be approved by the Society based on IMO Circular MSC.1/Circ.1312; and*
 - 3) *The capacity and application rates of the foam extinguishing system shall comply with chapter 11 of the IBC Code, except that lower application rates may be accepted based on performance tests. For tankers fitted with inert gas systems, a quantity of foam concentrate sufficient for 20 min of foam generation may be accepted.*

3.2.3 Monitors and foam applicators

- a) *Prototype tests of the monitors and foam applicators shall be performed to ensure the foam expansion and drainage time of the foam produced does not differ more than 10 per cent of that determined in [3.2.2], item c). When medium expansion ratio foam (between 21 to 1 and 200 to 1 expansion ratio) is employed, the application rate of the foam and the capacity of a monitor installation shall be to the satisfaction of the Society. At least 50 per cent of the foam solution supply rate required shall be delivered from each monitor.*
- b) *The capacity of any applicator is to be not less than 400 l/min and the applicator throw in still air conditions is to be not less than 15 m.*

Note 1: Where, in pursuance of [3.2.1], the installation of monitors is not required on tankers of less 4000 tonnes deadweight, the capacity of each applicator is to be at least 25% of the foam solution supply rate required in [3.2.2], items a) 1) and a) 2).

3.3 Arrangement and installation

3.3.1 Monitors

- a) *The number and position of monitors are to be such as to comply with item a) of [3.2.1].*
- b) *The distance from the monitor to the farthest extremity of the protected area forward of that monitor is not to be more than 75 per cent of the monitor throw in still air conditions.*
- c) *A monitor and hose connection for a foam applicator shall be situated both port and starboard at the front of the poop or accommodation spaces facing the cargo tank deck. The monitors and hose connections shall be aft of any cargo tanks, but may be located in the cargo area above pump-rooms, cofferdams, ballast tanks, oil bunker tanks, and void spaces adjacent to cargo tanks if capable of protecting the deck below and aft of each other.*

Note 1: On tankers of less than 4000 tonnes deadweight a hose connection for a foam applicator is to be situated both port and starboard at the front of the poop or accommodation spaces facing the cargo tank deck.

3.3.2 Applicators

- a) *At least four foam applicators shall be provided on all tankers. The number and disposition of foam main outlets shall be such that foam from at least two applicators can be directed on to any part of the cargo tank deck area.*
- b) *Where the ship is provided with a stern or aft cargo loading or unloading arrangement, the deck foam system is to be so arranged as to permit the protection of the shore connection by at least two foam applicators.*

3.3.3 Isolation valves

Valves are to be provided in the foam main, and in the fire main when this is an integral part of the deck foam system, immediately forward of any monitor position to isolate damaged sections of those mains.

3.3.4 Main control station

The main control station for the system is to be suitably located outside the cargo area, adjacent to the accommodation spaces and readily accessible and operable in the event of fire in the areas protected.

4 Fire-extinguishing systems except deck foam system

4.1 Pressure water fire-extinguishing systems

4.1.1 *The pressure water fire-fighting systems provided on ships having the service notations **oil tanker, oil tanker, flash point > 60°C, oil tanker, asphalt carrier, FLS tanker or FLS tanker, flash point > 60°C** are subject to the provisions of Pt C, Ch 4, Sec 6, [1], except that:*

- a) *The capacity of the fire pumps is to be calculated without taking into account the reduction permitted in Ch 7, Sec 4, [2.2.2].*
- b) *Isolation valves are to be fitted in the fire main at poop front in a protected position and on the tank deck at intervals of not more than 40 m to preserve the integrity of the fire main system in the event of fire or explosion.*

4.1.2 *Attention is drawn to the provisions of item c) of [3.2.1].*

4.2 Fire-extinguishing systems for cargo pump rooms

4.2.1 Application

- a) Cargo pump rooms of ships having the service notations **oil tanker** or **FLS tanker** are to be provided with a fixed fire-extinguishing system complying with [4.2.2].
- b) Cargo pump rooms of ships having the service notations **oil tanker, flash point > 60°C** or **oil tanker, asphalt carrier** are to be provided with a fixed fire-extinguishing system complying with [4.2.2], except where the cargo is carried at a temperature below and not within 15°C of the flash point.

4.2.2 Design and arrangement of the fire-extinguishing system

- a) Where required by [4.2.1], each cargo pump-room is to be provided with one of the following fixed fire-extinguishing systems operated from a readily accessible position outside the pump-room. Cargo pump-rooms are to be provided with a system suitable for machinery spaces of category A.
 - 1) Carbon dioxide fire-extinguishing system complying with the provisions of Pt C, Ch 4, Sec 15, [4] and with the following:
 - the alarms giving audible warning of the release of fire-extinguishing medium are to be safe for use in a flammable cargo vapour/air mixture,
 - a notice is to be exhibited at the controls stating that due to the electrostatic ignition hazard, the system is to be used only for fire extinguishing and not for inerting purposes.
 - 2) A high-expansion foam system complying with the provisions of Pt C, Ch 4, Sec 15, [5.2], provided that the foam concentrate supply is suitable for extinguishing fires involving the cargoes carried.
 - 3) A fixed pressure water-spraying system complying with the provisions of Pt C, Ch 4, Sec 15, [6].
- b) Where the extinguishing medium used in the cargo pump-room system is also used in systems serving other spaces, the quantity of medium provided or its delivery rate need not be more than the maximum required for the largest compartment.

5 Inert gas systems

5.1 Application

5.1.1 Ships where an inert gas system is required

- a) Ships having the service notation **oil tanker** or **FLS tanker** and of 8 000 tonnes deadweight and upwards are to be fitted with an inert gas system complying with the provisions of this Article, or with equivalent systems or arrangements in accordance with [5.1.2].
- b) All tankers operating with a cargo tank cleaning procedure using crude oil washing are to be fitted with an inert gas system complying with the requirements of this Article.
- c) Such system is to be provided in every cargo tank and slop tank.
- d) Tankers required to be fitted with inert gas systems shall comply with the following provisions:
 - double hull spaces shall be fitted with suitable connections for the supply of inert gas. This includes all ballast tanks and void spaces of double hull and double bottom spaces adjacent to the cargo tanks, including the forepeak tank and any other tanks and spaces under the bulkhead deck adjacent to cargo tanks, except cargo pump-rooms and ballast pump-rooms
 - where hull spaces are connected to a permanently fitted inert gas distribution system, means shall be provided to prevent hydrocarbon gases from the cargo tanks entering the double hull spaces through the system; and
 - where such spaces are not permanently connected to an inert gas distribution system, appropriate means shall be provided to allow connection to the inert gas main.

5.1.2 Requirements for equivalent systems

- a) For ships having the service notations **oil tanker** or **FLS tanker** and of 8 000 tonnes deadweight and upwards but less than 20 000 tonnes deadweight, the Society may accept other equivalent arrangements in accordance with item a) of [5.1.1] and following item b)
- b) Equivalent systems or arrangements shall:
 - be capable of preventing dangerous accumulation of explosive mixtures in intact cargo tanks during normal service throughout the ballast voyage and necessary in-tank operations, and
 - be so designed as to minimize the risk of ignition from the generation of static electricity by the system itself.

5.1.3 Ships where an inert gas system is fitted but not required

Inert gas systems provided on ships where such systems are not required by [5.1.1] are to comply with the provisions of [5.4].

5.2 General requirements

5.2.1 The inert gas system is to comply with the applicable requirements of Pt C, Ch 4, Sec 15, [13].

5.2.2 Plans in diagrammatic form are to be submitted for appraisal and are to include the following:

- details and arrangement of inert gas generating plant including all control monitoring devices
- arrangement of piping system for distribution of the inert gas.

5.2.3 An automatic control capable of producing suitable inert gas under all service conditions is to be fitted.

5.3 Additional requirements for nitrogen generator systems

5.3.1 The following requirements apply where a nitrogen generator system is fitted on board as required by [5.1.1]. For the purpose, the inert gas is to be produced by separating air into its component gases by passing compressed air through a bundle of hollow fibres, semi-permeable membranes or adsorber materials.

5.3.2 In addition to the applicable requirements of Pt C, Ch 4, Sec 15, [13], the nitrogen generator system is to comply with Ch 7, Sec 4, [4.3.2] and Ch 7, Sec 4, [4.2.10].

5.3.3 A nitrogen generator is to consist of a feed air treatment system and any number of membrane or adsorber modules in parallel necessary to meet the requirements of Pt C, Ch 4, Sec 15, [13.2.1], item b) 4).

5.3.4 The nitrogen generator is to be capable of delivering high purity nitrogen in accordance with Pt C, Ch 4, Sec 15, [13.2.1], item b) 5). In addition to Pt C, Ch 4, Sec 15, [13.2.2], item d), the system is to be fitted with automatic means to discharge “off-spec” gas to the atmosphere during start-up and abnormal operation.

5.3.5 The system is to be provided with one or more compressors to generate enough positive pressure to be capable of delivering the total volume of gas required by Pt C, Ch 4, Sec 15, [13.2.1], item b). Where two compressors are provided, the total required capacity of the system is preferably to be divided equally between the two compressors, and in no case is one compressor to have a capacity less than 1/3 of the total capacity required.

5.3.6 The feed air treatment system fitted to remove free water, particles and traces of oil from the compressed air as required by Pt C, Ch 4, Sec 15, [13.4.2], item b), is also to preserve the specification temperature.

5.3.7 The oxygen-enriched air from the nitrogen generator and the nitrogen-product enriched gas from the protective devices of the nitrogen receiver are to be discharged to a safe location on the open deck.

Note 1: “safe location” needs to address the two types of discharges separately:

- oxygen-enriched air from the nitrogen generator - safe locations on the open deck are:
 - outside of hazardous area;
 - not within 3m of areas traversed by personnel; and
 - not within 6m of air intakes for machinery (engines and boilers) and all ventilation inlets
- nitrogen-product enriched gas from the protective devices of the nitrogen receiver - safe locations on the open deck are:
 - not within 3m of areas traversed by personnel; and
 - not within 6m of air intakes for machinery (engines and boilers) and all ventilation inlets/outlets.

5.3.8 In order to permit maintenance, means of isolation are to be fitted between the generator and the receiver.

5.4 Nitrogen/inert gas systems fitted for purposes other than inerting required by [5.1.1]

5.4.1 Nitrogen/inert gas systems fitted on oil tankers of less than 8 000 tonnes deadweight and for which an inert gas system is not required by [5.1.1] are to comply with the following requirements.

5.4.2 Requirements of:

- Pt C, Ch 4, Sec 15, [13.2.2], item b)
- Pt C, Ch 4, Sec 15, [13.2.2], item d)
- Pt C, Ch 4, Sec 15, [13.2.4], item b)
- Pt C, Ch 4, Sec 15, [13.2.4], item c)
- Pt C, Ch 4, Sec 15, [13.2.4], item e) 1) regarding oxygen content and power supply to the indicating devices
- Pt C, Ch 4, Sec 15, [13.2.4], item e) 4)
- Pt C, Ch 4, Sec 15, [13.4.2] and
- Pt C, Ch 4, Sec 15, [13.4.3],

apply to the systems.

5.4.3 The requirements of [5.3] apply except requirements [5.3.1] to [5.3.3] and [5.3.5]

5.4.4 The two non-return devices as required by Pt C, Ch 4, Sec 15, [13.2.3], item a) 1) are to be fitted in the inert gas main. The non-return devices are to comply with Pt C, Ch 4, Sec 15, [13.2.3], item a) 2) and Pt C, Ch 4, Sec 15, [13.2.3], item a) 3); however, where the connections to the cargo tanks, to the hold spaces or to cargo piping are not permanent, the non-return devices required by Pt C, Ch 4, Sec 15, [13.2.3], item a) 1) may be substituted by two non-return valves.

6 Fixed hydrocarbon gas detection systems

6.1 Engineering specifications

6.1.1 General

- a) The fixed hydrocarbon gas detection system is to be designed, constructed and tested to the satisfaction of the Society based on IMO Circular MSC.1/Circ.1370.
- b) The system is to be comprised of a central unit for gas measurement and analysis and gas sampling pipes in all ballast tanks and void spaces of double-hull and double-bottom spaces adjacent to the cargo tanks, including the forepeak tank and any other tanks and spaces under the bulkhead deck adjacent to cargo tanks.
- c) The system may be integrated with the cargo pump-room gas detection system, provided that the spaces referred to in item b) above are sampled at the rate required in [6.1.2], item c) 1). Continuous sampling from other locations may also be considered provided the sampling rate is complied with.

6.1.2 Component requirements

a) Gas sampling lines

- 1) Common sampling lines to the detection equipment shall not be fitted, except the lines serving each pair of sampling points as required in item 3) below.
- 2) The materials of construction and the dimensions of gas sampling lines are to be such as to prevent restriction. Where non-metallic materials are used, they shall be electrically conductive. The gas sampling lines shall not be made of aluminium.
- 3) The configuration of gas sampling lines is to be adapted to the design and size of each space. Except as provided in items 4) and 5) below, the sampling system shall allow for a minimum of two hydrocarbon gas sampling points, one located on the lower and one on the upper part where sampling is required. When required, the upper gas sampling point shall not be located lower than 1 m from the tank top. The position of the lower located gas sampling point shall be above the height of the girder of bottom shell plating but at least 0,5 m from the bottom of the tank and it shall be provided with means to be closed when clogged. In positioning the fixed sampling points, due regard should also be given to the density of vapours of the oil products intended to be transported and the dilution from space purging or ventilation.
- 4) For ships with deadweight of less than 50000 tonnes, the Society may allow the installation of one sampling location for each tank for practical and/or operational reasons.
- 5) For ballast tanks in the double-bottom, ballast tanks not intended to be partially filled and void spaces, the upper gas sampling point is not required.
- 6) Means are to be provided to prevent gas sampling lines from clogging when tanks are ballasted by using compressed air flushing to clean the line after switching from ballast to cargo loaded mode. The system shall have an alarm to indicate if the gas sampling lines are clogged.

b) Gas analysis unit

The gas analysis unit shall be located in a safe space and may be located in areas outside the ship's cargo area; for example, in the cargo control room and/or navigation bridge in addition to the hydraulic room when mounted on the forward bulkhead, provided the following requirements are observed:

- 1) Sampling lines shall not run through gas safe spaces, except where permitted under item 5) below;
- 2) The hydrocarbon gas sampling pipes shall be equipped with flame arresters. Sample hydrocarbon gas is to be led to the atmosphere with outlets arranged in a safe location, not close to a source of ignitions and not close to the accommodation area air intakes;
- 3) A manual isolating valve, which shall be easily accessible for operation and maintenance, shall be fitted in each of the sampling lines at the bulkhead on the gas safe side;
- 4) The hydrocarbon gas detection equipment including sample piping, sample pumps, solenoids, analysing units etc., shall be located in a reasonably gas-tight cabinet (e.g., fully enclosed steel cabinet with a door with gaskets) which is to be monitored by its own sampling point. At a gas concentration above 30% of the lower flammable limit inside the steel enclosure the entire gas analysing unit is to be automatically shut down; and
- 5) Where the enclosure cannot be arranged directly on the bulkhead, sample pipes shall be of steel or other equivalent material and without detachable connections, except for the connection points for isolating valves at the bulkhead and analysing unit, and are to be routed on their shortest ways.

c) Gas detection equipment

- 1) The gas detection equipment is to be designed to sample and analyse from each sampling line of each protected space, sequentially at intervals not exceeding 30 min.
- 2) Means are to be provided to enable measurements with portable instruments, in case the fixed system is out of order or for system calibration. In case the system is out of order, procedures shall be in place to continue to monitor the atmosphere with portable instruments and to record the measurement results.
- 3) Audible and visual alarms are to be initiated in the cargo control room, navigation bridge and at the analysing unit when the vapour concentration in a given space reaches a pre-set value, which shall not be higher than the equivalent of 30% of the lower flammable limit.
- 4) The gas detection equipment shall be so designed that it may readily be tested and calibrated.

7 Gas measurement and detection

7.1 Provisions applicable to all ships

7.1.1 All ships are to be provided with at least two portable gas detectors capable of measuring flammable vapour concentrations in air (%LEL) and at least two portable oxygen analysers. Alternatively, at least two gas detectors, each capable of measuring both oxygen and flammable vapour concentrations in air (%LEL), are to be provided.

Note 1: The number of portable detection instruments required above is considered equivalent to one portable instrument for measuring flammable vapour concentration, one portable instrument for measuring oxygen and sufficient spares.

7.1.2 The gas detectors required in [7.1.1] are to be type approved by the Society.

7.2 Additional provisions for ships having the service notation oil tanker or FLS tanker

7.2.1 Gas measurement

Ships having the service notation **oil tanker** or **FLS tanker** are to comply with the following provisions:

- a) *Suitable means are to be provided for the calibration of portable instruments for measuring oxygen and/or flammable vapour concentrations.*
- b) *Suitable portable instruments for measuring oxygen and flammable vapour concentrations in double hull spaces and double-bottom spaces are to be provided. In selecting these instruments, due attention is to be given to their use in combination with the fixed gas sampling line systems referred to in item c).*
- c) *Where the atmosphere in double hull spaces cannot be reliably measured using flexible gas sampling hoses, such spaces are to be fitted with permanent gas sampling lines. The configuration of gas sampling lines is to be adapted to the design of such spaces.*
- d) *The materials of construction and the dimensions of gas sampling lines are to be such as to prevent restriction. Where plastic materials are used, they are to be electrically conductive.*

7.2.2 Fixed hydrocarbon gas detection systems

Ships having the service notation **oil tanker** or **FLS tanker** are to comply with the following provisions:

- a) *In addition to the requirements in [7.2.1], ships having the service notation **oil tanker** or **FLS tanker** of 20000 tonnes deadweight and above, are to be provided with a fixed hydrocarbon gas detection system complying with [6] for measuring hydrocarbon gas concentrations in all ballast tanks and void spaces of double-hull and double-bottom spaces adjacent to the cargo tanks, including the forepeak tank and any other tanks and spaces under the bulkhead deck adjacent to cargo tanks.*

Note 1: The term "cargo tanks" in the phrase "spaces adjacent to the cargo tanks" includes slop tanks except those arranged for the storage of oily water only.

The term "spaces" in the phrase "spaces under the bulkhead deck adjacent to cargo tanks" includes dry compartments such as ballast pump-rooms and bow thruster rooms and any tanks such as freshwater tanks, but excludes fuel oil tanks.

The term "adjacent" in the phrase "adjacent to the cargo tanks" includes ballast tanks, void spaces, other tanks or compartments located below the bulkhead deck located adjacent to cargo tanks and includes any spaces or tanks located below the bulkhead deck which form a cruciform (corner to corner) contact with the cargo tanks.

- b) *Ships having the service notation **oil tanker** or **FLS tanker** provided with constant operative inerting systems for such spaces need not be equipped with fixed hydrocarbon gas detection equipment.*
- c) *Notwithstanding the above, cargo pump-rooms subject to the provisions of Ch 7, Sec 4, [3.5] need not comply with the present requirement.*

7.3 Additional provisions for ships fitted with an inert gas system

7.3.1 In addition to the provisions of [7.1], for ships fitted with inert gas systems, at least two portable gas detectors are to be capable of measuring concentrations of flammable vapours in inerted atmosphere.

Gas detectors are to be capable of measuring any gas content from 0 to 100% in volume.

7.4 Provisions for installation of gas analysing units

7.4.1 The following provisions apply to gas analysing units of the sampling type located outside gas dangerous zones.

7.4.2 Gas analysing units with non-explosion proof measuring equipment may be located in areas outside cargo areas, e.g. in cargo control room, navigation bridge or engine room when mounted on the forward bulkhead provided the following requirements are observed:

- a) Sampling lines are not to run through gas safe spaces, except where permitted under e).
- b) The gas sampling pipes are to be equipped with flame arresters. Sample gas is to be led to the atmosphere with outlets arranged in a safe location.
- c) Bulkhead penetrations of sample pipes between safe and dangerous areas are to be of approved type and have same fire integrity as the division penetrated. A manual isolating valve is to be fitted in each of the sampling lines at the bulkhead on the gas safe side.
- d) The gas detection equipment including sample piping, sample pumps, solenoids, analysing units etc. is to be located in a reasonably gas tight (e.g. a fully enclosed steel cabinet with a gasketed door) which is to be monitored by its own sampling point. At gas concentrations above 30% LFL inside the steel cabinet the entire gas analysing unit is to be automatically shut down.
- e) Where the cabinet cannot be arranged directly on the bulkhead, sample pipes are to be of steel or other equivalent material and without detachable connections, except for the connection points for isolating valves at the bulkhead and analysing units, and are to be routed on their shortest ways.

Appendix 1 Devices to Prevent the Passage of Flame into the Cargo Tanks

1 General

1.1 Application

1.1.1 This Appendix reproduces the text of MSC Circ. 677. It is intended to cover the design, testing, location and maintenance of "devices to prevent the passage of flame into cargo tanks" (hereafter called "devices") of ships having the service notations **oil tanker** or **combination carrier** carrying crude oil, petroleum products having a flash point of 60°C (closed cup test) or less and a Reid vapour pressure below atmospheric pressure, and other liquids with similar fire hazard. It also applies to ships having the service notation **FLS tanker** carrying flammable products having such a flash point.

1.1.2 Ships having the service notations **oil tanker**, **combination carrier** or **FLS tanker** and fitted with an inert gas system in accordance with Ch 7, Sec 6, [5] are to be fitted with devices which comply with this Appendix, except that the tests specified in [4.2.3] and [4.3.3] are not required. Such devices are only to be fitted at openings unless they are tested in accordance with [4.4].

1.1.3 This Appendix is intended for devices protecting cargo tanks containing crude oil, petroleum products and flammable chemicals. In the case of the carriage of chemicals, the test media referred to in [4] can be used. However, devices for chemical tankers dedicated to the carriage of products with MESH less than 0,9 mm are to be tested with appropriate media.

Note 1: For MESH (Maximum Experimental Safe Gap) reference should be made to IEC 60079-1.

1.1.4 Devices are to be tested and located in accordance with this Appendix.

1.1.5 Devices are installed to protect:

- a) openings designed to relieve pressure or vacuum caused by thermal variations (see Ch 7, Sec 4, [4.2.2], item a));
- b) openings designed to relieve pressure or vacuum during cargo loading, ballasting or discharging (see Ch 7, Sec 4, [4.2.2], item b));
- c) outlets designed for gas-freeing (see Ch 7, Sec 4, [4.3.3]).

1.1.6 Devices are not to be capable of being bypassed or blocked open unless they are tested in the bypassed or blocked open position in accordance with [4].

1.1.7 This Appendix does not include consideration of sources of ignition such as lightning discharges, since insufficient information is available to formulate equipment recommendations. All cargo handling, tank cleaning and ballasting operations are to be suspended on the approach of an electrical storm.

1.1.8 This Appendix is not intended to deal with the possibility of the passage of flame from one cargo tank to another on tankers with common venting systems.

1.1.9 When outlet openings of gas-freeing systems on tankers not fitted with inert gas systems are required to be protected with devices, they are to comply with this Appendix except that the tests specified in [4.2.3] and [4.3.3] are not required.

1.1.10 Certain of the tests prescribed in [4] of this Appendix are potentially hazardous, but no attempt is made in this Appendix to specify safety requirements for these tests.

1.2 Definitions

1.2.1 Premise

For the purpose of this Appendix, the definitions given in the following paragraphs are applicable.

1.2.2 Flame arrester

A flame arrester is a device to prevent the passage of flame in accordance with a specified performance standard. Its flame arresting element is based on the principle of quenching.

1.2.3 Flame screen

A flame screen is a device utilising wire mesh to prevent the passage of unconfined flames in accordance with a specified performance standard.

1.2.4 Flame speed

The flame speed is the speed at which a flame propagates along a pipe or other system.

1.2.5 Flashback

Flashback is the transmission of a flame through a device.

1.2.6 High velocity vent

A high velocity vent is a device to prevent the passage of flame consisting of a mechanical valve which adjusts the opening available for flow in accordance with the pressure at the inlet of the valve in such a way that the efflux velocity cannot be less than 30 m/s.

1.2.7 Pressure/vacuum valve

A pressure/vacuum valve is a device designed to maintain pressure and vacuum in a closed container within preset limits.

Note 1: Pressure/vacuum valves are devices to prevent the passage of flame when designed and tested in accordance with this Appendix.

1.3 Instruction manual

1.3.1 The manufacturer is to supply a copy of the instruction manual, which is to be kept on board the tanker and which is to include:

- a) installation instructions
- b) operating instructions
- c) maintenance requirements, including cleaning (see [2.3.3])
- d) a copy of the laboratory report referred to in [4.6]
- e) flow test data, including flow rates under both positive and negative pressures, operating sensitivity, flow resistance and velocity.

2 Design of the devices

2.1 Principles

2.1.1 Depending on their service and location, devices are required to protect against the propagation of:

- a) moving flames, and/or
- b) stationary flames from pre-mixed gases after ignition of gases resulting from any cause.

2.1.2 When flammable gases from outlets ignite, the following four situations may occur:

- a) at low gas velocities the flame may:
 - 1) flashback, or
 - 2) stabilise itself as if the outlet were a burner.
- b) at high gas velocities, the flame may:
 - 1) burn at a distance above the outlet, or
 - 2) be blown out.

2.1.3 In order to prevent the passage of flame into a cargo tank, devices are to be capable of performing one or more of the following functions:

- a) permitting the gas to pass through passages without flashback and without ignition of the gases on the protected side when the device is subjected to heating for a specified period
- b) maintaining an efflux velocity in excess of the flame speed for the gas irrespective of the geometric configuration of the device and without the ignition of gases on the protected side, when the device is subjected to heating for a specified period; and
- c) preventing an influx of flame when conditions of vacuum occur within the cargo tanks.

2.2 Mechanical design

2.2.1 The casing or housing of devices is to meet similar standards of strength, heat resistance and corrosion resistance as the pipe to which it is attached.

2.2.2 The design of devices is to allow for ease of inspection and removal of internal elements for replacement, cleaning or repair.

2.2.3 All flat joints of the housing are to be machined true and are to provide an adequate metal-to-metal contact.

2.2.4 Flame arrester elements are to fit in the housing in such a way that flame cannot pass between the element and the housing.

2.2.5 Resilient seals may be installed only if their design is such that if the seals are partially or completely damaged or burned, the device is still capable of effectively preventing the passage of flame.

2.2.6 Devices are to allow for efficient drainage of moisture without impairing their efficiency to prevent the passage of flame.

2.2.7 The casing, flame arrester element and gasket materials are to be capable of withstanding the highest pressure and temperature to which the device may be exposed under both normal and specified fire test conditions.

2.2.8 End-of-line devices are to be so constructed as to direct the efflux vertically upwards.

2.2.9 Fastenings essential to the operation of the device, i.e. screws, etc., are to be protected against loosening.

2.2.10 Means are to be provided to check that any valve lifts easily without remaining in the open position.

2.2.11 Devices in which the flame arresting effect is achieved by the valve function and which are not equipped with flame arrester elements (e.g. high velocity valves) are to have a width of the contact area of the valve seat of at least 5 mm.

2.2.12 Devices are to be resistant to corrosion in accordance with [4.5.1].

2.2.13 Elements, gaskets and seals are to be of material resistant to both seawater and the cargoes carried.

2.2.14 The casing of the housing is to be capable of passing a hydrostatic pressure test, as required in [4.5.2].

2.2.15 In-line devices are to be able to withstand without damage or permanent deformation the internal pressure resulting from detonation when tested in accordance with [4.4].

2.2.16 A flame arrester element is to be designed to ensure quality control of manufacture to meet the characteristics of the prototype tested, in accordance with this Appendix.

2.3 Performance

2.3.1 Devices are to be tested in accordance with [4.5] and thereafter shown to meet the test requirements of [4.2] to [4.4], as appropriate.

Note 1: End-of-line devices which are intended for exclusive use at openings of inerted cargo tanks need not be tested against endurance burning as specified in [4.2.3].

Note 2: Where end-of-line devices are fitted with cowls, weather hoods and deflectors, etc., these attachments are to be fitted for the tests described in [4.2].

Note 3: When venting to atmosphere is not performed through an end-of-line device according to Note 2, or a detonation flame arrester according to [3.2.2], the in-line device is to be specifically tested with the inclusion of all pipes, tees, bends, cowls, weather hoods, etc., which may be fitted between the device and atmosphere. The testing is to consist of the flashback test in [4.2.2] and, if for the given installation it is possible for a stationary flame to rest on the device, the testing is also to include the endurance burning test in [4.2.3].

2.3.2 Performance characteristics such as the flow rates under both positive and negative pressure, operating sensitivity, flow resistance and velocity are to be demonstrated by appropriate tests.

2.3.3 Devices are to be designed and constructed to minimise the effect of fouling under normal operating conditions. Instructions on how to determine when cleaning is required and the method of cleaning are to be provided for each device in the manufacturer's instruction manual.

2.3.4 Devices are to be capable of operating in freezing conditions and if any device is provided with heating arrangements so that its surface temperature exceeds 85°C, then it is to be tested at the highest operating temperature.

2.3.5 Devices based upon maintaining a minimum velocity are to be capable of opening in such a way that a velocity of 30 m/s is immediately initiated, maintaining an efflux velocity of at least 30 m/s at all flow rates and, when the gas flow is interrupted, closing in such a way that this minimum velocity is maintained until the valve is fully closed.

2.3.6 In the case of high velocity vents, the possibility of inadvertent detrimental hammering leading to damage and/or failure is to be considered, with a view to eliminating it.

Note 1: Hammering is intended to mean a rapid full stroke opening/ closing, not foreseen by the manufacturer during normal operations.

2.4 Flame screens

2.4.1 Flame screens are to be:

- a) designed in such a manner that they cannot be inserted improperly in the opening
- b) securely fitted in openings so that flames cannot circumvent the screen
- c) able to meet the requirements of this Appendix. For flame screens fitted at vacuum inlets through which vapours cannot be vented, the test specified in [4.2.3] need not be complied with
- d) protected against mechanical damage.

2.5 Marking of devices

2.5.1 Each device is to be permanently marked, or have a permanently fixed tag made of stainless steel or other corrosion-resistant material, to indicate:

- a) the manufacturer's name or trade mark
- b) the style, type, model or other manufacturer's designation for the device
- c) the size of the outlet for which the device is approved
- d) the approved location for installation, including maximum or minimum length of pipe, if any, between the device and the atmosphere
- e) the direction of flow through the device
- f) the test laboratory and report number, and
- g) compliance with the requirements of this Appendix.

3 Sizing, location and installation of devices

3.1 Sizing of devices

3.1.1 To determine the size of devices to avoid inadmissible pressure or vacuum in cargo tanks during loading or discharging, calculations of pressure losses are to be carried out.

The following parameters are to be taken into account:

- a) loading/discharge rates
- b) gas evolution
- c) pressure loss through devices, taking into account the resistance coefficient
- d) pressure loss in the vent piping system
- e) pressure at which the vent opens if a high velocity valve is used
- f) density of the saturated vapour/air mixture
- g) possible fouling of a flame arrester; 70% of its rated performance is to be used in the pressure drop calculation of the installation.

3.2 Location and installation of devices

3.2.1 General

- a) Devices are to be located at the vent outlets to atmosphere unless tested and approved for in-line installation.
- b) Devices for in-line installation may not be fitted at the outlets to atmosphere unless they have also been tested and approved for that position.

3.2.2 Detonation flame arresters

Where detonation flame arresters are installed as in-line devices venting to atmosphere, they are to be located at a sufficient distance from the open end of the pipeline so as to preclude the possibility of a stationary flame resting on the arrester.

3.2.3 Access to the devices

Means are to be provided to enable personnel to reach devices situated more than 2 m above deck to facilitate maintenance, repair and inspection.

4 Type test procedures

4.1 Principles

4.1.1 Tests are to be conducted by a laboratory acceptable to the Society.

4.1.2 Each size of each model is to be submitted for type testing. However, for flame arresters, testing may be limited to the smallest and the largest sizes and one additional size in between to be chosen by the Society. Devices are to have the same dimensions and most unfavourable clearances expected in the production model. If a test device is modified during the test program, the testing is to be restarted.

4.1.3 Tests described in this Article using gasoline vapours (a non-leaded petroleum distillate consisting essentially of aliphatic hydrocarbon compounds with a boiling range approximating $65^{\circ}\text{C} \pm 75^{\circ}\text{C}$), technical hexane vapours or technical propane, as appropriate, are suitable for all devices protecting tanks containing a flammable atmosphere of the cargoes referred to in Ch 7, Sec 1, [1.1.3]. This does not preclude the use of gasoline vapours or technical hexane vapours for all tests referred to in this Article.

4.1.4 After the relevant tests, the device is not to show mechanical damage that affects its original performance.

4.1.5 Before the tests the following equipment, as appropriate, is to be properly calibrated:

- a) gas concentration meters
- b) thermometers
- c) flow meters
- d) pressure meters, and
- e) time recording devices.

4.1.6 The following characteristics are to be recorded, as appropriate, throughout the tests:

- a) concentration of fuel in the gas mixture
- b) temperature of the test gas mixture at inflow of the device, and
- c) flow rates of the test gas mixtures when applicable.

4.1.7 Flame passage is to be observed by recording, e.g. temperature, pressure, or light emission, by suitable sensors on the protected side of the device; alternatively, flame passage may be recorded on video tape.

4.2 Test procedure for flame arresters located at openings to the atmosphere

4.2.1 Test rig

The test rig is to consist of an apparatus producing an explosive mixture, a small tank with a diaphragm, a flanged prototype of the flame arrester, a plastic bag and a firing source in three positions (see Fig 1). Other test rigs may be used, provided the tests referred to in this Article are carried out to the satisfaction of the Society.

Note 1: The dimensions of the plastic bag are dependent on those of the flame arrester, but for flame arresters normally used on tankers the plastic bag may have a circumference of 2 m, a length of 2,5 m and a wall thickness of 0,05 mm.

Note 2: In order to avoid remnants of the plastic bag from falling back on to the device being tested after ignition of the fuel/air mixture, it may be useful to mount a coarse wire frame across the device within the plastic bag. The frame is to be so constructed as not to interfere with the test result.

Figure 1 : Test rig for flashback test

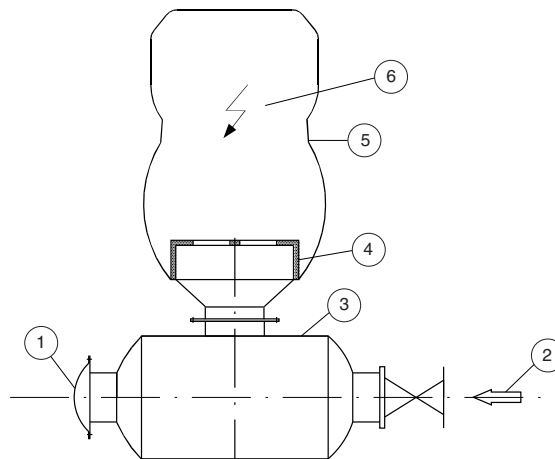

- (1): Plastic bursting diaphragm
- (2): Explosive mixture inlet
- (3): Tank
- (4): Flame arresting device
- (5): Plastic bag
- (6): Ignition source

4.2.2 Flashback test

A flashback test is to be carried out as follows:

- a) The tank, flame arrester assembly and the plastic bag (see [4.2.1]) enveloping the prototype flame arrester are to be filled so that this volume contains the most easily ignitable propane/air mixture (see IEC 60079-1). The concentration of the mixture is to be verified by appropriate testing of the gas composition in the plastic bag. Where devices referred to in [2.3.1], Note 3 are tested, the plastic bag is to be fitted at the outlet to atmosphere. Three ignition sources are to be installed along the axis of the bag, one close to the flame arrester, another as far away as possible therefrom, and the third at the mid-point between these two. These three sources are to be fired in succession, twice in each of the three positions. The temperature of the test gas is to be within the range of 15°C to 40°C.
- b) If a flashback occurs, the tank diaphragm will burst and this will be audible and visible to the operator by the emission of a flame. Flame, heat and pressure sensors may be used as an alternative to a bursting diaphragm.

4.2.3 Endurance burning test

An endurance burning test is to be carried out, in addition to the flashback test, for flame arresters at outlets where flows of explosive vapour are foreseeable:

- a) The test rig as referred to in [4.2.1] may be used, without the plastic bag. The flame arrester is to be so installed that the mixture emission is vertical. In this position the mixture is to be ignited. Where devices referred to in [2.3.1] Note 3, are tested, the flame arrester is to be so installed as to reflect its final orientation.
- b) Endurance burning is to be achieved by using the most easily ignitable gasoline vapour/air mixture or the most easily ignitable technical hexane vapour/air mixture with the aid of a continuously operated pilot flame or a continuously operated spark igniter at the outlet. The test gas is to be introduced upstream of the tank shown in Fig 1. Maintaining the concentration of the mixture as specified above, by varying the flow rate, the flame arrester is to be heated until the highest obtainable temperature on the cargo tank side of the arrester is reached. Temperatures are to be measured, for example, at the protected side of the flame quenching matrix of the arrester (or at the seat of the valve in the case of testing high velocity vents according to [4.3]). The highest obtainable temperature may be considered to have been reached when the rate of rise of temperature does not exceed 0,5°C per minute over a ten-minute period. This temperature is to be maintained for a period of ten minutes, after which the flow is to be stopped and the conditions observed. The temperature of the test gas is to be within the range of 15°C to 40°C.

If no temperature rise occurs at all, the arrester is to be inspected for a more adequate position of the temperature sensor, taking account of the visually registered position of the stabilised flame during the first test sequence. Positions which require the drilling of small holes into fixed parts of the arrester are to be taken into account. If all this is not successful, the temperature sensor is to be affixed at the unprotected side of the arrester in a position near to the stabilised flame.

If difficulties arise in establishing stationary temperature conditions (at elevated temperatures), the following criteria is to apply: using the flow rate which produced the maximum temperature during the foregoing test sequence, endurance burning is to be continued for a period of two hours from the time the above-mentioned flow rate has been established. After that period the flow is to be stopped and the conditions observed. Flashback is not to occur during this test.

4.2.4 Pressure/vacuum valve integrated to a flame arresting device

When a pressure/vacuum valve is integrated to a flame arresting device, the flashback test is to be performed with the pressure/vacuum valve blocked open. If there are no additional flame quenching elements integrated in a pressure valve, this valve is to be considered and tested as a high velocity vent valve according to [4.3].

4.3 Test procedures for high velocity vents

4.3.1 Test rig

The test rig is to be capable of producing the required volume flow rate. In Fig 2 and Fig 3 drawings of suitable test rigs are shown. Other test rigs may be used provided the tests are performed to the satisfaction of the Society.

4.3.2 Flow condition test

A flow condition test is to be carried out with high velocity vents using compressed air or gas at agreed flow rates. The following are to be recorded:

- a) the flow rate; where air or a gas other than vapours of cargoes with which the vent is to be used is employed in the test, the flow rates achieved are to be corrected to reflect the vapour density of such cargoes
- b) the pressure before the vent opens; the pressure in the test tank on which the device is located is not to rise at a rate greater than 0,01 N/mm²/min
- c) the pressure at which the vent opens
- d) the pressure at which the vent closes
- e) the efflux velocity at the outlet which is not to be less than 30 m/s at any time when the valve is open.

4.3.3 Fire safety tests

The following fire safety tests are to be conducted while adhering to [2.3.6] using a mixture of gasoline vapour and air or technical hexane vapour and air, which produces the most easily ignitable mixture at the point of ignition. This mixture is to be ignited with the aid of a permanent pilot flame or a spark igniter at the outlet.

- a) Flashback tests in which propane may be used instead of gasoline or hexane are to be carried out with the vent in the upright position and then inclined at 10° from the vertical. For some vent designs further tests with the vent inclined in more than one direction may be necessary. In each of these tests the flow is to be reduced until the vent closes and the flame is extinguished, and each is to be carried out at least 50 times. The vacuum side of combined valves is to be tested in accordance with [4.2.2] with the vacuum valve maintained in the open position for the duration of this test, in order to verify the efficiency of the device which is to be fitted.
- b) An endurance burning test, as described in [4.2.3], is to be carried out. Following this test, the main flame is to be extinguished and then, with the pilot flame burning or the spark igniter discharging, small quantities of the most easily ignitable mixture are to be allowed to escape for a period of ten minutes maintaining a pressure below the valve of 90% of the valve opening setting, during which time flashback is not to occur. For the purpose of this test the soft seals or seats are to be removed.

Figure 2 : Schematic plan of the test plant for high velocity valves (endurance burning test only)

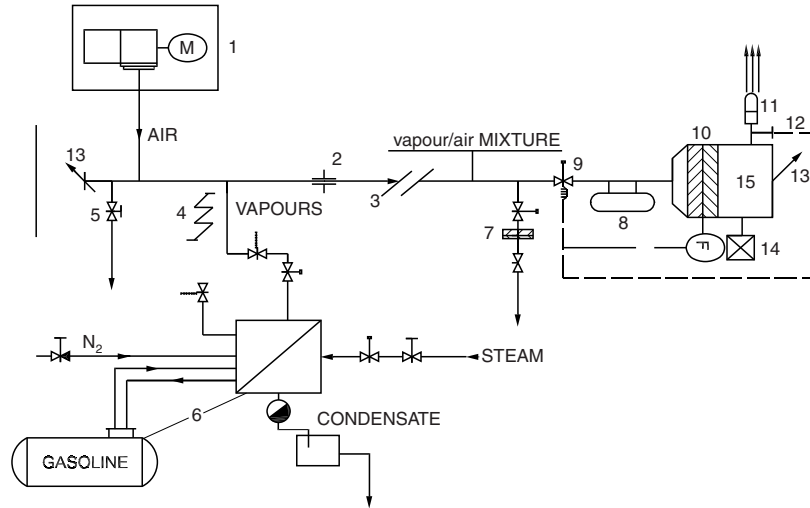

- (1): Fan with variable speed
- (2): Volume rate indicator
- (3): Pipe (diameter=500 mm, length=30 m)
- (4): Heated vapour pipe
- (5): Air bypass
- (6): Evaporator and gasoline storage tank
- (7): Vapour/air mixture bypass
- (8): Extinguishing agents
- (9): Automatic control and quick action stop valve
- (10): Explosion arresting crimped ribbon with temperature sensors for the safety of the test rig
- (11): High velocity valve to be tested
- (12): Flame detector
- (13): Bursting diaphragm
- (14): Concentration indicator
- (15): Tank

Figure 3 : Test rig for high velocity vents

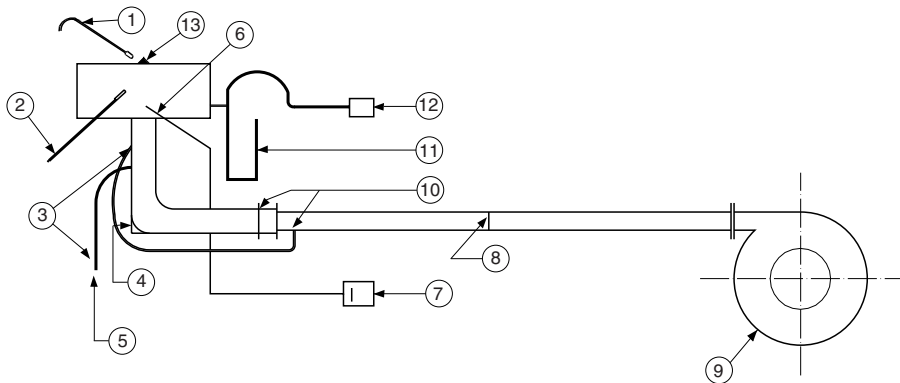

- (1): Primary igniter
- (2): Secondary igniter
- (3): Cocks
- (4): Explosion door
- (5): Gas supply
- (6): Flashback detector
- (7): Chart recorder
- (8): Flow meter
- (9): Fan
- (10): Spade blank and bypass line for low rates
- (11): Pressure gauge
- (12): Gas analyser
- (13): High velocity vent to be tested

4.4 Test rig and test procedures for detonation flame arresters located in-line

4.4.1 A flame arrester is to be installed at one end of a pipe of suitable length and of the same diameter as the flange of the flame arrester. On the opposed flange a pipe of a length corresponding to 10 pipe diameters is to be affixed and closed by a plastic bag or diaphragm. The pipe is to be filled with the most easily ignitable mixture of propane and air, which is then to be ignited. The velocity of the flame near the flame arrester is to be measured and is to have the same value as that for stable detonations.

Note 1: The dimensions of the plastic bag are to be at least 4 m circumference, 4 m length and a material wall thickness of 0,05 mm.

Figure 4 : Test rig for arresters located in-line

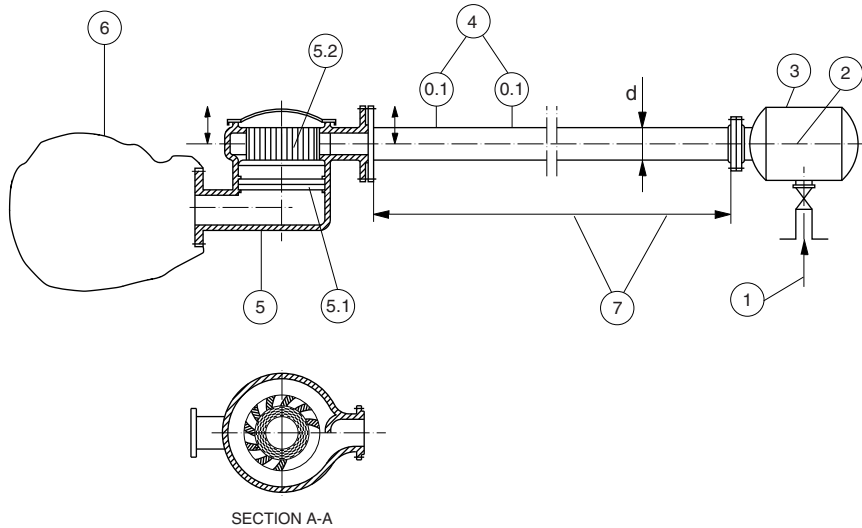

- (1): Explosive mixture inlet
- (2): Ignition source; ignition within non-streaming mixture
- (3): Tank
- (4): Measuring system for flame speed of a stable detonation
- (5): Flame arrester located in-line; (5.1): Flame arrester element; (5.2): Shock wave absorber
- (6): Plastic bag
- (7): $l/d = 100$

4.4.2 Three detonation tests are to be conducted, no flashback is to occur through the device and no part of the flame arrester is to be damaged or show permanent deformation.

4.4.3 Other test rigs may be used provided the tests are carried out to the satisfaction of the Society. A drawing of the test rig is shown in Fig 4.

4.5 Operational test procedure

4.5.1 Corrosion test

A corrosion test is to be carried out. In this test a complete device, including a section of the pipe to which it is fitted, is to be exposed to a 5% sodium chloride solution spray at a temperature of 25°C for a period of 240 hours, and allowed to dry for 48 hours. An equivalent test may be conducted to the satisfaction of the Society. Following this test, all movable parts are to operate properly and there are to be no corrosion deposits which cannot be washed off.

4.5.2 Hydraulic pressure test

A hydraulic pressure test is to be carried out in the casing or housing of a sample device, in accordance with [2.2.15].

4.6 Laboratory report

4.6.1 The laboratory report is to include:

- a) detailed drawings of the device
- b) types of tests conducted; where in-line devices are tested, this information is to include the maximum pressures and velocities observed in the test
- c) specific advice on approved attachments
- d) types of cargo for which the device is approved
- e) drawings of the test rig
- f) in the case of high velocity vents, the pressures at which the device opens and closes and the efflux velocity, and
- g) all the information marked on the device in [2.5].

Appendix 2 Design of Crude Oil Washing Systems

1 General

1.1 Application

1.1.1 This Appendix reproduces the text of IMO Resolution A.446. It applies to ships having the notation **oil tanker** in the conditions stated in Ch 7, Sec 4, [4.6.1].

1.2 Definitions

1.2.1 Arrival ballast

For the purpose of this Appendix, "arrival ballast" means clean ballast as defined in Ch 7, Sec 1, [1.2.5].

1.2.2 Departure ballast

For the purpose of this Appendix, "departure ballast" means ballast other than arrival ballast.

1.3 Operations and Equipment Manual

1.3.1 The Operations and Equipment Manual of the crude oil washing system is to be submitted to the Society for information. It is to contain at least the following information:

- a) line drawing of the crude oil washing system showing the respective position of pumps, lines and washing machines which relate to the crude oil washing system
- b) a description of the system and a listing of procedures for checking that equipment is working properly during crude oil washing operations. This is to include a listing of the system and equipment parameters to be monitored, such as line pressure, oxygen level, machine revolutions, duration of cycles, etc. The established values for these parameters are to be included. The results of the tests carried out in accordance with [3.3] and the values of all parameters monitored during such tests are also to be included.
- c) other information referred to in [2.1.8], [2.2.2], [2.3.2], [2.3.5], [2.4.3] and [3.3.1].

2 Design and installation

2.1 Piping

2.1.1 The crude oil washing pipes and all valves incorporated in the supply piping system are to be of steel or other equivalent material, of adequate strength having regard to the pressure to which they may be subjected, and properly jointed and supported.

Note 1: Grey cast iron may be permitted in the supply system for crude oil washing systems when complying with nationally approved standards.

2.1.2 The crude oil washing system is to consist of permanent pipework and is to be independent of the fire mains and of any system other than for tank washing except that sections of the ship's cargo system may be incorporated into the crude oil washing system provided that they meet the requirements applicable to crude oil pipework. Notwithstanding the above requirements, in combination carriers the following arrangements may be allowed:

- a) the removal of the equipment, if necessary, when carrying cargoes other than crude oil, provided that, when reinstated, the system is as originally fitted and tested for oil-tightness
- b) the use of flexible hose pipes to connect the crude oil washing system to tank washing machines if it is necessary to locate these machines in a cargo tank hatch cover. Such flexible hose pipes are to be provided with flanged connections, manufactured and tested in accordance with standards acceptable to the Society, and consistent with the duties the hoses are required to perform. The length of these hoses is not to be greater than necessary to connect the tank washing machines to an adjacent point just outside the hatch coaming. The hoses are to be removed to a suitably prepared and protected stowage location when not in use.

2.1.3 Provisions are to be made to prevent overpressure in the tank washing supply piping. Any relief device fitted to prevent overpressure is to discharge into the suction side of the supply pump. Alternative methods to the satisfaction of the Society may be accepted provided an equivalent degree of safety and environmental protection is provided.

Note 1: Where the system is served only by centrifugal pumps so designed that the pressure derived cannot exceed that for which the piping is designed, a temperature sensing device located in the pump casing is required to stop the pump in the case of overheating.

2.1.4 Where hydrant valves are fitted for water washing purposes on tank washing lines, all such valves are to be of adequate strength and provisions are to be made for such connections to be blanked off by blank flanges when washing lines may contain crude oil. Alternatively, hydrant valves are to be isolated from the crude oil washing system by spade blanks.

2.1.5 All connections for pressure gauges or other instrumentation are to be provided with isolating valves adjacent to the lines unless the fitting is of the sealed type.

2.1.6 No part of the crude oil washing system is to enter machinery spaces. Where the tank washing system is fitted with a steam heater for use when water washing, the heater is to be located outside machinery spaces and effectively isolated during crude oil washing by double shut-off valves or by clearly identifiable blanks.

2.1.7 Where combined crude oil-water washing supply piping is provided, the piping is to be so designed that it can be drained so far as practicable of crude oil, before water washing is commenced, into designated spaces. These spaces may be the slop tank or other cargo spaces.

2.1.8 The piping system is to be of such diameter that the greatest number of tank cleaning machines required, as specified in the Operations and Equipment Manual, can be operated simultaneously at the designed pressure and throughput. The arrangement of the piping is to be such that the required number of tank cleaning machines for each cargo compartment as specified in the Operations and Equipment Manual can be operated simultaneously.

2.1.9 The crude oil washing supply piping is to be anchored (firmly attached) to the ship's structure at appropriate locations, and means are to be provided to permit freedom of movement elsewhere to accommodate thermal expansion and flexing of the ship. The anchoring is to be such that any hydraulic shock can be absorbed without undue movement of the supply piping. The anchors are normally to be situated at the ends furthest from the entry of the crude oil supply to the supply piping. If tank washing machines are used to anchor the ends of branch pipes then special arrangements are necessary to anchor these sections when the machines are removed for any reason.

2.2 Tank washing machines

2.2.1 Tank washing machines for crude oil washing are to be permanently mounted and of a design acceptable to the Society.

2.2.2 The performance characteristic of a tank washing machine is governed by nozzle diameter, working pressure and the movement pattern and timing. Each tank cleaning machine fitted is to have a characteristic such that the sections of the cargo tank covered by that machine will be effectively cleaned within the time specified in the Operations and Equipment Manual.

2.2.3 Tank washing machines are to be mounted in each cargo tank and the method of support is to be to the satisfaction of the Society. Where a machine is positioned well below the deck level to cater for protuberances in the tank, consideration may need to be given to additional support for the machine and its supply piping.

2.2.4 Each machine is to be capable of being isolated by means of stop valves in the supply line. If a deck mounted tank washing machine is removed for any reason, provision is to be made to blank off the oil supply line to the machine for the period the machine is removed. Similarly, provision is to be made to close the tank opening with a plate or equivalent means.

Note 1: Where more than one submerged machine is connected to the same supply line, a single isolating stop valve in the supply line may be acceptable provided the rotation of the submerged machine can be verified in accordance with [2.2.10]

2.2.5 The number and location of tank washing machines are to be to the satisfaction of the Society.

2.2.6 The location of the machines is dependent upon the characteristics detailed in [2.2.2] and upon the configuration of the internal structure of the tank.

2.2.7 The number and location of the machines in each cargo tank are to be such that all horizontal and vertical areas are washed by direct impingement or effectively by deflection or splashing of the impinging jet. In assessing an acceptable degree of jet deflection and splashing, particular attention is to be paid to the washing of upward facing horizontal areas and the following parameters are to be used:

- a) For horizontal areas of a tank bottom and the upper surfaces of a tank's stringers and other large primary structural members, the total area shielded from direct impingement by deck or bottom transverses, main girders, stringers or similar large primary structural members is not to exceed 10 per cent of the horizontal area of the tank bottom, the upper surface of stringers, and other large primary structural members.
- b) For vertical areas of the sides of a tank, the total area of the tank's sides shielded from direct impingement by deck or bottom transverses, main girders, stringers or similar large primary structural members is not to exceed 15 per cent of the total area of the tank's sides.

In some installations, it may be necessary to consider the fitting of more than one type of tank washing machine in order to effect adequate coverage.

Note 1: With regard to the application of this requirement, a slop tank is considered as a cargo tank.

2.2.8 At the design stage the following minimum procedures are to be used to determine the area of the tank surface covered by direct impingement:

- a) Using suitable structural plans, lines are set out from the tips of each machine to those parts of the tank within the range of the jets.
- b) Where the configuration of the tanks is considered by the Society to be complicated, a pinpoint of light simulating the tip of the tank washing machine in a scale model of the tank is to be used.

2.2.9 The design of the deck mounted tank washing machines is to be such that means are provided external to cargo tanks which, when crude oil washing is in progress, would indicate the rotation and arc of the movement of the machine. Where the deck mounted machine is of the non-programmable, dual nozzle type, alternative methods to the satisfaction of the Society may be accepted provided an equivalent degree of verification is attained.

2.2.10 Where submerged machines are required, they are to be non-programmable and, in order to comply with the requirements of [2.2.7], it is to be possible to verify their rotation by one of the following methods:

- a) by indicators external to the tanks
- b) by checking the characteristic sound pattern of the machine, in which case the operation of the machine is to be verified towards the end of each wash cycle. Where two or more submerged machines are installed on the same supply line, valves are to be provided and arranged so that the operation of each machine can be verified independently of other machines on the same supply line.
- c) by gas freeing the tank and checking the operation of the machine with water during ballast voyages.

2.3 Pumps

2.3.1 Pumps supplying crude oil to tank cleaning machines are to be either the cargo pumps or pumps specifically provided for the purpose.

2.3.2 The capacity of the pumps is to be sufficient to provide the necessary throughput at the required pressure for the maximum number of tank cleaning machines required to be operated simultaneously as specified in the Operations and Equipment Manual. In addition to the above requirement, if an eductor system is fitted for tank stripping, the pumps are to be capable of supplying the eductor driving fluid to meet the provisions of [2.4.2].

2.3.3 The capacity of the pumps is to be such that the requirements of [2.3.2] can be met with any one pump inoperative. The pumping and piping arrangements are to be such that the crude oil washing system can be effectively operated with any one pump out of use.

2.3.4 The carriage of more than one grade of cargo is not to prevent crude oil washing of tanks.

2.3.5 To permit crude oil washing to be effectively carried out where the back pressure presented by the shore terminal is below the pressure required for crude oil washing, provision is to be made such that an adequate pressure to the washing machines can be maintained in accordance with [2.3.2]. This requirement is to be met with any one cargo pump out of action. The minimum supply pressure required for crude oil washing is to be specified in the Operations and Equipment Manual. Should this minimum supply pressure not be obtainable, crude oil washing operations are not to be carried out.

2.4 Stripping system

2.4.1 The design of the system for stripping crude oil from the bottom of every cargo tank is to be to the satisfaction of the Society.

2.4.2 The design and capacity of the tank stripping system are to be such that the bottom of the tank being cleaned is kept free of accumulations of oil and sediment towards completion of the tank washing process.

2.4.3 The stripping system is to be at least 1,25 times the total throughput of all the tank cleaning machines to be operated simultaneously when washing the bottom of the cargo tanks as described in the ship's Operations and Equipment Manual.

2.4.4 Means such as level gauges, hand dipping and stripping system performance gauges as referred to in [2.4.8] are to be provided for checking that the bottom of every cargo tank is dry after crude oil washing. Suitable arrangements for hand dipping are to be provided at the aftermost portion of a cargo tank and in three other suitable locations unless other approved means are fitted for efficiently ascertaining that the bottom of every cargo tank is dry. For the purpose of this paragraph, the cargo tank bottom is to be considered "dry" if there is no more than a small quantity of oil near the stripping suction with no accumulation of oil elsewhere in the tank.

2.4.5 Means are to be provided to drain all cargo pumps and lines at the completion of cargo discharge, where necessary, by connection to a stripping device. The line and pump draining is to be capable of being discharged both to a cargo tank and ashore. For discharge ashore, a special small diameter line is to be provided for this purpose and connected outboard of the ship's manifold valve. The cross-sectional area of this line is not to exceed 10 per cent of that of a main cargo discharge line.

Note 1: In crude oil tankers having individual cargo pumps in each tank, each pump having an individual piping system, dispensation from the required special small diameter line may be granted in cases where the combined amount of oil left in the tank after stripping and the volume

of oil in the piping system from the manifold to the tank is less than 0,00085 times the volume of the cargo tank. The above consideration is also to apply if a deepwell cargo pump system is provided with an evacuating system for retained oil.

2.4.6 The means for stripping oil from cargo tanks are to be a positive displacement pump, self-priming centrifugal pump or eductor or other methods to the satisfaction of the Society. Where a stripping line is connected to a number of tanks, means are to be provided for isolating each tank not being stripped at that particular time.

2.4.7 The carriage of more than one grade of cargo is not to prevent crude oil washing of tanks.

2.4.8 Equipment is to be provided for monitoring the efficiency of the stripping system. All such equipment is to have remote read out facilities in the cargo control room or in some other safe and convenient place easily accessible to the officer in charge of cargo and crude oil washing operations. Where a stripping pump is provided, the monitoring equipment is to include either a flow indicator, or a stroke counter or revolution counter as appropriate, and pressure gauges at the inlet and discharge connections of the pump or equivalent. Where eductors are provided, the monitoring equipment is to include pressure gauges at the driving fluid intake and at the discharge and a pressure/vacuum gauge at the suction intake.

2.4.9 The internal structure of the tank is to be such that drainage of oil to the tank suction of the stripping system is adequate to meet the requirements of [2.4.2] and [2.4.4].

2.5 Ballast lines

2.5.1 Where a separate ballast water system for ballasting cargo tanks is not provided, the arrangement is to be such that the cargo pump, manifolds and pipes used for ballasting can be safely and effectively drained of oil before ballasting.

3 Inspection and testing

3.1 Initial survey

3.1.1 The initial survey required in Ch 7, Sec 4, [6.3.2] is to include a complete inspection of the crude oil washing equipment and arrangements and, except for the cases specified in [3.3.3], an examination of the tanks after they have been crude oil washed and the additional checks specified in [3.3.1] and [3.3.2] to ensure that the washing system efficiency is in accordance with this Appendix.

3.2 Piping

3.2.1 The piping system is to be tested to one and a half times the working pressure after it has been installed on the ship.

3.3 Tank washing machines

3.3.1 To confirm the cleanliness of the tank and to verify the design in respect of the number and location of the tank washing machines, a visual inspection is to be made by entry to the tanks after a crude oil wash but prior to any water rinse which may be specified in the Operations and Equipment Manual. The bottom of the tank to be inspected may, however, be flushed with water and stripped in order to remove any wedge of liquid crude oil remaining on the tank bottom before gas freeing for entry. This inspection is to ensure that the tank is essentially free of oil clingage and deposits. If the flushing procedure is adopted, a similar but unflushed tank is to be used for the test specified in [3.3.2].

3.3.2 To verify the effectiveness of the stripping and drainage arrangements, a measurement is to be made of the amount of oil floating on top of the departure ballast. The ratio of the volume of oil on top of the departure ballast water to the volume of tanks that contain this water is not to exceed 0,00085. This test is to be carried out after crude oil washing and stripping in a tank similar in all relevant respects to the tank examined in accordance with [3.3.1] above, which has not been subjected to a water rinse or to the intervening water flushing permissible in [3.3.1] above.

3.3.3 When the Society is satisfied that ships are similar in all relevant respects, the provisions of [3.3.1] and [3.3.2] need only be applied to one such ship. Furthermore, where a ship has a series of tanks that are similar in all relevant respects then, for that series of tanks, the requirements of [3.3.1] need only be applied to one tank of that series.

3.4 Stripping system

3.4.1 Care is to be taken that both longitudinal and transverse drainage are satisfactory. Drainage is to be verified during the inspection required by [3.3].

Appendix 3 Lists of Oils

1 Application

1.1 Scope of the lists of oils

1.1.1 The lists set out in this Appendix include the oils the carriage in bulk of which is covered by the service notations **oil tanker** or **oil tanker, flash point > 60°C** or **oil tanker, asphalt carrier**, under the provisions of Ch 7, Sec 1, [1.1.3].

2 Lists of products

2.1 List of oils

2.1.1 The list given in Tab 1 is reproduced from Appendix 1 of the MARPOL 73/78 Convention, except that naphtha solvent is, in the opinion of the Society, to be considered as a chemical to which Part D, Chapter 8 applies. This list is not necessarily comprehensive.

Table 1 : List of oils

Asphalt solutions <ul style="list-style-type: none"> • Blending stocks • Roofers flux • Straight run residue 	Gasoline blending stock <ul style="list-style-type: none"> • Alkylates - fuel • Reformates • Polymer - fuel
Oils <ul style="list-style-type: none"> • Clarified • Crude oil • Mixtures containing crude oil • Diesel oil • Fuel oil n° 4 • Fuel oil n° 5 • Fuel oil n° 6 • Residual fuel oil • Road oil • Transformer oil • Aromatic oil (excluding vegetable oil) • Lubricating oils and blending stocks • Mineral oil • Spindle oil • Turbine oil 	Gasolines <ul style="list-style-type: none"> • Casinghead (natural) • Automotive • Aviation • Straight run • Fuel oil n° 1 (kerosene) • Fuel oil n° 1-D • Fuel oil n° 2 • Fuel oil n° 2-D
Distillates <ul style="list-style-type: none"> • Straight run • Flashed feed stocks 	Jet fuels <ul style="list-style-type: none"> • JP-1 (kerosene) • JP-3 • JP-4 • JP-5 (kerosene, heavy) • Turbo fuel • Kerosene • Mineral spirit
Gas oil <ul style="list-style-type: none"> • Cracked 	Naphtha <ul style="list-style-type: none"> • Petroleum • Heartcut distillate oil

Appendix 4 List of Products for which Part D, Chapter 8 and IBC Code do not Apply

1 Application

1.1 Scope of the list

1.1.1 The list set out in this Appendix includes all products to which Part D, Chapter 8 and IBC Code do not apply. Such products are allowed to be carried by ships having the service notation **FLS tanker** or, where their flash point is above 60°C, also by ships having the service notation **FLS tanker flash point > 60 °C**.

Where indicated in the list, some products are also allowed to be carried by ships having the service notation **tanker**.

1.2 Safety and pollution hazards

1.2.1

- The following are products which have been reviewed for their safety and pollution hazards and determined not to present hazards to such an extent as to warrant application of the IBC Code and Part D, Chapter 8.*
- Although the products listed in this Appendix fall outside the scope of the IBC Code and Part D, Chapter 8, some safety precautions are needed for their safe transportation. Relevant requirements are summarized in Tab 1.*
- Some liquid substances are identified as falling into pollution category Z and, therefore, subject to certain requirements of MARPOL Annex II.*
- Liquid mixtures which are assessed or provisionally assessed under Regulation 6.3 of MARPOL Annex II as falling into pollution category Z or OS, and which do not present safety hazards, may be carried under the appropriate entry in this Appendix for "Noxious or Non-Noxious liquid substances, not otherwise specified (n.o.s.)".*
- The liquid substances identified as falling into pollution category OS are not subject to any requirements of MARPOL Annex II in particular in respect of:
 - the discharge of bilge or ballast water or other residues or mixtures containing only such substances
 - the discharge into the sea of clean ballast or segregated ballast.

2 List of products for which Part D, Chapter 8 and IBC Code do not apply

2.1

2.1.1 The list of products for which Part D, Chapter 8 and IBC Code do not apply is given in Tab 1. The relevant symbols and notations used in Tab 1 are given in Tab 2.

Table 1 : List of easy chemicals

Product name	Pollution category	Electrical equipment temperature class	Electrical equipment apparatus group	Flash-point (°C)	Fire protection	Service notation
(a)	(b)	(c)	(d)	(e)	(f)	(g)
Acetone	Z	T1	IIA	-18	A	FLS
Alcoholic beverages, not otherwise specified	Z	–	–	20 to 60 (1)	A	FLS
Apple juice	OS	–	–	NF	–	T
n-Butyl alcohol	Z	T2	IIA	29	A	FLS
sec-Butyl alcohol	Z	T2	IIA	24	A	FLS
Calcium carbonate slurry	OS	–	–	NF	–	T
Clay slurry	OS	–	–	NF	–	T
Coal slurry	OS	–	–	NF	–	T
Ethyl alcohol	Z	T2	IIB	13	A	FLS
Glucose solution	OS	–	–	NF	–	T
Glycerol ethoxylated	OS	–	–	>60	–	FLS>60
Hydrogenated starch hydrolysate	OS	–	–	NF	–	T

Product name	Pollution category	Electrical equipment temperature class	Electrical equipment apparatus group	Flash-point (°C)	Fire protection	Service notation
(a)	(b)	(c)	(d)	(e)	(f)	(g)
Isopropyl alcohol	Z	T2	IIA	22	A	FLS
Kaolin slurry	OS	–	–	NF	–	T
Lecithin	OS	–	–	NF	–	T
Maltitol solution	OS	–	–	NF	–	T
Microsilica slurry	OS	–	–	NF	–	T
Molasses	OS	–	–	>60	–	FLS>60
Noxious liquid, n.o.s. (trade name ..., contains ...) Cat. Z	Z	–	–	<60	A	FLS
Non noxious liquid, n.o.s. (trade name ..., contains ...) Cat. OS	OS	–	–	<60	A	FLS
Orange juice (concentrated)	OS	–	–	NF	–	T
Orange juice (not concentrated)	OS	–	–	NF	–	T
Potassium chloride solution (less than 26%)	OS	–	–	NF	–	T
Propylene glycol	OS	T2	–	>60	–	FLS>60
Sodium acetate solutions	Z	–	–	NF	–	T
Sodium bicarbonate solutions (less than 10%)	OS	–	–	NF	–	T
Sorbitol solution	OS	–	–	>60	–	FLS>60
Sulphonated polyacrylate solution	Z	–	–	<60	A	FLS
Tetraethyl silicate monomer/oligomer (20% in ethanol)	Z	T2	IIB	<60	A	FLS
Triethylene glycol	OS	T2	–	>60	–	FLS>60
Vegetable protein solution (hydrolysed)	OS	–	–	NF	–	T
Water	OS	–	–	NF	–	T
(1) Composition dependent						

Table 2 : Symbols and notations used in the list of easy chemicals

Items	Column	Comments
Product name	(a)	Gives the alphabetical name of the products
Pollution category	(b)	The letter Z refers to the pollution category Z as defined in MARPOL Annex II. The symbol OS means that the product was evaluated and found to fall outside the pollution categories X, Y and Z defined in MARPOL Annex II
Electrical equipment temperature class	(c)	The symbols T1 to T6 refer to the electrical equipment temperature classes defined in IEC Publication 60079-20-1:2010
Electrical equipment apparatus group	(d)	The symbols IIA, IIB and IIC refer to the electrical equipment apparatus groups defined in IEC Publication 60079-20-1:2010
Flash point	(e)	NF: non-flammable product
Fire protection	(f)	The letters A, B, C and D refer to the following fire-extinguishing media determined to be effective for certain products: A : Alcohol-resistant foam (or multi-purpose foam) B : Regular foam, encompasses all foams that are not of an alcohol-resistant type, including fluoro-protein and aqueous-film-forming foam (AFFF) C : Water spray D : Dry chemical (powder)
Service notation	(g)	The symbols FLS, FLS>60 and T are defined as follows: FLS : Means that the product is allowed to be carried by a ship having the service notation FLS tanker FLS>60 : Means that the product is allowed to be carried by a ship having the service notation FLS tanker, flash point > 60°C T : Means that the product is allowed to be carried by a ship having the service notation tanker

Appendix 5 Accidental Oil Outflow Performance

Symbols

- d_s : Load line draught, equal to the vertical distance, in m, from the moulded baseline at mid-length to the waterline corresponding to the summer freeboard to be assigned to the ship. Calculations pertaining to this regulation are to be based on draught d_s , notwithstanding assigned draughts that may exceed d_s , such as the tropical loadline
- d_B : Vertical distance, in metres, from the moulded baseline at mid-length to the waterline corresponding to 30% of the depth D_s
- B_s : Greatest moulded breadth of the ship, in metres, at or below the deepest load line d_s
- B_B : Greatest moulded breadth of the ship, in metres, at or below the waterline d_B
- D_s : Moulded depth, in metres, measured at mid-length to the upper deck at side
- ρ_s : Density of sea water, to be taken as 1025 kg/m³
- ρ_n : Nominal density of cargo oil, in kg/m³, to be taken equal to:
 $\rho_n = 1000 (DWT)/C$
- C : Total volume of cargo oil, in m³, at 98% tank filling.

1 General

1.1 Purpose

1.1.1 The purpose of the present Appendix is to provide a method for the calculation of the accidental oil outflow performance referred to in Ch 7, Sec 2, [3.4.1].

1.2 Application

1.2.1 The requirements of the present Appendix apply only to ships having one of the following notations:

- oil tanker
- oil tanker, flash point > 60°C
- oil tanker, asphalt carrier.

2 Accidental oil outflow performance

2.1 Mean oil outflow parameter

2.1.1 To provide adequate protection against oil pollution in the event of collision or stranding the following is to be complied with:

a) For oil tankers of 5000 tonnes deadweight (DWT) and above, the mean oil outflow parameter O_M is to be as follows:

- for $C = 200000$ m³:
 $O_M = 0,015$
- for $200000 \text{ m}^3 < C < 400000 \text{ m}^3$:
 $O_M = 0,012 + (0,003/200000) (400000 - C)$
- for $C = 400000$ m³:
 $O_M = 0,012$

For combination carriers between 5000 tonnes deadweight (DWT) and 200000 m³ capacity, the mean oil outflow parameter O_M may be applied, provided calculations are submitted to the satisfaction of the Society, demonstrating that after accounting for its increased structural strength, the combination carrier has at least equivalent oil outflow performance to a standard double hull tanker of the same size having a $O_M = 0,015$.

- for $C = 100000$ m³:
 $O_M = 0,021$
- for $100000 \text{ m}^3 < C < 200000 \text{ m}^3$:
 $O_M = 0,015 + (0,006/100000) (200000 - C)$

b) For oil tankers of less than 5000 tonnes deadweight (DWT):

The length of each cargo tank is not to exceed 10 m or one of the following values, whichever is the greater:

- where no longitudinal bulkhead is provided inside the cargo tanks:
(0,5 $b_i/B + 0,1$) L without exceeding 0,2 L
- where centreline longitudinal bulkhead is provided inside the cargo tanks:
(0,25 $b_i/B + 0,15$) L
- where two or more longitudinal bulkheads are provided inside the cargo tanks:
as defined in Tab 1.

Table 1 : Length of each cargo tank for oil tankers of less than 5000 tonnes deadweight (DWT)

Wing cargo tanks	Centre cargo tanks		
0,2 L	$b_i/B \geq 0,2 L$	$b_i/B < 0,2 L$	
	0,2 L	no centreline longitudinal bulkhead is provided	a centreline longitudinal bulkhead is provided
		(0,5 $b_i/B + 0,1$) L	(0,25 $b_i/B + 0,15$) L
b_i : Minimum distance from the ship's side to the outer longitudinal bulkhead of the tank in question measured inboard at right angles to the centreline at the level corresponding to the assigned summer freeboard.			

2.2 Calculation

2.2.1 Assumptions

The cargo block length extends between the forward and aft extremities of all tanks arranged for the carriage of cargo oil, including slop tanks.

Where this regulation refers to cargo tanks, it is to be understood to include all cargo tanks, slop tanks and fuel tanks located within the cargo block length.

The ship is to be assumed loaded to the load line draught d_s without trim or heel.

All cargo oil tanks is to be assumed loaded to 98% of their volumetric capacity.

For the purposes of these outflow calculations, the permeability of each space within the cargo block, including cargo tanks, ballast tanks and other non-oil spaces is to be taken as 0,99, unless proven otherwise.

Suction wells may be neglected in the determination of tank location provided that such wells are as small as practicable and the distance between the well bottom and bottom shell plating is not less than 0,5h, where h is equal to B/15 or 2,0 m, whichever is the lesser, without being taken less than 1,0 m.

2.2.2 Combination of oil outflow parameters

The mean oil outflow is to be calculated independently for side damage and for bottom damage and then combined into the non-dimensional oil outflow parameter O_M , as follows:

$$O_M = (0,4 O_{MS} + 0,6 O_{MB})/C$$

where:

O_{MS} : Outflow for side damage, in m^3

O_{MB} : Outflow for bottom damage, in m^3 .

For bottom damage, independent calculations for mean outflow is to be done for 0 m and minus 2,5 m tide conditions, and then combined as follows:

$$O_{MB} = 0,7 O_{MB(0)} + 0,3 O_{MB(2,5)}$$

where:

$O_{MB(0)}$: Outflow for 0 m tide condition

$O_{MB(2,5)}$: Outflow for minus 2,5 m tide condition, in m^3 .

2.2.3 Mean outflow

a) The mean outflow, in m^3 , for side damage O_{MS} is to be calculated as follows:

$$O_{MS} = C_3 \sum (P_{S(i)} O_{S(i)})$$

where:

i : Represents each cargo tank under consideration

n : Total number of cargo tanks

$P_{S(i)}$: Probability of penetrating cargo tank i from side damage, calculated in accordance with [2.2.4]

$O_{S(i)}$: Outflow, in m^3 , from side damage to cargo tank i, which is assumed equal to the total volume in cargo tank i at 98% filling

- C_3 :
- for ships having two longitudinal bulkheads inside the cargo tanks, provided these bulkheads are continuous over the cargo block and $P_{S(i)}$ is developed in accordance with this regulation:
 $C_3 = 0,77$
 - for all other ships:
 $C_3 = 1,00$

b) The mean outflow for bottom damage is to be calculated for each tidal condition as follows:

$$O_{MB(0)} = \sum(P_{B(i)} O_{B(i)} C_{DB(i)})$$

where:

i : Represents each cargo tank under consideration

n : Total number of cargo tanks

$P_{B(i)}$: Probability of penetrating cargo tank i from bottom damage calculated in accordance with [2.2.5]

$O_{B(i)}$: Outflow from cargo tank i , in m^3 as defined in item c)

$C_{DB(i)}$: Factor to account for oil capture as defined in item d)

$$O_{MB(2,5)} = \sum(P_{B(i)} O_{B(i)} C_{DB(i)})$$

where:

$O_{B(i)}$: Outflow from cargo tank i , in m^3 , after tidal change.

c) The oil outflow $O_{B(i)}$ for each cargo oil tank is to be calculated based on pressure-balance principles, in accordance with the following assumptions:

- the ship is to be assumed stranded with zero trim and heel, with the stranded draught prior to tidal change equal to the load line draught d_s

- the cargo level after damage is to be calculated as follows:

$$h_c = ((d_s + t_c - Z_l) \rho_s - (1000 p) / g) / \rho_n$$

where:

h_c : Height of the cargo oil above Z_l , in m

t_c : Tidal change, in m. Reductions in tide shall be expressed as negative values

Z_l : Height of the lowest point in the cargo tank above baseline, in m

p : If an inert gas system is fitted, the normal overpressure, in kPa, to be taken as not less than 5 kPa.

If an inert gas system is not fitted, the overpressure may be taken as 0

- for cargo tanks bounded by the bottom shell, unless proven otherwise, oil outflow $O_{B(i)}$ is to be taken not less than 1% of the total volume of cargo oil loaded in cargo tank i , to account for initial exchange losses and dynamic effects due to current and waves.

d) In the case of bottom damage, a portion from the outflow from a cargo tank may be captured by non-oil compartments. This effect is approximated by application of the factor $C_{DB(i)}$ for each tank, which is to be taken as follows:

- for cargo tanks bounded from below by non-oil compartments:

$$C_{DB(i)} = 0,6$$

- for cargo tanks bounded by the bottom shell:

$$C_{DB(i)} = 1,0$$

2.2.4 Probability of breaching a compartment from side damage

The probability P_s of breaching a compartment from side damage is to be calculated as follows:

$$P_s = P_{SL} P_{SV} P_{ST}$$

where:

P_{SL} : Probability the damage extends into the longitudinal zone bounded by X_a and X_f

$$P_{SL} = 1 - P_{Sf} - P_{Sa}$$

P_{SV} : Probability the damage extends into the vertical zone bounded by Z_l and Z_u

$$P_{SV} = 1 - P_{Su} - P_{S1}$$

P_{ST} : Probability the damage extends transversely beyond the boundary defined by y

$$P_{ST} = 1 - P_{Sy}$$

P_{Sar} , P_{Sfr} , P_{S1} and P_{Su} are to be determined by linear interpolation from Tab 2 of probabilities for side damage provided in Tab 2 where:

P_{Sa} : Probability the damage lies entirely aft of location X_a / L

P_{Sf} : Probability the damage lies entirely forward of location X_f / L

P_{S1} : Probability the damage lies entirely below the tank

P_{Su} : Probability the damage lies entirely above the tank.

P_{Sy} , the probability the damage lies entirely outboard of the tank, is to be determined as follows:

- for $y / B_s = 0,05$:
 $P_{Sy} = (24,96 - 199,6 y / B_s) (y / B_s)$
- for $0,05 < y / B_s < 0,10$:
 $P_{Sy} = 0,749 + (5 - 44,4 (y / B_s - 0,05)) (y / B_s - 0,05)$
- for $y / B_s = 0,10$:
 $P_{Sy} = 0,888 + 0,56 (y / B_s - 0,1)$

P_{Sy} is not to be taken greater than 1.

Compartment boundaries X_a , X_f , Z_l , Z_u and y are to be developed as follows:

- X_a : Longitudinal distance from the aft terminal of L to the aftmost point on the compartment being considered, in m
- X_f : Longitudinal distance from the aft terminal of L to the foremost point on the compartment being considered, in m
- Z_l : Vertical distance from the moulded baseline to the lowest point on the compartment being considered, in m
- Z_u : Vertical distance from the moulded baseline to the highest point on the compartment being considered, in m
 Z_u is not to be taken greater than D_s
- y : Minimum horizontal distance measured at right angles to the centreline between the compartment under consideration and the side shell, in m.

Note 1: For symmetrical tank arrangements, damages are considered for one side of the ship only, in which case all "y" dimensions are to be measured from that same side.

For asymmetrical arrangements refer to the Explanatory Notes on matters related to the accidental oil outflow performance, adopted by the IMO by resolution MEPC.122(52).

Table 2 : Probabilities for side damage

X_a/L	P_{Sa}	X_f/L	P_{Sf}	Z_l/D_s	P_{Sl}	Z_u/D_s	P_{Su}
0,00	0,000	0,00	0,967	0,00	0,000	0,00	0,968
0,05	0,023	0,05	0,917	0,05	0,000	0,05	0,952
0,10	0,068	0,10	0,867	0,10	0,001	0,10	0,931
0,15	0,117	0,15	0,817	0,15	0,003	0,15	0,905
0,20	0,167	0,20	0,767	0,20	0,007	0,20	0,873
0,25	0,217	0,25	0,717	0,25	0,013	0,25	0,836
0,30	0,267	0,30	0,667	0,30	0,021	0,30	0,789
0,35	0,317	0,35	0,617	0,35	0,034	0,35	0,733
0,40	0,367	0,40	0,567	0,40	0,055	0,40	0,670
0,45	0,417	0,45	0,517	0,45	0,085	0,45	0,599
0,50	0,467	0,50	0,467	0,50	0,123	0,50	0,525
0,55	0,517	0,55	0,417	0,55	0,172	0,55	0,452
0,60	0,567	0,60	0,367	0,60	0,226	0,60	0,383
0,65	0,617	0,65	0,317	0,65	0,285	0,65	0,317
0,70	0,667	0,70	0,267	0,70	0,347	0,70	0,255
0,75	0,717	0,75	0,217	0,75	0,413	0,75	0,197
0,80	0,767	0,80	0,167	0,80	0,482	0,80	0,143
0,85	0,817	0,85	0,117	0,85	0,553	0,85	0,092
0,90	0,867	0,90	0,068	0,90	0,626	0,90	0,046
0,95	0,917	0,95	0,023	0,95	0,700	0,95	0,013
1,00	0,967	1,00	0,000	1,00	0,775	1,00	0,000

2.2.5 Probability of breaching a compartment from bottom damage

The probability P_B of breaching a compartment from bottom damage is to be calculated as follows:

$$P_B = P_{BL} P_{BT} P_{BV}$$

where:

P_{BL} : Probability the damage extends into the longitudinal zone bounded by X_a and X_f

$$P_{BL} = 1 - P_{Bf} - P_{Ba}$$

P_{BT} : Probability the damage extends into the transverse zone bounded by Y_p and Y_s

$$P_{BT} = 1 - P_{Bp} - P_{Bs}$$

P_{BV} : Probability the damage extends vertically above the boundary defined by z

$$P_{BV} = 1 - P_{Bz}$$

P_{Ba} , P_{Bf} , P_{Bp} and P_{Bs} are to be determined by linear interpolation from Tab 3 of probabilities for bottom damage, where:

P_{Ba} : Probability the damage lies entirely aft of location X_a / L

P_{Bf} : Probability the damage lies entirely forward of location X_i/L

P_{Bp} : Probability the damage lies entirely to port of the tank

P_{Bs} : Probability the damage lies entirely to starboard of the tank.

P_{Bz} , the probability the damage lies entirely below the tank, is to be determined as follows:

- for $z/D_s \leq 0,1$:

$$P_{Bz} = (14,5 - 67 z / D_s) (z / D_s)$$
- for $z/D_s > 0,1$:

$$P_{Bz} = 0,78 + 1,1 (z / D_s - 0,1)$$

P_{Bz} is not to be taken greater than 1.

Compartment boundaries X_a , X_i , Y_p , Y_s , and z are to be developed as follows:

X_a and X_i : As defined in [2.2.4]

Y_p : Transverse distance from the port-most point on the compartment located at or below the waterline d_B , to a vertical plane located $B_B/2$ to starboard of the ship's centreline, in m

Y_s : Transverse distance from the starboard-most point on the compartment located at or below the waterline d_B , to a vertical plane located $B_B/2$ to starboard of the ship's centreline, in m

z : Minimum value of z over the length of the compartment, where, at any given longitudinal location, z is the vertical distance from the lower point of the bottom shell at that longitudinal location to the lower point of the compartment at that longitudinal location, in m.

Table 3 : Probabilities for bottom damage

X_a/L	P_{Ba}	X_i/L	P_{Bf}	Y_p/B_B	P_{Bp}	Y_s/B_B	P_{Bs}
0,00	0,000	0,00	0,969	0,00	0,844	0,00	0,000
0,05	0,002	0,05	0,953	0,05	0,794	0,05	0,009
0,10	0,008	0,10	0,936	0,10	0,744	0,10	0,032
0,15	0,017	0,15	0,916	0,15	0,694	0,15	0,063
0,20	0,029	0,20	0,894	0,20	0,644	0,20	0,097
0,25	0,042	0,25	0,870	0,25	0,594	0,25	0,133
0,30	0,058	0,30	0,842	0,30	0,544	0,30	0,171
0,35	0,076	0,35	0,810	0,35	0,494	0,35	0,211
0,40	0,096	0,40	0,775	0,40	0,444	0,40	0,253
0,45	0,119	0,45	0,734	0,45	0,394	0,45	0,297
0,50	0,143	0,50	0,687	0,50	0,344	0,50	0,344
0,55	0,171	0,55	0,630	0,55	0,297	0,55	0,394
0,60	0,203	0,60	0,563	0,60	0,253	0,60	0,444
0,65	0,242	0,65	0,489	0,65	0,211	0,65	0,494
0,70	0,289	0,70	0,413	0,70	0,171	0,70	0,544
0,75	0,344	0,75	0,333	0,75	0,133	0,75	0,594
0,80	0,409	0,80	0,252	0,80	0,097	0,80	0,644
0,85	0,482	0,85	0,170	0,85	0,063	0,85	0,694
0,90	0,565	0,90	0,089	0,90	0,032	0,90	0,744
0,95	0,658	0,95	0,026	0,95	0,009	0,95	0,794
1,00	0,761	1,00	0,000	1,00	0,000	1,00	0,844

3 Piping arrangements

3.1 Provision regarding piping arrangements

3.1.1 Lines of piping that run through cargo tanks in a position less than 0,30 B_s from the ship's side or less than 0,30 D_s from the ship's bottom is to be fitted with valves or similar closing devices at the point at which they open into any cargo tank. These valves is to be kept closed at sea at any time when the tanks contain cargo oil, except that they may be opened only for cargo transfer needed for essential cargo operations.

Credit for reducing oil outflow through the use of an emergency rapid cargo transfer system or other system arranged to mitigate oil outflow in the event of an accident may be taken into account only after the effectiveness and safety aspects of the system are approved by the Society.

Part D

Service Notations

CHAPTER 8

CHEMICAL TANKERS

Section 1	General
Section 2	Ship Survival Capability and Location of Cargo Tanks
Section 3	Ship Arrangement
Section 4	Cargo Containment
Section 5	Cargo Transfer
Section 6	Materials for Construction
Section 7	Cargo Temperature Control
Section 8	Cargo Tank Venting and Gas-Freeing Arrangements
Section 9	Environmental Control
Section 10	Electrical Installations
Section 11	Fire Protection and Fire Extinction
Section 12	Mechanical Ventilation in the Cargo Area
Section 13	Instrumentation
Section 14	Protection of Personnel
Section 15	Special Requirements
Section 16	Operational Requirements
Section 17	Summary of Minimum Requirements
Section 18	List of Chemicals to which this Chapter Does Not Apply
Section 19	Index of Products Carried In Bulk
Section 20	Transport of Liquid Chemical Wastes
Section 21	Criteria for Assigning Carriage Requirements for Products Subject to the IBC Code

Section 1 General

1 General

1.1 Application

1.1.1 Ships complying with the requirements of this Chapter are eligible for the assignment of the service notation **chemical tanker**, in accordance with Pt A, Ch 1, Sec 2, [4.4.4].

1.1.2 Ships which are intended for the carriage of dangerous chemicals in bulk are to comply with the requirements of the latest version of the International Code for the Construction and Equipment of Ships Carrying Dangerous Chemicals in Bulk (IBC Code), as amended.

1.1.3 These Rules and the IBC Code refer to ships carrying products which are listed in the table in Chapter 17 of the IBC Code or in the current MEPC.2/Circular, and in Ch 8, Sec 17.

1.1.4 In general, this Chapter applies to cargo containment and handling systems and to the interfaces between these systems and the remainder of the ship, which are to comply with the additional applicable requirements indicated in Tab 1.

Table 1 : Additional applicable requirements

Item		Reference
Ship arrangement	L ≥ 65 m	• Part B
	L < 65 m	• NR600
Hull	L ≥ 65 m	• Part B
	L < 65 m	• NR600
Stability		• Part B
Machinery and cargo system		• Part C
Electrical installations:		• Part C
Automation		• Part C
Fire protection, detection and extinction		• Part C
Note 1: NR600: Hull Structure and Arrangement for the Classification of Cargo Ships less than 65 m and Non Cargo Ships less than 90 m.		

1.2 IBC Code requirements and the Society's rules

1.2.1 General

- For ships having the service notation **chemical tanker**, the IBC Code requirements are to be considered as rule requirements, unless otherwise specified, and with the exception indicated in [1.2.2].
- The rule requirements of this Chapter include:
 - additional requirements to the IBC Code
 - Society's interpretations of the IBC Code.
- The requirements of this Chapter are cross referenced to the applicable Chapters, Sections or paragraphs of the IBC Code, as appropriate, under the wording "IBC CODE REFERENCE".

1.2.2 IBC Code requirements not within the scope of classification

The following requirements of the IBC Code are not within the scope of classification:

- Chapter 1, Section 1.4 - Equivalents
- Chapter 1, Section 1.5 - Surveys and certification
- Chapter 2, as far as survival requirements after flooding are concerned, when the additional class notation **SDS** is not granted
- Chapter 16 - Operating requirements.

These requirements are applied by the Society when acting on behalf of the flag Administration, within the scope of delegation (see [1.2.4]).

1.2.3 Equivalences

As far as the requirements for class are concerned, the following wording in the IBC Code is to be given the meanings indicated in Tab 2.

Table 2 : Equivalences

IBC Code wording	Meaning for classification only
Administration	Society
IBC Code or Chemical Code	Part D, Chapter 8 of the Rules
Recognised Standard	Rules
should be	is to be or are to be (as appropriate)

1.2.4 Certificate of Fitness

- a) The responsibility for interpretation of the IBC Code requirements for the purpose of issuing an International Certificate of Fitness for the Carriage of Dangerous Chemicals in Bulk lies with the Administration of the state whose flag the ship is entitled to fly.
- b) Whenever the Society is authorised by an Administration to issue on its behalf the "Certificate of Fitness for the Carriage of Dangerous Chemicals in Bulk", or where the Society is authorised to carry out investigations and surveys on behalf of an Administration on the basis of which the "Certificate of Fitness for the Carriage of Dangerous Chemicals in Bulk" will be issued by the Administration, or where the Society is requested to certify compliance with the IBC Code, the full compliance with the requirements of the IBC Code, including the operative requirements mentioned in [1.2.2], is to be granted by the Society.

2 Additional requirements

2.1 Emergency towing arrangement

2.1.1 Emergency towing arrangements are to be fitted on chemical tankers of 20.000 dwt and above in accordance with Pt B, Ch 12, Sec 4, [3].

2.2 Steering gear

2.2.1 Additional requirements for steering gear of chemical tankers of 10000 dwt and above are given in Ch 7, Sec 4, [7].

3 Documentation to be submitted

3.1

3.1.1 Tab 3 lists the plans, information, analysis, etc. which are to be submitted in addition to the information required in the other Parts of the Rules for the parts of the ship not affected by the cargo, as applicable.

Table 3 : Documentation to be submitted

No	A/I	Document
1	I	List of products to be carried, including maximum vapour pressure, maximum liquid cargo temperature, cargo mass density and other important design conditions
2	I	General arrangement plan, showing location of cargo tanks and fuel oil, ballast and other tanks
3	A	Gas-dangerous zones plan
4	A	Location of void spaces and accesses to dangerous zones
5	A	Ventilation duct arrangement in gas-dangerous spaces and adjacent zones
6	A	Details of hull structure in way of cargo tanks, including support arrangement for tanks, saddles, anti-floating and anti-lifting devices, deck sealing arrangements, independent cargo tanks, etc.
7	A	Hull stress analysis
8	A	Hull ship-motion analysis, where a direct analysis is preferred to the methods indicated in Section 4
9	A	Intact and damage stability calculations
10	A	Scantlings, material and arrangement of the cargo containment system
11	A	Details of steel cladding or lining
12	A	Plans, arrangement and calculations of pressure/vacuum valves
Note 1: A = to be submitted for approval I = to be submitted for information.		

No	A/I	Document
13	A	Details of cargo handling, including arrangements and details of piping and fittings and details of heating system, if any
14	A	Details of cargo pumps
15	A	Details of process pressure vessels and relative valving arrangement
16	A	Bilge and ballast system in cargo area
17	A	Gas freeing system in cargo tanks including inert gas system
18	A	Ventilation system in cargo area
19	A	Details of electrical equipment installed in cargo area, including the list of certified safe equipment and apparatus and electrical bonding of cargo tanks and piping
20	A	Schematic electrical wiring diagram
21	A	Gas detection system
22	A	Cargo tank instrumentation
23	A	Details of fire-extinguishing appliances and systems in cargo area
24	I	Loading and unloading operation description, including cargo tank filling limits, where applicable
25	I	Procedure and arrangement manual
<p>Note 1: A = to be submitted for approval I = to be submitted for information.</p>		

Section 2 Ship Survival Capability and Location of Cargo Tanks

1 Freeboard and intact stability

1.1 Intact stability

1.1.1 General

IBC CODE REFERENCE: Ch 2, 2.2.2

The stability of the ship for the loading conditions in Pt B, Ch 3, App 2, [1.2.7] is to be in compliance with the requirements in Pt B, Ch 3, Sec 2.

1.1.2 Free surface effect of liquids

IBC CODE REFERENCE: Ch 2, 2.2.3

The free surface effect is to be calculated in accordance with Pt B, Ch 3, Sec 2, [4].

1.1.3 Information to be supplied

IBC CODE REFERENCE: Ch 2, 2.2.5

The Master of the ship is to be supplied with a Loading Manual as specified in Pt B, Ch 1, Sec 5, [2] and a Trim and Stability booklet as specified in Pt B, Ch 3, App 2.

2 Conditions of loading

2.1 Additional loading conditions for ships where additional class notation SDS is requested

2.1.1

IBC CODE REFERENCE: Ch 2, 2.9.2.3

Loading conditions other than those in the Loading Manual and the Trim and Stability booklet are to be previously submitted to the Society. Alternatively, such cases may be examined by the Master or a delegated officer when a loading instrument approved in accordance with the requirements in Pt B, Ch 1, Sec 5, [3] is installed on board.

3 Location of cargo tanks

3.1 Minimum distance of cargo tanks from shell

3.1.1 Exceptions

IBC CODE REFERENCE: Ch 2, 2.6.1

Any cargo tank, irrespective of its location, may be used for collecting contaminated cargo pump room bilge water or tank washings, as an exception to the requirements in IBC Code 2.6.1.1.

3.2 Suction wells

3.2.1

IBC CODE REFERENCE: Ch 2, 2.6.2

In general, the area of suction wells is not to be greater than that required to accommodate cargo pumps, suction pipes, valves, heating coils etc., and to ensure efficient flow and the necessary access for cleaning and maintenance.

4 Flooding assumptions for ships where additional class notation SDS is requested

4.1 Tunnels, ducts and pipes in the damaged zone

4.1.1 Strength of internal structures

IBC CODE REFERENCE: Ch 2, 2.7.7

Tunnels, ducts, pipes, doors, bulkheads and decks which might form watertight boundaries of intact spaces in the case of assumed conventional damage are to have minimum strength adequate to withstand the pressure height corresponding to the deepest equilibrium waterline in damaged conditions.

4.1.2 Progressive flooding

IBC CODE REFERENCE: Ch 2, 2.7.7

Progressive flooding is to be considered in accordance with Pt B, Ch 3, Sec 3, [3.3].

5 Standard of damage for ships where additional class notation SDS is requested

5.1 Damage to stepped machinery space forward bulkhead

5.1.1

IBC CODE REFERENCE: Ch 2, 2.8

The concept of a stepped machinery space forward bulkhead is already implicit in the requirements in IBC Code 3.2.1 and Regulation II-2/56 of SOLAS 74(83). For damage stability considerations, when the recess for a pump room or for a cargo pump room extends into the adjacent machinery space or cargo tank by more than 3 metres, damage is to be treated as defined in Fig 1.

Figure 1 : Damage to stepped machinery space forward bulkhead

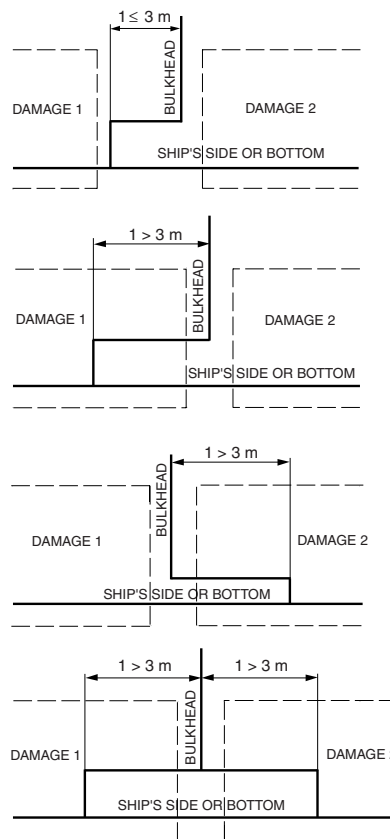

5.2 Longitudinal extension of damage to superstructure

5.2.1

IBC CODE REFERENCE: Ch 2, 2.8

The longitudinal extent of damage to the superstructure in the case of side damage to a machinery space aft, with the standards of damage as per IBC Code 2.8.1, is generally to be the same as the longitudinal extent of the side damage to the machinery space (see Fig 2).

6 Survival requirements for ships where additional class notation SDS is requested

6.1 General

6.1.1

IBC CODE REFERENCE: Ch 2, 2.9

Ships are to be capable of surviving the assumed damage specified in IBC Code 2.5.1 and 2.5.2 to the standard provided in IBC Code 2.8.1 and for the loading conditions in Pt B, Ch 3, App 2, [1.2.7] in a condition of stable equilibrium and such as to satisfy the criteria in IBC Code 2.9.

6.2 Intermediate stages of flooding

6.2.1

IBC CODE REFERENCE: Ch 2, 2.9.2.3

The criteria applied to the residual stability during intermediate stages of flooding are to be those relevant to the final stage of flooding as specified in IBC Code 2.9.3. However, small deviation from these criteria may be accepted by the Society on a case by case basis.

6.3 Definition of range of positive stability

6.3.1

IBC CODE REFERENCE: Ch 2, 2.9

The 20° range may be measured from any angle commencing between the position of equilibrium and the angle of 25° (or 30° if no deck immersion occurs) (see Fig 3).

6.4 Survival criterion

6.4.1 Unprotected openings

IBC CODE REFERENCE: Ch 2, 2.9.3.1

Other openings capable of being closed weathertight do not include ventilators (complying with ILLC 19(4)) that for operational reasons have to remain open to supply air to the engine room or emergency generator room (if the same is considered buoyant in the stability calculation or protecting openings leading below) for the effective operation of the ship.

6.5 Type 3 ships less than 125 m in length

6.5.1

IBC CODE REFERENCE: Ch 2, 2.8.1.6

The flooding of the machinery space, if located aft on a type 3 ship less than 125 m in length, is to comply as far as practicable with the criteria in IBC Code 2.9. Relaxation of parts of these requirements may be accepted on a case-by-case basis.

Figure 2 : Longitudinal extent of damage to superstructure

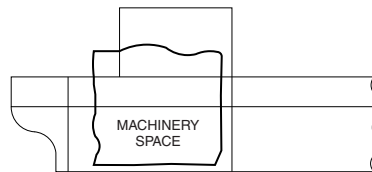
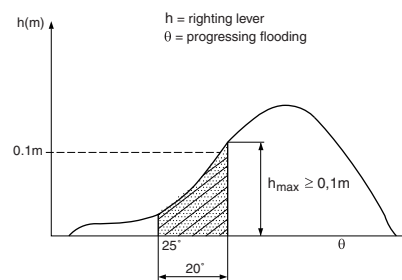

Figure 3 : Range of positive stability



Section 3 Ship Arrangement

1 Cargo segregation

1.1 Segregation of cargoes mutually reacting

1.1.1 Common edges

IBC CODE REFERENCE: Ch 3, 3.1.2

The common edge in a cruciform joint, either vertically or horizontally, may be considered a “double barrier” for the purpose of segregation:

- between mutually reactive products (see Fig 1)
- between water reactive products and water (see Fig 1).

Figure 1 : Segregation of mutually hazardously reactive cargoes

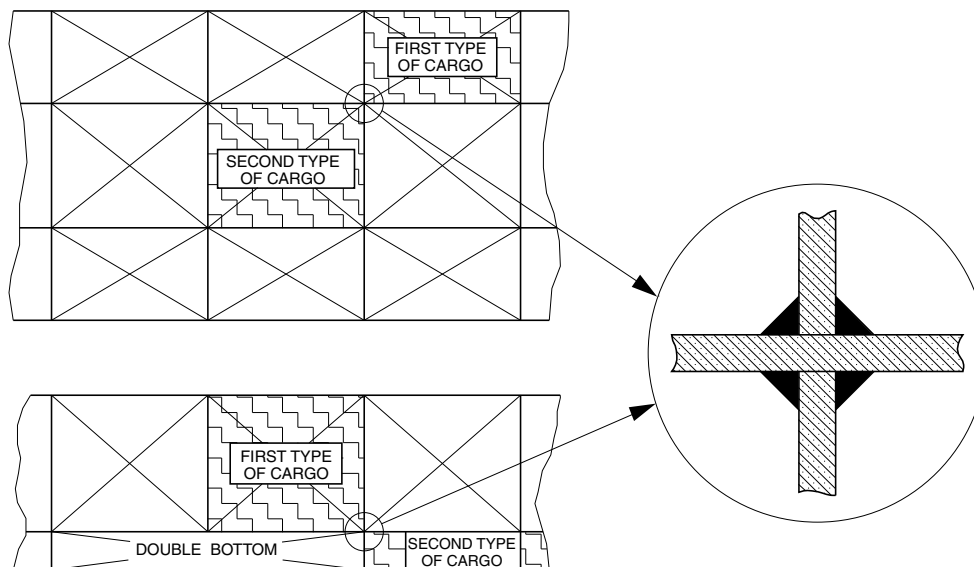

1.1.2 Chain lockers

IBC CODE REFERENCE: Ch 3, 3.1.2

The chain locker is to be arranged outside the hazardous areas defined in Ch 8, Sec 10 and at least 10 m measured horizontally from any vent outlet of a controlled tank venting system.

1.1.3 Location of fuel tanks in cargo area

On ships having the service notation **chemical tanker** and carrying liquid cargoes having a flashpoint not exceeding 60°C and/or toxic liquid cargoes, fuel tanks located with a common boundary to cargo or slop tanks are not to be situated within, nor extend partly into, the cargo tank block as defined in Ch 7, Sec 1, [1.2.4]. Such tanks may, however, be situated aft and/or forward of the cargo tank block. They may be accepted when located as independent tanks on open deck in the cargo area subject to spill and fire safety considerations.

The arrangement of independent fuel tanks and associated fuel piping systems, including the pumps, may be as for fuel tanks and associated fuel piping systems located in the machinery spaces. For electrical equipment, requirements applicable to hazardous area classification must however be met.

Note 1: For the purpose of this requirement, toxic liquid cargoes include those for which toxic vapour detection is specified in column “k” of the table of chapter 17 of the IBC Code.

1.2 Cargo piping arrangement

1.2.1 Bow or stern loading arrangement

IBC CODE REFERENCE: Ch 3, 3.1.3

The requirement in IBC Code 3.1.3 is considered to be satisfied if the requirements in IBC Code 3.7, relevant to bow or stern loading and unloading arrangements, are complied with.

2 Accommodation, service and machinery spaces and control stations

2.1 Location of paint lockers

2.1.1

IBC CODE REFERENCE: Ch 3, 3.2.1

Paint lockers, regardless of their use, cannot be located above the cargo area.

2.2 Air intakes and other openings to accommodation spaces

2.2.1

IBC CODE REFERENCE: Ch 3, 3.2.2

The requirements relevant to air intakes in IBC Code 3.2.2 are also intended to be applicable to air outlets. This interpretation also applies to the requirements in IBC Code 3.2.3, 3.7.4, 8.2.3, 15.12.1.3 and 19.3.8.

2.3 Windows, sidescuttles and doors to accommodation spaces

2.3.1 General requirements

IBC CODE REFERENCE: Ch 3, 3.2.3

- a) Access facing the cargo area or other prohibited zones is to be restricted to stores for cargo-related and safety equipment, cargo control stations and emergency shower spaces.
- b) Access to forecastle spaces containing sources of ignition may be permitted through doors facing cargo area provided the doors are located outside hazardous areas as defined in Pt C, Ch 2, Sec 1, [3.25.3] and Ch 8, Sec 10, Tab 1 or Ch 8, Sec 10, Tab 2.
However, for small ships alternative arrangements may be specially considered by the Society.
- c) The bolt spacing for bolted plates mentioned in the paragraph in the reference is to be such as to guarantee a suitable gas-tightness.

2.3.2 Ships fitted with deckhouses originating from main deck

IBC CODE REFERENCE: Ch 3, 3.2.3

On all chemical tankers, regardless of the type of products to be carried, where a deckhouse is substituted for a superstructure and liquid products could flow along the sides of the house, the house front is to be continued to the sides of the ship in the form of a sill, or a permanent spillage barrier is to be arranged as described in Regulation II-2/56.6 of SOLAS 74(83).

2.4 Access to the bow

2.4.1 Ships having the service notation **chemical carrier** are to be provided with the means to enable the crew to gain safe access to the bow even in severe weather conditions. Such means of access are to be approved by the Society.

Note 1: The Society accepts means of access complying with the Guidelines for safe access to tanker bows adopted by the Marine Safety Committee of IMO by Resolution MSC.62 (67).

3 Cargo pump rooms

3.1 General requirement

3.1.1 Means of escape

IBC CODE REFERENCE: Ch 3, 3.3.1

In general, a cargo pump room is to be provided with one set of access/escape ladders. Where it is envisaged that personnel are normally employed in a pump room or the pump room is unusually large, an additional means of escape may be required.

3.1.2 Segregation

IBC CODE REFERENCE: Ch 3, 3.3.1

Cargo pump rooms and pump rooms may not give direct access to other ship spaces and are to be separated from adjacent spaces by means of gas-tight bulkheads and/or decks.

3.2 Machinery driven by shafting passing through pump room bulkheads

3.2.1

IBC CODE REFERENCE: Ch 3, 3.3.7

- a) Bulkhead or deck penetrations of cargo pump rooms, or of pump rooms intended for runs of shafts driving pumps and/or fans, are to be provided with gas-tight sealing devices to the satisfaction of the Society.
- b) Lubrication or other means of ensuring permanence of gas-tightness of the above-mentioned sealing devices is to be arranged in such a way that it can be checked from outside the cargo pump room.

4 Access to spaces in the cargo area

4.1 General

4.1.1 Independent cargo tanks

Where independent tanks are installed in hold spaces, requirements in [4.2] and [4.3] are to be applied, as far as practicable, to ballast and void spaces adjacent to hold spaces.

When such requirements are found to be incompatible with the size and arrangement of the ship, smaller dimensions may be accepted by the Society, providing convenient access to any part of those spaces is maintained.

4.1.2 Access to fuel oil tanks

IBC CODE REFERENCE: Ch 3, 3.4.1

The requirements in IBC Code 3.4.1 apply to fuel oil tanks adjacent to cargo tanks even if such fuel oil tanks are not included in the cargo area.

4.1.3 Accesses and escapes from double bottom tanks and similar spaces

IBC CODE REFERENCE: Ch 3, 3.4.1

To cater for restrictions in the movement of personnel and to limit the time needed for a possible emergency escape, two separate means of access are generally to be fitted in double bottom tanks and similar spaces where obstructions impede movement. The two accesses are to be as widely separated as practicable. Only one access may be approved in special circumstances if, it being understood that the escapes have the required dimensions, the ability to readily traverse the space and to remove an injured person can be proved to the satisfaction of the Society.

4.2 Horizontal openings

4.2.1

IBC CODE REFERENCE: Ch 3, 3.4.2

The shape of the minimum acceptable clear opening of 600 mm by 600 mm is indicated in Fig 2.

Figure 2 : Shape of minimum acceptable clear opening of 600 mm by 600 mm

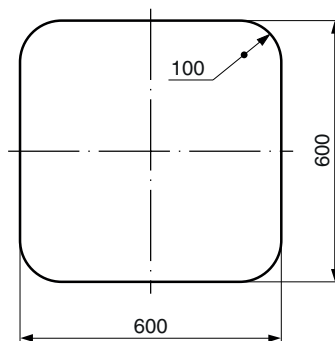

4.3 Vertical openings

4.3.1

IBC CODE REFERENCE: Ch 3, 3.4.3

For pressure cargo tanks only, access openings may be circular openings having a diameter not less than 600 mm.

The minimum size of vertical oval openings is defined in Fig 3.

Figure 3 : Minimum size of vertical oval openings

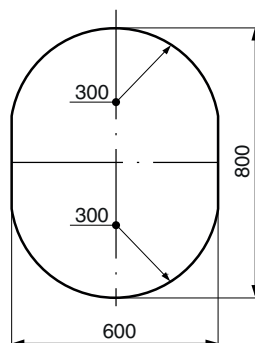

5 Bilge and ballast arrangements

5.1 Ballast segregation

5.1.1 Filling arrangement

IBC CODE REFERENCE: Ch 3, 3.5.1

Where filling arrangements for ballast tanks located in the cargo area are provided in the machinery spaces, a non-return valve and removable spool piece are to be fitted in the supply line outside the machinery spaces.

5.1.2 Eductors

IBC CODE REFERENCE: Ch 3, 3.5.1

An eductor situated in the cargo area using water power from pumps in the machinery spaces may be accepted as a means to discharge permanent ballast from tanks and/or double bottoms adjacent to cargo tanks, provided the supply line is above deck level and a non-return valve and removable spool piece are fitted in the supply line outside the machinery space (see Fig 4).

Figure 4 : Discharge arrangement

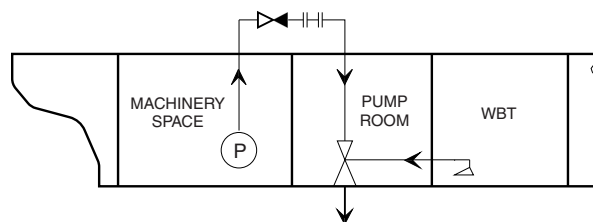

5.1.3 Fore peak ballast system

IBC CODE REFERENCE: Ch 3, 3.5.1

The fore peak tank can be ballasted with the system serving other ballast tanks within the cargo area, provided:

- the fore peak tank is considered as a hazardous area, and the hazardous area classification is defined in accordance with Ch 8, Sec 10
- the vent pipe openings are located on open deck at an appropriate distance from sources of ignition. In this respect, the hazardous zones distances are to be defined in accordance with Ch 8, Sec 10
- means are provided, on the open deck, to allow measurement of flammable gas concentrations within the tank by a suitable portable instrument
- the access to the fore peak tank is direct from open deck. Alternatively, indirect access from the open deck to the fore peak tank through an enclosed space may be accepted provided that:
 - In case the enclosed space is separated from the cargo tanks by cofferdams, the access is through a gas tight bolted manhole located in the enclosed space and a warning sign is provided at the manhole stating that the fore peak tank may only be opened after:
 - it has been proven to be gas free; or
 - any electrical equipment which is not certified safe in the enclosed space is isolated.
 - In case the enclosed space has a common boundary with the cargo tanks and is therefore a hazardous area, the enclosed space can be well ventilated.

5.2 Ballast filling arrangement

5.2.1 Clarification

IBC CODE REFERENCE: Ch 3, 3.5.2

The filling of cargo tanks with ballast may be performed at deck level by means of pumps serving permanent ballast tanks, as specified in IBC Code 3.5.2, provided that a removable spool piece or flexible hose plus a shut-off valve are fitted on the inlet to the cargo tank. The shut-off valve is in addition to the required non-return valve. Consideration is to be given to the arrangement of the in-tank piping and the possible creation of static electricity (see Fig 4).

5.3 Bilge

5.3.1 Arrangement

IBC CODE REFERENCE: Ch 3, 3.5.3

The relaxation relevant to the bilge system for spaces which are separated from cargo tanks by a double bulkhead is to be understood as limited to spaces not enclosing piping which may contain cargo.

5.3.2 Use of cargo pumps as bilge pumps

IBC CODE REFERENCE: Ch 3, 3.5.3

- a) Cargo pumps may also be used as bilge pumps provided they are connected to the bilge piping through a shut-off valve and a non-return valve arranged in series.
- b) In the case of carriage of corrosive liquids, one of the cargo pumps may be used for bilge service provided it is connected to the bilge piping through two shut-off valves plus a non-return valve arranged in series.
- c) In cargo pump rooms of ships carrying toxic or corrosive products, suitable means for conveying spills from cargo pumps and valves to collecting trays are to be fitted. Trays may also consist of part of the pump room bottom, suitably bounded and protected against the corrosive action of products. Spills may be disposed of by means of suitable pumps or eductors. In the case of carriage of mutually incompatible products, the above-mentioned means for collecting and disposing of spills are to be different and separated from each other.

6 Integrated cargo and ballast systems

6.1

6.1.1 Integrated cargo and ballast pumps are to comply with the provisions of Ch 7, Sec 4, [3.6].

7 Bow or stern loading and unloading arrangements

7.1 Coamings

7.1.1

IBC CODE REFERENCE: Ch 3, 3.7.7

In general, the height of the coaming is to be not less than 150 mm. In any case, it is to be not less than 50 mm above the upper edge of the sheerstrake.

Section 4 Cargo Containment

Symbols

k : Material factor for steel, defined in Pt B, Ch 4, Sec 1, [2.2].

1 General

1.1 Application

1.1.1 The requirements of this sections are to be applied in addition to the Chapter 4 of the IBC Code.

2 Structure design principles

2.1 Materials

2.1.1 Steels for hull structure

In addition to the requirements of Pt B, Ch 4, Sec 1, [2], materials of cargo tanks are to be considered by the Society on a case-by-case basis for all the products intended to be carried.

2.1.2 Rolled plates

IBC CODE REFERENCE: CHAPTER 4

Rolled plates of non-alloyed steel or stainless steel may be used for the construction of tanks. Mechanical characteristics, approval procedure and testing of these plates are to comply with the applicable requirements in NR216 Materials.

2.1.3 Young's modulus for stainless steels

IBC CODE REFERENCE: CHAPTER 4

For stainless steels, Young's modulus is to be taken equal to 193000 N/mm².

2.1.4 Rubber and synthetic material liner

IBC CODE REFERENCE: CHAPTER 4

The suitability of rubber or synthetic material lining is to be considered by the Society on a case-by-case basis.

2.2 Hull structure

2.2.1 Framing arrangement

IBC CODE REFERENCE: CHAPTER 4

In general, within the cargo tank region of chemical tankers of more than 90 m in length, the bottom, the inner bottom and the deck are to be longitudinally framed.

Different framing arrangements are considered by the Society on a case-by-case basis, provided that they are supported by direct calculations.

2.3 Bulkhead structure

2.3.1 Corrugated bulkhead connections

For ships with $L < 120$ m, vertically corrugated transverse or longitudinal bulkheads may be connected to the double bottom and deck plating (see Fig 1).

Figure 1 : Corrugated bulkhead connections without stool

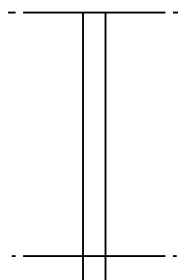

For ships with $L \geq 120$ m, a lower and an upper stool are generally to be fitted (see Fig 2). Different arrangements may be considered by the Society on a case-by-case basis, provided that they are supported by direct calculations carried out according to Pt B, Ch 8, App 1. These calculations are to investigate, in particular, the zones of connection of the bulkhead with bottom and deck plating and are to be submitted to the Society for review.

Figure 2 : Corrugated bulkhead connections with lower and upper stools

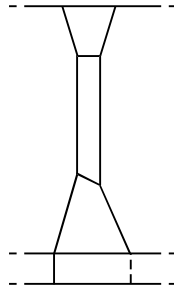

3 Hull girder loads

3.1 Still water loads

3.1.1 Loading conditions

In addition to the requirements in Pt B, Ch 5, Sec 4, [2.1], still water loads are to be calculated for the following loading conditions:

- homogeneous loading conditions (excluding tanks intended exclusively for segregated ballast tanks) at maximum draught
- partial loading conditions (see [3.1.2])
- high density cargo, heated cargo and segregated cargo loading conditions
- any specified non-homogeneous loading condition
- light and heavy ballast conditions
- mid-voyage conditions related to tank cleaning or other operations where these differ significantly from the ballast conditions.

3.1.2 Partial filling

Loading conditions with partial filling of the tanks by cargoes with a mass density above the cargo mass density used for the design may be allowed.

3.2 Load combinations for direct strength analysis

3.2.1 The loading conditions to be considered for the direct strength analysis are defined in Ch 7, Sec 3, [5.1].

4 Hull scantlings

4.1 Plating

4.1.1 Calculation of equivalent thickness for clad plates made of non-alloyed steel - stainless steel

The clad plate thickness is to be not less than that obtained from the following formula:

$$t_p = t + t_s \left(1 - \frac{E_1}{206000} \right)$$

where:

t : Thickness, in mm, of the clad plate, to be obtained from the applicable formulae in Pt B, Ch 7, Sec 4, as if it were made of homogeneous material with the following properties:

- elastic modulus, in N/mm², to be taken equal to:
 $E = 206000$
- material factor, to be obtained from the following formula:

$$k_0 = k \frac{E_1}{206000}$$

k : Material factor of the rolled stainless steel plate, defined in Pt B, Ch 4, Sec 1, [2.2]

E_1 : Elastic modulus, in N/mm², of the rolled stainless steel plate

t_s : Thickness, in mm, of the stainless steel cladding, to be taken not less than 2,0 mm

Stainless steel cladding thicknesses other than those above are to be considered by the Society on a case-by-case basis.

5 Scantlings of independent tank structures

5.1 General

5.1.1 Ships designed with independent cargo tanks are to comply with the applicable provisions of Part D, Chapter 7.

6 Supports of independent tanks

6.1 General

6.1.1 Ships designed with independent cargo tanks are to comply with the applicable provisions of Part D, Chapter 7.

7 Other structures

7.1 Machinery space

7.1.1 Extension of the hull structures within the machinery space

IBC CODE REFERENCE: CHAPTER 4

Longitudinal bulkheads carried through cofferdams are to continue within the machinery space and be used preferably as longitudinal bulkheads for liquid cargo tanks. This extension is to be compatible with the shape of the structures of the double bottom, of the deck and of platforms in the machinery space.

8 Protection of hull metallic structures

8.1 Aluminium coatings

8.1.1

IBC CODE REFERENCE: CHAPTER 4

The use of aluminium coatings containing greater than 10% aluminium by weight in the dry film is prohibited in the cargo tanks, cargo tank deck area, pump rooms, cofferdams or any other area where cargo vapour may accumulate.

8.2 Passivation treatment

8.2.1

IBC CODE REFERENCE: CHAPTER 4

For a stainless steel structure, a passivation treatment is to be made carefully on the whole area of the tanks for a new ship, and on the whole repaired area in the case of repairs. This applies in particular to the passivation treatment of the welds.

9 Construction and testing

9.1 Welding and weld connections

9.1.1 General

The requirements in [9.1.2] to [9.1.5] are to be considered in addition to the applicable requirements in Pt B, Ch 13, Sec 2 and Pt B, Ch 13, Sec 3.

9.1.2 Welding of bulkheads of cargo integral tanks of type 1 chemical carriers

IBC CODE REFERENCE: CHAPTER 4

The boundaries of bulkheads of cargo integral tanks of type 1 chemical carriers are to be connected, for their whole length, to the hull structures by means of full penetration welding. As an alternative to full penetration weldings, the weld preparation is to be indicated on the drawings and non-destructive examinations are to be carried out on 100% of the welds.

9.1.3 Welding of bulkheads of cargo integral tanks of type 2 chemical carriers

IBC CODE REFERENCE: CHAPTER 4

The lower part (over 10% in height, as a minimum) of the boundaries of bulkheads of cargo integral tanks, i.e. the connection with the bottom (or double bottom, if any) and the connection with the lower part of the sloping plates, of type 2 chemical carriers are to be connected, for their whole length, to the hull structures by means of full penetration welding. As an alternative to full penetration weldings, the weld preparation is to be indicated on the drawings and non-destructive examinations are to be carried out on 100% of the welds.

The other part of the tank boundaries may be connected by means of fillet welding.

9.1.4 Welding of stiffeners made of non-alloyed steel to stainless steel plates

IBC CODE REFERENCE: CHAPTER 4

In general, stiffeners made of non-alloyed steel may not be directly welded to thin stainless steel plates.

However, where the welding of stiffeners and hull components made of normal strength steel to stainless steel plates is deemed acceptable by the Society, such welding is to be performed using austenitic-ferritic electrodes with high-grade nickel and chromium, such as the electrode type with 24% Cr, 14% Ni and 3% Mo.

9.1.5 Welding on clad plates

IBC CODE REFERENCE: CHAPTER 4

Welds carried out on clad plates are to be considered by the Society on a case-by-case basis.

In particular, when fillet welding is carried out directly on the rolled plate, the ultrasonic inspection of the plating bond is to be performed on a strip bond 100 mm wide, centred on the plate perpendicular to the plating. This ultrasonic inspection is to be carried out in accordance with NR216 Materials and Welding, Ch 3, Sec 11, [1.9].

9.2 Structural details

9.2.1 The specific requirements in Pt B, Ch 13, Sec 5, [2.3] for ships with the service notation **chemical tanker** are to be complied with.

Section 5 Cargo Transfer

1 Piping scantlings

1.1 General

1.1.1 Other requirements

IBC CODE REFERENCE: Ch 5, 5.1

Cargo pipes and accessories are to satisfy requirements of Pt C, Ch 1, Sec 10.

1.2 Pipe classes

1.2.1

IBC CODE REFERENCE: Ch 5, 5.1

According to Pt C, Ch 1, Sec 10, [1.5.2], cargo pipes and associated accessories are considered as:

- class I when the design pressure is above 1,5 MPa, or the pipe is intended for toxic substances requesting full compliance with Ch 17, 15.12 of the IBC Code
- class II when the design pressure is equal to or less than 1,5 MPa
- class III when they are open ended or placed inside cargo tanks.

1.3 Pipe wall thickness calculation

1.3.1 Piping subjected to green seas

IBC CODE REFERENCE: Ch 5, 5.1.1

For piping subjected to green seas, the design pressure P , in MPa, in the formula in 5.1.1 of the IBC Code is to be replaced by an equivalent pressure P' given by the following formula:

$$P' = \frac{1}{2} \left(P + \sqrt{P^2 + 0,006 R' K \frac{D_C}{D}} \right)$$

where:

- D_C : External diameter of the pipe taking into account the insulation (in mm), whose thickness is to be taken at least equal to:
- 40 mm if $D \leq 50$ mm
 - 80 mm if $D \geq 150$ mm
- Intermediate values are to be determined by interpolation
- R' : Drag corresponding to the effect of green seas, in daN/mm², such as given in Tab 1 as a function of the location of the pipes and of their height H (in m) above the deepest loadline; intermediate values are to be determined by interpolation.

1.3.2 Corrosion allowance

IBC CODE REFERENCE: Ch 5, 5.1.1

The coefficient C (added corrosion thickness) for the formula in 5.1.1 of the IBC Code is normally to be equal to at least 3 mm. The Society may accept a lesser value for pipes made of austenitic or austenitic-ferritic stainless steel, pipes with internal lining or, if applicable, pipes with acceptable external protective lining or painting.

Table 1 :

External diameter of pipe (1)	Aft of the quarter of the ship's length			Forward of the quarter of the ship's length		
	$H \leq 8$	$H = 13$	$H \geq 18$	$H \leq 8$	$H = 13$	$H \geq 18$
≤ 25	1500	250	150	2200	350	150
50	1400	250	150	2000	350	150
75	1100	250	150	1600	350	150
100	700	250	150	700	350	150
≥ 150	500	250	150	700	350	150

(1) D_C if the pipe is insulated, D otherwise.

2 Piping fabrication and joining details

2.1 Pipes not required to be joined by welding

2.1.1

IBC CODE REFERENCE: Ch 5, 5.2.2

Cargo piping is to be welded except for necessary flanged connections to valves, expansion joints (as permitted in 5.2.2.1 of the IBC Code), spool pieces and similar fittings or where required for coating, lining, fabrication, inspection or maintenance.

2.2 Expansion joints

2.2.1

IBC CODE REFERENCE: Ch 5, 5.2.4

The use of bellows is not permitted for corrosive and polymerising products, except if provision is made to prevent stagnation of liquids.

2.3 Non-destructive testing of welded joints

2.3.1

IBC CODE REFERENCE: Ch 5, 5.2.5

- a) Butt welded joints of pipes and accessories are to be submitted to radiographic examination. A minimum of 10% of the welded joints are to be selected at random in agreement with the Surveyor. The selected joints are to be tested over their full length. The Surveyor may require to extend the number of joints to be tested depending on the results of the inspection.
- b) All butt welded joints of pipes and accessories are to be submitted to liquid penetrant examination or equivalent method over their full length
- c) Relaxation of the above requirements may be considered by the Society on a case-by-case basis for pipes welded at workshops. However, this only applies to ships exclusively intended to carry cargoes with minor fire risk.

3 Piping arrangements

3.1 Arrangement of cargo piping

3.1.1 Arrangement of cargo piping under deck

IBC CODE REFERENCE: Ch 5, 5.5.2

The intent of the provisions in 5.5.2 of the IBC Code is to preclude the hazard of cargo leaking past a shut-off valve gland into the space where the valve is located.

3.1.2 Arrangement of cargo piping on deck

IBC CODE REFERENCE: Ch 5, 5.5.2

Cargo piping on cargo tanks is to be extended down to the bottom of each tank.

3.1.3 Arrangement of cargo piping inside cargo tanks

IBC CODE REFERENCE: Ch 5, 5.5.2

The ends of cargo tank filling pipes are to be located as near as possible to the tank bottom in order to reduce the risk of generating static electricity.

3.1.4 Pipe connections

IBC CODE REFERENCE: Ch 5, 5.3.2

Flanges are to be provided on connections to prevent the projection of liquids in case of leakage if pipes are intended to carry cargoes involving serious risks of skin toxicity.

3.1.5 Aluminised pipes

IBC CODE REFERENCE: Ch 5, 5.5

Aluminised pipes may be permitted in ballast tanks, in inerted cargo tanks and, provided the pipes are protected from accidental impact, in hazardous areas on open deck.

3.2 Removable piping systems

3.2.1

IBC CODE REFERENCE: Ch 5, 5.5

Pumps, piping and associated fittings are to constitute a permanently fitted system; in general, removable parts are not allowed, except for specific cases for which it can be proved, to the satisfaction of the Society, that no effective alternative solutions are

available. In such circumstances, the safety measures deemed necessary will be considered by the Society on a case-by-case basis.

4 Cargo transfer control systems

4.1 General

4.1.1

IBC CODE REFERENCE: Ch 5, 5.6.1

- a) One blank flange is to be provided in addition to the stop valve required in 5.6.1.2 of the IBC Code at each cargo hose connection.
- b) The requirements of 5.6.1 of the IBC Code are not intended to be additional to those for piping below deck in 5.5.2 and 5.5.3 of the IBC Code.

4.2 Control, monitoring and alarm devices and cargo control room

4.2.1

IBC CODE REFERENCE: Ch 5, 5.6

- a) The cargo pump control is to be fitted in a position which is readily accessible, even in the event that the cargo piping or hoses break. This position is to be clearly indicated.
- b) Where a cargo control room is fitted, the following controls, monitoring and alarms are to be connected to this room:
 - cargo pump control
 - control of loading/unloading valves
 - level gauges
 - temperature indicators
 - high level alarms
 - very high level alarms
 - high/low temperature alarms
 - high/low pressure alarms
 - fixed gas detecting system alarms.
- c) In general, high/low temperature alarms are also to be transduced to the navigating bridge.
- d) The cargo control room is to be located above the weather deck and may be considered as a dangerous space or a safe space, depending on its location and on the possible presence of a product or of its vapours. If it is considered a dangerous space, it is to be provided with a ventilation system capable of supplying at least 20 air changes per hour, it is not to be located in the accommodation area and only safe type electrical equipment is allowed.
- e) A cargo control room without cargo pump and valve control is defined as a “cargo control station”.

5 Ship’s cargo hoses

5.1 Compatibility

5.1.1

IBC CODE REFERENCE: Ch 5, 5.7.1

The requirement of 5.7.1 of the IBC Code applies to cargo hoses carried on board the vessel and “compatibility with the cargo” means that:

- a) the cargo hose does not lose its mechanical strength or deteriorate unduly when in contact with the cargo, and
- b) the cargo hose material does not affect the cargo in a hazardous way.

Consideration is to be given to internal and external surfaces with respect to the above where hoses may be used as an integral part of, or connected to, emergency cargo pumps and submerged in the cargo tank.

6 Bonding

6.1 Static electricity

6.1.1 Acceptable resistance

IBC CODE REFERENCE: Ch 10, 10.3

To avoid the hazard of an incendive discharge due to the build-up of static electricity resulting from the flow of the liquid/gases/vapours, the resistance between any point on the surface of the cargo and slop tanks, piping systems and equipment, and the hull of the ship is not to be greater than $10^6 \Omega$.

6.1.2 Bonding straps

IBC CODE REFERENCE: Ch 10, 10.3

Bonding straps are required for cargo and slop tanks, piping systems and equipment which are not permanently connected to the hull of the ship, for example:

- a) independent cargo tanks
- b) cargo tank piping systems which are electrically separated from the hull of the ship
- c) pipe connections arranged for the removal of the spool pieces.
- d) wafer-style valves with non-conductive (e.g PTFE) gaskets or seals.

Where bonding straps are required, they are to be:

- a) clearly visible so that any shortcoming can be clearly detected
- b) designed and sited so that they are protected against mechanical damage and are not affected by high resistivity contamination, e.g. corrosive products or paint
- c) easy to install and replace.

7 Certification, inspection and testing

7.1 Application

7.1.1 The provisions of this Article are related to cargo piping and other equipment fitted in the cargo area. They supplement those given in Pt C, Ch 1, Sec 10, [20] for piping systems.

7.2 Inspection and testing

7.2.1 Testing of materials

Where required in Tab 2, materials used for pipes, valves and fittings are to be subjected to the tests specified in Pt C, Ch 1, Sec 10, [20.4.2].

7.2.2 Inspection of welded joints

Where required in Tab 2 Pt C, Ch 1, Sec 10, [3.6] the requirements of Pt C, Ch 1, Sec 10, [3.6.3] are not applicable for chemical carrier cargo piping and are to be replaced by those of [2.3.1].

7.2.3 Hydrostatic testing

IBC CODE REFERENCE: Ch 5, 5.4.2

- a) Where required in Tab 2, cargo pipes, valves, fittings and pump casings are to be submitted to hydrostatic tests in accordance with the relevant provisions of Pt C, Ch 1, Sec 10, [20.5].
- b) Expansion joints and cargo hoses are to be submitted to hydrostatic tests in accordance with the relevant provisions of Pt C, Ch 1, Sec 10, [20.5].
- c) Where fitted, bellow pieces of gas-tight penetration glands are to be pressure tested.

7.2.4 Tightness tests

Tightness of the gas-tight penetration glands is to be checked.

Note 1: These tests may be carried out in the workshops or on board.

7.2.5 Certification

Inspection, tests and certification requirements for cargo piping and other equipment fitted in the cargo area are given in Tab 2.

7.3 Shipboard tests

7.3.1 Pressure test

IBC CODE REFERENCE: Ch 5, 5.4.3

After installation on board, the cargo piping system is to be checked for leakage under operational conditions.

Table 2 : Inspection and testing at works

No	Item	Tests for materials		Inspections and tests for the products			References to the Rules
		Y/N (1)	Type of material certificate (2)	during manufacturing (1)	after completion (1) (3)	Type of product certificate (2)	
1	seamless or stainless steel cargo pipes	Y	<ul style="list-style-type: none"> C where $ND > 25\text{mm}$ W where $ND \leq 25\text{mm}$ 	Y (4)	Y	C	[7.2.1] [7.2.1] [7.2.2] [7.2.3]
2	pipes of class II, cargo valves and fittings	Y	<ul style="list-style-type: none"> C where $ND > 100\text{mm}$ W where $ND \leq 100\text{mm}$ 	Y (4)	Y	C	[7.2.1] [7.2.1] [7.2.2] [7.2.3]
3	expansion joints and cargo hoses	Y (5)	W	N	Y	C	[7.2.1] [7.2.3]
4	cargo pumps	Y	<ul style="list-style-type: none"> C for cast body W for welded construction 	Y (6)	Y	C	see note (6) [7.2.3]
5	gas-tight penetration glands	N		N	Y	C	[7.2.3], [7.2.4]
6	cargo tank P/V valves	Y	W	Y	Y	C	[7.2.1] [7.2.2] [7.2.3] Ch 8, Sec 8, [2.1.1]
7	flame arresters	N		N	Y	C	see note (3)

- (1) Y = required, N = not required.
 (2) C = class certificate, W = works' certificate.
 (3) includes the checking of the rule characteristics according to the approved drawings.
 (4) only in the case of welded construction.
 (5) if metallic.
 (6) inspection during manufacturing is to be carried out according to a program approved by the Society.

Section 6 Materials for Construction

1 General

1.1 Material and coating characteristics

1.1.1

IBC CODE REFERENCE: Ch 6

- a) Materials and coating systems of structures and equipment which may come into contact with liquid cargo or vapour are to be selected in accordance with the list of cargoes intended to be carried.
- b) The resistance of materials and coatings and their compatibility with intended cargoes are the responsibility of the Builder or Owner. All supporting documents are, however, to be given to the Society to permit the drafting of the list of cargoes annexed to the classification certificate.

Copy of the charts of coating and/or material resistance issued by the manufacturers is to be kept on board. These documents are to indicate the possible restrictions relative to their use.

- c) As a general requirement, the provisions under NR216 Materials and Welding apply. Materials for tanks are, in any case, to have properties which are not lower than those of hull steels used according to NR216 Materials and Welding.
- d) The above-mentioned materials are, in themselves, to be resistant to the action of the products to be carried. However, materials which are not, in themselves, resistant to such action may be used, provided they are protected by resistant materials after the positive outcome of prior checks and tests performed to the satisfaction of the Society. In this case, the Society may also require surveys to be carried out at shorter intervals than those between normal surveys.
- e) In the construction of cargo tanks intended to carry cargo and sea water ballast alternately, the utmost care is to be given to the selection of structural material (in general austenitic stainless steel) with particular attention to its resistance to different types of isolated corrosion:
 - pitting
 - stress corrosion
 - interstice corrosion.

In addition, these structures are to be constructed with the same type of material to avoid galvanic corrosion, which would arise if dissimilar materials were present. In addition to the structures, the above is also intended to apply to the materials of systems, devices and apparatuses fitted in the tanks.

- f) Sea water ballast tank structures may be partly of stainless steel and partly of hull steel, provided suitable measures are taken against hull steel corrosion. The use of appropriate protective coatings is subject to the positive outcome of the previous checks and tests, to the satisfaction of the Society, which may also require surveys to be performed at shorter intervals than for normal surveys. In estimating the suitability of the protective system, the Society may also require that the cathodic area is drastically reduced (for example, by also suitably protecting stainless steel structures) for the purpose of avoiding extremely isolated corrosion in hull steel structures which could possibly turn out, for various reasons, not to be protected by coating.
- g) The use of aluminium coatings is prohibited in the cargo tanks, cargo tank deck area, pump rooms, cofferdams or any other area where cargo gas may accumulate.

2 Special requirements for materials

2.1 Miscellaneous requirements

2.1.1 Non-metallic materials

IBC CODE REFERENCE: Ch. 6

Non-metallic materials used in cargo tanks and connected equipment are to be suitable for the liquids and vapours to which they are exposed.

2.1.2 Primers

IBC CODE REFERENCE: Ch. 6

Primers containing zinc may not be used for stainless steel. Where such type of primer is used for other items which are welded to stainless steel, provisions are to be made to avoid the contamination of the stainless steel by zinc.

Section 7 Cargo Temperature Control

1 General

1.1 Heated cargoes

1.1.1 Approval

The capacity of a ship to maintain specific cargoes under heated conditions is the responsibility of the Builder or the Owner. However, all relevant supporting documents are to be given to the Society in order to establish the list of cargoes possibly attached to the classification certificate as per Pt A, Ch 1, Sec 2, [4.4.4].

1.1.2 Application

Except for ships intended for restricted voyages, any cargo with a melting point equal to 20°C, or above, is to be capable of being maintained under heated conditions.

Attention is drawn to the fact that, for safety reasons, certain cargoes are not to be heated above a specific temperature.

1.1.3 Temperature indication

When a ship is fitted with a heating system capable of maintaining the liquid temperature above 90°C, the ship's structure and materials are to be checked for this temperature and the maximum permissible temperature is to be stated on the classification certificate or on a memorandum.

1.2 Cargo heating and cooling systems

1.2.1 Cargo temperature control systems

IBC CODE REFERENCE: Ch 7, 7.1.1

Wherever a particular temperature (higher or lower than the ambient temperature) is required to be maintained for the preservation of the cargo, one of the following systems is to be adopted:

- thermal insulated tanks capable of maintaining the temperature of the cargo within acceptable limits for the time of the voyage.
- a heating or cooling plant or refrigerating plant.
- a combination of a) and b) above.

1.2.2 Additional requirements for heating and cooling plants

IBC CODE REFERENCE: Ch 7, 7.1.1

- Manifolds for the delivery and backflow of heating media are to be fitted on the weather deck; connections to cargo tanks for inlet and outlet are to be in way of the cargo tank top.
- Where the heat exchanger room is located in the accommodation area and considered as gas-safe, it is to be treated as a machinery space (not a category A machinery space) and provided with independent mechanical extraction ventilation as well as with scuppers discharging directly into the machinery space.

1.2.3 Reference temperature

IBC CODE REFERENCE: Ch 7, 7.1.1

Wherever the cargo temperature is maintained by a heating or refrigerating plant, unless otherwise indicated in the contract specification, the system is to be designed taking into account the reference temperatures indicated in Tab 1.

Table 1 :

Reference temperature (°C)		
	Heating system	Cooling system
Sea	0	32
Air	5	45

1.2.4 Redundancy

IBC CODE REFERENCE: Ch 7, 7.1.1

Wherever the heating or cooling system is essential for the preservation of the cargo, the following components are to be duplicated:

- a) coils and ducts in cargo tanks
- b) heating or cooling sources
- c) circulating pumps for cargo and heating cooling media; if suitable for the use, cargo pumps may be employed for the circulation of the heating or cooling media
- d) refrigeration plant.

1.2.5 Maximum surface temperature

Depending on the class temperature of the cargoes being carried, the maximum surface temperature of the heating system, within enclosed spaces inside the cargo area should not exceed the values of Tab 2.

Table 2 :

Class temperature	Maximum surface temperature of the heating system
T1	450°C
T2	300°C
T3	200°C
T4	135°C
T5	100°C
T6	85°C

1.3 Valves and other fittings

1.3.1 Means for purging

IBC CODE REFERENCE: Ch 7, 7.1.3

Cargo heating or cooling systems are to be fitted with the necessary connections to purge, by inert gas or compressed air, the heating or cooling circuit of each cargo tank and to perform the pressure testing of the system.

1.4 Cargo temperature measuring system

1.4.1 Alarm

IBC CODE REFERENCE: Ch 7, 7.1.5

- a) An alarm system is required for those products which are carried in a heated condition (see 15.13.6 of the IBC Code) and for which, in column "o" of the tables in Chapter 17 of the IBC Code, reference is made to the requirements of 15.13 of the IBC Code.
- b) An alarm system is required for those products for which a carrying temperature not greater than certain limits is required by Chapter 15 of the IBC Code, such as elementary phosphorus and molten sulphur.
- c) An alarm connection to the navigating bridge and to the cargo control station, if fitted, is to be provided.

1.5 Requirements for special products

1.5.1 Products which may damage the cargo heating or cooling system

IBC CODE REFERENCE: Ch 7, 7.1.6

- a) The provisions of 7.1.6 of the IBC Code also apply to products which may damage the cargo heating or cooling system.
- b) If the sampling equipment mentioned in 7.1.6.3 of the IBC Code consists of an observation tank for drains, this tank is generally to comply with the following requirements:
 - it is to be located in the cargo area and provided with an air pipe with the end fitted with a flame screen, as per the Rules, and arranged at not less than 3 m from openings of accommodation spaces and from sources of ignition
 - it is to be fitted with a connection for discharge into the slop tanks with associated shut-off valves and sight glass and equipped with a sampling cock for backflowing medium analysis.

Section 8 Cargo Tank Venting and Gas-Freeing Arrangements

1 Cargo tank venting

1.1 Venting system drainage

1.1.1 Large amounts of drainage

IBC CODE REFERENCE: Ch 8, 8.2.3

When large amounts of drainage from vent lines of the cargo tanks are envisaged, a hose connection to the drain line of the slop tank is to be provided.

2 Types of tank venting system

2.1 Controlled tank venting system

2.1.1 Tests of pressure/vacuum valves

IBC CODE REFERENCE: Ch. 8, 8.3.2

The tightness and the setting pressure of the cargo tanks pressure/vacuum or pressure- and vacuum-relief valves are to be checked. Inspections and tests for these valves are given in Ch 8, Sec 5, Tab 2.

2.1.2 By-passing of P/V valves

IBC CODE REFERENCE: Ch 8, 8.3.2

By-passing of P/V valves is allowed during cargo operations for cargoes which do not require a vapor return system, provided that the vent-line outlet is fitted with flame arresters and is located at the required height above the deck level. However, by-passing of high-velocity valves is not permitted.

2.1.3 Flame arresters

IBC CODE REFERENCE: Ch. 8, 8.3.5

Inspections and tests for flame arresters are given in Ch 8, Sec 5, Tab 2.

2.2 Position of vent outlets

2.2.1 Outlets from tanks intended for flammable and toxic products

IBC CODE REFERENCE: Ch. 8, 8.3.3

Vent outlets of cargo tanks intended for the carriage of flammable or toxic products are to be arranged at a distance of not less than 3 m from exhaust ducts and as far as possible from inlet ducts to pump rooms and cargo pump rooms.

3 Cargo tank gas-freeing

3.1 Fans

3.1.1

IBC CODE REFERENCE: Ch 8, 8.6

The impellers and housing of either fixed or portable fans fitted in dangerous spaces are to be of non-sparking materials according to 12.1.8 of the IBC Code.

Section 9 Environmental Control

1 General

1.1 Control by padding

1.1.1 Padding medium

IBC CODE REFERENCE: Ch 9, 9.1.3

The padding medium is to be compatible from the point of view of safety with the products to be carried, it is not to react with them and with air and it is to have chemical and physical properties deemed suitable by the Society. The system is to comply with the requirements for inert gas systems, as applicable.

1.2 Control by drying

1.2.1 Simultaneous carriage of incompatible products

IBC CODE REFERENCE: Ch 9, 9.1.4

In the case of simultaneous carriage of mutually incompatible products, dry gas supply piping systems to each cargo space are to be separate from each other.

1.3 Control by inerting

1.3.1 Application

IBC CODE REFERENCE: Ch 9, 9.1

- a) Ships having the service notations **chemical tanker** and of 8 000 tonnes deadweight and upwards, carrying crude oil or petroleum products having a flashpoint not exceeding 60°C (closed cup test), as determined by an approved flashpoint apparatus, and a Reid vapour pressure which is below the atmospheric pressure, or other liquid products having a similar fire hazard, are to be equipped with an inert gas system complying with the requirements of Article [2], or with equivalent systems or arrangements in accordance with items b) and c).
- b) For ships having the service notations **chemical tanker** and of 8 000 tonnes deadweight and upwards and of less than 20,000 tonnes deadweight, the Society may accept other equivalent arrangements in accordance with item a) and item c)
- c) Equivalent systems or arrangements shall:
 - be capable of preventing dangerous accumulation of explosive mixtures in intact cargo tanks during normal service throughout the ballast voyage and necessary in-tank operations, and
 - be so designed as to minimize the risk of ignition from the generation of static electricity by the system itself.

1.3.2 Simultaneous carriage of incompatible products

IBC CODE REFERENCE: Ch 9, 9.1

The inert gas is to comply with the requirements of 9.1.3 of the IBC Code, adapted, to the satisfaction of the Society, to the individual characteristics of the products to be carried. In the case of simultaneous carriage of mutually incompatible products, inert gas supply piping systems to each cargo space are to be separate from each other.

1.3.3 Ships with no fixed inert gas system

IBC CODE REFERENCE: Ch 9, 9.1

Where no fixed installation for inert gas and/or dry gas production is provided for on board, the minimum quantity to be kept on board is established by the Master, based on the duration of the voyage, the anticipated daily temperature variations, gas leakage through cargo tank seals and experience of previous similar cases.

1.3.4 Additional requirements

IBC CODE REFERENCE: Ch 9, 9.1

- a) In addition to the provisions in 9.1.3 of the IBC Code, the inert gas system is to comply with the requirements of Article [2].
- b) These requirements apply where an inert gas system based on Nitrogen or oil fired inert gas generators is fitted on board chemical tankers. Any proposal to use other sources of inert gas will be specially considered.

1.4 Control by ventilation

1.4.1

IBC CODE REFERENCE: Ch 9, 9.1

When a cargo space ventilation system other than the venting system mentioned under 8.2 of the IBC Code is required following these provisions, such system is to be specially examined by the Society.

2 Inert gas systems

2.1 General requirements

2.1.1 The inert gas system is to comply with the applicable requirements of Pt C, Ch 4, Sec 15, [13].

2.1.2 Plans in diagrammatic form are to be submitted for appraisal and are to include the following:

- details and arrangement of inert gas generating plant including all control monitoring devices
- arrangement of piping system for distribution of the inert gas

2.1.3 An automatic control capable of producing suitable inert gas under all service conditions is to be fitted

2.2 Additional requirements for nitrogen generator systems

2.2.1 The following requirements apply where a nitrogen generator system is fitted on board as required by [1.3.1]. For the purpose, the inert gas is to be produced by separating air into its component gases by passing compressed air through a bundle of hollow fibres, semi-permeable membranes or adsorber materials.

2.2.2 In addition to the applicable requirements of Pt C, Ch 4, Sec 15, [13], the nitrogen generator system is to comply with Ch 7, Sec 4, [4.3.2], and Ch 7, Sec 4, [4.2.10].

2.2.3 A nitrogen generator is to consist of a feed air treatment system and any number of membrane or adsorber modules in parallel necessary to meet the requirements of Pt C, Ch 4, Sec 15, [13.2.1], item b) 4).

2.2.4 The nitrogen generator is to be capable of delivering high purity nitrogen in accordance with Pt C, Ch 4, Sec 15, [13.2.1], item b) 5). In addition to Pt C, Ch 4, Sec 15, [13.2.2], item d), the system is to be fitted with automatic means to discharge "off-spec" gas to the atmosphere during start-up and abnormal operation.

2.2.5 The system is to be provided with one or more compressors to generate enough positive pressure to be capable of delivering the total volume of gas required by Pt C, Ch 4, Sec 15, [13.2.1], item b). Where two compressors are provided, the total required capacity of the system is preferably to be divided equally between the two compressors, and in no case is one compressor to have a capacity less than 1/3 of the total capacity required.

2.2.6 The feed air treatment system fitted to remove free water, particles and traces of oil from the compressed air as required by Pt C, Ch 4, Sec 15, [13.4.2], item b), is also to preserve the specification temperature.

2.2.7 The oxygen-enriched air from the nitrogen generator and the nitrogen-product enriched gas from the protective devices of the nitrogen receiver are to be discharged to a safe location on the open deck.

Note 1: "safe location" needs to address the two types of discharges separately:

- oxygen-enriched air from the nitrogen generator - safe locations on the open deck are:
 - outside of hazardous area;
 - not within 3m of areas traversed by personnel; and
 - not within 6m of air intakes for machinery (engines and boilers) and all ventilation inlets
- nitrogen-product enriched gas from the protective devices of the nitrogen receiver - safe locations on the open deck are:
 - not within 3m of areas traversed by personnel; and
 - not within 6m of air intakes for machinery (engines and boilers) and all ventilation inlets/outlets.

2.2.8 In order to permit maintenance, means of isolation are to be fitted between the generator and the receiver.

2.3 Nitrogen /Inert gas systems fitted for purposes other than inerting required by [1.3.1]

2.3.1 Nitrogen/inert gas systems fitted on chemical tankers of less than 8 000 tonnes deadweight and for which an inert gas system is not required by [1.3.1] are to comply with the following requirements.

2.3.2 Requirements of:

- Pt C, Ch 4, Sec 15, [13.2.2], item b)
- Pt C, Ch 4, Sec 15, [13.2.2], item d)
- Pt C, Ch 4, Sec 15, [13.2.4], item b)
- Pt C, Ch 4, Sec 15, [13.2.4], item c)
- Pt C, Ch 4, Sec 15, [13.2.4], item e) 1) regarding oxygen content and power supply to the indicating devices
- Pt C, Ch 4, Sec 15, [13.2.4], item e) 4)
- Pt C, Ch 4, Sec 15, [13.4.2] and
- Pt C, Ch 4, Sec 15, [13.4.3],

apply to the systems.

2.3.3 The requirements of [2.2] apply except requirements [2.2.1] to [2.2.3] and [2.2.5].

2.3.4 The two non-return devices as required by Pt C, Ch 4, Sec 15, [13.2.3], item a) 1) are to be fitted in the inert gas main. The non-return devices are to comply with Pt C, Ch 4, Sec 15, [13.2.3], item a) 2) and Pt C, Ch 4, Sec 15, [13.2.3], item a) 3); however, where the connections to the cargo tanks, to the hold spaces or to cargo piping are not permanent, the non-return devices required by Pt C, Ch 4, Sec 15, [13.2.3], item a) 1) may be substituted by two non-return valves.

Section 10 Electrical Installations

1 General

1.1 Application

1.1.1 The requirements in this Section apply, in addition to those contained in Part C, Chapter 2, to chemical tankers.

1.1.2 The design is to be in accordance with IEC publication 60092-502.

However, where the prescriptive requirements in the present Rules and IEC 60092-502 are not aligned, the prescriptive requirements in the present Rules take precedence and are to be applied.

1.2 Documentation to be submitted

1.2.1 In addition to the documentation requested in Pt C, Ch 2, Sec 1, Tab 1, the following documents are to be submitted for approval:

- a) plan of hazardous areas
- b) document giving details of types of cables and safety characteristics of the equipment installed in hazardous areas
- c) diagrams of tank level indicator systems, high level alarm systems and overflow control systems where requested.

1.3 System of supply

1.3.1 Acceptable systems of supply

The following systems of generation and distribution of electrical energy are acceptable:

- a) direct current:
 - two-wire insulated
- b) alternating current:
 - single-phase, two-wire insulated
 - three-phase, three-wire insulated.

In insulated distribution systems, no current carrying part is to be earthed, other than:

- a) through an insulation level monitoring device
- b) through components used for the suppression of interference in radio circuits.

1.3.2 Earthed system with hull return

Earthed systems with hull return are not permitted, with the following exceptions to the satisfaction of the Society:

- a) impressed current cathodic protective systems
- b) limited and locally earthed systems, such as starting and ignition systems of internal combustion engines, provided that any possible resulting current does not flow directly through any hazardous area
- c) insulation level monitoring devices, provided that the circulation current of the device does not exceed 30 mA under the most unfavourable conditions.

1.3.3 Earthed systems without hull return

Earthed systems without hull return are not permitted, with the following exceptions:

- a) earthed intrinsically safe circuits and the following other systems to the satisfaction of the Society
- b) power supplies, control circuits and instrumentation circuits in non-hazardous areas where technical or safety reasons preclude the use of a system with no connection to earth, provided the current in the hull is limited to not more than 5 A in both normal and fault conditions, or
- c) limited and locally earthed systems, such as power distribution systems in galleys and laundries to be fed through isolating transformers with the secondary windings earthed, provided that any possible resulting hull current does not flow directly through any hazardous area, or
- d) alternating current power networks of 1,000 V root mean square (line to line) and over, provided that any possible resulting current does not flow directly through any hazardous area; to this end, if the distribution system is extended to areas remote from the machinery space, isolating transformers or other adequate means are to be provided.

1.4 Earth detection

1.4.1 Monitoring of circuits in hazardous areas

The devices intended to continuously monitor the insulation level of all distribution systems are also to monitor all circuits, other than intrinsically safe circuits, connected to apparatus in hazardous areas or passing through such areas. An audible and visual alarm is to be given, at a manned position, in the event of an abnormally low level of insulation.

1.5 Mechanical ventilation of hazardous spaces

1.5.1 Electric motors driving fans of the ventilating systems of hazardous spaces are to be located outside the ventilation ducting.

1.5.2 Motors driving ventilating fans may be located within the ducting provided that they are of a certified safe type.

1.5.3 The materials used for the fans and their housing are to be in compliance with Pt C, Ch 4, Sec 1, [3.32].

1.5.4 Cargo pump-rooms and other enclosed spaces which contain cargo-handling equipment and similar spaces in which work is performed on the cargo should be fitted with mechanical ventilation systems, capable of being controlled from outside such spaces.

1.5.5 Provisions are to be made to ventilate the spaces defined in [1.5.4] prior to entering the compartment and operating the equipment.

1.6 Electrical installation precautions

1.6.1 Precautions against corrosion

Where products are liable to damage the materials normally used in electrical apparatuses, special attention is to be paid to the selection of materials for conductors, insulation and metal parts to be installed in gas-dangerous spaces. Copper, aluminium and insulation materials are to be protected as far as possible in order to prevent contact with products and/or their corrosive vapours (e.g. by means of encasing). This provision applies to those products for which the symbol Z is listed in column "m" of the tables in Chapter 17 of the IBC Code.

1.6.2 Precautions against inlet of gases or vapours

Suitable arrangements are to be provided, to the satisfaction of the Society, so as to prevent the possibility of gases or vapours passing from a gas-dangerous space to another space through runs of cables or their conduits.

2 Hazardous locations and types of equipment

2.1 Electrical equipment permitted in hazardous areas for ships carrying dangerous chemicals in bulk having a flash-point not exceeding 60°C and ships carrying dangerous chemicals in bulk having a flash point exceeding 60°C heated to a temperature within 15°C of their flash point or above their flashpoint

2.1.1 In order to facilitate the selection of appropriate electrical apparatus and the design of suitable electrical installations, hazardous areas are divided into zone 0, 1 and 2 according to Pt C, Ch 2, Sec 1, [3.25.3]. The different spaces are to be classified according to Tab 1.

The types of electrical equipment admitted, depending on the zone where they are installed, are specified in Pt C, Ch 2, Sec 3, [10].

2.1.2 A space separated by a gastight boundaries from a hazardous area may be classified as zone 0, 1, 2 or considered as non hazardous, taking into account the sources of release inside that space and its conditions of ventilation.

2.1.3 Access door and other openings are not to be provided between an area intended to be considered as non-hazardous and a hazardous area or between a space intended to be considered as zone 2 and a zone 1, except where required for operational reasons.

2.1.4 In enclosed or semi-enclosed spaces having a direct opening into any hazardous space or area, electrical installations are to comply with the requirements for the space or area to which the opening leads.

2.1.5 Where a space has an opening into an adjacent, more hazardous space or area, it may be made into a less hazardous space or non-hazardous space, taking into account the type of separation and the ventilation system.

2.1.6 A differential pressure monitoring device or a flow monitoring device, or both, are to be provided for monitoring the satisfactory functioning of pressurisation of spaces having an opening into a more hazardous zone.

In the event of loss of the protection by the over-pressure or loss of ventilation in spaces classified as zone 1 or zone 2, protective measures are to be taken.

2.2 Electrical equipment permitted in hazardous areas for ships carrying dangerous chemicals in bulk having a flash-point exceeding 60°C unheated or heated to a temperature below and not within 15°C of their flashpoint

2.2.1 For systems of supply and earth detection, the requirements under Ch 7, Sec 5, [1.3] and Ch 7, Sec 5, [1.4] apply.

2.2.2 Cargo tanks, slop tanks, any pipe work of pressure-relief or other venting systems for cargo and slop tanks, pipes and equipment containing the cargo are to be classified as zone 2.

2.3 Electrical equipment permitted in tankers carrying cargoes (for example acids) reacting with other products/materials to evolve flammable gases

2.3.1 The different spaces are to be classified according to Tab 2.

Table 1 : Space descriptions and hazardous area zones for ships carrying dangerous chemicals in bulk having a flash point not exceeding 60°C and ships carrying dangerous chemicals in bulk having a flash point exceeding 60°C heated to a temperature within 15°C of their flash point or above their flash point

No.	Description of spaces	Hazardous area
1	The interior of cargo tanks, slop tanks, any pipework of pressure-relief or other venting systems for cargo and slop tanks, pipes and equipment containing the cargo or developing flammable gases and vapours	Zone 0
2	Void space adjacent to, above or below integral cargo tanks	Zone 1
3	Hold spaces	Zone 1
4	Cofferdams and permanent (for example, segregated) ballast tanks adjacent to cargo tanks	Zone 1
5	Cargo pump rooms	Zone 1
6	Enclosed or semi-enclosed spaces, immediately above cargo tanks (for example, between decks) or having bulkheads above and in line with cargo tank bulkheads, unless protected by a diagonal plate acceptable to the Society	Zone 1
7	Spaces, other than cofferdam, adjacent to and below the top of a cargo tank (for example, trunks, passageways and hold)	Zone 1
8	Areas on open deck, or semi-enclosed spaces on open deck, within 3 m of any cargo tank outlet, gas or vapour outlet, cargo manifold valve, cargo valve, cargo pipe flange, cargo pump-room ventilation outlets and cargo tank openings for pressure release provided to permit the flow of small volumes of gas or vapour mixtures caused by thermal variation.	Zone 1
9	Areas on open deck, or semi-enclosed spaces on open deck above and in the vicinity of any cargo gas outlet intended for the passage of large volumes of gas or vapour mixture during cargo loading and ballasting or during discharging, within a vertical cylinder of unlimited height and 6 m radius centred upon the centre of the outlet, and within a hemisphere of 6 m radius below the outlet	Zone 1
10	Areas on open deck, or semi-enclosed spaces on open deck, within 1,5 m of cargo pump room entrances, cargo pump room ventilation inlet, openings into cofferdams, or other zone 1 spaces	Zone 1
11	Areas on open deck within spillage coamings surrounding cargo manifold valves and 3 m beyond these, up to a height of 2,4 m above the deck	Zone 1
12	Areas on open deck over the cargo area where structures are restricting the natural ventilation and to the full breadth of the ship plus 3 m fore and aft of the forward-most and aft-most cargo tank bulkhead, up to a height of 2,4 m above the deck	Zone 1
13	Compartments for cargo hoses	Zone 1
14	Enclosed or semi-enclosed spaces in which pipes containing cargoes are located	Zone 1
15	Areas of 1,5 m surrounding a space of zone 1	Zone 2
16	Spaces 4 m beyond the cylinder and 4 m beyond the sphere defined in item 9	Zone 2
17	Fore peak ballast tank not adjacent to cargo tanks, when ballasted with the system serving ballast tanks in the cargo area according to Ch 8, Sec 3, [5.1.3]	Zone 2
18	Areas on open deck extending to the coamings fitted to keep any spills on deck and away from the accommodation and service area and 3 m beyond these up to a height of 2,4 m above the deck	Zone 2
19	Areas on open deck over the cargo area where unrestricted natural ventilation is guaranteed and to the full breadth of the ship plus 3 m fore and aft of the forward-most and aft-most cargo tank bulkhead, up to a height of 2,4 m above the deck surrounding open or semi-enclosed spaces of zone 1	Zone 2
20	Spaces forward of the open deck areas to which reference is made in 12 and 18, below the level of the main deck, and having an opening on to the main deck or at a level less than 0,5 m above the main deck, unless: <ul style="list-style-type: none"> the doors and all openings are in non-hazardous area; and the spaces are mechanically ventilated 	Zone 2

Table 2 : Space descriptions and hazardous area zones in tankers carrying cargoes (for example acids) reacting with other products/materials to evolve flammable gases.

No.	Description of spaces	Hazardous area
1	The interior of cargo tanks, slop tanks, any pipework of pressure-relief or other venting systems for cargo and slop tanks, pipes and equipment containing the cargo or developing flammable gases and vapours.	Zone 1
2	Cargo pump rooms.	Zone 1
3	Compartments for cargo hoses.	Zone 1
4	Areas of 1,5 m surrounding the openings of zone 1 spaces specified above.	Zone 2
5	Void space adjacent to, above or below integral cargo tanks.	Zone 2
6	Hold spaces.	Zone 2
7	Cofferdams and permanent (for example, segregated) ballast tanks adjacent to cargo tanks, fore peak ballast tank when ballasted with the system serving ballast tanks in the cargo area according to Ch 8, Sec 3, [5.1.3]	Zone 2
8	Enclosed or semi-enclosed spaces, immediately above cargo tanks (for example, between decks) or having bulkheads above and in line with cargo tank bulkheads, unless protected by a diagonal plate acceptable to the society.	Zone 2
9	Spaces, other than cofferdam, adjacent to and below the top of a cargo tank (for example, trunks, passageways and hold).	Zone 2
10	Enclosed or semi-enclosed spaces in which pipes containing cargoes are located.	Zone 2
11	Areas on open deck, or semi-enclosed spaces on open deck, within 1,5 m of any cargo tank outlet, gas or vapour outlet, cargo manifold valve, cargo valve, cargo pipe flange, cargo pump-room ventilation outlets, and cargo tank openings for pressure release provided to permit the flow of small volumes of gas or vapour mixtures caused by thermal variation.	Zone 2
12	Areas on open deck within spillage coamings surrounding cargo manifold valves and 1,5 m beyond these, up to a height of 1,5 m above the deck.	Zone 2
13	Areas on open deck, or semi-enclosed spaces on open deck above and in the vicinity of any cargo gas outlet intended for the passage of large volumes of gas or vapour mixture during cargo loading and ballasting or during discharging, within a vertical cylinder of unlimited height and 3 m radius centred upon the centre of the outlet, and within a hemisphere of 3 m radius below the outlet.	Zone 2

Section 11 Fire Protection and Fire Extinction

1 General

1.1 Application

1.1.1 Fire-fighting

IBC CODE REFERENCE: Ch 11, 11.1.1.3 and

IBC CODE REFERENCE: Ch 11.1.1.4

Ships having the service notation **chemical tanker** are to comply with the requirements of:

- Pt C, Ch 4, Sec 6, [1]
- Pt C, Ch 4, Sec 6, [3] and
- Pt C, Ch 4, Sec 6, [4] except Pt C, Ch 4, Sec 6, [4.7]

regardless of the size of the ship.

- Pt C, Ch 4, Sec 6, [4.7] only for ships of 2000 gross tonnage and above.

2 Cargo pump rooms

2.1 Fixed fire-extinguishing systems

2.1.1 Halogenated hydrocarbon system

IBC CODE REFERENCE: Ch 11, 11.2.1.2

With reference to 11.2.1.2 of the IBC Code, it is to be noted that new installations of halogenated hydrocarbon systems have been prohibited on all (new and existing) ships since 1 October 1994.

3 Cargo area

3.1 Temperature of steam and heating media within the cargo area

3.1.1

IBC CODE REFERENCE: Ch 11, 11.3

The maximum temperature of the steam and heating media in the cargo area is to be adjusted to comply with maximum surface temperature in Ch 8, Sec 7, [1.2.5].

3.2 Monitors and foam applicators

3.2.1 Capacity for ships of less than 4000 tonnes deadweight

IBC CODE REFERENCE: Ch 11, 11.3.7

For ships of less than 4000 tonnes deadweight, the minimum required capacity for a monitor is to be not less than 1000 litres/min and the application rate that each monitor is to be capable of supplying is to be at least 10 litres/min per each square metre of the surface to be protected.

3.3 Simultaneous use of foam and water systems

3.3.1 Required number of jets of water

IBC CODE REFERENCE: Ch 11, 11.3.12

The simultaneous use of the minimum required number of jets of water is to be possible, in general, on deck over the full length of the ship, in the accommodation and service spaces, in control spaces and in machinery spaces.

3.4 Portable fire-extinguishing equipment

3.4.1 Capacity of portable fire-extinguishing equipment

IBC CODE REFERENCE: Ch 11, 11.3.14

The capacity of each item of portable fire-extinguishing equipment is to comply with the relevant provisions of the 1974 SOLAS Convention, as amended.

3.5 Ships carrying flammable products

3.5.1 Internal combustion engines

IBC CODE REFERENCE: Ch 11, 11.3.15

Internal combustion engines are not to be installed in cargo pump rooms, in pump rooms and in other spaces adjacent to or located above cargo tanks. However, reciprocating steam engines with a working temperature lower than the temperature stated in [3.1] may be installed in the above-mentioned rooms and spaces.

Section 12 Mechanical Ventilation in the Cargo Area

1 Spaces normally entered during cargo handling operations

1.1 Miscellaneous requirements

1.1.1 Ventilation system stopping

IBC CODE REFERENCE: Ch 12, 12.1

All required ventilation systems are to be capable of being stopped from a position located outside the served spaces and above the weather deck.

1.1.2 Warning notices

IBC CODE REFERENCE: Ch 12, 12.1

In the proximity of entrances to all spaces served by the required mechanical ventilation systems, a clearly visible warning is to be posted requiring such spaces to be adequately ventilated prior to entering and relevant ventilation systems to be kept in operation all the time persons are present in the spaces themselves.

1.1.3 Prevention of dangerous operation of electric motors

IBC CODE REFERENCE: Ch 12, 12.1

A suitable automatic device is to be fitted to prevent operation of electric motors driving cargo pumps and operation of other electrical equipment not of a certified safe type prior to ventilating the spaces where such motors or equipment are located, in order to render them gas-safe (to this end it is pointed out that IEC provisions require at least 10 changes of air based on the volume of the served space).

1.1.4 Prevention of dangerous operation of cargo pumps

IBC CODE REFERENCE: Ch 12, 12.1

An automatic device is to be fitted capable of stopping motors driving cargo pumps and de-energising any other electrical equipment not of a certified safe type in the case of stoppage of ventilation in spaces where such motors and equipment are fitted. This provisions does not apply to motors and other electrical equipment fitted in the engine room.

1.1.5 Alternative to extraction type ventilation systems

IBC CODE REFERENCE: Ch 12, 12.1

As an alternative to ventilation systems of the extraction type, required in [1.1.4], a ventilation system of the positive pressure type may be accepted:

- in the case of cargo pump rooms adjacent to cargo tanks or to other gas-dangerous spaces, or
- where, in adjacent gas-safe spaces, inclusive of spaces containing motors of cargo pumps, an adequate overpressure is kept in relation to the cargo pump rooms themselves.

1.1.6 Location of upper end of inlet ducts

IBC CODE REFERENCE: Ch 12, 12.1

With reference to the requirements of [1.1.5], the upper ends of inlet ducts are generally to be located at a distance not less than 3 m from ventilation ducts and air intakes serving the safe spaces mentioned therein.

1.1.7 Minimum distance between inlet and extraction ducts

IBC CODE REFERENCE: Ch 12, 12.1

With reference to [1.1.6], the upper ends of (inlet and extraction) ventilation ducts serving the same space are to be located at a distance from each other, measured horizontally, of not less than 3 m and, in general, at an adequate height above the weather deck, but in any case not less than 2,4 m. Greater heights are required in 15.17 of the IBC Code.

1.1.8 Upper ends of ventilation ducts in ships carrying materials producing flammable vapours

IBC CODE REFERENCE: Ch 12, 12.1

For flammable products, or for products which may react with the ship's materials producing flammable vapours (such as strong acids), the upper ends of ventilation ducts are to be located at a distance of not less than 3 m from any source of ignition, as per the provisions of Ch 8, Sec 8, [2.2].

1.1.9 Dampers

IBC CODE REFERENCE: Ch 12, 12.1

Ventilation ducts are to be provided with metallic dampers, fitted with the indication "open" and "closed". The dampers are to be located above the weather deck, in a readily accessible position.

1.1.10 Location of electric motors of fans

IBC CODE REFERENCE: Ch 12, 12.1

Electric motors driving fans are to be placed outside the served spaces and outside the ventilation ducts, in a suitable position with respect to the presence of flammable vapours.

1.1.11 Penetration of motor shafts through bulkheads

IBC CODE REFERENCE: Ch 12, 12.1

Runs of shafts of electric motors driving fans through bulkheads or decks of gas-dangerous spaces or through ventilation ducts are to be provided with gas-tight seals, with oil glands or equivalent means, deemed suitable by the Society.

They have to be fitted with temperature sensing devices for bulkhead shaft glands bearings and pump casings. Alarms are to be initiated in the cargo control room or the pump control station.

Means are to be provided to compensate for any misalignment.

Shaft bulkhead lubricating means is to be located outside the cargo pump room. If the shaft bulkhead penetration system includes a bellow, this bellow is to be hydraulically tested at a pressure of at least 3,5 bars before being fitted on board.

1.2 Additional requirements for non-sparking fans

1.2.1 Non-sparking fans

IBC CODE REFERENCE: Ch 12, 12.1

- a) A fan is considered as non-sparking if in both normal and abnormal conditions it is unlikely to produce sparks.
- b) The air gap between the impeller and the casing is to be not less than 0,1 of the shaft diameter in way of the impeller bearing and not less than 2 mm. It need not be more than 13 mm.

1.2.2 Materials for non-sparking fans

IBC CODE REFERENCE: Ch 12, 12.1

- a) The impeller and the housing in way of the impeller are to be made of alloys which are recognised as being spark proof by appropriate tests.
- b) Electrostatic charges in both the rotating body and the casing are to be prevented by the use of antistatic materials. Furthermore, the installation on board of the ventilation units is to be such as to ensure their safe bonding to the hull.
- c) Tests may not be required for fans having the following combinations:
 - impellers and/or housings of non-metallic material, due regard being paid to the elimination of static electricity
 - impellers and housings of non-ferrous materials
 - impellers of aluminium alloys or magnesium alloys and a ferrous (including austenitic stainless steel) housing on which a ring of suitable thickness of non-ferrous materials is fitted in way of the impeller
 - any combination of ferrous (including austenitic stainless steel) impellers and housings with not less than 13 mm design tip clearance.
- d) The following impellers and housings are considered as sparking and are not permitted:
 - impellers of an aluminium alloy or magnesium alloy and a ferrous housing, regardless of tip clearance
 - housing made of an aluminium alloy or a magnesium alloy and a ferrous impeller, regardless of tip clearance
 - any combination of ferrous impeller and housing with less than 13 mm design tip clearance.

1.2.3 Type test for non-sparking fans

IBC CODE REFERENCE: Ch 12, 12.1

Type tests on the finished product are to be carried out in accordance with the requirements of the Society.

2 Pump rooms and other enclosed spaces normally entered

2.1 Clarification of general requirement

2.1.1

IBC CODE REFERENCE: Ch 12, 12.2

- a) The provisions of 12.2 of the IBC Code apply to all pump rooms, whether or not the control for pumps and valves which are installed in such rooms is fitted externally.
- b) The distance of the upper ends of extraction and inlet ducts from air intakes and other openings of spaces mentioned in 12.1.5 of the IBC Code is not to be less than 3 m measured horizontally. These systems are to be capable of being controlled from outside the spaces they serve and, in the proximity of the entrances to such spaces, the warning notice mentioned in [1.1.2] is to be posted.

3 Spaces not normally entered

3.1 Portable fans

3.1.1

IBC CODE REFERENCE: Ch 12, 12.3

The type of portable fans and their connections to spaces to be ventilated are to be deemed suitable by the Society. Portable fans driven by electric or internal combustion motors are not acceptable.

Section 13 Instrumentation

1 Gauging

1.1 Types of gauging devices

1.1.1 Arrangement

IBC CODE REFERENCE: Ch 13, 13.1.1

- a) In almost all cases a cargo code which requires a high level alarm and overflow control also requires a closed gauging device. A cargo tank containing such a product therefore requires three sensors:
 - 1) one level gauging
 - 2) one high level alarm
 - 3) one overflow control.
- b) The sensing elements for 1), 2) and 3) are to be separated, although sensors for 2) and 3) (reed switches, float chambers, electronic devices, etc.) may be contained in the same tube.
- c) Electronic, pneumatic and hydraulic circuits required for sensors 1), 2) and 3) are to be independent of each other such that a fault on any one will not render either of the others inoperative.
- d) Where processing units are used to give digital or visual indication, such as in a bridge space, the independence of circuitry is to be maintained at least beyond this point.
- e) The power is to be supplied from distribution boards.
- f) Where a control room or a bridge space containing a modular unit is envisaged, separate level indication and visual alarms are to be provided for each of the functions 1), 2) and 3). An audible alarm is also to be provided but since this is not directional it need not be separate.
- g) An audible alarm is also to be arranged in the cargo area.
- h) Where there is no control room, an audible and visual alarm is to be arranged at the cargo control station.
- i) Testing of sensors is to be arranged from outside the tanks, although entry into product clean tanks is not precluded.
- j) Simulation testing of electronic circuits or circuits which are self-monitored is acceptable.

1.1.2 Example of restricted gauging device

IBC CODE REFERENCE: Ch 13, 13.1.1

A restricted gauging device may consist of a sounding pipe with an inside diameter not greater than 200 mm, fitted with a gas-tight plug. The pipe is to have holes in order to make its internal pressure equal to that of the tank. Therefore the holes are to be located inside the cargo tank in the proximity of the top.

2 Vapour detection

2.1 Vapour detection instruments

2.1.1 Spaces to be monitored

IBC CODE REFERENCE: Ch 13, 13.2.1

Vapour detection instruments, either fixed or portable, are to be of a type recognised suitable by the Society for the products to be carried. The spaces to be monitored are:

- cargo pump rooms
- spaces containing motors driving cargo pumps, except for the machinery space
- enclosed spaces containing cargo piping, equipment connected with cargo handling, cofferdams, enclosed spaces and double bottoms adjacent to cargo tanks
- pipe tunnels
- other spaces, in the opinion of the Society, depending on the ship type.

Where a fixed system is installed, it is to serve the spaces among those listed above which are normally entered by the crew.

2.2 Provisions for installation of gas analysing units

2.2.1 Gas analysing units are to be in compliance with the requirements in Ch 7, Sec 6, [7.4].

Section 14 Protection of Personnel

1 Protective equipment

1.1 Location of protective equipment

1.1.1

IBC CODE REFERENCE: Ch 14, 14.1.2

- a) Lockers for work clothes or protective equipment which are not new or have not undergone a thorough cleaning process are not to open directly into accommodation spaces.
- b) When a locker for clothes which have not undergone a thorough cleaning process is arranged in the accommodation area, it is to be bounded by "A-0" bulkheads and decks and provided with independent exhaust mechanical ventilation. The access to accommodation spaces, if allowed, is to be arranged through two substantially gas-tight self-closing steel doors without any hold-back device.

2 Safety equipment

2.1 Additional equipment for ships carrying toxic products

2.1.1

IBC CODE REFERENCE: Ch 14, 14.2.4

With regard to 14.2.4 of the IBC Code, the equivalent quantity of spare bottled air in lieu of the low pressure air line is to be at least 4800 litres.

2.2 Medical first aid equipment

2.2.1

IBC CODE REFERENCE: Ch 14, 14.2.9

First aid equipment, whose preservation in good condition is the Master's responsibility, is to be kept in a special, clearly indicated locker.

Section 15 Special Requirements

1 Ammonium nitrate solution (93% or less)

1.1 Ammonia injection

1.1.1 Injection procedure

IBC CODE REFERENCE: Ch 15, 15.2.6

Gaseous ammonia may be injected into the cargo while the latter is circulated by the cargo pump.

1.2 Cargo pumps

1.2.1 Seal

IBC CODE REFERENCE: Ch 15, 15.2.7

The seal for the centrifugal pump is to be a stuffing box provided with a lantern ring. Fresh water under pressure is to be injected into the stuffing box at the location of the lantern ring (see Fig 1).

Figure 1 : Seal

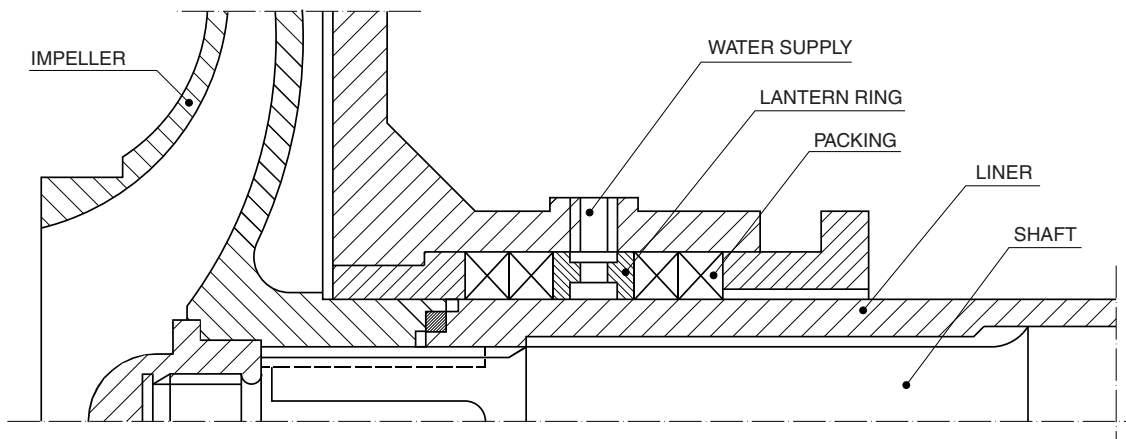

2 Hydrogen peroxide solutions

2.1 Hydrogen peroxide solutions over 60% but not over 70%

2.1.1 Water spray system

IBC CODE REFERENCE: Ch 15, 15.5.10

It is specified that, for the purpose of evaluating the estimated size of the cargo spill in the case of failure, cargo piping/hose failure is to be assumed to be total.

3 Propylene oxide and mixtures of ethylene oxide/propylene oxide with an ethylene oxide content of not more than 30% by weight

3.1 Tank cleaning

3.1.1

IBC CODE REFERENCE: Ch 15, 15.8.3

Until an amendment in this respect is prepared at IMO, it is specified that the initial wording of the text of 15.8.3 of the IBC Code "Before carrying these products," is to be intended as follows: "Before initial loading of these products and before each loading of these products subsequent to loading of other products".

3.2 Joints in cargo lines

3.2.1

IBC CODE REFERENCE: Ch 15, 15.8.12

Screwed connections are only allowed for accessory and instrumental lines with an external diameter of 25 mm or less.

3.3 Oxygen content in tank vapour spaces

3.3.1 Analysing equipment

IBC CODE REFERENCE: Ch 15, 15.8.28

Analysing equipment to determine oxygen and propylene oxide contents is to be of a type recognised as suitable by the Society. When portable analysers are used, there are to be at least two. When a fixed system is installed, a portable analyser is also to be provided.

3.4 Valves at cargo hose connections

3.4.1 Shut-off valve closing time

IBC CODE REFERENCE: Ch 15, 15.8.30

The closing time of shut-off valves provided at each cargo hose connection is to take account of the loading/unloading rate and is to be such as to avoid dangerous overpressure in cargo piping and hoses mentioned in the paragraphs

4 Acids

4.1 Electrical arrangements

4.1.1

IBC CODE REFERENCE: Ch 15, 15.11.5

In enclosed spaces adjacent to cargo tanks, electrical materials and equipment complying with the provisions of 10.1.2.1 of the IBC Code are allowed.

4.2 Leak detection system

4.2.1 Electrical equipment

IBC CODE REFERENCE: Ch 15, 15.11.5

Hazardous areas are to be defined as per Ch 8, Sec 10, Tab 2. Electrical materials and equipment are to have minimum explosion group IIC or IIB+H2 and temperature class T1.

4.3 Lining for tanks and piping

4.3.1 Lining approved for use with acids

IBC CODE REFERENCE: Ch 15, 15.11.2

“Lining” is an acid-resistant material that is applied to the tank or piping system in a solid state i.e. not spray on.

The requirement for the elasticity of a lining to be not less than the supporting boundary plating is to prevent debonding at the interface between the lining and the lined surface.

5 Toxic products

5.1 Return line to shore installation

5.1.1 Valving on connection to shore installation

IBC CODE REFERENCE: Ch 15, 15.12.2

The above-mentioned systems are to be fitted with a shut-off valve and a blank flange in way of the vapour return line to the shore installation.

6 Cargoes protected by additives

6.1 Prevention of blockage by polymerisation

6.1.1 Arrangements

IBC CODE REFERENCE: Ch 15, 13.6

In addition to being designed so as to avoid internal obstructions due to polymer formation, the above-mentioned systems are to be fitted with pressure/vacuum valves and devices to prevent the passage of flame which are accessible for inspection and maintenance.

7 Cargoes with a vapour pressure greater than 0,1013 MPa (1,013 bar) absolute at 37,8°C

7.1 General

7.1.1 System for maintaining cargo temperature below boiling point

IBC CODE REFERENCE: Ch 15, 15.14.1

- a) Any system installed for the purpose of keeping the cargo temperature below its boiling point is to be constructed to the satisfaction of the Society.
- b) Whenever cargo tanks are designed specifically for the carriage of products dealt with in 15.7 of the IBC Code, they are to be capable of withstanding the vapour pressure of such products corresponding to 45°C.

7.2 Return of expelled gases

7.2.1 Valving of shore connection

IBC CODE REFERENCE: Ch 15, 15.14.4

The above-mentioned systems are to be fitted with a shut-off valve and a blank flange in way of the vapour return line to the shore installation.

8 Special cargo pump room requirements

8.1 Clarification

8.1.1

IBC CODE REFERENCE: Ch 15, 15.18

As far as concerns the possibility of allowing the arrangement of cargo pump rooms below deck in specific cases, it is specified that, in practice, no circumstance can be foreseen where such an arrangement may be permitted.

9 Overflow control

9.1 Independence of systems

9.1.1 Gauging devices

IBC CODE REFERENCE: Ch 15, 15.19

In almost all cases where, for the carriage of a product, a cargo high level alarm or cargo overflow control is required, a closed gauging device is also required.

9.1.2 Separation of device sensing elements

IBC CODE REFERENCE: Ch 15, 15.19

A cargo tank intended to carry such a product therefore requires:

- a) level gauging
- b) high level alarm
- c) overflow control.

The sensing elements for the devices under a), b) and c) are to be separated, although sensors for b) and c) (micro-switches, float chambers, electronic devices, etc.) may be contained in the same metal tube sections.

9.1.3 Electronic and hydraulic circuits for sensors

IBC CODE REFERENCE: Ch 15, 15.19

Electronic, pneumatic and hydraulic circuits required for sensors for a), b) and c) are to be independent of each other such that a fault on any one of them will not render either of the others inoperative. Where processing units are used to give digital or visual indication such as in a bridge space, the independence of circuitry is to be maintained at least up to such units. The power is to be supplied from distribution boards.

9.1.4 Alarms in cargo control room

IBC CODE REFERENCE: Ch 15, 15.19

Where a cargo control room or a bridge space containing a modular unit is envisaged, separate level indications and visual alarms are to be provided for each of the functions a), b) and c). An audible alarm is also to be provided; there need not be a separate alarm for each function since separate alarms could not be distinguished. An audible alarm is also to be arranged in the cargo area.

9.1.5 Alarms where cargo control room is not provided

IBC CODE REFERENCE: Ch 15, 15.19

- a) Where no cargo control room is provided, an audible and visual alarm is to be arranged at the cargo control station, which generally coincides with the navigating bridge.
- b) The audible and visual high level and cargo overflow alarms are to be located so as to be easily heard and noticed by the personnel in charge of loading/unloading operations. Attention is drawn to the fact that such alarms are generally grouped together into two independent signals; therefore it is not possible to single out directly the cargo tank from which the alarm signal is coming. In such cases, the Master is to arrange for a person to be present at the cargo control station, in order to be able to warn the personnel in charge of loading operations on deck.

9.1.6 Testing of sensors

IBC CODE REFERENCE: Ch 15, 15.19

Testing of sensors is to be arranged from outside the tanks, although entry into product clean tanks is not prohibited. Simulation testing of electronic circuits or circuits which are self-monitoring is acceptable.

Section 16 Operational Requirements

1 General

1.1

1.1.1 This Section is void, as the provisions of Chapter 16 of the IBC Code are operating requirements which are not mandatory for the class.

Section 17 Summary of Minimum Requirements

1 General

1.1

1.1.1 The list of products and the minimum requirements referred to elsewhere in this Section is the one of Chapter 17 of the IBC code.

Section 18 List of Chemicals to which this Chapter Does Not Apply

1 General

1.1

1.1.1 This Section is void, as there are no additional or alternative requirements to those indicated in Chapter 18 of the IBC Code.

Section 19 Index of Products Carried In Bulk

1 General

1.1

1.1.1 This Section is void, as there are no additional or alternative requirements to those indicated in Chapter 19 of the IBC Code.

Section 20 Transport of Liquid Chemical Wastes

1 General

1.1

1.1.1 This Section is void, as there are no additional or alternative requirements to those indicated in Chapter 20 of the IBC Code.

Section 21 Criteria for Assigning Carriage Requirements for Products Subject to the IBC Code

1 General

1.1

1.1.1 This Section is void, as there are no additional or alternative requirements to those indicated in Chapter 21 of the IBC Code.

Part D

Service Notations

CHAPTER 9

LIQUEFIED GAS CARRIERS

Section 1	General
Section 2	Ship Survival Capability and Location of Cargo Tanks
Section 3	Ship Arrangements
Section 4	Cargo Containment
Section 5	Process Pressure Vessels and Liquid, Vapour and Pressure Piping Systems
Section 6	Materials of Construction and Quality Control
Section 7	Cargo Pressure / Temperature Control
Section 8	Vent Systems for Cargo Containment
Section 9	Cargo Containment System Atmosphere Control
Section 10	Electrical Installations
Section 11	Fire Protection and Extinction
Section 12	Artificial Ventilation in the Cargo Area
Section 13	Instrumentation and Automation Systems
Section 14	Personnel Protection
Section 15	Filling Limits for Cargo Tanks
Section 16	Use of Cargo as Fuel
Section 17	Special Requirements
Section 18	Operating Requirements
Section 19	Summary of Minimum Requirements
Section 20	Hull Scantling
Appendix 1	Guidance for Calculation of Pressures and Accelerations
Appendix 2	Correspondances between Part D, Chapter 9 and the IGC Code

Section 1 General

1 General

1.1 Application

1.1.1 Ships complying with the requirements of this Chapter are eligible for the assignment of the service notation **liquefied gas carrier**, in accordance with Pt A, Ch 1, Sec 2, [4.4.5].

Note 1: The service notation is to be completed by the additional service feature, as defined in Pt A, Ch 1, Sec 2, [4.4.5], indicating the cargo type, the IMO code ship type, the cargo tank design pressure P_{design} and minimum temperature T_{min} .

1.1.2 Ships which are intended for the carriage of liquefied gases are to comply with the requirements of the latest version of the International Code for the Construction and Equipment of Ships Carrying Liquefied Gases in Bulk (IGC Code), as amended.

1.1.3 This Chapter and the IGC Code refer to ships carrying products which are listed in the table in Chapter 19 of the IGC Code and in Ch 9, Sec 19.

1.1.4 This Chapter and the IGC Code include requirements for the carriage of cargo in containment systems incorporating integral, membrane or independent tank types as detailed in Chapter 4 of the IGC Code and in Ch 9, Sec 4.

1.1.5 In general, this Chapter applies to cargo containment and handling systems and to the interfaces between these systems and the remainder of the ship, which is to comply with the additional applicable requirements indicated in Tab 1.

Table 1 : Additional applicable requirements

Item	Reference
Ship arrangement	Part B
Hull	Part B
Stability	Part B
Machinery and cargo system	Part C
Electrical installations:	Part C
Automation	Part C
Fire protection, detection and extinction	Part C

1.1.6 Additional service features for ships using their cargo or other low-flashpoint gaseous fuels

The additional service features **LNGfuel**, **CNGfuel** or **LPGfuel** or, as relevant, other additional service features defined in Pt A, Ch 1, Sec 2, [4.13], may be assigned to **liquefied gas carriers** designed and equipped to use:

- their cargoes as fuel and complying with the requirements of Ch 9, Sec 16 or
- other low-flashpoint gaseous fuels provided that the fuel storage and distribution systems design and arrangements for such gaseous fuels comply with the requirements of the present chapter for gas as a cargo.

The above additional service feature are completed with **singlefuel** when the propulsion system uses only gas as fuel or **dualfuel** when the propulsion system uses both gas and fuel oil as fuel.

1.2 IGC Code requirements and the Society's Rules

1.2.1 General

- For ships having the service notation **liquefied gas carrier**, the IGC Code requirements are to be considered as rule requirements, unless otherwise specified, and with the exception indicated in [1.2.2].
- The rule requirements of this Chapter include:
 - requirements of the IGC Code
 - additional requirements to the IGC Code
 - Society's interpretations of the IGC Code.
- Requirements of IGC Code, specified in the text, *printed in Italic type*; in reproducing the above text in this Chapter applicable for the purpose of classification, the word "Administration", wherever mentioned, has been replaced by the word "Society".
- The correspondence between the references of the IGC Code and those of the present Chapter are given in App 2.

1.2.2 IGC Code requirements not within the scope of classification

The following requirements of the IGC Code are not within the scope of classification:

- Chapter 1, Section 1.3 - Equivalents
- Chapter 1, Section 1.4 - Surveys and certification
- Chapter 18 - Operating requirements.

These requirements are applied by the Society when acting on behalf of the flag Administration, within the scope of delegation (see [1.2.5]).

1.2.3 Carriage of products not listed in the Code

The requirements of the IGC Code and the additional requirements of this Chapter are also applicable to new products, which may be considered to come within the scope of this Chapter, but are not at present listed in the table in Chapter 19 of the IGC Code.

1.2.4 Particularly hazardous products

For the carriage in bulk of products which are not listed in the table in Chapter 19 of the IGC Code, presenting more severe hazards than those covered by the IGC Code, the Society reserves the right to establish requirements and/or conditions additional to those contained in this Chapter.

1.2.5 Certificate of fitness

- a) The responsibility for interpretation of the IGC Code requirements for the purpose of issuing an International Certificate of Fitness for the Carriage of Liquefied Gases in Bulk lies with the Administration of the state whose flag the ship is entitled to fly.
- b) Whenever the Society is authorised by an Administration to issue on its behalf the "Certificate of Fitness for the Carriage of Liquefied Gases in Bulk", or where the Society is authorised to carry out investigations and surveys on behalf of an Administration on the basis of which the "Certificate of Fitness for the Carriage of Liquefied Gases in Bulk" will be issued by the Administration, or where the Society is requested to certify compliance with the IGC Code, the full compliance with the requirements of the IGC Code, including the operative requirements mentioned in [1.2.2], is to be granted by the Society.

2 Application and implementation

2.1

2.1.1 *When cargo tanks contain products for which the Code requires a type 1G ship, neither flammable liquids having a flashpoint of 60°C (closed cup test) or less, nor flammable products listed in Ch 9, Sec 19, shall be carried in tanks located within the protective zones described in Ch 9, Sec 2, [4.1.1], item a).*

2.1.2 *Similarly, when cargo tanks contain products for which the Code requires a type 2G/2PG ship, the flammable liquids as described in [2.1.1], shall not be carried in tanks located within the protective zones described in Ch 9, Sec 2, [4.1.1], item b).*

2.1.3 *In each case, for cargo tanks loaded with products for which the Code requires a type 1G or 2G/2PG ship, the restriction applies to the protective zones within the longitudinal extent of the hold spaces for those tanks.*

2.1.4 *The flammable liquids and products described in [2.1.1] may be carried within these protective zones when the quantity of products retained in the cargo tanks, for which the Code requires a type 1G or 2G/2PG ship is solely used for cooling, circulation or fuelling purposes.*

2.1.5 *Except as provided in [2.1.6], when it is intended to carry products covered by this Code and products covered by the International Code for the Construction and Equipment of Ships Carrying Dangerous Chemicals in Bulk (IBC Code), adopted by IMO resolution MSC.4(48), as amended, the ship shall comply with the requirements of both Codes appropriate to the products carried.*

2.1.6 *The requirements of this Code shall take precedence when a ship is designed and constructed for the carriage of the following products:*

- a) *those listed exclusively in Ch 9, Sec 19, and*
- b) *one or more of the products that are listed both in the Code and in the International Bulk Chemical Code. These products are marked with (1) in Ch 9, Sec 19, Tab 1, column "Product name".*

2.1.7 *When a ship is intended to exclusively carry one or more of the products referred to in [2.1.6], item a) the requirements of the International Bulk Chemical Code, as amended, shall apply.*

2.1.8 *The ship's compliance with the requirements of the International Gas Carrier Code shall be shown by its International Certificate of Fitness for the Carriage of Liquefied Gases in Bulk. Compliance with the amendments to the Code, as appropriate, shall also be indicated in the International Certificate of Fitness for the Carriage of Liquefied Gases in Bulk.*

2.1.9 *Where reference is made in the Code to a paragraph, all the provisions of the subparagraph of that designation shall apply.*

2.1.10 When a ship is intended to operate for periods at a fixed location in a re-gasification and gas discharge mode or a gas receiving, processing, liquefaction and storage mode, the Society and port Administrations involved in the operation shall take appropriate steps to ensure implementation of the provisions of the Code as are applicable to the proposed arrangements. Furthermore, additional requirements shall be established based on the principles of the Code as well as recognized standards that address specific risks not envisaged by it. Such risks may include, but not be limited to:

- fire and explosion
- evacuation
- extension of hazardous areas
- pressurized gas discharge to shore
- high-pressure gas venting
- process upset conditions
- storage and handling of flammable refrigerants
- continuous presence of liquid and vapour cargo outside the cargo containment system
- tank over-pressure and under-pressure
- ship-to-ship transfer of liquid cargo, and
- collision risk during berthing manoeuvres.

2.1.11 Where a risk assessment or study of similar intent is utilized within the Code, the results shall also include, but not be limited to, the following as evidence of effectiveness:

- description of methodology and standards applied
- potential variation in scenario interpretation or sources of error in the study
- validation of the risk assessment process by an independent and suitable third party
- quality system under which the risk assessment was developed
- the source, suitability and validity of data used within the assessment
- the knowledge base of persons involved within the assessment
- system of distribution of results to relevant parties, and
- validation of results by an independent and suitable third party.

2.1.12 Although the Code is legally treated as a mandatory instrument under the SOLAS Convention, the provisions of Ch 9, App 1, [1] and Appendices 1, 3 and 4 of IGC code are recommendatory or informative.

3 Additional requirements

3.1 Emergency towing arrangement

3.1.1 Emergency towing arrangements are to be fitted on liquefied gas tankers of 20.000 dwt and above in accordance with Pt B, Ch 12, Sec 4, [3].

3.2 Steering gear

3.2.1 Additional requirements for steering gear of liquefied gas carriers of 10.000 dwt and above are given in Ch 7, Sec 4, [7].

4 Definitions

4.1

4.1.1 Except where expressly provided otherwise, the following definitions apply to the Code. Additional definitions are provided throughout the Code.

4.1.2 Accommodation spaces are those spaces used for public spaces, corridors, lavatories, cabins, offices, hospitals, cinemas, games and hobby rooms, barber shops, pantries without cooking appliances and similar spaces.

4.1.3 "A" class divisions are divisions as defined in regulation II-2/3.2 of the SOLAS Convention.

4.1.4 Administration means the Government of the State whose flag the ship is entitled to fly. For Administration (port), see port Administration.

4.1.5 Anniversary date means the day and the month of each year that will correspond to the date of expiry of the International Certificate of Fitness for the Carriage of Liquefied Gases in Bulk.

4.1.6 Boiling point is the temperature at which a product exhibits a vapour pressure equal to the atmospheric pressure.

4.1.7 *Breadth (B) means the maximum breadth of the ship, measured amidships to the moulded line of the frame in a ship with a metal shell, and to the outer surface of the hull in a ship with a shell of any other material. The breadth (B) shall be measured in metres.*

4.1.8 *Cargo area is that part of the ship which contains the cargo containment system and cargo pump and compressor rooms and includes the deck areas over the full length and breadth of the part of the ship over these spaces. Where fitted, the cofferdams, ballast or void spaces at the after end of the aftermost hold space or at the forward end of the foremost hold space are excluded from the cargo area.*

4.1.9 *Cargo containment system is the arrangement for containment of cargo including, where fitted, a primary and secondary barrier, associated insulation and any intervening spaces, and adjacent structure, if necessary, for the support of these elements. If the secondary barrier is part of the hull structure, it may be a boundary of the hold space.*

4.1.10 *Cargo control room is a space used in the control of cargo handling operations.*

4.1.11 *Cargo machinery spaces are the spaces where cargo compressors or pumps, cargo processing units, are located, including those supplying gas fuel to the engine-room.*

4.1.12 *Cargo pumps are pumps used for the transfer of liquid cargo including main pumps, booster pumps, spray pumps, etc.*

4.1.13 *Cargoes are products listed in Ch 9, Sec 19, that are carried in bulk by ships subject to the Code.*

4.1.14 *Cargo service spaces are spaces within the cargo area, used for workshops, lockers and store-rooms that are of more than 2 m² in area.*

4.1.15 *Cargo tank is the liquid-tight shell designed to be the primary container of the cargo and includes all such containment systems whether or not they are associated with the insulation or/and the secondary barriers.*

4.1.16 *Closed loop sampling is a cargo sampling system that minimizes the escape of cargo vapour to the atmosphere by returning product to the cargo tank during sampling.*

4.1.17 *Cofferdam is the isolating space between two adjacent steel bulkheads or decks. This space may be a void space or a ballast space.*

4.1.18 *Control stations are those spaces in which ship's radio, main navigating equipment or the emergency source of power is located or where the fire-recording or fire control equipment is centralized. This does not include special fire control equipment, which can be most practically located in the cargo area.*

4.1.19 *Flammable products are those identified by an "F" in Ch 9, Sec 19, Tab 1, column "Vapour detection".*

4.1.20 *Flammability limits are the conditions defining the state of fuel-oxidant mixture at which application of an adequately strong external ignition source is only just capable of producing flammability in a given test apparatus.*

4.1.21 *Gas carrier is a cargo ship constructed or adapted and used for the carriage in bulk of any liquefied gas or other products listed in Ch 9, Sec 19, Tab 1.*

4.1.22 *Gas combustion unit (GCU) is a means of disposing excess cargo vapour by thermal oxidation.*

4.1.23 *Gas consumer is any unit within the ship using cargo vapour as a fuel.*

4.1.24 *Hazardous area is an area in which an explosive gas atmosphere is, or may be expected to be present, in quantities that require special precautions for the construction, installation and use of electrical equipment. When a gas atmosphere is present, the following hazards may also be present: toxicity, asphyxiation, corrosivity, reactivity and low temperature. These hazards shall also be taken into account and additional precautions for the ventilation of spaces and protection of the crew will need to be considered. Examples of hazardous areas include, but are not limited to, the following:*

- *the interiors of cargo containment systems and any pipework of pressure-relief or other venting systems for cargo tanks, pipes and equipment containing the cargo*
- *interbarrier spaces*
- *hold spaces where the cargo containment system requires a secondary barrier*
- *hold spaces where the cargo containment system does not require a secondary barrier*
- *space separated from a hold space by a single gastight steel boundary where the cargo containment system requires a secondary barrier*
- *cargo machinery spaces*
- *areas on open deck, or semi-enclosed spaces on open deck, within 3 m of possible sources of gas release, such as cargo valve, cargo pipe flange, cargo machinery space ventilation outlet, etc.*
- *areas on open deck, or semi-enclosed spaces on open deck within 1,5 m of cargo machinery space entrances, cargo machinery space ventilation inlets*

- areas on open deck over the cargo area and 3 m forward and aft of the cargo area on the open deck up to a height of 2,4 m above the weather deck
- an area within 2,4 m of the outer surface of a cargo containment system where such surface is exposed to the weather
- enclosed or semi-enclosed spaces in which pipes containing cargoes are located, except those where pipes containing cargo products for boil-off gas fuel burning systems are located
- an enclosed or semi-enclosed space having a direct opening into any hazardous area
- void spaces, cofferdams, trunks, passageways and enclosed or semi-enclosed spaces, adjacent to, or immediately above or below, the cargo containment system
- areas on open deck or semi-enclosed spaces on open deck above and in the vicinity of any vent riser outlet, within a vertical cylinder of unlimited height and 6 m radius centred upon the centre of the outlet and within a hemisphere of 6 m radius below the outlet, and
- areas on open deck within spillage containment surrounding cargo manifold valves and 3 m beyond these up to a height of 2,4 m above deck.

Note 1: Refer to Ch 9, Sec 10 for a separate list of examples and classification of hazardous areas for the purpose of selection and design of electrical installations.

4.1.25 Non-hazardous area is an area other than a hazardous area.

4.1.26 Hold space is the space enclosed by the ship's structure in which a cargo containment system is situated.

4.1.27 IBC Code means the International Code for the Construction and Equipment of Ships carrying Dangerous Chemicals in Bulk, adopted by the Maritime Safety Committee of the Organization by resolution MSC.4(48), as amended.

4.1.28 Independent means that a piping or venting system, for example, is in no way connected to another system and that there are no provisions available for the potential connection to other systems.

4.1.29 Insulation space is the space, which may or may not be an interbarrier space, occupied wholly or in part by insulation.

4.1.30 Interbarrier space is the space between a primary and a secondary barrier, whether or not completely or partially occupied by insulation or other material.

4.1.31 Length (*L*) is the length as defined in the International Convention on Load Lines in force.

4.1.32 Machinery spaces of category A are those spaces, and trunks to those spaces, which contain either:

- internal combustion machinery used for main propulsion, or
internal combustion machinery used for purposes other than main propulsion where such machinery has, in the aggregate, a total power output of not less than 375 kW, or
- any oil-fired boiler or oil fuel unit or any oil-fired equipment other than boilers, such as inert gas generators, incinerators, etc.

4.1.33 Machinery spaces are machinery spaces of category A and other spaces containing propelling machinery, boilers, oil fuel units, steam and internal-combustion engines, generators and major electrical machinery, oil filling stations, refrigerating, stabilizing, ventilation and air-conditioning machinery, and similar spaces and the trunks to such spaces.

4.1.34 MARVS is the maximum allowable relief valve setting of a cargo tank (gauge pressure).

4.1.35 Nominated surveyor is a surveyor nominated/appointed by an Administration to enforce the provisions of the SOLAS Convention regulations with regard to inspections and surveys and the granting of exemptions therefrom.

4.1.36 Oil fuel unit is the equipment used for the preparation of oil fuel for delivery to an oil-fired boiler, or equipment used for the preparation for delivery of heated oil to an internal combustion engine, and includes any oil pressure pumps, filters and heaters dealing with oil at a pressure of more than 0,18 MPa gauge.

4.1.37 Organization is the International Maritime Organization (IMO).

4.1.38 Permeability of a space means the ratio of the volume within that space which is assumed to be occupied by water to the total volume of that space.

4.1.39 Port Administration means the appropriate authority of the country for the port where the ship is loading or unloading.

4.1.40 Primary barrier is the inner element designed to contain the cargo when the cargo containment system includes two boundaries.

4.1.41 Products is the collective term used to cover the list of gases indicated in chapter 19 of this Code.

4.1.42 Public spaces are those portions of the accommodation that are used for halls, dining rooms, lounges and similar permanently enclosed spaces.

4.1.43 Relative density is the ratio of the mass of a volume of a product to the mass of an equal volume of fresh water.

4.1.44 Secondary barrier is the liquid-resisting outer element of a cargo containment system, designed to afford temporary containment of any envisaged leakage of liquid cargo through the primary barrier and to prevent the lowering of the temperature of the ship's structure to an unsafe level. Types of secondary barrier are more fully defined in Ch 9, Sec 4.

4.1.45 Separate systems are those cargo piping and vent systems that are not permanently connected to each other.

4.1.46 Service spaces are those used for galleys, pantries containing cooking appliances, lockers, mail and specie rooms, store-rooms, workshops other than those forming part of the machinery spaces, and similar spaces and trunks to such spaces.

4.1.47 SOLAS Convention means the International Convention for the Safety of Life at Sea, 1974, as amended.

4.1.48 Tank cover is the protective structure intended to either protect the cargo containment system against damage where it protrudes through the weather deck or to ensure the continuity and integrity of the deck structure.

4.1.49 Tank dome is the upward extension of a portion of a cargo tank. In the case of below-deck cargo containment systems, the tank dome protrudes through the weather deck or through a tank cover

4.1.50 Thermal oxidation method means a system where the boil-off vapours are utilized as fuel for shipboard use or as a waste heat system subject to the provisions of chapter 16 or a system not using the gas as fuel complying with this Code.

4.1.51 Toxic products are those defined by a "T" in Ch 9, Sec 19, Tab 1 column "Vapour detection".

4.1.52 Turret compartments are those spaces and trunks that contain equipment and machinery for retrieval and release of the disconnectable turret mooring system, high-pressure hydraulic operating systems, fire protection arrangements and cargo transfer valves.

4.1.53 Vapour pressure is the equilibrium pressure of the saturated vapour above the liquid, expressed in Pascals (Pa) absolute at a specified temperature.

4.1.54 Void space is an enclosed space in the cargo area external to a cargo containment system, other than a hold space, ballast space, oil fuel tank, cargo pumps or compressor room, or any space in normal use by personnel.

5 Documentation to be submitted

5.1

5.1.1 Tab 2 lists the plans, information, analysis, etc. which are to be submitted in addition to the information required in the other Parts of the Rules for the parts of the ship not affected by the cargo, as applicable.

Table 2 : Documents to be submitted

No.	A/I	Documents
1	I	List of products to be carried, including maximum vapour pressure, maximum liquid temperature and other important design conditions
2	I	General arrangement plan, showing location of cargo tanks and fuel oil, ballast and other tanks
3	A	Gas-dangerous zones plan
4	A	Location of void spaces and accesses to dangerous zones
5	A	Air locks between safe and dangerous zones
6	A	Ventilation duct arrangement in gas-dangerous spaces and adjacent zones
7	A	Details of hull structure in way of cargo tanks, including support arrangement for tanks, saddles, anti-floating and anti-lifting devices, deck sealing arrangements, etc.
8	A	Calculation of the hull temperature in all the design cargo conditions
9	A	Distribution of quality and steel grades in relation to the contemplated actual temperature obtained by the calculation in item 8
10	A	Hull stress analysis
11	A	Hull ship motion analysis, where a direct analysis is preferred to the methods indicated in Ch 9, Sec 4
12	A	Intact and damage stability calculations
13	A	Scantlings, material and arrangement of the cargo containment system, including the secondary barrier, if any.
<p>Note 1: A : to be submitted for approval I : to be submitted for information.</p>		

No.	A/I	Documents
14	A	Stress analysis of the cargo tanks, including fatigue analysis and crack propagation analysis for type "B" tanks. This analysis may be integrated with that indicated in item 10
15	I	Calculation of the thermal insulation suitability, including boil-off rate and refrigeration plant capability, if any, cooling down and temperature gradients during loading and unloading operations
16	A	Details of insulation
17	A	Details of ladders, fittings and towers in tanks and relative stress analysis, if any
18	A	Details of tank domes and deck sealings
19	A	Plans, arrangement and calculations of safety relief valves
20	A	Details of cargo handling and vapour system, including arrangements and details of piping and fitting
21	A	Details of cargo pumps and cargo compressors
22	A	Details of process pressure vessels and relative valving arrangement
23	A	Piping stress analysis when $T < -110^{\circ}\text{C}$
24	A	Control cargo tank pressure philosophy (description)
25	A	Bilge and ballast system in cargo area
26	A	Gas freeing system in cargo tanks including inert gas system
27	A	Interbarrier space drainage, inerting and pressurisation systems
28	A	Ventilation system in cargo area
29	A	Hull structure heating system, if any
30	A	Refrigeration and reliquefaction plant system diagram, if any
31	A	Details of electrical equipment installed in cargo area, including the list of certified safe equipment and apparatus and electrical bonding of cargo tanks and piping
32	A	Schematic electrical wiring diagram in cargo area
33	A	Gas detection system
34	A	Cargo tank instrumentation, including cargo and hull temperature monitoring system
35	A	Emergency shutdown system
36	A	Jettison system, if any
37	A	Details of fire-extinguishing appliances and systems in cargo area
38	A	Loading and unloading operation description, including cargo tank filling limits
39	A	Cargo operating manual
40	A	Cargo tank testing and inspection procedures for in-service inspection as defined in Ch 9, Sec 4, [2.1.6]
41	A	Programme of gas trials
42	I	When applicable, P & A manual
43	I I A A A I I A A A	For machinery using gas as fuel: a) General arrangement plan of the machinery plant b) Description of the entire plant c) Gas piping plans for the machinery plant d) Complete list of the safety, gas detection and warning equipment e) Drawings of the boilers f) Detailed drawings of the gas inlet and fuel inlet equipment g) Gas characteristics h) General arrangement plan of the gas treatment plant, including gas compressors, prime movers and gas preheaters i) Drawings of the gas storage tanks j) Drawings of the gas compressors and preheaters
<p>Note 1: A : to be submitted for approval I : to be submitted for information.</p>		

6 Cargo equipment trials

6.1 Scope

6.1.1 Trials in working conditions

All the equipment to which this Chapter is applicable is to be tested in actual working conditions.

6.1.2 Trials to be carried out when the ship is loaded

Those trials which may only be carried out when the ship is loaded are to be held at the first loading of the ship.

For LNG carriers, the extent of the examinations that are to be conducted before and after the first loaded voyage is given in [6.2.4].

6.2 Extent of the tests

6.2.1 Cargo equipment testing procedure

The cargo equipment testing procedure is to be submitted to the Society for review.

6.2.2 Ships with mechanical refrigeration units

Ships fitted with a mechanical refrigeration unit are to be subjected to an initial testing procedure in order to check the suitability of the plant in respect of the applicable requirements. The recording of the data of the reliquefaction system, such as working duration and ambient conditions, may be carried out during the first loaded voyage.

6.2.3 Use of cargo as fuel

The arrangements for using cargo as fuel are to be subjected to a special testing procedure.

6.2.4 First loaded voyage of ships carrying liquefied natural gases (LNG) in bulk

a) The following examinations are to be conducted at the first full loading of the ship:

- 1) Priority to be given to latter stages of loading (approximately last 6 hours).
- 2) Review cargo logs and alarm reports.
- 3) Witness satisfactory operation of the following:
 - gas detection system
 - cargo control and monitoring systems such as level gauging equipment, temperature sensors, pressure gauges, cargo pumps and compressors, proper control of cargo heat exchangers, if operating, etc.
 - nitrogen generating plant or inert gas generator, if operating
 - nitrogen pressure control system for insulation, interbarrier, and annular spaces, as applicable
 - cofferdam heating system, if in operation
 - reliquefaction plant, if fitted
 - equipment fitted for the burning of cargo vapours such as boilers, engines, gas combustion units, etc., if operating.
- 4) Examination of on-deck cargo piping systems including expansion and supporting arrangements.
- 5) Witness topping off process for cargo tanks including high level alarms activated during normal loading.
- 6) Advise Master to carry out cold spot examination of the hull and external insulation during transit voyage to unloading port.

b) The following examinations are to be conducted at the first unloading of the ship:

- 1) Priority to be giving to the commencement of unloading (approximately first 4-6 hours).
- 2) Witness emergency shutdown system testing prior to commencement of unloading.
- 3) Review cargo logs and alarm reports.

- 4) Witness satisfactory operation of the following:
 - gas detection system
 - cargo control and monitoring systems such as level gauging equipment, temperature sensors, pressure gauges, cargo pumps and compressors, proper control of cargo heat exchangers, if operating, etc.
 - nitrogen generating plant or inert gas generator, if operating
 - nitrogen pressure control system for insulation, interbarrier, and annular spaces, as applicable
 - on membrane vessels, verify that the readings of the cofferdam and inner hull temperature sensors are not below the allowable temperature for the selected grade of steel. Review previous readings
 - cofferdam heating system, if in operation
 - reliquefaction plant and review of records from previous voyage
 - equipment fitted for the burning of cargo vapours such as boilers, engines, gas combustion units, etc., if operating.
- 5) Examination of on-deck cargo piping systems including expansion and supporting arrangements.
- 6) Obtain written statement from the Master that the cold spot examination was carried out during the transit voyage and found satisfactory. Where possible, the Surveyor should examine selected spaces.

7 Additional service features BOG-reliquefaction and LNG-subcooling

7.1 General

7.1.1 Application

The service notation **Liquefied gas carrier** is to be completed by the following additional service features indicating which systems are installed on board the ship to control the cargo tank pressure without losing cargo volume during navigation:

- a) The additional service feature **BOG-reliquefaction** is assigned, in accordance with Pt A, Ch 1, Sec 2, [4.4.5], to liquefied gas carriers equipped with a reliquefaction installation complying with the requirements of Ch 9, Sec 7, [3]
- b) The additional service feature **LNG-subcooling** is assigned, in accordance with Pt A, Ch 1, Sec 2, [4.4.5], to liquefied gas carriers equipped with a cooling installation aiming at reducing the cargo temperature and complying with the requirements of Ch 9, Sec 7, [6].

8 Additional service feature STL-SPM

8.1 General

8.1.1 Application

- a) The additional service feature **STL-SPM** is assigned, in accordance with Pt A, Ch 1, Sec 2, [4.4.5], to liquefied gas carriers used as regasification terminal, fitted forward with equipment for not permanent mooring, or for connection to single buoy, and complying with the requirements of the present Article.
- b) The buoy and the mooring system may be not included within classification. In case the buoy and the mooring are covered by class, the Rules for the Classification of Offshore Loading and Off loading Buoys (NR494) are applicable to the buoy and the **POSA** additional class notation may be assigned to the mooring system.

8.1.2 Scope

The following items are covered by the additional service feature **STL-SPM**:

- ship structure, in way of the mooring or the single buoy
- hatch cover
- cylinders
- swivel
- piping and risers
- stoppers
- winch
- interface between equipment and ship structure
- ventilation
- handling equipment (HPU and control system)
- drainage of compartment
- fire and gas detection system
- fire extinction system
- emergency escape.

8.1.3 Applicable rules

- a) The items listed in [8.1.2] are to comply with the applicable requirements of IGC code.
- b) Components of the equipment used for mooring at single point are to comply with the applicable requirements of Pt B, Ch 12, Sec 4 for **ETA** (Emergency Towing Arrangement) and Pt F, Ch 11, Sec 3, for **SPM** (Single Point Mooring).
- c) The swivel is to be classed according to Section 8 of the NR494 Rules for the Classification of Offshore Loading and Off loading Buoys.
- d) The lifting appliances are to meet the applicable requirements of NR526 Rules for Lifting Appliances.
- e) The risers are to be specially considered.

8.2 Documentation to be submitted

8.2.1 Plans and documents to be submitted for approval

In addition to the documents listed in Pt B, Ch 1, Sec 4, the following plans and documents are to be submitted to the Society for approval:

- ship structure drawings, in way of the mooring or the single buoy
- local reinforcements of ship structure below equipment
- ventilation plan
- emergency escape
- drawings of equipment
- fire and gas detection, wiring and arrangement diagram
- cable list
- STL, auxiliary and bridge system
- lighting installation, wiring and arrangement diagram
- electrical starter circuit diagram
- architecture diagram of control and safety system
- control and wiring diagram of:
 - hydraulic system for buoy locking devices
 - winches
- fire extinction
- drainage system.

8.2.2 Plans and documents to be submitted for information

The following documents are to be submitted to the Society for information:

- DLOC (design load operating conditions)
- structural calculation
- fatigue calculation
- model test results
- explosion calculation
- CCTV diagram
- operation procedure of system.

8.3 Structural design

8.3.1 Design loads

- a) Model tests in mooring conditions are generally to be carried out to determine the loads.
- b) For the ship structure, calculations based on test results or mooring and hydrodynamic calculations are to be submitted and subject to special examination by the Society.

8.3.2 Scantlings

The deck structure supporting accessories is to be reinforced on basis of loads given by the designer.

8.4 Mechanical installation

8.4.1 When hydraulic installation is used, it is to be in compliance with the applicable requirements of Pt C, Ch 1, Sec 10, [14].

8.4.2 The hydraulic cylinders are considered as pressure vessels; the scantlings of the shells and the ends are to be in compliance with the applicable requirements of Pt C, Ch 1, Sec 3.

8.4.3 Securing devices are to be simple to operate and easily accessible.

8.4.4 Securing devices are to be equipped with mechanical locking arrangement (self locking or separate arrangement), or to be of the gravity type. Where hydraulic securing devices are applied, they have to remain locked in the event of loss of the hydraulic fluid.

8.4.5 The opening and closing systems as well as securing and locking devices are to be interlocked in such a way that they can only operate in the proper sequence.

8.4.6 The hydraulic system for securing and locking devices is to be isolated from other hydraulic circuits, when in closed position.

8.5 Electrical and automation installation

8.5.1 Unless otherwise specified, the requirements in Part C, Chapter 2 and Part C, Chapter 3 are applicable to the system fitted in STL.

8.5.2 The STL room is to be considered as hazardous area. Electrical equipment are to be avoided in this area. When electrical equipment are fitted, they are to be of a safe type IIA T3 and considered as Zone 1.

8.5.3 The STL system is to be considered as a primary essential service.

8.5.4 The electrical equipment located in flooded space are to be IP 68 for the appropriate depth.

8.5.5 The electrical equipment located in non flooded space are to be IP 67.

8.5.6 Local control of systems is always to be available.

Section 2 Ship Survival Capability and Location of Cargo Tanks

1 General

1.1

1.1.1 Ships subject to the Code shall survive the hydrostatic effects of flooding following assumed hull damage caused by some external force. In addition, to safeguard the ship and the environment, the cargo tanks shall be protected from penetration in the case of minor damage to the ship resulting, for example, from contact with a jetty or tug, and also given a measure of protection from damage in the case of collision or grounding, by locating them at specified minimum distances inboard from the ship's shell plating. Both the damage to be assumed and the proximity of the tanks to the ship's shell shall be dependent upon the degree of hazard presented by the product to be carried. In addition, the proximity of the cargo tanks to the ship's shell shall be dependent upon the volume of the cargo tank.

1.1.2 Ships subject to the Code shall be designed to one of the following standards:

- a) A type 1G ship is a gas carrier intended to transport the products indicated in Ch 9, Sec 19 that require maximum preventive measures to preclude their escape
- b) A type 2G ship is a gas carrier intended to transport the products indicated in Ch 9, Sec 19, that require significant preventive measures to preclude their escape
- c) A type 2PG ship is a gas carrier of 150 m in length or less intended to transport the products indicated in Ch 9, Sec 19 that require significant preventive measures to preclude their escape, and where the products are carried in type C independent tanks designed (see Ch 9, Sec 4, [10]) for a MARVS of at least 0,7 MPa gauge and a cargo containment system design temperature of -55°C or above. A ship of this description that is over 150 m in length is to be considered a type 2G ship
- d) A type 3G ship is a gas carrier intended to carry the products indicated in Ch 9, Sec 19 that require moderate preventive measures to preclude their escape.

Therefore, a type 1G ship is a gas carrier intended for the transportation of products considered to present the greatest overall hazard and types 2G/2PG and type 3G for products of progressively lesser hazards. Accordingly, a type 1G ship shall survive the most severe standard of damage and its cargo tanks shall be located at the maximum prescribed distance inboard from the shell plating.

1.1.3 The ship type required for individual products is indicated in Ch 9, Sec 19, Tab 1.

1.1.4 If a ship is intended to carry more than one of the products listed in Ch 9, Sec 19, the standard of damage shall correspond to the product having the most stringent ship type requirements. The requirements for the location of individual cargo tanks, however, are those for ship types related to the respective products intended to be carried.

1.1.5 For the purpose of this Code, the position of the moulded line for different containment systems is shown in Fig 5 to Fig 9.

2 Freeboard and stability

2.1 General

2.1.1 Ships subject to the Code may be assigned the minimum freeboard permitted by the International Convention on Load Lines in force. However, the draught associated with the assignment shall not be greater than the maximum draught otherwise permitted by this Code.

2.1.2 The stability of the ship, in all seagoing conditions and during loading and unloading cargo, shall comply with the requirements of the International Code on Intact Stability. This includes partial filling and loading and unloading at sea, when applicable. Stability during ballast water operations shall fulfil stability criteria.

Note 1: Refer to the International Code on Intact Stability, 2008 (2008 IS Code), adopted by the Maritime Safety Committee of the Organization by resolution MSC.267(85).

2.1.3 The stability of the ship for the loading conditions in Pt B, Ch 3, App 2, [1.2.8] is to be in compliance with the requirements in Pt B, Ch 3, Sec 2.

2.1.4 When calculating the effect of free surfaces of consumable liquids for loading conditions, it shall be assumed that, for each type of liquid, at least one transverse pair or a single centre tank has a free surface. The tank or combination of tanks to be taken into account shall be those where the effect of free surfaces is the greatest. The free surface effect in undamaged compartments shall be calculated by a method according to the International Code on Intact Stability.

2.1.5 The free surface effect is to be calculated in accordance with Pt B, Ch 3, Sec 2, [4].

2.1.6 *Solid ballast shall not normally be used in double bottom spaces in the cargo area. Where, however, because of stability considerations, the fitting of solid ballast in such spaces becomes unavoidable, its disposition shall be governed by the need to enable access for inspection and to ensure that the impact loads resulting from bottom damage are not directly transmitted to the cargo tank structure.*

2.1.7 *The Master of the ship shall be supplied with a loading and stability information booklet. This booklet shall contain details of typical service conditions, loading, unloading and ballasting operations, provisions for evaluating other conditions of loading and a summary of the ship's survival capabilities. The booklet shall also contain sufficient information to enable the Master to load and operate the ship in a safe and seaworthy manner.*

2.1.8 The Master of the ship is to be supplied with a Loading Manual as specified in Pt B, Ch 1, Sec 5, [2] and a Trim and Stability booklet as specified in Pt B, Ch 3, App 2.

2.1.9 *All ships, subject to the Code shall be fitted with a stability instrument, capable of verifying compliance with intact and damage stability requirements, approved by the Society having regard to the performance standards recommended by the Organization.*

Note 1: Refer to part B, chapter 4, of the International Code on Intact Stability, 2008 (2008 IS Code), as amended; the Guidelines for the Approval of Stability Instruments (MSC.1/Circ.1229), annex, section 4, as amended; and the technical standards defined in part 1 of the Guidelines for verification of damage stability requirements for tankers (MSC.1/Circ.1461).

- a) *ships constructed before 1 July 2016 shall comply with the requirements of [2.1.9] at the first scheduled renewal survey of the ship after 1 July 2016 but not later than 1 July 2021*
- b) *notwithstanding the requirements of item a), a stability instrument installed on a ship constructed before 1 July 2016 need not be replaced provided it is capable of verifying compliance with intact and damage stability, to the satisfaction of the Society, and*
- c) *for the purposes of control under SOLAS regulation XI-1/4, the Society shall issue a document of approval for the stability instrument.*

2.1.10 *The Society may waive the requirements of [2.1.9] for the following ships, provided the procedures employed for intact and damage stability verification maintain the same degree of safety, as being loaded in accordance with the approved conditions.*

Note 1: Refer to operational guidance provided in part 2 of the Guidelines for verification of damage stability requirements for tankers (MSC.1/Circ.1461).

Any such waiver shall be duly noted on the International Certificate of Fitness:

- a) *ships which are on a dedicated service, with a limited number of permutations of loading such that all anticipated conditions have been approved in the stability information provided to the Master in accordance with the requirements of [2.1.7]*
- b) *ships where stability verification is made remotely by a means approved by the Society*
- c) *ships which are loaded within an approved range of loading conditions, or*
- d) *ships constructed before 1 July 2016 provided with approved limiting KG/GM curves covering all applicable intact and damage stability requirements.*

2.1.11 Conditions of loading

Damage survival capability shall be investigated on the basis of loading information submitted to the Society for all anticipated conditions of loading and variations in draught and trim. This shall include ballast and, where applicable, cargo heel.

Loading conditions other than those in the Loading Manual and the Trim and Stability booklet are to be previously submitted to the Society. Alternatively, such cases may be examined by the Master or a delegated officer when a loading instrument approved in accordance with the requirements in Pt B, Ch 1, Sec 5, [3] is installed on board.

3 Damage assumptions

3.1 General

3.1.1 *The assumed maximum extent of damage shall be as per Tab 1.*

3.2 Other damage

3.2.1 *If any damage of a lesser extent than the maximum damage specified in [3.1.1] would result in a more severe condition, such damage shall be assumed*

3.2.2 *Local damage anywhere in the cargo area extending inboard distance "d" as defined in [4.1.1], measured normal to the moulded line of the outer shell shall be considered. Bulkheads shall be assumed damaged when the relevant list items of [6.1.2] apply. If a damage of a lesser extent than "d" would result in a more severe condition, such damage shall be assumed.*

Table 1 : Assumed maximum extent of damage

Side damage	Longitudinal extent:	1/3 L ^{2/3} or 14,5 m, whichever is less
	Transverse extent: measured inboard from the moulded line of the outer shell at right angles to the centreline at the level of the summer waterline	B/5 or 11,5 m, whichever is less
	Vertical extent: from the moulded line of the outer shell	Upwards, without limit

Bottom damage		For 0,3 L from the forward perpendicular of the ship	Any other part of the ship
	Longitudinal extent:	1/3L ^{2/3} or 14,5 m, whichever is less	1/3L ^{2/3} or 14,5 m, whichever is less
	Transverse extent:	B/6 or 10 m, whichever is less	B/6 or 5 m, whichever is less
	Vertical extent:	B/15 or 2 m, whichever is less measured from the moulded line of the bottom shell plating at centreline (see [4.1.4])	B/15 or 2 m, whichever is less measured from the moulded line of the bottom shell plating at centreline (see [4.1.4])

4 Location of cargo tanks

4.1 General

4.1.1 Cargo tanks shall be located at the following distances inboard:

a) Type 1G ships:

from the moulded line of the outer shell, not less than the transverse extent of side damage specified in Tab 1 and, from the moulded line of the bottom shell at centreline, not less than the vertical extent of bottom damage specified in Tab 1, and nowhere less than the distance *d*, in m, defined as follows:

- for V_c below or equal to 1000 m³:
 $d = 0,8$
- for $1000 \text{ m}^3 < V_c < 5000 \text{ m}^3$:
 $d = 0,75 + V_c \cdot 0,2/4000$
- for $5000 \text{ m}^3 \leq V_c < 30000 \text{ m}^3$:
 $d = 0,8 + V_c / 25000$
- for $V_c \geq 30000 \text{ m}^3$:
 $d = 2,0$

where

V_c : 100% of the gross design volume of the individual cargo tank at 20°C, including domes and appendages (see Fig 1 and Fig 2). For the purpose of cargo tank protective distances, the cargo tank volume is the aggregate volume of all the parts of tank that have a common bulkhead(s), and

d : Distance, in m, measured at any cross-section at a right angle from the moulded line of outer shell.

Tank size limitations may apply to type 1G ship cargoes in accordance with Ch 9, Sec 17.

b) Types 2G/2PG:

from the moulded line of the bottom shell at centreline not less than the vertical extent of bottom damage specified in Tab 1 and nowhere less than the distance *d* as indicated in [4.1.1], item a) (see Fig 1 and Fig 2).

c) Type 3G ships:

from the moulded line of the bottom shell at centreline not less than the vertical extent of bottom damage specified in Tab 1 and nowhere less than the distance *d*, where $d = 0,8 \text{ m}$ from the moulded line of outer shell (see Fig 1 and Fig 4).

4.1.2 Deck cargo tanks are to be located not less than 800 mm inboard from the side shell.

4.1.3 For the purpose of tank location, the vertical extent of bottom damage shall be measured to the inner bottom when membrane or semi-membrane tanks are used, otherwise to the bottom of the cargo tanks. The transverse extent of side damage shall be measured to the longitudinal bulkhead when membrane or semi-membrane tanks are used, otherwise to the side of the cargo tanks. The distances indicated in [3] and [4] shall be applied as in Fig 5 to Fig 9. These distances shall be measured plate to plate, from the moulded line to the moulded line, excluding insulation.

4.1.4 Except for type 1G ships, suction wells installed in cargo tanks may protrude into the vertical extent of bottom damage specified in Tab 1 provided that such wells are as small as practicable and the protrusion below the inner bottom plating does not exceed 25% of the depth of the double bottom or 350 mm, whichever is less. Where there is no double bottom, the protrusion below the upper limit of bottom damage shall not exceed 350 mm. Suction wells installed in accordance with this paragraph may be ignored when determining the compartments affected by damage.

4.1.5 Cargo tanks shall not be located forward of the collision bulkhead

Figure 1 : Cargo tank location requirements - Centreline profile - Type 1G, 2G, 2GP and 3G ships

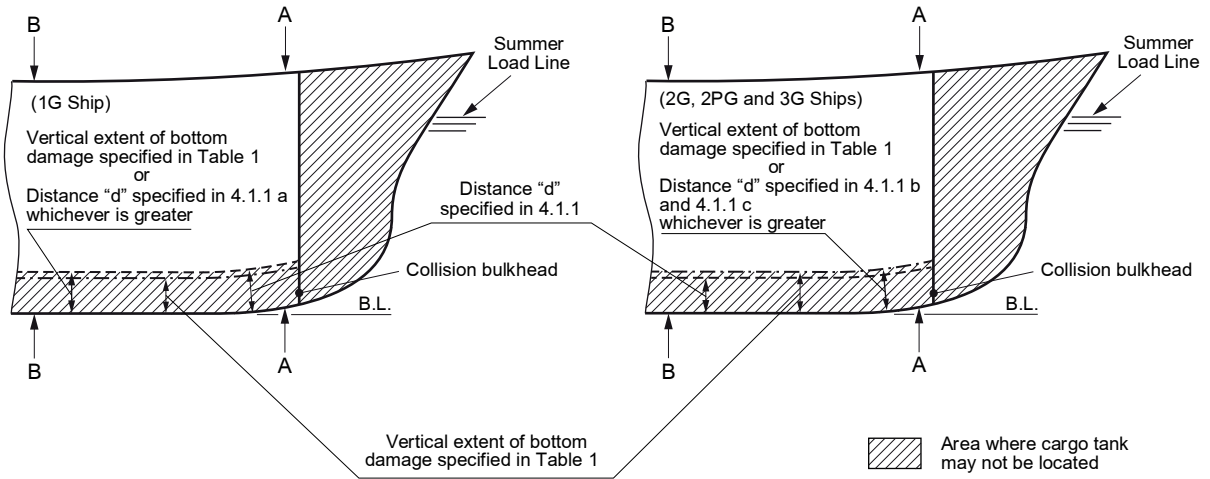

Figure 2 : Cargo tank location requirements - Transverse sections - Type 1G ships

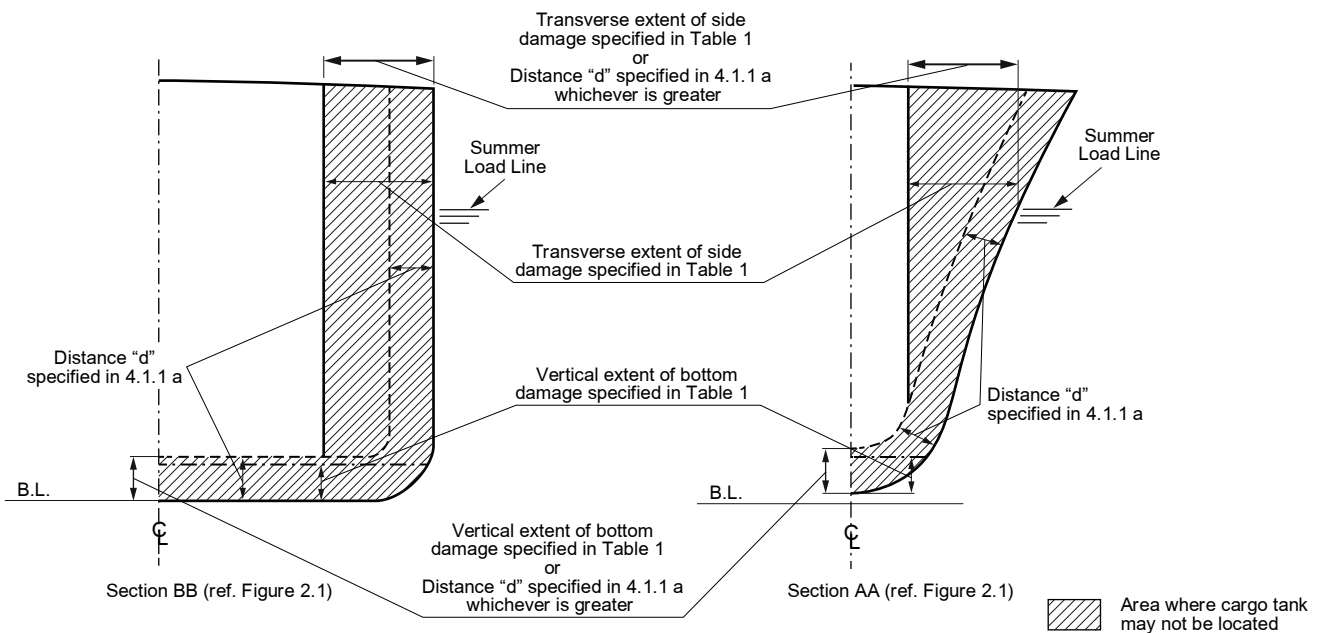

Figure 3 : Cargo tank location requirements - Transverse sections - Type 2G and 2PG ships

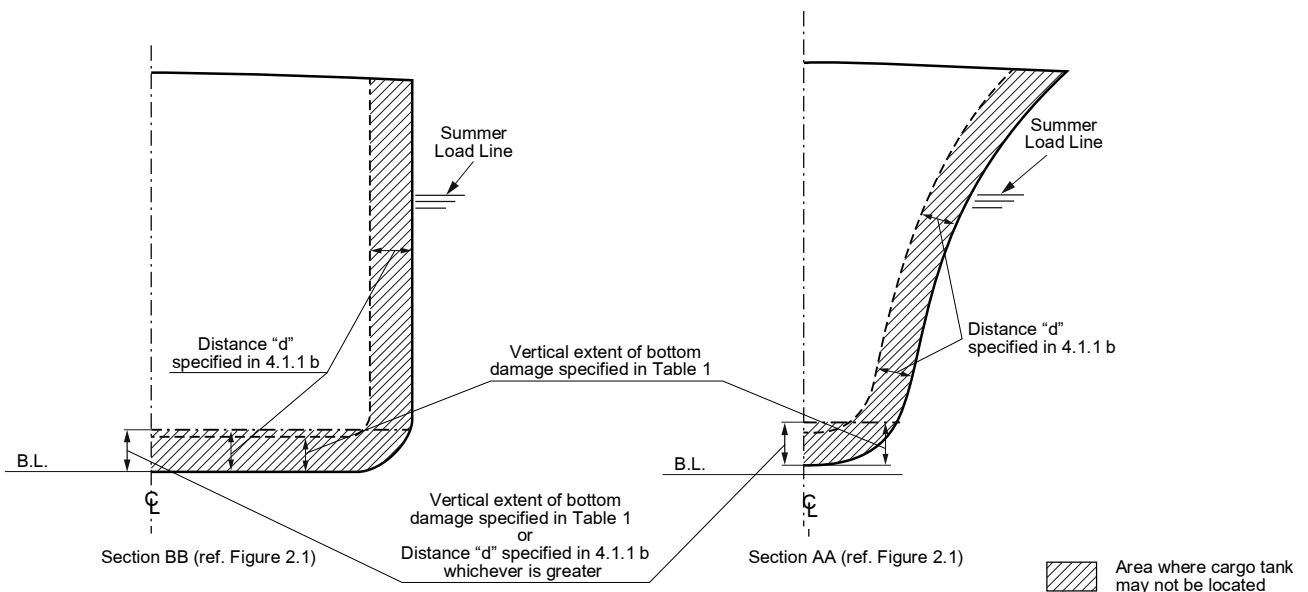

Figure 4 : Cargo tank location requirements - Transverse sections - Type 3G ships

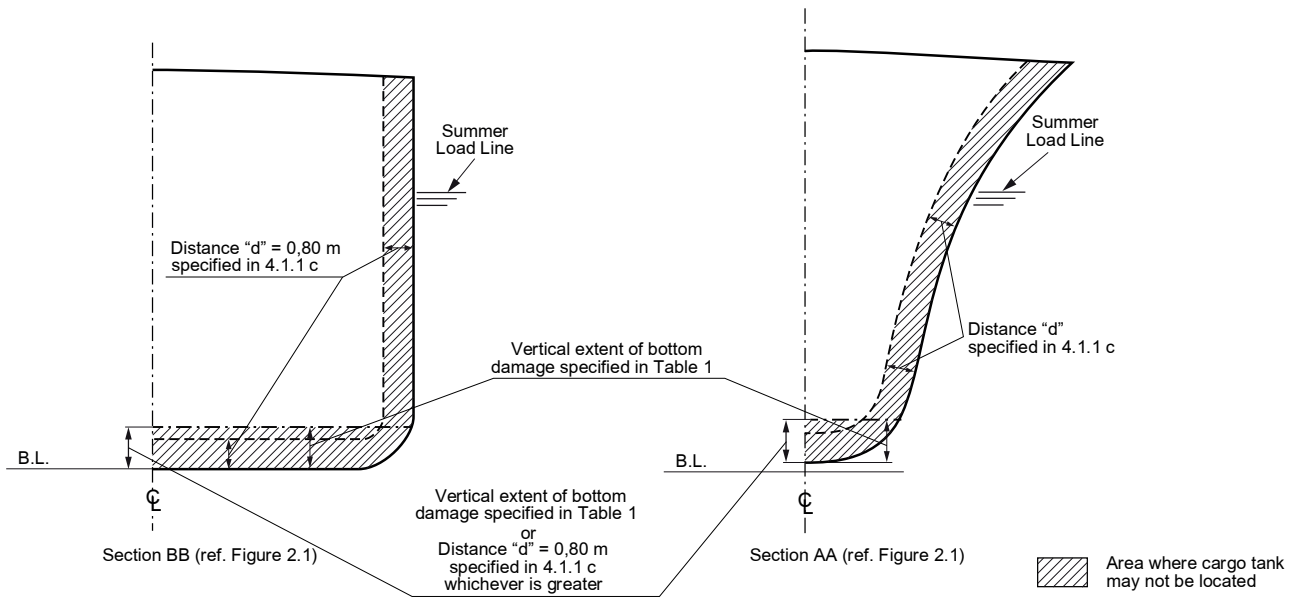

Figure 5 : Protective distance - Independent primary tank

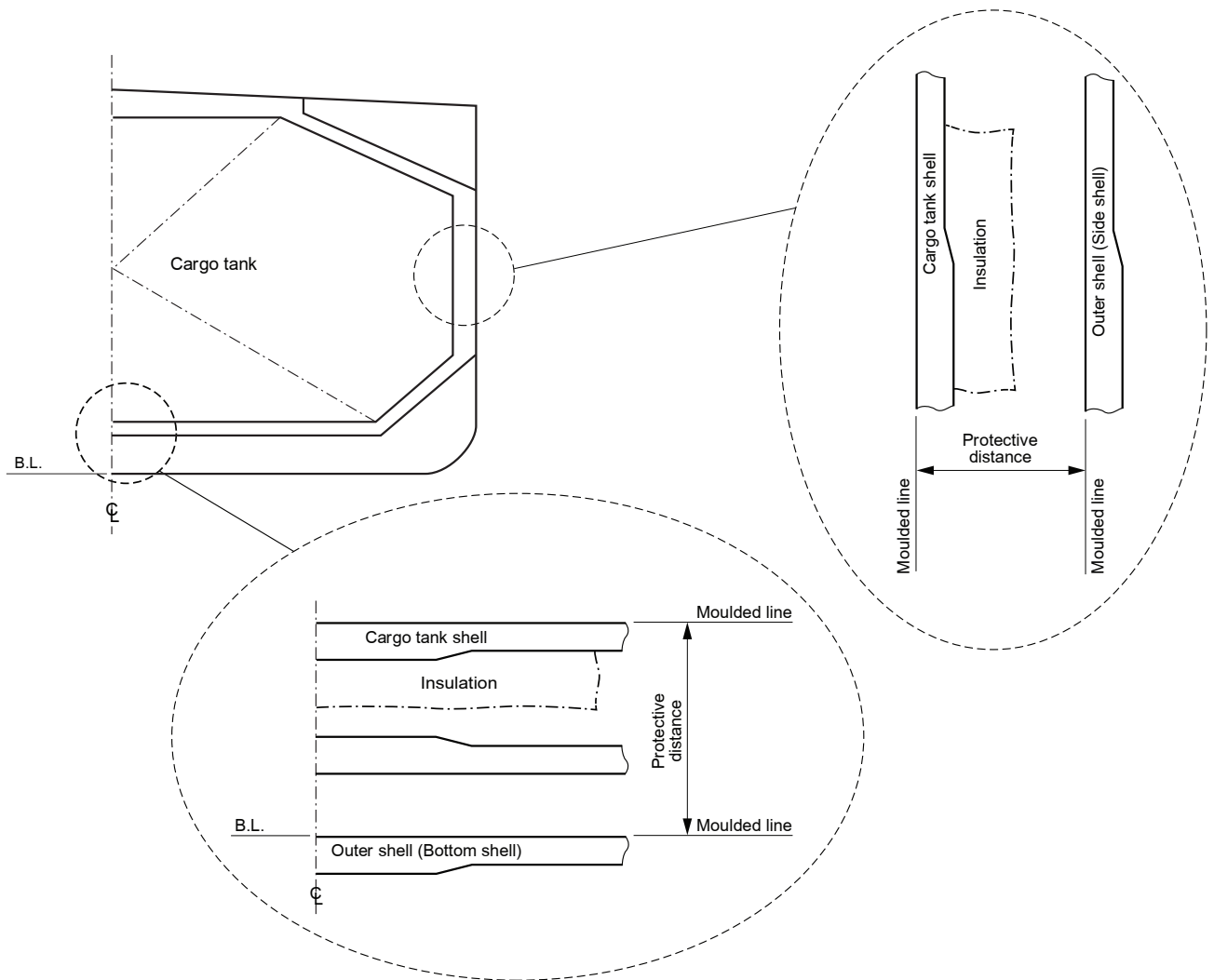

Figure 6 : Protective distance - Semi-membrane tank

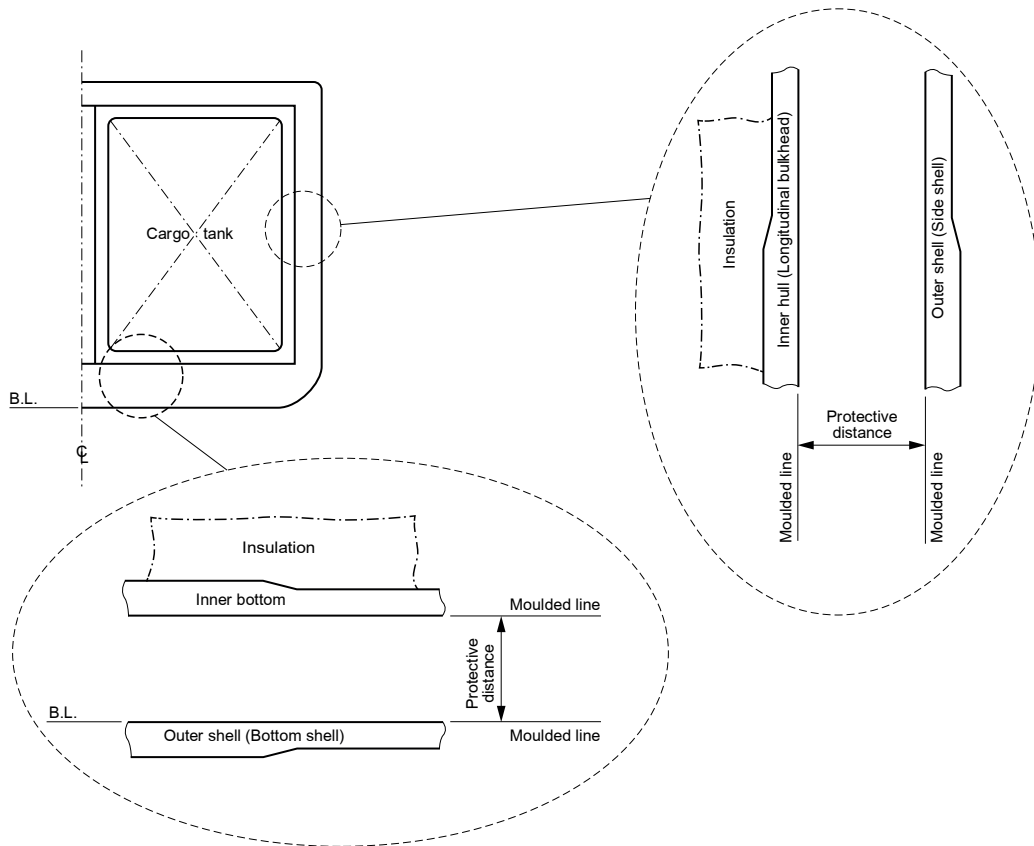

Figure 7 : Protective distance - Membrane tank

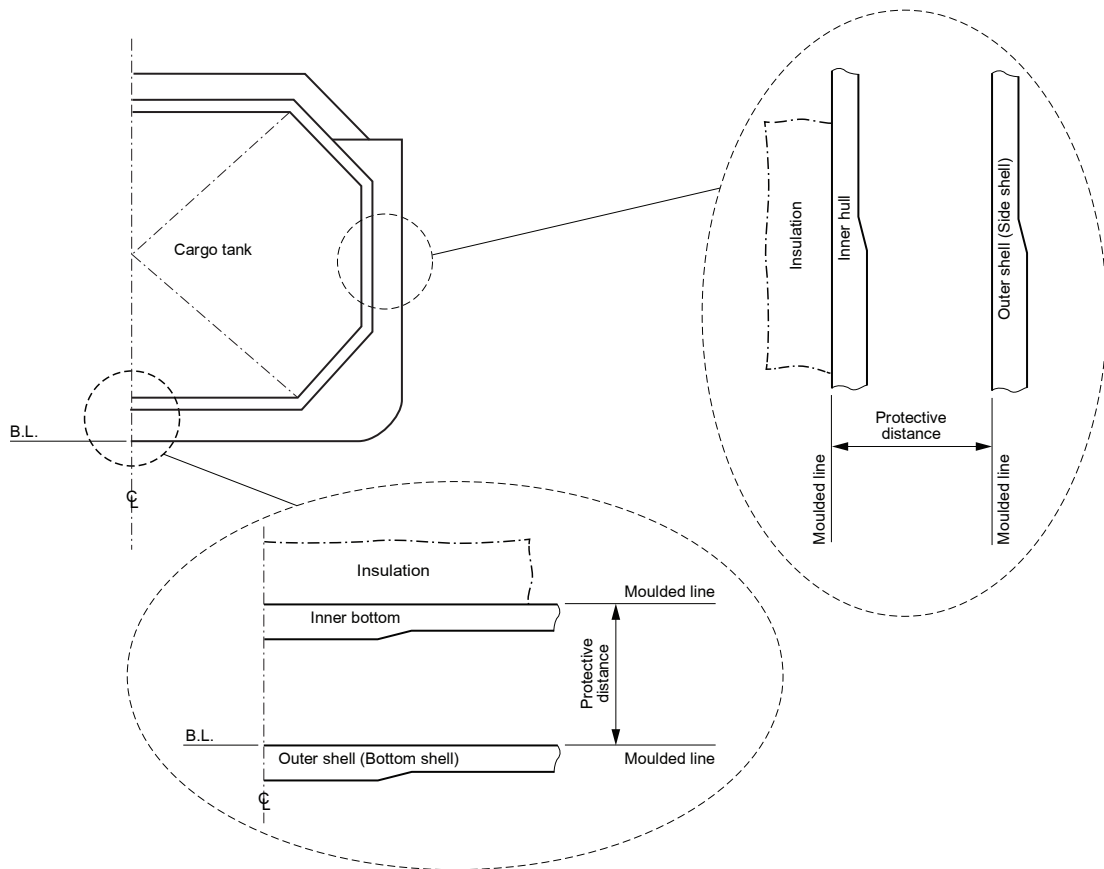

Figure 8 : Protective distance - Spherical tank

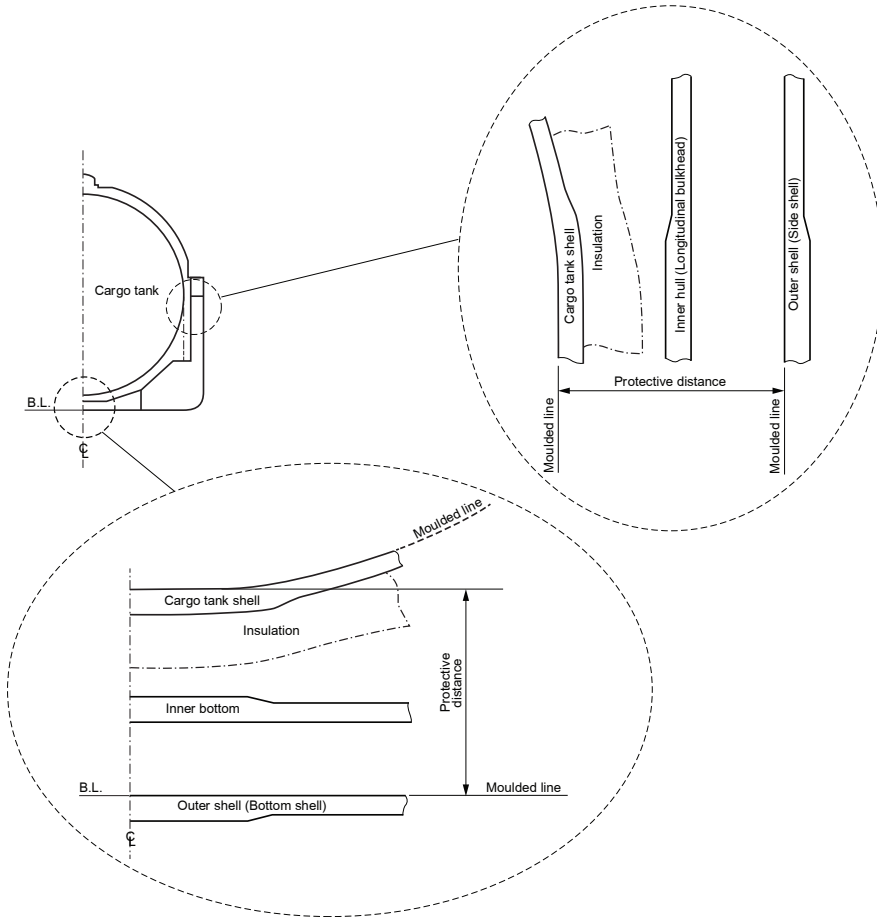
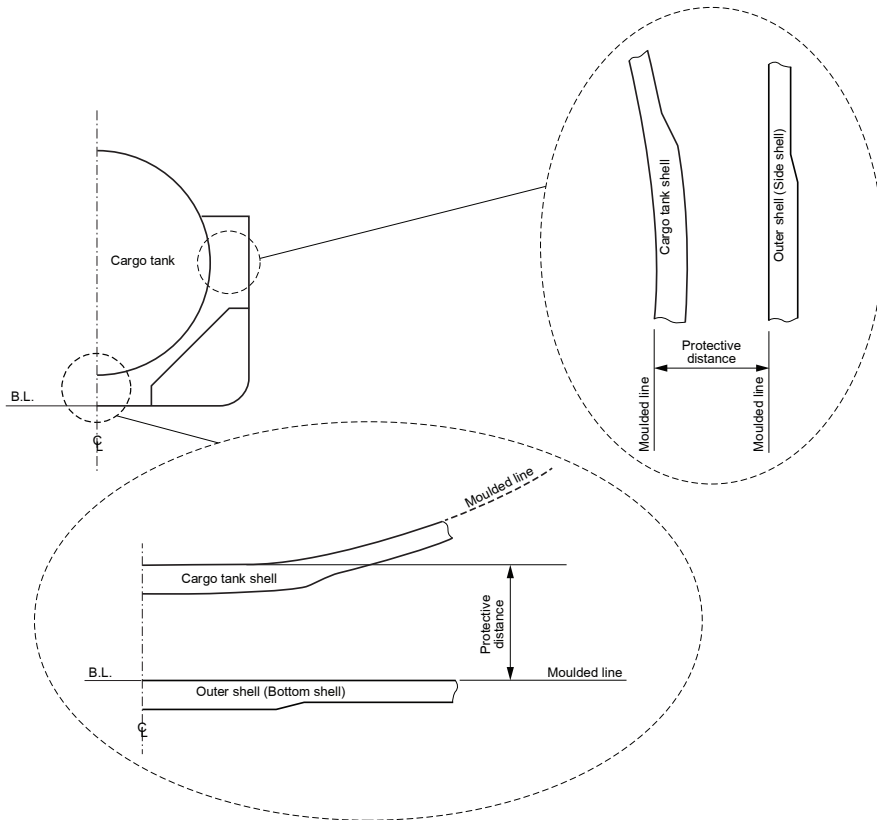

Figure 9 : Protective distance - Pressure type tank



5 Flood assumptions

5.1 General

5.1.1 The requirements of [7] shall be confirmed by calculations that take into consideration the design characteristics of the ship, the arrangements, configuration and contents of the damaged compartments, the distribution, relative densities and the free surface effects of liquids and the draught and trim for all conditions of loading.

5.1.2 The permeabilities of spaces assumed to be damaged shall be as per Tab 2.

5.1.3 Wherever damage penetrates a tank containing liquids, it shall be assumed that the contents are completely lost from that compartment and replaced by salt water up to the level of the final plane of equilibrium.

5.1.4 Where the damage between transverse watertight bulkheads is envisaged, as specified in [6.1.2], item d), item e) and item f), transverse bulkheads shall be spaced at least at a distance equal to the longitudinal extent of damage specified in Tab 1 (see Side damage / longitudinal extent) in order to be considered effective. Where transverse bulkheads are spaced at a lesser distance, one or more of these bulkheads within such extent of damage shall be assumed as non-existent for the purpose of determining flooded compartments. Further, any portion of a transverse bulkhead bounding side compartments or double bottom compartments shall be assumed damaged if the watertight bulkhead boundaries are within the extent of vertical or horizontal penetration required by [3]. Also, any transverse bulkhead shall be assumed damaged if it contains a step or recess of more than 3 m in length located within the extent of penetration of assumed damage. The step formed by the after peak bulkhead and the after peak tank top shall not be regarded as a step for the purpose of this paragraph.

Table 2 : Permeabilities of spaces assumed to be damaged

Spaces	Permeabilities
Stores	0,60
Accommodation	0,95
Machinery	0,85
Voids	0,95
Hold spaces	0,951
Consumable liquids	0 to 0,952
Other liquids	0 to 0,952
<p>Note 1: Other values of permeability can be considered based on the detailed calculations. Interpretations of regulation of part B-1 of SOLAS chapter II-1 (MSC/Circ.651) are referred.</p> <p>Note 2: The permeability of partially filled compartments shall be consistent with the amount of liquid carried in the compartment.</p>	

5.1.5 The ship shall be designed to keep unsymmetrical flooding to the minimum consistent with efficient arrangements.

5.1.6 Equalization arrangements requiring mechanical aids such as valves or cross-levelling pipes, if fitted, shall not be considered for the purpose of reducing an angle of heel or attaining the minimum range of residual stability to meet the requirements of [7.1.3], and sufficient residual stability shall be maintained during all stages where equalization is used. Spaces linked by ducts of large cross-sectional area may be considered to be common.

5.1.7 If pipes, ducts, trunks or tunnels are situated within the assumed extent of damage penetration, as defined in [3], arrangements shall be such that progressive flooding cannot thereby extend to compartments other than those assumed to be flooded for each case of damage.

5.1.8 Tunnels, ducts, pipes, doors, bulkheads and decks which might form watertight boundaries of intact spaces in the case of assumed conventional damage are to have minimum strength adequate to withstand the pressure height corresponding to the deepest equilibrium waterline in damaged conditions.

5.1.9 The buoyancy of any superstructure directly above the side damage shall be disregarded. However, the unflooded parts of superstructures beyond the extent of damage may be taken into consideration, provided that:

- they are separated from the damaged space by watertight divisions and the requirements of [7.1.3], item a) in respect of these intact spaces are complied with; and
- openings in such divisions are capable of being closed by remotely operated sliding watertight doors and unprotected openings are not immersed within the minimum range of residual stability required in [7.1.3], item a). However, the immersion of any other openings capable of being closed weathertight may be permitted.

6 Standard of damage

6.1 General

6.1.1 The longitudinal extent of damage to the superstructure (see also [5.1.9]) in the case of side damage to a machinery space aft, as per [6.1.2], is to be the same as the longitudinal extent of the side damage to the machinery space (see Fig 10).

Figure 10 : Longitudinal extension of superstructure damage

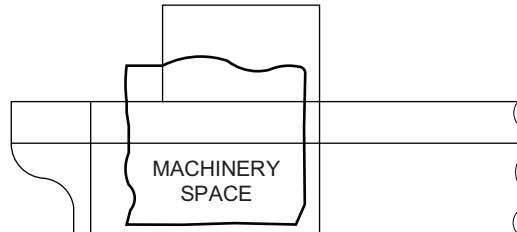

6.1.2 Ships shall be capable of surviving the damage indicated in [3] with the flood assumptions in [5], to the extent determined by the ship's type, according to the following standards:

- a type 1G ship shall be assumed to sustain damage anywhere in its length
- a type 2G ship of more than 150 m in length shall be assumed to sustain damage anywhere in its length
- a type 2G ship of 150 m in length or less shall be assumed to sustain damage anywhere in its length, except involving either of the bulkheads bounding a machinery space located aft
- a type 2PG ship shall be assumed to sustain damage anywhere in its length except involving transverse bulkheads spaced further apart than the longitudinal extent of side damage as specified in Tab 1
- a type 3G ship of 80 m in length or more shall be assumed to sustain damage anywhere in its length, except involving transverse bulkheads spaced further apart than the longitudinal extent of side damage specified in Tab 1, and
- a type 3G ship less than 80 m in length shall be assumed to sustain damage anywhere in its length, except involving transverse bulkheads spaced further apart than the longitudinal extent of side damage specified in Tab 1 and except damage involving the machinery space when located after.

The flooding of the machinery space, if located aft on a type 3G ship less than 80 m in length, is to comply as far as practicable with the criteria in [7]. Relaxation of parts of these requirements may be accepted on a case-by-case basis.

6.1.3 In the case of small type 2G/2PG and 3G ships that do not comply in all respects with the appropriate requirements of [6.1.2], item c), item e) and item f), special dispensations may only be considered by the Society provided that alternative measures can be taken which maintain the same degree of safety. The nature of the alternative measures shall be approved and clearly stated and be available to the port Administration. Any such dispensation shall be duly noted on the International Certificate of Fitness for the Carriage of Liquefied Gases in Bulk.

7 Survival requirements

7.1 General

7.1.1 Ships subject to the Code shall be capable of surviving the assumed damage specified in [3], to the standard provided in [6], in a condition of stable equilibrium and shall satisfy the following criteria.

7.1.2 Ships are to be capable of surviving the assumed damage specified in [3.1.1] and [3.2] to the standard provided in [6.1.2] and for the loading conditions in Pt B, Ch 3, App 2, [1.2.8] in a condition of stable equilibrium and such as to satisfy the criteria in [7].

7.1.3 In any stage of flooding:

- the waterline, taking into account sinkage, heel and trim, shall be below the lower edge of any opening through which progressive flooding or downflooding may take place. Such openings shall include air pipes and openings that are closed by means of weathertight doors or hatch covers and may exclude those openings closed by means of watertight manhole covers and watertight flush scuttles, small watertight cargo tank hatch covers that maintain the high integrity of the deck, remotely operated watertight sliding doors, hinged watertight access doors with open/closed indication locally and at the navigation bridge, of the quick-acting or single-action type that are normally closed at sea, hinged watertight doors that are permanently closed at sea and sidescuttles of the non-opening type;
- the maximum angle of heel due to unsymmetrical flooding shall not exceed 30°, and

c) the residual stability during intermediate stages of flooding shall not be less than that required by item a).

The criteria applied to the residual stability during intermediate stages of flooding are to be those relevant to the final stage of flooding as specified in [7.1.4]. However, small deviations from these criteria may be accepted by the Society on a case-by-case basis.

7.1.4 At final equilibrium after flooding:

a) the righting lever curve shall have a minimum range of 20° beyond the position of equilibrium in association with a maximum residual righting lever of at least 0,1 m within the 20° range; the area under the curve within this range shall not be less than 0,0175 m-radians. The 20° range may be measured from any angle commencing between the position of equilibrium and the angle of 25° (or 30° if no deck immersion occurs). Unprotected openings shall not be immersed within this range unless the space concerned is assumed to be flooded. Within this range, the immersion of any of the openings listed in [7.1.3] and other openings capable of being closed weathertight may be permitted.

Note 1: "other openings capable of being closed weathertight" do not include ventilators that have to remain open to supply air to the engine room or emergency generator room for the effective operation of the ship.

See also Fig 11.

b) the emergency source of power shall be capable of operating.

Figure 11 : Range of positive stability

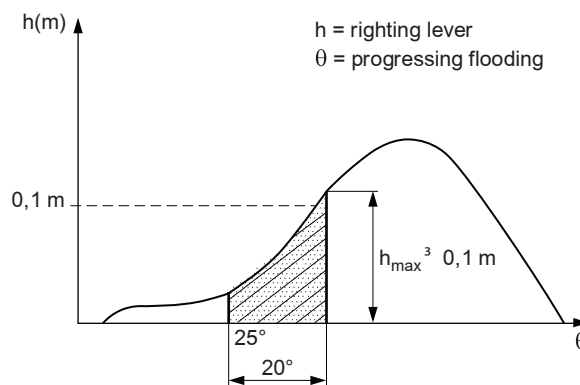

Section 3 Ship Arrangements

1 General

1.1 Segregation of the cargo area

1.1.1 Hold spaces shall be segregated from machinery and boiler spaces, accommodation spaces, service spaces, control stations, chain lockers, domestic water tanks and from stores. Hold spaces shall be located forward of machinery spaces of category A. Alternative arrangements, including locating machinery spaces of category A forward, may be accepted, based on SOLAS regulation II-2/17, after further consideration of involved risks, including that of cargo release and the means of mitigation.

1.1.2 Bow thrusters are allowed to be fitted forward of the hold spaces.

1.1.3 Where cargo is carried in a cargo containment system not requiring a complete or partial secondary barrier, segregation of hold spaces from spaces referred to in [1.1.1] or spaces either below or outboard of the hold spaces may be effected by cofferdams, oil fuel tanks or a single gastight bulkhead of all-welded construction forming an "A-60" class division. A gastight "A-0" class division is acceptable if there is no source of ignition or fire hazard in the adjoining spaces.

1.1.4 Where cargo is carried in a cargo containment system requiring a complete or partial secondary barrier, segregation of hold spaces from spaces referred to in [1.1.1], or spaces either below or outboard of the hold spaces that contain a source of ignition or fire hazard, shall be effected by cofferdams or oil fuel tanks. A gastight "A-0" class division is acceptable if there is no source of ignition or fire hazard in the adjoining spaces.

1.1.5 Hold spaces may be separated from each other by single bulkheads. Where cofferdams are used instead of single bulkheads, they may be used as ballast tanks subject to special approval by the Society.

1.1.6 Turret compartments segregation from spaces referred to in [1.1.1], or spaces either below or outboard of the turret compartment that contain a source of ignition or fire hazard, shall be effected by cofferdams or an A-60 class division. A gastight "A-0" class division is acceptable if there is no source of ignition or fire hazard in the adjoining spaces.

1.1.7 In addition, the risk of fire propagation from turret compartments to adjacent spaces shall be evaluated by a risk analysis (see Ch 9, Sec 1, [2.1.11]) and further preventive measures, such as the arrangement of a cofferdam around the turret compartment, shall be provided if needed.

1.1.8 When cargo is carried in a cargo containment system requiring a complete or partial secondary barrier:

- at temperatures below -10°C , hold spaces shall be segregated from the sea by a double bottom, and
- at temperatures below -55°C , the ship shall also have a longitudinal bulkhead forming side tanks.

1.1.9 Arrangements shall be made for sealing the weather decks in way of openings for cargo containment systems.

1.2 Accommodation, service and machinery spaces and control stations

1.2.1 No accommodation space, service space or control station shall be located within the cargo area. The bulkhead of accommodation spaces, service spaces or control stations that face the cargo area shall be so located as to avoid the entry of gas from the hold space to such spaces through a single failure of a deck or bulkhead on a ship having a containment system requiring a secondary barrier.

1.2.2 Some acceptable and unacceptable arrangements of accommodation spaces, with respect to cargo tanks, are shown in Fig 1.

Figure 1 : Acceptability of common corners between hold spaces and other spaces

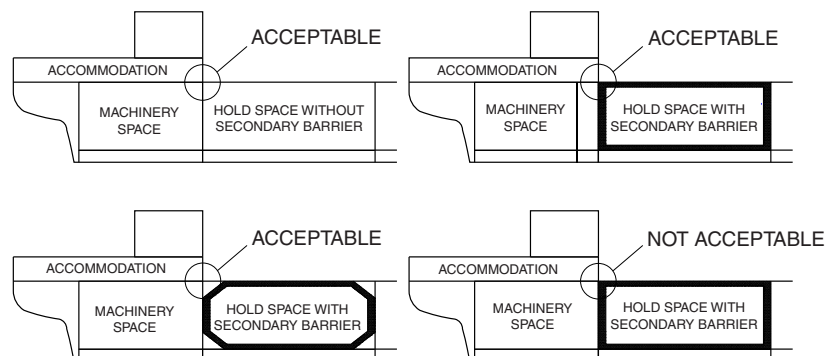

1.2.3 *To guard against the danger of hazardous vapours, due consideration shall be given to the location of air intakes/outlets and openings into accommodation, service and machinery spaces and control stations in relation to cargo piping, cargo vent systems and machinery space exhausts from gas burning arrangements.*

Compliance with the relevant requirements, in particular with [1.2.5], [1.8], Ch 9, Sec 8, [2.1.14] and Ch 9, Sec 12, [1.2.5], as applicable, also ensures compliance with this requirement, relevant to precautions against hazardous vapours.

1.2.4 *Access through doors, gastight or otherwise, shall not be permitted from a non-hazardous area to a hazardous area except for access to service spaces forward of the cargo area through airlocks, as permitted by [1.6.1], when accommodation spaces are aft.*

1.2.5 *Entrances, air inlets, air outlets and openings to accommodation spaces, service spaces, machinery spaces and control stations shall not face the cargo area. They shall be located on the end bulkhead not facing the cargo area or on the outboard side of the superstructure or deckhouse or on both at a distance of at least 4% of the length (L) of the ship but not less than 3 m from the end of the superstructure or deckhouse facing the cargo area. This distance, however, need not exceed 5 m.*

1.2.6 Doors facing the cargo area or located in prohibited zones in the sides are to be restricted to stores for cargo-related and safety equipment, cargo control stations as well as decontamination showers and eye wash.

Where such doors are permitted, the space may not give access to other spaces covered in [1.2.5], [1.2.8] or [1.2.10], and the common boundaries with these spaces are to be insulated with A60 class bulkheads.

The space define above is to be in accordance with Ch 9, Sec 12, [1.2].

1.2.7 Bolted plates of A60 class for removal of machinery may be accepted on bulkheads facing cargo areas, provided signboards are fitted to warn that these plates may only be opened when the ship is in gas-free condition.

1.2.8 *Windows and sidescuttles facing the cargo area and on the sides of the superstructures or deckhouses within the distance mentioned in [1.2.5] shall be of the fixed (non-opening) type. Wheelhouse windows may be non-fixed and wheelhouse doors may be located within the limits defined in [1.2.5] so long as they are designed in a manner that a rapid and efficient gas and vapour tightening of the wheelhouse can be ensured.*

1.2.9 *For ships dedicated to the carriage of cargoes that have neither flammable nor toxic hazards, the Society may approve relaxations from the above requirements.*

1.2.10 Accesses to forecastle spaces containing sources of ignition may be permitted through a single door facing the cargo area, provided the doors are located outside hazardous areas as defined in Ch 9, Sec 10.

1.2.11 *Windows and sidescuttles facing the cargo area and on the sides of the superstructures and deckhouses within the limits specified in [1.2.5], except wheelhouse windows, shall be constructed to "A-60" class. Sidescuttles in the shell below the uppermost continuous deck and in the first tier of the superstructure or deckhouse shall be of fixed (non-opening) type.*

1.2.12 *All air intakes, outlets and other openings into the accommodation spaces, service spaces and control stations shall be fitted with closing devices. When carrying toxic products, they shall be capable of being operated from inside the space. The requirement for fitting air intakes and openings with closing devices operated from inside the space for toxic products need not apply to spaces not normally manned, such as deck stores, forecastle stores, workshops. In addition, the requirement does not apply to cargo control rooms located within the cargo area.*

Note 1: The requirement for fitting air intakes and openings with closing devices operable from inside the space in ships intended to carry toxic products should apply to spaces which are used for the ships' radio and main navigating equipment, cabins, mess rooms, toilets, hospitals, galleys, etc., Engine room casings, cargo machinery spaces, electric motor rooms and steering gear compartments are generally considered as spaces not covered by this paragraph and therefore the requirement for closing devices need not be applied to these spaces.

When internal closing is required, this is to include both ventilation intakes and outlets.

The closing devices are to give a reasonable degree of gas-tightness. Ordinary steel fire-flaps without gaskets/seals are normally not considered satisfactory.

1.2.13 *Control rooms and machinery spaces of turret systems may be located in the cargo area forward or aft of cargo tanks in ships with such installations. Access to such spaces containing sources of ignition may be permitted through doors facing the cargo area, provided the doors are located outside hazardous areas or access is through airlocks.*

1.2.14 Access to the bow

Ships having the service notation **liquefied gas carrier** are to be provided with the means to enable the crew to gain safe access to the bow even in severe weather conditions. Such means of access are to be approved by the Society.

Note 1: The Society accepts means of access complying with the Guidelines for safe access to tanker bows adopted by the Marine Safety Committee of IMO by Resolution MSC.62 (67).

Note 2: The text printed in italic type in this requirement refers to the SOLAS Convention.

1.3 Cargo machinery spaces and turret compartments

1.3.1 Cargo pump rooms and/or cargo compressor rooms of ships carrying flammable gases may not contain electrical equipment, except as provided for in Ch 9, Sec 10, or other ignition sources such as internal combustion engines or steam engines with operating temperature which could cause ignition or explosion of mixtures of such gases, if any, with air.

1.3.2 *Cargo machinery spaces shall be situated above the weather deck and located within the cargo area. Cargo machinery spaces and turret compartments shall be treated as cargo pump-rooms for the purpose of fire protection according to SOLAS regulation II-2/9.2.4, and for the purpose of prevention of potential explosion according to SOLAS regulation II-2/4.5.10.*

1.3.3 *When cargo machinery spaces are located at the after end of the aftermost hold space or at the forward end of the foremost hold space, the limits of the cargo area, as defined in Ch 9, Sec 1, [4.1.8], shall be extended to include the cargo machinery spaces for the full breadth and depth of the ship and the deck areas above those spaces.*

1.3.4 *Where the limits of the cargo area are extended by [1.3.3], the bulkhead that separates the cargo machinery spaces from accommodation and service spaces, control stations and machinery spaces of category A shall be located so as to avoid the entry of gas to these spaces through a single failure of a deck or bulkhead.*

1.3.5 *Cargo compressors and cargo pumps may be driven by electric motors in an adjacent non-hazardous space separated by a bulkhead or deck, if the seal around the bulkhead penetration ensures effective gastight segregation of the two spaces. Alternatively, such equipment may be driven by certified safe electric motors adjacent to them if the electrical installation complies with the requirements of Ch 9, Sec 10.*

1.3.6 *Arrangements of cargo machinery spaces and turret compartments shall ensure safe unrestricted access for personnel wearing protective clothing and breathing apparatus, and in the event of injury to allow unconscious personnel to be removed. At least two widely separated escape routes and doors shall be provided in cargo machinery spaces, except that a single escape route may be accepted where the maximum travel distance to the door is 5 m or less.*

An emergency escape hatch with one vertical ladder may be accepted as an escape route if the vertical ladder does not interfere with the opening and closing of hatches and if hatches can be operated by one person, from either side, in both light and dark conditions. Moreover, hatch and vertical ladder are to ensure safe access for personnel wearing protective clothing and breathing apparatus.

1.3.7 *All valves necessary for cargo handling shall be readily accessible to personnel wearing protective clothing. Suitable arrangements shall be made to deal with drainage of pump and compressor rooms.*

1.3.8 *Turret compartments shall be designed to retain their structural integrity in case of explosion or uncontrolled high-pressure gas release (overpressure and/or brittle fracture), the characteristics of which shall be substantiated on the basis of a risk analysis with due consideration of the capabilities of the pressure relieving devices.*

1.4 Cargo control rooms

1.4.1 *Any cargo control room shall be above the weather deck and may be located in the cargo area. The cargo control room may be located within the accommodation spaces, service spaces or control stations, provided the following conditions are complied with:*

- *the cargo control room is a non-hazardous area*
- *if the entrance complies with [1.2.5], the control room may have access to the spaces described above, and*
- *if the entrance does not comply with [1.2.5], the cargo control room shall have no access to the spaces described above and the boundaries for such spaces shall be insulated to "A-60" class.*

1.4.2 *If the cargo control room is designed to be a non-hazardous area, instrumentation shall, as far as possible, be by indirect reading systems and shall, in any case, be designed to prevent any escape of gas into the atmosphere of that space. Location of the gas detection system within the cargo control room will not cause the room to be classified as a hazardous area, if installed in accordance with Ch 9, Sec 13, [6.1.11].*

1.4.3 *If the cargo control room for ships carrying flammable cargoes is classified as a hazardous area, sources of ignition shall be excluded and any electrical equipment shall be installed in accordance with Ch 9, Sec 10.*

1.5 Access to spaces in the cargo area

1.5.1 Designated passageways below and above cargo tanks are to have at least the cross-sections as specified in [1.5.6], item a).

1.5.2 Where fitted, cofferdams are to have sufficient size for easy access to all their parts. The width of the cofferdams may not be less than 600 mm.

1.5.3 Pipe tunnels are to have enough space to permit inspection of pipes. The pipes in pipe tunnels are to be installed as high as possible from the ship's bottom.

1.5.4 Visual inspection of at least one side of the inner hull structure shall be possible without the removal of any fixed structure or fitting. If such a visual inspection, whether combined with those inspections required in [1.5.5], Ch 9, Sec 4, [2.4.3] or Ch 9, Sec 4, [7.4.8] or not, is only possible at the outer face of the inner hull, the inner hull shall not be a fuel-oil tank boundary wall.

1.5.5 Inspection of one side of any insulation in hold spaces shall be possible. If the integrity of the insulation system can be verified by inspection of the outside of the hold space boundary when tanks are at service temperature, inspection of one side of the insulation in the hold space need not be required.

1.5.6 Arrangements for hold spaces, void spaces, cargo tanks and other spaces classified as hazardous areas, shall be such as to allow entry and inspection of any such space by personnel wearing protective clothing and breathing apparatus and shall also allow for the evacuation of injured and/or unconscious personnel. Such arrangements shall comply with the following:

a) Access shall be provided as follows:

- 1) access to all cargo tanks. Access shall be direct from the weather deck
- 2) access through horizontal openings hatches or manholes. The dimensions shall be sufficient to allow a person wearing a breathing apparatus to ascend or descend any ladder without obstruction, and also to provide a clear opening to facilitate the hoisting of an injured person from the bottom of the space. The minimum clear opening shall be not less than 600 mm x 600 mm.

The term “minimum clear opening of not less than 600 x 600 mm” means that such openings may have corner radii up to a maximum of 100 mm (see Fig 2). In such a case where as a consequence of structural analysis of a given design the stress is to be reduced around the opening, it is considered appropriate to take measures to reduce the stress such as making the opening larger with increased radii, e.g. 600 x 800 with 300 mm radii, in which a clear opening of 600 mm x 600 mm with corner radii up to 100 mm maximum fits.

- 3) access through vertical openings or manholes providing passage through the length and breadth of the space. The minimum clear opening shall be not less than 600 mm x 800 mm at a height of not more than 600 mm from the bottom plating unless gratings or other footholds are provided.

The term “minimum clear opening of not less than 600 x 800 mm” also includes an opening of the size specified in Fig 3.

Subject to verification of easy evacuation of injured person on a stretcher the vertical opening 850 mm x 620 mm with wider upper half than 600 mm, while the lower half may be less than 600 mm with the overall height not less than 850 mm is considered an acceptable alternative to the traditional opening of 600 mm x 800 mm with corner radii of 300 mm.

If a vertical opening is at a height of more than 600 mm steps and handgrips are to be provided. In such arrangements it is to be demonstrated that an injured person can be easily evacuated.

- 4) circular access openings to type C tanks shall have a diameter of not less than 600 mm.

Figure 2 : Minimum horizontal hatch size

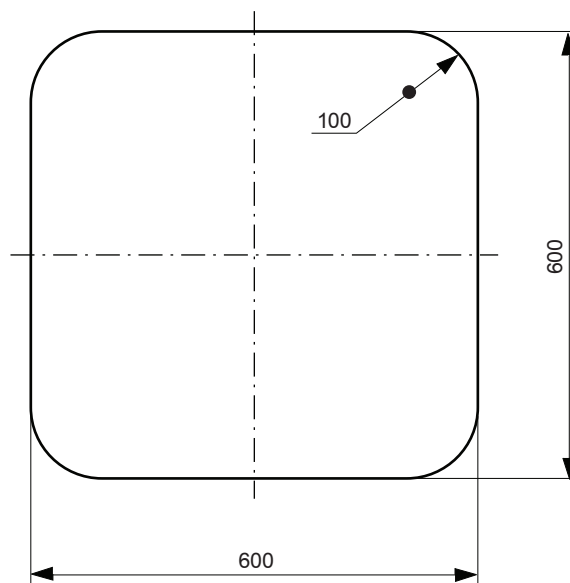
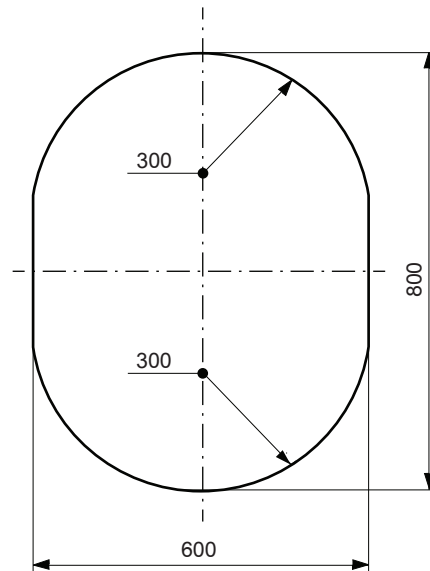
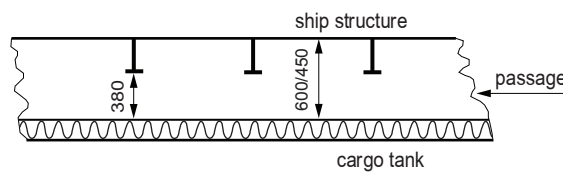

Figure 3 : Minimum size of manholes



- b) The dimensions referred to in [1.5.6], item a) 2) and [1.5.6] may be decreased, if the requirements of [1.5.6] can be met to the satisfaction of the Society.
- c) Where cargo is carried in a containment system requiring a secondary barrier, the requirements of [1.5.6], item a)2) and [1.5.6], item a)3) do not apply to spaces separated from a hold space by a single gastight steel boundary. Such spaces shall be provided only with direct or indirect access from the weather deck, not including any enclosed non-hazardous area.
- d) Access required for inspection shall be a designated access through structures below and above cargo tanks, which shall have at least the cross- sections as required by [1.5.6], item a)3).
- e) For the purpose of [1.5.4] or [1.5.5], the following shall apply:
 - 1) where it is required to pass between the surface to be inspected, flat or curved, and structures such as deck beams, stiffeners, frames, girders, etc., the distance between that surface and the free edge of the structural elements shall be at least 380 mm. The distance between the surface to be inspected and the surface to which the above structural elements are fitted, e.g. deck, bulkhead or shell, shall be at least 450 mm for a curved tank surface (e.g. for a type C tank), or 600 mm for a flat tank surface (e.g. for a type A tank) (see Fig 4)

Figure 4 :



- 2) where it is not required to pass between the surface to be inspected and any part of the structure, for visibility reasons the distance between the free edge of that structural element and the surface to be inspected shall be at least 50 mm or half the breadth of the structure's face plate, whichever is the larger (see Fig 5)

Figure 5 :

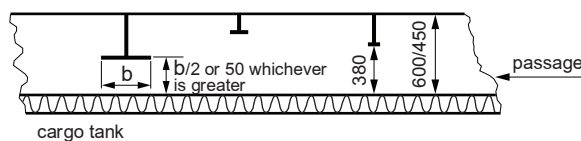

- 3) if for inspection of a curved surface where it is required to pass between that surface and another surface, flat or curved, to which no structural elements are fitted, the distance between both surfaces shall be at least 380 mm (see Fig 6). Where it is not required to pass between that curved surface and another surface, a smaller distance than 380 mm may be accepted taking into account the shape of the curved surface

Figure 6 :

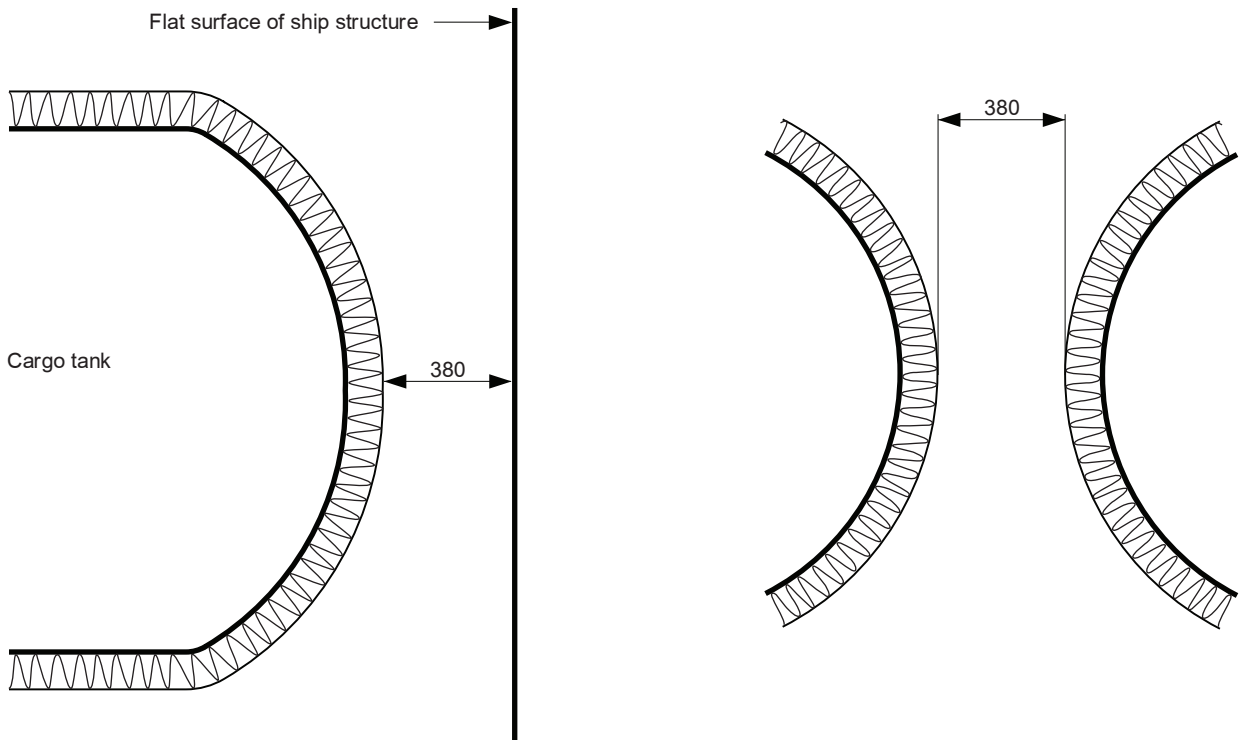

- 4) if for inspection of an approximately flat surface where it is required to pass between two approximately flat and approximately parallel surfaces, to which no structural elements are fitted, the distance between those surfaces shall be at least 600 mm. Where fixed access ladders are fitted, a clearance of at least 450 mm shall be provided for access (see Fig 7)

Figure 7 :

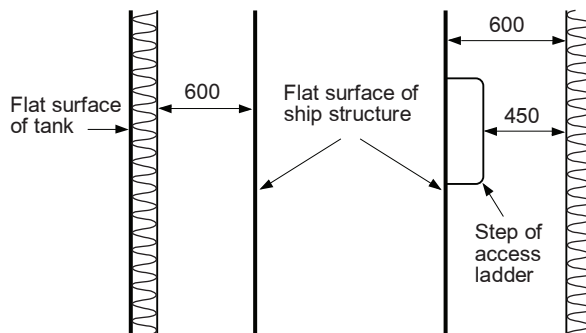

- 5) the minimum distances between a cargo tank sump and adjacent double bottom structure in way of a suction well shall not be less than those shown in Fig 8 (Fig 8 shows that the distance between the plane surfaces of the sump and the well is a minimum of 150 mm and that the clearance between the edge between the inner bottom plate, and the vertical side of the well and the knuckle point between the spherical or circular surface and sump of the tank is at least 380 mm). If there is no suction well, the distance between the cargo tank sump and the inner bottom shall not be less than 50 mm

Figure 8 :

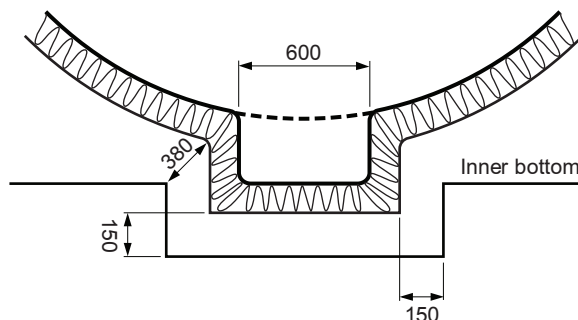

6) the distance between a cargo tank dome and deck structures shall not be less than 150 mm (see Fig 9)

Figure 9 :

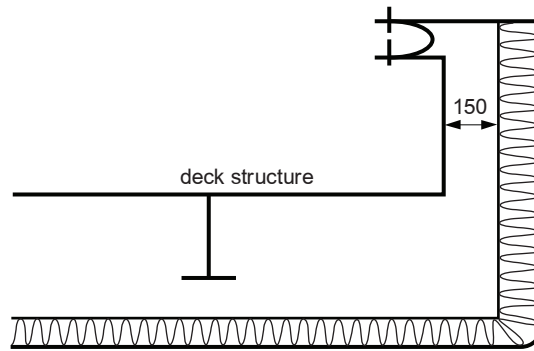

- 7) fixed or portable staging shall be installed as necessary for inspection of cargo tanks, cargo tank supports and restraints (e.g. anti-pitching, anti-rolling and anti-flotation chocks), cargo tank insulation etc. This staging shall not impair the clearances specified in [1.5.6], item e)1) to [1.5.6], item e) 4), and
- 8) if fixed or portable ventilation ducting shall be fitted in compliance with Ch 9, Sec 12, [1.2.2], such ducting shall not impair the distances required under [1.5.6], item e)1) to [1.5.6], item e) 4).

1.5.7 Access from the open weather deck to non-hazardous areas shall be located outside the hazardous areas as defined in Ch 9, Sec 10, unless the access is by means of an airlock in accordance with [1.6].

1.5.8 Turret compartments shall be arranged with two independent means of access/egress.

1.5.9 Access from a hazardous area below the weather deck to a non-hazardous area is not permitted.

1.6 Airlocks

1.6.1 Access between hazardous area on the open weather deck and non-hazardous spaces shall be by means of an airlock. This shall consist of two self-closing, substantially gastight, steel doors without any holding back arrangements, capable of maintaining the overpressure, at least 1,5 m but no more than 2,5 m apart. The airlock space shall be artificially ventilated from a non-hazardous area and maintained at an overpressure to the hazardous area on the weather deck.

1.6.2 Air-locks are to be such as to provide easy passage and are to cover a deck area of not less than 1,5 m². Air-locks are to be kept unobstructed and may not be employed for other uses, such as storage.

1.6.3 A differential pressure monitoring device shall be provided for monitoring the satisfactory functioning of pressurization of non-hazardous spaces protected by airlocks. Airflow sensors are considered an acceptable alternative in spaces having a ventilation rate not less than 30 air changes per hour.

In spaces where the ventilation rate is less than 30 air changes per hour and where airflow sensors are fitted as an alternative, in addition to the alarms required in [1.6.5], arrangements are to be made to de-energise electrical equipment which is not of the certified safe type if more than one airlock door is moved from the closed position.

1.6.4 Where spaces are protected by pressurization, the ventilation shall be designed and installed in accordance with recognized standards.

Note 1: Such as the recommended publication by the International Electrotechnical Commission, in particular IEC 60092-502:1999.

However, where the prescriptive requirements in the present Rules and IEC 60092-502 are not aligned, the prescriptive requirements in the present Rules take precedence and are to be applied.

1.6.5 An audible and visible alarm system to give a warning on both sides of the airlock shall be provided. The visible alarm shall indicate if one door is open. The audible alarm shall sound if doors on both sides of the airlock are moved from the closed positions.

The alarm systems are to be of the intrinsically safe type. However, signalling lamps may be of a safe type authorised for the dangerous spaces in which they are installed.

1.6.6 In ships carrying flammable products, electrical equipment that is located in spaces protected by airlocks and not of the certified safe type, shall be de-energized in case of loss of overpressure in the space.

1.6.7 Lack of overpressure or air flow is not to imply the stopping of motors driving compressors used for the boil-off system mentioned in Ch 9, Sec 16; therefore, such engines are to be of the certified safe type and the relevant control appliance is to be fitted in a non-gas-dangerous space.

The requirement above is not applicable if, during manoeuvring and operations in port, only fuel oil is used or when the automatic transfer from gas to fuel oil, as per Ch 9, Sec 16, [6.2], operates also when such electric motors are stopped without causing the shut-off of the boiler.

After any loss of the overpressure, the spaces protected by airlocks are to be ventilated for the time necessary to give at least 10 air changes prior to energising the non-safe type electrical installations.

1.6.8 *Electrical equipment for manoeuvring, anchoring and mooring, as well as emergency fire pumps that are located in spaces protected by airlocks, shall be of a certified safe type.*

1.6.9 *The airlock space shall be monitored for cargo vapours (see Ch 9, Sec 13, [6.1.2]).*

1.6.10 *Subject to the requirements of the International Convention on Load Lines in force, the door sill shall not be less than 300 mm in height.*

1.7 Bilge, ballast and oil fuel arrangements

1.7.1 Dry spaces within the cargo area are to be fitted with a bilge or drain arrangement not connected to the machinery space. Spaces not accessible at all times are to be fitted with sounding arrangements.

Spaces without a permanent ventilation system are to be fitted with a pressure/vacuum relief system or with air pipes.

1.7.2 Bilge arrangements for holds containing cargo tanks and for interbarrier spaces are to be operable from the weather deck.

1.7.3 The diameter of the bilge main may be smaller than the diameter specified in Pt C, Ch 1, Sec 10, [6.8.1], provided that this diameter is not less than twice the value given in Pt C, Ch 1, Sec 10, [6.8.3]. This reduction of diameter, however, is not applicable to the determination of the capacity of fire pumps according to Pt C, Ch 1, Sec 10, [6.7.4].

1.7.4 With reference to the means to ascertain leakages in holds and/or in interbarrier spaces, the following requirements apply:

- a) the above-mentioned means is to be suitable to ascertain the presence of water:
 - in holds containing type C independent tanks
 - in holds and interbarrier spaces outside the secondary barrier
- b) the above-mentioned means is to be suitable to ascertain the presence of liquid cargo in the spaces adjacent to cargo tanks which are not type C independent tanks.

Where the aforesaid spaces may be affected by water leakages from the adjacent ship structures, the means is also to be suitable to ascertain the presence of water.

Where the above-mentioned means is constituted by electrical level switches, the relevant circuits are to be of the intrinsically safe type and signals are to be transduced to the wheelhouse and to the cargo control station, if fitted.

1.7.5 *Where cargo is carried in a cargo containment system not requiring a secondary barrier, suitable drainage arrangements for the hold spaces that are not connected with the machinery space shall be provided. Means of detecting any leakage shall be provided.*

1.7.6 *Where there is a secondary barrier, suitable drainage arrangements for dealing with any leakage into the hold or insulation spaces through the adjacent ship structure shall be provided. The suction shall not lead to pumps inside the machinery space. Means of detecting such leakage shall be provided.*

1.7.7 *The hold or interbarrier spaces of type A independent tank ships shall be provided with a drainage system suitable for handling liquid cargo in the event of cargo tank leakage or rupture. Such arrangements shall provide for the return of any cargo leakage to the liquid cargo piping.*

1.7.8 *Arrangements referred to in [1.7.7] shall be provided with a removable spool piece.*

1.7.9 *Ballast spaces, including wet duct keels used as ballast piping, oil fuel tanks and non-hazardous spaces, may be connected to pumps in the machinery spaces. Dry duct keels with ballast piping passing through may be connected to pumps in the machinery spaces, provided the connections are led directly to the pumps, and the discharge from the pumps is led directly overboard with no valves or manifolds in either line that could connect the line from the duct keel to lines serving non-hazardous spaces. Pump vents shall not be open to machinery spaces.*

Note 1: For ballast tanks separated by a single gastight boundary from cargo tanks for which no secondary barrier is required - e.g. ballast tanks adjacent to integral tanks -, discharge arrangements are to be outside machinery spaces and accommodation spaces but filling arrangements may be in the machinery spaces provided that such arrangements ensure filling from tank deck level and a non-return valve and removable spool piece are fitted.

Note 2: The requirements of "Pump vents should not be open to machinery spaces" and "Pump vents shall not be open to machinery spaces" apply only to pumps in the machinery spaces serving dry duct keels through which ballast piping passes.

1.8 Bow and stern loading and unloading arrangements

1.8.1 *Subject to the requirements of this section and Ch 9, Sec 5, cargo piping may be arranged to permit bow or stern loading and unloading.*

1.8.2 Bow or stern loading and unloading lines that are led past accommodation spaces, service spaces or control stations shall not be used for the transfer of products requiring a type 1G ship. Bow or stern loading and unloading lines shall not be used for the transfer of toxic products as specified in Ch 9, Sec 1, [4.1.51], where the design pressure is above 2,5 MPa.

1.8.3 Portable arrangements shall not be permitted.

1.8.4

- a) Entrances, air inlets, air outlets and openings to accommodation spaces, service spaces, machinery spaces and controls stations, shall not face the cargo shore connection location of bow or stern loading and unloading arrangements. They shall be located on the outboard side of the superstructure or deckhouse at a distance of at least 4% of the length of the ship, but not less than 3 m from the end of the superstructure or deckhouse facing the cargo shore connection location of the bow or stern loading and unloading arrangements.
- b) Windows and sides cuttles facing the shore connection location and on the sides of the superstructure or deckhouse within the distance mentioned above shall be of the fixed (non-opening) type.
- c) In addition, during the use of the bow or stern loading and unloading arrangements, all doors, ports and other openings on the corresponding superstructure or deckhouse side shall be kept closed.
- d) Where, in the case of small ships, compliance with [1.2.5] and [1.8.4] is not possible, the Society may approve relaxations from the above requirements.

1.8.5 Deck openings and air inlets and outlets to spaces within distances of 10 m from the cargo shore connection location shall be kept closed during the use of bow or stern loading or unloading arrangements.

1.8.6 Fire fighting arrangements for the bow or stern loading and unloading areas shall be in accordance with Ch 9, Sec 11, [1.3.2], item d) and Ch 9, Sec 11, [1.4.7].

1.8.7 Devices to stop cargo pumps and cargo compressors and to close cargo valves are to be fitted in a position from which it is possible to keep under control the loading/unloading manifolds.

1.8.8 Means of communication between the cargo control station and the shore connection location shall be provided and, where applicable, certified for use in hazardous areas.

1.9 Emergency towing arrangements

1.9.1 The requirements of Pt B, Ch 12, Sec 4, [3] are to be complied with on ships of not less than 20000 t deadweight.

Section 4 Cargo Containment

Symbols

R_{eH}	: Minimum yield stress, in N/mm ² , of the material, defined in Pt B, Ch 4, Sec 1
R_m	: Minimum ultimate tensile strength, in N/mm ² , of the material
R_y	: Minimum yield stress, in N/mm ² , of the material, to be taken equal to 235/k N/mm ² , unless otherwise specified
k	: Material factor for steel, defined in Pt B, Ch 4, Sec 1, [4.4]
s	: Spacing, in mm, of ordinary stiffeners
d_{shr}	: Effective shear depth, in mm, as defined in Pt B, Ch 4, Sec 6, [1.4.4]
l_{bdg}	: Effective bending span, in m, of ordinary stiffeners defined in Pt B, Ch 4, Sec 6
l_{shr}	: Effective shear span, in m, of ordinary stiffeners defined in Pt B, Ch 4, Sec 6
α_p	: Correction factor for the panel aspect ratio, to be taken as follows: $\alpha_p = 1,2 - \frac{b}{2,1 a}$ to be taken not greater than 1,0
b	: Breadth of plate panel, in mm, as defined in Pt B, Ch 4, Sec 6, [2.1.1]
T_{SC}	: Scantling draught, in m, defined in Pt B, Ch 1, Sec 3, [2.1.6].

1 General

1.1 Scope

1.1.1 *The purpose of this Section is to ensure the safe containment of cargo under all design and operating conditions having regard to the nature of the cargo carried. This will include measures to:*

- provide strength to withstand defined loads
- maintain the cargo in a liquid state
- design for or protect the hull structure from low temperature exposure
- prevent the ingress of water or air into the cargo containment system.

1.1.2 This Section is not applicable to:

- liquefied natural gas (LNG) membrane tanks which are to comply with Ch 9, Sec 20 and NR686
- Ships carrying products defined in Ch 9, Sec 19, with the exception of LNG, and equipped with membrane tank which are to comply with Article [11], Ch 9, Sec 20 and NR686.

1.2 Definitions

1.2.1 *A cold spot is a part of the hull or thermal insulation surface where a localized temperature decrease occurs with respect to the allowable minimum temperature of the hull or of its adjacent hull structure, or to design capabilities of cargo pressure/temperature control systems required in Ch 9, Sec 7.*

1.2.2 *Design vapour pressure P_0 is the maximum gauge pressure, at the top of the tank, to be used in the design of the tank.*

1.2.3 *Design temperature for selection of materials is the minimum temperature at which cargo may be loaded or transported in the cargo tanks.*

1.2.4 *Independent tanks are self-supporting tanks. They do not form part of the ship's hull and are not essential to the hull strength. There are three categories of independent tank, which are referred to in [8], [9] and [10].*

1.2.5 *Integral tanks are tanks that form a structural part of the hull and are influenced in the same manner by the loads that stress the adjacent hull structure. Integral tanks are covered in [12].*

1.2.6 *Semi-membrane tanks are non-self-supporting tanks in the loaded condition and consist of a layer, parts of which are supported through insulation by the adjacent hull structure. Semi-membrane tanks are covered in [13].*

1.2.7 *In addition to the definitions given in Ch 9, Sec 1, the definitions given in this Section shall apply throughout Part D, Chapter 9.*

1.3 Application

1.3.1 Unless otherwise specified in [8] to [13], the requirements of [2] to [6] and Ch 9, Sec 20 shall apply to all types of tanks described in this Section, including those covered in [14].

2 Cargo containment

2.1 Functional requirement

2.1.1 The design life of the cargo containment system shall not be less than the design life of the ship.

2.1.2 Cargo containment systems shall be designed for North Atlantic environmental conditions and relevant long-term sea state scatter diagrams for unrestricted navigation. Lesser environmental conditions, consistent with the expected usage, may be accepted by the Society for cargo containment systems used exclusively for restricted navigation. Greater environmental conditions may be required for cargo containment systems operated in conditions more severe than the North Atlantic environment.

2.1.3 Cargo containment systems shall be designed with suitable safety margins:

- to withstand, in the intact condition, the environmental conditions anticipated for the cargo containment system's design life and the loading conditions appropriate for them, which include full homogeneous and partial load conditions, partial filling within defined limits and ballast voyage loads; and
- being appropriate for uncertainties in loads, structural modeling, fatigue, corrosion, thermal effects, material variability, ageing and construction tolerances.

2.1.4 The cargo containment system structural strength shall be assessed against failure modes, including but not limited to plastic deformation, buckling and fatigue. The specific design conditions which shall be considered for the design of each cargo containment system are given in [8] to [13]. There are three main categories of design conditions:

- a) Ultimate design conditions – the cargo containment system structure and its structural components shall withstand loads liable to occur during its construction, testing and anticipated use in service, without loss of structural integrity. The design shall take into account proper combinations of the following loads:
 - internal pressure
 - external pressure
 - dynamic loads due to the motion of the ship
 - thermal loads
 - sloshing loads
 - loads corresponding to ship deflections
 - tank and cargo weight with the corresponding reaction in way of supports
 - insulation weight
 - loads in way of towers and other attachments; and
 - test loads.
- b) Fatigue design conditions – the cargo containment system structure and its structural components shall not fail under accumulated cyclic loading.
- c) Accident design condition:

The cargo containment system shall meet the following criteria:

 - Collision: the cargo containment system shall be protectively located in accordance with Ch 9, Sec 2, [4.1.1] and withstand the collision loads specified in [3.5.2] without deformation of the supports, or the tank structure in way of the supports, likely to endanger the tank structure.
 - Fire: the cargo containment systems shall sustain, without rupture, the rise in internal pressure specified in Ch 9, Sec 8, [4.1] under the fire scenarios envisaged therein.
 - Flooded compartment causing buoyancy on tank: the anti-flotation arrangements shall sustain the upward force, specified in [3.5.3], and there shall be no endangering plastic deformation to the hull.
 - 30° heel scenario: the cargo containment systems shall sustain, without rupture, a static angle of heel of 30°.

2.1.5 Measures shall be applied to ensure that scantlings required meet the structural strength provisions and be maintained throughout the design life. Measures may include, but are not limited to, material selection, coatings, corrosion additions, cathodic protection and inerting. Corrosion allowance need not be required in addition to the thickness resulting from the structural analysis. However, where there is no environmental control, such as inerting around the cargo tank, or where the cargo is of a corrosive nature, the Society may require a suitable corrosion allowance.

2.1.6 An inspection/survey plan for the cargo containment system shall be developed and approved by the Society. The inspection/survey plan shall identify areas that need inspection during surveys throughout the cargo containment system's life and, in particular, all necessary in-service survey and maintenance that was assumed when selecting cargo containment system

design parameters. Cargo containment systems shall be designed, constructed and equipped to provide adequate means of access to areas that need inspection as specified in the inspection/survey plan. Cargo containment systems, including all associated internal equipment, shall be designed and built to ensure safety during operations, inspection and maintenance (see Ch 9, Sec 3, [1.5]).

2.2 Cargo containment safety principles

2.2.1 The containment systems shall be provided with a full secondary liquid-tight barrier capable of safely containing all potential leakages through the primary barrier and, in conjunction with the thermal insulation system, of preventing lowering of the temperature of the ship structure to an unsafe level.

2.2.2 However, the size and configuration or arrangement of the secondary barrier may be reduced where an equivalent level of safety is demonstrated in accordance with the requirements of [2.2.3] to [2.2.5], as applicable.

2.2.3 Cargo containment systems for which the probability for structural failures to develop into a critical state has been determined to be extremely low, but where the possibility of leakages through the primary barrier cannot be excluded, shall be equipped with a partial secondary barrier and small leak protection system capable of safely handling and disposing of the leakages. The arrangements shall comply with the following requirements:

- failure developments that can be reliably detected before reaching a critical state (e.g. by gas detection or inspection) shall have a sufficiently long development time for remedial actions to be taken; and
- failure developments that cannot be safely detected before reaching a critical state shall have a predicted development time that is much longer than the expected lifetime of the tank.

2.2.4 No secondary barrier is required for cargo containment systems, e.g. type C independent tanks, where the probability for structural failures and leakages through the primary barrier is extremely low and can be neglected.

2.2.5 No secondary barrier is required where the cargo temperature at atmospheric pressure is at or above – 10°C.

2.3 Secondary barriers in relation to tank types

2.3.1 Secondary barriers in relation to the tank types defined in [8] to [13] shall be provided in accordance with Tab 1.

Table 1 : Secondary barriers in relation to tank types

Cargo temperature at atmospheric pressure		–10°C and above	Below –10°C down to –55°C	Below –55°C
Basic tank type		No secondary barrier required	Hull may act as secondary barrier	Separate secondary barrier where required
Integral			Tank type not normally allowed (1)	
Semi-membrane			Complete secondary barrier (2)	
Independent	type A		Complete secondary barrier	
	type B	Partial secondary barrier		
	type C	No secondary barrier required		
<p>(1) A complete secondary barrier shall normally be required if cargoes with a temperature at atmospheric pressure below -10°C are permitted in accordance with [12.1].</p> <p>(2) In the case of semi-membrane tanks that comply in all respects with the requirements applicable to type B independent tanks, except for the manner of support, the Society may, after special consideration, accept a partial secondary barrier.</p>				

2.4 Design of secondary barriers

2.4.1 Secondary barrier extent

The extent of the secondary barrier is to be not less than that necessary to protect the hull structures assuming that the cargo tank is breached at a static angle of heel of 30°, with an equalisation of the liquid cargo in the tank (see Fig 1).

Note 1: The “liquid level” given in Fig 1 is considered at the maximum allowable filling level in the cargo tank

2.4.2 Where the cargo temperature at atmospheric pressure is not below – 55°C, the hull structure may act as a secondary barrier based on the following:

- the hull material shall be suitable for the cargo temperature at atmospheric pressure as required by [5.2.4]; and
- the design shall be such that this temperature will not result in unacceptable hull stresses.

2.4.3 The design of the secondary barrier shall be such that:

- a) It is capable of containing any envisaged leakage of liquid cargo for a period of 15 days, unless different criteria apply for particular voyages, taking into account the load spectrum referred to in [4.6.6]
- b) Physical, mechanical, or operational events within the cargo tank that could cause failure of the primary barrier shall not impair the due function of the secondary barrier, or vice versa
- c) Failure of a support or an attachment to the hull structure will not lead to loss of liquid tightness of both the primary and secondary barriers
- d) It is capable of being periodically checked for its effectiveness by means acceptable to the Society. This may be by means of a visual inspection or a pressure/vacuum test or other suitable means carried out according to a documented procedure agreed with the Society. Requirements for tightness tests of secondary barriers are detailed in [6.4.4].
- e) The methods required in item d) shall be approved by the Society and shall include, where applicable to the test procedure:
 - details on the size of defect acceptable and the location within the secondary barrier, before its liquid-tight effectiveness is compromised
 - accuracy and range of values of the proposed method for detecting defects in item a)
 - scaling factors to be used in determining the acceptance criteria, if full scale model testing is not undertaken; and
 - effects of thermal and mechanical cyclic loading on the effectiveness of the proposed test; and
- f) The secondary barrier shall fulfil its functional requirements at a static angle of heel of 30°.

Figure 1 : Secondary barrier extension

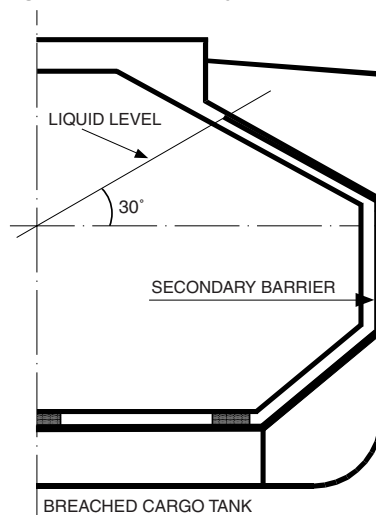

2.5 Partial secondary barriers and primary barrier small leak protection system

2.5.1 Partial secondary barriers as permitted in [2.2.3] shall be used with a small leak protection system and meet all the requirements in [2.4.3]. The small leak protection system shall include means to detect a leak in the primary barrier, provision such as a spray shield to deflect any liquid cargo down into the partial secondary barrier, and means to dispose of the liquid, which may be by natural evaporation.

2.5.2 The capacity of the partial secondary barrier shall be determined, based on the cargo leakage corresponding to the extent of failure resulting from the load spectrum referred to in [4.6.6], after the initial detection of a primary leak. Due account may be taken of liquid evaporation, rate of leakage, pumping capacity and other relevant factors.

2.5.3 The required liquid leakage detection may be by means of liquid sensors, or by an effective use of pressure, temperature or gas detection systems, or any combination thereof.

2.6 Supporting arrangements

2.6.1 The supporting arrangements are to comply with the requirements defined in [7.1].

2.7 Associated structure and equipment

2.7.1 Cargo containment systems shall be designed for the loads imposed by associated structure and equipment. This includes pump towers, cargo domes, cargo pumps and piping, stripping pumps and piping, nitrogen piping, access hatches, ladders, piping penetrations, liquid level gauges, independent level alarm gauges, spray nozzles, and instrumentation systems (such as pressure, temperature and strain gauges).

2.8 Thermal insulation

2.8.1 *Thermal insulation shall be provided, as required, to protect the hull from temperatures below those allowable (see [5.2]) and limit the heat flux into the tank to the levels that can be maintained by the pressure and temperature control system applied in Ch 9, Sec 7.*

2.8.2 *In determining the insulation performance, due regard shall be given to the amount of the acceptable boil-off in association with the reliquefaction plant on board, main propulsion machinery or other temperature control system.*

2.9 Use of cargo heater to raise the cargo temperature

2.9.1 Where a cargo heater, intended to raise the cargo temperature to a value permissible for cargo tanks, is envisaged, the following requirements are to be complied with:

- the piping and valves involved are to be suitable for the design loading temperature
- a thermometer is to be fitted at the heater outlet. It is to be set at the design temperature of the tanks and, when activated, it is to give a visual and audible alarm. This alarm is to be installed in the cargo control station or, when such a station is not foreseen, in the wheelhouse.
- the following note is to be written on the Certificate of Fitness: "The minimum permissible temperature in the cargo preheater is..... °C".

3 Design loads

3.1 General

3.1.1 *This section defines the design loads to be considered with regard to the requirements in [4]. This includes:*

- *load categories (permanent, functional, environmental and accidental) and the description of the loads;*
- *the extent to which these loads shall be considered depending on the type of tank, and is more fully detailed in the following paragraphs; and*
- *tanks, together with their supporting structure and other fixtures, that shall be designed taking into account relevant combinations of the loads described below.*

3.2 Permanent loads

3.2.1 Gravity loads

The weight of tank, thermal insulation, loads caused by towers and other attachments shall be considered.

3.2.2 Permanent external loads

Gravity loads of structures and equipment acting externally on the tank shall be considered.

3.3 Functional loads

3.3.1 *Loads arising from the operational use of the tank system shall be classified as functional loads. All functional loads that are essential for ensuring the integrity of the tank system, during all design conditions, shall be considered. As a minimum, the effects from the following criteria, as applicable, shall be considered when establishing functional loads:*

- *internal pressure*
- *external pressure*
- *thermally induced loads*
- *vibration*
- *interaction loads*
- *loads associated with construction and installation*
- *test loads*
- *static heel loads; and*
- *weight of cargo.*

3.3.2 Internal pressure

- a) *In all cases, including item b), P_o shall not be less than MARVS.*
- b) *For cargo tanks, where there is no temperature control and where the pressure of the cargo is dictated only by the ambient temperature, P_o shall not be less than the gauge vapour pressure of the cargo at a temperature of 45°C except as follows:*
- lower values of ambient temperature may be accepted by the Society for ships operating in restricted areas. Conversely, higher values of ambient temperature may be required; and*
 - for ships on voyages of restricted duration, P_o may be calculated based on the actual pressure rise during the voyage, and account may be taken of any thermal insulation of the tank.*
- c) *Subject to special consideration by the Society and to the limitations given in [8] to [13], for the various tank types, a vapour pressure P_h higher than P_o may be accepted for site specific conditions (harbour or other locations), where dynamic loads are reduced. Any relief valve setting resulting from this paragraph shall be recorded in the International Certificate of Fitness for the Carriage of Liquefied Gases in Bulk.*
- d) *Where the vapour pressure in harbour conditions is greater than P_{or} , defined in [1.2.2], this value is to be specified in the operating instructions for the ship's Master.*
- e) *The internal pressure P_{eq} results from the vapour pressure P_o or P_h plus the maximum associated dynamic liquid pressure P_{gdr} , but not including the effects of liquid sloshing loads. Guidance formulae for associated dynamic liquid pressure P_{gd} are given in Ch 9, App 1, [1.1].*
- f) *The internal pressure to be considered for integral tanks is defined in Ch 9, App 1, [2].*

3.3.3 External pressure

External design pressure loads shall be based on the difference between the minimum internal pressure and the maximum external pressure to which any portion of the tank may be simultaneously subjected.

3.3.4 Thermally induced loads

Transient thermally induced loads during cooling down periods shall be considered for tanks intended for cargo temperatures below – 55°C.

Stationary thermally induced loads shall be considered for cargo containment systems where the design supporting arrangements or attachments and operating temperature may give rise to significant thermal stresses (see Ch 9, Sec 7, [2]).

3.3.5 Vibration

The potentially damaging effects of vibration on the cargo containment system shall be considered.

3.3.6 Interaction loads

The static component of loads resulting from interaction between cargo containment system and the hull structure, as well as loads from associated structure and equipment, shall be considered.

3.3.7 Loads associated with construction and installation

Loads or conditions associated with construction and installation, e.g. lifting, shall be considered.

3.3.8 Test loads

Account shall be taken of the loads corresponding to the testing of the cargo containment system referred to in [8] to [13].

3.3.9 Static heel loads

Loads corresponding to the most unfavourable static heel angle within the range 0° to 30° shall be considered.

Guidance for calculation of static pressure for 30° heel angle is given in Ch 9, App 1, [3].

3.3.10 Other loads

Any other loads not specifically addressed, which could have an effect on the cargo containment system, shall be taken into account.

3.4 Environmental loads

3.4.1 Definition

Environmental loads are defined as those loads on the cargo containment system that are caused by the surrounding environment and that are not otherwise classified as a permanent, functional or accidental load.

3.4.2 Loads due to ship motion

- a) *The determination of dynamic loads shall take into account the long-term distribution of ship motion in irregular seas, which the ship will experience during its operating life. Account may be taken of the reduction in dynamic loads due to necessary speed reduction and variation of heading.*
- b) *The ship's motion shall include surge, sway, heave, roll, pitch and yaw. The accelerations acting on tanks shall be estimated at their centre of gravity and include the following components:*
- *vertical acceleration: motion accelerations of heave, pitch and, possibly, roll (normal to the ship base);*
 - *transverse acceleration: motion accelerations of sway, yaw and roll and gravity component of roll; and*
 - *longitudinal acceleration: motion accelerations of surge and pitch and gravity component of pitch.*
- c) *Methods to predict accelerations due to ship motion shall be proposed and approved by the Society.*
- d) *Guidance formulae for acceleration components are given in Ch 9, App 1, [1.2].*
- e) *Ships for restricted service may be given special consideration.*

3.4.3 Dynamic interaction loads

Account shall be taken of the dynamic component of loads resulting from interaction between cargo containment systems and the hull structure, including loads from associated structures and equipment.

3.4.4 Sloshing loads

The sloshing loads on a cargo containment system and internal components shall be evaluated based on allowable filling levels. When significant sloshing-induced loads are expected to be present, special tests and calculations shall be required covering the full range of intended filling levels.

For type C tanks where suitable wash bulkheads are installed, sloshing loads may be disregarded.

Guidance for calculation of sloshing pressure for integral tanks is given in NR686, App 1, [2.2].

3.4.5 Snow and ice loads

Snow and icing shall be considered, if relevant.

3.4.6 Loads due to navigation in ice

Loads due to navigation in ice shall be considered for vessels intended for such service.

3.5 Accidental loads

3.5.1 Definition

Accidental loads are defined as loads that are imposed on a cargo containment system and its supporting arrangements under abnormal and unplanned conditions.

3.5.2 Collision loads

The collision load shall be determined based on the cargo containment system under fully loaded condition with an inertial force corresponding to 0,5 g in the forward direction and 0,25 g in the aft direction, where g is gravitational acceleration.

Guidance for calculation of dynamic pressure, to be considered in addition to static pressure, is given in Ch 9, App 1, [4]

3.5.3 Loads due to flooding on ship

For independent tanks, loads caused by the buoyancy of an empty tank in a hold space flooded to the summer load draught shall be considered in the design of the anti-flotation chocks and the supporting hull structure.

4 Structural integrity

4.1 General

4.1.1 *The structural design shall ensure that tanks have an adequate capacity to sustain all relevant loads with an adequate margin of safety. This shall take into account the possibility of plastic deformation, buckling, fatigue and loss of liquid and gas tightness*

4.1.2 *The structural integrity of cargo containment systems shall be demonstrated by compliance with [8] to [13], as appropriate, for the cargo containment system type.*

4.1.3 *The structural integrity of cargo containment system types that are of novel design and differ significantly from those covered by [8] to [13] shall be demonstrated by compliance with [14] to ensure that the overall level of safety provided in this Section is maintained.*

4.2 Structural analyses

4.2.1 Analysis

- The design analyses shall be based on accepted principles of statics, dynamics and strength of materials.
- Simplified methods or simplified analyses may be used to calculate the load effects, provided that they are conservative. Model tests may be used in combination with, or instead of, theoretical calculations. In cases where theoretical methods are inadequate, model or full-scale tests may be required.
- When determining responses to dynamic loads, the dynamic effect shall be taken into account where it may affect structural integrity.

4.2.2 Load scenarios

- For each location or part of the cargo containment system to be considered and for each possible mode of failure to be analysed, all relevant combinations of loads that may act simultaneously shall be considered.
- The most unfavourable scenarios for all relevant phases during construction, handling, testing and in service, and conditions shall be considered.

4.2.3 When the static and dynamic stresses are calculated separately, and unless other methods of calculation are justified, the total stresses shall be calculated according to:

$$\sigma_x = \sigma_{x,st} \pm \sqrt{\sum (\sigma_{x,dyn})^2}$$

$$\sigma_y = \sigma_{y,st} \pm \sqrt{\sum (\sigma_{y,dyn})^2}$$

$$\sigma_z = \sigma_{z,st} \pm \sqrt{\sum (\sigma_{z,dyn})^2}$$

$$\tau_{xy} = \tau_{xy,st} \pm \sqrt{\sum (\tau_{xy,dyn})^2}$$

$$\tau_{xz} = \tau_{xz,st} \pm \sqrt{\sum (\tau_{xz,dyn})^2}$$

$$\tau_{yz} = \tau_{yz,st} \pm \sqrt{\sum (\tau_{yz,dyn})^2}$$

where:

$\sigma_{x,st}$, $\sigma_{y,st}$, $\sigma_{z,st}$, $\tau_{xy,st}$, $\tau_{xz,st}$ and $\tau_{yz,st}$ are static stresses; and

$\sigma_{x,dyn}$, $\sigma_{y,dyn}$, $\sigma_{z,dyn}$, $\tau_{xy,dyn}$, $\tau_{xz,dyn}$ and $\tau_{yz,dyn}$ are dynamic stresses,

each shall be determined separately from acceleration components and hull strain components due to deflection and torsion.

4.3 Stress categories

4.3.1 For the purpose of stress evaluation, stress categories are defined in this section as follows:

- Normal stress is the component of stress normal to the plane of reference.
- Membrane stress is the component of normal stress that is uniformly distributed and equal to the average value of the stress across the thickness of the section under consideration.
- Bending stress is the variable stress across the thickness of the section under consideration, after the subtraction of the membrane stress.
- Shear stress is the component of the stress acting in the plane of reference.
- Primary stress is a stress produced by the imposed loading, which is necessary to balance the external forces and moments. The basic characteristic of a primary stress is that it is not self-limiting. Primary stresses that considerably exceed the yield strength will result in failure or at least in gross deformations.
- Primary general membrane stress is a primary membrane stress that is so distributed in the structure that no redistribution of load occurs as a result of yielding.
- Primary local membrane stress arises where a membrane stress produced by pressure or other mechanical loading and associated with a primary or a discontinuity effect produces excessive distortion in the transfer of loads for other portions of the structure. Such a stress is classified as a primary local membrane stress, although it has some characteristics of a secondary stress. A stress region may be considered as local, if:

$$S_1 \leq 0,5 \sqrt{Rt}$$

$$S_2 \geq 2,5 \sqrt{Rt}$$

where:

- S_1 : Distance in the meridional direction over which the equivalent stress exceeds $1,1 f$
- S_2 : Distance in the meridional direction to another region where the limits for primary general membrane stress are exceeded
- R : Mean radius of the vessel
- t : Wall thickness of the vessel at the location where the primary general membrane stress limit is exceeded; and
- f : Allowable primary general membrane stress.

- Secondary stress is a normal stress or shear stress developed by constraints of adjacent parts or by self-constraint of a structure. The basic characteristic of a secondary stress is that it is self-limiting. Local yielding and minor distortions can satisfy the conditions that cause the stress to occur.

4.4 Design conditions

4.4.1 All relevant failure modes shall be considered in the design for all relevant load scenarios and design conditions. The design conditions are given in [4.5] to [4.7], and the load scenarios are covered by [4.2.2].

4.5 Ultimate design condition

4.5.1 Structural capacity may be determined by testing, or by analysis, taking into account both the elastic and plastic material properties, by simplified linear elastic analysis or by the Code provisions.

- a) Plastic deformation and buckling shall be considered.
- b) Analysis shall be based on characteristic load values as follows:
 - permanent loads: expected values
 - functional loads: specified values
 - environmental loads: for wave loads: most probable largest load encountered during 10^8 wave encounters.
- c) For the purpose of ultimate strength assessment, the following material parameters apply:
 - R_e = specified minimum yield stress at room temperature (N/mm^2). If the stress-strain curve does not show a defined yield stress, the 0.2% proof stress applies.
 - R_m = specified minimum tensile strength at room temperature (N/mm^2).

For welded connections where under-matched welds, i.e. where the weld metal has lower tensile strength than the parent metal, are unavoidable, such as in some aluminium alloys, the respective R_e and R_m of the welds, after any applied heat treatment, shall be used. In such cases, the transverse weld tensile strength shall not be less than the actual yield strength of the parent metal. If this cannot be achieved, welded structures made from such materials shall not be incorporated in cargo containment systems.

The above properties shall correspond to the minimum specified mechanical properties of the material, including the weld metal in the as-fabricated condition. Subject to special consideration by the Society, account may be taken of the enhanced yield stress and tensile strength at low temperature. The temperature on which the material properties are based shall be shown on the International Certificate of Fitness for the Carriage of Liquefied Gases in Bulk.

- d) The equivalent stress σ_C (von Mises, Huber) shall be determined by:

$$\sigma_C = \sqrt{\sigma_x^2 + \sigma_y^2 + \sigma_z^2 - \sigma_x\sigma_y - \sigma_x\sigma_z - \sigma_y\sigma_z + 3(\tau_{xz}^2 + \tau_{xy}^2 + \tau_{yz}^2)}$$

where:

- σ_x : Total normal stress in x-direction
- σ_y : Total normal stress in y-direction
- σ_z : Total normal stress in z-direction
- τ_{xy} : Total shear stress in x-y plane
- τ_{xz} : Total shear stress in x-z plane; and
- τ_{yz} : Total shear stress in y-z plane.

The above values shall be calculated as described in [4.2.3].

- e) Allowable stresses for materials other than those covered by Ch 9, Sec 6 shall be subject to approval by the Society in each case.
- f) Stresses may be further limited by fatigue analysis, crack propagation analysis and buckling criteria.

4.6 Fatigue design condition

4.6.1 The fatigue design condition is the design condition with respect to accumulated cyclic loading.

4.6.2 Where a fatigue analysis is required, the cumulative effect of the fatigue load shall comply with:

$$\sum \frac{n_i}{N_i} + \frac{n_{\text{Loading}}}{N_{\text{Loading}}} \leq C_w$$

where:

- n_i : Number of stress cycles at each stress level during the life of the tank
- N_i : Number of cycles to fracture for the respective stress level according to the Wohler (S-N) curve
- $n_{Loading}$: Number of loading and unloading cycles during the life of the tank, not to be less than 1000. Loading and unloading cycles include a complete pressure and thermal cycle

Note 1: 1000 cycles normally corresponds to 20 years of operation.

- $N_{Loading}$: Number of cycles to fracture for the fatigue loads due to loading and unloading; and
- C_w : Maximum allowable cumulative fatigue damage ratio.

The fatigue damage shall be based on the design life of the tank but not less than 10^8 wave encounters.

4.6.3 Where required, the cargo containment system shall be subject to fatigue analysis, considering all fatigue loads and their appropriate combinations for the expected life of the cargo containment system. Consideration shall be given to various filling conditions.

4.6.4

- a) Design S-N curves used in the analysis shall be applicable to the materials and weldments, construction details, fabrication procedures and applicable state of the stress envisioned.
- b) The S-N curves shall be based on a 97,6% probability of survival corresponding to the mean-minus-two-standard-deviation curves of relevant experimental data up to final failure. Use of S-N curves derived in a different way requires adjustments to the acceptable C_w values specified in [4.6.7] to [4.6.9].

4.6.5 Analysis shall be based on characteristic load values as follows:

- permanent loads: expected values
- functional loads: specified values or specified history
- environmental loads: expected load history, but not less than 10^8 cycles

If simplified dynamic loading spectra are used for the estimation of the fatigue life, they shall be specially considered by the Society.

4.6.6

- a) Where the size of the secondary barrier is reduced, as is provided for in [2.2.3], fracture mechanics analyses of fatigue crack growth shall be carried out to determine:
 - crack propagation paths in the structure
 - crack growth rate
 - the time required for a crack to propagate to cause a leakage from the tank
 - the size and shape of through thickness cracks; and
 - the time required for detectable cracks to reach a critical state.

The fracture mechanics are, in general, based on crack growth data taken as a mean value plus two standard deviations of the test data.
- b) In analysing crack propagation, the largest initial crack not detectable by the inspection method applied shall be assumed, taking into account the allowable non-destructive testing and visual inspection criterion, as applicable.
- c) Crack propagation analysis under the condition specified in [4.6.7]: the simplified load distribution and sequence over a period of 15 days may be used. Such distributions may be obtained as indicated in Fig 2. Load distribution and sequence for longer periods, such as in [4.6.8] and [4.6.9] shall be approved by the Society.
- d) The arrangements shall comply with [4.6.7] to [4.6.9], as applicable.

Figure 2 : Simplified load distribution

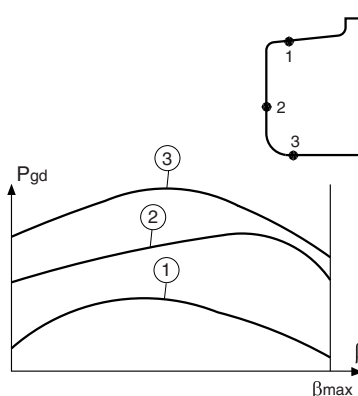

σ_0 is the most probable maximum stress over the life of the ship

Response cycle scale is logarithmic; the value of $2 \cdot 10^5$ is given as an example of estimate

4.6.7 For failures that can be reliably detected by means of leakage detection, C_w shall be less than or equal to 0,5. Predicted remaining failure development time, from the point of detection of leakage till reaching a critical state, shall not be less than 15 days, unless different requirements apply for ships engaged in particular voyages.

4.6.8 For failures that cannot be detected by leakage but that can be reliably detected at the time of in-service inspections, C_w shall be less than or equal to 0,5. Predicted remaining failure development time, from the largest crack not detectable by in-service inspection methods until reaching a critical state, shall not be less than three times the inspection interval.

4.6.9 In particular locations of the tank, where effective defect or crack development detection cannot be assured, the following, more stringent, fatigue acceptance criteria shall be applied as a minimum: C_w shall be less than or equal to 0,1. Predicted failure development time, from the assumed initial defect until reaching a critical state, shall not be less than three times the lifetime of the tank.

4.7 Accident design condition

4.7.1 The accident design condition is a design condition for accidental loads with extremely low probability of occurrence.

4.7.2 Analysis shall be based on the characteristic values as follows:

- permanent loads: expected values
- functional loads: specified values
- environmental loads: specified values
- accidental loads: specified values or expected values

4.7.3 Loads mentioned in [3.3.9] and [3.5] need not be combined with each other or with wave-induced loads.

5 Materials

5.1 General

5.1.1 The purpose of this article is to ensure that the cargo containment system, the thermal insulation, adjacent ship structure and other materials in the cargo containment system are constructed from materials of suitable properties for the conditions they will experience, both in normal service and in the event of failure of the primary barrier, where applicable.

5.2 Materials forming ship structure

5.2.1 To determine the grade of plate and sections used in the hull structure, a temperature calculation shall be performed for all tank types when the cargo temperature is below -10°C . The following assumptions shall be made in this calculation:

- a) The primary barrier of all tanks shall be assumed to be at the cargo temperature
- b) In addition to item a), where a complete or partial secondary barrier is required, it shall be assumed to be at the cargo temperature at atmospheric pressure for any one tank only
- c) For worldwide service, ambient temperatures shall be taken as 5°C for air and 0°C for seawater. Higher values may be accepted for ships operating in restricted areas and, conversely, lower values may be fixed by the Society for ships trading to areas where lower temperatures are expected during the winter months

Note 1: When the additional class notation **COLD (H t_{DH}, E t_{DE})** is assigned to the ship, two sets of temperature calculations are required, as defined in Pt F, Ch 8, Sec 4, [5.1.7]. The most stringent result is to be selected to determine the grade steel used in the hull structure.

- d) Still air and seawater conditions shall be assumed, i.e. no adjustment for forced convection
- e) Degradation of the thermal insulation properties over the life of the ship due to factors such as thermal and mechanical ageing, compaction, ship motions and tank vibrations, as defined in [5.4.6] and [5.4.7], shall be assumed
- f) The cooling effect of the rising boil-off vapour from the leaked cargo shall be taken into account, where applicable
- g) Credit for hull heating may be taken in accordance with [5.2.5], provided the heating arrangements are in compliance with [5.2.6]
- h) No credit shall be given for any means of heating, except as described in [5.2.5]; and
- i) For members connecting inner and outer hulls, the mean temperature may be taken for determining the steel grade.

The ambient temperatures used in the design, described in this paragraph, shall be shown on the International Certificate of Fitness for the Carriage of Liquefied Gases in Bulk.

5.2.2 The shell and deck plating of the ship and all stiffeners attached thereto shall be in accordance with recognized standards. If the calculated temperature of the material in the design condition is below -5°C due to the influence of the cargo temperature, the material shall be in accordance with Ch 9, Sec 6, Tab 6

5.2.3 The materials of all other hull structures for which the calculated temperature in the design condition is below 0°C, due to the influence of cargo temperature and that do not form the secondary barrier, shall also be in accordance with Ch 9, Sec 6, Tab 6. This includes hull structure supporting the cargo tanks, inner bottom plating, longitudinal bulkhead plating, transverse bulkhead plating, floors, webs, stringers and all attached stiffening members.

5.2.4 The hull material forming the secondary barrier shall be in accordance with Ch 9, Sec 6, Tab 3. Where the secondary barrier is formed by the deck or side shell plating, the material grade required by Ch 9, Sec 6, Tab 3 shall be carried into the adjacent deck or side shell plating, where applicable, to a suitable extent.

5.2.5 Means of heating structural materials may be used to ensure that the material temperature does not fall below the minimum allowed for the grade of material specified in Ch 9, Sec 6, Tab 6. In the calculations required in [5.2.1], credit for such heating may be taken in accordance with the following:

- a) For any transverse hull structure
- b) For longitudinal hull structure referred to in [5.2.2] and [5.2.3] where colder ambient temperatures are specified, provided the material remains suitable for the ambient temperature conditions of + 5°C for air and 0°C for seawater with no credit taken in the calculations for heating; and
- c) As an alternative to item b), for longitudinal bulkhead between cargo tanks, credit may be taken for heating, provided the material remain suitable for a minimum design temperature of – 30°C, or a temperature 30°C lower than that determined by [5.2.1] with the heating considered, whichever is less. In this case, the ship's longitudinal strength shall comply with requirements of Part B, Chapter 6 for both when those bulkhead(s) are considered effective and not.

5.2.6 The means of heating referred to in [5.2.5] shall comply with the following requirements:

- a) The heating system shall be arranged so that, in the event of failure in any part of the system, standby heating can be maintained equal to not less than 100% of the theoretical heat requirement
- b) The heating system shall be considered as an essential auxiliary. All electrical components of at least one of the systems provided in accordance with [5.2.5] a) shall be supplied from the emergency source of electrical power; and
- c) The design and construction of the heating system shall be included in the approval of the containment system by the Society.

5.2.7 Segregation of heating plant

Where a hull heating system complying with [5.2.5] is installed, this system is to be contained solely within the cargo area or the drain returns from the hull heating coils in the wing tanks, cofferdams and double bottom are to be led to a degassing tank. The degassing tank is to be located in the cargo area and the vent outlets are to be located in a safe position and fitted with a flame screen.

Note 1: In the case of an indirect heating system applied to the heating of cofferdams, degassing tank is not mandatory.

5.2.8 First loaded voyage

Attention is drawn to the requirements of Ch 9, Sec 1, [6.2.4] regarding the satisfactory operation of the heating plant, that is to be ascertained during the first full loading and the subsequent first unloading of ships carrying liquefied natural gases (LNG) in bulk.

5.3 Materials of primary and secondary barrier

5.3.1 Metallic materials used in the construction of primary and secondary barriers not forming the hull, shall be suitable for the design loads that they may be subjected to, and be in accordance with Ch 9, Sec 6, Tab 2, Ch 9, Sec 6, Tab 3 and Ch 9, Sec 6, Tab 4.

5.3.2 Materials, either non-metallic or metallic but not covered by Ch 9, Sec 6, Tab 2, Ch 9, Sec 6, Tab 3 and Ch 9, Sec 6, Tab 4 used in the primary and secondary barriers may be approved by the Society, considering the design loads that they may be subjected to, their properties and their intended use.

5.3.3 Where non-metallic materials, including composites, are used for, or incorporated in the primary or secondary barriers, they shall be tested for the following properties, as applicable, to ensure that they are adequate for the intended service:

- compatibility with the cargoes
- ageing
- mechanical properties
- thermal expansion and contraction
- abrasion
- cohesion
- resistance to vibrations
- resistance to fire and flame spread; and
- resistance to fatigue failure and crack propagation.

5.3.4 The above properties, where applicable, shall be tested for the range between the expected maximum temperature in service and +5°C below the minimum design temperature, but not lower than –196°C.

5.3.5 Where non-metallic materials, including composites, are used for the primary and secondary barriers, the joining processes shall also be tested as described above.

5.3.6 Guidance on the use of non-metallic materials in the construction of primary and secondary barriers is provided in Appendix 4 of the IGC Code.

5.3.7 Consideration may be given to the use of materials in the primary and secondary barrier, which are not resistant to fire and flame spread, provided they are protected by a suitable system such as a permanent inert gas environment, or are provided with a fire-retardant barrier.

5.4 Thermal insulation and other materials used in cargo containment systems

5.4.1 Load-bearing thermal insulation and other materials used in cargo containment systems shall be suitable for the design loads.

5.4.2 Thermal insulation and other materials used in cargo containment systems shall have the following properties, as applicable, to ensure that they are adequate for the intended service:

- compatibility with the cargoes
- solubility in the cargo
- absorption of the cargo
- shrinkage
- ageing
- closed cell content
- density
- mechanical properties, to the extent that they are subjected to cargo and other loading effects, thermal expansion and contraction
- abrasion
- cohesion
- thermal conductivity
- resistance to vibrations
- resistance to fire and flame spread; and
- resistance to fatigue failure and crack propagation.

5.4.3 The above properties, where applicable, shall be tested for the range between the expected maximum temperature in service and 5°C below the minimum design temperature, but not lower than –196°C.

5.4.4 Due to location or environmental conditions, thermal insulation materials shall have suitable properties of resistance to fire and flame spread and shall be adequately protected against penetration of water vapour and mechanical damage. Where the thermal insulation is located on or above the exposed deck, and in way of tank cover penetrations, it shall have suitable fire resistance properties in accordance with recognized standards or be covered with a material having low flame-spread characteristics and forming an efficient approved vapour seal.

5.4.5 Thermal insulation that does not meet recognized standards for fire resistance may be used in hold spaces that are not kept permanently inerted, provided its surfaces are covered with material with low flame-spread characteristics and that forms an efficient approved vapour seal.

5.4.6 Testing for thermal conductivity of thermal insulation shall be carried out on suitably aged samples.

5.4.7 Where powder or granulated thermal insulation is used, measures shall be taken to reduce compaction in service and to maintain the required thermal conductivity and also prevent any undue increase of pressure on the cargo containment system.

5.4.8 The materials for insulation are to be approved by the Society.

The approval of bonding materials, sealing materials, lining constituting a vapour barrier or mechanical protection is to be considered by the Society on a case-by-case basis. In any event, these materials are to be chemically compatible with the insulation material.

A particular attention is to be paid to the continuity of the insulation in way of tank supports.

5.4.9 Before applying the insulation, the surfaces of the tank structures or of the hull are to be carefully cleaned.

5.4.10 Where applicable, the insulation system is to be suitable to be visually examined at least on one side.

5.4.11 When the insulation is sprayed or foamed, the minimum steel temperature at the time of application is to be not less than the temperature given in the specification of the insulation.

6 Construction processes

6.1 General

6.1.1 *The purpose of this article is to define suitable construction processes and test procedures in order to ensure, as far as reasonably practical, that the cargo containment system will perform satisfactorily in service in accordance with the assumptions made at the stage design.*

6.2 Weld joint design

6.2.1 *All welded joints of the shells of independent tanks shall be of the in-plane butt weld full penetration type. For dome-to-shell connections only, tee welds of the full penetration type may be used depending on the results of the tests carried out at the approval of the welding procedure. Except for small penetrations on domes, nozzle welds shall also be designed with full penetration.*

The applicability of the expression “For dome-to-shell connections only” is clarified as follows:

- Welded corners (i.e. corners made of weld metal) are not to be used in the main tank shell construction, i.e. corners between shell side (sloped plane surfaces parallel to hopper or top side inclusive if any) and bottom or top of the tank, and between tank end transverse bulkheads and bottom, top or shell sides (sloped plane surfaces inclusive if any) of the tank. Instead, tank corners which are constructed using bent plating aligned with the tank surfaces and connected with in-plane welds are to be used.
- Tee welds can be accepted for other localised constructions of the shell such as suction well, sump, dome, etc. where tee welds of full penetration type are also to be used.

Note 1: This requirement is applicable to independent tanks of type A or type B, primarily constructed of plane surfaces. This includes the tank corners which are constructed using bent plating which is aligned with the tank surfaces and connected with in-plane welds.

6.2.2 *Welding joint details for type C independent tanks, and for the liquid-tight primary barriers Design for gluing of type B independent tanks primarily constructed of curved surfaces, shall be as follows:*

- *all longitudinal and circumferential joints shall be of butt welded, full penetration, double vee or single vee type. Full penetration butt welds shall be obtained by double welding or by the use of backing rings. If used, backing rings shall be removed except from very small process pressure vessels. Other edge preparations may be permitted, depending on the results of the tests carried out at the approval of the welding procedure; and*
- *the bevel preparation of the joints between the tank body and domes and between domes and relevant fittings shall be designed according to a standard acceptable to the Society. All welds connecting nozzles, domes or other penetrations of the vessel and all welds connecting flanges to the vessel or nozzles shall be full penetration welds.*

This requirement is applicable to type C independent tanks including bi-lobe tanks, primarily constructed of curved surfaces fitted with a centreline bulkhead. The applicability of the expression “Other edge preparations” is clarified as follows:

- Cruciform full penetration welded joints in a bi-lobe tank with centreline bulkhead can be accepted for the tank structure construction at tank centreline welds with bevel preparation subject to the approval of the Society, based on the results of the tests carried out at the approval of the welding procedure.

6.2.3 *Where applicable, all the construction processes and testing, except that specified in [6.4], shall be done in accordance with the applicable provisions of Ch 9, Sec 6.*

6.2.4 The following provisions apply to independent tanks:

- tracing, cutting and shaping are to be carried out so as to prevent, at the surface of the pieces, the production of defects detrimental to their use. In particular, marking the plates by punching and starting welding arcs outside the welding zone are to be avoided.
- before welding, the edges to be welded are to be carefully examined, with possible use of non-destructive examination, in particular when chamfers are carried out.
- in all cases, the working units are to be efficiently protected against bad weather.
- the execution of provisional welds, where any, is to be subjected to the same requirements as the constructional welds. After elimination of the fillets, the area is to be carefully ground and inspected (the inspection is to include, if necessary, a penetrant fluid test).
- all welding consumables are subject to agreement. Welders are also to be agreed.

6.3 Design for gluing and other joining processes

6.3.1 *The design of the joint to be glued (or joined by some other process except welding) shall take account of the strength characteristics of the joining process.*

6.4 Testing

6.4.1 *All cargo tanks and process pressure vessels shall be subjected to hydrostatic or hydropneumatic pressure testing in accordance with [8] to [13], as applicable for the tank type.*

6.4.2 All tanks shall be subject to a tightness test which may be performed in combination with the pressure test referred to in [6.4.1].

6.4.3 Requirements with respect to inspection of secondary barriers shall be decided by the Society in each case, taking into account the accessibility of the barrier (see [2.4.3]).

6.4.4 For containment systems with glued secondary barriers:

- at the time of construction, a tightness test should be carried out in accordance with approved system designers' procedures and acceptance criteria before and after initial cool down. Low differential pressures tests are not considered an acceptable test.
- if the designer's threshold values are exceeded, an investigation is to be carried out and additional testing such as thermographic or acoustic emissions testing should be carried out.
- the values recorded should be used as reference for future assessment of secondary barrier tightness.

For containment systems with welded metallic secondary barriers, a tightness test after initial cool down is not required.

6.4.5 The Society may require that for ships fitted with novel type B independent tanks, or tanks designed according to [14.1] at least one prototype tank and its supporting structures shall be instrumented with strain gauges or other suitable equipment to confirm stress levels. Similar instrumentation may be required for type C independent tanks, depending on their configuration and on the arrangement of their supports and attachments.

6.4.6 The overall performance of the cargo containment system shall be verified for compliance with the design parameters during the first full loading and discharging of the cargo, in accordance with the survey procedure and requirements in IGC Code, 1.6, and the requirements of the Society. Records of the performance of the components and equipment essential to verify the design parameters, shall be maintained and be available to the Society.

6.4.7 Heating arrangements, if fitted in accordance with [5.2.5] and [5.2.6], shall be tested for required heat output and heat distribution.

6.4.8 The cargo containment system shall be inspected for cold spots during, or immediately following, the first loaded voyage. Inspection of the integrity of thermal insulation surfaces that cannot be visually checked shall be carried out in accordance with recognized standards.

6.4.9 Tests are to be performed at the minimum service temperature or at a temperature very close to it.

6.4.10 The reliquefaction and inert gas production systems, if any, and the installation, if any, for use of gas as fuel for boilers and internal combustion engines are also to be tested to the satisfaction of the Surveyor.

6.4.11

- all operating data and temperatures read during the first voyage of the loaded ship are to be sent to the Society.
- attention is drawn to the requirements of Ch 9, Sec 1, [6.2.4] regarding the cold spots examination that is to be carried out on ships carrying liquefied natural gases (LNG) in bulk during the first loaded voyage.

6.4.12 All data and temperatures read during subsequent voyages are to be kept at the disposal of the Society for a suitable period of time.

7 Supports

7.1 Supporting arrangement

7.1.1 The cargo tanks shall be supported by the hull in a manner that prevents bodily movement of the tank under the static and dynamic loads defined in [3.2] to [3.5], where applicable, while allowing contraction and expansion of the tank under temperature variations and hull deflections without undue stressing of the tank and the hull.

7.1.2 Supports and supporting arrangements shall withstand the loads defined in [3.3.9] and [3.5], but these loads need not be combined with each other or with wave-induced loads

7.1.3 The reaction forces in way of tank supports are to be transmitted as directly as possible to the hull primary supporting members, minimising stress concentrations.

Where the reaction forces are not in the plane of primary members, web plates and brackets are to be provided in order to transmit these loads by means of shear stresses.

7.1.4 Special attention is to be paid to continuity of structure between circular tank supports and the primary supporting members of the ship.

7.1.5 Openings in tank supports and hull structures in way of tank supports are to be minimized and local strengthening may be necessary.

7.1.6 Insulating materials for tank supports are to be type approved by the Society.

Note 1: In addition to the justification of mechanical properties, the water absorption of the material should not be more than 6% when determined in accordance with DIN 53 495.

7.2 Calculation of reaction forces in way of tank supports

7.2.1 The reaction forces in way of tank supports are to be obtained from the structural analysis of the tank or stiffening rings in way of tank supports, considering the loads specified in [3.2] to [3.5].

The final distribution of the reaction forces at the supports is not to show any tensile forces.

7.3 Checking criteria

7.3.1 The requirements specified in [7.4] and [7.5] are to be checked regarding the following criteria:

a) For supports analysed through beam model, it is to be checked that the combined stress σ_C , in N/mm², is in compliance with the following formula: $\sigma_C \leq \sigma_{ALL}$

where:

σ_{ALL} : Allowable stress, in N/mm², defined in Tab 2 for each acceptance criteria.

b) For supports analysed through finite element model, the yield criteria, defined in Pt B, Ch 8, App 1, [5.2.3] for standard mesh size or in Pt B, Ch 8, App 2, [4.1.3] for fine mesh models, is to be checked.

The maximum permissible stresses are based on the mesh size of 50 x 50 mm. Where a smaller mesh size is used, an area weighted Von Mises stress calculated over an area equal to the specified mesh size may be used to compare with the permissible stresses.

Table 2 : Beam model: Allowable stresses σ_{ALL} , in N/mm² in all types of supports

Acceptance criteria	AC-1	AC-2	AC-3 (1)
σ_{ALL} , in N/mm ²	The lower of: <ul style="list-style-type: none"> • 0,9 R_m / 2,66 • 0,9 R_{eH} / 1,33 	The lower of: <ul style="list-style-type: none"> • R_m / 2,66 • R_{eH} / 1,33 	0,85 Ry
(1) Flooding, static heel 30° and collision conditions are to be checked considering AC-3 criteria			

7.4 Supports of type A and type B independent tanks

7.4.1 For parts, such as supporting structures, not otherwise covered by the requirements of the Code, stresses shall be determined by direct calculations, taking into account the loads referred to in [3.2] to [3.5] as far as applicable, and the ship deflection in way of supporting structures.

7.4.2 The tanks with supports shall be designed for the accidental loads specified in [3.5]. These loads need not be combined with each other or with environmental loads.

7.4.3 Moreover the tanks with supports are also to be designed for a static angle of heel of 30°.

7.4.4 Vertical supports

The structure of the tank and of the ship is to be reinforced in way of the vertical supports so as to withstand the reactions and the corresponding moments.

7.4.5 Antirolling supports

Antirolling supports are to be checked under transverse and vertical accelerations, as defined in [7.2.1] for the inclined ship conditions, and applied on the maximum weight of the full tank.

Antirolling supports are also to be checked for a static angle of heel of 30°.

7.4.6 Antipitching supports

Antipitching supports are to be checked under longitudinal accelerations and vertical accelerations, as defined in [7.2.1] for the upright conditions, and applied on the maximum weight of the full tank.

Antipitching supports are also to be checked for a static angle of heel of 30°.

7.4.7 Anticollision supports

Anticollision supports are to be provided to withstand a collision force acting on the tank corresponding to one half the weight of the tank and cargo in the forward direction and one quarter the weight of the tank and cargo in the aft direction.

Antipitching supports may be combined with anticollision supports.

7.4.8 Antiflotation supports

- a) *Anti-flotation arrangements shall be provided for independent tanks and capable of withstanding the loads defined in [3.5.3] without plastic deformation likely to endanger the hull structure.*
- b) Adequate clearance between the tanks and the hull structures is to be provided in all operating conditions.

7.4.9 Antiflotation supports are to be provided and are to be suitable to withstand an upward force caused by an empty tank in a hold space flooded to the scantling draught T_{sc} .

7.5 Supports of type C independent tanks

7.5.1 *The tanks with supports shall be designed for the accidental loads specified in [3.5]. These loads need not be combined with each other or with environmental loads.*

7.5.2 Moreover the tanks with supports are also to be designed for a static angle of heel of 30°.

7.5.3 The net scantlings of plating, ordinary stiffeners and primary supporting members of tank supports and hull structures in way of the supports are to be not less than those obtained by applying the criteria in Part B, Chapter 7.

The hull girder loads and the lateral pressure to be considered in the formulae above are to be obtained from the formulae in Part B, Chapter 5.

7.5.4 In addition to [7.5.3], the anticollision supports and antiflotation supports are to be checked according to [7.4.7] to [7.4.8].

8 Type A independent tanks

8.1 Design basis

8.1.1 *Type A independent tanks are tanks primarily designed using classical ship-structural analysis procedures in accordance with recognized standards. Where such tanks are primarily constructed of plane surfaces, the design vapour pressure P_o shall be less than 0.07 MPa.*

8.1.2 *If the cargo temperature at atmospheric pressure is below -10°C, a complete secondary barrier shall be provided as required in [2.3]. The secondary barrier shall be designed in accordance with [2.4].*

8.2 Structural analyses

8.2.1 *A structural analysis shall be performed taking into account the internal pressure as indicated in [3.3.2], and the interaction loads with the supporting and keying system as well as a reasonable part of the ship's hull.*

8.3 Ultimate design condition

8.3.1 *For tanks primarily constructed of plane surfaces, the nominal membrane stresses for primary and secondary members (stiffeners, web frames, stringers, girders), when calculated by classical analysis procedures, shall not exceed the lower of $R_m / 2,66$ or $R_{eH} / 1,33$ for nickel steels, carbon-manganese steels, austenitic steels and aluminium alloys, where R_m and R_{eH} are defined in [4.5], item c). However, if detailed calculations are carried out for the primary members, the equivalent stress σ_e , as defined in [4.5], item d), may be increased over that indicated above to a stress acceptable to the Society. Calculations shall take into account the effects of bending, shear, axial and torsional deformation as well as the hull/cargo tank interaction forces due to the deflection of the double bottom and cargo tank bottoms.*

8.3.2 *Tank boundary scantlings shall meet at least the requirements of the Society for deep tanks taking into account the internal pressure as indicated in [3.3.2] and any corrosion allowance required by [2.1.5].*

8.3.3 Plating

- a) The net thickness of plating of type A independent tanks, in mm, is to comply with the slenderness requirements of NR615 Buckling Assessment of plated structures.
- b) The net thickness of plating subject to lateral pressure, in mm, is to be checked according to Pt B, Ch 7, Sec 4, [1.1.1], considering:

$$P = p_{IGC}$$

where:

p_{IGC} : Internal lateral pressure, in kN/m², in the tank, as defined in [3.3.2] item e)

- c) The net thickness of plating subject to testing pressure, in mm, is to be checked according to Pt B, Ch 7, Sec 4, [1.1.1], considering:

$$P = p_{ST}$$

where:

p_{ST} : Testing pressure, in kN/m², obtained according to [8.5].

- d) The net thickness of plating subject to sloshing pressure is to be checked using the formula given in Pt B, Ch 7, Sec 4, [4].

8.3.4 Ordinary stiffeners

- a) The net thickness of web and face plate of ordinary stiffeners, in mm, is to comply with the slenderness requirements of NR615 Buckling Assessment of plated structures.
- b) The net section modulus Z, in cm³, and the net web thickness t_w , in mm, of ordinary stiffeners subjected to lateral pressure are to be checked according to Pt B, Ch 7, Sec 5, [1.1] considering:

$$P = p_{IGC}$$

$$C_s = C_t = \min \left[0,75 ; 0,37 \left(\frac{R_m}{R_{eH}} \right) \right]$$

where:

p_{IGC} : Internal lateral pressure, in kN/m², as defined in [3.3.2] item e)

- c) The net section modulus Z, in cm³, and the net web thickness t_w , in mm, of ordinary stiffeners subjected to testing pressure are to be checked according to Pt B, Ch 7, Sec 5, [1.1] considering:

$$P = p_{ST}$$

where:

p_{ST} : Testing pressure, in kN/m², obtained according to [8.5].

- d) The net section modulus of ordinary stiffeners subject to sloshing pressure, including longitudinals, are to be checked using the formulae given in Pt B, Ch 7, Sec 5, [1.3].

8.3.5 Primary supporting members

- a) The net thickness of web plating and flange of primary supporting members, in mm, is to comply with the slenderness requirements detailed in Section 2 of NR615 Buckling Assessment of plated structures.
- b) The scantlings of primary supporting members are to be not less than those obtained considering the lateral pressure P_{IGC} defined in [3.3.2], item e) and checking criteria specified in d).

The tank is here considered independently from the global structure of the ship, simply supported on his supports. Therefore only internal pressures are taken into account and hull girder loads are neglected.

- c) The scantlings of primary supporting members are to be not less than those obtained considering the hull girder loads and lateral pressures calculated according to Part B, Chapter 5 and checking criteria specified in d).

When calculating the internal pressure, the tank dome part to be considered in the accepted total tank volume is to be calculated according to Ch 9, App 1, [1.1.2].

- d) Checking criteria:

- for primary supporting members analysed through beam model, it is to be checked that the combined stress, in N/mm², is in compliance with the following formula:

$$\sigma_C \leq \sigma_{ALL}$$

where:

σ_{ALL} : Allowable stress, in N/mm², defined in Tab 3.

- for primary supporting members analysed through finite element model, the yield criteria defined in Pt B, Ch 8, App 1, [5.2.3] and Pt B, Ch 8, App 2, [4.1.3] as relevant, is to be checked considering the permissible yield utilisation factor λ_{yperm} defined in Tab 3.

Table 3 : Type A primary supporting members - Permissible coefficients

Acceptance criteria	Beam model σ_{ALL} , in N/mm ²	λ_{yperm} for finite element analysis
AC-2	The lower of: • $R_m / 2,66$ • $R_{eH} / 1,33$	Standard mesh • $\lambda_{yperm} = 0,9$
		Fine mesh (1) • $\lambda_{yperm} = 1,53 f_f$ for elements not adjacent to welding • $\lambda_{yperm} = 1,35 f_f$ for elements adjacent to welding
(1) The fatigue factor f_f is to be taken as: • $f_f = 1,0$ in general, including the free edge of base material • $f_f = 1,2$ for details assessed by very fine mesh analysis complying with the fatigue assessment criteria given in Ch 10, Sec 1		

8.3.6 Buckling

The scantlings of cargo tank structure of type A independent tank are to be not less than those obtained in compliance with Pt B, Ch 9, Sec 1 considering an allowable buckling utilisation factor η_{ALL} equal to 0,8 for AC- 1 and 0,9 for AC-2 criteria.

8.4 Accident design conditions

8.4.1 The tanks and the tank supports shall be designed for the accidental loads and design conditions specified in [2.1.4], item c) and [3.5], as relevant.

8.4.2 When subjected to the accidental loads specified in [3.5] and [3.3.9], the stress shall comply with the acceptance criteria specified in [8.3], modified as appropriate, taking into account their lower probability of occurrence.

8.4.3 Collision condition

For collision loads, the lateral pressure to be considered is to be calculated according to [3.5.2].

The verification is to be carried out for structural members of transverse bulkhead up to the first adjacent web frame, as shown in Fig 3.

Plating, ordinary stiffeners and primary structural members are to be checked using the formula given in Part B, Chapter 7 and Pt B, Ch 8, App 1, [5.2.3] and Pt B, Ch 8, App 2, [4.1.3] as relevant, taking into account permissible coefficients specified in Tab 4.

Buckling check is not required for collision condition.

Figure 3 : Extent of structural assessment for collision condition

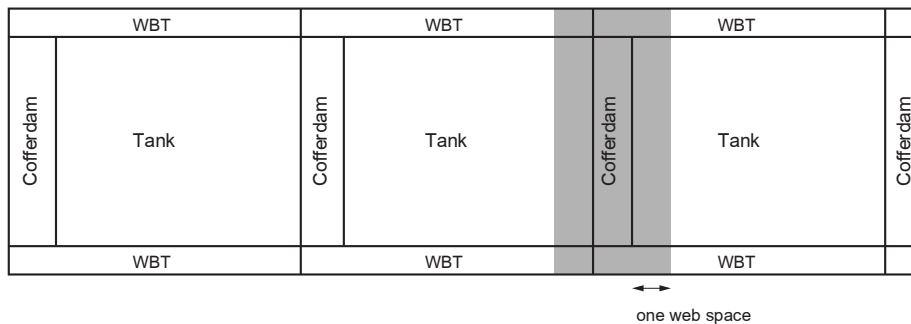

8.4.4 Heel Condition

Plating, ordinary stiffeners and primary structural members are to be checked using the formula given in Part B, Chapter 7 and Pt B, Ch 8, App 1, [5.2.3] and Pt B, Ch 8, App 2, [4.1.3] as relevant, taking into account permissible coefficients specified in Tab 4.

Buckling check is not required for heel condition.

Table 4 : Permissible coefficients for collision and 30° heel conditions

Plating	Ordinary stiffeners	Primary supporting members	
		Beam model	λ_{yperm} for finite element analysis
C_a	C_{sr}, C_{tr}, C_{comb}	C_{sr}, C_{tr}, C_{comb}	Standard mesh • $\lambda_{yperm} = 0,9$
1	1	0,85	Fine mesh (1) • $\lambda_{yperm} = 1,53 f_i$ for elements not adjacent to welding • $\lambda_{yperm} = 1,35 f_i$ for elements adjacent to welding
(1) The fatigue factor f_i is to be taken as: <ul style="list-style-type: none"> • $f_i = 1,0$ in general, including the free edge of base material • $f_i = 1,2$ for details assessed by very fine mesh analysis complying with the fatigue assessment criteria given in Ch 10, Sec 1 			

8.5 Testing

8.5.1 Testing

All type A independent tanks shall be subjected to a hydrostatic or hydropneumatic test. This test shall be performed such that the stresses approximate, as far as practicable, the design stresses, and that the pressure at the top of the tank corresponds at least to the MARVS. When a hydropneumatic test is performed, the conditions shall simulate, as far as practicable, the design loading of the tank and of its support structure, including dynamic components, while avoiding stress levels that could cause permanent deformation.

8.5.2 The conditions in which testing is performed are to simulate as far as possible the actual loading on the tank and its supports.

8.5.3 When testing takes place after installation of the cargo tank, provision is to be made prior to the launching of the ship in order to avoid excessive stresses in the ship structures.

9 Type B independent tanks

9.1 Design basis

9.1.1 Type B independent tanks are tanks designed using model tests, refined analytical tools and analysis methods to determine stress levels, fatigue life and crack propagation characteristics. Where such tanks are primarily constructed of plane surfaces (prismatic tanks), the design vapour pressure P_o shall be less than 0,07 MPa.

9.1.2 If the cargo temperature at atmospheric pressure is below -10°C , a partial secondary barrier with a small leak protection system shall be provided as required in [2.3]. The small leak protection system shall be designed according to [2.5].

9.2 Structural analyses

9.2.1 The effects of all dynamic and static loads shall be used to determine the suitability of the structure with respect to:

- plastic deformation
- buckling
- fatigue failure; and
- crack propagation.

Finite element analysis or similar methods and fracture mechanics analysis, or an equivalent approach, shall be carried out.

9.2.2 A three-dimensional analysis shall be carried out to evaluate the stress levels, including interaction with the ship's hull. The model for this analysis shall include the cargo tank with its supporting and keying system, as well as a reasonable part of the hull.

9.2.3 Analysis criteria

The analysis of the primary supporting members of the tank subjected to lateral pressure based on a three dimensional model is to be carried out according to the following requirements:

- the structural modeling is to comply with the requirements in Pt B, Ch 8, App 1, [2.4]
- the stress calculation is to comply with the requirements in Pt B, Ch 8, App 1, [5.2.1]
- the model extension is to comply with [9.2.4]
- the wave hull girder loads and the wave pressures to be applied on the model are to comply with [9.2.5]
- the inertial loads to be applied on the model are to comply with [3.3.2].

9.2.4 Model extension

The longitudinal extension of the structural model is to comply with Pt B, Ch 8, App 1, [2.2.1]. In any case, the structural model is to include the hull and the tank with its supporting and keying system.

9.2.5 Wave hull girder loads and wave pressures

A complete analysis of the particular ship accelerations and motions in irregular waves, and of the response of the ship and its cargo tanks to these forces and motions shall be performed, unless the data is available from similar ships.

Wave hull girder loads and wave pressures are to be obtained as the most probable the ship may experience during its operating life, for a probability level of 10^{-8} .

Calculation are to be submitted to the Society for approval, unless these data are available from similar ships.

9.3 Ultimate design condition

9.3.1 Plating and ordinary stiffeners

The thickness of the skin plate and the size of the stiffener shall not be less than those required for type A independent tanks.

Scantlings of plating and ordinary stiffeners are to be calculated according to [8.3].

9.3.2 Primary supporting members

a) Type B independent tanks primarily constructed of bodies of revolution

1) The equivalent stresses of primary supporting members of type B independent tanks primarily constructed of bodies of revolution are to comply with the following formula:

$$\sigma_E \leq \sigma_{ALL}$$

where:

σ_E : Equivalent stress, in N/mm^2 , to be obtained from the formula in [4.5.1] item d) for each of the following stress categories, defined in:

- primary general membrane stress
- primary local membrane stress
- primary bending stress
- secondary stress

σ_{ALL} : Allowable stress, defined in 2) for each of the stress categories above.

2) For type B independent tanks, primarily constructed of bodies of revolution, the allowable stresses shall not exceed:

$$\begin{aligned} \sigma_m &\leq f \\ \sigma_L &\leq 1,5 f \\ \sigma_b &\leq 1,5 F \\ \sigma_L + \sigma_b &\leq 1,5 F \\ \sigma_m + \sigma_b &\leq 1,5 F \\ \sigma_m + \sigma_b + \sigma_g &\leq 3,0 F \\ \sigma_L + \sigma_b + \sigma_g &\leq 3,0 F \end{aligned}$$

where:

- σ_m : Equivalent primary general membrane stress
- σ_L : Equivalent primary local membrane stress
- σ_b : Equivalent primary bending stress
- σ_g : Equivalent secondary stress
- f : The lesser of (R_m / A) or (R_e / B) ; and
- F : The lesser of (R_m / C) or (R_e / D)

with R_m and R_e as defined in [4.5.1], item c). With regard to the stresses σ_m , σ_L , σ_b and σ_g , the definition of stress categories in [4.3] are referred. The values A and B (and C and D) shall be shown on the International Certificate of Fitness for the Carriage of Liquefied Gases in Bulk and shall have at least minimum values as per Tab 5.

The above figures may be altered, taking into account the design condition considered in acceptance with the Society.

b) Type B independent tanks, primarily constructed of plane surfaces

1) The equivalent stresses of primary supporting members of type B independent tanks primarily constructed of plane surfaces are to comply with the following formula:

$$\sigma_E \leq \sigma_{ALL}$$

where:

- σ_E : Equivalent stress, in N/mm², to be obtained from the formulae in Pt B, Ch 8, App 1, [5.2.1], as a result of direct calculations to be carried out in accordance with [9.2.3]
- σ_{ALL} : Allowable stress, in N/mm², defined in item 2).

2) For type B independent tanks, primarily constructed of plane surfaces, the allowable membrane equivalent stresses applied for finite element analysis shall not exceed:

- for nickel steels and carbon-manganese steels, the lesser of $R_m / 2$ or $R_e / 1,2$;
- for austenitic steels, the lesser of $R_m / 2,5$ or $R_e / 1,2$; and
- for aluminium alloys, the lesser of $R_m / 2.5$ or $R_e / 1.2$.

The above figures may be amended, taking into account the locality of the stress, stress analysis methods and design condition considered in acceptance with the Society.

Table 5 : Minimum values of material coefficients

	Nickel steels and carbon manganese steels	Austenitic steels	Aluminium alloys
A	3	3,5	4
B	2	1,6	1,5
C	3	3	3
D	1,5	1,5	1,5

9.3.3 Buckling

a) Buckling strength analyses of cargo tanks subject to external pressure and other loads causing compressive stresses shall be carried out in accordance with recognized standards. The method shall adequately account for the difference in theoretical and actual buckling stress as a result of plate edge misalignment, lack of straightness or flatness, ovality and deviation from true circular form over a specified arc or chord length, as applicable.

b) The scantlings of plating and ordinary stiffeners of type B independent tanks are to be not less than those obtained from the applicable formulae in Pt B, Ch 9, Sec 1.

c) A local buckling check is to be carried out according to Pt B, Ch 9, Sec 1 for plate panels which constitute primary supporting members.

In performing this check, the stresses in the plate panels are to be obtained from direct calculations to be carried out in accordance with [9.2.3].

9.4 Fatigue design condition

9.4.1 Fatigue and crack propagation assessment shall be performed in accordance with [4.6]. The acceptance criteria shall comply with [4.6.7], [4.6.8], [4.6.9] depending on the detectability of the defect.

9.4.2 Fatigue analysis shall consider construction tolerances.

9.4.3 Where deemed necessary by the Society, model tests may be required to determine stress concentration factors and fatigue life of structural elements.

9.4.4 Fatigue analysis

a) General

The fatigue analysis is to be performed for areas where high wave induced stresses or large stress concentrations are expected, for welded joints and parent material. Such areas are to be defined by the Designer and agreed by the Society on a case-by-case basis.

b) Material properties

The material properties affecting fatigue of the items checked are to be documented. Where this documentation is not available, the Society may request to obtain these properties from experiments performed in accordance with recognised standards.

c) Wave loads

In upright ship and in inclined ship conditions the wave loads to be considered for the fatigue analysis of the tank include:

- maximum and minimum wave hull girder loads and wave pressures, to be obtained from a complete analysis of the ship motion and accelerations in irregular waves, to be submitted to the Society for approval, unless these data are available from similar ships. These loads are to be obtained as the most probable the ship may experience during its operating life, for a probability level of 10^{-8} .
- maximum and minimum inertial pressures, to be obtained from the formulae in [3.3.2] as a function of the arbitrary direction β .

d) Simplified stress distribution for fatigue analysis

The simplified long-term distribution of wave loads indicated in [4.6.6], item c) may be represented by means of 8 stress ranges, each characterised by an alternating stress $\pm \sigma_i$ and a number of cycles n_i (see Fig 4). The corresponding values of σ_i and n_i are to be obtained from the following formulae:

$$\sigma_i = \sigma_0 \left(1,0625 - \frac{i}{8} \right)$$

$$n_i = 0,9 \cdot 10^i$$

where:

σ_i : Stress ($i = 1, 2, \dots, 8$), in N/mm^2 (see Fig 4)

σ_0 : Most probable maximum stress over the life of the ship, in N/mm^2 , for a probability level of 10^{-8}

n_i : Number of cycles for each stress σ_i considered ($i = 1, 2, \dots, 8$).

Figure 4 : Simplified stress distribution for fatigue analysis

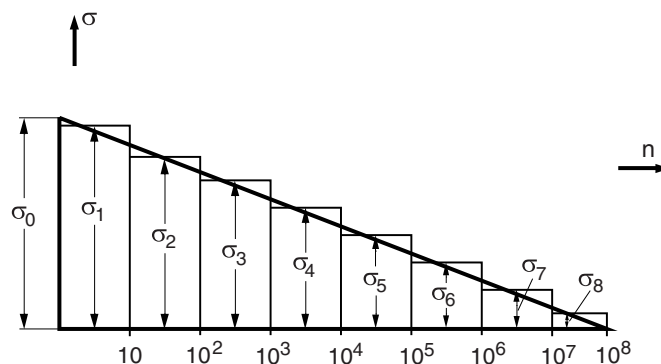

e) Conventional cumulative damage

For each structural detail for which the fatigue analysis is to be carried out, the conventional cumulative damage is to be calculated according to the following procedure:

- the long-term value of hot spot stress range $\Delta\sigma_{s,0}$ is to be obtained from the following formula:

$$\Delta\sigma_{s,0} = |\sigma_{s,MAX} - \sigma_{s,MIN}|$$

where:

$\sigma_{S,MAX}$, $\sigma_{S,MIN}$: Maximum and minimum hot spot stress to be obtained from a structural analysis carried out in accordance with Part B, Chapter 10 and NI611, where the wave loads are those defined in [9.4.4] item c).

- the long-term value of the notch stress range $\Delta\sigma_{N,0}$ is obtained from the formulae in Pt B, Ch 10, Sec 1 as a function of the hot spot stress range $\Delta\sigma_{S,0}$.
- the long-term distribution of notch stress ranges $\Delta\sigma_{N,i}$ is to be calculated. Each stress range $\Delta\sigma_{N,i}$ of the distribution, corresponding to n_i stress cycles, is obtained from the formulae in item d), where σ_0 is taken equal to $\Delta\sigma_{N,0}$.
- for each notch stress range $\Delta\sigma_{N,i}$ the number of stress cycles N_i which cause the fatigue failure is to be obtained by means of S-N curves corresponding to the as-rolled condition (see Fig 5). The criteria adopted for obtaining the S-N curves are to be documented. Where this documentation is not available, the Society may require the curves to be obtained from experiments performed in accordance with recognised standards.
- the conventional cumulative damage for the i notch stress ranges $\Delta\sigma_{N,i}$ is to be obtained from the formula in [4.6.2].

f) Check criteria

The conventional cumulative damage, to be calculated according to item e) is to be not greater than C_{Wv} , defined in [4.6.2].

Figure 5 : Fatigue check based on conventional cumulative damage method

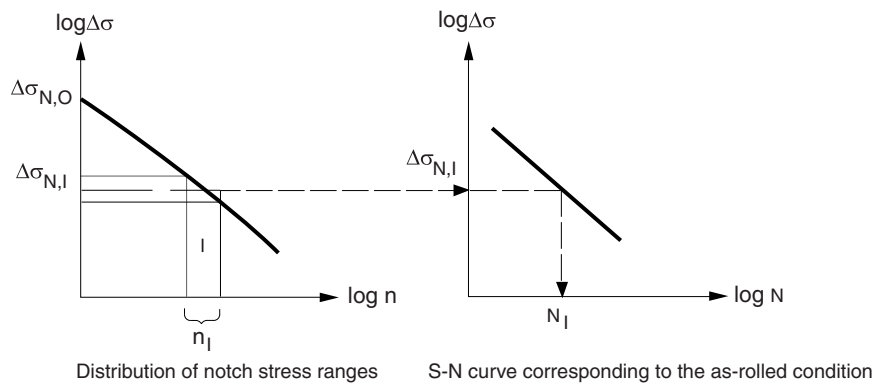

9.4.5 Crack propagation analysis

a) General

The crack propagation analysis is to be carried out for highly stressed areas. The latter are to be defined by the Designer and agreed by the Society on a case-by-case basis. Propagation rates in the parent material, weld metal and heat-affected zone are to be considered.

The following checks are to be carried out:

- crack propagation from an initial defect, in order to check that the defect will not grow and cause a brittle fracture before the defect is detected; this check is to be carried out according to item d)
- crack propagation from an initial through thickness defect, in order to check that the defect, resulting in a leakage, will not grow and cause a brittle fracture less than 15 days after its detection; this check is to be carried out according to item e).

b) Material properties

The material fracture mechanical properties used for the crack propagation analysis, i.e. the properties relating the crack propagation rate to the stress intensity range at the crack tip, are to be documented for the various thicknesses of parent material and weld metal alike. Where this documentation is not available, the Society may request to obtain these properties from experiments performed in accordance with recognised standards.

c) Simplified stress distribution for crack propagation analysis

The simplified wave load distribution indicated in [4.6.6] item c) may be represented over a period of 15 days by means of 5 stress ranges, each characterised by an alternating stress $\pm \sigma_i$ and number of cycles, n_i (see Fig 6). The corresponding values of σ_i and n_i are to be obtained from the following formulae:

$$\sigma_i = \sigma_0 \left(1, 1 - \frac{i}{5,3} \right)$$

$$n_i = 0,913 \cdot 10^i$$

where:

σ_i : Stress ($i = 1,06; 2,12; 3,18; 4,24; 5,30$), in N/mm² (see Fig 6)

σ_0 : Defined in [9.4.4], item d)

n_i : Number of cycles for each stress σ_i considered ($i = 1,06; 2,12; 3,18; 4,24; 5,30$).

Figure 6 : Simplified stress distribution for crack propagation analysis

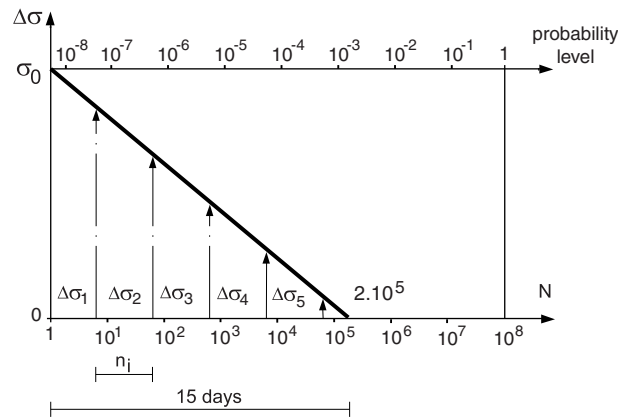

d) Crack propagation analysis from an initial defect

It is to be checked that an initial crack will not grow, under wave loading based on the stress distribution in [9.4.4] d), beyond the allowable crack size.

The initial size and shape of the crack is to be considered by the Society on a case-by-case basis, taking into account the structural detail and the inspection method.

The allowable crack size is to be considered by the Society on a case-by-case basis; in any event, it is to be taken less than that which may lead to a loss of effectiveness of the structural element considered.

e) Crack propagation analysis from an initial through thickness defect

It is to be checked that an initial through thickness crack will not grow, under dynamic loading based on the stress distribution in item c), beyond the allowable crack size.

The initial size of the through thickness crack is to be taken not less than that through which the minimum flow size that can be detected by the monitoring system (e.g. gas detectors) may pass.

The allowable crack size is to be considered by the Society on a case-by-case basis; in any event, it is to be taken far less than the critical crack length, defined in item f).

f) Critical crack length

The critical crack length is the crack length from which a brittle fracture may initiate and it is to be considered by the Society on a case-by-case basis. In any event, it is to be evaluated for the most probable maximum stress experienced by the structural element in the ship life, which is equal to the stress in the considered detail obtained from the structural analysis to be performed in accordance with [9.2.3].

9.5 Accident design condition

9.5.1 The tanks and the tank supports shall be designed for the accidental loads and design conditions specified in [2.1.4], item c) and [3.5], as applicable.

9.5.2 When subjected to the accidental loads specified in [3.5] and [3.3.9], the stress shall comply with the acceptance criteria specified in [9.3], modified as appropriate, taking into account their lower probability of occurrence.

9.5.3 Collision condition

The structure of the tank is to be checked for collision loads using pressure and criteria defined in [8.4.3].

9.5.4 Heel condition

The structure of the tank is to be checked for heel loads using pressure and criteria defined in [8.4.4].

9.6 Testing

9.6.1 Type B independent tanks shall be subjected to a hydrostatic or hydropneumatic test as follows:

- the test shall be performed as required in [8.5] for type A independent tanks; and
- in addition, the maximum primary membrane stress or maximum bending stress in primary members under test conditions shall not exceed 90% of the yield strength of the material (as fabricated) at the test temperature. To ensure that this condition is satisfied, when calculations indicate that this stress exceeds 75% of the yield strength, the prototype test shall be monitored by the use of strain gauges or other suitable equipment.

9.6.2 The conditions in which testing is performed are to simulate as far as possible the actual loading on the tank and its supports.

9.6.3 When testing takes place after installation of the cargo tank, provision is to be made prior to the launching of the ship in order to avoid excessive stresses in the ship structures.

9.7 Marking

9.7.1 Any marking of the pressure vessel shall be achieved by a method that does not cause unacceptable local stress raisers.

10 Type C independent tanks

10.1 Design basis

10.1.1 The design basis for type C independent tanks is based on pressure vessel criteria modified to include fracture mechanics and crack propagation criteria. The minimum design pressure defined in item [10.1.2] is intended to ensure that the dynamic stress is sufficiently low, so that an initial surface flaw will not propagate more than half the thickness of the shell during the lifetime of the tank.

10.1.2 The design vapour pressure, in MPa, shall not be less than:

$$P_o = 0.2 + AC(\rho_r)^{1.5}$$

where:

$$A = 0,00185 \left(\frac{\sigma_m}{\Delta\sigma_A} \right)^2$$

with:

σ_m : Design primary membrane stress

$\Delta\sigma_A$: Allowable dynamic membrane stress (double amplitude at probability level $Q = 10^{-8}$) and equal to:

- 55 N/mm² for ferritic-perlitic, martensitic and austenitic steel
- 25 N/mm² for aluminium alloy (5083-O)

C : A characteristic tank dimension to be taken as the greatest of the following:

- h
- 0,75 b
- 0,45 ℓ

with

h : Height of tank (dimension in ship's vertical direction), in m

b : Width of tank (dimension in ship's transverse direction), in m

ℓ : Length of tank (dimension in ship's longitudinal direction), in m

ρ_r : The relative density of the cargo ($\rho_r = 1$ for fresh water) at the design temperature.

When a specified design life of the tank is longer than 10^8 wave encounters, $\Delta\sigma_A$ shall be modified to give equivalent crack propagation corresponding to the design life.

10.1.3 The Society may allocate a tank complying with the criteria of type C tank minimum design pressure as in [10.1.2], to a type A or type B, dependent on the configuration of the tank and the arrangement of its supports and attachments.

10.2 Shell thickness

10.2.1 The shell thickness shall be as follows:

- a) For pressure vessels, the thickness calculated according to [10.2.4] shall be considered as a minimum thickness after forming, without any negative tolerance.
- b) For pressure vessels, the minimum thickness of shell and heads including corrosion allowance, after forming, shall not be less than 5 mm for carbon-manganese steels and nickel steels, 3 mm for austenitic steels or 7 mm for aluminium alloys.
- c) The welded joint efficiency factor to be used in the calculation according to [10.2.4] shall be 0,95 when the inspection and the non-destructive testing referred to in Ch 9, Sec 6, [5.6.7] are carried out. This figure may be increased up to 1 when account is taken of other considerations, such as the material used, type of joints, welding procedure and type of loading. For process pressure vessels, the Society may accept partial non-destructive examinations, but not less than those of Ch 9, Sec 6, [5.6.6], depending on such factors as the material used, the design temperature, the nil-ductility transition temperature of the material, as fabricated, and the type of joint and welding procedure, but in this case an efficiency factor of not more than 0,85 shall be adopted. For special materials, the above-mentioned factors shall be reduced, depending on the specified mechanical properties of the welded joint.

10.2.2 The design liquid pressure defined in [3.3.2] shall be taken into account in the internal pressure calculations.

10.2.3 The design external pressure P_e , in MPa, used for verifying the buckling of the pressure vessels, shall not be less than that given by:

$$P_e = P_1 + P_2 + P_3 + P_4$$

where:

- P_1 : Setting value of vacuum relief valves. For vessels not fitted with vacuum relief valves, P_1 shall be specially considered, but shall not, in general, be taken as less than 0,025 MPa
- P_2 : The set pressure of the pressure relief valves (PRVs) for completely closed spaces containing pressure vessels or parts of pressure vessels; elsewhere $P_2=0$
- P_3 : Compressive actions in or on the shell due to the weight and contraction of thermal insulation, weight of shell including corrosion allowance and other miscellaneous external pressure loads to which the pressure vessel may be subjected. These include, but are not limited to, weight of domes, weight of towers and piping, effect of product in the partially filled condition, accelerations and hull deflection. In addition, the local effect of external or internal pressures or both shall be taken into account; and
- P_4 : External pressure due to head of water for pressure vessels or part of pressure vessels on exposed decks; elsewhere $P_4 = 0$.

10.2.4 Scantlings based on internal pressure shall be calculated as follows: the thickness and form of pressure-containing parts of pressure vessels, under internal pressure, as defined in [3.3.2], including flanges, shall be determined. These calculations shall in all cases be based on accepted pressure vessel design theory. Openings in pressure-containing parts of pressure vessels shall be reinforced in accordance with recognized standards.

10.2.5 Stress analysis in respect of static and dynamic loads shall be performed as follows:

- pressure vessel scantlings shall be determined in accordance with [10.2.1] to [10.2.4] and [10.3].
- calculations of the loads and stresses in way of the supports and the shell attachment of the support shall be made. Loads referred to in [3.2] to [3.5] shall be used, as applicable. Stresses in way of the supporting structures shall be to a recognized standard acceptable to the Society. In special cases, a fatigue analysis may be required by the Society.
- if required by the Society, secondary stresses and thermal stresses shall be specially considered.

10.3 Ultimate design condition

10.3.1 The type C independent cargo tanks are to comply with the requirements of Pt C, Ch 1, Sec 3 related to class 1 pressure vessels. The allowable stresses are defined in [10.3.2].

10.3.2 Plastic deformation

For type C independent tanks, the allowable stresses shall not exceed:

$$\sigma_m \leq f$$

$$\sigma_l \leq 1,5 f$$

$$\sigma_b \leq 1,5 f$$

$$\sigma_l + \sigma_b \leq 1,5 f$$

$$\sigma_m + \sigma_b \leq 1,5 f$$

$$\sigma_m + \sigma_b + \sigma_g \leq 3,0 f$$

$$\sigma_l + \sigma_b + \sigma_g \leq 3,0 f$$

where:

- σ_m : Equivalent primary general membrane stress
- σ_l : Equivalent primary local membrane stress
- σ_b : Equivalent primary bending stress
- σ_g : Equivalent secondary stress
- f : The lesser of (R_m / A) or (R_e / B)

with R_m and R_e as defined in [4.5], item c). With regard to the stresses σ_m , σ_l , σ_b and σ_g , the definition of stress categories in [4.3] are referred. The values A and B shall be shown on the International Certificate of Fitness for the Carriage of Liquefied Gases in Bulk and shall have at least the minimum values as per Tab 6.

Table 6 : Minimum values of material coefficients

	Nickel steels and carbon manganese steels	Austenitic steels	Aluminium alloys
A	3	3,5	4
B	1,5	1,5	1,5

10.3.3 Buckling

Buckling criteria shall be as follows: the thickness and form of pressure vessels subject to external pressure and other loads causing compressive stresses shall be based on calculations using accepted pressure vessel buckling theory and shall adequately account for the difference in theoretical and actual buckling stress as a result of plate edge misalignment, ovality and deviation from true circular form over a specified arc or chord length.

10.3.4 Stiffening rings in way of tanks supports

a) Structural model:

The stiffening rings in way of supports of horizontal cylindrical tanks are to be modeled as circumferential beams constituted by web, flange, doubler plate, if any, and plating attached to the stiffening rings.

b) Width of attached plating:

On each side of the web, the width of the attached plating to be considered for the yielding and buckling checks of the stiffening rings, as in item e) and item f), respectively, is to be obtained, in mm, from the following formulae:

- $b = 0,78\sqrt{rt}$ for cylindrical shell,
- $b = 20 t_b$ for longitudinal bulkheads (in the case of lobe tanks)

where:

- r : Mean radius, in mm, of the cylindrical shell
- t : Shell thickness, in mm
- t_b : Bulkhead thickness, in mm.

A doubler plate, if any, may be considered as belonging to the attached plating.

c) Boundary conditions:

The boundary conditions of the stiffening ring are to be modeled as follows:

- circumferential forces applied on each side of the ring, whose resultant is equal to the shear force in the tank and calculated through the bi-dimensional shear flow theory
- reaction forces in way of tank supports, to be obtained according to [7.2].

d) Lateral pressure:

The lateral pressure to be considered for the check of the stiffening rings is to be obtained from [3.3.2].

e) Yielding check:

The equivalent stress in stiffening rings in way of supports is to comply with the following formula:

$$\sigma_E \leq \sigma_{ALL}$$

where:

σ_E : Equivalent stress in stiffening rings calculated for the load cases defined in [7.1.2] and to be obtained from the following formula:

$$\sigma_E = \sqrt{(\sigma_N + \sigma_B)^2 + 3\tau^2}$$

σ_N : Normal stress, in N/mm², in the circumferential direction of the stiffening ring

σ_B : Bending stress, in N/mm², in the circumferential direction of the stiffening ring

τ : Shear stress, in N/mm², in the stiffening ring

σ_{ALL} : Allowable stress, in N/mm², to be taken equal to the lesser of the following values:

- 0,57 R_m
- 0,85 R_{eH}

f) Buckling check:

The buckling strength of the stiffening rings is to be checked in compliance with the applicable formulae in Pt B, Ch 9, Sec 1.

10.4 Fatigue design condition

10.4.1 *For large type C independent tanks, where the cargo at atmospheric pressure is below –55°C, the Society may require additional verification to check their compliance with [10.1.1] regarding static and dynamic stress.*

10.5 Accident design condition

10.5.1 *The tanks and the tank supporting structures shall be designed for the accidental loads and design conditions specified in [2.1.4], item c) and [3.5], as applicable.*

10.5.2 *When subjected to the accidental loads specified in [3.5] and [3.3.9], the stress shall comply with the acceptance criteria specified in [10.3.1], modified as appropriate taking into account their lower probability of occurrence.*

10.5.3 Collision condition

The structure of the tank is to be checked for collision loads using pressure and criteria defined in [8.4.3].

10.5.4 Heel condition

The structure of the tank is to be checked for heel loads using pressure and criteria defined in [8.4.4].

10.6 Testing

10.6.1 Each pressure vessel shall be subjected to a hydrostatic test at a pressure measured at the top of the tanks, of not less than $1,5 P_o$. In no case during the pressure test shall the calculated primary membrane stress at any point exceed 90% of the yield stress of the material. To ensure that this condition is satisfied where calculations indicate that this stress will exceed 0,75 times the yield strength, the prototype test shall be monitored by the use of strain gauges or other suitable equipment in pressure vessels other than simple cylindrical and spherical pressure vessels.

10.6.2 The temperature of the water used for the test shall be at least 30°C above the nil-ductility transition temperature of the material, as fabricated.

10.6.3 The pressure shall be held for 2 h per 25 mm of thickness, but in no case less than 2 h.

10.6.4 Where necessary for cargo pressure vessels, a hydropneumatic test may be carried out under the conditions prescribed in [10.6.1] to [10.6.3].

10.6.5 Special consideration may be given to the testing of tanks in which higher allowable stresses are used, depending on service temperature. However, the requirements of [10.6.1] shall be fully complied with.

10.6.6 After completion and assembly, each pressure vessel and its related fittings shall be subjected to an adequate tightness test which may be performed in combination with the pressure testing referred to in [10.6.1].

10.6.7 Pneumatic testing of pressure vessels other than cargo tanks shall only be considered on an individual case basis. Such testing shall only be permitted for those vessels designed or supported such that they cannot be safely filled with water, or for those vessels that cannot be dried and are to be used in a service where traces of the testing medium cannot be tolerated.

10.6.8 The conditions in which testing is performed are to simulate as far as possible the actual loading on the tank and its supports.

10.6.9 When testing takes place after installation of the cargo tank, provision is to be made prior to the launching of the ship in order to avoid excessive stresses in the ship structures.

10.7 Marking

10.7.1 The required marking of the pressure vessel shall be achieved by a method that does not cause unacceptable local stress raisers.

11 Membrane tanks

11.1 Design Basis

11.1.1 Membrane tanks designed for products defined in Ch 9, Sec 19, except LNG, are to be in compliance with [2.4.2], as applicable.

11.1.2 If the cargo temperature at atmospheric pressure is below -10°C , a complete secondary barrier shall be provided as required in [2.3]. The secondary barrier shall be designed according to [2.4].

12 Integral tanks

12.1 Design basis

12.1.1 Integral tanks that form a structural part of the hull and are affected by the loads that stress the adjacent hull structure shall comply with the following:

- the design vapour pressure P_o , as defined in [1.2.2] shall not normally exceed 0,025 MPa. If the hull scantlings are increased accordingly, P_o may be increased to a higher value, but less than 0,07 MPa
- integral tanks may be used for products, provided the boiling point of the cargo is not below -10°C . A lower temperature may be accepted by the Society subject to special consideration, but in such cases a complete secondary barrier shall be provided; and
- products required by Ch 9, Sec 19 to be carried in type 1G ships shall not be carried in integral tanks.

12.2 Structural analysis

12.2.1 The structural analysis of integral tanks shall be in accordance with recognized standards.

12.2.2 The net scantlings of plating, ordinary stiffeners and primary supporting members of integral tanks are to be not less than those obtained from Part B, Chapter 7, where the hull girder loads and the internal pressure are to be calculated according to Part B, Chapter 5.

12.3 Ultimate design condition

12.3.1 *The tank boundary scantlings shall meet the requirements for deep tanks, taking into account the internal pressure as indicated in [3.3.2].*

12.3.2 *For integral tanks, allowable stresses shall normally be those given for hull structure in the requirements of the Society.*

12.4 Accident design condition

12.4.1 *The tanks and the tank supports shall be designed for the accidental loads specified in [2.1.4], item c) and [3.5], as relevant.*

12.4.2 *When subjected to the accidental loads specified in [3.5] and [3.3.9], the stress shall comply with the acceptance criteria specified in [12.3], modified as appropriate, taking into account their lower probability of occurrence.*

12.5 Testing

12.5.1 *All integral tanks shall be hydrostatically or hydropneumatically tested. The test shall be performed so that the stresses approximate, as far as practicable, to the design stresses and that the pressure at the top of the tank corresponds at least to the MARVS.*

12.5.2 The testing of integral tanks is to comply with the requirements in Pt B, Ch 13, Sec 6.

13 Semi-membrane tanks

13.1 Design basis

13.1.1 *Semi-membrane tanks are non-self-supporting tanks when in the loaded condition and consist of a layer, parts of which are supported through thermal insulation by the adjacent hull structure, whereas the rounded parts of this layer connecting the above-mentioned supported parts are designed also to accommodate the thermal and other expansion or contraction.*

13.1.2 *The design vapour pressure P_o shall not normally exceed 0,025 MPa. If the hull scantlings are increased accordingly, and consideration is given, where appropriate, to the strength of the supporting thermal insulation, P_o may be increased to a higher value, but less than 0,07 MPa.*

13.1.3 *For semi-membrane tanks the relevant requirements in this section for independent tanks or for membrane tanks shall be applied as appropriate.*

13.1.4 *In the case of semi-membrane tanks that comply in all respects with the requirements applicable to type B independent tanks, except for the manner of support, the Society may, after special consideration, accept a partial secondary barrier.*

14 Cargo containment systems of novel configuration

14.1 Limit state design for novel concepts

14.1.1 *Cargo containment systems that are of a novel configuration that cannot be designed using [8] to [13] shall be designed using this sub-article and Articles [2] and [3], and also Articles [4], [5] and [6] as applicable. Cargo containment system design according to this section shall be based on the principles of limit state design which is an approach to structural design that can be applied to established design solutions as well as novel designs. This more generic approach maintains a level of safety similar to that achieved for known containment systems as designed using [8] to [13].*

14.1.2 *The limit state design is a systematic approach where each structural element is evaluated with respect to possible failure modes related to the design conditions identified in [2.1.4]. A limit state can be defined as a condition beyond which the structure, or part of a structure, no longer satisfies the requirements.*

14.1.3 *For each failure mode, one or more limit states may be relevant. By consideration of all relevant limit states, the limit load for the structural element is found as the minimum limit load resulting from all the relevant limit states. The limit states are divided into the three following categories:*

- *Ultimate limit states (ULS), which correspond to the maximum load-carrying capacity or, in some cases, to the maximum applicable strain or deformation; under intact (undamaged) conditions.*
- *Fatigue limit states (FLS), which correspond to degradation due to the effect of time varying (cyclic) loading.*
- *Accident limit states (ALS), which concern the ability of the structure to resist accidental situations.*

14.1.4 *The procedure and relevant design parameters of the limit state design shall comply with the Standards for the Use of limit state methodologies in the design of cargo containment systems of novel configuration (LSD Standard), as set out in Appendix 5 of the IGC Code.*

14.1.5 The testing of semi-membrane tanks is to comply with the requirements in Pt B, Ch 13, Sec 6.

Section 5 Process Pressure Vessels and Liquid, Vapour and Pressure Piping Systems

1 General

1.1

1.1.1 *The requirements of this Section shall apply to products and process piping, including vapour piping, gas fuel piping and vent lines of safety valves or similar piping. Auxiliary piping systems not containing cargo are exempt from the general requirements of this Section.*

1.1.2 Cargo and process pipings have to comply with the applicable requirements of Pt C, Ch 1, Sec 10 for class I pressure piping, unless otherwise specified in IGC Code or in the present Article.

1.1.3 *The requirements for type C independent tanks provided in Ch 9, Sec 4 may also apply to process pressure vessels. If so required, the term "pressure vessels" as used in Ch 9, Sec 4, covers both type C independent tanks and process pressure vessels.*

1.1.4 *Process pressure vessels include surge tanks, heat exchangers and accumulators that store or treat liquid or vapour cargo.*

1.1.5 Process pressure vessels handling cargo are to be considered as class 1 pressure vessels, in accordance with Pt C, Ch 1, Sec 3, [1.4.1].

2 System requirements

2.1

2.1.1 The connections, if any, to the cargo tanks of relief valve discharges fitted on the liquid phase cargo piping are not to be fitted with shut-off valves, but are to be provided with non-return valves in the proximity of the tanks.

2.1.2 Overpressure relief valves on cargo pumps may be omitted in the case of centrifugal pumps having a maximum delivery head, the delivery valve being completely closed, not greater than that permitted for the piping.

2.1.3 *The cargo handling and cargo control systems shall be designed taking into account the following:*

- *prevention of an abnormal condition escalating to a release of liquid or vapour cargo*
- *the safe collection and disposal of cargo fluids released*
- *prevention of the formation of flammable mixtures*
- *prevention of ignition of flammable liquids or gases and vapours released, and*
- *limiting the exposure of personnel to fire and other hazards.*

2.2 Arrangements: General

2.2.1 *Any piping system that may contain cargo liquid or vapour shall:*

- *be segregated from other piping systems, except where interconnections are required for cargo-related operations such as purging, gas-freeing or inerting. The requirements of Ch 9, Sec 9, [1.4.5] shall be taken into account with regard to preventing back-flow of cargo. In such cases, precautions shall be taken to ensure that cargo or cargo vapour cannot enter other piping systems through the interconnections*
- *except as provided in Ch 9, Sec 16, not pass through any accommodation space, service space or control station or through a machinery space other than a cargo machinery space*
- *be connected to the cargo containment system directly from the weather decks except where pipes installed in a vertical trunkway or equivalent are used to traverse void spaces above a cargo containment system and except where pipes for drainage, venting or purging traverse cofferdams*
- *be located in the cargo area above the weather deck except for bow or stern loading and unloading arrangements in accordance with Ch 9, Sec 3, [1.8], emergency cargo jettisoning piping systems in accordance with [3.1], turret compartment systems in accordance with [3.3] and except in accordance with Ch 9, Sec 16, and*
- *be located inboard of the transverse tank location requirements of Ch 9, Sec 2, [4.1.1], except for athwartship shore connection piping not subject to internal pressure at sea or emergency cargo jettisoning piping systems.*

2.2.2 *Suitable means shall be provided to relieve the pressure and remove liquid cargo from loading and discharging crossover headers; likewise, any piping between the outermost manifold valves and loading arms or cargo hoses to the cargo tanks, or other suitable location, prior to disconnection.*

2.2.3 Piping systems carrying fluids for direct heating or cooling of cargo shall not be led outside the cargo area unless a suitable means is provided to prevent or detect the migration of cargo vapour outside the cargo area (see Ch 9, Sec 13, [6.1.2], item f)).

2.2.4 Relief valves discharging liquid cargo from the piping system shall discharge into the cargo tanks. Alternatively, they may discharge to the cargo vent mast, if means are provided to detect and dispose of any liquid cargo that may flow into the vent system. Where required to prevent overpressure in downstream piping, relief valves on cargo pumps shall discharge to the pump suction.

3 Arrangements for cargo piping outside the cargo area

3.1 Emergency cargo jettisoning

3.1.1 If fitted, an emergency cargo jettisoning piping system shall comply with [2.2], as appropriate, and may be led aft, external to accommodation spaces, service spaces or control stations or machinery spaces, but shall not pass through them. If an emergency cargo jettisoning piping system is permanently installed, a suitable means of isolating the piping system from the cargo piping shall be provided within the cargo area.

3.2 Bow and stern loading arrangements

3.2.1 Subject to the requirements of Ch 9, Sec 3, [1.8], this sub-article and [10.1], cargo piping may be arranged to permit bow or stern loading and unloading.

3.2.2 Arrangements shall be made to allow such piping to be purged and gas-freed after use. When not in use, the spool pieces shall be removed and the pipe ends blank-flanged. The vent pipes connected with the purge shall be located in the cargo area.

3.3 Turret compartment transfer systems

3.3.1 For the transfer of liquid or vapour cargo through an internal turret arrangement located outside the cargo area, the piping serving this purpose shall comply with [2.2], as applicable, [10.2] and the following:

- a) piping shall be located above the weather deck, except for the connection to the turret
- b) portable arrangements shall not be permitted, and
- c) arrangements shall be made to allow such piping to be purged and gas-freed after use. When not in use, the spool pieces for isolation from the cargo piping shall be removed and the pipe ends blank-flanged. The vent pipes connected with the purge shall be located in the cargo area.

3.4 Gas fuel piping systems

3.4.1 Gas fuel piping in machinery spaces shall comply with all applicable requirements of this Section in addition to the requirements of Ch 9, Sec 16.

4 Design pressure

4.1

4.1.1 The design pressure P_o , used to determine minimum scantlings of piping and piping system components, shall be not less than the maximum gauge pressure to which the system may be subjected in service. The minimum design pressure used shall not be less than 1 MPa gauge, except for open-ended lines or pressure relief valve discharge lines, where it shall be not less than the lower of 0,5 MPa gauge, or 10 times the relief valve set pressure.

4.1.2 The greater of the following design conditions shall be used for piping, piping systems and components, based on the cargoes being carried:

- for vapour piping systems or components that may be separated from their relief valves and which may contain some liquid, the saturated vapour pressure at a design temperature of 45°C. Higher or lower values may be used (see Ch 9, Sec 4, [3.3.2], item b)), or
- for systems or components that may be separated from their relief valves and which contain only vapour at all times, the superheated vapour pressure at 45°C. Higher or lower values may be used (see Ch 9, Sec 4, [3.3.2], item b)), assuming an initial condition of saturated vapour in the system at the system operating pressure and temperature, or
- the MARVS of the cargo tanks and cargo processing systems, or
- the pressure setting of the associated pump or compressor discharge relief valve, or
- the maximum total discharge or loading head of the cargo piping system considering all possible pumping arrangements or the relief valve setting on a pipeline system.

Note 1: For each piping section, the maximum pressure value among those applicable in paragraph above is to be considered.

4.1.3 Those parts of the liquid piping systems that may be subjected to surge pressures shall be designed to withstand this pressure and relevant justifications are to be submitted.

4.1.4 The design pressure of the outer pipe or duct of gas fuel systems shall not be less than the maximum working pressure of the inner gas pipe. Alternatively, for gas fuel piping systems with a working pressure greater than 1 MPa, the design pressure of the outer duct shall not be less than the maximum built-up pressure arising in the annular space considering the local instantaneous peak pressure in way of any rupture and the ventilation arrangements.

The design pressure of the outer pipe or duct is either of the following:

- the maximum pressure that can act on the outer pipe or equipment enclosure after the inner pipe rupture as documented by suitable calculations taking into account the venting arrangements; or
- for gas fuel systems with inner pipe working pressure greater than 1 Mpa, the “maximum built-up pressure arising in the annular space”, after the inner pipe rupture, which is to be calculated in accordance with [4.1.5].

The expression “duct” means to include the equipment enclosure required in Ch 9, Sec 16, [4.3] (e.g. GUV enclosure) as well as the structural pipe duct intended to contain any release of gas from inner pipe or equipment. The term “structural pipe duct” means an outer duct forming part of a structure such as a hull structure or superstructure or deck house, where permitted, other than gas valve unit rooms.

4.1.5 For high-pressure piping the design pressure of the ducting is to be taken as the higher of the following:

- a) the maximum built up pressure:
 - Static pressure in way of the rupture resulting from the gas flowing in the annular space
- b) local instantaneous peak pressure in way of the rupture:
 - This pressure is to be taken as the critical pressure and is given by the following expression:

$$p^* = p_0 \left(\frac{2}{k+1} \right)^{\frac{k}{k-1}}$$

with:

- p_0 : Maximum working pressure of the inner pipe
 k : Constant pressure specific heat divided by the constant volume specific heat:
 $k = C_p / C_v$
 $k = 1,31$ for CH_4

The tangential membrane stress of a straight pipe is not to exceed the tensile strength divided by 1,5 ($R_m / 1,5$) when subjected to the above pressure. The pressure ratings of all other piping components are to reflect the same level of strength as straight pipes.

As an alternative to using the peak pressure from the above formula, the peak pressure found from representative tests can be used. Test reports must then be submitted.

5 Cargo system valve requirements

5.1

5.1.1 Every cargo tank and piping system shall be fitted with manually operated valves for isolation purposes as specified in this Article.

In addition, remotely operated valves shall also be fitted, as appropriate, as part of the emergency shutdown (ESD) system the purpose of which is to stop cargo flow or leakage in the event of an emergency when cargo liquid or vapour transfer is in progress. The ESD system is intended to return the cargo system to a safe static condition so that any remedial action can be taken. Due regard shall be given in the design of the ESD system to avoid the generation of surge pressures within the cargo transfer pipework. The equipment to be shut down on ESD activation includes manifold valves during loading or discharge, any pump or compressor, etc., transferring cargo internally or externally (e.g. to shore or another ship/barge) and cargo tank valves, if the MARVS exceeds 0,07 MPa.

5.1.2 Cargo tank connections

All liquid and vapour connections, except for safety relief valves and liquid level gauging devices, shall have shutoff valves located as close to the tank as practicable. These valves shall provide full closure and shall be capable of local manual operation. They may also be capable of remote operation.

For cargo tanks with a MARVS exceeding 0,07 MPa gauge, the above connections shall also be equipped with remotely controlled ESD valves. These valves shall be located as close to the tank as practicable. A single valve may be substituted for the two separate valves, provided the valve complies with the requirements of Ch 9, Sec 18, [3.2] and provides full closure of the line.

5.2 Cargo manifold connections

5.2.1 One remotely controlled ESD valve shall be provided at each cargo transfer connection in use to stop liquid and vapour transfer to or from the ship. Transfer connections not in use shall be isolated with suitable blank flanges.

5.2.2 If the cargo tank MARVS exceeds 0,07 MPa, an additional manual valve shall be provided for each transfer connection in use, and may be inboard or outboard of the ESD valve to suit the ship's design.

5.3

5.3.1 Excess flow valves may be used in lieu of ESD valves, if the diameter of the protected pipe does not exceed 50 mm. Excess flow valves shall close automatically at the rated closing flow of vapour or liquid as specified by the manufacturer. The piping including fittings, valves and appurtenances protected by an excess flow valve shall have a capacity greater than the rated closing flow of the excess flow valve. Excess flow valves may be designed with a bypass not exceeding the area of a 1 mm diameter circular opening to allow equalization of pressure after a shutdown activation.

5.3.2 Cargo tank connections for gauging or measuring devices need not be equipped with excess flow valves or ESD valves, provided that the devices are constructed so that the outward flow of tank contents cannot exceed that passed by a 1,5 mm diameter circular hole.

In case of tanks with an MARVS not exceeding 0.07 MPa, the outward flow of tank contents can exceed that passed by a 1,5 mm diameter circular hole.

5.3.3 All pipelines or components which may be isolated in a liquid full condition shall be protected with relief valves for thermal expansion and evaporation.

Note 1: For pipe sections that would be closed by ESD system, a fire scenario is to be considered for sizing, as defined in [5.3.4].

5.3.4 All pipelines or components which may be isolated automatically due to a fire with a liquid volume of more than 0,05 m³ entrapped shall be provided with PRVs sized for a fire condition.

5.3.5 Pressure relief valves are to be set to discharge at a pressure not greater than the design pressure such that the overpressure during discharge does not exceed 110% of the design pressure, as defined in Ch 9, Sec 8.

6 Cargo transfer arrangements

6.1 General

6.1.1 When two or more pumps located in different cargo tanks are operating at the same time discharging into a common header, the stopping of the pumps is to activate an alarm at the centralised cargo control location.

6.1.2 Where cargo transfer is by means of cargo pumps that are not accessible for repair with the tanks in service, at least two separate means shall be provided to transfer cargo from each cargo tank, and the design shall be such that failure of one cargo pump or means of transfer will not prevent the cargo transfer by another pump or pumps, or other cargo transfer means.

6.1.3 The procedure for transfer of cargo by gas pressurization shall preclude lifting of the relief valves during such transfer. Gas pressurization may be accepted as a means of transfer of cargo for those tanks where the design factor of safety is not reduced under the conditions prevailing during the cargo transfer operation. If the cargo tank relief valves or set pressure are changed for this purpose, as it is permitted in accordance with Ch 9, Sec 8, [2.1.9] and Ch 9, Sec 8, [2.1.10], the new set pressure shall not exceed P_h as is defined in Ch 9, Sec 4, [3.3.2].

6.2 Vapour return connections

6.2.1 Connections for vapour return to the shore installations shall be provided.

6.3 Cargo tank vent piping systems

6.3.1 The pressure relief system shall be connected to a vent piping system designed to minimize the possibility of cargo vapour accumulating on the decks, or entering accommodation spaces, service spaces, control stations and machinery spaces, or other spaces where it may create a dangerous condition.

6.4 Cargo sampling connections

6.4.1 Connections to cargo piping systems for taking cargo liquid samples shall be clearly marked and shall be designed to minimize the release of cargo vapours. For vessels permitted to carry toxic products, the sampling system shall be of a closed loop design to ensure that cargo liquid and vapour are not vented to atmosphere.

Note 1: These requirements are only applicable if such a sampling system is fitted on board. Connections used for control of atmosphere in cargo tanks during inerting or gassing up are not considered as cargo sampling connections.

6.4.2 Liquid sampling systems shall be provided with two valves on the sample inlet. One of these valves shall be of the multi-turn type to avoid accidental opening, and shall be spaced far enough apart to ensure that they can isolate the line if there is blockage, by ice or hydrates for example.

6.4.3 On closed loop systems, the valves on the return pipe shall also comply with [6.4.2].

6.4.4 The connection to the sample container shall comply with recognized standards and be supported so as to be able to support the weight of a sample container. Threaded connections shall be tack-welded, or otherwise locked, to prevent them

being unscrewed during the normal connection and disconnection of sample containers. The sample connection shall be fitted with a closure plug or flange to prevent any leakage when the connection is not in use.

6.4.5 Sample connections used only for vapour samples may be fitted with a single valve in accordance with Articles [5], [8] and [13], and shall also be fitted with a closure plug or flange.

6.4.6 Sampling operations shall be undertaken as prescribed in IGC Code, Chapter 18, [18.9].

6.5 Cargo filters

6.5.1 The cargo liquid and vapour systems shall be capable of being fitted with filters to protect against damage by extraneous objects. Such filters may be permanent or temporary, and the standards of filtration shall be appropriate to the risk of debris, etc., entering the cargo system. Means shall be provided to indicate that filters are becoming blocked, and to isolate, depressurize and clean the filters safely.

Means to indicate that filters are becoming blocked and filter maintenance is required is to be provided for fixed in-line filter arrangement and portable filter installations where dedicated filter housing piping is provided.

Where portable filters for fitting to manifold presentation flanges are used without dedicated filter housing, and these can be visually inspected after each loading and discharging operation, no additional arrangements for indicating blockage or facilitating drainage are required.

7 Installation requirements

7.1 Design for expansion and contraction

7.1.1 Provision shall be made to protect the piping, piping system and components and cargo tanks from excessive stresses due to thermal movement and from movements of the tank and hull structure. The preferred method outside the cargo tanks is by means of offsets, bends or loops, but multi-layer bellows may be used if offsets, bends or loops are not practicable.

7.2 Precautions against low temperature

7.2.1 Low temperature piping shall be thermally isolated from the adjacent hull structure, where necessary, to prevent the temperature of the hull from falling below the design temperature of the hull material. Where liquid piping is dismantled regularly, or where liquid leakage may be anticipated, such as at shore connections and at pump seals, protection for the hull beneath shall be provided.

7.2.2 Where the piping system is intended for liquids having a boiling point lower than 30°C, permanent means to avoid possibility of contact between leaks and hull structures are to be provided in all those locations where leakage might be expected, such as shore connections, pump seals, flanges subject to frequent dismantling, etc.

7.2.3 The means to detect the presence of liquid cargo may be constituted by electrical level switches whose circuit is intrinsically safe. The alarm signals given by the level switches are to be transmitted to the wheelhouse and to the cargo control station, if provided.

7.2.4 High temperature pipes are to be thermally isolated from the adjacent structures. In particular, the temperature of pipelines is not to exceed 220°C in gas-dangerous zones.

7.3 Water curtain

7.3.1 For cargo temperatures below -110°C, a water distribution system shall be fitted in way of the hull under the shore connections to provide a low-pressure water curtain for additional protection of the hull steel and the ship's side structure. This system is in addition to the requirements of Ch 9, Sec 11, [1.3.2], d), and shall be operated when cargo transfer is in progress.

Note 1: The flow is to be the same as required for water spray system defined in Ch 9, Sec 11.

7.4 Bonding

7.4.1 Where tanks or cargo piping and piping equipment are separated from the ship's structure by thermal isolation, provision shall be made for electrically bonding both the piping and the tanks. All gasketed pipe joints and hose connections shall be electrically bonded. Except where bonding straps are used, it shall be demonstrated that the electrical resistance of each joint or connection is less than 1MΩ.

7.4.2 Bonding straps are required for cargo and slop tanks, piping systems and equipment which are not permanently connected to the hull of the ship, for example:

- a) independent cargo tanks
- b) cargo tank piping systems which are electrically separated from the hull of the ship
- c) pipe connections arranged for the removal of the spool pieces.

Where bonding straps are required, they are to be:

- a) clearly visible so that any shortcoming can be clearly detected
- b) designed and sited so that they are protected against mechanical damage and are not affected by high resistivity contamination, e.g. corrosive products or paint
- c) easy to install and replace.

8 Piping fabrication and joining details

8.1 General

8.1.1 *The requirements of this Article apply to piping inside and outside the cargo tanks. Relaxation from these requirements may be accepted, in accordance with recognized standards for piping inside cargo tanks and open-ended piping.*

8.2 Direct connections

8.2.1 *The following direct connection of pipe lengths, without flanges, may be considered:*

- *butt-welded joints with complete penetration at the root may be used in all applications. For design temperatures colder than -10°C , butt welds shall be either double welded or equivalent to a double welded butt joint. This may be accomplished by use of a backing ring, consumable insert or inert gas backup on the first pass. For design pressures in excess of 1 MPa and design temperatures of -10°C or colder, backing rings shall be removed*
- *slip-on welded joints with sleeves and related welding, having dimensions in accordance with recognized standards, shall only be used for instrument lines and open-ended lines with an external diameter of 50 mm or less and design temperatures not colder than -55°C , and*
- *screwed couplings complying with recognized standards shall only be used for accessory lines and instrumentation lines with external diameters of 25 mm or less.*

8.3 Flanged connections

8.3.1 *Flanges in flanged connections shall be of the welded neck, slip-on or socket welded type.*

8.3.2 *Flanges shall comply with recognized standards for their type, manufacture and test. For all piping, except open ended, the following restrictions apply:*

- *for design temperatures colder than -55°C , only welded-neck flanges shall be used, and*
- *for design temperatures colder than -10°C , slip-on flanges shall not be used in nominal sizes above 100 mm and socket welded flanges shall not be used in nominal sizes above 50 mm.*

8.4 Expansion joints

8.4.1 *Where bellows and expansion joints are provided in accordance with [7.1], the following requirements apply:*

- *if necessary, bellows shall be protected against icing, and*
- *slip joints shall not be used except within the cargo tanks.*

8.5 Other connections

8.5.1 *Piping connections shall be joined in accordance with [8.2] to [8.4], but for other exceptional cases the Society may consider alternative arrangements.*

9 Welding, post-weld heat treatment and non-destructive testing

9.1 General

9.1.1 *Welding shall be carried out in accordance with Ch 9, Sec 6, [5].*

9.2 Post-weld heat treatment

9.2.1 *Post-weld heat treatment shall be required for all butt welds of pipes made with carbon, carbon-manganese and low alloy steels. The Society may waive the requirements for thermal stress relieving of pipes with wall thickness less than 10 mm in relation to the design temperature and pressure of the piping system concerned.*

9.3 Non-destructive testing

9.3.1 In addition to normal controls before and during the welding, and to the visual inspection of the finished welds, as necessary for proving that the welding has been carried out correctly and according to the requirements of this Article, the following tests shall be required:

- a) 100% radiographic or ultrasonic inspection of butt-welded joints for piping systems with design temperatures colder than – 10°C, and with inside diameters of more than 75 mm, or wall thicknesses greater than 10 mm
- b) when such butt-welded joints of piping sections are made by automatic welding procedures approved by the Society, then a progressive reduction in the extent of radiographic or ultrasonic inspection can be agreed, but in no case to less than 10% of each joint. If defects are revealed, the extent of examination shall be increased to 100% and shall include inspection of previously accepted welds. This approval can only be granted if well-documented quality assurance procedures and records are available to assess the ability of the manufacturer to produce satisfactory welds consistently, and
- c) for other butt-welded joints of pipes not covered by items a) and b), spot radiographic or ultrasonic inspection or other non-destructive tests shall be carried out depending upon service, position and materials. In general, at least 10% of butt-welded joints of pipes shall be subjected to radiographic or ultrasonic inspection.

10 Installation requirements for cargo piping outside the cargo area

10.1 Bow and stern loading arrangements

10.1.1 The following requirements shall apply to cargo piping and related piping equipment located outside the cargo area:

- cargo piping and related piping equipment outside the cargo area shall have only welded connections. The piping outside the cargo area shall run on the weather decks and shall be at least 0,8 m inboard, except for athwartships shore connection piping. Such piping shall be clearly identified and fitted with a shutoff valve at its connection to the cargo piping system within the cargo area. At this location, it shall also be capable of being separated by means of a removable spool piece and blank flanges, when not in use, and
- the piping shall be full penetration butt-welded and subjected to full radiographic or ultrasonic inspection, regardless of pipe diameter and design temperature. Flange connections in the piping shall only be permitted within the cargo area and at the shore connection.

10.2 Turret compartment transfer systems

10.2.1 The following requirements shall apply to liquid and vapour cargo piping where it is run outside the cargo area:

- cargo piping and related piping equipment outside the cargo area shall have only welded connections, and
- the piping shall be full penetration butt-welded, and subjected to full radiographic or ultrasonic inspection, regardless of pipe diameter and design temperature. Flange connections in the piping shall only be permitted within the cargo area and at connections to cargo hoses and the turret connection.

10.3 Gas fuel piping

10.3.1 Gas fuel piping, as far as practicable, shall have welded joints. Those parts of the gas fuel piping that are not enclosed in a ventilated pipe or duct according to Ch 9, Sec 16, [4.3], and are on the weather decks outside the cargo area, shall have full penetration butt-welded joints and shall be subjected to full radiographic or ultrasonic inspection.

11 Piping system component requirements

11.1 General

11.1.1 Piping systems shall be designed in accordance with recognized standards.

11.2 Piping scantlings

11.2.1 The following criteria shall be used for determining pipe wall thickness.

11.2.2 The wall thickness of pipes t , in mm, shall not be less than:

$$t = \frac{t_0 + b + c}{1 - \frac{a}{100}}$$

where:

t_0 : Theoretical thickness, in mm, determined by the following formula:

$$t_0 = \frac{P \cdot D}{2K \cdot e + P}$$

with:

- P : Design pressure, in MPa, referred to in Article [4]
- D : Outside diameter, in mm
- K : Allowable stress, in N/mm², referred to in [11.3]
- e : Efficiency factor equal to 1 for seamless pipes and for longitudinally or spirally welded pipes, delivered by approved manufacturers of welded pipes, that are considered equivalent to seamless pipes when non-destructive testing on welds is carried out in accordance with recognized standards. In other cases, an efficiency factor of less than 1, in accordance with recognized standards, may be required, depending on the manufacturing process
- b : Allowance for bending, in mm. The value of b shall be chosen so that the calculated stress in the bend, due to internal pressure only, does not exceed the allowable stress. Where such justification is not given, b shall be:
- $$b = \frac{D \cdot t_0}{2,5r}$$
- with:
- r : Mean radius of the bend, in mm
- c : Corrosion allowance, in mm. If corrosion or erosion is expected, the wall thickness of the piping shall be increased over that required by other design requirements. This allowance shall be consistent with the expected life of the piping
- a : Negative manufacturing tolerance for thickness, in %.

11.2.3 Piping subject to green seas

In particular for piping subject to green seas, the design pressure P in the formula in [4.1] is to be replaced by an equivalent pressure P' given by the following formula:

$$P' = \frac{1}{2} \left(P + \sqrt{P^2 + 6R'K \frac{D_c}{D}} \right)$$

where:

- K : Allowable stress, in MPa.
 K is to be the lower of $(R/2,7)$ and $(R_e/1,8)$,
 where:
 R : Specified minimum tensile strength at room temperature, in MPa
 R_e : Specified lower minimum yield stress or 0,2% yield stress at room temperature, in MPa
- D : External diameter of the pipe, in mm
- D_c : External diameter of the pipe taking into account the insulation (in mm), whose thickness is to be taken at least equal to:
 40 mm if $D \leq 50$ mm
 80 mm if $D \geq 150$ mm
 Intermediate values are to be determined by interpolation.
- R' : Drag corresponding to the effect of green seas, in MPa, such as given in Tab 1 as a function of the location of the pipes and of their height H (in m) above the deepest loadline; intermediate values are to be determined by interpolation.

11.2.4 The minimum wall thickness shall be in accordance with recognized standards.

11.2.5 Where necessary for mechanical strength to prevent damage, collapse, excessive sag or buckling of pipes due to superimposed loads, the wall thickness shall be increased over that required by [11.2.2] or, if this is impracticable or would cause excessive local stresses, these loads may be reduced, protected against or eliminated by other design methods. Such superimposed loads may be due to: supporting structures, ship deflections, liquid pressure surge during transfer operations, the weight of suspended valves, reaction to loading arm connections, or otherwise.

11.3 Allowable stress

11.3.1 For pipes, the allowable stress K referred to in the formula in [11.2] is the lower of the following values:

$$\frac{R_m}{A} \text{ or } \frac{R_e}{B}$$

where:

- R_m : Specified minimum tensile strength at room temperature, in N/mm²
- R_e : Specified minimum yield stress at room temperature, in N/mm². If the stress-strain curve does not show a defined yield stress, the 0,2% proof stress applies.

The values of A and B shall be shown on the International Certificate of Fitness for the Carriage of Liquefied Gases in Bulk, and have values of at least $A = 2,7$ and $B = 1,8$.

11.4 High-pressure gas fuel outer pipes or ducting scantlings

11.4.1 In fuel gas piping systems of design pressure greater than the critical pressure, the tangential membrane stress of a straight section of pipe or ducting shall not exceed the tensile strength divided by 1,5 ($R_m/1,5$) when subjected to the design pressure specified in Article [4]. The pressure ratings of all other piping components shall reflect the same level of strength as straight pipes.

11.5 Stress analysis

11.5.1 When the design temperature is -110°C or lower, a complete stress analysis, taking into account all the stresses due to the weight of pipes, including acceleration loads if significant, internal pressure, thermal contraction and loads induced by hog and sag of the ship for each branch of the piping system shall be submitted to the Society. For temperatures above -110°C , a stress analysis may be required by the Society in relation to such matters as the design or stiffness of the piping system and the choice of materials. In any case, consideration shall be given to thermal stresses even though calculations are not submitted. The analysis may be carried out according to a code of practice acceptable to the Society.

11.5.2 When such an analysis is required, it is to be carried out in accordance with the requirements listed below. Subject to this condition, calculations in accordance with recognised standards are admitted by the Society.

11.5.3 The calculations are to be made for every possible case of operation, but only those leading to the most unfavourable results are required to be submitted.

Table 1 : Drag R' corresponding to the effect of green seas (in MPa)

External diameter of pipe (1)	Aft of the quarter of the ship's length			Forward of the quarter of the ship's length		
	H ≤ 8	H = 13	H ≥ 18	H ≤ 8	H = 13	H ≥ 18
≤ 25	0,015	0,0025	0,0015	0,022	0,0035	0,0015
50	0,014	0,0025	0,0015	0,020	0,0035	0,0015
75	0,011	0,0025	0,0015	0,016	0,0035	0,0015
100	0,007	0,0025	0,0015	0,007	0,0035	0,0015
≥150	0,005	0,0025	0,0015	0,007	0,0035	0,0015

(1) D_c if the pipe is insulated, D otherwise.

11.5.4 Loads to be taken for calculation

The calculations are to be carried out taking into account the following loads:

- a) piping not subject to green seas:
 - pressure
 - weight of the piping with insulation and of the internal fluid
 - contraction
- b) piping subject to green seas that is liable to be in operation at sea and in port:
 - pressure
 - weight of the piping with insulation and of the internal fluid
 - green seas
 - contraction
 - ship motion accelerations
- c) piping subject to green seas that is in operation only in port; the more severe of the following two combinations of loads:
 - pressure
 - weight of the piping with insulation and of the internal fluid
 - contraction
 and
 - weight of the piping with insulation
 - green seas
 - expansion, assuming that the thermal stresses are fully relaxed.

11.5.5 Green sea directions

When green seas are considered, their effects are to be studied, unless otherwise justified, in the following three directions:

- axis of the ship
- vertical
- horizontal, perpendicular to the axis of the ship. The load on the pipes is the load R' defined in [11.2.3].

11.5.6 Stress intensity

The stress intensity is to be determined as specified in the formulae in Pt C, Ch 1, Sec 10, [2.3.2] for pipes intended for high temperatures:

- a) for primary stresses resulting from:
 - pressure
 - weight
 - green seas
- b) for primary stresses and secondary stresses resulting from contraction.

11.5.7 Stress intensity limits

- a) For the first case, the stress intensity is to be limited to the lower of:
 $0,8 R_e$ and $0,4 R_m$
- b) For the second case, the stress intensity is to be limited to the lower of:
 $1,6 R_e$ and $0,8 R_m$.

11.5.8 Piping with expansion devices

For piping fitted with expansion devices, their characteristics are to be submitted to the Society. Where these characteristics are such that the forces and moments at the ends of the devices are negligible for the contraction they must absorb, the calculation of the loads due to contraction in the corresponding piping is not required. It is, however, to be checked that the stress intensity corresponding to the primary stresses does not exceed the limits given in [11.5.7].

11.5.9 Flexibility coefficient

The flexibility coefficient of elbows is to be determined from the formulae given in Pt C, Ch 1, Sec 10, [2.3.2] for pipes intended for high temperatures.

11.5.10 Local stresses

Particular attention is to be paid to the calculation of local stresses in the assemblies subjected to axial forces and bending moments. The Society reserves the right to request additional justifications or local strengthening where considered necessary.

11.6 Flanges, valves and fittings

11.6.1 *Flanges, valves and other fittings shall comply with recognized standards, taking into account the material selected and the design pressure defined in Article [4]. For bellows expansion joints used in vapour service, a lower minimum design pressure may be accepted.*

11.6.2 *For flanges not complying with a recognized standard, the dimensions of flanges and related bolts shall be to the satisfaction of the Society.*

11.6.3 For flanges not complying with a standard, the dimensions and type of gaskets are to be to the satisfaction of the Society.

11.6.4 *All emergency shutdown valves shall be of the "fail-closed" type (see [13.3.1] and Ch 9, Sec 18, [3.2]), i.e. emergency shutdown valves are to close automatically in case of fire (due to loss of actuating power).*

11.6.5 *The design and installation of expansion bellows shall be in accordance with recognized standards and be fitted with means to prevent damage due to over-extension or compression.*

11.6.6 Expansion joints are to be protected from extensions and compressions greater than the limits fixed for them and the connected piping is to be suitably supported and anchored. Bellow expansion joints are to be protected from mechanical damage.

11.7 Ship's cargo hoses

11.7.1 Ship's cargo hoses are to be type approved by the Society.

11.7.2 All hoses are to be tested at the plant of manufacturer in the presence of the Surveyor. An alternative survey scheme, BV Mode I as per NR320, may be agreed with the Society.

11.7.3 *Liquid and vapour hoses used for cargo transfer shall be compatible with the cargo and suitable for the cargo temperature.*

11.7.4 *Hoses subject to tank pressure, or the discharge pressure of pumps or vapour compressors, shall be designed for a bursting pressure not less than five times the maximum pressure the hose will be subjected to during cargo transfer.*

11.7.5 *Each new type of cargo hose, complete with end-fittings, shall be prototype-tested at a normal ambient temperature, with 200 pressure cycles from zero to at least twice the specified maximum working pressure. After this cycle pressure test has been carried out, the prototype test shall demonstrate a bursting pressure of at least 5 times its specified maximum working pressure at the upper and lower extreme service temperature. Hoses used for prototype testing shall not be used for cargo service.*

Thereafter, before being placed in service, each new length of cargo hose produced shall be hydrostatically tested at ambient temperature to a pressure not less than 1,5 times its specified maximum working pressure, but not more than two fifths of its bursting pressure. The hose shall be stencilled, or otherwise marked, with the date of testing, its specified maximum working pressure and, if used in services other than ambient temperature services, its maximum and minimum service temperature, as applicable. The specified maximum working pressure shall not be less than 1 MPa gauge.

12 Materials

12.1

12.1.1 The choice and testing of materials used in piping systems shall comply with the requirements of Ch 9, Sec 6, taking into account the minimum design temperature. However, some relaxation may be permitted in the quality of material of open-ended vent piping, provided that the temperature of the cargo at the pressure relief valve setting is not lower than -55°C , and that no liquid discharge to the vent piping can occur. Similar relaxations may be permitted under the same temperature conditions to open-ended piping inside cargo tanks, excluding discharge piping and all piping inside membrane and semi-membrane tanks.

12.1.2 Materials having a melting point below 925°C shall not be used for piping outside the cargo tanks except for short lengths of pipes attached to the cargo tanks, in which case fire-resisting insulation shall be provided.

12.1.3 Aluminised pipes may be fitted in ballast tanks, in inerted cargo tanks and, provided the pipes are protected from accidental impact, in hazardous areas on open deck.

Note 1: The paragraph [12.1.2] of the Revised IGC Code does not apply to valves installed on cargo lines or gas supply machinery.

The valve use of Teflon or PTFE will only be allowed if the valve is tested in fire and Teflon (or PTFE) can only be used for internal seals of the valve.

12.1.4 Cargo piping insulation system

Cargo piping systems shall be provided with a thermal insulation system as required to minimize heat leak into the cargo during transfer operations and to protect personnel from direct contact with cold surfaces.

Where applicable, due to location or environmental conditions, insulation materials shall have suitable properties of resistance to fire and flame spread and shall be adequately protected against penetration of water vapour and mechanical damage.

Note 1: The expression "a thermal insulation system as required to minimize heat leak into the cargo during transfer operations" means that properties of the piping insulation are to be taken into consideration when calculating the heat balance of the containment system and capacity of the pressure/temperature control system.

Note 2: The expression "cargo piping systems shall be provided with a thermal insulation system as required... to protect personnel from direct contact with cold surfaces" means that surfaces of cargo piping systems with which personnel is likely to contact under normal conditions are to be protected by a thermal insulation, with the exception of the following examples:

- surfaces of cargo piping systems which are protected by physical screening measures to prevent such direct contact
- surfaces of manual valves, having extended spindles that protect the operator from the cargo temperature, and
- surfaces of cargo piping systems whose design temperature (to be determined from inner fluid temperature) is above minus 10°C .

12.1.5 Where the cargo piping system is of a material susceptible to stress corrosion cracking in the presence of a salt-laden atmosphere, adequate measures to avoid this occurring shall be taken by considering material selection, protection of exposure to salty water and/or readiness for inspection.

A protective coating is to be applied on cargo pipes made in 304L and located on the open deck. Cargo pipes made in 316L are not required to be coated.

12.1.6 A Society certificate is to be provided for the raw material of parts of valves or pumps that will be in direct contact with cargo and with a working temperature below -55°C .

13 Testing requirements

13.1 General

13.1.1 The piping components mentioned in the present Article are subject to a type approval by the Society.

13.2 Type testing of Cargo pumps

13.2.1 Type approval

- a) Each size and type of pump is to be approved through design assessment and prototype testing. Prototype testing is to be witnessed in the presence of the Surveyor.
In lieu of prototype testing, satisfactory in-service experience, of an existing pump design approved by a Society submitted by the manufacturer may be considered
- b) Prototype testing is to include hydrostatic test of the pump body equal to 1,5 times the design pressure and a capacity test. For submerged electric motor driven pumps, the capacity test is to be carried out with the design medium or with a medium below the minimum working temperature. For shaft driven deep well pumps, the capacity test may be carried out with water.

In addition, for shaft driven deep well pumps, a spin test to demonstrate satisfactory operation of bearing clearances, wear rings and sealing arrangements is to be carried out at the minimum design temperature. The full length of shafting is not required for the spin test, but must be of sufficient length to include at least one bearing and sealing arrangements. After completion of tests, the pump is to be opened out for examination.

13.2.2 Unit production testing

- a) All pumps are to be tested at the plant of manufacturer in the presence of the Surveyor. Testing is to include hydrostatic test of the pump body equal to 1,5 times the design pressure and a capacity test. For submerged electric motor driven pumps, the capacity test is to be carried out with the design medium or with a medium below the minimum working temperature. For shaft driven deep well pumps, the capacity test may be carried out with water
- b) As an alternative to the above, if so requested by the relevant Manufacturer, the certification of a pump may be issued, subject to an alternative survey scheme as per Rule Note NR320 as amended, and the following:
 - The pump has been approved as required by [13.2.1], and
 - The manufacturer has a recognised quality system that has been assessed and certified by the Society subject to periodic audits, and
 - The quality control plan contains a provision to subject each pump to a hydrostatic test of the pump body equal to 1,5 times the design pressure and a capacity test. The manufacturer is to maintain records of such tests.

13.3 Type testing of Valves

13.3.1 General

Each type of valve intended to be used at a working temperature below -55°C shall be subject to the following type tests:

- each size and type of valve shall be subjected to seat tightness testing over the full range of operating pressures for bi-directional flow and temperatures, at intervals, up to the rated design pressure of the valve. Allowable leakage rates shall be to the requirements of the Society. During the testing, satisfactory operation of the valve shall be verified
- the flow or capacity shall be certified to a recognized standard for each size and type of valve

Note 1: For pressure relief valves (PRVs) that are subject to requirement of Ch 9, Sec 8, [2.1.7], the flow or capacity are to be certified by the Society.

For other types of valves, the manufacturer is to certify the flow properties of the valves based on tests carried out according to recognized standards.

- pressurized components shall be pressure tested to at least 1,5 times the rated pressure, and
- for emergency shutdown valves, with materials having melting temperatures lower than 925°C , the type testing shall include a fire test to a standard acceptable to the Society.

Note 2: Refer to SIGTTO Publication on "The Selection and Testing of Valves for LNG Applications".

Note 3: "Emergency shutdown valves, with materials having melting temperatures lower than 925°C " does not include an emergency shutdown valve in which components made of materials having melting temperatures lower than 925°C do not contribute to the shell or seat tightness of the valve.

13.3.2 Type approval

Each size and type of valve intended to be used at a working temperature below -55°C is to be approved through design assessment and prototype testing. Prototype testing for all valves to the minimum design temperature or lower and to a pressure not lower than the maximum design pressure foreseen for the valves is to be witnessed in the presence of the Surveyor. Prototype testing is to include hydrostatic test of the valve body at a pressure equal to 1,5 times the design pressure, and cryogenic testing consisting of valve operation or safety valve set pressure, and leakage verification. In addition, for valves other than safety valves, a seat and stem leakage test at a pressure equal to 1,1 times the design pressure.

For valves intended to be used at a working temperature above -55°C , prototype testing is not required.

13.3.3 Unit production testing

All valves are to be tested at the plant of manufacturer in the presence of the Surveyor. Testing is to include hydrostatic test of the valve body at a pressure equal to 1,5 times the design pressure for all valves, seat and stem leakage test at a pressure equal to 1,1 times the design pressure for valves other than safety valves. In addition, cryogenic testing consisting of valve operation and leakage verification for a minimum of 10% of each type and size of valve for valves other than safety valves intended to be used at a working temperature below -55°C . The set pressure of safety valves is to be tested at ambient temperature.

For valves used for isolation of instrumentation in piping not greater than 25mm, unit production testing need not be witnessed by the surveyor. Records of testing are to be available for review.

As an alternative to the above, if so requested by the relevant Manufacturer, the certification of a valve may be issued, subject to an alternative survey scheme as per Rule Note NR320 as amended, and the following:

- The valve has been approved as required by [13.3.2] for valves intended to be used at a working temperature below -55°C , and
- The manufacturer has a recognized quality system that has been assessed and certified by the Society subject to periodic audits, and
- The quality control plan contains a provision to subject each valve to a hydrostatic test of the valve body at a pressure equal to 1,5 times the design pressure for all valves and seat and stem leakage test at a pressure equal to 1,1 times the design

pressure for valves other than safety valves. The set pressure of safety valves is to be tested at ambient temperature. The manufacturer is to maintain records of such tests, and

- Cryogenic testing consisting of valve operation and leakage verification for a minimum of 10% of each type and size of valve for valves other than safety valves intended to be used at a working temperature below -55°C in the presence of the Surveyor.

13.4 Type testing of expansion bellows

13.4.1 General

The following type tests shall be performed on each type of expansion bellows intended for use on cargo piping outside the cargo tank and where required by the Society, on those installed within the cargo tanks:

- *elements of the bellows, not pre-compressed, shall be pressure tested at not less than five times the design pressure without bursting. The duration of the test shall not be less than 5 min*
- *a pressure test shall be performed on a type expansion joint, complete with all the accessories such as flanges, stays and articulations, at the minimum design temperature and twice the design pressure at the extreme displacement conditions recommended by the manufacturer, without permanent deformation*
- *a cyclic test (thermal movements) shall be performed on a complete expansion joint, which shall withstand at least as many cycles under the conditions of pressure, temperature, axial movement, rotational movement and transverse movement as it will encounter in actual service. Testing at ambient temperature is permitted when this testing is at least as severe as testing at the service temperature, and*
- *a cyclic fatigue test (ship deformation) shall be performed on a complete expansion joint, without internal pressure, by simulating the bellows movement corresponding to a compensated pipe length, for at least 2000000 cycles at a frequency not higher than 5 Hz. This test is only required when, due to the piping arrangement, ship deformation loads are actually experienced.*

13.4.2 Unit production testing

All bellows are to be tested at the plant of manufacturer in the presence of the Surveyor. Testing is to include hydro- static test of the bellow at a pressure equal to 1,5 times the design pressure. An alternative survey scheme, BV Mode I as per NR320, may be agreed with the Society.

13.5 System testing requirements

13.5.1 *The requirements of this sub-article shall apply to piping inside and outside the cargo tanks.*

13.5.2 *After assembly, all cargo and process piping shall be subjected to a strength test with a suitable fluid. The test pressure shall be at least 1,5 times the design pressure (1,25 times the design pressure where the test fluid is compressible) for liquid lines and 1,5 times the maximum system working pressure (1,25 times the maximum system working pressure where the test fluid is compressible) for vapour lines. When piping systems or parts of systems are completely manufactured and equipped with all fittings, the test may be conducted prior to installation on board the ship, as defined in Pt C, Ch 1, Sec 10, [20.5.1]. Joints welded on board shall be tested to at least 1,5 times the design pressure.*

Note 1: IMO wanted to distinguish between the pneumatic test with air or other gas (compressible fluid) and the hydraulic test with water (incompressible fluid).

13.5.3 *After assembly on board, each cargo and process piping system shall be subjected to a leak test using air, or other suitable medium, to a pressure depending on the leak detection method applied.*

13.5.4 *In double wall gas-fuel piping systems, the outer pipe or duct shall also be pressure tested to show that it can withstand the expected maximum pressure at gas pipe rupture.*

The expression "duct" means to include the equipment enclosure required in Ch 9, Sec 16, [4.3] (e.g. GUV enclosure) as well as the structural pipe duct intended to contain any release of gas from inner pipe or equipment. The term "structural pipe duct" means an outer duct forming part of a structure such as a hull structure or superstructure or deck house, where permitted, other than gas valve unit rooms.

The expression "maximum pressure at gas pipe rupture" is the maximum pressure to which the outer pipe or duct is subjected after the inner pipe rupture and for testing purposes it is the same as the design pressure used in [4.1.4].

13.5.5 *All piping systems, including valves, fittings and associated equipment for handling cargo or vapours, shall be tested under normal operating conditions not later than at the first loading operation, in accordance with recognized standards.*

13.5.6 Attention is drawn to the requirements of Ch 9, Sec 1, [6.2.4] regarding the examination of the on-deck cargo piping system, that are to be conducted on ships carrying liquefied natural gases (LNG) in bulk during the first full loading and the subsequent first unloading of the ship.

13.6 Emergency shutdown valves

13.6.1 *The closing characteristics of emergency shutdown valves used in liquid cargo piping systems shall be tested to demonstrate compliance with Ch 9, Sec 18, [3.2.1], item c). This testing may be carried out on board after installation.*

Section 6 Materials of Construction and Quality Control

1 Definitions

1.1

1.1.1 Where reference is made in this Section to A, B, D, E, AH, DH, EH and FH hull structural steels, these steel grades are hull structural steels according to recognized standards.

1.1.2 Piece

A piece is the rolled product from a single slab or billet or from a single ingot, if this is rolled directly into plates, strips, sections or bars.

1.1.3 Batch

A batch is the number of items or pieces to be accepted or rejected together, on the basis of the tests to be carried out on a sampling basis. The size of a batch is given in the recognized standards.

1.1.4 Controlled rolling (CR)

Controlled rolling (CR) is a rolling procedure in which the final deformation is carried out in the normalizing temperature range, resulting in a material condition generally equivalent to that obtained by normalizing.

1.1.5 Thermo-mechanical controlled processing (TMCP)

Thermo-mechanical controlled processing (TMCP) is a procedure that involves strict control of both the steel temperature and the rolling reduction. Unlike CR, the properties conferred by TMCP cannot be reproduced by subsequent normalizing or other heat treatment. The use of accelerated cooling on completion of TMCP may also be accepted, subject to approval by the Society. The same applies for the use of tempering after completion of TMCP.

1.1.6 Accelerated cooling (AcC)

Accelerated cooling (AcC) is a process that aims to improve mechanical properties by controlled cooling with rates higher than air cooling, immediately after the final TMCP operation. Direct quenching is excluded from accelerated cooling. The material properties conferred by TMCP and AcC cannot be reproduced by subsequent normalizing or other heat treatment.

2 Scope and general requirements

2.1

2.1.1 This Section gives the requirements for metallic and non-metallic materials used in the construction of the cargo system. This includes requirements for joining processes, production process, personnel qualification, NDT and inspection and testing including production testing. The requirements for rolled materials, forgings and castings are given in Article [4] and in Tab 2 to Tab 6. The requirements for weldments are given in Article [5], and the guidance for non-metallic materials is given in Appendix 4 of the IGC Code. A quality assurance/ quality control programme shall be implemented to ensure that the requirements of this Article [2] are complied with.

2.1.2 The manufacture, testing, inspection and documentation shall be in accordance with recognized standards and the specific requirements given in the Code.

2.1.3 Where post-weld heat treatment is specified or required, the properties of the base material shall be determined in the heat-treated condition, in accordance with the applicable table of this Section, and the weld properties shall be determined in the heat treated condition in accordance with Article [5]. In cases where a post-weld heat treatment is applied, the test requirements may be modified at the discretion of the Society.

3 General test requirements and specifications

3.1 Tensile test

3.1.1 Tensile testing shall be carried out in accordance with recognized standards.

3.1.2 Tensile strength, yield stress and elongation shall be to the satisfaction of the Society. For carbon-manganese steel and other materials with definitive yield points, consideration shall be given to the limitation of the yield to tensile ratio.

Note 1: The test specimens and mechanical testing procedures for materials are defined in NR216 Materials and Welding, and reference should be made to international standard as ISO, etc...

3.2 Toughness test

3.2.1 Acceptance tests for metallic materials shall include Charpy V-notch toughness tests, unless otherwise specified by the Society. The specified Charpy V-notch requirements are minimum average energy values for three full size (10 mm x 10 mm) specimens and minimum single energy values for individual specimens. Dimensions and tolerances of Charpy V-notch specimens shall be in accordance with recognized standards. The testing and requirements for specimens smaller than 5 mm in size shall be in accordance with recognized standards. Minimum average values for subsized specimens shall be as defined in Tab 1. Only one individual value may be below the specified average value, provided it is not less than 70% of that value.

Table 1 : Minimum average energy values for subsized specimens

Charpy V-notch specimen size (mm)	Minimum average energy of three specimens
10 x 10	KV
10 x 7,5	5/6 KV
10 x 5,0	2/3 KV

Note 1: KV : Energy values, in J, specified in Tab 2 to Tab 5.

3.2.2 For base metal, the largest size Charpy V-notch specimens possible for the material thickness shall be machined with the specimens located as near as practicable to a point midway between the surface and the centre of the thickness and the length of the notch perpendicular to the surface as shown in Fig 1.

Note 1: In the case where the material thickness is 40mm or below, the Charpy V-notch impact test specimens are to be cut with their edge within 2mm from the “as rolled” surface with their longitudinal axes either parallel or transverse to the final direction of rolling of the material.

3.2.3 For a weld test specimen, the largest size Charpy V-notch specimens possible for the material thickness shall be machined, with the specimens located as near as practicable to a point midway between the surface and the centre of the thickness. In all cases, the distance from the surface of the material to the edge of the specimen shall be approximately 1 mm or greater. In addition, for double-V butt welds, specimens shall be machined closer to the surface of the second welded section. The specimens shall be taken generally at each of the five following locations, as shown in Fig 2: on the centreline of the welds, the fusion line and 1 mm, 3 mm and 5 mm from the fusion line.

Figure 1 : Orientation of base metal test specimen

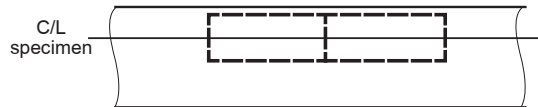
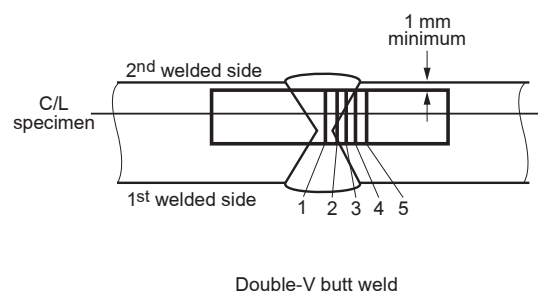
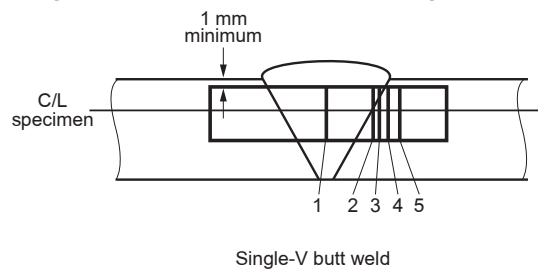

Figure 2 : Orientation of weld test specimen



3.2.4 *If the average value of the three initial Charpy V-notch specimens fails to meet the stated requirements, or the value for more than one specimen is below the required average value, or when the value for one specimen is below the minimum value permitted for a single specimen, three additional specimens from the same material may be tested and the results be combined with those previously obtained to form a new average. If this new average complies with the requirements and if no more than two individual results are lower than the required average and no more than one result is lower than the required value for a single specimen, the piece or batch may be accepted.*

3.3 Bend test

3.3.1 *The bend test may be omitted as a material acceptance test, but is required for weld tests. Where a bend test is performed, this shall be done in accordance with recognized standards.*

3.3.2 *The bend tests shall be transverse bend tests, which may be face, root or side bends at the discretion of the Society. However, longitudinal bend tests may be required in lieu of transverse bend tests in cases where the base material and weld metal have different strength levels.*

3.4 Section observation and other testing

3.4.1 *Macrosection, microsection observations and hardness tests may also be required by the Society, and they shall be carried out in accordance with recognized standards, where required.*

4 Requirements for metallic materials

4.1 General requirements for metallic materials

4.1.1 The use of high manganese austenitic steel for cryogenic service may be permitted in accordance with IACS Recommendation No.169.

Refer also to IMO Circular MSC.1/Circ.1599: Interim guidelines on the application of high manganese austenitic steel for cryogenic service.

4.1.2 The use of aluminium coatings is prohibited in the cargo tanks, cargo tank deck area, pump rooms, cofferdams or any other area where cargo gas may accumulate.

4.1.3 *The requirements for materials of construction are shown in the tables as follows:*

- *Tab 2: Plates, pipes (seamless and welded), sections and forgings for cargo tanks and process pressure vessels for design temperatures not lower than 0°C*
- *Tab 3: Plates, sections and forgings for cargo tanks, secondary barriers and process pressure vessels for design temperatures below 0°C and down to -55°C*
- *Tab 4: Plates, sections and forgings for cargo tanks, secondary barriers and process pressure vessels for design temperatures below -55°C and down to -165°C*
- *Tab 5: Pipes (seamless and welded), forgings and castings for cargo and process piping for design temperatures below 0°C and down to -165°C*
- *Tab 6: Plates and sections for hull structures required by Ch 9, Sec 4, [6.2.2] and Ch 9, Sec 4, [6.2.3].*

4.1.4 Impact tests are required for:

- castings in steel grades 304, 304L, 321 and 347 when the service temperature is below -60°C
- castings in steel grades 316 and 316L (which contain molybdenum) at any temperature. A reduction of the tests may be granted for design temperatures above -60°C after examination of each case by the Society.

Table 2 : Plates, pipes (seamless and welded) -see Note 1 and Note 2-, sections and forgings for cargo tanks and process pressure vessels for design temperatures not lower than 0°C

CHEMICAL COMPOSITION AND HEAT TREATMENT	
• Carbon-manganese steel	
• Fully killed fine grain steel	
• Small additions of alloying elements by agreement with the Society	
• Composition limits to be approved by the Society	
• Normalized, or quenched and tempered (1)	

TENSILE AND TOUGHNESS (IMPACT) TEST REQUIREMENTS				
Sampling frequency	• Plates	Each "piece" to be tested		
	• Sections and forgings	Each "batch" to be tested		
Mechanical properties	• Tensile properties	Specified minimum yield stress not to exceed 410 N/mm ² (2)		
Toughness (Charpy V-notch test)	• Plates	Transverse test pieces. Minimum average energy value (KV) 27 J		
	• Sections and forgings	Longitudinal test pieces. Minimum average energy value (KV) 41 J		
	• Test temperature (3)	Thickness t (mm)	Test temperature	
		t ≤ 20	0°C	
		20 < t ≤ 40	-20°C	
		40 < t ≤ 50 (4)	-20°C (5)	
40 < t ≤ 50 (4)	-30°C (6)			

- (1)** A controlled rolling procedure or TMCP may be used as an alternative.
- (2)** Materials with specified minimum yield stress exceeding 410 N/mm² may be approved by the Society. For these materials, particular attention shall be given to the hardness of the welded and heat affected zones.
- (3)** This Table is generally applicable for material thicknesses t up to 40 mm. Proposals for greater thicknesses shall be approved by the Society.
- (4)** A further set of impact test at mid thickness for products with t>40mm is required except rolled steels specified in IACS UR W11 or IACS UR W16.
- (5)** Applies to type C independent tanks and process pressure vessels. In addition, post-weld stress relief heat treatment shall be performed. Exemption to post-weld stress relief heat treatment based on alternative approach (e.g. Engineering Critical Assessment) shall be approved by the Classification Society or shall be to recognized standards.
- (6)** Applies to cargo tank other than type C.
- Note 1:** For seamless pipes and fittings normal practice applies. The use of longitudinally and spirally welded pipes shall be specially approved by the Society.
- Note 2:** Charpy V-notch impact tests are not required for pipes.

Table 3 : Plates, sections and forgings -see Note 1- for cargo tanks, secondary barriers and process pressure vessels for design temperatures below 0°C and down to -55°C

CHEMICAL COMPOSITION AND HEAT TREATMENT	
<ul style="list-style-type: none"> Carbon-manganese steel 	
<ul style="list-style-type: none"> Fully killed, aluminium treated fine grain steel 	
<ul style="list-style-type: none"> Chemical composition (ladle analysis): C: 0,16% max (1) ; Mn: 0,70-1,60% ; Si: 0,10-0,50% ; S: 0,025% max ; P: 0,025% max 	
<ul style="list-style-type: none"> Optional additions: Alloys and grain refining elements may be generally in accordance with the following: Ni: 0,80% max ; Cr: 0,25% max ; Mo: 0,08% max ; Cu:0,35% max ; Nb: 0,05% max ; V: 0,10% max Al content total: 0,020% min (acid soluble: 0,015% min) 	
<ul style="list-style-type: none"> Normalized, or quenched and tempered (2) 	

TENSILE AND TOUGHNESS (IMPACT) TEST REQUIREMENTS		
Sampling frequency	<ul style="list-style-type: none"> Plates 	Each "piece" to be tested
	<ul style="list-style-type: none"> Sections and forgings 	Each "batch" to be tested
Mechanical properties	<ul style="list-style-type: none"> Tensile properties 	Specified minimum yield stress not to exceed 410 N/mm ² (3)
Toughness (Charpy V-notch test)	<ul style="list-style-type: none"> Plates 	Transverse test pieces. Minimum average energy value (KV) 27 J
	<ul style="list-style-type: none"> Sections and forgings 	Longitudinal test pieces. Minimum average energy value (KV) 41 J
	<ul style="list-style-type: none"> Test temperature, t ≤ 25 mm (4) 	5°C below the design temperature or -20°C, whichever is lower

- (1)** By special agreement with the Society, the carbon content may be increased to 0,18% maximum, provided the design temperature is not lower than -40°C.
- (2)** A controlled rolling procedure or TMCP may be used as an alternative.
- (3)** Materials with specified minimum yield stress exceeding 410 N/mm² may be approved by the Society. For these materials, particular attention shall be given to the hardness of the welded and heat affected zones.
- (4)** This Table is applicable for material thicknesses t up to 25 mm. For material thicknesses of more than 25 mm, Charpy V-notch tests shall be conducted at the following temperatures:

Thickness t (mm)	Test temperature
25 mm < t ≤ 30 mm	10°C below the design temperature or -20°C, whichever is lower
30 mm < t ≤ 35 mm	15°C below the design temperature or -20°C, whichever is lower
35 mm < t ≤ 40 mm	20°C below the design temperature
40 mm < t ≤ 50 mm (a)	5°C below the design temperature or -20°C, whichever is lower (b)
40 mm < t ≤ 45 mm (a)	25°C below the design temperature (c)
45 mm < t ≤ 50 mm (a)	30°C below the design temperature (c)

The impact energy value shall be in accordance with the Table for the applicable type of test specimen.

Materials for tanks and parts of tanks which are completely thermally stress relieved after welding may be tested at a temperature 5°C below design temperature or -20°C, whichever is lower.

For thermally stress relieved reinforcements and other fittings, the test temperature shall be the same as that required for the adjacent tank-shell thickness.

- (a)** A further set of impact test at mid thickness for products with t > 40 mm is required except rolled steels specified in IACS UR W11 or IACS UR W16.
- (b)**
- For design temperatures below 0°C and strictly down to -10°C:
Applies to type C independent tanks and process pressure vessels. In addition, post-weld stress relief heat treatment shall be performed. Exemption to post-weld stress relief heat treatment based on alternative approach (e.g. Engineering Critical Assessment) shall be approved by the Classification Society or shall be to recognized standards.
 - For design temperatures below -10°C and down to -55°C:
[6.2.2] applies with regards to post-weld stress relief heat treatment. Exemption to post-weld stress relief heat treatment based on alternative approach (e.g. Engineering Critical Assessment) shall be approved by the Classification Society or shall be to recognized standards.
- (c)** Applies to cargo tank other than type C.

Note 1: The Charpy V-notch and chemistry requirements for forgings may be specially considered by the Society.

Note 2: For materials exceeding 25 mm in thickness for which the test temperature is -60°C or lower, the application of specially treated steels or steels in accordance with Table 4 may be necessary.

Table 4 : Plates, sections and forgings -see Note 1- for cargo tanks, secondary barriers and process pressure vessels for design temperatures below –55°C and down to –165°C

Minimum design temperature (1)	CHEMICAL COMPOSITION (2) AND HEAT TREATMENT	Impact test temperature	
–60°C	1,5% nickel steel – normalized or normalized and tempered or quenched and tempered or TMCP (5)	t ≤ 25 mm (3)	–65°C
–65°C	2,25% nickel steel – normalized or normalized and tempered or quenched and tempered or TMCP (5) (6)		–70°C
–90°C	3,5% nickel steel – normalized or normalized and tempered or quenched and tempered or TMCP (5) (6)		–95°C
–105°C	5,0% nickel steel – normalized or normalized and tempered or quenched and tempered (5) (6) (7)		–110°C
–165°C	9,0% nickel steel – double normalized and tempered or quenched and tempered (5)	(4)	–196°C
–165°C	Austenitic steels, such as types 304, 304L, 316, 316L, 321 and 347. Solution treated (8)		–196°C
–165°C	Aluminium alloys, such as type 5083 annealed		Not required
–165°C	Austenitic Fe-Ni alloy (36% nickel). Heat treatment as agreed		Not required

TENSILE AND TOUGHNESS (IMPACT) TEST REQUIREMENTS

Sampling frequency	• Plates	Each "piece" to be tested
	• Sections and forgings	Each "batch" to be tested
Toughness (Charpy V-notch test)	• Plates	Transverse test pieces. Minimum average energy value (KV) 27 J
	• Sections and forgings	Longitudinal test pieces. Minimum average energy value (KV) 41 J

- (1) The requirements for design temperatures below –165°C shall be specially agreed with the Society.
- (2) The chemical composition limits shall be in accordance with recognized standards.
- (3) This Table is applicable for material thicknesses t up to 25 mm. For materials 1,5% Ni, 2,25% Ni, 3,5% Ni and 5,0% Ni, with thicknesses greater than 25 mm, the impact tests shall be conducted at the following temperatures:

Thickness t (mm)	Test temperature
25 mm < t ≤ 30 mm	10°C below the design temperature
30 mm < t ≤ 35 mm	15°C below the design temperature
35 mm < t ≤ 40 mm	20°C below the design temperature
40 mm < t ≤ 45 mm (a)	25°C below the design temperature
45 mm < t ≤ 50 mm (a)	30°C below the design temperature

The energy value shall be in accordance with the Table for the applicable type of test specimen.

- (a) A further set of impact test at mid thickness for products with t>40mm is required except rolled steels specified in IACS UR W11 or IACS UR W16.
- (4) For 9,0% Ni steels, austenitic stainless steels and aluminium alloys, thickness greater than 25 mm may be used.
- (5) TMCP nickel steels will be subject to acceptance by the Society.
- (6) A lower minimum design temperature for quenched and tempered steels may be specially agreed with the Society.
- (7) A specially heat treated 5,0% nickel steel, for example triple heat treated 5,0% nickel steel, may be used down to –165°C, provided that the impact tests are carried out at –196°C.
- (8) The impact test of austenitic stainless steel is required only for service temperature less than –105°C.

Note 1: The impact test required for forgings used in critical applications shall be subject to special consideration by the Society.

Table 5 : Pipes (seamless and welded) -see Note 1-, forgings and castings -see Note 2- for cargo and process piping for design temperatures below 0°C and down to -165°C

Minimum design temperature (1)	CHEMICAL COMPOSITION (2) AND HEAT TREATMENT	Impact test, t ≤ 25 mm	
		Test temperature	Minimum average energy (KV)
-55°C	Carbon-manganese steel. Fully killed fine grain. Normalized or as agreed (4)	(3)	27 J
-65°C	2,25% nickel steel. Normalized, normalized and tempered or quenched and tempered (4)	-70°C	34 J
-90°C	3,5% nickel steel. Normalized, normalized and tempered or quenched and tempered (4)	-95°C	34 J
-165°C	9,0% nickel steel (5). Double normalized and tempered or quenched and tempered	-196°C	41 J
	Austenitic steels, such as types 304, 304L, 316, 316L, 321 and 347. Solution treated (6)	-196°C	41 J
	Aluminium alloys, such as type 5083 annealed	Not required	

TENSILE AND TOUGHNESS (IMPACT) TEST REQUIREMENTS	
Sampling frequency	<ul style="list-style-type: none"> Each "batch" to be tested
Toughness (Charpy V-notch test)	<ul style="list-style-type: none"> Impact test: longitudinal test pieces
<p>(1) The requirements for design temperatures below -165°C shall be specially agreed with the Society.</p> <p>(2) The chemical composition limits shall be in accordance with recognized standards.</p> <p>(3) The test temperature shall be 5°C below the design temperature or -20°C, whichever is lower.</p> <p>(4) A lower design temperature may be specially agreed with the Society for quenched and tempered materials.</p> <p>(5) This chemical composition is not suitable for castings.</p> <p>(6) The impact test of austenitic stainless steel is required only for service temperature less than -105°C.</p> <p>Note 1: The use of longitudinally or spirally welded pipes shall be specially approved by the Society.</p> <p>Note 2: The requirements for forgings and castings may be subject to special consideration by the Society.</p>	

Table 6 : Plates and sections for hull structures required by Ch 9, Sec 4, [6.2.2] and Ch 9, Sec 4, [6.2.3]

Minimum design temperature of hull structure	Maximum thickness (mm) for steel grades							
	A	B	D	E	AH	DH	EH	FH
0°C and above (1)	Recognized standards							
-5°C and above (2)	Recognized standards							
down to -5°C	15	25	30	50	25	45	50	50
down to -10°C	x	20	25	50	20	40	50	50
down to -20°C	x	x	20	50	x	30	50	50
down to -30°C	x	x	x	40	x	20	40	50
below -30°C	In accordance with Tab 3, except that the thickness limitation given in Tab 3 and in footnote (4) of that Table does not apply.							
<p>(1) For the purpose of Ch 9, Sec 4, [6.2.3]</p> <p>(2) For the purpose of Ch 9, Sec 4, [6.2.2].</p> <p>Note 1:</p> <p>x : Steel grade not to be used.</p>								

5 Welding of metallic materials and non-destructive testing

5.1 General

5.1.1 This Article shall apply to primary and secondary barriers only, including the inner hull where this forms the secondary barrier. Acceptance testing is specified for carbon, carbon-manganese, nickel alloy and stainless steels, but these tests may be adapted for other materials. At the discretion of the Society, impact testing of stainless steel and aluminium alloy weldments may be omitted and other tests may be specially required for any material.

Note 1: This requirement is also applicable for austenitic steels and aluminium alloy.

5.2 Welding consumables

5.2.1 Consumables intended for welding of cargo tanks shall be in accordance with recognized standards. Deposited weld metal tests and butt weld tests shall be required for all consumables. The results obtained from tensile and Charpy V-notch impact tests shall be in accordance with recognized standards. The chemical composition of the deposited weld metal shall be recorded for information.

The content of this requirement is also to cover process pressure vessels and secondary barriers.

5.3 Welding procedure tests for cargo tanks and process pressure vessels

5.3.1 Welding procedure tests for cargo tanks and process pressure vessels are required for all butt welds.

5.3.2 The test assemblies shall be representative of:

- each base material
- each type of consumable and welding process, and
- each welding position.

5.3.3 For butt welds in plates, the test assemblies shall be so prepared that the rolling direction is parallel to the direction of welding. The range of thickness qualified by each welding procedure test shall be in accordance with recognized standards. Radiographic or ultrasonic testing may be performed at the option of the fabricator.

5.3.4 The following welding procedure tests for cargo tanks and process pressure vessels shall be carried out in accordance with Article [3], with specimens made from each test assembly:

- cross-weld tensile tests
- longitudinal all-weld testing, where required by the recognized standards
- transverse bend tests, which may be face, root or side bends. However, longitudinal bend tests may be required in lieu of transverse bend tests in cases where the base material and weld metal have different strength levels
- one set of three Charpy V-notch impacts, generally at each of the following locations, as shown in Fig 2:
 - centreline of the weld
 - fusion line
 - 1 mm from the fusion line
 - 3 mm from the fusion line, and
 - 5 mm from the fusion line, and
- macrosection, microsection and hardness survey may also be required.

5.3.5 Each test shall satisfy the following requirements:

- tensile tests: cross-weld tensile strength shall not be less than the specified minimum tensile strength for the appropriate parent materials. For aluminium alloys, reference shall be made to Ch 9, Sec 4, [4.5.1], item c) with regard to the requirements for weld metal strength of under-matched welds (where the weld metal has a lower tensile strength than the parent metal). In every case, the position of fracture shall be recorded for information
- bend tests: no fracture is acceptable after a 180° bend over a former of a diameter four times the thickness of the test pieces, and

As an alternative to the bend test indicated, a test over a mandrel having a diameter equal to 3 times the thickness with a bend angle up to 120° may be required.

- Charpy V-notch impact tests: Charpy V-notch tests shall be conducted at the temperature prescribed for the base material being joined. The results of weld metal impact tests, minimum average energy (KV), shall be no less than 27 J. The weld metal requirements for subsize specimens and single energy values shall be in accordance with [3.2]. The results of fusion line and heat-affected zone impact tests shall show a minimum average energy (KV) in accordance with the transverse or longitudinal requirements of the base material, whichever is applicable, and for subsize specimens, the minimum average energy (KV) shall be in accordance with [3.2]. If the material thickness does not permit machining either full-size or standard subsize specimens, the testing procedure and acceptance standards shall be in accordance with recognized standards.

5.3.6 Procedure tests for fillet welding shall be in accordance with recognized standards. In such cases, consumables shall be so selected that exhibit satisfactory impact properties.

5.4 Welding procedure tests for piping

5.4.1 Welding procedure tests for piping shall be carried out and shall be similar to those detailed for cargo tanks in [5.3].

5.5 Production weld tests

5.5.1 For all cargo tanks and process pressure vessels, except integral and membrane tanks, production weld tests shall generally be performed for approximately each 50 m of butt-weld joints and shall be representative of each welding position. For secondary barriers, the same type production tests as required for primary tanks shall be performed, except that the number of tests may be reduced subject to agreement with the Society. Tests, other than those specified in [5.5.2] to [5.5.5] may be required for cargo tanks or secondary barriers.

5.5.2 The production tests for type A and type B independent tanks and semi-membrane tanks shall include bend tests and, where required for procedure tests, one set of three Charpy V-notch tests. The tests shall be made for each 50 m of weld. The Charpy V-notch tests shall be made with specimens having the notch alternately located in the centre of the weld and in the heat-affected zone (most critical location based on procedure qualification results). For austenitic stainless steel, all notches shall be in the centre of the weld.

5.5.3 For type C independent tanks and process pressure vessels, transverse weld tensile tests are required in addition to the tests listed in [5.5.2]. Tensile tests shall meet the requirements of [5.3.5].

5.5.4 The quality assurance/quality control programme shall ensure the continued conformity of the production welds as defined in the material manufacturers quality manual.

5.5.5 The test requirements for integral and membrane tanks are the same as the applicable test requirements listed in [5.3].

5.6 Non-destructive testing

5.6.1 The following provisions apply to independent tanks:

- a) Tracing, cutting and shaping are to be carried out so as to prevent, at the surface of the pieces, the production of defects detrimental to their use. In particular, marking the plates by punching and starting welding arcs outside the welding zone are to be avoided.
- b) Before welding, the edges to be welded are to be carefully examined, with possible use of non-destructive examination, in particular when chamfers are carried out.
- c) In all cases, the working units are to be efficiently protected against bad weather.
- d) The execution of provisional welds, where any, is to be subjected to the same requirements as the constructional welds. After elimination of the fillets, the area is to be carefully ground and inspected (the inspection is to include, if necessary, a penetrant fluid test).
- e) All welding consumables are subject to agreement. Welders are also to be agreed.

5.6.2 All test procedures and acceptance standards shall be in accordance with recognized standards, unless the designer specifies a higher standard in order to meet design assumptions. Radiographic testing shall be used, in principle, to detect internal defects. However, an approved ultrasonic test procedure in lieu of radiographic testing may be conducted, but, in addition, supplementary radiographic testing at selected locations shall be carried out to verify the results. Radiographic and ultrasonic testing records shall be retained.

5.6.3 For type A independent tanks and semi-membrane tanks, where the design temperature is below -20°C , and for type B independent tanks, regardless of temperature, all full penetration butt welds of the shell plating of cargo tanks shall be subjected to non-destructive testing suitable to detect internal defects over their full length. Ultrasonic testing in lieu of radiographic testing may be carried out under the same conditions as described in [5.6.2].

5.6.4 Where the design temperature is higher than -20°C , all full penetration butt welds in way of intersections and at least 10% of the remaining full penetration welds of tank structures shall be subjected to radiographic testing or ultrasonic testing under the same conditions as described in [5.6.2].

5.6.5 In each case, the remaining tank structure, including the welding of stiffeners and other fittings and attachments, shall be examined by magnetic particle or dye penetrant methods, as considered necessary.

5.6.6 For type C independent tanks, the extent of non-destructive testing shall be total or partial according to recognized standards, but the controls to be carried out shall not be less than the following:

- a) Total non-destructive testing referred to in Ch 9, Sec 4, [10.2]:
 - Radiographic testing:
 - all butt welds over their full length

- *Non-destructive testing for surface crack detection:*
 - *all welds over 10% of their length*
 - *reinforcement rings around holes, nozzles, etc., over their full length.*

As an alternative, ultrasonic testing as described in [5.6.2] may be accepted as a partial substitute for the radiographic testing. In addition, the Society may require total ultrasonic testing on welding of reinforcement rings around holes, nozzles, etc.

b) *Partial non-destructive testing referred to in Ch 9, Sec 4, [10.2]:*

- *Radiographic testing:*
 - *all butt-welded crossing joints and at least 10% of the full length of butt welds at selected positions uniformly distributed*
- *Non-destructive testing for surface crack detection:*
 - *reinforcement rings around holes, nozzles, etc., over their full length*
- *Ultrasonic testing:*
 - *as may be required by the Society in each instance.*

5.6.7 *The quality assurance/quality control programme shall ensure the continued conformity of the non-destructive testing of welds, as defined in the material manufacturer's quality manual.*

5.6.8 *Inspection of piping shall be carried out in accordance with the requirements of Ch 9, Sec 5.*

5.6.9 *The secondary barrier shall be non-destructive tested for internal defects as considered necessary. Where the outer shell of the hull is part of the secondary barrier, all sheer strake butts and the intersections of all butts and seams in the side shell shall be tested by radiographic testing.*

6 Other requirements for construction in metallic materials

6.1 General

6.1.1 *Inspection and non-destructive testing of welds shall be in accordance with the requirements of [5.5] and [5.6]. Where higher standards or tolerances are assumed in the design, they shall also be satisfied.*

6.2 Independent tank

6.2.1 *For type C tanks and type B tanks primarily constructed of bodies of revolution, the tolerances relating to manufacture, such as out-of-roundness, local deviations from the true form, welded joints alignment and tapering of plates having different thicknesses, shall comply with recognized standards. The tolerances shall also be related to the buckling analysis referred to in Ch 9, Sec 4, [9.3], item b) and Ch 9, Sec 4, [10.3], item b).*

6.2.2 *For type C tanks of carbon and carbon-manganese steel, post-weld heat treatment shall be performed after welding, if the design temperature is below -10°C . Post-weld heat treatment in all other cases and for materials other than those mentioned above shall be to recognized standards. The soaking temperature and holding time shall be to the recognized standards.*

6.2.3 *In the case of type C tanks and large cargo pressure vessels of carbon or carbon-manganese steel, for which it is difficult to perform the heat treatment, mechanical stress relieving by pressurizing may be carried out as an alternative to the heat treatment and subject to the following conditions:*

- *complicated welded pressure vessel parts such as sumps or domes with nozzles, with adjacent shell plates shall be heat treated before they are welded to larger parts of the pressure vessel*
- *the mechanical stress relieving process shall preferably be carried out during the hydrostatic pressure test required by Ch 9, Sec 4, [10.6], by applying a higher pressure than the test pressure required by Ch 9, Sec 4, [10.6], item a). The pressurizing medium shall be water*
- *for the water temperature, Ch 9, Sec 4, [10.6], item b) applies*
- *stress relieving shall be performed while the tank is supported by its regular saddles or supporting structure or, when stress relieving cannot be carried out on board, in a manner which will give the same stresses and stress distribution as when supported by its regular saddles or supporting structure*
- *the maximum stress relieving pressure shall be held for 2 h per 25 mm of thickness, but in no case less than 2 h*

- the upper limits placed on the calculated stress levels during stress relieving shall be the following:
 - equivalent general primary membrane stress: $0,9 R_e$
 - equivalent stress composed of primary bending stress plus membrane stress: $1,35 R_e$, where R_e is the specific lower minimum yield stress or 0,2% proof stress at test temperature of the steel used for the tank
- strain measurements will normally be required to prove these limits for at least the first tank of a series of identical tanks built consecutively. The location of strain gauges shall be included in the mechanical stress relieving procedure to be submitted in accordance with [6.2.3]
- the test procedure shall demonstrate that a linear relationship between pressure and strain is achieved at the end of the stress relieving process when the pressure is raised again up to the design pressure
- high-stress areas in way of geometrical discontinuities such as nozzles and other openings shall be checked for cracks by dye penetrant or magnetic particle inspection after mechanical stress relieving. Particular attention in this respect shall be paid to plates exceeding 30 mm in thickness
- steels which have a ratio of yield stress to ultimate tensile strength greater than 0,8 shall generally not be mechanically stress relieved. If, however, the yield stress is raised by a method giving high ductility of the steel, slightly higher rates may be accepted upon consideration in each case
- mechanical stress relieving cannot be substituted for heat treatment of cold formed parts of tanks, if the degree of cold forming exceeds the limit above which heat treatment is required
- the thickness of the shell and heads of the tank shall not exceed 40 mm. Higher thicknesses may be accepted for parts which are thermally stress relieved
- local buckling shall be guarded against, particularly when tori-spherical heads are used for tanks and domes, and
- the procedure for mechanical stress relieving shall be to a recognized standard.

6.3 Secondary barriers

6.3.1 During construction, the requirements for testing and inspection of secondary barriers shall be approved or accepted by the Society (see Ch 9, Sec 4, [2.4.3], item e) and Ch 9, Sec 4, [2.4.3], item f)).

6.4 Semi-membrane tanks

6.4.1 For semi-membrane tanks, the relevant requirements in Article [6] for independent tanks or for membrane tanks shall be applied as appropriate.

6.5 Membrane tanks

6.5.1 The quality assurance/quality control programme shall ensure the continued conformity of the weld procedure qualification, design details, materials, construction, inspection and production testing of components. These standards and procedures shall be developed during the prototype testing programme.

7 Non-metallic materials

7.1 General

7.1.1 The information in Appendix 4 of the IGC Code is given for guidance in the selection and use of these materials, based on the experience to date.

Section 7 Cargo Pressure / Temperature Control

1 Methods of control

1.1 General

1.1.1 With the exception of tanks designed to withstand full gauge vapour pressure of the cargo under conditions of the upper ambient design temperatures, cargo tanks' pressure and temperature shall be maintained at all times within their design range by either one, or a combination of, the following methods:

- reliquefaction of cargo vapours
- thermal oxidation of vapours
- pressure accumulation, and
- liquid cargo cooling.

1.1.2 For certain cargoes, where required by Ch 9, Sec 17, the cargo containment system shall be capable of withstanding the full vapour pressure of the cargo under conditions of the upper ambient design temperatures, irrespective of any system provided for dealing with boil-off gas.

1.1.3 Venting of the cargo to maintain cargo tank pressure and temperature shall not be acceptable except in emergency situations. The Society may permit certain cargoes to be controlled by venting cargo vapours to the atmosphere at sea. This may also be permitted in port with the authorization of the port Administration.

2 Design of systems

2.1 General

2.1.1 For normal service, the upper ambient design temperature shall be:

- sea: 32°C
- air: 45°C.

For service in particularly hot or cold zones, these design temperatures shall be increased or decreased, to the satisfaction of the Society. The overall capacity of the system shall be such that it can control the pressure within the design conditions without venting to atmosphere.

2.1.2 Any subcooling units and reliquefaction units installed on board are to be considered as essential service as per Pt C, Ch 2, Sec 1, [3.4.1].

2.1.3 Subject to special consideration by the Society and to Shipowner agreement, the requirement stated in [2.1.2] may be waived if justifications are provided to demonstrate that these systems are not essential for the boil-off gas management.

3 Reliquefaction of cargo vapours

3.1

3.1.1 In general, in addition to the requirements of this Article, the specific requirements stated in Part C and Part D, Chapter 9 of the Rules for various machinery and equipment are also applicable to refrigerating installation components.

3.1.2 Attention is drawn to the requirements of Ch 9, Sec 1, [6.2.4] regarding the satisfactory operation of the reliquefaction plant, if installed, and of any other equipment fitted for the burning of cargo vapours, that is to be ascertained during the first full loading and the subsequent first unloading of ships carrying liquefied natural gasses (LNG) in bulk.

3.1.3 General

The reliquefaction system may be arranged in one of the following ways:

- a) a direct system, where evaporated cargo is compressed, condensed and returned to the cargo tanks
- b) an indirect system, where cargo or evaporated cargo is cooled or condensed by refrigerant without being compressed
- c) a combined system, where evaporated cargo is compressed and condensed in a cargo/refrigerant heat exchanger and returned to the cargo tanks, and
- d) if the reliquefaction system produces a waste stream containing methane during pressure control operations within the design conditions, these waste gases, as far as reasonably practicable, are disposed of without venting to atmosphere.

Note 1: The requirements of Ch 9, Sec 17 and Ch 9, Sec 19 may preclude the use of one or more of these systems or may specify the use of a particular system.

3.1.4 Compatibility

Refrigerants used for reliquefaction shall be compatible with the cargo they may come into contact with. In addition, when several refrigerants are used and may come into contact, they shall be compatible with each other.

3.2 Refrigerating installation components

3.2.1 Pressure vessels and heat exchangers

- a) Pressure vessels of refrigerating plants are to comply with the relevant requirements of Pt C, Ch 1, Sec 3 and Ch 9, Sec 5.
- b) Notch toughness of steels used in low temperature plants is to be suitable for the thickness and the lowest design temperature. A check of the notch toughness properties may be required where the working temperature is below minus 40°C.

3.2.2 Piping systems

- a) Refrigerant pipes are generally to be regarded as pressure pipes.
- b) Refrigerant pipes are to be considered as belonging to the following classes:
 - class I: where they are intended for ammonia or toxic and flammable substances
 - class II: for other refrigerants
- c) In general, the pipes conveying the cooling medium are not to come into direct contact with the ship's structure; they are to be carefully insulated on their run outside the refrigerated spaces, and more particularly when passing through bulkheads and decks.
- d) The materials used for the pipes are to be appropriate to the fluids that they convey. Copper, brass, bronze and other copper alloys are not to be used for pipes likely to convey ammonia. Methods proposed for joining such pipes are to be submitted to the Society for consideration.
- e) Notch toughness of the steels used is to be suitable for the application concerned.
- f) Where necessary, cooling medium pipes within refrigerated spaces or embedded in insulation are to be externally protected against corrosion; for steel pipes, this protection is to be ensured by galvanisation or equivalent. All useful precautions are to be taken to protect the joints of such pipes against corrosion.

3.3 Refrigerants

3.3.1 Prohibited refrigerants

The use of the following refrigerants is not allowed for shipboard installations:

- Methyl chloride
- R11 - Trichloromonofluoromethane (C Cl₃ F)

3.3.2 Statutory requirements

Particular attention is to be paid to any limitation on the use of refrigerants imposed by the Administration of the State whose flag the ship is flying.

4 Thermal oxidation of vapours

4.1 General

4.1.1 Article [8] states that unless an alternative means of controlling the cargo pressure/temperature is provided to the satisfaction of the Society, a standby unit (or units) affording spare capacity at least equal to the largest required single unit is (are) to be fitted.

For the purpose of complying with the above, a suitable alternative means of pressure/temperature control would be:

- a) auxiliary boiler(s) capable of burning the boil-off vapours and disposing of the generated steam or an alternative waste heat system acceptable to the Society. Consideration will be given to systems burning only part of the boil-off vapour if it can be shown that MARVS will not be reached within a period of 21 days.
- b) controlled venting of cargo vapours as specified in [1.1.3] if permitted by the Administration concerned.

4.1.2 *Maintaining the cargo tank pressure and temperature by means of thermal oxidation of cargo vapours, as defined in Ch 9, Sec 1, [4.1.50] and Ch 9, Sec 16, [2] shall be permitted only for LNG cargoes. In general:*

- *thermal oxidation systems shall exhibit no externally visible flame and shall maintain the uptake exhaust temperature below 535°C*
- *arrangement of spaces where oxidation systems are located shall comply with Ch 9, Sec 16, [3] and supply systems shall comply with Ch 9, Sec 16, [4], and*
- *if waste gases coming from any other system are to be burnt, the oxidation system shall be designed to accommodate all anticipated feed gas compositions.*

4.2 Thermal oxidation systems

4.2.1 Thermal oxidation systems shall comply with the following:

- each thermal oxidation system shall have a separate uptake
- each thermal oxidation system shall have a dedicated forced draught system, and
- combustion chambers and uptakes of thermal oxidation systems shall be designed to prevent any accumulation of gas.

4.2.2 Gas combustion units are to comply with the provisions of Pt C, Ch 1, Sec 3, [7].

4.3 Burners

4.3.1 Burners shall be designed to maintain stable combustion under all design firing conditions.

4.4 Safety

4.4.1 Suitable devices shall be installed and arranged to ensure that gas flow to the burner is cut off unless satisfactory ignition has been established and maintained.

4.4.2 Each oxidation system shall have provision to manually isolate its gas fuel supply from a safely accessible position.

4.4.3 Provision shall be made for automatic purging the gas supply piping to the burners by means of an inert gas, after the extinguishing of these burners.

4.4.4 In case of flame failure of all operating burners for gas or oil or for a combination thereof, the combustion chambers of the oxidation system shall be automatically purged before relighting.

4.4.5 Arrangements shall be made to enable the combustion chamber to be manually purged.

5 Pressure accumulation systems

5.1 General

5.1.1 The containment system insulation, design pressure or both shall be adequate to provide for a suitable margin for the operating time and temperatures involved. No additional pressure and temperature control system is required. Conditions for acceptance shall be recorded in the International Certificate of Fitness for the Carriage of Liquefied Gases in Bulk.

Note 1: The operating time corresponds to a period not less than 21 days.

6 Liquid cargo cooling

6.1 General

6.1.1 The bulk cargo liquid may be refrigerated by coolant circulated through coils fitted either inside the cargo tank or onto the external surface of the cargo tank.

7 Segregation

7.1 General

7.1.1 Where two or more cargoes that may react chemically in a dangerous manner are carried simultaneously, separate systems as defined in Ch 9, Sec 1, [4.1.45], each complying with availability criteria as specified in [8], shall be provided for each cargo. For simultaneous carriage of two or more cargoes that are not reactive to each other but where, due to properties of their vapour, separate systems are necessary, separation may be by means of isolation valves.

8 Availability

8.1 General

8.1.1 The availability of the system and its supporting auxiliary services shall be such that:

- a) in case of a single failure of a mechanical non-static component or a component of the control systems, the cargo tanks' pressure and temperature can be maintained within their design range without affecting other essential services

Note 1: "mechanical non-static component" refers to pumps, fan or compressors.

Note 2: "component of the control systems" refers to electronical cards.

- b) redundant piping systems are not required

- c) *heat exchangers that are solely necessary for maintaining the pressure and temperature of the cargo tanks within their design ranges shall have a standby heat exchanger, unless they have a capacity in excess of 25% of the largest required capacity for pressure control and they can be repaired on board without external resources. Where an additional and separate method of cargo tank pressure and temperature control is fitted that is not reliant on the sole heat exchanger, then a standby heat exchanger is not required.*

A single heat exchanger without margin (i.e. designed for 100% capacity) may also be not duplicated if another means of pressure/temperature control is provided with a capacity that is at least equivalent to the missing 25% capacity for the heat exchanger, and

- d) *for any cargo heating or cooling medium, provisions shall be made to detect the leakage of toxic or flammable vapours into an otherwise safe location or overboard in accordance with Ch 9, Sec 13, [6]. Any vent outlet from this leak detection arrangement shall be to a safe location and be fitted with a flame screen.*

Any non-static component (e.g. pump, compressor, fan) is to be duplicated in such a way that a single failure of one of these components will not impair the performance of the pressure/temperature control system. Static components such as piping or heat exchanger are not necessarily to be duplicated: no redundancy is required for piping and heat exchangers having an operational margin (+25% capacity).

Section 8 Vent Systems for Cargo Containment

1 General

1.1

1.1.1 All cargo tanks shall be provided with a pressure relief system appropriate to the design of the cargo containment system and the cargo being carried. Hold spaces and interbarrier spaces, which may be subject to pressures beyond their design capabilities, shall also be provided with a suitable pressure relief system. Pressure control systems specified in Ch 9, Sec 7 shall be independent of the pressure relief systems.

2 Pressure relief systems

2.1 General

2.1.1 Cargo tanks, including deck tanks, shall be fitted with a minimum of two pressure relief valves (PRVs), each being of equal size within manufacturer's tolerances and suitably designed and constructed for the prescribed service.

2.1.2 Interbarrier spaces shall be provided with pressure relief devices.

For membrane systems, the designer shall demonstrate adequate sizing of interbarrier space PRVs.

2.1.3 Protection of interbarrier spaces

- The relieving capacity of pressure relief devices of interbarrier spaces surrounding independent type B cargo tanks may be determined on the basis of the method given in Article [2]; however, the leakage rate is to be determined in accordance with Ch 9, Sec 4, [2.5.2].
- The relieving capacity of pressure relief devices for interbarrier spaces of membrane and semi-membrane tanks is to be evaluated on the basis of specific membrane/semi-membrane tank design.
- The relieving capacity of pressure relief devices for interbarrier spaces adjacent to integral type cargo tanks may, if applicable, be determined as for type A independent cargo tanks.

2.1.4 Size of pressure relief devices

The combined relieving capacity, in m³/s, of the pressure relief devices for interbarrier spaces surrounding type A independent cargo tanks where the insulation is fitted to the cargo tanks may be determined by the following formula:

$$Q_{sa} = 3,4 \cdot A_C \cdot \frac{\rho}{\rho_v} \cdot \sqrt{h}$$

where:

Q_{sa} : Minimum required discharge rate of air in standard conditions of 273 K and 1,013 bar

A_C : Design crack opening area, in m², equal to:

$$A_C = \frac{\pi}{4} \cdot \delta \cdot l$$

where:

δ : Maximum crack opening width, in m, equal to:

$$\delta = 0,2 t$$

t being the thickness of tank bottom plating, in m

l : Design crack length, in m, equal to the diagonal of the largest plate panel of the tank bottom (see Fig 1)

h : Maximum liquid height above tank bottom plus 10 × MARVS, in m

ρ : Density of product liquid phase, in kN/m³, at the set pressure of the interbarrier space relief device

ρ_v : Density of product vapour phase, in kN/m³, at the set pressure of the interbarrier space relief device and a temperature of 273 K.

2.1.5 The setting of the PRVs shall not be higher than the vapour pressure that has been used in the design of the tank. Where two or more PRVs are fitted, valves comprising not more than 50% of the total relieving capacity may be set at a pressure up to 5% above MARVS to allow sequential lifting, minimizing unnecessary release of vapour.

Figure 1 : Determination of I

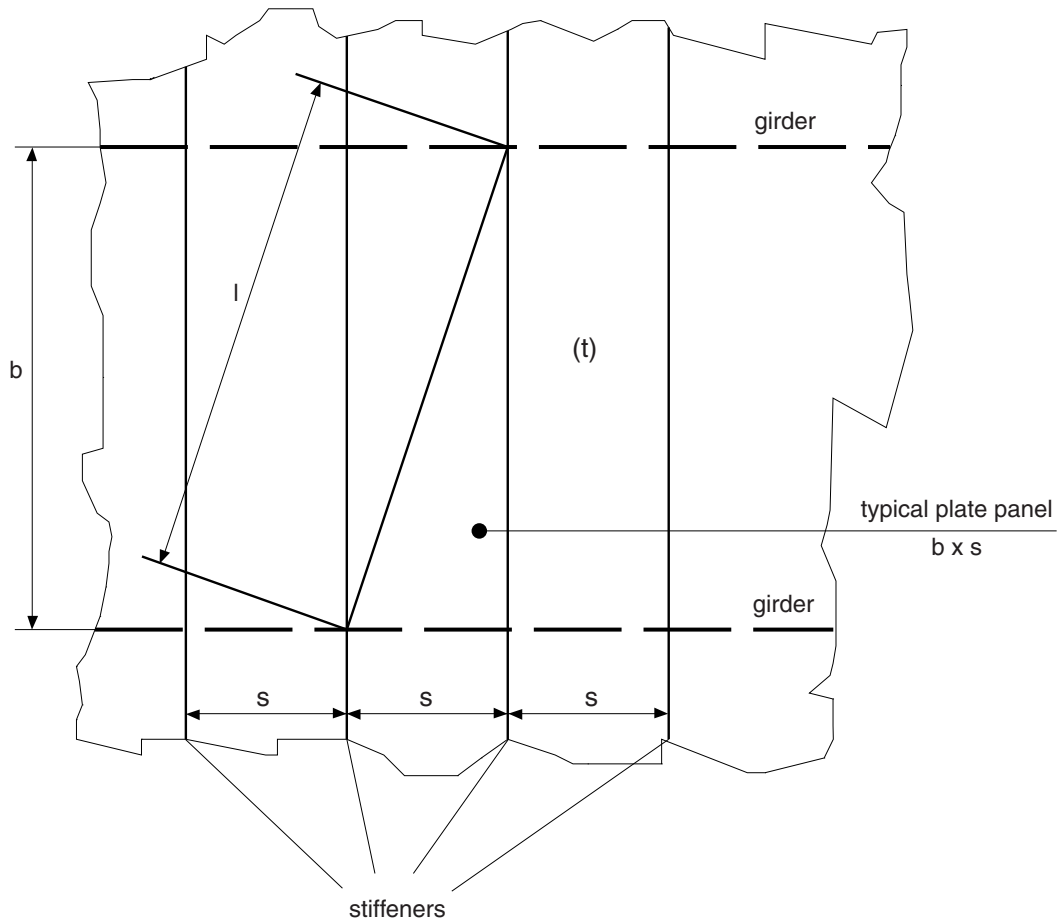

2.1.6 The following temperature requirements apply to PRVs fitted to pressure relief systems:

- PRVs on cargo tanks with a design temperature below 0°C shall be designed and arranged to prevent their becoming inoperative due to ice formation
- the effects of ice formation due to ambient temperatures shall be considered in the construction and arrangement of PRVs
- PRVs shall be constructed of materials with a melting point above 925°C. Lower melting point materials for internal parts and seals may be accepted, provided that fail-safe operation of the PRV is not compromised, and
- sensing and exhaust lines on pilot operated relief valves shall be of suitably robust construction to prevent damage.

2.1.7 Valve testing

a) PRVs shall be type-tested. Type tests shall include:

- verification of relieving capacity
- cryogenic testing when operating at design temperatures colder than -55°C
- seat tightness testing, and
- pressure containing parts are pressure tested to at least 1,5 times the design pressure.

PRVs shall be tested in accordance with recognized standards.

Note 1: ISO 21013-1:2008 - Cryogenic vessels - Pressure-relief accessories for cryogenic service - part 1: Recloseable pressure-relief valves; and ISO 4126-1; 2004 Safety devices for protection against excessive pressure - part 1 and part 4: Safety valves.

b) Each PRV shall be tested to ensure that:

- it opens at the prescribed pressure setting, with an allowance not exceeding $\pm 10\%$ for 0 to 0,15 MPa, $\pm 6\%$ for 0,15 to 0,30 MPa, $\pm 3\%$ for 0,30 MPa and above
- seat tightness is acceptable, and
- pressure containing parts will withstand at least 1,5 times the design pressure.

2.1.8 PRVs shall be set and sealed by the Society, and a record of this action, including the valves' set pressure, shall be retained on board the ship.

2.1.9 Cargo tanks may be permitted to have more than one relief valve set pressure in the following cases:

- installing two or more properly set and sealed PRVs and providing means, as necessary, for isolating the valves not in use from the cargo tank, or
- installing relief valves whose settings may be changed by the use of a previously approved device not requiring pressure testing to verify the new set pressure. All other valve adjustments shall be sealed.

2.1.10 Changing the set pressure under the provisions of [2.1.9] and the corresponding resetting of the alarms referred to in Ch 9, Sec 13, [4.1.2] shall be carried out under the supervision of the Master in accordance with approved procedures and as specified in the ship's operating manual. Changes in set pressure shall be recorded in the ship's log and a sign shall be posted in the cargo control room, if provided, and at each relief valve, stating the set pressure.

2.1.11 In the event of a failure of a cargo tank-installed PRV, a safe means of emergency isolation shall be available:

- a) Procedures shall be provided and included in the cargo operations manual (see IGC Code 18.2).
- b) The procedures shall allow only one of the cargo tank installed PRVs to be isolated.

Note 1: The basic principle is to ensure a safe isolation before removing the PRV for maintenance. The use of balloons can be a solution and accepted in principle, but their efficiency (tightness) shall be demonstrated. A procedure to reinstall or change the balloon after use shall also be prepared. For systems where the outlets of several PRVs are connected to a common vent header, safe isolation means, where balloons are used, one balloon at the inlet of the PRV and one at the outlet.

- c) Isolation of the PRV shall be carried out under the supervision of the Master. This action shall be recorded in the ship's log and a sign posted in the cargo control room, if provided, and at the PRV.
- d) The tank shall not be loaded until the full relieving capacity is restored.

2.1.12 Each PRV installed on a cargo tank shall be connected to a venting system, which shall be:

- so constructed that the discharge will be unimpeded and directed vertically upwards at the exit
- arranged to minimize the possibility of water or snow entering the vent system
- arranged such that the height of vent exits shall not be less than $B/3$ or 6 m, whichever is the greater, above the weather deck, and
- 6 m above working areas and walkways.

2.1.13 The height of vent exits as indicated in [2.1.12] is also to be measured above storage tanks and cargo liquid lines, where applicable.

2.1.14 Cargo PRV vent exits shall be arranged at a distance at least equal to B or 25 m, whichever is less, from the nearest air intake, outlet or opening to accommodation spaces, service spaces and control stations, or other non-hazardous areas.

For ships less than 90 m in length, smaller distances may be permitted.

All other vent outlets connected to the cargo containment system shall be arranged at a distance of at least 10 m, measured horizontally, from the nearest air intake, outlet or opening to accommodation spaces, service spaces and control stations, or other non-hazardous areas.

In the case of carriage of flammable and/or toxic products, the vent exits are to be arranged at a distance of at least 5 m, measured horizontally, from exhaust ducts and at least 10 m, measured horizontally, from intake ducts serving cargo pump rooms and/or cargo compressor rooms.

2.1.15 All other cargo vent outlets not dealt with in other chapters shall be arranged in accordance with [2.1.12] and [2.1.12], items a) and b). Means shall be provided to prevent liquid overflow from vent mast outlets, due to hydrostatic pressure from spaces to which they are connected.

Note 1: The meaning of this recommendation is to avoid the presence of liquid in the vent mast and in the pipes so that there was no overflow from vent mast outlets, the designer has to demonstrated that liquid will never reach the outlet of the vent mast in case of any single failure. For example install a knockout drum is acceptable.

2.1.16 If cargoes that react in a dangerous manner with each other are carried simultaneously, a separate pressure relief system shall be fitted for each one.

2.1.17 In the vent piping system, means for draining liquid from places where it may accumulate shall be provided. The PRVs and piping shall be arranged so that liquid can, under no circumstances, accumulate in or near the PRVs.

Note 1: The words 'draining liquid' means, in this paragraph water, and/or snow.

2.1.18 Suitable protection screens of not more than 13 mm square mesh shall be fitted on vent outlets to prevent the ingress of extraneous objects without adversely affecting the flow. Other requirements for protection screens apply when carrying specific cargoes (see Ch 9, Sec 17, [9] and Ch 9, Sec 17, [21]).

2.1.19 All vent piping shall be designed and arranged not to be damaged by the temperature variations to which it may be exposed, forces due to flow or the ship's motions.

2.1.20 PRVs shall be connected to the highest part of the cargo tank above deck level. PRVs shall be positioned on the cargo tank so that they will remain in the vapour phase at the filling limit (FL) as defined in Ch 9, Sec 15, under conditions of 15° list and 0,015 L trim, where L is defined in Ch 9, Sec 1, [4.1.31].

2.1.21 The adequacy of the vent system fitted on tanks loaded in accordance with Ch 9, Sec 15, [1.5.2] shall be demonstrated, taking into account IMO resolution A.829(19)). A relevant certificate shall be permanently kept on board the ship. For the purposes of this paragraph, vent system means:

- the tank outlet and the piping to the PRV
- the PRV, and
- the piping from the PRVs to the location of discharge to the atmosphere, including any interconnections and piping that joins other tanks.

3 Vacuum protection systems

3.1 General

3.1.1 Cargo tanks not designed to withstand a maximum external pressure differential 0,025 MPa, or tanks that cannot withstand the maximum external pressure differential that can be attained at maximum discharge rates with no vapour return into the cargo tanks, or by operation of a cargo refrigeration system, or by thermal oxidation, shall be fitted with:

- a) two independent pressure switches to sequentially alarm and subsequently stop all suction of cargo liquid or vapour from the cargo tank and refrigeration equipment, if fitted, by suitable means at a pressure sufficiently below the maximum external designed pressure differential of the cargo tank, or
- b) vacuum relief valves with a gas flow capacity at least equal to the maximum cargo discharge rate per cargo tank, set to open at a pressure sufficiently below the external design differential pressure of the cargo tank.

3.1.2 Subject to the requirements of Ch 9, Sec 17, the vacuum relief valves shall admit an inert gas, cargo vapour or air to the cargo tank and shall be arranged to minimize the possibility of the entrance of water or snow. If cargo vapour is admitted, it shall be from a source other than the cargo vapour lines.

3.1.3 The vacuum protection system shall be capable of being tested to ensure that it operates at the prescribed pressure.

4 Sizing of pressure relieving system

4.1 Sizing of pressure relief valves

4.1.1 PRVs shall have a combined relieving capacity for each cargo tank to discharge the greater of the following, with not more than a 20% rise in cargo tank pressure above the MARVS:

- a) The maximum capacity of the cargo tank inerting system, if the maximum attainable working pressure of the cargo tank inerting system exceeds the MARVS of the cargo tanks, or
- b) Vapours generated under fire exposure computed using the following formula:

$$Q = FGA^{0,82}$$

where:

Q : Minimum required rate of discharge, in m³/s, of air at standard conditions of 273,15 Kelvin (K) and 0,1013 MPa

F : Fire exposure factor for different cargo types as follows:

- 1,0 for tanks without insulation located on deck
- 0,5 for tanks above the deck, when insulation is approved by the Society. Approval will be based on the use of a fireproofing material, the thermal conductance of insulation and its stability under fire exposure
- 0,5 for uninsulated independent tanks installed in holds
- 0,2 for insulated independent tanks in holds (or uninsulated independent tanks in insulated holds)
- 0,1 for insulated independent tanks in inerted holds (or uninsulated independent tanks in inerted, insulated holds)
- 0,1 for membrane and semi-membrane tanks. For independent tanks partly protruding through the weather decks, the fire exposure factor shall be determined on the basis of the surface areas above and below deck

A : External surface area of the tank, in m², as defined in Ch 9, Sec 1, [4.1.15], for different tank types, as shown in Fig 2

Note 1: L_{min}, for non-tapered tanks, is the smaller of the horizontal dimensions of the flat bottom of the tank. For tapered tanks, as would be used for the forward tank, L_{min} is the smaller of the length and the average width.

- For prismatic tanks whose distance between the flat bottom of the tank and bottom of the hold space is equal to or less than L_{min}/10, A is to be taken equal to the external surface area minus flat bottom surface area
- For prismatic tanks whose distance between the flat bottom of the tank and bottom of the hold space is greater than L_{min}/10, A is to be taken equal to the external surface area.

G : Gas factor according to formula:

$$G = \frac{12,4}{LD} \sqrt{\frac{ZT}{M}}$$

with:

T : Temperature in degrees Kelvin at relieving conditions, i.e. 120% of the pressure at which the pressure relief valve is set

L : Latent heat of the material being vaporized at relieving conditions, in kJ/kg

D : A constant based on relation of specific heats and is calculated as follows:

$$D = \sqrt{k \left(\frac{2}{k+1} \right)^{\frac{k+1}{k-1}}}$$

k : Ratio of specific heats at relieving conditions, and the value of which is between 1,0 and 2,2. If *k* is not known, *D* = 0,606 shall be used

Z : Compressibility factor of the gas at relieving conditions. If not known, *Z* = 1 shall be used

M : Molecular mass of the product.

The gas factor of each cargo to be carried shall be determined and the highest value shall be used for PRV sizing.

The required mass flow of air at relieving conditions is given by the formula:

$$M_{air} = Q \rho_{air}$$

where:

ρ_{air} : Density of air, taken equal to 1,296 kg/m³ (air at 273,15 K and 0,1013 MPa).

4.2 Sizing of vent pipe system

4.2.1 Pressure losses upstream and downstream of the PRVs shall be taken into account when determining their size to ensure the flow capacity required by [4.1].

4.3 Upstream pressure losses

4.3.1 The pressure drop in the vent line from the tank to the PRV inlet shall not exceed 3% of the valve set pressure at the calculated flow rate, in accordance with [4.1].

4.3.2 Pilot-operated PRVs shall be unaffected by inlet pipe pressure losses when the pilot senses directly from the tank dome.

4.3.3 Pressure losses in remotely sensed pilot lines shall be considered for flowing type pilots.

4.4 Downstream pressure losses

4.4.1 Where common vent headers and vent masts are fitted, calculations shall include flow from all attached PRVs.

4.4.2 The built-up back pressure in the vent piping from the PRV outlet to the location of discharge to the atmosphere, and including any vent pipe interconnections that join other tanks, shall not exceed the following values:

- for unbalanced PRVs: 10% of MARVS
- for balanced PRVs: 30% of MARVS, and
- for pilot operated PRVs: 50% of MARVS.

Alternative values provided by the PRV manufacturer may be accepted.

4.5 Blow-down

4.5.1 To ensure stable PRV operation, the blow-down shall not be less than the sum of the inlet pressure loss and 0,02 MARVS at the rated capacity.

Figure 2 : External surface area of the tank

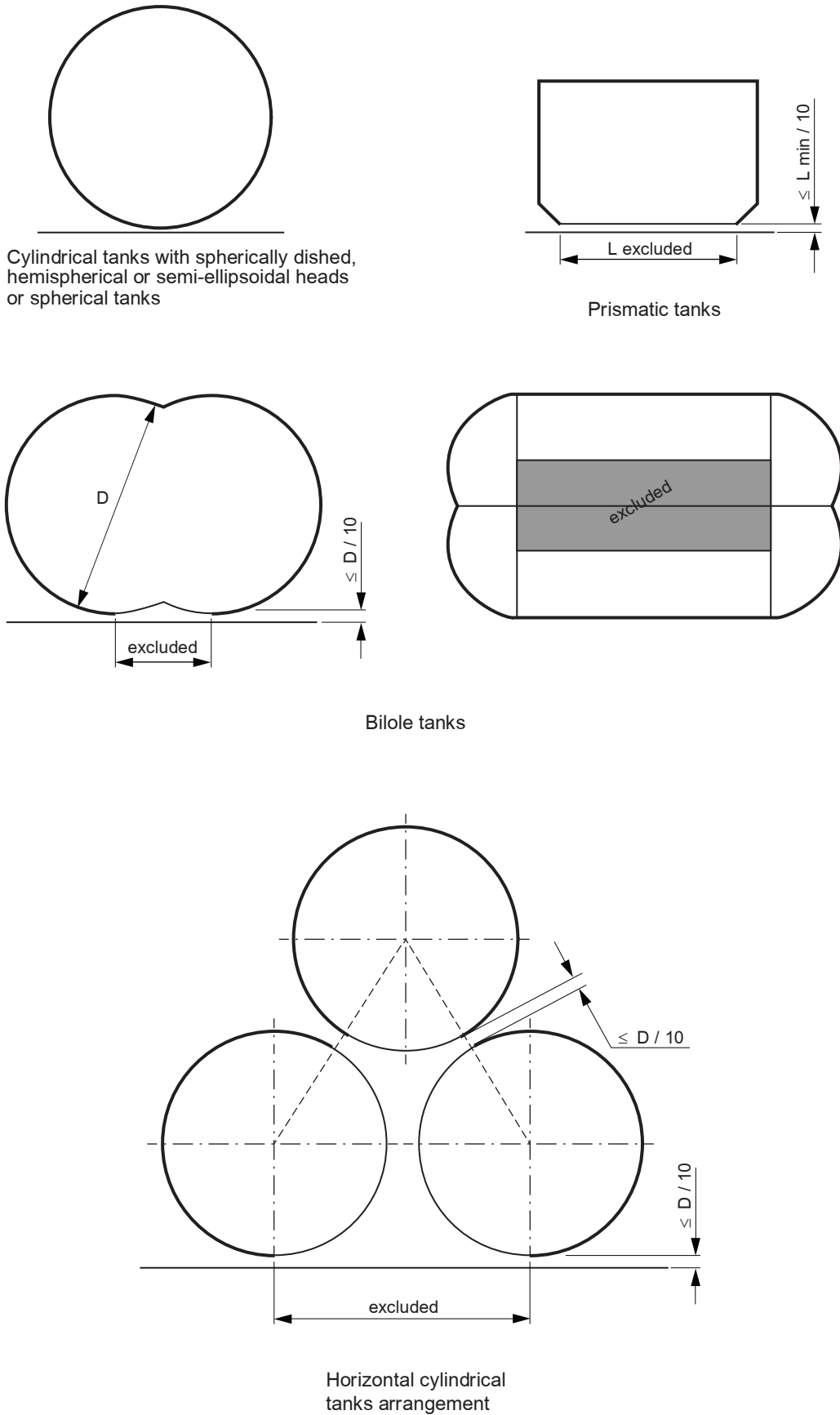

Section 9 Cargo Containment System Atmosphere Control

1 General

1.1 Atmosphere control within the cargo containment system

1.1.1 A piping system shall be arranged to enable each cargo tank to be safely gas-freed, and to be safely filled with cargo vapour from a gas-free condition. The system shall be arranged to minimize the possibility of pockets of gas or air remaining after changing the atmosphere.

1.1.2 For flammable cargoes, the system shall be designed to eliminate the possibility of a flammable mixture existing in the cargo tank during any part of the atmosphere change operation by utilizing an inerting medium as an intermediate step.

1.1.3 Piping systems that may contain flammable cargoes shall comply with [1.1.1] and [1.1.2].

1.1.4 A sufficient number of gas sampling points shall be provided for each cargo tank and cargo piping system to adequately monitor the progress of atmosphere change. Gas sampling connections shall be fitted with a single valve above the main deck, sealed with a suitable cap or blank (see Ch 9, Sec 5, [6.4.5]).

1.1.5 Inert gas utilized in these procedures may be provided from the shore or from the ship.

1.2 Atmosphere control within the hold spaces (cargo containment systems other than type C independent tanks)

1.2.1 Interbarrier and hold spaces associated with cargo containment systems for flammable gases requiring full or partial secondary barriers shall be inerted with a suitable dry inert gas and kept inerted with make-up gas provided by a shipboard inert gas generation system, or by shipboard storage, which shall be sufficient for normal consumption for at least 30 days.

1.2.2 Alternatively, subject to the restrictions specified in Ch 9, Sec 17, the spaces referred to in [1.2.1] requiring only a partial secondary barrier may be filled with dry air provided that the ship maintains a stored charge of inert gas or is fitted with an inert gas generation system sufficient to inert the largest of these spaces, and provided that the configuration of the spaces and the relevant vapour detection systems, together with the capability of the inerting arrangements, ensures that any leakage from the cargo tanks will be rapidly detected and inerting effected before a dangerous condition can develop. Equipment for the provision of sufficient dry air of suitable quality to satisfy the expected demand shall be provided.

1.2.3 For non-flammable gases, the spaces referred to in [1.2.1] and [1.2.2] may be maintained with a suitable dry air or inert atmosphere.

1.3 Environmental control of spaces surrounding type C independent tanks

1.3.1 Spaces surrounding cargo tanks that do not have secondary barriers shall be filled with suitable dry inert gas or dry air and be maintained in this condition with make-up inert gas provided by a shipboard inert gas generation system, shipboard storage of inert gas, or with dry air provided by suitable air drying equipment. If the cargo is carried at ambient temperature, the requirement for dry air or inert gas is not applicable.

1.3.2 As far as the requirements relevant to the dew point are concerned, the following additional provisions apply:

- a) Where cargo tank insulation is not protected from water vapour penetration by means of an effective vapour barrier, accepted by the Society, the maximum value of the dew point is to be less than the design temperature
- b) Where cargo tank insulation is protected by an effective vapour barrier, accepted by the Society, the maximum value of the dew point is to be less than the minimum temperature which may be found on any surface within the spaces filled with dry inert gas or dry air
- c) The temperature of the hull structures adjacent to cargo tanks is not to become lower than the minimum permissible working temperature, specified in Ch 9, Sec 6 for the steel grade employed for such hull structures
- d) The capacity of dry air or inert gas equipment to produce dry air is to be verified in workshop
- e) Means are to be provided on board to measure the dryness of the hold space atmosphere. The equipment may be portable provided permanent connections and/or sampling pipes are fitted.

1.4 Inerting

1.4.1 *Inerting refers to the process of providing a non-combustible environment. Inert gases shall be compatible chemically and operationally at all temperatures likely to occur within the spaces and the cargo. The dew points of the gases shall be taken into consideration.*

1.4.2 Precautions are to be taken to minimise the risk that static electricity generated by the inert gas system may become a source of ignition.

1.4.3 *Where inert gas is also stored for fire-fighting purposes, it shall be carried in separate containers and shall not be used for cargo services.*

1.4.4 *Where inert gas is stored at temperatures below 0°C, either as a liquid or as a vapour, the storage and supply system shall be designed so that the temperature of the ship's structure is not reduced below the limiting values imposed on it.*

1.4.5 *Arrangements to prevent the backflow of cargo vapour into the inert gas system that are suitable for the cargo carried, shall be provided. If such plants are located in machinery spaces or other spaces outside the cargo area, two non-return valves or equivalent devices and, in addition, a removable spool piece shall be fitted in the inert gas main in the cargo area. When not in use, the inert gas system shall be made separate from the cargo system in the cargo area except for connections to the hold spaces or interbarrier spaces.*

1.4.6 *The arrangements shall be such that each space being inerted can be isolated and the necessary controls and relief valves, etc., shall be provided for controlling pressure in these spaces.*

1.4.7 *Where insulation spaces are continually supplied with an inert gas as part of a leak detection system, means shall be provided to monitor the quantity of gas being supplied to individual spaces.*

1.5 Inert gas production on board

1.5.1 Attention is drawn to the requirements of Ch 9, Sec 1, [6.2.4] regarding the satisfactory operation of the inert gas generating plant and of the associated control system that is to be ascertained during the first full loading and the subsequent first unloading of ships carrying liquefied natural gasses (LNG) in bulk.

1.5.2

- a) Spaces associated with cargo containment adjacent to cargo tanks containing flammable products having a flashpoint equal to or less than 60°C are to be kept in an inert gas environment.
- b) Inert gas generating systems are to be considered as essential services and are to comply with the applicable Sections of the Rules, as far as applicable.
- c) Where, in addition to inert gas produced on board, it is possible to introduce dry air into the above mentioned spaces, where this is acceptable depending on the type of cargo tank adopted, or to introduce inert gas from a supply existing on board, it is not necessary that standby or spare components for the inert gas system are kept on board.

1.5.3 *The equipment shall be capable of producing inert gas with an oxygen content at no time greater than 5% by volume, subject to the special requirements of Ch 9, Sec 17. A continuous-reading oxygen content meter shall be fitted to the inert gas supply from the equipment and shall be fitted with an alarm set at a maximum of 5% oxygen content by volume, subject to the requirements of Ch 9, Sec 17.*

1.5.4 *An inert gas system shall have pressure controls and monitoring arrangements appropriate to the cargo containment system.*

1.5.5 *Spaces containing inert gas generation plants shall have no direct access to accommodation spaces, service spaces or control stations, but may be located in machinery spaces. Inert gas piping shall not pass through accommodation spaces, service spaces or control stations.*

1.5.6 *Combustion equipment for generating inert gas shall not be located within the cargo area. Special consideration may be given to the location of inert gas generating equipment using a catalytic combustion process.*

1.6 Engineering specifications for nitrogen / inert gas systems

1.6.1 Requirements of:

- Pt C, Ch 4, Sec 15, [13.2.2], item b)
- Pt C, Ch 4, Sec 15, [13.2.2], item d)
- Pt C, Ch 4, Sec 15, [13.2.4], item b)
- Pt C, Ch 4, Sec 15, [13.2.4], item c)
- Pt C, Ch 4, Sec 15, [13.2.4], item e) 1) regarding oxygen content and power supply to the indicating devices
- Pt C, Ch 4, Sec 15, [13.2.4], item e) 4)
- Pt C, Ch 4, Sec 15, [13.4.2] and
- Pt C, Ch 4, Sec 15, [13.4.3],

apply to the systems.

1.6.2 The nitrogen generator is to be capable of delivering high purity nitrogen in accordance with Pt C, Ch 4, Sec 15, [13.2.1], item b) 5). In addition to Pt C, Ch 4, Sec 15, [13.2.2], item d), the system is to be fitted with automatic means to discharge “off-spec” gas to the atmosphere during start-up and abnormal operation.

1.6.3 The feed air treatment system fitted to remove free water, particles and traces of oil from the compressed air as required by Pt C, Ch 4, Sec 15, [13.4.2], item b), is also to preserve the specification temperature.

1.6.4 The oxygen-enriched air from the nitrogen generator and the nitrogen-product enriched gas from the protective devices of the nitrogen receiver are to be discharged to a safe location on the open deck.

Note 1: “safe location” needs to address the two types of discharges separately:

- oxygen-enriched air from the nitrogen generator - safe locations on the open deck are:
 - outside of hazardous area;
 - not within 3m of areas traversed by personnel; and
 - not within 6m of air intakes for machinery (engines and boilers) and all ventilation inlets
- nitrogen-product enriched gas from the protective devices of the nitrogen receiver - safe locations on the open deck are:
 - not within 3m of areas traversed by personnel; and
 - not within 6m of air intakes for machinery (engines and boilers) and all ventilation inlets/outlets.

1.6.5 In order to permit maintenance, means of isolation are to be fitted between the generator and the receiver.

1.6.6 The two non-return devices as required by Pt C, Ch 4, Sec 15, [13.2.3], item a) 1) are to be fitted in the inert gas main. The non-return devices are to comply with Pt C, Ch 4, Sec 15, [13.2.3], item a) 2) and Pt C, Ch 4, Sec 15, [13.2.3], item a) 3); however, where the connections to the cargo tanks, to the hold spaces or to cargo piping are not permanent, the non-return devices required by Pt C, Ch 4, Sec 15, [13.2.3], item a) 1) may be substituted by two non-return valves.

Section 10 Electrical Installations

1 General

1.1 Application

1.1.1 The requirements in this Section apply, in addition to those contained in Part C, Chapter 2 to gas carriers.

1.2 Documentation to be submitted

1.2.1 In addition to the documentation requested in Pt C, Ch 2, Sec 1, Tab 1 the following are to be submitted for approval:

- a) plan of hazardous areas
- b) document giving details of types of cables and safety characteristics of the equipment installed in hazardous areas
- c) diagrams of tank level indicator systems, high level alarm systems and overflow control systems where requested.

1.3 Definitions

1.3.1 For the purpose of this Section, unless expressly provided otherwise, the definitions below shall apply.

1.3.2 Hazardous area

Hazardous area is an area in which an explosive gas atmosphere is or may be expected to be present, in quantities such as to require special precautions for the construction, installation and use of electrical apparatus.

Note 1: Examples of hazardous area zoning may be found in Tab 1.

1.3.3 Zone 0 hazardous

Zone 0 hazardous area is an area in which an explosive gas atmosphere is present continuously or is present for long periods.

1.3.4 Zone 1 hazardous

Zone 1 hazardous area is an area in which an explosive gas atmosphere is likely to occur in normal operation.

1.3.5 Zone 2 hazardous

Zone 2 hazardous area is an area in which an explosive gas atmosphere is not likely to occur in normal operation and, if it does occur, is likely to do so infrequently and for a short period only.

1.3.6 Non-hazardous

Non-hazardous area is an area in which an explosive gas atmosphere is not expected to be present in quantities such as to require special precautions for the construction, installation and use of electrical apparatus.

1.4 General requirements

1.4.1 *Electrical installations shall be such as to minimize the risk of fire and explosion from flammable products.*

1.4.2 *Suitable arrangements are to be provided, to the satisfaction of the Society, so as to prevent the possibility of gases or vapours passing from a hazardous area to another area through runs of cables or their conduits.*

1.4.3 *Electrical installations shall be in accordance with recognized standards.*

Note 1: Refer to the recommendation published by the International Electrotechnical Commission in particular to publication IEC 60092-502:1999.

However, where the prescriptive requirements in the present Rules and IEC 60092-502 are not aligned, the prescriptive requirements in the present Rules take precedence and are to be applied.

1.4.4 *Electrical equipment or wiring shall not be installed in hazardous areas, unless essential for operational purposes or safety enhancement.*

1.4.5 *Where electrical equipment is installed in hazardous areas as provided in [1.4.4], it shall be selected, installed and maintained in accordance with standards not inferior to those acceptable to the Society. The types of electrical equipment admitted, depending on the zone where they are installed, are specified in Pt C, Ch 2, Sec 3, [10]. Equipment for hazardous areas shall be type approved by the Society. Automatic isolation of non-certified equipment on detection of a flammable gas shall not be accepted as an alternative to the use of certified equipment.*

1.4.6 *To facilitate the selection of appropriate electrical apparatus and the design of suitable electrical installations, hazardous areas are divided into zone 0, 1 and 2 according to [1.3]. The different spaces are to be classified according to Tab 1.*

Table 1 : Space descriptions and hazardous area zones

No.	Description of spaces	Hazardous area
1	The interior of cargo tanks, any pipework of pressure-relief or other venting systems for cargo, pipes and equipment containing the cargo or developing flammable gases and vapours	Zone 0
2	Interbarrier spaces, hold spaces where cargo is carried in a cargo containment system requiring a secondary barrier	Zone 0
3	Void space adjacent to, above or below integral cargo tanks	Zone 1
4	Hold spaces where cargo is carried in a cargo containment system not requiring a secondary barrier	Zone 1
5	Cofferdams and permanent (for example, segregated) ballast tanks adjacent to cargo tanks	Zone 1
6	Cargo pump rooms and cargo compressor rooms	Zone 1
7	Enclosed or semi-enclosed spaces, immediately above cargo tanks (for example, between decks) or having bulkheads above and in line with cargo tank bulkheads, unless protected by a diagonal plate acceptable to the society	Zone 1
8	Spaces, other than cofferdam, adjacent to and below the top of a cargo tank (for example, trunks, passageways and hold)	Zone 1
9	Areas on open deck, or semi-enclosed spaces on open deck, within 3 m of any cargo tank outlet, gas or vapour outlet, cargo manifold valve, cargo valve, cargo pipe flange, cargo pump-room ventilation outlets, cargo compressor room ventilation outlets and cargo tank openings for pressure release provided to permit the flow of small volumes of gas or vapour mixtures caused by thermal variation	Zone 1
10	Areas on open deck, or semi-enclosed spaces on open deck above and in the vicinity of any cargo gas outlet intended for the passage of large volumes of gas or vapour mixture during cargo loading and ballasting or during discharging, within a vertical cylinder of unlimited height and 6 m radius centred upon the centre of the outlet, and within a hemisphere of 6 m radius below the outlet	Zone 1
11	Areas on open deck, or semi-enclosed spaces on open deck, within 1,5 m of cargo pump room entrances, cargo pump room ventilation inlet, openings into cofferdams, cargo compressor room entrances, cargo compressor room ventilation inlets or other zone 1 spaces	Zone 1
12	Areas on open deck within spillage coamings surrounding cargo manifold valves and 3 m beyond these, up to a height of 2,4 m above the deck	Zone 1
13	Areas on open deck over the cargo area where structures are restricting the natural ventilation and to the full breadth of the ship plus 3 m fore and aft of the forward-most and aft-most cargo tank bulkhead, up to a height of 2,4 m above the deck	Zone 1
14	Compartments for cargo hoses	Zone 1
15	Enclosed or semi-enclosed spaces in which pipes containing cargoes are located	Zone 1
16	A space separated from a hold space, where cargo is carried in a cargo tank requiring a secondary barrier, by a single gastight boundary	Zone 1
17	Enclosed or semi-enclosed spaces in which pipes containing cargo products for boil-off gas fuel burning systems are located, unless special precautions approved by the society are provided to prevent product gas escaping into such spaces	Zone 1
18	Areas of 1,5 m surrounding a space of zone 1	Zone 2
19	Spaces 4 m beyond the cylinder and 4 m beyond the sphere defined in item 10	Zone 2
20	The spaces forming an airlock as defined in Ch 9, Sec 3, [1.6]	Zone 2
21	Areas on open deck extending to the coamings fitted to keep any spills on deck and away from the accommodation and service area and 3 m beyond these up to a height of 2,4 m above the deck.	Zone 2
22	Areas on open deck over the cargo area where unrestricted natural ventilation is guaranteed and to the full breadth of the ship plus 3 m fore and aft of the forward-most and aft-most cargo tank bulkhead, up to a height of 2,4 m above the deck surrounding open or semi-enclosed spaces of zone 1.	Zone 2
23	Spaces forward of the open deck areas to which reference is made in 13 and 22, below the level of the main deck, and having an opening on to the main deck or at a level less than 0,5 m above the main deck, unless: <ul style="list-style-type: none"> • the doors and all openings are in non-hazardous area; and • the spaces are mechanically ventilated 	Zone 2
24	An area within 2,4 m of the outer surface of a cargo tank where such surface is exposed to the weather.	Zone 2

1.4.7 *Electrical generation and distribution systems, and associated control systems shall be designed such that a single fault will not result in the loss of ability to maintain cargo tank pressures, as required by Ch 9, Sec 7, [8.1.1], item a) and hull structure temperature, as required by Ch 9, Sec 4, [5.2.1], item f), within normal operating limits. Failure modes and effects shall be analysed and documented to a standard not inferior to those acceptable to the Administration.*

Note 1: IEC 60812, Edition 2.0 2006-01 "Analysis techniques for system reliability - Procedure for failure mode and effects analysis (FMEA)".

1.4.8 *The lighting system in hazardous areas shall be divided between at least two branch circuits. All switches and protective devices shall interrupt all poles or phases and shall be located in a non-hazardous area.*

1.4.9 *Electrical depth sounding or log devices and impressed current cathodic protection system anodes or electrodes shall be housed in gastight enclosures.*

1.4.10 *Submerged cargo pump motors and their supply cables may be fitted in cargo containment systems. Arrangements shall be made to automatically shut down the motors in the event of low-liquid level. This may be accomplished by sensing low pump discharge pressure, low motor current or low liquid level. This shutdown shall be alarmed at the cargo control station. Cargo pump motors shall be capable of being isolated from their electrical supply during gas-freeing operations.*

1.5 System of supply

1.5.1 Acceptable systems of supply

The following systems of generation and distribution of electrical energy are acceptable:

- a) direct current:
 - two-wire insulated
- b) alternating current:
 - single-phase, two-wire insulated
 - three-phase, three-wire insulated.

In insulated distribution systems, no current carrying part is to be earthed, other than:

- a) through an insulation level monitoring device
- b) through components used for the suppression of interference in radio circuits.

1.5.2 Earthed system with hull return

Earthed systems with hull return are not permitted, with the following exceptions to the satisfaction of the Society:

- a) impressed current cathodic protective systems
- b) limited and locally earthed systems, such as starting and ignition systems of internal combustion engines, provided that any possible resulting current does not flow directly through any hazardous area
- c) insulation level monitoring devices, provided that the circulation current of the device does not exceed 30 mA under the most unfavourable conditions.

1.5.3 Earthed systems without hull return

Earthed systems without hull return are not permitted, with the following exceptions:

- a) earthed intrinsically safe circuits and the following other systems to the satisfaction of the Society
- b) power supplies, control circuits and instrumentation circuits in non-hazardous areas where technical or safety reasons preclude the use of a system with no connection to earth, provided the current in the hull is limited to not more than 5 A in both normal and fault conditions, or
- c) limited and locally earthed systems, such as power distribution systems in galleys and laundries to be fed through isolating transformers with the secondary windings earthed, provided that any possible resulting hull current does not flow directly through any hazardous area, or
- d) alternating current power networks of 1,000 V root mean square (line to line) and over, provided that any possible resulting current does not flow directly through any hazardous area; to this end, if the distribution system is extended to areas remote from the machinery space, isolating transformers or other adequate means are to be provided.

1.6 Earth detection

1.6.1 Monitoring of circuits in hazardous areas

The devices intended to continuously monitor the insulation level of all distribution systems are also to monitor all circuits, other than intrinsically safe circuits, connected to apparatus in hazardous areas or passing through such areas. An audible and visual alarm is to be given, at a manned position, in the event of an abnormally low level of insulation.

1.7 Mechanical ventilation of hazardous spaces

1.7.1 Electric motors driving fans of the ventilating systems of hazardous spaces are to be located outside the ventilation ducting.

1.7.2 Motors driving ventilating fans may be located within the ducting provided that they are of a certified safe type.

1.7.3 The materials used for the fans and their housing are to be in compliance with Pt C, Ch 4, Sec 1, [3.32].

1.7.4 Cargo compressor rooms and other enclosed spaces which contain cargo-handling equipment and similar spaces in which work is performed on the cargo should be fitted with mechanical ventilation systems, capable of being controlled from outside such spaces.

1.7.5 Provisions are to be made to ventilate the spaces defined in [1.7.4] prior to entering the compartment and operating the equipment.

2 Hazardous locations and types of equipment

2.1 Electrical equipment permitted in gas-dangerous spaces and zones

2.1.1 A space separated by a gastight boundaries from a hazardous area may be classified as zone 0, 1, 2 or considered as non hazardous, taking into account the sources of release inside that space and its conditions of ventilation.

2.1.2 Access door and other openings are not to be provided between an area intended to be considered as non-hazardous and a hazardous area or between a space intended to be considered as zone 2 and a zone 1, except where required for operational reasons.

2.1.3 In enclosed or semi-enclosed spaces having a direct opening into any hazardous space or area, electrical installations are to comply with the requirements for the space or area to which the opening leads.

2.1.4 Where a space has an opening into an adjacent, more hazardous space or area, it may be made into a less hazardous space or non-hazardous space, taking into account the type of separation and the ventilation system.

2.1.5 A differential pressure monitoring device or a flow monitoring device, or both, are to be provided for monitoring the satisfactory functioning of pressurisation of spaces having an opening into a more hazardous zone.

In the event of loss of the protection by the over-pressure or loss of ventilation in spaces classified as zone 1 or zone 2, protective measures are to be taken.

2.2 Submerged cargo pumps

2.2.1 Exceptions

Submerged cargo pumps are not permitted in connection with the following cargoes:

- diethyl ether
- vinyl ethyl ether
- ethylene oxide
- propylene oxide
- mixtures of ethylene oxide and propylene oxide.

2.2.2 Submerged electric motors

In addition to the requirements of [1.4.10], where submerged electric motors are employed, means are to be provided, e.g. by the arrangements specified in Ch 9, Sec 17, [6] to avoid the formation of explosive mixtures during loading, cargo transfer and unloading.

3 Product classification

3.1 Temperature class and explosion group

3.1.1 Tab 2 specifies temperature class and explosion group data for the products indicated in Ch 9, Sec 19. The data shown in brackets have been derived from similar products.

Table 2 : Temperature class and explosion group of certain products

Product name	Temperature class	Explosion group
Acetaldehyde	T4	II A
Ammonia anhydrous	T1	II A
Butadiene	T2	II B
Butane	T2	II A
Butane/propane mixture	T2	II A
Butylenes	T3	II A
Carbon dioxide	NF	NF

Product name	Temperature class	Explosion group
Chlorine	NF	NF
Diethyl ether	T4	II B
Dimethylamine	T2	II A
Dimethyl ether	T3	II B
Ethane	T1	II A
Ethyl chloride	T2	II A
Ethylene	T2	II B
Ethylene oxide	T2	II B
Ethylene oxide propylene oxide mixture (max. 30% w/w ethylene oxide)	T2	II B
Isoprene	T3	II B
Isopropylamine	T2	II A
Methane	T1	II A
Methyl acetylene propadiene mixture	T4	II A
Methyl bromide	T3	II A
Methyl chloride	T1	II A
Monoethylamine	T2	II A
Nitrogen	NF	NF
Pentane (all isomers)	(T2)	(II A)
Pentene (all isomers)	(T3)	(II B)
Propane	T1	II A
Propylene	T2	II B
Propylene oxide	T2	II B
Refrigerant gases	NF	NF
Sulphur dioxide	(T3)	(II B)
Vinyl chloride	T2	II A
Vinyl ethyl ether	T3	II B
Vinylidene chloride	T2	II A

Section 11 Fire Protection and Extinction

1 General

1.1 Fire safety requirements

1.1.1 The requirements for tankers in SOLAS chapter II-2 shall apply to ships covered by the Code, irrespective of tonnage including ships of less than 500 gross tonnage, except that:

- a) regulations 4.5.1.6 and 4.5.10 do not apply
- b) requirements of 10.4 and 10.5 shall apply as they would apply to tankers of 2,000 gross tonnage and over
- c) regulation 10.5.6 shall apply to ships of 2,000 gross tonnage and over
- d) the regulations of SOLAS chapter II-2 related to tankers listed in Tab 1 do not apply and are replaced by requirements of this Chapter as detailed in Tab 1
- e) regulations 13.3.4 and 13.4.3 shall apply to ships of 500 gross tonnage and over.

Table 1 :

SOLAS Chapter II-2 Regulation	Replaced by the following requirements
10.10	[1.6]
4.5.1.1 and 4.5.1.2	Ch 9, Sec 3
4.5.5	Relevant requirements in this Section
10.8	[1.3] and [1.4]
10.9	[1.5]
10.2	from [1.2.1] to [1.2.4]

1.1.2 All sources of ignition shall be excluded from spaces where flammable vapour may be present, except as otherwise provided in Ch 9, Sec 10 and Ch 9, Sec 16.

1.1.3 The maximum temperature of the steam and heating media in the cargo area is to be adjusted to take into account the temperature class of the cargo.

1.1.4 The provisions of this Section shall apply in conjunction with Ch 9, Sec 3.

1.1.5 For the purposes of fire fighting, any weather deck areas above cofferdams, ballast or void spaces at the after end of the aftermost hold space or at the forward end of the forwardmost hold space shall be included in the cargo area.

1.2 Fire mains and hydrants

1.2.1 Irrespective of size, ships carrying products that are subject to the Code shall comply with the requirements of regulation II-2/10.2 of the SOLAS Convention, as applicable to cargo ships, except that the required fire pump capacity and fire main and water service pipe diameter shall not be limited by the provisions of regulations II-2/10.2.2.4.1 and II-2/10.2.1.3, when a fire pump is used to supply the water-spray system, as permitted by [1.3.5]. The capacity of this fire pump shall be such that these areas can be protected when simultaneously supplying two jets of water from fire hoses with 19 mm nozzles at a pressure of at least 0.5 MPa gauge.

1.2.2 The arrangements shall be such that at least two jets of water can reach any part of the deck in the cargo area and those portions of the cargo containment system and tank covers that are above the deck. The necessary number of fire hydrants shall be located to satisfy the above arrangements and to comply with the requirements of regulations II-2/10.2.1.5.1 and II-2/10.2.3.3 of the SOLAS Convention, with hose lengths as specified in regulation II-2/10.2.3.1.1. In addition, the requirements of regulation II-2/10.2.1.6 shall be met at a pressure of at least 0.5 MPa gauge.

1.2.3 Stop valves shall be fitted in any crossover provided and in the fire main or mains in a protected location, before entering the cargo area and at intervals ensuring isolation of any damaged single section of the fire main, so that [1.2.2] can be complied with using not more than two lengths of hoses from the nearest fire hydrant. The water supply to the fire main serving the cargo area shall be a ring main supplied by the main fire pumps or a single main supplied by fire pumps positioned fore and aft of the cargo area, one of which shall be independently driven.

1.2.4 Nozzles shall be of an approved dual-purpose type (i.e. spray/jet type) incorporating a shutoff.

1.2.5 After installation, the pipes, valves, fittings and assembled system shall be subject to a tightness and function test.

1.2.6 When the ship is fitted with a total flooding high expansion foam system protecting the engine-room (to comply with Pt C, Ch 4, Sec 6, [3.1.1], item b) and Pt C, Ch 4, Sec 6, [4.2.1]) and the emergency fire pump is intended to supply sea water to this system and to the water-spray system in pursuance of [1.3.6], then, the emergency fire pump is to be sized to cover the foam system for dealing with an engine-room fire, when the main fire pumps are disabled. On the basis of the principle of dealing with one single fire incident at a time, the emergency fire pump does not need to be sized to cover all three systems above (i.e. water spray, hydrants and foam) at the same time and only needs to be sized to cover the most demanding area and required systems, as follows:

- the foam system + two hydrants; or
- the water spray system + two hydrants;

whichever is greater.

1.3 Water-spray system

1.3.1 A stop valve is to be fitted on the water-spray main as close as possible to the poop front so that the accommodation spaces are always protected in the case of a spray-main failure.

1.3.2 *On ships carrying flammable and/or toxic products, a water-spray system, for cooling, fire prevention and crew protection shall be installed to cover:*

- exposed cargo tank domes, any exposed parts of cargo tanks and any part of cargo tank covers that may be exposed to heat from fires in adjacent equipment containing cargo such as exposed booster pumps/heaters/re-gasification or re-liquefaction plants, hereafter addressed as gas process units, positioned on weather decks*
- exposed on-deck storage vessels for flammable or toxic products*
- gas process units positioned on deck*
- cargo liquid and vapour discharge and loading connections, including the presentation flange and the area where their control valves are situated, which shall be at least equal to the area of the drip trays provided*
- all exposed emergency shut-down (ESD) valves in the cargo liquid and vapour pipes, including the master valve for supply to gas consumers*
- exposed boundaries facing the cargo area, such as bulkheads of superstructures and deckhouses normally manned, cargo machinery spaces, store-rooms containing high fire-risk items and cargo control rooms. Exposed horizontal boundaries of these areas do not require protection unless detachable cargo piping connections are arranged above or below. Boundaries of unmanned forecastle structures not containing high fire-risk items or equipment do not require water-spray protection*
- exposed lifeboats, liferafts and muster stations facing the cargo area, regardless of distance to cargo area, and*

Note 1: The survival crafts on board including remote survival crafts required by SOLAS III/31.1.4 facing the cargo area are to be protected by a water-spray system taking into consideration cargo area extension for fire-fighting purposes as stated in [1.1.5].

Remote liferafts located in areas covered by water-spray protection as required in item f) may be considered as adequately protected.

- any semi-enclosed cargo machinery spaces and semi-enclosed cargo motor room.*

Ships intended for operation as listed in Ch 9, Sec 1, [2.1.10] shall be subject to special consideration (see [1.3.5]).

The water spray system mentioned in [1.3.2] is also to cover boundaries of spaces containing internal combustion engines and/or fuel treatment units, of store-rooms for flammable liquids having a flashpoint equal to or less than 60°C and of paint lockers.

1.3.3 *The system shall be capable of covering all areas mentioned in [1.3.2], with a uniformly distributed water application rate of at least 10 litre/m²/min for the largest projected horizontal surfaces and 4 litre/m²/min for vertical surfaces. For structures having no clearly defined horizontal or vertical surface, the capacity of the water-spray system shall not be less than the projected horizontal surface multiplied by 10 l/m²/min.*

1.3.4 *On vertical surfaces, spacing of nozzles protecting lower areas may take account of anticipated rundown from higher areas. Stop valves shall be fitted in the main supply line(s) in the water-spray system, at intervals not exceeding 40 m, for the purpose of isolating damaged sections. Alternatively, the system may be divided into two or more sections that may be operated independently, provided the necessary controls are located together in a readily accessible position outside the cargo area. A section protecting any area included in [1.3.2], items a) and b), shall cover at least the entire athwartship tank grouping in that area. Any gas process unit(s) included in [1.3.2] may be served by an independent section.*

The number and location of spray nozzles are to be suitable to spread the sprayed water uniformly on areas to be protected.

1.3.5 *The capacity of the water-spray pumps shall be capable of simultaneous protection of the greater of the following:*

- any two complete athwartship tank groupings, including any gas process units within these areas, or*

Note 1: The expression "two complete athwartship tank groupings" means any two groups of tanks where one group is defined as tanks located in transverse direction from ship side to ship side. Where there is only one cargo tank occupying a hold space from ship side to ship side, it will be considered as a "grouping" for the purpose of this requirement.

"Any two complete athwartship tank groupings" represents an area equal to the combined area of the two largest tank groupings including any gas process units within these areas.

b) for ships intended for operation as listed in Ch 9, Sec 1, [2.1.10], necessary protection subject to special consideration under [1.3.2] of any added fire hazard and the adjacent athwartship tank grouping,

in addition to surfaces specified in [1.3.2] Alternatively, the main fire pumps may be used for this service, provided that their total capacity is increased by the amount needed for the water-spray system. In either case, a connection, through a stop valve, shall be made between the fire main and water-spray system main supply line outside the cargo area.

1.3.6 The boundaries of superstructures and deckhouses normally manned, and lifeboats, liferafts and muster areas facing the cargo area, shall also be capable of being served by one of the fire pumps or the emergency fire pump, if a fire in one compartment could disable both fire pumps.

If all the fire pumps supplying the water spray system (for covering the superstructures and deckhouses) may be disabled due to a fire in any one compartment; then the emergency fire pump is to be sized to cover:

- the water spray system for the boundaries of the superstructures and deckhouses, and lifeboats, liferafts and muster areas facing the cargo area; and
- two fire hydrants as required by [1.2.2].

Note 1: The term "fire pumps" where not qualified by the word "emergency" refers to the fire pumps required in accordance with Pt C, Ch 4, Sec 6, [1.2.6], item b).

Note 2: The expression "fire in one compartment" means a compartment provided with A-class boundaries in which is located the fire pump(s), or the source of power of the fire pump(s), serving the water-spray system in accordance with [1.3.5].

1.3.7 Water pumps normally used for other services may be arranged to supply the water-spray system main supply line.

1.3.8 All pipes, valves, nozzles and other fittings in the water-spray system shall be resistant to corrosion by seawater. Piping, fittings and related components within the cargo area (except gaskets) shall be designed to withstand 925°C. The water-spray system shall be arranged with in-line filters to prevent blockage of pipes and nozzles. In addition, means shall be provided to back-flush the system with fresh water.

Where fuel oil tanks are installed at the after end of the aftermost hold space or at the forward end of the forwardmost hold space instead of cofferdams as allowed for in requirement of Ch 9, Sec 3, [1.1.3] and Ch 9, Sec 3, [1.1.4], the weather deck area above these tanks is to be regarded as a "cargo area" for the purpose of applying this requirement.

1.3.9 Remote starting of pumps supplying the water-spray system and remote operation of any normally closed valves in the system shall be arranged in suitable locations outside the cargo area, adjacent to the accommodation spaces and readily accessible and operable in the event of fire in the protected areas.

1.3.10 After installation, the pipes, valves, fittings and assembled system shall be subject to a tightness and function test.

1.4 Dry chemical powder fire-extinguishing systems

1.4.1 Ships in which the carriage of flammable products is intended shall be fitted with fixed dry chemical powder fire-extinguishing systems, approved by the Society based on IMO Circular MSC.1/Circ.1315 for the purpose of fire fighting on the deck in the cargo area, including any cargo liquid and vapour discharge and loading connections on deck and bow or stern cargo handling areas, as applicable.

Note 1: Dry chemical powder is to be based on potassium bicarbonate.

1.4.2 The system shall be capable of delivering powder from at least two hand hose lines, or a combination of monitor/hand hose lines, to any part of the exposed cargo liquid and vapour piping, load/unload connection and exposed gas process units.

1.4.3 The dry chemical powder fire-extinguishing system shall be designed with not less than two independent units. Any part required to be protected by [1.4.2] shall be capable of being reached from not less than two independent units with associated controls, pressurizing medium fixed piping, monitors or hand hose lines. For ships with a cargo capacity of less than 1,000 m³, only one such unit need be fitted. A monitor shall be arranged to protect any load/unload connection area and be capable of actuation and discharge both locally and remotely. The monitor is not required to be remotely aimed, if it can deliver the necessary powder to all required areas of coverage from a single position. One hose line shall be provided at both port- and starboard side at the end of the cargo area facing the accommodation and readily available from the accommodation.

1.4.4 Powder systems are to be in accordance with the following requirements:

- a) Two powder units, even if mutually connected through a common main, may be considered independent on condition that non-return valves or other arrangements suitable to prevent powder from passing from one unit to the other are fitted.
- b) The powder units which constitute the system are to contain, in general, the same powder quantity and, when they are not grouped together in a single position, they are to be uniformly located over the area to be protected.
- c) Where powder units are grouped together in a single position or, in the case of ships having a cargo capacity less than 1000 m³, a single powder unit is installed, the said units are to be located aft of the cargo area.

1.4.5 *The capacity of a monitor shall be not less than 10kg/s. Hand hose lines shall be non-kinkable and be fitted with a nozzle capable of on/off operation and discharge at a rate not less than 3.5 kg/s. The maximum discharge rate shall allow operation by one man. The length of a hand hose line shall not exceed 33m. Where fixed piping is provided between the powder container and a hand hose line or monitor, the length of piping shall not exceed that length which is capable of maintaining the powder in a fluidized state during sustained or intermittent use, and which can be purged of powder when the system is shut down. Hand hose lines and nozzles shall be of weather-resistant construction or stored in weather resistant housing or covers and be readily accessible.*

1.4.6 *Hand hose lines shall be considered to have a maximum effective distance of coverage equal to the length of hose. Special consideration shall be given where areas to be protected are substantially higher than the monitor or hand hose reel locations.*

1.4.7 *Ships fitted with bow/stern load/unload connections shall be provided with independent dry powder unit protecting the cargo liquid and vapour piping, aft or forward of the cargo area, by hose lines and a monitor covering the bow/stern load/unload complying with the requirements from [1.4.1] to [1.4.6].*

1.4.8 *Ships intended for operation as listed in Ch 9, Sec 1, [2.1.10] shall be subject to special consideration.*

1.4.9 *After installation, the pipes, valves, fittings and assembled systems shall be subjected to a tightness test and functional testing of the remote and local release stations. The initial testing shall also include a discharge of sufficient amounts of dry chemical powder to verify that the system is in proper working order. All distribution piping shall be blown through with dry air to ensure that the piping is free of obstructions.*

Testing arrangements are to involve the discharge using dry chemical powder from all monitors and hand hose lines on board but it is not required that there is a full discharge of the installed quantity of dry powder. This testing can also be used to satisfy the requirement that the piping is free of obstructions, in lieu of blowing through with dry air all the distribution piping. However, after the completion of this testing, the system, including all monitors and hand hose lines, are to be blown through with dry air but only for the purpose of the system subsequently being clear from any residues of dry chemical powder.

1.5 Enclosed spaces containing cargo handling equipment

1.5.1 In pump rooms and cargo compressor rooms, at least two portable extinguishers of a recognised type are to be fitted.

1.5.2 *Enclosed spaces meeting the criteria of cargo machinery spaces in Ch 9, Sec 1, [4.1.11], and the cargo motor room within the cargo area of any ship, shall be provided with a fixed fire-extinguishing system complying with the provisions of the Pt C, Ch 4, Sec 15 and taking into account the necessary concentrations/application rate required for extinguishing gas fires.*

1.5.3 Audible alarms fitted to warn of the release of fire extinguishing medium into pump rooms, are to be of the pneumatic type or electric type.

- a) In cases where the periodic testing of pneumatically operated alarms is required, CO₂ operated alarms should not be used owing to the possibility of the generation of static electricity in the CO₂ cloud. Air operated alarms may be used provided the air supply is clean and dry.
- b) When electrically operated alarms are used, the arrangements are to be such that the electric actuating mechanism is located outside the pump room except where the alarms are certified intrinsically safe.

1.5.4 *Enclosed spaces meeting the criteria of cargo machinery spaces in Ch 9, Sec 3, [1.3], within the cargo area of ships that are dedicated to the carriage of a restricted number of cargoes, shall be protected by an appropriate fire-extinguishing system for the cargo carried.*

1.5.5 *Turret compartments of any ship shall be protected by internal water spray, with an application rate of not less than 10 litre/m²/min of the largest projected horizontal surface. If the pressure of the gas flow through the turret exceeds 4 MPa, the application rate shall be increased to 20 litre/m²/min. The system shall be designed to protect all internal surfaces.*

Note 1: The sentence "shall be designed to protect all internal surfaces" should be interpreted as follows as follows:

- any horizontal internal surface (e.g. platform) is to be protected
- Additional nozzles are to be considered if necessary
- the surface of the internal surfaces has to be added to the largest projected horizontal surface in order to determine the required water capacity

1.6 Firefighter's outfits

1.6.1 Every ship carrying flammable products shall carry firefighter's outfits complying with the requirements of regulation II-2/10.10 of the SOLAS Convention, as in Tab 2.

Table 2 :

Total cargo capacity	Number of outfits
5,000 m ³ and below	4
Above 5,000 m ³	5

1.6.2 Additional requirements for safety equipment are given in Ch 9, Sec 14.

1.6.3 Any breathing apparatus required as part of a firefighter's outfit shall be a self-contained compressed air-operated breathing apparatus having a capacity of at least 1,200 litres of free air.

Section 12 Artificial Ventilation in the Cargo Area

1 General

1.1 Scope

1.1.1 *The requirements of this Section replace the requirements of SOLAS regulations II-2/4.5.2.6 and 4.5.4.1, as amended.*

1.2 Spaces required to be entered during normal cargo handling operations

1.2.1 *Electric motor rooms, cargo compressor and pump-rooms, spaces containing cargo handling equipment and other enclosed spaces where cargo vapours may accumulate shall be fitted with fixed artificial ventilation systems capable of being controlled from outside such spaces. The ventilation shall be run continuously to prevent the accumulation of toxic and/or flammable vapours, with a differential pressure monitoring device or flow monitoring device to indicate any loss of the required ventilating capacity. A warning notice requiring the use of such ventilation prior to entering shall be placed outside the compartment.*

1.2.2 *Artificial ventilation inlets and outlets shall be arranged to ensure sufficient air movement through the space to avoid accumulation of flammable, toxic or asphyxiant vapours, and to ensure a safe working environment.*

1.2.3 *The ventilation system shall have a capacity of not less than 30 changes of air per hour, based upon the total volume of the space. As an exception, non-hazardous cargo control rooms may have eight changes of air per hour.*

1.2.4 *Where a space has an opening into an adjacent more hazardous space or area, it shall be maintained at an overpressure. It may be made into a less hazardous space or non-hazardous space by overpressure protection in accordance with recognized standards.*

1.2.5 *Ventilation ducts, air intakes and exhaust outlets serving artificial ventilation systems shall be positioned in accordance with recognized standards.*

Note 1: Refer to the recommendation published by the International Electrotechnical Commission, in particular, to publication IEC 60092-502:1999.

However, where the prescriptive requirements in the present Rules and IEC 60092-502 are not aligned, the prescriptive requirements in the present Rules take precedence and are to be applied.

1.2.6 *Ventilation ducts are to be arranged at a suitable height from the weather deck. This height is not to be less than 2,4 m for intake ducts.*

Note 1: Hazardous areas for this purpose are those mentioned in [1.2.11] For other spaces which are gas-dangerous only due to their position, some relaxation may be granted.

1.2.7 *Ventilation ducts are to be fitted with metallic fire dampers provided with "open" and "closed" signs. These dampers are to be arranged in the open, in a readily accessible position.*

1.2.8 *In particular, the discharges from ventilation systems which may contain hazardous vapours are to be located not less than 8 m from the nearest air intake or opening to accommodation, service and control station spaces or other safe spaces, and from all possible sources of ignition.*

1.2.9 *Ventilation intakes and outlets and openings of accommodation spaces, control stations and other gas-safe spaces are to be located in a designated safe area and at least 3 m from any hazardous area.*

1.2.10 *The air inlets and discharges of the ventilation systems are to be situated so that recirculation of the vented vapours does not occur and are to be arranged at a distance from each other in the horizontal direction of not less than 3 m.*

1.2.11 *Ventilation ducts serving hazardous areas shall not be led through accommodation, service and machinery spaces or control stations, except as allowed in Ch 9, Sec 16.*

1.2.12 *Electric motors' driving fans shall be placed outside the ventilation ducts that may contain flammable vapours. Ventilation fans shall not produce a source of ignition in either the ventilated space or the ventilation system associated with the space. For hazardous areas, ventilation fans and ducts, adjacent to the fans, shall be of non-sparking construction, complying with Pt C, Ch 4, Sec 1, [3.32], and as defined below:*

- *impellers or housing of non-metallic construction, with due regard being paid to the elimination of static electricity*
- *impellers and housing of non-ferrous materials*
- *impellers and housing of austenitic stainless steel, and*
- *ferrous impellers and housing with design tip clearance of not less than 13 mm.*

Any combination of an aluminium or magnesium alloy fixed or rotating component and a ferrous fixed or rotating component, regardless of tip clearance, is considered a sparking hazard and Materials for non shall not be used in these places.

1.2.13 *The shafting penetration of motors driving fans through bulkheads and decks of dangerous spaces or through ventilation ducts is to be fitted with a gastight sealing device, of the oil- seal type or equivalent, deemed suitable by the Society.*

1.2.14 *Where fans are required by this Section, full required ventilation capacity for each space shall be available after failure of any single fan, or spare parts shall be provided comprising a motor, starter spares and complete rotating element, including bearings of each type.*

1.2.15 *Protection screens of not more than 13 mm square mesh shall be fitted to outside openings of ventilation ducts.*

1.2.16 *Where spaces are protected by pressurization, the ventilation shall be designed and installed in accordance with recognized standards.*

Note 1: Refer to the recommendation published by the International Electrotechnical Commission, in particular, to publication IEC 60092-502:1999.

However, where the prescriptive requirements in the present Rules and IEC 60092-502 are not aligned, the prescriptive requirements in the present Rules take precedence and are to be applied.

1.3 Spaces not normally entered

1.3.1 Both fixed and portable systems are to guarantee the efficient ventilation of such spaces in relation to the relative density, in respect of the air, and to the toxicity of the gases transported. The type of portable fans and their connection to the spaces served are to be approved by the Society. In no case are portable electrical fans acceptable.

1.3.2 *Enclosed spaces where cargo vapours may accumulate shall be capable of being ventilated to ensure a safe environment when entry into them is necessary. This shall be capable of being achieved without the need for prior entry.*

1.3.3 *For permanent installations, the capacity of 8 air changes per hour shall be provided and for portable systems, the capacity of 16 air changes per hour.*

1.3.4 *Fans or blowers shall be clear of personnel access openings, and shall comply with [1.2.12].*

Section 13 Instrumentation and Automation Systems

1 General

1.1

1.1.1 The instrumentation is to be of a type approved by the Society.

1.1.2 Attention is drawn to the requirements of Ch 9, Sec 1, [6.2.4] regarding the satisfactory operation of the cargo control and monitoring system and of the level alarm system, that is to be ascertained during the first full loading and the subsequent first unloading of ships carrying liquefied natural gasses (LNG) in bulk.

1.1.3 *Each cargo tank shall be provided with a means for indicating level, pressure and temperature of the cargo. Pressure gauges and temperature indicating devices shall be installed in the liquid and vapour piping systems, in cargo refrigeration installations.*

1.1.4 *If loading and unloading of the ship is performed by means of remotely controlled valves and pumps, all controls and indicators associated with a given cargo tank shall be concentrated in one control position.*

1.1.5 The following information and alarms are to be concentrated in the positions specified in this requirement:

- a) The following is to be transduced to the “cargo control room” and the “control position” as defined in Ch 9, Sec 3, [1.4.1]:
- the indication signalling the presence of water and/or liquid cargo in holds or interbarrier spaces
 - the cargo heater low temperature alarm required in Ch 9, Sec 4, [1.2.3]
 - the alarm signalling the presence of liquid cargo in the vent main as per in Ch 9, Sec 5, [2.2.4].
 - the indication of the hull temperature and the hull structure low temperature alarm required in [7.2.2].
 - the alarm signalling the automatic shutdown of electrically driven submerged pumps required in Ch 9, Sec 10, [1.4.10].
 - the indication of the cargo level and the cargo tank high level alarm required in [2.1.1].
 - the indication of the vapour space pressure and the vapour space pressure gauges of each cargo tank and associated high and low pressure alarms required in [4.1].
 - the gas detection equipment alarm required in [6.1.13]
 - the cargo compressor high temperature alarm required in Ch 9, Sec 17, [4.1.2] item b)
 - the alarm for automatic shutdown of the cargo compressor for high pressure or high temperature, as required in Ch 9, Sec 17, [16.1.4] item d)

When the cargo system is not remote controlled and therefore the aforesaid “control positions” are not required, the above-mentioned controls, information and alarms are to be located in a suitable, easily accessible location.

If this position is an enclosed space, it is to comply with the requirements in Ch 9, Sec 3, [1.3.7]. This position should preferably be located in the wheelhouse.

- b) Independently of the above, the following is to be transduced to the wheelhouse:
- 1) the alarm signalling the presence of water and/or liquid cargo in holds or interbarrier spaces
 - 2) the cargo heater low temperature alarm required in Ch 9, Sec 4, [1.2.3]
 - 3) the alarm signalling the presence of liquid cargo in the vent main as per Ch 9, Sec 5, [2.2.4]
 - 4) the indication of the pressure value in the vapour space of each cargo tank mentioned in [4.1]; such indication is to give the setting pressure value of the relief valve and the minimum allowable pressure value in the cargo tank concerned
 - 5) the high pressure and low pressure alarms, when required, for cargo tanks as per [4.1]
 - 6) the hull structure low temperature alarm required in [7.2.2]
 - 7) the gas detection equipment alarm required in [6.1.13]
 - 8) the cargo compressor high temperature alarm required in Ch 9, Sec 17, [4.1.2] item b)
 - 9) the alarm for automatic shutdown of the cargo compressor for high pressure or high temperature, as required in Ch 9, Sec 17, [16.1.4] item d)
- c) Where the cargo control room is located within the accommodation spaces and is readily accessible, the alarms in [3.1.5] may be grouped in a single audible and visual alarm except for the indication and alarms in [1.1.5] item b) 4), item b) 5) and item b) 7), which are to be independent from each other.
- d) The high level and high or low pressure audible and visual alarms for cargo tanks as per [3.1.1] and [3.1.4] and the alarm signalling the presence of liquid in the vent main are to be located in such a position as to be clearly heard and identifiable by the personnel in charge of loading operation control.

1.1.6 Instruments shall be tested to ensure reliability under the working conditions, and recalibrated at regular intervals. Test procedures for instruments and the intervals between recalibration shall be in accordance with manufacturer's recommendations.

2 Level indicators for cargo tanks

2.1 General

2.1.1 Each cargo tank shall be fitted with liquid level gauging device(s), arranged to ensure that a level reading is always obtainable whenever the cargo tank is operational. The device(s) shall be designed to operate throughout the design pressure range of the cargo tank and at temperatures within the cargo operating temperature range.

2.1.2 Where only one liquid level gauge is fitted, it shall be arranged so that it can be maintained in an operational condition without the need to empty or gas-free the tank.

In order to assess whether or not only one level gauge is acceptable in relation to the aforesaid sentence, the expression "can be maintained" means that any part of the level gauge other than passive parts can be overhauled while the cargo tank is in service.

Note 1: Passive parts are those parts assumed not subject to failures under normal service conditions.

2.1.3 Where level gauges containing cargo are arranged outside the tank they serve, means are to be provided to shut them off automatically in the event of failure.

2.1.4 Cargo tank liquid level gauges may be of the following types, subject to special requirements for particular cargoes shown in Ch 9, Sec 19, Tab 1, column "Gauging":

- a) indirect devices, which determine the amount of cargo by means such as weighing or in-line flow metering
- b) closed devices which do not penetrate the cargo tank, such as devices using radio-isotopes or ultrasonic devices
- c) closed devices which penetrate the cargo tank, but which form part of a closed system and keep the cargo from being released, such as float type systems, electronic probes, magnetic probes and bubble tube indicators. If closed gauging device is not mounted directly onto the tank, it shall be provided with a shutoff valve located as close as possible to the tank, and
- d) restricted devices which penetrate the tank and, when in use, permit a small quantity of cargo vapour or liquid to escape to the atmosphere, such as fixed tube and slip tube gauges. When not in use, the devices shall be kept completely closed. The design and installation shall ensure that no dangerous escape of cargo can take place when opening the device. Such gauging devices shall be so designed that the maximum opening does not exceed 1.5 mm diameter or equivalent area, unless the device is provided with an excess flow valve.

3 Overflow control

3.1 General

3.1.1 Except as provided in [3.1.5], each cargo tank shall be fitted with a high liquid level alarm operating independently of other liquid level indicators and giving an audible and visual warning when activated.

3.1.2 The sensor for automatic closing of the loading valve for overflow control may be combined with the liquid level indicators required by [2.1.1].

3.1.3 An additional sensor operating independently of the high liquid level alarm shall automatically actuate a shutoff valve in a manner that will both avoid excessive liquid pressure in the loading line and prevent the tank from becoming liquid full.

Note 1: The words 'to prevent the tank from becoming liquid full' in paragraph [3.1.3] have the following meaning:

At no time during the loading, transport or unloading of the cargo including fire conditions will the tank be more than 98% liquid full, except as permitted by Ch 9, Sec 15, [1.1.3]. These requirements, together with those of Ch 9, Sec 8, [2.1.20], are intended to ensure that the pressure relief valves remain in the vapour phase.

3.1.4 The emergency shutdown valve referred to in 5.5 and Ch 9, Sec 18, [3] may be used for this purpose. If another valve is used for this purpose, the same information as referred to in Ch 9, Sec 18, [3.2.1], item c) shall be available on board. During loading, whenever the use of these valves may possibly create a potential excess pressure surge in the loading system, alternative arrangements such as limiting the loading rate shall be used.

3.1.5 A high liquid level alarm and automatic shut-off of cargo tank filling need not be required, when the cargo tank:

- is a pressure tank with a volume not more than 200 m³, or
- is designed to withstand the maximum possible pressure during the loading operation, and such pressure is below that of the set pressure of the cargo tank relief valve.

3.1.6 The position of the sensors in the tank shall be capable of being verified before commissioning. At the first occasion of full loading after delivery and after each dry-docking, testing of high-level alarms shall be conducted by raising the cargo liquid level in the cargo tank to the alarm point.

Note 1: The expression “each dry docking” is considered to be the survey of the outside of the ship’s bottom required for the renewal of the Cargo Ship Safety Construction Certificate and or the Cargo Ship Safety Certificate.

3.1.7 All elements of the level alarms, including the electrical circuit and the sensor(s), of the high, and overflow alarms, shall be capable of being functionally tested. Systems shall be tested prior to cargo operation in accordance with IGC Code, 18.6.2.

3.1.8 Where arrangements are provided for overriding the overflow control system, they shall be such that inadvertent operation is prevented. When this override is operated, continuous visual indication shall be given at the relevant control station(s) and the navigation bridge.

4 Pressure monitoring

4.1 General

4.1.1 The vapour space of each cargo tank shall be provided with a direct reading gauge. Additionally, an indirect indication shall be provided at the control position required by [1.1.4]. Maximum and minimum allowable pressures shall be clearly indicated.

4.1.2 A high-pressure alarm and, if vacuum protection is required as defined in Ch 9, Sec 8, [3], a low-pressure alarm shall be provided on the navigation bridge and at the control position required by [1.1.4]. Alarms shall be activated before the set pressures are reached. The low pressure alarm is also to be located in the cargo control room.

4.1.3 For cargo tanks fitted with PRVs which can be set at more than one set pressure in accordance with Ch 9, Sec 8, [2.1.9], high-pressure alarms shall be provided for each set pressure.

4.1.4 Each cargo-pump discharge line and each liquid and vapour cargo manifold shall be provided with at least one pressure indicator.

4.1.5 Local-reading manifold pressure indication shall be provided to indicate the pressure between ship’s manifold valves and hose connections to the shore.

4.1.6 Hold spaces and interbarrier spaces without open connection to the atmosphere shall be provided with pressure indication.

4.1.7 All pressure indications provided shall be capable of indicating throughout the operating pressure range.

5 Temperature indicating devices

5.1 General

5.1.1 Each cargo tank shall be provided with at least two devices for indicating cargo temperatures, one placed at the bottom of the cargo tank and the second near the top of the tank, below the highest allowable liquid level. The lowest temperature for which the cargo tank has been designed, as shown on the International Certificate of Fitness for the Carriage of Liquefied Gases in Bulk, shall be clearly indicated by means of a sign on or near the temperature indicating devices.

5.1.2 The temperature indicating devices shall be capable of providing temperature indication across the expected cargo operating temperature range of the cargo tanks.

5.1.3 Where thermowells are fitted, they shall be designed to minimize failure due to fatigue in normal service.

6 Gas detection

6.1 General

6.1.1 Gas detection equipment shall be installed to monitor the integrity of the cargo containment, cargo handling and ancillary systems, in accordance with this section.

6.1.2 A permanently installed system of gas detection and audible and visual alarms shall be fitted in:

- a) all enclosed cargo and cargo machinery spaces (including turrets compartments) containing gas piping, gas equipment or gas consumers
- b) other enclosed or semi-enclosed spaces where cargo vapours may accumulate, including interbarrier spaces and hold spaces for independent tanks other than type C tanks
- c) airlocks
- d) spaces in gas-fired internal combustion engines, referred to in Ch 9, Sec 16, [7.8.3]
- e) ventilation hoods and gas ducts required by Ch 9, Sec 16
- f) cooling/heating circuits, as required by Ch 9, Sec 7, [8.1.1], item d)
- g) inert gas generator supply headers, and
- h) motor rooms for cargo handling machinery.

In addition, the gas detection system is also to serve spaces adjacent to pump rooms and compressor rooms.

6.1.3 Gas detection equipment shall be designed, installed and tested in accordance with recognized standards and shall be suitable for the cargoes to be carried in accordance with Ch 9, Sec 19, Tab 1, column "Vapour detection".

Note 1: IEC 60079-29-1 - Explosive atmospheres - Gas detectors - Performance requirements of detectors for flammable gases.

6.1.4 Where indicated by an "A" in Ch 9, Sec 19, Tab 1, column "Vapour detection" ships certified for carriage of non-flammable products, oxygen deficiency monitoring shall be fitted in cargo machinery spaces and hold spaces for independent tanks other than type C tanks. Furthermore, oxygen deficiency monitoring equipment shall be installed in enclosed or semi-enclosed spaces containing equipment that may cause an oxygen-deficient environment such as nitrogen generators, inert gas generators or nitrogen cycle refrigerant systems.

Two oxygen sensors are to be positioned at appropriate locations in the space or spaces containing the inert gas system, in accordance with Pt C, Ch 4, Sec 15, [13.2.4], item e) 4), for all gas carriers, irrespective of the carriage of cargo indicated by an "A" in column "f" in Ch 9, Sec 19, Tab 1.

6.1.5 In the case of toxic products or both toxic and flammable products, except when Ch 9, Sec 19, Tab 1, column "Special requirements" refers to Ch 9, Sec 17, [5.1.3], portable equipment can be used for the detection of toxic products as an alternative to a permanently installed system. This equipment shall be used prior to personnel entering the spaces listed in [6.1.2] and at 30-minute intervals while they remain in the space.

6.1.6 In the case of gases classified as toxic products, hold spaces and interbarrier spaces shall be provided with a permanently installed piping system for obtaining gas samples from the spaces. Gas from these spaces shall be sampled and analysed from each sampling head location.

6.1.7 Permanently installed gas detection shall be of the continuous detection type, capable of immediate response. Where not used to activate safety shutdown functions required by [6.1.9] and Ch 9, Sec 16, sampling type detection may be accepted.

6.1.8 When sampling type gas detection equipment is used, the following requirements shall be met:

- the gas detection equipment shall be capable of sampling and analysing for each sampling head location sequentially at intervals not exceeding 30 min
- individual sampling lines from sampling heads to the detection equipment shall be fitted, and
- pipe runs from sampling heads shall not be led through non-hazardous spaces except as permitted by [6.1.9].

6.1.9 The gas detection equipment may be located in a non-hazardous space, provided that the detection equipment such as sample piping, sample pumps, solenoids and analysing units are located in a fully enclosed steel cabinet with the door sealed by a gasket. The atmosphere within the enclosure shall be continuously monitored. At gas concentrations above 30% lower flammable limit (LFL) inside the enclosure, the gas detection equipment shall be automatically shut down.

Gas analysing units are to be in compliance with the requirements in Ch 7, Sec 6, [7.4].

6.1.10 Where the enclosure cannot be arranged directly on the forward bulkhead, sample pipes shall be of steel or equivalent material and be routed on their shortest way. Detachable connections, except for the connection points for isolating valves required in [6.1.13] and analysing units, are not permitted.

6.1.11 When gas sampling equipment is located in a non-hazardous space, a flame arrester and a manual isolating valve shall be fitted in each of the gas sampling lines. The isolating valve shall be fitted on the non-hazardous side. Bulkhead penetrations of sample pipes between hazardous and non-hazardous areas shall maintain the integrity of the division penetrated. The exhaust gas shall be discharged to the open air in a safe location.

6.1.12 In every installation, the number and the positions of detection heads shall be determined with due regard to the size and layout of the compartment, the compositions and densities of the products intended to be carried and the dilution from compartment purging or ventilation and stagnant areas.

Sampling heads in cargo holds are not to be located in positions where bilge water may collect.

6.1.13 Any alarms status within a gas detection system required by this section shall initiate an audible and visible alarm:

- on the navigation bridge
- at the relevant control station(s) where continuous monitoring of the gas levels is recorded, and
- at the gas detector readout location.

6.1.14 In the case of flammable products, the gas detection equipment provided for hold spaces and interbarrier spaces that are required to be inerted shall be capable of measuring gas concentrations of 0% to 100% by volume.

6.1.15 Alarms shall be activated when the vapour concentration by volume reaches the equivalent of 30% LFL in air.

6.1.16 For membrane containment systems, the primary and secondary insulation spaces shall be able to be inerted and their gas content analysed individually.

Note 1: Gas Concentrations in the Insulation Spaces of Membrane LNG Carriers, March 2007 (published by SIGTTO).

The alarm in the secondary insulation space shall be set in accordance with [6.1.15], that in the primary space is set at a value approved by the Society.

6.1.17 For other spaces described by [6.1.2], alarms shall be activated when the vapour concentration reaches 30% LFL and safety functions required by Ch 9, Sec 16 shall be activated before the vapour concentration reaches 60% LFL. The crankcases of internal combustion engines that can run on gas shall be arranged to alarm before 100% LFL.

6.1.18 Gas detection equipment shall be so designed that it may readily be tested. Testing and calibration shall be carried out at regular intervals. Suitable equipment for this purpose shall be carried on board and be used in accordance with the manufacturer's recommendations. Permanent connections for such test equipment shall be fitted.

6.1.19 Every ship shall be provided with at least two sets of portable gas detection equipment that meet the requirement of [6.1.3] or an acceptable national or international standard.

For ships intended to carry toxic and flammable gases, two sets for toxic gases and two sets for flammable gases are to be provided.

6.1.20 A suitable instrument for the measurement of oxygen levels in inert atmospheres shall be provided.

7 Additional requirements for containment systems requiring a secondary barrier

7.1 Integrity of barriers

7.1.1 Where a secondary barrier is required, permanently installed instrumentation shall be provided to detect when the primary barrier fails to be liquid-tight at any location or when liquid cargo is in contact with the secondary barrier at any location. This instrumentation shall consist of appropriate gas detecting devices according to [6]. However, the instrumentation need not be capable of locating the area where liquid cargo leaks through the primary barrier or where liquid cargo is in contact with the secondary barrier.

7.1.2 Upon special approval, appropriate temperature indicating devices may be accepted by the Society instead of gas detecting devices when the cargo temperature is not lower than -55°C .

7.2 Temperature indication devices

7.2.1 The number and position of temperature-indicating devices shall be appropriate to the design of the containment system and cargo operation requirements.

7.2.2 When cargo is carried in a cargo containment system with a secondary barrier, at a temperature lower than -55°C , temperature-indicating devices shall be provided within the insulation or on the hull structure adjacent to cargo containment systems. The devices shall give readings at regular intervals and, where applicable, alarm of temperatures approaching the lowest for which the hull steel is suitable.

7.2.3 The temperatures are to be continuously recorded at regular intervals. Audible and visual alarms are to be automatically activated when the hull steel temperature approaches the lowest temperature for which the steel has been approved.

7.2.4 If cargo is to be carried at temperatures lower than -55°C , the cargo tank boundaries, if appropriate for the design of the cargo containment system, shall be fitted with a sufficient number of temperature-indicating devices to verify that unsatisfactory temperature gradients do not occur.

7.2.5 For the purposes of design verification and determining the effectiveness of the initial cooldown procedure on a single or series of similar ships, one tank shall be fitted with devices in excess of those required in [7.2.1]. These devices may be temporary or permanent and only need to be fitted to the first ship, when a series of similar ships is built.

8 Automation systems

8.1 General

8.1.1

The requirements of this section shall apply where automation systems are used to provide instrumented control, monitoring/ alarm or safety functions required by this Code.

8.1.2 *Automation systems shall be designed, installed and tested in accordance with recognized standards.*

Note 1: Refer to the recommendations for computer-based systems contained in the standard published by the International Electrotechnical Commission, IEC 60092-504:2001 "Electrical installations in ships - Special features - Control and instrumentation".

8.1.3 *Hardware shall be capable of being demonstrated to be suitable for use in the marine environment by type approval or other means.*

8.1.4 *Software shall be designed and documented for ease of use, including testing, operation and maintenance.*

8.1.5 *The user interface shall be designed such that the equipment under control can be operated in a safe and effective manner at all times.*

8.1.6 *Automation systems shall be arranged such that a hardware failure or an error by the operator does not lead to an unsafe condition. Adequate safeguards against incorrect operation shall be provided.*

8.1.7 *Appropriate segregation shall be maintained between control, monitoring/alarm and safety functions to limit the effect of single failures. This shall be taken to include all parts of the automation systems that are required to provide specified functions, including connected devices and power supplies.*

8.1.8 *Automation systems shall be arranged such that the software configuration and parameters are protected against unauthorized or unintended change.*

8.1.9 *A management of change process shall be applied to safeguard against unexpected consequences of modification. Records of configuration changes and approvals shall be maintained on board.*

8.1.10 *Processes for the development and maintenance of integrated systems shall be in accordance with recognized standards. These processes shall include appropriate risk identification and management.*

Note 1: Refer to the International Electrotechnical Commission standard ISO/IEC 15288:2008 Systems and software engineering - System life cycle processes, and ISO 17894:2005 Ships and marine technology - Computer applications - General principles for the development and use of programmable electronic systems in marine applications.

9 System integration

9.1 General

9.1.1 *Essential safety functions shall be designed such that risks of harm to personnel or damage to the installation or the environment are reduced to a level acceptable to the Society, both in normal operation and under fault conditions. Functions shall be designed to fail-safe. Roles and responsibilities for integration of systems shall be clearly defined and agreed by relevant parties.*

9.1.2 *Functional requirements of each component subsystem shall be clearly defined to ensure that the integrated system meets the functional and specified safety requirements and takes account of any limitations of the equipment under control.*

9.1.3 *Key hazards of the integrated system shall be identified using appropriate risk-based techniques.*

Note 1: "Integrated system" means a combination of computer-based systems which are used for the control, monitoring/alarm and safety functions required for the carriage, handling and conditioning of cargo liquid and vapours and are interconnected in order to allow communication between computer-based systems and to allow centralized access to monitoring/alarm and safety information and/or command/control.

9.1.4 *The integrated system shall have a suitable means of reversionary control.*

9.1.5 *Failure of one part of the integrated system shall not affect the functionality of other parts, except for those functions directly dependent on the defective part.*

9.1.6 *Operation with an integrated system shall be at least as effective as it would be with individual stand-alone equipment or systems.*

9.1.7 *The integrity of essential machinery or systems, during normal operation and fault conditions, shall be demonstrated.*

Section 14 Personnel Protection

1 General

1.1 Protective equipment

1.1.1 Suitable protective equipment, including eye protection to a recognized national or international standard, shall be provided for protection of crew members engaged in normal cargo operations, taking into account the characteristics of the products being carried.

1.1.2 Personal protective and safety equipment required in this Section shall be kept in suitable, clearly marked lockers located in readily accessible places.

1.1.3 The compressed air equipment shall be inspected at least once a month by a responsible officer and the inspection logged in the ship's records. This equipment shall also be inspected and tested by a competent person at least once a year.

1.2 First-aid equipment

1.2.1 A stretcher that is suitable for hoisting an injured person from spaces below deck shall be kept in a readily accessible location.

1.2.2 The ship shall have onboard medical first-aid equipment, including oxygen resuscitation equipment, based on the requirements of the Medical First Aid Guide (MFAG) for the cargoes listed on the International Certificate of Fitness for the Carriage of Liquefied Gases in Bulk shown in Appendix 2 of the IGC Code.

1.3 Safety equipment

1.3.1 Sufficient, but not less than three complete sets of safety equipment shall be provided in addition to the firefighter's outfits required by Ch 9, Sec 11, [1.6.1]. Each set shall provide adequate personal protection to permit entry and work in a gas-filled space. This equipment shall take into account the nature of the cargoes, listed on the International Certificate of Fitness for the Carriage of Liquefied Gases in Bulk shown in Appendix 2 of the IGC Code.

1.3.2 Each complete set of safety equipment shall consist of:

- a) one self-contained positive pressure air-breathing apparatus incorporating full face mask, not using stored oxygen and having a capacity of at least 1,200 litre of free air. Each set shall be compatible with that required by Ch 9, Sec 11, [1.6.1]
- b) protective clothing, boots and gloves to a recognized standard
- c) steel-cored rescue line with belt, and
- d) explosion-proof lamp.

1.3.3 An adequate supply of compressed air shall be provided and shall consist of:

- a) at least one fully charged spare air bottle for each breathing apparatus required by [1.3.1]
- b) an air compressor of adequate capacity capable of continuous operation, suitable for the supply of high-pressure air of breathable quality, and
- c) a charging manifold capable of dealing with sufficient spare breathing apparatus air bottles for the breathing apparatus required by [1.3.1].

1.4 Personal protection requirements for individual products

1.4.1 Requirements of this section shall apply to ships carrying products for which those paragraphs are listed in Ch 9, Sec 19, Tab 1 column "Special requirements".

1.4.2 Suitable respiratory and eye protection for emergency escape purposes shall be provided for every person on board, subject to the following:

- a) filter-type respiratory protection is unacceptable
- b) self-contained breathing apparatus shall have at least a duration of service of 15 min, and
- c) emergency escape respiratory protection shall not be used for fire fighting or cargo-handling purposes and shall be marked to that effect.

1.4.3 One or more suitably marked decontamination showers and eyewash stations shall be available on deck, taking into account the size and layout of the ship. The showers and eyewashes shall be operable in all ambient conditions.

1.4.4 The showers and eye wash are to be fitted with a heating system, or other suitable installation, in order to avoid any ice formation in their piping.

1.4.5 *The protective clothing required under [1.3.2], item b), shall be gastight.*

Section 15 Filling Limits for Cargo Tanks

1 General

1.1 Definitions

1.1.1 Filling limit

Filling limit (FL) means the maximum liquid volume in a cargo tank relative to the total tank volume when the liquid cargo has reached the reference temperature.

1.1.2 Loading limit

Loading limit (LL) means the maximum allowable liquid volume relative to the tank volume to which the tank may be loaded.

1.1.3 Reference temperature

Reference temperature means (for the purposes of this Section only):

- a) *when no cargo vapour pressure/temperature control, as referred to in Ch 9, Sec 7, is provided, the temperature corresponding to the vapour pressure of the cargo at the set pressure of the PRVs, and*
- b) *when a cargo vapour pressure/temperature control, as referred to in Ch 9, Sec 7, is provided, the temperature of the cargo upon termination of loading, during transport or at unloading, whichever is the greatest.*

1.1.4 Ambient design temperature for unrestricted service

Ambient design temperature for unrestricted service means sea temperature of 32°C and air temperature of 45°C. However, lesser values of these temperatures may be accepted by the Society for ships operating in restricted areas or on voyages of restricted duration, and account may be taken in such cases of any insulation of the tanks. Conversely, higher values of these temperatures may be required for ships permanently operating in areas of high-ambient temperature.

1.2 General requirements

1.2.1 *The maximum filling limit of cargo tanks shall be so determined that the vapour space has a minimum volume at reference temperature allowing for:*

- *tolerance of instrumentation such as level and temperature gauges*
- *volumetric expansion of the cargo between the PRV set pressure and the maximum allowable rise stated in Ch 9, Sec 8, [4], and*
- *an operational margin to account for liquid drained back to cargo tanks after completion of loading, operator reaction time and closing time of valves, see Ch 9, Sec 5, [5] and Ch 9, Sec 18, [3.2.1], item d).*

1.3 Default filling limit

1.3.1 *The default value for the filling limit (FL) of cargo tanks is 98% at the reference temperature. Exceptions to this value shall meet the requirements of [1.4].*

1.4 Determination of increased filling limit

1.4.1 *A filling limit greater than the limit of 98% specified in [1.3] may be permitted under the trim and list conditions specified in Ch 9, Sec 8, [2.1.20], providing:*

- a) *no isolated vapour pockets are created within the cargo tank*
- b) *the PRV inlet arrangement shall remain in the vapour space, and*
- c) *allowances need to be provided for:*
 - *volumetric expansion of the liquid cargo due to the pressure increase from the MARVS to full flow relieving pressure in accordance with Ch 9, Sec 8, [4.1].*
 - *an operational margin of minimum 0,1% of tank volume, and*
 - *tolerances of instrumentation such as level and temperature gauges.*

1.4.2 *In no case shall a filling limit exceeding 99.5% at reference temperature be permitted.*

1.4.3 *The PRV inlet, as defined in [1.4.1], item b), is to be remain in the vapour space at a minimum distance of 40% of the diameter of the suction funnel measured at the centre of the funnel above the liquid level under conditions of 15° list and 0,015L trim.*

1.4.4 The following method may be used to determine the allowance defined in [1.4.1], item c). The Society may accept other methods to determine the allowance provided the method meets an equivalent level of safety.

The parameters specified under [1.4.1], item c) may be expressed by the expansion factor α_T , in %, to be determined as follows:

$$\alpha_T = \sqrt{\alpha_1^2 + \alpha_2^2} + \alpha_3 + \alpha_4$$

where:

α_1 : Relative increase in liquid volume, in %, due to tolerance of level gauges:

$$\alpha_1 = \frac{dV}{dh} \times \frac{\Delta h}{V} \times 100$$

where:

dV/dh : Variation of tank volume per metre filling height at the filling height h , in m^3/m

h : Filling height, in m, at the filling limit FL to be investigated (FL>98%)

V : Accepted total tank volume, in m^3

Δh : Max. total tolerance of level gauges, in m

α_2 : Relative increase in liquid volume, in %, due to the tolerance of temperature gauges:

$$\alpha_2 = \beta \Delta T$$

where:

β : volumetric thermal expansion coefficient at reference temperature, in $\%/^{\circ}K$

ΔT : max. tolerance of temperature gauge, in $^{\circ}K$

α_3 : Expansion of cargo volume, in %, due to pressure rise when pressure relief valves are relieving at maximum flow rate:

$$\alpha_3 = 100 \left(\frac{\rho_{PRV}}{\rho_{PRV1,2}} - 1 \right)$$

where:

ρ_{PRV} : cargo density at reference conditions (corresponding to the temperature of the cargo at set opening pressure of the pressure relief valve (PRV))

$\rho_{PRV1,2}$: cargo density corresponding to the temperature of the cargo at 1,2 times the set opening pressure of the pressure relief valve (PRV)

α_4 : Operational margin of 0,1%.

1.5 Maximum loading unit

1.5.1 The maximum loading limit (LL) to which a cargo tank may be loaded shall be determined by the following formula:

$$LL = FL \times \frac{\rho_R}{\rho_L}$$

where:

LL : loading limit as defined in [1.1.2], expressed in percentage

FL : filling limit as specified in [1.3] or [1.4], expressed in percentage

ρ_R : relative density of cargo at the reference temperature, and

ρ_L : relative density of cargo at the loading temperature.

1.5.2 The Society may allow type C tanks to be loaded according to the formula in [1.5.1] with the relative density ρ_R provided that the tank vent system has been approved in accordance with Ch 9, Sec 8, [2.1.21]:

Note 1: ρ_R is the relative density of cargo at the highest temperature that the cargo may reach upon termination of loading, during transport, or at unloading, under the ambient design temperature conditions described in [1.1.4].

This paragraph does not apply to products requiring a type 1G ship.

1.6 Information to be provided to the Master

1.6.1 A document shall be provided to the ship, specifying the maximum allowable loading limits for each cargo tank and product, at each applicable loading temperature and maximum reference temperature. The information in this document shall be approved by the Society.

1.6.2 Pressures at which the PRVs have been set shall also be stated in the document.

1.6.3 A copy of the above document shall be permanently kept on board by the master.

Section 16 Use of Cargo as Fuel

1 General

1.1

1.1.1 Except as provided for in [9], methane (LNG) is the only cargo whose vapour or boil-off gas may be utilized in machinery spaces of category A, and, in these spaces, it may be utilized only in systems such as boilers, inert gas generators, internal combustion engines, gas combustion unit and gas turbines.

1.1.2 Liquefied gas carriers using LPG as fuel are to comply with the requirements of Article [9].

2 Use of cargo vapour as fuel

2.1 General

2.1.1 This section addresses the use of cargo vapour as fuel in systems such as boilers, inert gas generators, internal combustion engines, gas combustion units and gas turbines.

2.1.2 For vaporized LNG, the fuel supply system shall comply with the requirements of [4.1], [4.2] and [4.3].

2.1.3 For vaporized LNG, gas consumers shall exhibit no visible flame and shall maintain the uptake exhaust temperature below 535°C.

3 Arrangement of spaces containing gas consumers

3.1 General

3.1.1 Spaces in which gas consumers are located shall be fitted with a mechanical ventilation system that is arranged to avoid areas where gas may accumulate, taking into account the density of the vapour and potential ignition sources. The ventilation system shall be separated from those serving other spaces.

3.1.2 Gas detectors shall be fitted in these spaces, particularly where air circulation is reduced. The gas detection system shall comply with the requirements of Ch 9, Sec 13.

3.1.3 Electrical equipment located in the double wall pipe or duct specified in [4.3] shall comply with the requirements of Ch 9, Sec 10.

3.1.4 All vents and bleed lines that may contain or be contaminated by gas fuel shall be routed to a safe location external to the machinery space and be fitted with a flame screen.

In case of high pressure gas supply, means are to be taken to manage the large gas influx without release to atmosphere.

4 Gas fuel supply

4.1 General

4.1.1 The requirements of this section shall apply to gas fuel supply piping outside of the cargo area. Fuel piping shall not pass through accommodation spaces, service spaces, electrical equipment rooms or control stations. The routing of the pipeline shall take into account potential hazards, due to mechanical damage, in areas such as stores or machinery handling areas.

4.1.2 Gas piping is to be installed in accordance with the requirements of Ch 9, Sec 5, [2.2].

4.1.3 Gas piping is to be suitably earthed and in accordance with the requirement of Ch 9, Sec 5, [7.4.1].

4.1.4 Piping, valves and fittings are to be hydrostatically tested, after assembly on board, to 1,5 times the working pressure but to not less than 7 bar. Subsequently, they are to be pneumatically tested to ascertain that all the joints are perfectly tight. The outer pipe or duct of double wall gas-fuel piping systems are to be in accordance with the requirement of Ch 9, Sec 5, [13.5.4].

4.1.5 Provision shall be made for inerting and gas-freeing that portion of the gas fuel piping systems located in the machinery space.

4.1.6 Classes of gas fuel piping systems

a) Purpose of the classes of piping systems

Piping systems are subdivided into three classes, denoted as class I, class II and class III, for the purpose of acceptance of materials, selection of joints, heat treatment, welding, pressure testing and the certification of fittings.

b) Determination of the classes of piping systems

Piping classes I, II and III are to be determined in accordance with the provisions of:

- Tab 1 for gas fuel piping
- Tab 2 for all vent pipes and open ended lines, including:
 - discharge lines from thermal relief valves (see Ch 9, Sec 5, [5.3.3])
 - vent lines from the gas supply lines to consumers (see [4.6.1])
 - purging lines from engines and other gas consumers.

Table 1 : Classes of gas fuel piping systems

Design conditions		Class of the gas piping		
Design pressure	Design temperature	Single wall arrangement	Double wall arrangement	
			Inner pipe	Outer pipe (1)
p = 10 bar (2)	any	Class I	Class II	Class II
p > 10 bar	any	Class I	Class I	Class II

(1) The design pressure of the outer pipe or duct of fuel systems is to comply with Ch 9, Sec 5, [4.1.4]
 (2) The design pressure is not to be taken less than 10 bar. See Ch 9, Sec 5, [4.1.1]

Table 2 : Classes of vent pipes and bleed lines

Design conditions		Class of the gas vent piping		
Vent pipe design pressure	Vent pipe design temperature	Single wall arrangement	Double wall arrangement	
			Inner pipe	Outer pipe (1)
p = 5 bar (2)	any	Class III	Class III	Class III
p > 5 bar and p ≤ 10 bar (3)	any	Class II	Class III	Class III
P > 10 bar (3)	any	Class I	Class II	Class III

(1) The design pressure of the outer pipe or duct of vent pipes or open ended lines is to comply with Ch 9, Sec 5, [4.1.4]
 (2) The design pressure of the vent pipes or open ended lines is not to be taken less than 5 bar. See Ch 9, Sec 5, [4.1.1]
 (3) The design pressure of the vent pipes or open ended lines is not to be less than the maximum expected pressure, which is to be justified

4.2 Leak detection

4.2.1 Continuous monitoring and alarms shall be provided to indicate a leak in the piping system in enclosed spaces and shut down the relevant gas fuel supply.

4.3 Routeing of fuel supply pipes

4.3.1 Fuel piping may pass through or extend into enclosed spaces other than those mentioned [4.1], provided it fulfils one of the following conditions:

- a) it is of a double-wall design with the space between the concentric pipes pressurized with inert gas at a pressure greater than the gas fuel pressure. The master gas fuel valve, as required by [4.6], closes automatically upon loss of inert gas pressure, or
- b) it is installed in a pipe or duct equipped with mechanical exhaust ventilation having a capacity of at least 30 air changes per hour and is arranged to maintain a pressure less than the atmospheric pressure. The mechanical ventilation is in accordance with Ch 9, Sec 12, as applicable. The ventilation is always in operation when there is fuel in the piping and the master gas fuel valve, as required by [4.6], closes automatically if the required air flow is not established and maintained by the exhaust ventilation system. The inlet or the duct may be from a non-hazardous machinery space, and the ventilation outlet is in a safe location.

4.3.2 The gas valve unit rooms are to be:

- a) gastight toward other enclosed spaces
- b) equipped with mechanical exhaust ventilation having a capacity of at least 30 air changes per hour and arranged to maintain a pressure less than the atmospheric pressure, and
- c) able to withstand the maximum built-up pressure arising in the room in case of a gas pipe rupture, as documented by suitable calculations taking into account the ventilation arrangements.

4.4 Requirements for gas fuel supply with pressure greater than 1 MPa

4.4.1 *Fuel delivery lines between the high-pressure fuel pumps/compressors and consumers shall be protected with a double-walled piping system capable of containing a high pressure line failure, taking into account the effects of both pressure and low temperature. A single-walled pipe in the cargo area up to the isolating valve(s) required by [4.6] is acceptable.*

4.4.2 *The arrangement in [4.3.1], item b) may also be acceptable providing the pipe or trunk is capable of containing a high pressure line failure, according to the requirements of [4.7] and taking into account the effects of both pressure and possible low temperature and providing both inlet and exhaust of the outer pipe or trunk are in the cargo area.*

4.4.3 High pressure gas piping systems are to be checked for sufficient constructive strength by carrying out stress analysis taking into account the stresses due to the weight of the piping system including acceleration load, when significant, internal pressure and loads induced by hog and sag of the ship (see also Ch 9, Sec 5, [11.4.1]).

In fuel gas piping systems of design pressure greater than the critical pressure, the tangential membrane stress of straight section of pipe or ducting is to be in accordance with requirement [11.4.1].

4.4.4 All valves and expansion joints used in high pressure gas fuel supply lines are to be of an approved type.

4.4.5 The possibility of fatigue failure of the high pressure gas piping due to vibration is to be considered.

4.4.6 The possibility of pulsation of gas fuel supply pressure caused by the high pressure gas compressor is to be considered.

4.4.7 Gas fuel piping may pass through or extend into machinery spaces or gas-safe spaces other than accommodation spaces, service spaces and control stations provided that they fulfil one of the following conditions:

- a) The system complies with [4.3.1], and in addition, with items 1) to 3) below:
 - 1) The pressure in the space between concentric pipes is monitored continuously. Alarm is to be issued and the automatic valves specified in [4.5.1] (hereafter referred to as “interlocked gas valves”) and the master gas fuel valves specified in [4.6] (hereafter referred to as “master gas valves”) are to be closed before the pressure drops to below the inner pipe pressure (however, an interlocked gas valve connected to the vent outlet is to be opened).
 - 2) The construction and strength of the outer pipes are to comply with the requirements of Ch 9, Sec 5.
 - 3) It is to be so arranged that the inside of the gas fuel supply piping system between the master gas valve and the engine is automatically purged with inert gas when the master gas valve is closed; or
- b) The system complies with [4.3.1], and, in addition, with items 1) to 4) below:
 - 1) The materials, construction and strength of protection pipes or ducts and mechanical ventilation systems are to be sufficiently durable against bursting and rapid expansion of high pressure gas in the event of gas pipe burst.
 - 2) The capacity of mechanical ventilating systems is to be determined considering the flow rate of gas fuel and construction and arrangement of protective pipes or ducts, as deemed appropriate by the Society.
 - 3) The air intakes of mechanical ventilating systems are to be provided with non-return devices effective for gas fuel leaks. However, if a gas detector is fitted at the air intakes, this requirement may be dispensed with.
 - 4) The number of flange joints of protective pipes or ducts is to be minimised; or
- c) Alternative arrangements to those given in a) and b) will be specially considered by the Society based upon an equivalent level of safety.

4.4.8 Joints on the entire length of the gas fuel supply lines are to be butt-welded joints with full penetration and to be fully radiographed, except where specially approved by the Society.

4.4.9 Pipe joints other than welded joints at the locations specifically approved by the Society are to comply with the appropriate standards recognised by the Society, or with joints whose structural strength has been verified through test analysis as deemed appropriate by the Society.

4.4.10 For all butt-welded joints of high pressure gas fuel supply lines, post-weld heat treatment is to be performed depending on the kind of material.

4.5 Gas consumer isolation

4.5.1 *The supply piping of each gas consumer unit shall be provided with gas fuel isolation by automatic double block and bleed, vented to a safe location, under both normal and emergency operation. The automatic valves shall be arranged to fail to the closed position on loss of actuating power. In a space containing multiple consumers, the shutdown of one shall not affect the gas supply to the others.*

4.5.2 The automatic double block and bleed indicated in [4.5.1] are to be capable of being manually operated.

4.5.3 It is to be possible to operate the valves indicated in [4.5.1] locally and from each control platform. They are to close automatically under the following service conditions:

- a) whenever the gas pressure varies by more than 10% or, in the case of supercharged engines, if the differential pressure between gas and charging air is no longer constant
- b) in the event of one of the following fault situations:
 - 1) gas supply to boiler burners
 - insufficient air supply for complete combustion of the gas
 - extinguishing of the pilot burner for an operating burner, unless the gas supply line to every individual burner is equipped with a quick-closing valve that automatically cuts off the gas
 - low pressure of the gas
 - 2) gas supply to internal combustion engines
 - failure of supply to pilot fuel injection pump
 - drop of engine speed below the lowest service speed.

4.6 Spaces containing gas consumers

4.6.1 *It shall be possible to isolate the gas fuel supply to each individual space containing a gas consumer(s) or through which fuel gas supply piping is run, with an individual master valve, which is located within the cargo area. The isolation of gas fuel supply to a space shall not affect the gas supply to other spaces containing gas consumers if they are located in two or more spaces, and it shall not cause loss of propulsion or electrical power.*

4.6.2 *If the double barrier around the gas supply system is not continuous due to air inlets or other openings, or if there is any point where single failure will cause leakage into the space, the individual master valve for the space shall operate under the following circumstances:*

- a) automatically, by:
 - gas detection within the space
 - leak detection in the annular space of a double-walled pipe
 - leak detection in other compartments inside the space, containing single-walled gas piping; in particular the GVU compartment
 - loss of ventilation in the annular space of a double-walled pipe, and
 - loss of ventilation in other compartments inside the space, containing single-walled gas piping, in particular the GVU compartment and
- b) manually, from within the space and at least one remote location.

4.6.3 *If the double barrier around the gas supply system is continuous, an individual master valve located in the cargo area may be provided for each gas consumer inside the space. The individual master valve shall operate under the following circumstances:*

- a) automatically, by:
 - leak detection in the annular space of a double-walled pipe served by that individual master valve
 - leak detection in other compartments containing single-walled gas piping that is part of the supply system served by the individual master valve, and
 - loss of ventilation or loss of pressure in the annular space of a double-walled pipe, and
- b) manually, from within the space and at least one remote location.

4.7 Piping and ducting construction

4.7.1 *Gas fuel piping in machinery spaces shall comply with Ch 9, Sec 5, [1] to Ch 9, Sec 5, [9], as applicable. The piping shall, as far as practicable, have welded joints. Those parts of the gas fuel piping that are not enclosed in a ventilated pipe or duct according to [4.3], and are on the weather decks outside the cargo area, shall have full penetration butt-welded joints and shall be fully radiographed.*

4.8 Gas detection

4.8.1 Gas detection systems provided in accordance with the requirements of this Section shall activate the alarm at 30% LFL and shut down the master gas fuel valve required by [7.5] at not more than 60% LFL (see Ch 9, Sec 13, [6.1.17]).

5 Gas fuel plant and related storage tanks

5.1 Provision of gas fuel

5.1.1 All equipment (heaters, compressors, vaporizers, filters, etc.) for conditioning the cargo and/or cargo boil off vapour for its use as fuel, and any related storage tanks, shall be located in the cargo area. If the equipment is in an enclosed space, the space shall be ventilated according to Ch 9, Sec 12, [1.2] and be equipped with a fixed fire-extinguishing system, according to Ch 9, Sec 11, [1.5], and with a gas detection system according to Ch 9, Sec 13, [6], as applicable.

5.1.2 Means for purging of flammable gases before opening are to be provided in the equipment for making up gas.

5.1.3 Where the equipment (heaters, compressors, filters) for making up the gas for its use as fuel and the storage tanks are located on the weather deck, they are to be suitably protected from atmospheric agents and the sea.

5.2 Remote stops

5.2.1 All rotating equipment utilized for conditioning the cargo for its use as fuel shall be arranged for manual remote stop from the engine-room. Additional remote stops shall be located in areas that are always easily accessible, typically cargo control room, navigation bridge and fire control station.

5.2.2 The fuel supply equipment shall be automatically stopped in the case of low suction pressure or fire detection. Unless expressly provided otherwise, the requirements of Ch 9, Sec 18, [3] need not apply to gas fuel compressors or pumps when used to supply gas consumers.

- a) The compressors are to be capable of being remotely stopped from an always and easily accessible, non-dangerous position in the open, and also from the engine room.
- b) In addition, the compressors are to be capable of automatically stopping when the suction pressure reaches a certain value depending on the setting pressure of the vacuum relief valves of the cargo tanks.
- c) The automatic shutdown device of the compressors is to have a manual resetting.

5.3 Compressors

5.3.1 Miscellaneous requirements

- a) Low pressure piston-type compressors are to be fitted with relief valves discharging to a position in the open, such as not to give rise to hazards.
- b) Volumetric compressors are to be fitted with pressure/vacuum relief valves discharging into the suction line of the compressor.
- c) The size of the pressure relief valves is to be determined in such a way that, with the delivery valve kept closed, the maximum pressure does not exceed the maximum working pressure by more than 10%.
- d) The compressors are to be automatically stopped by the emergency shutdown system of the cargo valves.
- e) The compressors are to be fitted with shut-off valves and flame screens on both the suction and delivery sides.

5.4 Heating and cooling mediums

5.4.1 If the heating or cooling medium for the gas fuel conditioning system is returned to spaces outside the cargo area, provisions shall be made to detect and alarm the presence of cargo/cargo vapour in the medium. Any vent outlet shall be in a safe position and fitted with an effective flame screen of an approved type.

- a) Operation of the heaters is to be automatically regulated depending on the gas temperature at the heater outlet.
- b) Before it is returned to the machinery space, the heating medium (steam or hot water) is to go through a degassing tank located in the cargo area.
- c) The vent outlet is to be in a safe position, having regards of source of ignition and fitted with a flame screen.

5.5 Piping and pressure vessels

5.5.1 Piping or pressure vessels fitted in the gas fuel supply system shall comply with Ch 9, Sec 5

6 Special requirements for main boilers

6.1 Arrangements

6.1.1 *Each boiler shall have a separate exhaust uptake.*

6.1.2 *Each boiler shall have a dedicated forced draught system. A crossover between boiler force draught systems may be fitted for emergency use providing that any relevant safety functions are maintained.*

6.1.3 Boilers are to be located as high as possible in boiler spaces and are to be of the membrane wall type or equivalent, so as to create a space with forced air circulation between the membrane wall and the boiler casing.

6.1.4 *Combustion chambers and uptakes of boilers shall be designed to prevent any accumulation of gaseous fuel.*

6.1.5 The Society may, at its discretion, require gas detectors to be fitted in those combustion chamber areas where gas could accumulate, as well as the provision of suitable air nozzles.

6.2 Combustion equipment

6.2.1 *The burner systems shall be of dual type, suitable to burn either: oil fuel or gas fuel alone, or oil and gas fuel simultaneously.*

6.2.2 *Burners shall be designed to maintain stable combustion under all firing conditions.*

6.2.3 *An automatic system shall be fitted to change over from gas fuel operation to oil fuel operation without interruption of the boiler firing, in the event of loss of gas fuel supply.*

6.2.4 *Gas nozzles and the burner control system shall be configured such that gas fuel can only be ignited by an established oil fuel flame, unless the boiler and combustion equipment is designed and approved by the Society to light on gas fuel.*

6.3 Safety

6.3.1 *There shall be arrangements to ensure that gas fuel flow to the burner is automatically cut-off, unless satisfactory ignition has been established and maintained.*

6.3.2 *On the pipe of each gas-burner, a manually operated shut-off valve shall be fitted.*

6.3.3 *Provisions shall be made for automatically purging the gas supply piping to the burners, by means of an inert gas, after the extinguishing of these burners.*

6.3.4 A mechanical device is to be installed to prevent the gas valve from opening until the air and the fuel oil controls are in the ignition position. A flame screen, which may be incorporated in the burner, is to be fitted on the pipe of each gas burner.

6.3.5 *The automatic fuel changeover system required by [6.2.3] shall be monitored with alarms to ensure continuous availability.*

6.3.6 *Arrangements shall be made that, in case of flame failure of all operating burners, the combustion chambers of the boilers are automatically purged before relighting.*

6.3.7 *Arrangements shall be made to enable the boilers to be manually purged.*

7 Special requirements for gas-fired internal combustion engines

7.1 General

7.1.1 *Dual fuel engines are those that employ gas fuel (with pilot oil) and oil fuel. Oil fuels may include distillate and residual fuels. Gas only engines are those that employ gas fuel only.*

7.2 Gas fuel supply to engines with fuel injection pressure greater than 1 MPa

7.2.1 Flame arresters are to be provided at the inlet to the gas supply manifold for the engine.

7.2.2 Arrangements are to be made so that the gas supply to the engine can be shut off manually from the starting platform or any other control position.

7.2.3 The arrangement and installation of the gas piping are to provide the necessary flexibility for the gas supply piping to accommodate the oscillating movements of the engines without risk of fatigue failure.

7.2.4 The connecting of gas line and protection pipes or ducts as per [4.2.1] to the gas fuel injection valves is to provide complete coverage by the protection pipe or ducts.

7.3 Shut-off of gas fuel supply with pressure greater than 1 MPa

7.3.1 Fuel supply shut-off

In addition to the causes specified in [4.5.1], supply of gas fuel to engines is to be shut-off by the interlocked gas valves in the event of the following abnormalities:

- a) abnormality specified in Pt C, Ch 1, App 2
- b) engine stops due to any cause.

7.3.2 Master gas valve shut-off

In addition to the causes specified in [4.6], the master gas valve is to be closed in the event of any of the following:

- a) the oil mist detector or bearing temperature detector specified in Pt C, Ch 1, App 2 detects abnormality
- b) any kind of gas fuel leakage is detected
- c) abnormality specified in Pt C, Ch 1, App 2.

7.3.3 Automatic operation

The master gas valve is to close automatically upon activation of the interlocked gas valves.

7.4 Emergency stop of dual fuel engines with fuel injection pressure greater than 1 MPa

7.4.1 Dual fuel engines are to be stopped before the gas concentration detected by the gas detectors specified in [3.1.2] reaches 60% of the lower flammable limit.

7.5 Requirements on dual fuel engines

7.5.1 Specific requirements on internal combustion engines supplied by gas are given in Pt C, Ch 1, App 2.

7.6 Arrangements

7.6.1 *When gas is supplied in a mixture with air through a common manifold, flame arrestors shall be installed before each cylinder head.*

7.6.2 *Each engine shall have its own separate exhaust.*

7.6.3 *The exhausts shall be configured to prevent any accumulation of unburnt gaseous fuel.*

7.6.4 *Unless designed with the strength to withstand the worst case overpressure due to ignited gas leaks, air inlet manifolds, scavenge spaces, exhaust system and crank cases shall be fitted with suitable pressure relief systems. Pressure relief systems shall lead to a safe location, away from personnel.*

A suitable pressure relief system for air inlet manifolds, scavenge spaces and exhaust system is to be provided unless designed to accommodate the worst-case overpressure due to ignited gas leaks or justified by the safety concept of the engine. A detailed evaluation regarding the hazard potential of overpressure in air inlet manifolds, scavenge spaces and exhaust system is to be carried out and reflected in the safety concept of the engine.

In the case of crankcases, the explosion relief valves, as required by Regulation 27.4 of SOLAS Chapter II-1 as amended by IMO resolutions up to MSC.436(99), are to be considered suitable for the gas operation of the engine. For engines not covered by said Regulation, a detailed evaluation regarding the hazard potential of fuel gas accumulation in the crankcase is to be carried out.

7.6.5 *Each engine shall be fitted with vent systems independent of other engines for crankcases, sumps and cooling systems.*

7.7 Combustion equipment

7.7.1 *Prior to admission of gas fuel, correct operation of the pilot oil injection system on each unit shall be verified.*

7.7.2 *For a spark ignition engine, if ignition has not been detected by the engine monitoring system within an engine specific time after opening of the gas supply valve, this shall be automatically shut off and the starting sequence terminated. It shall be ensured that any unburnt gas mixture is purged from the exhaust system.*

7.7.3 *For dual-fuel engines fitted with a pilot oil injection system, an automatic system shall be fitted to change over from gas fuel operation to oil fuel operation with minimum fluctuation of the engine power.*

7.7.4 *In the case of unstable operation on engines with the arrangement in [7.7.3] when gas firing, the engine shall automatically change to oil fuel mode.*

7.8 Safety

7.8.1 *During stopping of the engine, the gas fuel shall be automatically shut off before the ignition source.*

7.8.2 *Arrangements shall be provided to ensure that there is no unburnt gas fuel in the exhaust gas system prior to ignition.*

7.8.3 Crankcases, sumps, scavenge spaces and cooling system vents shall be provided with gas detection (see Ch 9, Sec 13, [6.1.17]).

7.8.4 Provision shall be made within the design of the engine to permit continuous monitoring of possible sources of ignition within the crank case. Instrumentation fitted inside the crankcase shall be in accordance with the requirements of Ch 9, Sec 10.

7.8.5 Means shall be provided to monitor and detect poor combustion or misfiring that may lead to unburnt gas fuel in the exhaust system during operation. In the event that it is detected, the gas fuel supply shall be shut down. Instrumentation fitted inside the exhaust system shall be in accordance with the requirements of Ch 9, Sec 10.

8 Special requirements for gas turbine

8.1 Arrangements

8.1.1 Each turbine shall have its own separate exhaust.

8.1.2 The exhausts shall be appropriately configured to prevent any accumulation of unburnt gas fuel.

8.1.3 Unless designed with the strength to withstand the worst case overpressure due to ignited gas leaks, pressure relief systems shall be suitably designed and fitted to the exhaust system, taking into consideration explosions due to gas leaks. Pressure relief systems within the exhaust uptakes shall be lead to a non-hazardous location, away from personnel.

8.2 Combustion equipment

8.2.1 An automatic system shall be fitted to change over easily and quickly from gas fuel operation to oil fuel operation with minimum fluctuation of the engine power.

8.3 Safety

8.3.1 Means shall be provided to monitor and detect poor combustion that may lead to unburnt gas fuel in the exhaust system during operation. In the event that it is detected, the gas fuel supply shall be shut down.

8.3.2 Each turbine shall be fitted with an automatic shutdown device for high exhaust temperatures.

9 Alternative fuels and technologies

9.1 General

9.1.1 If acceptable to the Society, other cargo gases may be used as fuel, providing that the same level of safety as natural gas in this Code is ensured.

9.1.2 The use of cargoes identified as toxic products shall not be permitted.

9.1.3 For cargoes other than LNG, the fuel supply system shall comply with the requirements of [4.1], [4.2], [4.3] and [5], as applicable, and shall include means for preventing condensation of vapour in the system.

9.1.4 Liquefied gas fuel supply systems shall comply with [4.5].

9.1.5 In addition to the requirements of [4.3.1], item b), both ventilation inlet and outlet shall be located outside the machinery space. The inlet shall be in a non-hazardous area and the outlet shall be in a safe location.

Section 17 Special Requirements

1 General

1.1 Application

1.1.1 *The requirements of this Section are applicable where reference thereto is made in Ch 9, Sec 19, Tab 1, column “Special requirements”.*

These requirements are additional to the general requirements of this Chapter.

2 Materials of construction

2.1 General

2.1.1 *Materials that may be exposed to cargo during normal operations shall be resistant to the corrosive action of the gases. In addition, the following materials of construction for cargo tanks and associated pipelines, valves, fittings and other items of equipment normally in direct contact with the cargo liquid or vapour shall not be used for certain products as specified in Ch 9, Sec 19, Tab 1, column “Special requirements”:*

- a) *mercury, copper and copper-bearing alloys, and zinc*
- b) *copper, silver, mercury, magnesium and other acetylide-forming metals*
- c) *aluminium and aluminium-bearing alloys*
- d) *copper, copper alloys, zinc and galvanized steel*
- e) *aluminium, copper and alloys of either, and*
- f) *copper and copper-bearing alloys with greater than 1% copper.*

Materials “exposed to cargo” are those constituting systems, cargo appliances or arrangements which are in contact with (liquid or vapour) cargo in normal operating conditions.

3 Independent tanks

3.1 General

3.1.1 *Products shall be carried in independent tanks only.*

3.1.2 *Products shall be carried in type C independent tanks, and the requirements of Ch 9, Sec 7, [1.1.2] shall apply. The design pressure of the cargo tank shall take into account any padding pressure or vapour discharge unloading pressure.*

4 Refrigeration systems

4.1 General

4.1.1 *Only the indirect system described in Ch 9, Sec 7, [3.1.3], item b) shall be used.*

4.1.2 *For a ship engaged in the carriage of products that readily form dangerous peroxides, recondensed cargo shall not be allowed to form stagnant pockets of uninhibited liquid. This may be achieved either by:*

- a) *using the indirect system described in Ch 9, Sec 7, [3.1.3], item b), with the condenser inside the cargo tank, or*
- b) *using the direct system or combined system described in Ch 9, Sec 7, [3.1.3], item a) and in Ch 9, Sec 7, [3.1.3], item c) respectively, or the indirect system described in Ch 9, Sec 7, [3.1.3], item b) with the condenser outside the cargo tank, and designing the condensate system to avoid any places in which liquid could collect and be retained. Where this is impossible, inhibited liquid shall be added upstream of such a place.*

4.1.3 *If the ship is to consecutively carry products as specified in [4.1.2] with a ballast passage between, all uninhibited liquid shall be removed prior to the ballast voyage. If a second cargo is to be carried between such consecutive cargoes, the reliquefaction system shall be thoroughly drained and purged before loading the second cargo. Purging shall be carried out using either inert gas or vapour from the second cargo, if compatible. Practical steps shall be taken to ensure that polymers or peroxides do not accumulate in the cargo system.*

5 Cargoes requiring type 1G ship

5.1 General

- 5.1.1** All butt-welded joints in cargo piping exceeding 75 mm in diameter shall be subject to 100% radiography.
- 5.1.2** Gas sampling lines shall not be led into or through non-hazardous areas. Alarms referred to in Ch 9, Sec 13, [6.1.2] shall be activated when the vapour concentration reaches the threshold limiting value.
- 5.1.3** The alternative of using portable gas detection equipment in accordance with Ch 9, Sec 13, [6.1.5] shall not be permitted.
- 5.1.4** Cargo control rooms shall be located in a non-hazardous area and, additionally, all instrumentation shall be of the indirect type.
- 5.1.5** Personnel shall be protected against the effects of a major cargo release by the provision of a space within the accommodation area that is designed and equipped to the satisfaction of the Society.
- 5.1.6** Notwithstanding the requirements in Ch 9, Sec 3, [1.2.5], access to forecastle spaces shall not be permitted through a door facing the cargo area, unless airlock in accordance with Ch 9, Sec 3, [1.6] is provided.
- 5.1.7** Notwithstanding the requirements in Ch 9, Sec 3, [1.2.13], access to control rooms and machinery spaces of turret systems shall not be permitted through doors facing the cargo area.

6 Exclusion of air from vapour spaces

6.1 General

- 6.1.1** Air shall be removed from cargo tanks and associated piping before loading and, then, subsequently excluded by:
- introducing inert gas to maintain a positive pressure. Storage or production capacity of the inert gas shall be sufficient to meet normal operating requirements and relief valve leakage. The oxygen content of inert gas shall, at no time, be greater than 0.2% by volume, or
 - control of cargo temperatures such that a positive pressure is maintained at all times.

7 Moisture control

7.1 General

7.1.1 For gases that are non-flammable and may become corrosive or react dangerously with water, moisture control shall be provided to ensure that cargo tanks are dry before loading and that, during discharge, dry air or cargo vapour is introduced to prevent negative pressures. For the purposes of this paragraph, dry air is air that has a dew point of -45°C or below at atmospheric pressure.

8 Inhibition

8.1 General

- 8.1.1** Care shall be taken to ensure that the cargo is sufficiently inhibited to prevent self-reaction (e.g. polymerization or dimerization) at all times during the voyage. Ships shall be provided with a certificate from the manufacturer stating:
- name and amount of inhibitor added
 - As an alternative to the addition of inhibited liquid, it may be accepted that, at the end of each refrigeration period, the liquid is completely removed from the refrigeration system by means of vapour from compressors or by means of inert gas. In such case, the following wording is to be entered on the Certificate of Fitness:
"At the end of each refrigeration period, the liquid is to be completely removed from the refrigeration system by means of vapour from compressors or by means of inert gas."
 - On the cargo compressor delivery side, a temperature switch is to be fitted, set at a suitable temperature, depending on the characteristics of the product carried (e.g. 60°C for butadiene), giving a visual and audible alarm on the navigation bridge and in the cargo control station, if any, which causes the compressor to stop when such temperature is exceeded.
 - date inhibitor was added and the normally expected duration of its effectiveness
 - any temperature limitations affecting the inhibitor, and
 - the action to be taken should the length of the voyage exceed the effective lifetime of the inhibitors.

9 Flame screens on vent outlets

9.1 General

9.1.1 When carrying a cargo referenced to this section, cargo tank vent outlets shall be provided with readily renewable and effective flame screens or safety heads of an approved type. Due attention shall be paid in the design of flame screens and vent heads, to the possibility of the blockage of these devices by the freezing of cargo vapour or by icing up in adverse weather conditions. Flame screens shall be removed and replaced by protection screens, in accordance with Ch 9, Sec 8, [2.1.18], when carrying cargoes not referenced to this section.

10 Maximum allowable quantity of cargo per tank

10.1 General

10.1.1 When carrying a cargo referenced to this section, the quantity of the cargo shall not exceed 3,000 m³ in any one tank.

11 Cargo pumps and discharge arrangements

11.1 General

11.1.1 The vapour space of cargo tanks equipped with submerged electric motor pumps shall be inerted to a positive pressure prior to loading, during carriage and during unloading of flammable liquids.

11.1.2 The cargo shall be discharged only by deepwell pumps or by hydraulically operated submerged pumps. These pumps shall be of a type designed to avoid liquid pressure against the shaft gland.

11.1.3 Inert gas displacement may be used for discharging cargo from type C independent tanks, provided the cargo system is designed for the expected pressure.

12 Ammonia

12.1 General

12.1.1 Anhydrous ammonia may cause stress corrosion cracking in containment and process systems made of carbon-manganese steel or nickel steel. To minimize the risk of this occurring, measures detailed in [12.1.2] to [12.1.8] shall be taken, as appropriate.

12.1.2 Where carbon-manganese steel is used, cargo tanks, process pressure vessels and cargo piping shall be made of fine-grained steel with a specified minimum yield strength not exceeding 355 N/mm², and with an actual yield strength not exceeding 440 N/mm². One of the following constructional or operational measures shall also be taken:

- a) lower strength material with a specified minimum tensile strength not exceeding 410 N/mm² shall be used, or
- b) cargo tanks, etc., shall be post-weld stress relief heat treated, or
- c) carriage temperature shall be maintained, preferably at a temperature close to the product's boiling point of – 33°C, but in no case at a temperature above – 20°C, or
- d) the ammonia shall contain not less than 0.1% w/w water, and the master shall be provided with documentation confirming this.

12.1.3 If carbon-manganese steels with higher yield properties are used other than those specified in [12.1.2], the completed cargo tanks, piping, etc., shall be given a post-weld stress relief heat treatment.

12.1.4 Process pressure vessels and piping of the condensate part of the refrigeration system shall be given a post-weld stress relief heat treatment when made of materials mentioned in [12.1.1].

12.1.5 The tensile and yield properties of the welding consumables shall exceed those of the tank or piping material by the smallest practical amount.

12.1.6 Nickel steel containing more than 5% nickel and carbon-manganese steel, not complying with the requirements of [12.1.2] and [12.1.3], are particularly susceptible to ammonia stress corrosion cracking and shall not be used in containment and piping systems for the carriage of this product.

12.1.7 Nickel steel containing not more than 5% nickel may be used, provided the carriage temperature complies with the requirements specified in [12.1.2], item c).

12.1.8 To minimize the risk of ammonia stress corrosion cracking, it is advisable to keep the dissolved oxygen content below 2.5 ppm w/w. This can best be achieved by reducing the average oxygen content in the tanks prior to the introduction of liquid ammonia to less than the values given as a function of the carriage temperature *T* in Tab 1:

Table 1 : Oxygen content

T (°C)	O ₂ (% v/v)
– 30 and below	0,90
– 20	0,50
– 10	0,28
0	0,16
10	0,10
20	0,05
30	0,03

Note 1: Oxygen percentages for intermediate temperatures may be obtained by direct interpolation

13 Chlorine

13.1 Cargo containment system

13.1.1 The capacity of each tank shall not exceed 600 m³ and the total capacity of all cargo tanks shall not exceed 1200 m³.

13.1.2 The tank design vapour pressure shall not be less than 1,35 MPa (see Ch 9, Sec 7, [1.1.2] and [3.1.2]).

13.1.3 Parts of tanks protruding above the upper deck shall be provided with protection against thermal radiation, taking into account total engulfment by fire.

13.1.4 Each tank shall be provided with two PRVs. A bursting disc of appropriate material shall be installed between the tank and the PRVs. The rupture pressure of the bursting disc shall be 0,1 MPa lower than the opening pressure of the pressure relief valve, which shall be set at the design vapour pressure of the tank but not less than 1,35 MPa gauge. The space between the bursting disc and the relief valve shall be connected through an excess flow valve to a pressure gauge and a gas detection system. Provisions shall be made to keep this space at or near the atmospheric pressure during normal operation.

Chlorine discharge from pressure relief valves is to be led to an absorption device deemed suitable by the Society.

13.1.5 Outlets from PRVs shall be arranged in such a way as to minimize the hazards on board the ship as well as to the environment. Leakage from the relief valves shall be led through the absorption plant to reduce the gas concentration as far as possible. The relief valve exhaust line shall be arranged at the forward end of the ship to discharge outboard at deck level with an arrangement to select either port or starboard side, with a mechanical interlock to ensure that one line is always open.

13.1.6 The Society and the port Administration may require that chlorine is carried in a refrigerated state at a specified maximum pressure.

13.2 Cargo piping systems

13.2.1 Cargo discharge shall be performed by means of compressed chlorine vapour from shore, dry air or another acceptable gas, or fully submerged pumps. Cargo discharge compressors on board ships shall not be used for this. The pressure in the vapour space of the tank during discharging shall not exceed 1,05 MPa gauge.

13.2.2 The design pressure of the cargo piping system shall be not less than 2,1 MPa gauge. The internal diameter of the cargo pipes shall not exceed 100 mm. Only pipe bends shall be accepted for compensation of pipeline thermal movement. The use of flanged joints shall be restricted to a minimum and, when used, the flanges shall be of the welding neck type with tongue and groove.

13.2.3 A welding neck type flange deemed suitable is shown in Fig 1 as an example.

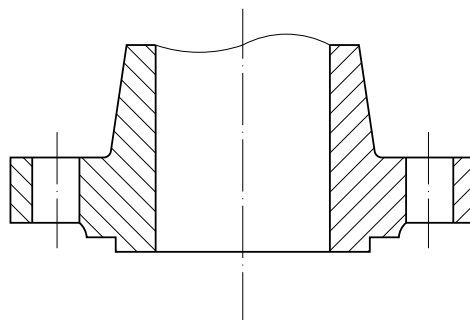
Figure 1 : Suitable neck type flange

13.2.4

Relief valves of the cargo piping system shall discharge to the absorption plant, and the flow restriction created by this unit shall be taken into account when designing the relief valve system (see Ch 9, Sec 8, [4.3] and Ch 9, Sec 8, [4.4]).

13.3 Materials

13.3.1 The cargo tanks and cargo piping systems shall be made of steel suitable for the cargo and for a temperature of -40°C , even if a higher transport temperature is intended to be used.

13.3.2 The tanks shall be thermally stress relieved. Mechanical stress relief shall not be accepted as an equivalent.

13.4 Instrumentation: safety devices

13.4.1 The ship shall be provided with a chlorine absorbing plant with a connection to the cargo piping system and the cargo tanks. The absorbing plant shall be capable of neutralizing at least 2% of the total cargo capacity at a reasonable absorption rate.

13.4.2 During the gas-freeing of cargo tanks, vapours shall not be discharged to the atmosphere.

13.4.3 A gas detecting system shall be provided that is capable of monitoring chlorine concentrations of at least 1 ppm by volume. Sample points shall be located:

- near the bottom of the hold spaces
- in the pipes from the safety relief valves
- at the outlet from the gas absorbing plant
- at the inlet to the ventilation systems for the accommodation, service and machinery spaces and control stations, and
- on deck - at the forward end, midships and the after end of the cargo area. This is only required to be used during cargo handling and gas-freeing operations.

The gas detection system shall be provided with an audible and visual alarm with a set point of 5 ppm.

The gas detection system is to be permanently installed.

13.4.4 Each cargo tank shall be fitted with a high-pressure alarm giving an audible alarm at a pressure equal to 1,05 MPa gauge.

13.5 Personnel protection

13.5.1 The enclosed space required by [5.1.5] shall meet the following requirements:

- the space shall be easily and quickly accessible from the weather decks and from accommodation spaces by means of air locks, and shall be capable of being rapidly closed gastight
- one of the decontamination showers required by Ch 9, Sec 14, [1.4.3] shall be located near the weather deck airlock to the space
- the space shall be designed to accommodate the entire crew of the ship and be provided with a source of uncontaminated air for a period of not less than 4 h, and
- one set of oxygen therapy equipment shall be carried in the space.

In addition to the source of uncontaminated air, two complete and independent air breathing apparatuses, not employing oxygen supplies, each having a capacity of at least 1200 litres of non-compressed air and two sets of protective equipment, complete with gas-tight boots, gloves and eye protection, are to be provided. The above-mentioned equipment and clothing are to be kept in the space indicated above and are additional to those required in other parts of this Chapter.

13.6 Filling limits for cargo tanks

13.6.1 The requirements of Ch 9, Sec 15, [1.1.3], item b) do not apply when it is intended to carry chlorine.

13.6.2 When determining the filling limits of the cargo tanks for the transport of chlorine, the effect of the refrigeration plant is not to be considered.

13.6.3 The chlorine content of the gas in the vapour space of the cargo tank after loading shall be greater than 80% by volume.

14 Ethylene oxide

14.1 General

14.1.1 For the carriage of ethylene oxide, the requirements of [18] shall apply, with the additions and modifications as given in this sub-article.

14.1.2 Deck tanks shall not be used for the carriage of ethylene oxide.

14.1.3 Stainless steels types 416 and 442, as well as cast iron, shall not be used in ethylene oxide cargo containment and piping systems.

14.1.4 Before loading, tanks shall be thoroughly and effectively cleaned to remove all traces of previous cargoes from tanks and associated pipework, except where the immediate prior cargo has been ethylene oxide, propylene oxide or mixtures of these products. Particular care shall be taken in the case of ammonia in tanks made of steel other than stainless steel.

14.1.5 Ethylene oxide shall be discharged only by deepwell pumps or inert gas displacement. The arrangement of pumps shall comply with [18.1.15].

14.1.6 Ethylene oxide shall be carried refrigerated only and maintained at temperatures of less than 30°C.

14.1.7 PRVs shall be set at a pressure of not less than 0,55 MPa gauge. The maximum set pressure shall be specially approved by the Society.

14.1.8 The protective padding of nitrogen gas, as required by [18.1.27], shall be such that the nitrogen concentration in the vapour space of the cargo tank will, at no time, be less than 45% by volume.

14.1.9 Before loading, and at all times when the cargo tank contains ethylene oxide liquid or vapour, the cargo tank shall be inerted with nitrogen.

14.1.10 The water-spray system required by [18.1.29] and that required by Ch 9, Sec 11, [1.3] shall operate automatically in a fire involving the cargo containment system.

14.1.11 A jettisoning arrangement shall be provided to allow the emergency discharge of ethylene oxide in the event of uncontrollable self-reaction.

15 Separate piping systems

15.1 General

15.1.1 Separate piping systems, as defined in Ch 9, Sec 1, [4.1.45], shall be provided.

16 Methyl acetylene-propadiene mixtures

16.1 General

16.1.1 Methyl acetylene-propadiene mixtures shall be suitably stabilized for transport. Additionally, upper limits of temperatures and pressure during the refrigeration shall be specified for the mixtures.

16.1.2 Examples of acceptable stabilized compositions are:

- Composition 1:
 - maximum methyl acetylene to propadiene molar ratio of 3 to 1
 - maximum combined concentration of methyl acetylene and propadiene of 65 mol%
 - minimum combined concentration of propane, butane, and isobutane of 24 mol%, of which at least one third (on a molar basis) shall be butanes and one third propane,
 - maximum combined concentration of propylene and butadiene of 10 mol%.
- Composition 2:
 - maximum methylacetylene and propadiene combined concentration of 30 mol%
 - maximum methyl acetylene concentration of 20 mol%
 - maximum propadiene concentration of 20 mol%
 - maximum propylene concentration of 45 mol%
 - maximum butadiene and butylenes combined concentration of 2 mol%
 - minimum saturated C4 hydrocarbon concentration of 4 mol%, and
 - minimum propane concentration of 25 mol%.

16.1.3 Other compositions may be accepted, provided the stability of the mixture is demonstrated to the satisfaction of the Society.

16.1.4 If a ship has a direct vapour compression refrigeration system, this shall comply with the following requirements, subject to pressure and temperature limitations depending on the composition. For the example compositions given in [16.1.2], the following features shall be provided:

- a) vapour compressor that does not raise the temperature and pressure of the vapour above 60°C and 1,75 MPa gauge during its operation, and that does not allow vapour to stagnate in the compressor while it continues to run

- b) discharge piping from each compressor stage or each cylinder in the same stage of a reciprocating compressor shall have:
- 1) two temperature-actuated shutdown switches set to operate at 60°C or less
 - 2) a pressure-actuated shutdown switch set to operate at 1,75 MPa gauge or less, and
 - 3) a safety relief valve set to relieve at 1,8 MPa gauge or less;
- c) the relief valve required by [16.1.4], item b), 3). shall vent to a mast meeting the requirements of Ch 9, Sec 8, [2.1.10], Ch 9, Sec 8, [2.1.14] and Ch 9, Sec 8, [2.1.18] and shall not relieve into the compressor suction line, and
- d) an alarm that sounds in the cargo control position and in the navigation bridge when a high-pressure switch, or a high-temperature switch, operates.

16.1.5 The piping system, including the cargo refrigeration system, for tanks to be loaded with methyl acetylene-propadiene mixtures shall be either independent (as defined in Ch 9, Sec 1, [4.1.28]) or separate (as defined in Ch 9, Sec 1, [4.1.45]) from piping and refrigeration systems for other tanks. This segregation shall apply to all liquid and vapour vent lines and any other possible connections, such as common inert gas supply lines.

17 Nitrogen

17.1 General

17.1.1 Materials of construction and ancillary equipment such as insulation shall be resistant to the effects of high oxygen concentrations caused by condensation and enrichment at the low temperatures attained in parts of the cargo system. Due consideration shall be given to ventilation in areas where condensation might occur, to avoid the stratification of oxygen-enriched atmosphere.

18 Propylene oxide and mixtures of ethylene oxide-propylene oxide with ethylene oxide content of not more than 30% by weight

18.1 General

18.1.1 Products transported under the provisions of this sub-article shall be acetylene-free.

18.1.2 Unless cargo tanks are properly cleaned, these products shall not be carried in tanks that have contained as one of the three previous cargoes any product known to catalyse polymerization, such as:

- anhydrous ammonia and ammonia solutions
- amines and amine solutions, and
- oxidizing substances (e.g. chlorine).

18.1.3 Before loading, tanks shall be thoroughly and effectively cleaned to remove all traces of previous cargoes from tanks and associated pipework, except where the immediate prior cargo has been propylene oxide or ethylene oxide-propylene oxide mixtures. Particular care shall be taken in the case of ammonia in tanks made of steel other than stainless steel.

18.1.4 In all cases, the effectiveness of cleaning procedures for tanks and associated pipework shall be checked, by suitable testing or inspection, to ascertain that no traces of acidic or alkaline materials remain that might create a hazardous situation in the presence of these products.

18.1.5 Tanks shall be entered and inspected prior to each initial loading of these products to ensure freedom from contamination, heavy rust deposits and any visible structural defects. When cargo tanks are in continuous service for these products, such inspections shall be performed at intervals of not more than two years.

18.1.6 Tanks for the carriage of these products shall be of steel or stainless steel construction.

18.1.7 Tanks that have contained these products may be used for other cargoes after thorough cleaning of tanks and associated pipework systems by washing or purging.

18.1.8 All valves, flanges, fittings and accessory equipment shall be of a type suitable for use with these products and shall be constructed of steel or stainless steel in accordance with recognized standards. Disc or disc faces, seats and other wearing parts of valves shall be made of stainless steel containing not less than 11% chromium.

18.1.9 Gaskets shall be constructed of materials which do not react with, dissolve in, or lower the auto-ignition temperature of, these products and which are fire-resistant and possess adequate mechanical behaviour. The surface presented to the cargo shall be polytetrafluoroethylene (PTFE) or materials giving a similar degree of safety by their inertness. Spirally-wound stainless steel with a filler of PTFE or similar fluorinated polymer may be accepted, if approved by the Society.

18.1.10 Insulation and packing, if used, shall be of a material which does not react with, dissolve in, or lower the auto-ignition temperature of, these products.

- 18.1.11** The following materials are generally found unsatisfactory for use in gaskets, packing and similar uses in containment systems for these products and would require testing before being approved:
- neoprene or natural rubber, if it comes into contact with the products
 - asbestos or binders used with asbestos, and
 - materials containing oxides of magnesium, such as mineral wools.
- 18.1.12** Filling and discharge piping shall extend to within 100 mm of the bottom of the tank or any sump.
- 18.1.13** The products shall be loaded and discharged in such a manner that venting of the tanks to atmosphere does not occur. If vapour return to shore is used during tank loading, the vapour return system connected to a containment system for the product shall be independent of all other containment systems.
- 18.1.14** During discharging operations, the pressure in the cargo tank shall be maintained above 0,007 MPa gauge.
- 18.1.15** The cargo shall be discharged only by deepwell pumps, hydraulically operated submerged pumps or inert gas displacement. Each cargo pump shall be arranged to ensure that the product does not heat significantly if the discharge line from the pump is shut off or otherwise blocked.
- 18.1.16** Tanks carrying these products shall be vented independently of tanks carrying other products. Facilities shall be provided for sampling the tank contents without opening the tank to atmosphere.
- 18.1.17** Cargo hoses used for transfer of these products shall be marked "FOR ALKYLENE OXIDE TRANSFER ONLY".
- 18.1.18** Hold spaces shall be monitored for these products. Hold spaces surrounding type A and type B independent tanks shall also be inerted and monitored for oxygen. The oxygen content of these spaces shall be maintained below 2% by volume. Portable sampling equipment is satisfactory.
- 18.1.19** Prior to disconnecting shore lines, the pressure in liquid and vapour lines shall be relieved through suitable valves installed at the loading header. Liquid and vapour from these lines shall not be discharged to atmosphere.
- 18.1.20** Tanks shall be designed for the maximum pressure expected to be encountered during loading, carriage or unloading of cargo.
- 18.1.21** Tanks for the carriage of propylene oxide with a design vapour pressure of less than 0.06 MPa, and tanks for the carriage of ethylene oxide-propylene oxide mixtures with a design vapour pressure of less than 0.12 MPa, shall have a cooling system to maintain the cargo below the reference temperature. The reference temperatures are referred to in Ch 9, Sec 15, [1.1.3].
- 18.1.22** Pressure relief valve settings shall not be less than 0,02 MPa gauge; and for type C independent tanks not greater than 0,7 MPa gauge for the carriage of propylene oxide and not greater than 0,53 MPa gauge for the carriage of ethylene oxide-propylene oxide mixtures.
- 18.1.23** The piping system for tanks to be loaded with these products shall be completely separate from piping systems for all other tanks, including empty tanks, and from all cargo compressors. If the piping system for the tanks to be loaded with these products is not independent, as defined in Ch 9, Sec 1, [4.1.28], the required piping separation shall be accomplished by the removal of spool pieces, valves, or other pipe sections and the installation of blank flanges at these locations. The required separation applies to all liquid and vapour piping, liquid and vapour vent lines and any other possible connections such as common inert gas supply lines.
- 18.1.24** The products shall be transported only in accordance with cargo handling plans approved by the Society. Each intended loading arrangement shall be shown on a separate cargo handling plan. Cargo handling plans shall show the entire cargo piping system and the locations for installation of the blank flanges needed to meet the above piping separation requirements. A copy of each approved cargo handling plan shall be kept on board the ship. The International Certificate of Fitness for the Carriage of Liquefied Gases in Bulk shall be endorsed to include references to the approved cargo handling plans.
- 18.1.25** Before each initial loading of these products, and before every subsequent return to such service, certification verifying that the required piping separation has been achieved shall be obtained from a responsible person acceptable to the port Administration and carried on board the ship. Each connection between a blank flange and pipeline flange shall be fitted with a wire and seal by the responsible person to ensure that inadvertent removal of the blank flange is impossible.
- 18.1.26** The maximum allowable loading limits for each tank shall be indicated for each loading temperature that may be applied, in accordance with Ch 9, Sec 15, [1.5].
- 18.1.27** The cargo shall be carried under a suitable protective padding of nitrogen gas. An automatic nitrogen make-up system shall be installed to prevent the tank pressure falling below 0,007 MPa gauge in the event of product temperature fall due to ambient conditions or malfunctioning of refrigeration system. Sufficient nitrogen shall be available on board to satisfy the demand of the automatic pressure control. Nitrogen of commercially pure quality (99.9% by volume) shall be used for padding. A battery of nitrogen bottles, connected to the cargo tanks through a pressure reduction valve, satisfies the intention of the expression "automatic" in this context.

18.1.28 The cargo tank vapour space shall be tested prior to and after loading to ensure that the oxygen content is 2% by volume or less.

18.1.29 A water-spray system of sufficient capacity shall be provided to blanket effectively the area surrounding the loading manifold, the exposed deck piping associated with product handling and the tank domes. The arrangement of piping and nozzles shall be such as to give a uniform distribution rate of 10 litre/m²/min. The arrangement shall ensure that any spilled cargo is washed away.

18.1.30 The water-spray system shall be capable of local and remote manual operation in case of a fire involving the cargo containment system. Remote manual operation shall be arranged such that the remote starting of pumps supplying the water-spray system and remote operation of any normally closed valves in the system can be carried out from a suitable location outside the cargo area, adjacent to the accommodation spaces and readily accessible and operable in the event of fire in the areas protected.

18.1.31 When ambient temperatures permit, a pressurized water hose ready for immediate use shall be available during loading and unloading operations, in addition to the above water-spray requirements.

19 Vinyl chloride

19.1 General

19.1.1 In cases where polymerization of vinyl chloride is prevented by addition of an inhibitor, Article [8] is applicable. In cases where no inhibitor has been added, or the inhibitor concentration is insufficient, any inert gas used for the purposes of Article [6] shall contain no more oxygen than 0,1% by volume. Before loading is started, inert gas samples from the tanks and piping shall be analysed. When vinyl chloride is carried, a positive pressure shall always be maintained in the tanks and during ballast voyages between successive carriages.

20 Mixed C4 cargoes

20.1 General

20.1.1 Cargoes that may be carried individually under the requirements of this Code, notably butane, butylenes and butadiene, may be carried as mixtures subject to the provisions of this section. These cargoes may variously be referred to as "Crude C4", "Crude butadiene", "Crude steam-cracked C4", "Spent steam-cracked C4", "C4 stream", "C4 raffinate", or may be shipped under a different description. In all cases, the material safety data sheets (MSDS) shall be consulted as the butadiene content of the mixture is of prime concern as it is potentially toxic and reactive. While it is recognized that butadiene has a relatively low vapour pressure, if such mixtures contain butadiene they shall be regarded as toxic and the appropriate precautions applied.

20.1.2 If the mixed C4 cargo shipped under the terms of this section contains more than 50% (mole) of butadiene, the inhibitor precautions in [8] shall apply.

20.1.3 Unless specific data on liquid expansion coefficients is given for the specific mixture loaded, the filling limit restrictions of Ch 9, Sec 15 shall be calculated as if the cargo contained 100% concentration of the component with the highest expansion ratio.

21 Carbon dioxide: high purity

21.1 General

21.1.1 Interpretation and application for ships carrying liquefied carbon dioxide in bulk are given in Tab 2.

21.1.2 Uncontrolled pressure loss from the cargo can cause "sublimation" and the cargo will change from the liquid to the solid state. The precise "triple point" temperature of a particular carbon dioxide cargo shall be supplied before loading the cargo, and will depend on the purity of that cargo, and this shall be taken into account when cargo instrumentation is adjusted. The set pressure for the alarms and automatic actions described in this section shall be set to at least 0,05 MPa above the triple point for the specific cargo being carried. The "triple point" for pure carbon dioxide occurs at 0,5 MPa gauge and – 54.4°C.

21.1.3 There is a potential for the cargo to solidify in the event that a cargo tank relief valve, fitted in accordance with Ch 9, Sec 8, [2], fails in the open position. To avoid this, a means of isolating the cargo tank safety valves shall be provided and the requirements of Ch 9, Sec 8, [2.1.11], item b) do not apply when carrying this carbon dioxide. Discharge piping from safety relief valves shall be designed so they remain free from obstructions that could cause clogging. Protective screens shall not be fitted to the outlets of relief valve discharge piping, so the requirements of Ch 9, Sec 8, [2.1.18] do not apply.

21.1.4 Discharge piping from safety relief valves are not required to comply with Ch 9, Sec 8, [2.1.12], but shall be designed so they remain free from obstructions that could cause clogging. Protective screens shall not be fitted to the outlets of relief valve discharge piping, so the requirements of Ch 9, Sec 8, [2.1.18] do not apply.

21.1.5 Cargo tanks shall be continuously monitored for low pressure when a carbon dioxide cargo is carried. An audible and visual alarm shall be given at the cargo control position and on the bridge. If the cargo tank pressure continues to fall to within 0.05 MPa of the “triple point” for the particular cargo, the monitoring system shall automatically close all cargo manifold liquid and vapour valves and stop all cargo compressors and cargo pumps. The emergency shutdown system required by Ch 9, Sec 18, [3] may be used for this purpose.

21.1.6 All materials used in cargo tanks and cargo piping system shall be suitable for the lowest temperature that may occur in service, which is defined as the saturation temperature of the carbon dioxide cargo at the set pressure of the automatic safety system described in [21.1.2].

21.1.7 Cargo hold spaces, cargo compressor rooms and other enclosed spaces where carbon dioxide could accumulate shall be fitted with continuous monitoring for carbon dioxide build-up. This fixed gas detection system replaces the requirements of Ch 9, Sec 13, [6], and hold spaces shall be monitored permanently even if the ship has type C cargo containment.

22 Carbon dioxide: reclaimed quality

22.1 General

22.1.1 Specific relaxations may apply for ships carrying liquefied carbon dioxide (reclaimed quality) in bulk, as detailed in Tab 2.

22.1.2 The requirements of [21] also apply to this cargo. In addition, the materials of construction used in the cargo system shall also take account of the possibility of corrosion, in case the reclaimed quality carbon dioxide cargo contains impurities such as water, sulphur dioxide, etc., which can cause acidic corrosion or other problems.

Table 2 : Possible relaxations for ships carrying liquefied carbon dioxide in bulk

Reference	Relaxations
Ch 9, Sec 3, [1.1.3]	A single A-0 bulkhead is sufficient.
Ch 9, Sec 5, [7.4]	Electrical bonding of piping and tanks is not required.
Ch 9, Sec 10	Certified safe electrical equipment is not required.
Ch 9, Sec 11	This entire Section is not applicable.
Ch 9, Sec 12, [1.2.12]	Safe placing and safe construction of electrical fan motors is not required.
Ch 9, Sec 12, [1.2.15]	Protection screens in vent ducts are not required.
Ch 9, Sec 13, [6]	Only Ch 9, Sec 13, [6.1.13] and Ch 9, Sec 13, [6.1.14] are applicable.
Ch 9, Sec 18, [3.3]	Fusible elements in the emergency shutdown system are not required.

Section 18 Operating Requirements

1 General

1.1

1.1.1 This Section contains only the provisions of IGC Code article 18.10, as the other provisions of Chapter 18 of the IGC Code are operating requirements which are not within the scope of classification.

2 Cargo operating manual

2.1 General

2.1.1 *The ship shall be provided with copies of suitably detailed cargo system operation manuals approved by the Society such that trained personnel can safely operate the ship with due regard to the hazards and properties of the cargoes that are permitted to be carried.*

Note 1: As required in Ch 9, Sec 1, [5], the cargo operating manual is to be submitted for approval in order to check that all documents listed in [2.1.2] are included in the cargo operating manual.

2.1.2 *The content of the manuals shall include, but not be limited to:*

- *overall operation of the ship from dry-dock to dry-dock, including procedures for cargo tank cooldown and warm-up, transfer (including ship-to-ship transfer), cargo sampling, gas-freeing, ballasting, tank cleaning and changing cargoes;*
- *cargo temperature and pressure control systems;*
- *cargo system limitations, including minimum temperatures (cargo system and inner hull), maximum pressures, transfer rates, filling limits and sloshing limitations;*
- *nitrogen and inert gas systems;*
- *firefighting procedures: operation and maintenance of firefighting systems and use of extinguishing agents;*
- *special equipment needed for the safe handling of the particular cargo;*
- *fixed and portable gas detection;*
- *control, alarm and safety systems;*
- *emergency shutdown systems;*
- *procedures to change cargo tank pressure relief valve set pressures in accordance with Ch 9, Sec 8, [2.1.10] and Ch 9, Sec 4, [3.3.2]; and*
- *emergency procedures, including cargo tank relief valve isolation, single tank gas-freeing and entry and emergency ship-to-ship transfer operations.*

3 Cargo emergency shutdown (ESD) system

3.1 General

3.1.1 *A cargo emergency shutdown system shall be fitted to stop cargo flow in the event of an emergency, either internally within the ship, or during cargo transfer to ship or shore. The design of the ESD system shall avoid the potential generation of surge pressures within cargo transfer pipe work (see [3.2.1]).*

3.1.2 *Auxiliary systems for conditioning the cargo that use toxic or flammable liquids or vapours shall be treated as cargo systems for the purposes of ESD. Indirect refrigeration systems using an inert medium, such as nitrogen, need not be included in the ESD function.*

3.1.3 *The ESD system shall be activated by the manual and automatic initiations listed in Tab 1. Any additional initiations shall only be included in the ESD system if it can be shown that their inclusion does not reduce the integrity and reliability of the system overall.*

3.1.4 *Ship's ESD systems shall incorporate a ship-shore link in accordance with recognized standards.*

Note 1: ISO 28460:2010 Petroleum and natural gas industries - Installation and equipment for liquefied natural gas - Ship-to-shore interface and port operations.

3.1.5 *A functional flow chart of the ESD system and related systems shall be provided in the cargo control station and on the navigation bridge.*

Table 1 : ESD functional arrangements

Initiation	Shutdown action							
	Pumps		Compressor systems				Valves	Link
	Cargopumps and cargo booster pumps	Spray/ stripping pumps	Vapour return compressors	Fuel gas compressors	Reliquefaction plant (3), including condensate return pumps, if fitted	Gas combustion unit	ESD valves	Signal to ship/shore link (4)
Emergency push buttons (see [3.3.1])	F	F	F	see (6)	F	F	F	F
Fire detection on deck or in compressor house (1) (see [3.3.2])	F	F	F	F	F	F	F	F
High level in cargo tank (12)	F	F	F	see (5) see (6)	see (5) see (7)	see (5)	see (10)	F
Signal from ship/shore link (see [3.1.4])	F	F	F	see (6)	see (7)	NA	F	NA
Loss of motive power to ESD valves (2)	F	F	F	see (6)	see (7)	NA	F	F
Main electric power failure ("blackout")	see (11)	see (11)	see (11)	see (11)	see (11)	see (11)	F	F
Level alarm override (13)	see (8)	see (8) see (9)	F	see (5)	see (5)	see (5)	F	F

(1) Fusible plugs, electronic point temperature monitoring or area fire detection may be used for this purpose on deck.
(2) Failure of hydraulic, electric or pneumatic power for remotely operated ESD valve actuators.
(3) Indirect refrigeration systems which form part of the reliquefaction plant do not need to be included in the ESD function if they employ an inert medium such as nitrogen in the refrigeration cycle.
(4) Signal need not indicate the event initiating ESD.
(5) These items of equipment can be omitted from these specific automatic shutdown initiators, provided the equipment inlets are protected against cargo liquid ingress.
(6) If the fuel gas compressor is used to return cargo vapour to shore, it shall be included in the ESD system when operating in this mode.
(7) If the reliquefaction plant compressors are used for vapour return/shore line clearing, they shall be included in the ESD system when operating in that mode.
(8) The override system permitted by Ch 9, Sec 13, [3.1.8] may be used at sea to prevent false alarms or shutdowns. When level alarms are overridden, operation of cargo pumps and the opening of manifold ESD valves shall be inhibited except when high-level alarm testing is carried out in accordance with Ch 9, Sec 13, [3.1.6] (see [3.3.4]).
(9) Cargo spray or stripping pumps used to supply forcing vaporizer may be excluded from the ESD system only when operating in that mode.
(10) The sensors referred to in Ch 9, Sec 13, [3.1.3] may be used to close automatically the tank filling valve for the individual tank where the sensors are installed, as an alternative to closing the ESD valve as referred to in [3.2.2]. If this option is adopted, activation of the full ESD system shall be initiated when the high-level sensors in all the tanks to be loaded have been activated.
(11) These items of equipment shall be designed not to restart upon recovery of main electric power and without confirmation of safe conditions.
(12) see Ch 9, Sec 13, [3.1.3] and Ch 9, Sec 13, [3.1.4]
(13) see Ch 9, Sec 13, [3.1.8]
Note 1: F = Functional requirement; NA = Not applicable.
Note 2: In applying the second sentence of (8), a hardware system such as an electric or mechanical interlocking device is to be provided to prevent inadvertent operation of cargo pumps and inadvertent opening of manifold ESD valves.

3.2 ESD valve requirements

3.2.1 General

- a) The term ESD valve means any valve operated by the ESD system.
- b) ESD valves shall be remotely operated, be of the fail-closed type (closed on loss of actuating power), be capable of local manual closure and have positive indication of the actual valve position. As an alternative to the local manual closing of the ESD valve, a manually operated shut-off valve in series with the ESD valve shall be permitted. The manual valve shall be located adjacent to the ESD valve. Provisions shall be made to handle trapped liquid should the ESD valve close while the manual valve is also closed.

The cargo stations in way of which the fusible elements are to be fitted are to be intended as the loading and unloading manifolds.

- c) ESD valves in liquid piping systems shall close fully and smoothly within 30 s of actuation. Information about the closure time of the valves and their operating characteristics shall be available on board, and the closing time shall be verifiable and repeatable.
- d) The closing time of the valve, in second, referred to in Ch 9, Sec 13, [3.1.1] to Ch 9, Sec 13, [3.1.4] (i.e. time from shutdown signal initiation to complete valve closure) shall not be greater than $3600 U / LR$, where

U : Ullage volume at operating signal level, in m^3

LR : Maximum loading rate agreed between ship and shore facility, in m^3/h .

The loading rate shall be adjusted to limit surge pressure on valve closure to an acceptable level, taking into account the loading hose or arm, the ship and the shore piping systems, where relevant.

3.2.2 Ship-shore and ship-ship manifold connections

One ESD valve shall be provided at each manifold connection. Cargo manifold connections not being used for transfer operations shall be blanked with blank flanges rated for the design pressure of the pipeline system.

3.2.3 Cargo system valves

If cargo system valves as defined in Ch 9, Sec 5, [5] are also ESD valves within the meaning of [3], then the requirements of [3] shall apply.

3.3 ESD system controls

3.3.1 As a minimum, the ESD system shall be capable of manual operation by a single control on the bridge and either in the control position required by Ch 9, Sec 13, [1.1.4] or the cargo control room, if installed, and no less than two locations in the cargo area.

3.3.2 The ESD system shall be automatically activated on detection of a fire on the weather decks of the cargo area and/or cargo machinery spaces. As a minimum, the method of detection used on the weather decks shall cover the liquid and vapour domes of the cargo tanks, the cargo manifolds and areas where liquid piping is dismantled regularly. Detection may be by means of fusible elements designed to melt at temperatures between 98°C and 104°C, or by area fire detection methods.

3.3.3 Cargo machinery that is running shall be stopped by activation of the ESD system in accordance with the cause and effect matrix in Tab 1.

3.3.4 The ESD control system shall be configured so as to enable the high-level testing required in Ch 9, Sec 13, [3.1.6] to be carried out in a safe and controlled manner. For the purpose of the testing, cargo pumps may be operated while the overflow control system is overridden. Procedures for level alarm testing and re-setting of the ESD system after completion of the high-level alarm testing shall be included in the operation manual.

3.4 Additional shutdowns

3.4.1 The requirements of Ch 9, Sec 8, [3.1.1], item a), to protect the cargo tank from external differential pressure may be fulfilled by using an independent low pressure trip to activate the ESD system, or, as minimum, to stop any cargo pumps or compressors.

3.4.2 An input to the ESD system from the overflow control system required by Ch 9, Sec 13, [3] may be provided to stop any cargo pumps or compressors' running at the time a high level is detected, as this alarm may be due to inadvertent internal transfer of cargo from tank to tank.

3.5 Pre-operations testing

3.5.1 Cargo emergency shutdown and alarm systems involved in cargo transfer shall be checked and tested before cargo handling operations begin.

3.6 Testing

3.6.1 Ship operators should periodically verify that the ESD valves onboard their vessels function correctly. The test results are to be recorded.

Also, as part of the check on the integrity of the cargo containment system, the ESD valves are to be pressure tested and internally inspected. Pressure testing at the same pressure as working pressure is recommended to be conducted every 5 years.

Note 1: The instruction manual produced by the ESD valve manufacturer providing information on installing, servicing and reassembly of the valves should be retained onboard the ship.

Section 19 Summary of Minimum Requirements

1 General

1.1 Explanatory notes to the summary of minimum requirements

1.1.1 Product name

The product name shall be used in the shipping document for any cargo offered for bulk shipments. Any additional name may be included in brackets after the product name. In some cases, the product names are not identical with the names given in previous issues of the Code.

1.1.2 Ship type

- Ship type 1G (see Ch 9, Sec 2, [1.1.2], item a))
- Ship type 2G (see Ch 9, Sec 2, [1.1.2], item b))
- Ship type 2PG (see Ch 9, Sec 2, [1.1.2], item c))
- Ship type 3G (see Ch 9, Sec 2, [1.1.2], item d)).

1.1.3 Independent tank type C required

Type C independent tank (see Ch 9, Sec 4, [10]).

1.1.4 Tank environmental control

- Inert : Inerting (see Ch 9, Sec 9, [1.4])
 Dry : Drying (see Ch 9, Sec 17, [7])
 – : No special requirements under the Code.

1.1.5 Vapour detection

- F : Flammable vapour detection
 T : Toxic vapour detection
 F + T : Flammable and toxic vapour detection
 A : Asphyxiant.

1.1.6 Gauging

- I : Indirect or closed (see Ch 9, Sec 13, [2.1.4], item a) and Ch 9, Sec 13, [2.1.4], item b))
 R : Indirect, closed or restricted (from Ch 9, Sec 13, [2.1.4], item a) to Ch 9, Sec 13, [2.1.4], item d))
 C : Indirect or closed (from Ch 9, Sec 13, [2.1.4], item a) to Ch 9, Sec 13, [2.1.4], item c)).

1.1.7 Special requirements

When specific reference is made to Ch 9, Sec 14 and/or to Ch 9, Sec 17, these requirements shall be additional to the requirements in any other column.

1.1.8 Refrigerant gases

Non-toxic and non-flammable gases.

1.1.9

Unless otherwise specified, gas mixtures containing less than 5% total acetylenes may be transported with no further requirements than those provided for the major components.

2 Additional information on products

2.1

2.1.1 Tab 2 lists some additional information for those products which are listed in Tab 1.

The list shown in Tab 2 gives properties for pure products. The specific gravity to be taken into account for the design of a ship might be altered considering the actual properties of the commercial product.

Information on temperature classes and explosion groups for electrical equipment in connection with the products to be carried is indicated in Ch 9, Sec 10, Tab 1.

Table 1 : Summary of minimum requirements

Product name	Ship type	Independent tank type C required	Control of vapour space within cargo tanks	Vapour detection	Gauging	Special requirements
Acetaldehyde	2G/2PG	-	Inert	F + T	C	Ch 9, Sec 14, [1.4.3], Ch 9, Sec 14, [1.3.3], item a), Ch 9, Sec 17, [4.1.1], Ch 9, Sec 17, [6.1.1], item a)
Ammonia, anhydrous	2G/2PG	-	-	T	C	Ch 9, Sec 14, [1.4], Ch 9, Sec 17, [2.1.1], item a), Ch 9, Sec 17, [12]
Butadiene (all isomers)	2G/2PG	-	-	F + T	C	Ch 9, Sec 14, [1.4], Ch 9, Sec 17, [2.1.1], item b), Ch 9, Sec 17, [4.1.2], Ch 9, Sec 17, [4.1.3], Ch 9, Sec 17, [6], Ch 9, Sec 17, [8]
Butane (all isomers)	2G/2PG	-	-	F	R	
Butane-propane mixture	2G/2PG	-	-	F	R	
Butylenes (all isomers)	2G/2PG	-	-	F	R	
Carbon Dioxide (high purity)	3G	-	-	A	R	Ch 9, Sec 17, [21]
Carbon Dioxide (Reclaimed quality)	3G	-	-	A	R	Ch 9, Sec 17, [22]
Chlorine	1G	Yes	Dry	T	I	Ch 9, Sec 14, [1.4], Ch 9, Sec 17, [3.1.2], Ch 9, Sec 17, [4.1.1], Ch 9, Sec 17, [5], Ch 9, Sec 17, [7], Ch 9, Sec 17, [9], Ch 9, Sec 17, [13]
Diethyl ether (1)	2G/2PG	-	Inert	F + T	C	Ch 9, Sec 14, [1.4.2], Ch 9, Sec 14, [1.4.3], Ch 9, Sec 17, [2.1.1], item f), Ch 9, Sec 17, [3.1.1], Ch 9, Sec 17, [6.1.1], item a), Ch 9, Sec 17, [9], Ch 9, Sec 17, [10], Ch 9, Sec 17, [11.1.2], Ch 9, Sec 17, [11.1.3]
Dimethylamine	2G/2PG	-	-	F + T	C	Ch 9, Sec 14, [1.4], Ch 9, Sec 17, [2.1.1], item a)
Dimethyl Ether	2G/2PG	-	-	F + T	C	
Ethane		-	-	F	R	
Ethyl Chloride	2G/2PG	-	-	F + T	C	
Ethylene	2G	-	-	F	R	
Ethylene oxide	1G	Yes	Inert	F + T	C	Ch 9, Sec 14, [1.4], Ch 9, Sec 17, [2.1.1], item b), Ch 9, Sec 17, [3.1.2], Ch 9, Sec 17, [4.1.1], Ch 9, Sec 17, [6.1.1], item a), Ch 9, Sec 17, [6.1.1], item a), Ch 9, Sec 17, [14]
Ethylene oxide-propylene oxide mixtures with ethylene oxide content of not more than 30% by weight (1)	2G/2PG	-	Inert	F + T	C	Ch 9, Sec 14, [1.4.3], Ch 9, Sec 17, [3.1.1], Ch 9, Sec 17, [4.1.1], Ch 9, Sec 17, [6.1.1], item a), Ch 9, Sec 17, [9], Ch 9, Sec 17, [10], Ch 9, Sec 17, [18]
Isoprene (1) (all isomers)	2G/2PG	-	-	F	R	Ch 9, Sec 14, [1.4.3], Ch 9, Sec 17, [8], Ch 9, Sec 17, [9], Ch 9, Sec 17, [11.1.1]
Isoprene (part refined) (1)	2G/2PG	-	-	F	R	Ch 9, Sec 14, [1.4.3], Ch 9, Sec 17, [8], Ch 9, Sec 17, [9], Ch 9, Sec 17, [11.1.1]
Isopropylamine (1)	2G/2PG	-	-	F + T	C	Ch 9, Sec 14, [1.4.2], Ch 9, Sec 14, [1.4.3], Ch 9, Sec 17, [2.1.1], item d), Ch 9, Sec 17, [9], Ch 9, Sec 17, [10], Ch 9, Sec 17, [11.1.1], Ch 9, Sec 17, [15]
Methane (LNG)	2G	-	-	F	C	

(1) This cargo is also covered by the IBC Code.

Product name	Ship type	Independent tank type C required	Control of vapour space within cargo tanks	Vapour detection	Gauging	Special requirements
Methyl acetylene-propadiene mixtures	2G/2PG	-	-	F	R	Ch 9, Sec 17, [16]
Methyl bromide	1G	Yes	-	F + T	C	Ch 9, Sec 14, [1.4], Ch 9, Sec 17, [2.1.1], item c), Ch 9, Sec 17, [3.1.2], Ch 9, Sec 17, [4.1.1], Ch 9, Sec 17, [5]
Methyl chloride	2G/2PG	-	-	F + T	C	Ch 9, Sec 17, [2.1.1], item c)
Mixed C4 Cargoes	2G/2PG	-	-	F + T	C	Ch 9, Sec 14, [1.4], Ch 9, Sec 17, [2.1.1], item b), Ch 9, Sec 17, [4.1.2], Ch 9, Sec 17, [4.1.3], Ch 9, Sec 17, [6], Ch 9, Sec 17, [20]
Monoethylamine (1)	2G/2PG	-	-	F + T	C	Ch 9, Sec 14, [1.4], Ch 9, Sec 17, [2.1.1], item a), Ch 9, Sec 17, [3.1.1], Ch 9, Sec 17, [9], Ch 9, Sec 17, [10], Ch 9, Sec 17, [11.1.1], Ch 9, Sec 17, [15]
Nitrogen	3G	-	-	A	C	Ch 9, Sec 17, [17]
Pentane (all isomers) (1)	2G/2PG	-	-	F	R	Ch 9, Sec 17, [9], Ch 9, Sec 17, [11]
Pentene (all isomers) (1)	2G/2PG	-	-	F	R	Ch 9, Sec 17, [9], Ch 9, Sec 17, [11]
Propane	2G/2PG	-	-	F	R	
Propylene	2G/2PG	-	-	F	R	
Propylene oxide (1)	2G/2PG	-	Inert	F + T	C	Ch 9, Sec 14, [1.4.3], Ch 9, Sec 17, [3.1.1], Ch 9, Sec 17, [4.1.1], Ch 9, Sec 17, [6.1.1], item a), Ch 9, Sec 17, [9], Ch 9, Sec 17, [10], Ch 9, Sec 17, [18]
Refrigerant gases	3G	-	-	-	R	
Sulphur dioxide	1G	Yes	Dry	T	C	Ch 9, Sec 14, [1.4], Ch 9, Sec 17, [3.1.2], Ch 9, Sec 17, [4.1.1], Ch 9, Sec 17, [5], Ch 9, Sec 17, [17]
Vinyl chloride	2G/2PG	-	-	F + T	C	Ch 9, Sec 14, [1.4.2], Ch 9, Sec 14, [1.4.3], Ch 9, Sec 17, [2.1.1], item b), Ch 9, Sec 17, [2.1.1], item c), Ch 9, Sec 17, [3.1.1], Ch 9, Sec 17, [6], Ch 9, Sec 17, [19]
Vinyl ethyl ether (1)	2G/2PG	-	Inert	F + T	C	Ch 9, Sec 14, [1.4.2], Ch 9, Sec 14, [1.4.3], Ch 9, Sec 17, [2.1.1], item b), Ch 9, Sec 17, [3.1.1], Ch 9, Sec 17, [6.1.1], item a), Ch 9, Sec 17, [8], Ch 9, Sec 17, [9], Ch 9, Sec 17, [10], Ch 9, Sec 17, [11.1.2], Ch 9, Sec 17, [11.1.3]
Vinylidene chloride (1)	2G/2PG	-	Inert	F + T	C	Ch 9, Sec 14, [1.4.2], Ch 9, Sec 14, [1.4.3], Ch 9, Sec 17, [2.1.1], item e), Ch 9, Sec 17, [6.1.1], item a), Ch 9, Sec 17, [8], Ch 9, Sec 17, [9], Ch 9, Sec 17, [10]

(1) This cargo is also covered by the IBC Code.

Table 2 : Additional information on products

Product name	Boiling temperature (°C)	Specific gravity at boiling point (kg/m ³)	Ratio vapour/air density
Acetaldehyde	21	780	1,52
Ammonia, anhydrous	-33	682	0,60
Butiadene	-5	650	1,88
N-Butane / ISO-butane	-0,5 / -12	601	2,00
Butylenes	-6,3 / -7	625	1,94
Carbon dioxide	-79,0	1180	1,50
Chlorine	-34,5	1562	2,49
Diethyl ether	34	640	2,55
Dimethylamine	7	671	1,55
Dimethyl ether	-24,4	735	1,62
Ethane	-89	544	1,05
Ethyl chloride	12	920	2,20
Ethylene	-104	568	0,97
Ethylene oxide	11	870	1,52
Isoprene	34	680	2,40
Isopropylamine	32	700	2,03
Methane (LNG)	-161	422	0,55
Methyl acetylene/propadiene mixture	-38 / -20	-	1,48
Methyl bromide	4	1721	3,30
Methyl chloride	-24	1004	1,79
Mixed C4	-	-	-
Monoethylamine	16,6	690	1,56
Nitrogen	-196	806	0,97
Pentanes (all isomers)	27 / 36	610	2,50
Pentene (all isomers)	30 / 36	610	2,40
Propane	-42	581	1,55
Propylene	-47	610	1,48
Propylene oxides	34	860	2,00
Refrigerant gases			
Dichlorodifluoromethane (R12)	-30	1487	4,26
Dichloromonofluoroethane (R21)	8,86	1405	3,90
Dichlorotetrafluoroethane (R114)	3,59	1518	6.1
Monochlorodifluoromethane (R22)	-41	1409	3.21
Monochlorotetrafluoroethane (R124)	-	-	4,70
Monochlorotrifluoromethane (R13)	-81,48	1521	3,60
Sulphur dioxide	-10	1461	2,30
Vinyl chloride	-14	970	2,15
Vinyl ethyl ether	36	754	2,50
Vinylidene chloride	32	1250	3,45

Section 20 Hull Scantling

1 General

1.1 Application

1.1.1 The requirements in this Section apply to the hull structure, with the exception of the independent tank structure and tank supports, which are to be in compliance with Ch 9, Sec 4.

1.1.2 The requirements in this Section apply in addition to the requirements given in NR686 for ships equipped with membrane tanks.

2 Flooding for ships with independent tanks

2.1 General

2.1.1 The net scantling of structural elements subject to flooding pressure is to be checked using the formula given in Pt B, Ch 7, Sec 4, Pt B, Ch 7, Sec 5 and Pt B, Ch 7, Sec 6, considering a still water bending moment of $0,5 M_{sw-max}$ and a draught corresponding to the deepest equilibrium waterline in damage condition for transverse bulkhead.

At early stage of design, when damage stability calculations are not available, calculation with draft corresponding to $0,8 D$ without heel may be considered.

3 Finite element model

3.1 General

3.1.1 For the checking of the scantlings of primary supporting members, a three-dimensional finite element model is required. The check is to be made in accordance with Part B, Chapter 8, taking into account the structural modeling principles given in [3.2].

3.2 Structural modeling

3.2.1 Modeling principles

The following primary supporting members are to be modeled:

- outer shell, inner bottom, main deck, trunk deck, longitudinal and transverse bulkhead plating
- double-bottom longitudinal girders
- double-side horizontal stringers
- deck longitudinal girders
- transverse web frames with main frames if relevant
- primary supporting members of transverse bulkheads.

3.2.2 Model extension for units with independent tanks

For units with independent tanks, the structural model is to include the primary supporting members of the hull (see a)) and the tanks with their supporting members and key systems.

The cargo tank model is to include the following primary members:

- shell plating
- bulkhead plating, including wash bulkheads if any
- bottom plating
- top plating
- transverse web frames
- horizontal stringers
- girders.

3.2.3 Modeling of supports and keys

The cargo tanks are linked to the hold by the following supports and keys, acting in one direction:

- vertical supports (Z direction)
- antipitching keys (X direction), used also as anticollision keys
- antirolling keys (Y direction)
- antiflotation keys (Z direction).

They can be modeled by either linear elements (bar, flexible mounts, springs), or non-linear elements (gap elements).

When linear elements are used to model keys and supports not allowing tension loads, they are to be deleted when in tension. Stiffness of these linear and/or non-linear elements is to be representative of the actual stiffness of the supports and keys.

3.2.4 Stiffness of supports and keys for independent tanks

The axial stiffness of elements used for the modeling of supports and keys of independent tanks is to be calculated taking into account the stiffness of:

- the support in way of tank
- the spacer
- the support in way of hull.

The stiffness of the pad located between the lower and upper parts of the support may be calculated as follows:

$$K = E S / h$$

where:

- K : Stiffness of the pad, in N/mm
- E : Young modulus of the pad, in N/mm²
- S : Sectional area of the pad, in mm²
- h : Height of the pad, in mm.

The stiffness of the gap or spring element is to be taken as: $K_{element} = K / N_{elements}$

with:

- $N_{elements}$: Number of elements used in the pad modeling.

3.2.5 Size of the elements

The mesh size should be equal to the spacing of the longitudinal ordinary stiffeners. Each of these longitudinal stiffeners is to be modeled. The aspect ratio of the elements should be as close to 1,0 as possible.

3.3 Load combinations for direct strength analysis

3.3.1 The loading conditions and associated draughts, SWBM and dynamic load cases to be applied on the finite element model are described in Tab 1.

Additional loading conditions defined in the loading manual may be considered when deemed necessary.

Table 1 : Loading conditions and associated draughts and SWBM for FEM model

Loading conditions	Type A and type C independent tanks		Membrane tanks		Dynamic load case
	Draught	SWBM	Draught	SWBM	
Homogeneous	T_{SC}	M_{SW-S}	T_{SC}	M_{SW-S}	All
Ballast	T_{BAL}	M_{SW-H}	T_{BAL}	M_{SW-H}	
Alternate: Full/Empty/Full	$0,9T_{SC}$	$0,7M_{SW-H}$	$0,9T_{SC}$	$0,9M_{SW-H}$	
Alternate: Empty/Full/Empty	$0,8T_{SC}$	$0,7M_{SW-S}$	$0,75T_{SC}$	$0,9M_{SW-S}$	
Note 1:					
M_{SW-S} : Design SWBM in sagging conditions					
M_{SW-H} : Design SWBM in hogging conditions.					

3.4 Yielding strength criteria

3.4.1 Yielding strength criteria for primary supporting members are defined in Pt B, Ch 7, Sec 6.

Yielding strength criteria for supporting members and keys systems are defined in Ch 9, Sec 4, [7.4] and Ch 9, Sec 4, [7.5].

3.5 Buckling check

3.5.1 Buckling strength criteria for primary supporting members are defined in Pt B, Ch 9, Sec 1.

4 Membrane tanks

4.1 General

4.1.1 The net scantlings of plating and ordinary stiffeners of membrane tanks are to be not less than those obtained from Part B, Chapter 7.

The hull girder loads and internal pressure to be considered are to be calculated according to Part B, Chapter 5, where the dynamic pressure is to be multiplied by 1,25.

4.1.2 The net scantlings of primary supporting members of membrane tanks are to be not less than those obtained from Part B, Chapter 7, where the hull girder loads and the internal pressure are to be calculated according to Part B, Chapter 5.

4.1.3 Moreover, the net scantlings of plating, ordinary stiffeners and primary supporting members of membrane tanks are to be not less than those obtained from Articles [2] to [3].

4.2 Sloshing loads

4.2.1 The net thicknesses of plating subject to sloshing pressure are to be checked using the formula given in Pt B, Ch 7, Sec 4, [4] with P_{sl} to be taken equal to P_{sl} given in NR686, App 1, [2.2].

No buckling check is required.

Areas to be checked for sloshing pressure are defined in NR686, App 1, [2.2].

4.2.2 The net section modulus of ordinary stiffeners subject to sloshing pressure, including longitudinals, are to be checked using the formulae given in Pt B, Ch 7, Sec 5, [1.3] with P_{sl} to be taken equal to P_{sl} given NR686, App 1, [2.2].

Areas to be checked for sloshing pressure are defined in NR686, App 1, [2.2].

No buckling check is required.

4.3 Collision loads

4.3.1 The structure of the tank is to be checked for collision loads using the pressure defined in NR686, Sec 1, [15.2] and criteria defined in Ch 9, Sec 4, [8.4.3].

5 Structural details

5.1 General

5.1.1 The specific requirements in Pt B, Ch 13, Sec 5, [2] for ships with the service notation **liquefied gas carrier** are to be complied with.

5.2 Local structural strength analysis

5.2.1 Screening criteria

For all details specific to liquefied gas carriers which are to be evaluated by screening according to Pt B, Ch 13, Sec 5, [2.4], the screening criteria as defined in Pt B, Ch 8, App 2, [1.2.3] is to be checked with:

- $\lambda_{sc} = \lambda_y$
- $\lambda_{scperm} = 0,95\lambda_{yperm}$

where:

- λ_y : Standard mesh yield utilisation factor, as defined in Pt B, Ch 8, App 1, [5.2.3]
- λ_{yperm} : Standard mesh permissible yield utilisation factor, as defined in Pt B, Ch 8, App 1, [5.2.3]

5.3 Connections of inner bottom with transverse cofferdam bulkheads

5.3.1 The thickness and material properties of the supporting floors are to be at least equal to those of the cofferdam bulkhead plating.

5.3.2 Vertical webs fitted within the cofferdam bulkhead are to be aligned with the double bottom girders.

5.3.3 Manholes in double bottom floors aligned with the cofferdam bulkhead plating are to be located as low as practicable and at mid-distance between two adjacent longitudinal girders.

Appendix 1 Guidance for Calculation of Pressures and Accelerations

1 Guidance to detailed calculation of internal pressure for static design purpose

1.1 Calculation of dynamic liquid pressure

1.1.1 This Appendix provides guidance for the calculation of the associated dynamic liquid pressure for the purpose of static design calculations. This pressure may be used for determining the internal pressure referred to in Ch 9, Sec 4, [3.3.2], item e), where:

- $(P_{gd})_{max}$, in MPa, is the associated liquid pressure determined using the maximum design accelerations.
- $(P_{gd}^{site})_{max}$, in MPa, is the associated liquid pressure determined using site specific accelerations.
- P_{eq} , in MPa, should be the greater of P_{eq1} and P_{eq2} calculated as follows:

$$P_{eq1} = P_o + (P_{gd})_{max}$$

$$P_{eq2} = P_h + (P_{gd}^{site})_{max}$$

1.1.2 The internal liquid pressures are those created by the resulting acceleration of the centre of gravity of the cargo due to the motions of the ship referred to in Ch 9, Sec 4, [3.4.2]. The value of internal liquid pressure P_{gd} , in MPa, resulting from combined effects of gravity and dynamic accelerations should be calculated as follows:

$$P_{gd} = a_{\beta} Z_{\beta} \frac{\rho}{1,02 \times 10^5}$$

where:

a_{β} : Dimensionless acceleration (i.e. relative to the acceleration of gravity), resulting from gravitational and dynamic loads, in an arbitrary direction β (see Fig 1).

For large tanks, an acceleration ellipsoid taking account of transverse vertical and longitudinal accelerations, should be used.

Methods for the calculation of acceleration in upright ship conditions and inclined ship conditions are given in [1.2]

Z_{β} : Largest liquid height (m) above the point where the pressure is to be determined measured from the tank shell in the β direction (see Fig 2).

The liquid heights Z_{β} are to be calculated in accordance with Fig 4 at each calculation point of the tank.

At each calculation point, the maximum internal pressure $(P_{gd})_{max}$ is to be obtained for the β direction which gives the maximum value of P_{gd} (see Fig 3).

Tank domes considered to be part of the accepted total tank volume shall be taken into account when determining Z_{β} , unless the total volume of tank domes V_d does not exceed the following value:

$$V_d = V_t \frac{100 - FL}{FL}$$

with:

V_t : Tank volume without any domes

FL : Filling limit according to Ch 9, Sec 15.

ρ : Maximum cargo density, in kg/m^3 , at the design temperature.

Where the maximum mass density of the liquid carried is not given, the following values are to be considered:

- $\rho_L = 0,50 \text{ t/m}^3 = 500 \text{ kg/m}^3$ for methane
- ρ_L according to Ch 9, Sec 19, Tab 2 for other products.

The direction that gives the maximum value $(P_{gd})_{max}$ or $(P_{gd}^{site})_{max}$ should be considered. The above formula applies only to full tanks.

Equivalent calculation procedures may be applied.

Figure 1 : Acceleration ellipsoid

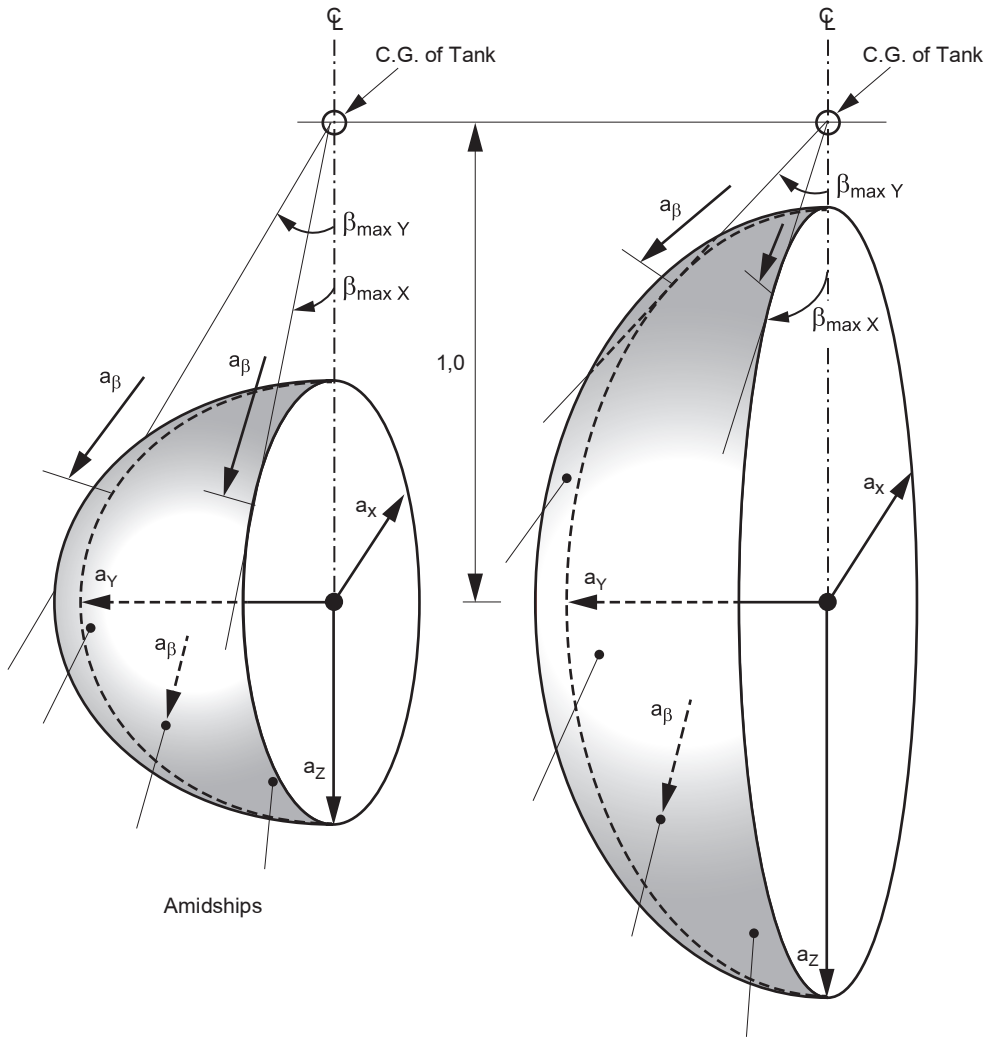

a_β resulting acceleration (static and dynamic) in arbitrary direction β
 a_x longitudinal component of acceleration
 a_y transverse component of acceleration
 a_z vertical component of acceleration

At 0,05L from FP

Figure 2 : Determination of internal pressure heads

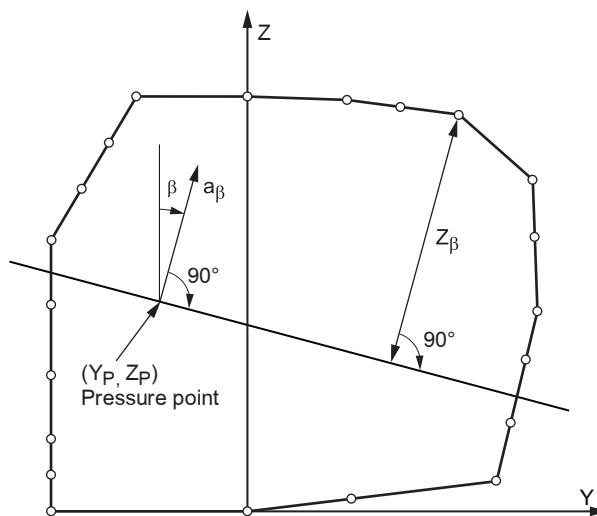

Figure 3 : Determination of internal pressure for pressure points 1, 2 and 3

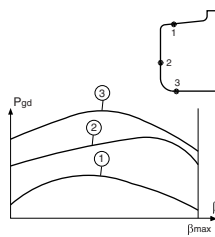
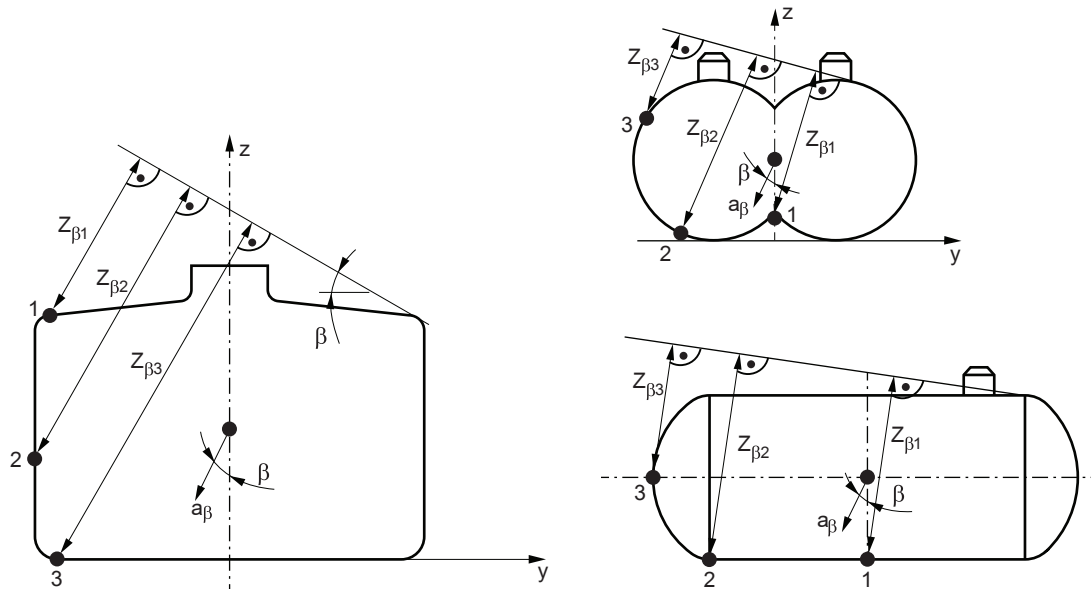

Figure 4 : Determination of liquid height Z_beta for pressure points 1, 2 and 3



1.2 Calculation of acceleration components

1.2.1 Guidance formulae for acceleration components

The following formulae are given as guidance for the components of acceleration due to ship's motions corresponding to a probability level of 10^{-8} in the North Atlantic and apply to ships with a length exceeding 50 m and at or near their service speed:

- vertical acceleration, as defined in Ch 9, Sec 4, [3.4.2]:

$$a_z = \pm a_0 \sqrt{1 + \left(5,3 - \frac{45}{L_0}\right)^2 \left(\frac{x}{L_0} + 0,05\right)^2 \left(\frac{0,6}{C_B}\right)^{1,5} + \left(\frac{0,6 y K^{1,5}}{B}\right)^2}$$

- transverse acceleration, as defined in Ch 9, Sec 4, [3.4.2]:

$$a_y = \pm a_0 \sqrt{0,6 + 2,5 \left(\frac{x}{L_0} + 0,05\right)^2 + K \left(1 + 0,6 K \frac{z}{B}\right)^2}$$

- longitudinal acceleration, as defined in Ch 9, Sec 4, [3.4.2]:

$$a_x = \pm a_0 \sqrt{0,06 + A^2 - 0,25 A}$$

where:

$$a_0 = 0,2 \frac{V}{\sqrt{L_0}} + \frac{34 - \frac{600}{L_0}}{L_0}$$

L_0 : Length of the ship for determination of scantlings as defined in recognized standards, in m

C_B : Block coefficient

B : Greatest moulded breadth of the ship, in m

x : Longitudinal distance, in m, from amidships to the centre of gravity of the tank with contents; x is positive forward of amidships, negative aft of amidships

y : Transverse distance, in m, from centreline to the centre of gravity of the tank with contents

z : Vertical distance, in m, from the ship's actual waterline to the centre of gravity of tank with contents; z is positive above and negative below the waterline

K : $K = 1$ in general.

For particular loading conditions and hull forms, determination of K according to the following formula may be necessary:

$$K = 13 GM / B$$

where:

$$K \geq 1$$

GM : metacentric height, in m

$$A = \left(0,7 - \frac{L_0}{1200} + 5 \frac{Z}{L_0} \right) \left(\frac{0,6}{C_B} \right)$$

V : Service speed, in knots

a_x, a_y, a_z : Maximum dimensionless accelerations (i.e. relative to the acceleration of gravity) in the respective directions. They are considered as acting separately for calculation purposes, and a_z does not include the component due to the static weight, a_y includes the component due to the static weight in the transverse direction due to rolling and a_x includes the component due to the static weight in the longitudinal direction due to pitching. The accelerations derived from the above formulae are applicable only to ships at or near their service speed, not while at anchor or otherwise near stationary in exposed locations.

1.2.2 Accelerations for type C tanks

The inertial internal liquid pressure is to be calculated considering the ship in the following mutually exclusive conditions:

a) Upright ship conditions

In these conditions, the ship encounters waves which produce ship motions in the X-Z plane, i.e. surge, heave and pitch.

The dimensionless acceleration a_β is to be obtained, for an arbitrary direction β , in accordance with Fig 5, in which the wave longitudinal and vertical accelerations a_x and a_z , respectively, are calculated from the formula in [1.2.1].

b) Inclined ship conditions

In these conditions, the ship encounters waves which produce ship motions in the X-Y and Y-Z planes, i.e. sway, heave, roll and yaw.

The dimensionless acceleration a_β is to be obtained, for an arbitrary direction β , in accordance with Fig 6, in which the wave transverse and vertical accelerations a_y and a_z , respectively, are calculated from the formula in [1.2.1].

Figure 5 : Dimensionless acceleration in upright ship condition

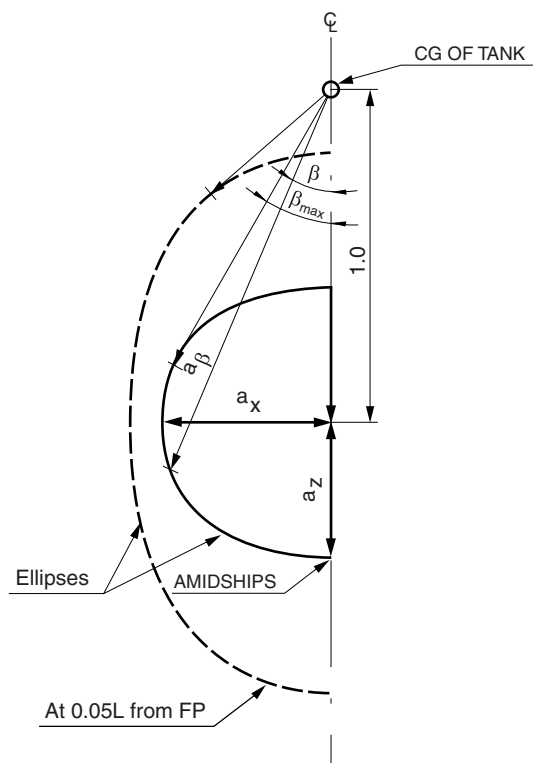
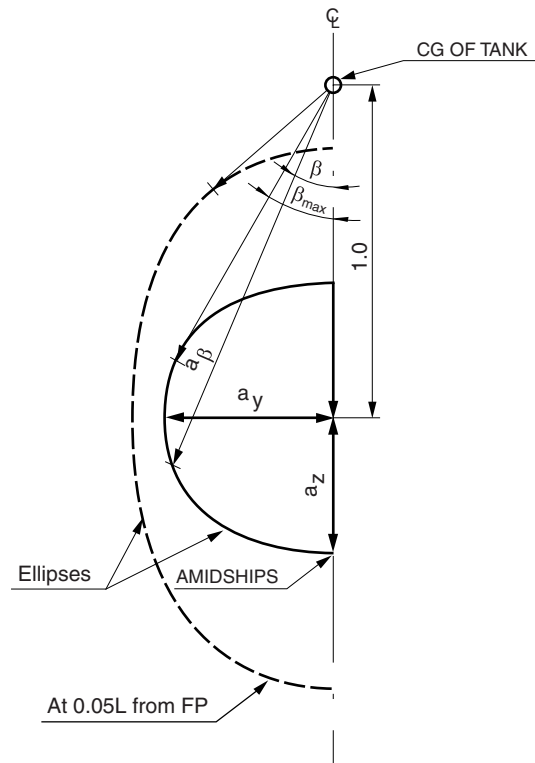

Figure 6 : Dimensionless acceleration in inclined ship condition



1.2.3 Accelerations for type A tanks

The inertial liquid pressure is to be calculated considering ship accelerations in the three directions.

The dimensionless acceleration a_β is to be obtained, for an arbitrary direction (β_x, β_y) , in accordance with Fig 1, in which the wave longitudinal, transverse and vertical accelerations a_x , a_y and a_z , respectively, are calculated from the formula in [1.2.1].

Note 1: For analysis based on three-dimensional models, several load cases are to be considered. For each load case, the pressures are to be calculated for each finite element of the tank boundary with a given direction (β_x, β_y) .

The choice and number of load cases considered is to be to the satisfaction of the Society with respect to maximising the inertial liquid pressure on each element of the tank boundary.

2 Internal pressure for integral tanks

2.1 General

2.1.1 The inertial internal liquid pressure is to be calculated according to Pt B, Ch 5, Sec 6.

3 Guidance to detailed calculation of pressure for a static heel angle of 30°C

3.1 Internal pressure calculation

3.1.1 Calculation of the highest point of each tank for 30° heel.

The components of accelerations to be used for this calculation are the following:

- Positive roll angle case:

$$a_y = g \sin \frac{\pi}{6}$$

$$a_z = (-g) \cos \frac{\pi}{6}$$

- Negative roll angle case:

$$a_y = (-g) \sin \frac{\pi}{6}$$

$$a_z = (-g) \cos \frac{\pi}{6}$$

3.1.2 Calculation of internal pressure

This highest point is then to be used as a reference for calculation of internal pressure as following:

$$P_{gd} = \rho g [a_y(y - y_H) + a_z(z - z_H)]$$

where y_H and z_H are the coordinates of the highest point.

3.2 Sea pressure calculation

3.2.1 The sea pressure is calculated as above:

- Positive roll angle:

$$P_s = \rho g \left[y \sin \frac{\pi}{6} + (T - z) \cos \frac{\pi}{6} \right]$$

- Negative roll angle:

$$P_s = \rho g \left[(-y) \sin \frac{\pi}{6} + (T - z) \cos \frac{\pi}{6} \right]$$

4 Calculation of dynamic pressure for collision loads

4.1 General

4.1.1 The dynamic pressure resulting from collision loads defined in Ch 9, Sec 4, [3.5.2] is the following:

$$P_w = \rho_I a_x |x - x_B|$$

where:

- for the case of a forward acceleration:

a_x : Longitudinal acceleration equal to: $a_x = 0,5g$

x_B : X co-ordinate, in m, of aft bulkhead of the tank.

- for the case of a aftward acceleration:

a_x : Longitudinal acceleration equal to: $a_x = 0,25g$

x_B : X co-ordinate, in m, of fore bulkhead of the tank.

Appendix 2 Correspondances between Part D, Chapter 9 and the IGC Code

1 General

1.1

1.1.1 Tab 1 to Tab 18 provide correspondances between the provisions of the IGC Code and those of the present Chapter.

Table 1 : Equivalences between Part D, Chapter 9 and Chapter 1 of the IGC Code

Ref. in IGC Code, Chapter 1	Ref. in Part D, Chapter 9	Ref. in IGC Code, Chapter 1	Ref. in Part D, Chapter 9	Ref. in IGC Code, Chapter 1	Ref. in Part D, Chapter 9
1.1.1	–	1.1.9	Ch 9, Sec 1, [2.1.9]	1.4.4.1	–
1.1.2.1	–	1.1.10	Ch 9, Sec 1, [2.1.10]	1.4.4.2	–
1.1.2.2	–	1.1.11	Ch 9, Sec 1, [2.1.11]	1.4.4.3	–
1.1.2.3	–	1.1.12	Ch 9, Sec 1, [2.1.12]	1.4.4.4	–
1.1.3	–	1.2	Ch 9, Sec 1, [4]	1.4.5.1	–
1.1.4.1	Ch 9, Sec 1, [2.1.1]	1.3.1	–	1.4.6.1	–
1.1.4.2	Ch 9, Sec 1, [2.1.2]	1.3.2	–	1.4.6.2.1	–
1.1.4.3	Ch 9, Sec 1, [2.1.3]	1.4.1.1	–	1.4.6.2.2	–
1.1.4.4	Ch 9, Sec 1, [2.1.4]	1.4.1.2	–	1.4.6.2.3	–
1.1.5	Ch 9, Sec 1, [2.1.5]	1.4.1.3	–	1.4.6.3	–
1.1.6.1	–	1.4.1.4	–	1.4.6.4	–
1.1.6.2	–	1.4.1.5	–	1.4.6.5	–
1.1.6.3	–	1.4.2	–	1.4.6.6	–
1.1.6.4	–	1.4.3.1	–	1.4.6.7	–
1.1.7.1	Ch 9, Sec 1, [2.1.6]	1.4.3.2	–	1.4.6.8	–
1.1.7.2	Ch 9, Sec 1, [2.1.7]	1.4.3.3	–	1.4.6.9	–
1.1.8	Ch 9, Sec 1, [2.1.8]				

Table 2 : Equivalences between Part D, Chapter 9 and Chapter 2 of the IGC Code

Ref. in IGC Code, Chapter 2	Ref. in Part D, Chapter 9	Ref. in IGC Code, Chapter 2	Ref. in Part D, Chapter 9	Ref. in IGC Code, Chapter 2	Ref. in Part D, Chapter 9
2.1.1	Ch 9, Sec 2, [1.1.1]	2.2.7	Ch 9, Sec 2, [2.1.10]	2.5.3	Ch 9, Sec 2, [5.1.3]
2.1.2	Ch 9, Sec 2, [1.1.2]	2.2.8	Ch 9, Sec 2, [2.1.11]	2.5.4	Ch 9, Sec 2, [5.1.4]
2.1.3	Ch 9, Sec 2, [1.1.3]	2.3	Ch 9, Sec 2, [3.1.1]	2.5.5	Ch 9, Sec 2, [5.1.5]
2.1.4	Ch 9, Sec 2, [1.1.4]	2.3.2.1	Ch 9, Sec 2, [3.2.1]	2.5.6	Ch 9, Sec 2, [5.1.6]
2.1.5	Ch 9, Sec 2, [1.1.5]	2.3.2.2	Ch 9, Sec 2, [3.2.2]	2.5.7	Ch 9, Sec 2, [5.1.7]
2.2.1	Ch 9, Sec 2, [2.1.1]	2.4.1	Ch 9, Sec 2, [4.1.1]	2.5.8	Ch 9, Sec 2, [5.1.9]
2.2.2	Ch 9, Sec 2, [2.1.2]	2.4.2	Ch 9, Sec 2, [4.1.3]	2.6.1	Ch 9, Sec 2, [6.1.2]
2.2.3	Ch 9, Sec 2, [2.1.4]	2.4.3	Ch 9, Sec 2, [4.1.4]	2.6.2	Ch 9, Sec 2, [6.1.3]
2.2.4	Ch 9, Sec 2, [2.1.6]	2.4.4	Ch 9, Sec 2, [4.1.5]	2.7	Ch 9, Sec 2, [7.1.1]
2.2.5	Ch 9, Sec 2, [2.1.7]	2.5.1	Ch 9, Sec 2, [5.1.1]	2.7.1	Ch 9, Sec 2, [7.1.3]
2.2.6	Ch 9, Sec 2, [2.1.9]	2.5.2	Ch 9, Sec 2, [5.1.2]	2.7.2	Ch 9, Sec 2, [7.1.4]

Table 3 : Equivalences between Part D, Chapter 9 and Chapter 3 of the IGC Code

Ref. in IGC Code, Chapter 3	Ref. in Part D, Chapter 9	Ref. in IGC Code, Chapter 3	Ref. in Part D, Chapter 9	Ref. in IGC Code, Chapter 3	Ref. in Part D, Chapter 9
3.1.1	Ch 9, Sec 3, [1.1.1]	3.3.4	Ch 9, Sec 3, [1.3.5]	3.6.4	Ch 9, Sec 3, [1.6.6]
3.1.2	Ch 9, Sec 3, [1.1.3]	3.3.5	Ch 9, Sec 3, [1.3.6]	3.6.5	Ch 9, Sec 3, [1.6.8]
3.1.3	Ch 9, Sec 3, [1.1.4]	3.3.6	Ch 9, Sec 3, [1.3.7]	3.6.6	Ch 9, Sec 3, [1.6.9]
3.1.4	Ch 9, Sec 3, [1.1.6]	3.3.7	Ch 9, Sec 3, [1.3.8]	3.6.7	Ch 9, Sec 3, [1.6.10]
3.1.5	Ch 9, Sec 3, [1.1.7]	3.4.1	Ch 9, Sec 3, [1.4.1]	3.7.1	Ch 9, Sec 3, [1.7.5]
3.1.6	Ch 9, Sec 3, [1.1.8]	3.4.2	Ch 9, Sec 3, [1.4.2]	3.7.2	Ch 9, Sec 3, [1.7.6]
3.1.7	Ch 9, Sec 3, [1.1.9]	3.4.3	Ch 9, Sec 3, [1.4.3]	3.7.3	Ch 9, Sec 3, [1.7.7]
3.2.1	Ch 9, Sec 3, [1.2.1]	3.5.1	Ch 9, Sec 3, [1.5.4]	3.7.4	Ch 9, Sec 3, [1.7.8]
3.2.2	Ch 9, Sec 3, [1.2.3]	3.5.2	Ch 9, Sec 3, [1.5.5]	3.7.5	Ch 9, Sec 3, [1.7.9]
3.2.3	Ch 9, Sec 3, [1.2.4]	3.5.3.1	Ch 9, Sec 3, [1.5.6], a)	3.8.1	Ch 9, Sec 3, [1.8.1]
3.2.4.1	Ch 9, Sec 3, [1.2.5]	3.5.3.2	Ch 9, Sec 3, [1.5.6], b)	3.8.2	Ch 9, Sec 3, [1.8.2]
3.2.4.2	Ch 9, Sec 3, [1.2.8]	3.5.3.3	Ch 9, Sec 3, [1.5.6], c)	3.8.3	Ch 9, Sec 3, [1.8.3]
3.2.4.3	Ch 9, Sec 3, [1.2.9]	3.5.3.4	Ch 9, Sec 3, [1.5.6], d)	3.8.4.1	Ch 9, Sec 3, [1.8.4], a)
3.2.4.4	Ch 9, Sec 3, [1.2.10]	3.5.3.5	Ch 9, Sec 3, [1.5.6], e)	3.8.4.2	Ch 9, Sec 3, [1.8.4], b)
3.2.5	Ch 9, Sec 3, [1.2.11]	3.5.4	Ch 9, Sec 3, [1.5.7]	3.8.4.3	Ch 9, Sec 3, [1.8.4], c)
3.2.6	Ch 9, Sec 3, [1.2.12]	3.5.5	Ch 9, Sec 3, [1.5.8]	3.8.4.4	Ch 9, Sec 3, [1.8.4], d)
3.2.7	Ch 9, Sec 3, [1.2.13]	3.5.6	Ch 9, Sec 3, [1.5.9]	3.8.5	Ch 9, Sec 3, [1.8.5]
3.3.1	Ch 9, Sec 3, [1.3.2]	3.6.1	Ch 9, Sec 3, [1.6.1]	3.8.6	Ch 9, Sec 3, [1.8.6]
3.3.2	Ch 9, Sec 3, [1.3.3]	3.6.2	Ch 9, Sec 3, [1.6.4]	3.8.7	Ch 9, Sec 3, [1.8.8]
3.3.3	Ch 9, Sec 3, [1.3.4]	3.6.3	Ch 9, Sec 3, [1.6.5]		

Table 4 : Equivalences between Part D, Chapter 9 and Chapter 4 of the IGC Code

Ref. in IGC Code, Chapter 4	Ref. in Part D, Chapter 9	Ref. in IGC Code, Chapter 4	Ref. in Part D, Chapter 9	Ref. in IGC Code, Chapter 4	Ref. in Part D, Chapter 9
4.1.1	Ch 9, Sec 4, [1.2.1]	4.18.1.6	Ch 9, Sec 4, [4.5.1], f)	4.22.6	Ch 9, Sec 4, [9.6.1]
4.1.2	Ch 9, Sec 4, [1.2.2]	4.18.2.1	Ch 9, Sec 4, [4.6.1]	4.22.7	Ch 9, Sec 4, [9.7.1]
4.1.3	Ch 9, Sec 4, [1.2.3]	4.18.2.2	Ch 9, Sec 4, [4.6.2]	4.23.1.1	Ch 9, Sec 4, [10.1.1]
4.1.4	Ch 9, Sec 4, [1.2.4]	4.18.2.3	Ch 9, Sec 4, [4.6.3]	4.23.1.2	Ch 9, Sec 4, [10.2.1]
4.1.5	NR686, Sec 1, [1.2.6]	4.18.2.4.1	Ch 9, Sec 4, [4.6.4], a)	4.23.1.3	Ch 9, Sec 4, [10.1.3]
4.1.6	Ch 9, Sec 4, [1.2.5]	4.18.2.4.2	Ch 9, Sec 4, [4.6.4], b)	4.23.2.1.1	Ch 9, Sec 4, [10.2.1], a)
4.1.7	Ch 9, Sec 4, [1.2.6]	4.18.2.5	Ch 9, Sec 4, [4.6.5]	4.23.2.1.2	Ch 9, Sec 4, [10.2.1], b)
4.1.8	Ch 9, Sec 4, [1.2.7]	4.18.2.6.1	Ch 9, Sec 4, [4.6.6], a)	4.23.2.1.3	Ch 9, Sec 4, [10.2.1], c)
4.2	Ch 9, Sec 4, [1.3.1]	4.18.2.6.2	Ch 9, Sec 4, [4.6.6], b)	4.23.2.2	Ch 9, Sec 4, [10.2.2]
4.3.1	Ch 9, Sec 4, [2.1.1]	4.18.2.6.3	Ch 9, Sec 4, [4.6.6], c)	4.23.2.3	Ch 9, Sec 4, [10.2.3]
4.3.2	Ch 9, Sec 4, [2.1.2]	4.18.2.6.4	Ch 9, Sec 4, [4.6.6], d)	4.23.2.4	Ch 9, Sec 4, [10.2.4]
4.3.3	Ch 9, Sec 4, [2.1.3]	4.18.2.7	Ch 9, Sec 4, [4.6.7]	4.23.2.5	Ch 9, Sec 4, [10.2.5]
4.3.4	Ch 9, Sec 4, [2.1.4]	4.18.2.8	Ch 9, Sec 4, [4.6.8]	4.23.3.1	Ch 9, Sec 4, [10.3.2]
4.3.5	Ch 9, Sec 4, [2.1.5]	4.18.2.9	Ch 9, Sec 4, [4.6.9]	4.23.3.2	Ch 9, Sec 4, [10.3.3]
4.3.6	Ch 9, Sec 4, [2.1.6]	4.18.3.1	Ch 9, Sec 4, [4.7.1]	4.23.4	Ch 9, Sec 4, [10.4.1]
4.4.1	Ch 9, Sec 4, [2.2.1]	4.18.3.2	Ch 9, Sec 4, [4.7.2]	4.23.5.1	Ch 9, Sec 4, [10.5.1]
4.4.2	Ch 9, Sec 4, [2.2.2]	4.18.3.3	Ch 9, Sec 4, [4.7.3]	4.23.5.2	Ch 9, Sec 4, [10.5.2]
4.4.3	Ch 9, Sec 4, [2.2.3]	4.19	Ch 9, Sec 4, [5.1.1]	4.23.6.1	Ch 9, Sec 4, [10.6.1]
4.4.4	Ch 9, Sec 4, [2.2.4]	4.19.1.1	Ch 9, Sec 4, [5.2.1]	4.23.6.2	Ch 9, Sec 4, [10.6.2]
4.4.5	Ch 9, Sec 4, [2.2.5]	4.19.1.2	Ch 9, Sec 4, [5.2.2]	4.23.6.3	Ch 9, Sec 4, [10.6.3]
4.5	Ch 9, Sec 4, [2.3.1]	4.19.1.4	Ch 9, Sec 4, [5.2.3]	4.23.6.4	Ch 9, Sec 4, [10.6.4]
4.6.1	Ch 9, Sec 4, [2.4.2]	4.19.1.5	Ch 9, Sec 4, [5.2.5]	4.23.6.5	Ch 9, Sec 4, [10.6.5]
4.6.2	Ch 9, Sec 4, [2.4.3]	4.19.1.6	Ch 9, Sec 4, [5.2.6]	4.23.6.6	Ch 9, Sec 4, [10.6.6]
4.7.1	Ch 9, Sec 4, [2.5.1]	4.19.2.1	Ch 9, Sec 4, [5.3.1]	4.23.6.7	Ch 9, Sec 4, [10.6.7]

Ref. in IGC Code, Chapter 4	Ref. in Part D, Chapter 9
4.7.2	Ch 9, Sec 4, [2.5.2]
4.7.3	Ch 9, Sec 4, [2.5.3]
4.8.1	Ch 9, Sec 4, [7.1.1]
4.8.2	Ch 9, Sec 4, [7.4.8], a)
4.8.3	Ch 9, Sec 4, [7.1.2]
4.9	Ch 9, Sec 4, [2.7.1]
4.10.1	Ch 9, Sec 4, [2.8.1]
4.10.2	Ch 9, Sec 4, [2.8.2]
4.11	Ch 9, Sec 4, [3.1.1]
4.12.1	Ch 9, Sec 4, [3.2.1]
4.12.2	Ch 9, Sec 4, [3.2.2]
4.13.1	Ch 9, Sec 4, [3.3.1]
4.13.2	Ch 9, Sec 4, [3.3.2]
4.13.3	Ch 9, Sec 4, [3.3.3]
4.13.4	Ch 9, Sec 4, [3.3.4]
4.13.5	Ch 9, Sec 4, [3.3.5]
4.13.6	Ch 9, Sec 4, [3.3.6]
4.13.7	Ch 9, Sec 4, [3.3.7]
4.13.8	Ch 9, Sec 4, [3.3.8]
4.13.9	Ch 9, Sec 4, [3.3.9]
4.13.10	Ch 9, Sec 4, [3.3.10]
4.14	Ch 9, Sec 4, [3.4.1]
4.14.1.1	Ch 9, Sec 4, [3.4.2], a)
4.14.1.2	Ch 9, Sec 4, [3.4.2], b)
4.14.1.3	Ch 9, Sec 4, [3.4.2], c)
4.14.1.4	Ch 9, Sec 4, [3.4.2], d)
4.14.1.5	Ch 9, Sec 4, [3.4.2], e)
4.14.2	Ch 9, Sec 4, [3.4.3]
4.14.3	Ch 9, Sec 4, [3.4.4]
4.14.4	Ch 9, Sec 4, [3.4.5]
4.14.5	Ch 9, Sec 4, [3.4.6]
4.15	Ch 9, Sec 4, [3.5.1]
4.15.1	Ch 9, Sec 4, [3.5.2]
4.15.2	Ch 9, Sec 4, [3.5.3]
4.16.1	Ch 9, Sec 4, [4.1.1]
4.16.2	Ch 9, Sec 4, [4.1.2]
4.16.3	Ch 9, Sec 4, [4.1.3]
4.17.1.1	Ch 9, Sec 4, [4.2.1], a)
4.17.1.2	Ch 9, Sec 4, [4.2.1], b)
4.17.1.3	Ch 9, Sec 4, [4.2.1], c)
4.17.2.1	Ch 9, Sec 4, [4.2.2], a)
4.17.2.2	Ch 9, Sec 4, [4.2.2], b)
4.17.3	Ch 9, Sec 4, [4.2.3]
4.18	Ch 9, Sec 4, [4.4.1]
4.18.1	Ch 9, Sec 4, [4.5.1]
4.18.1.1	Ch 9, Sec 4, [4.5.1], a)
4.18.1.2	Ch 9, Sec 4, [4.5.1], b)
4.18.1.3	Ch 9, Sec 4, [4.5.1], c)
4.18.1.4	Ch 9, Sec 4, [4.5.1], d)
4.18.1.5	Ch 9, Sec 4, [4.5.1], e)

Ref. in IGC Code, Chapter 4	Ref. in Part D, Chapter 9
4.19.2.2	Ch 9, Sec 4, [5.3.2]
4.19.2.3	Ch 9, Sec 4, [5.3.3]
4.19.2.4	Ch 9, Sec 4, [5.3.4]
4.19.2.5.1	Ch 9, Sec 4, [5.3.5]
4.19.2.5.2	Ch 9, Sec 4, [5.3.6]
4.19.2.6	Ch 9, Sec 4, [5.3.7]
4.19.3.1	Ch 9, Sec 4, [5.4.1]
4.19.3.2	Ch 9, Sec 4, [5.4.2]
4.19.3.3	Ch 9, Sec 4, [5.4.3]
4.19.3.4	Ch 9, Sec 4, [5.4.4]
4.19.3.5	Ch 9, Sec 4, [5.4.5]
4.19.3.6	Ch 9, Sec 4, [5.4.6]
4.19.3.7	Ch 9, Sec 4, [5.4.7]
4.20	Ch 9, Sec 4, [6.1.1]
4.20.1.1	Ch 9, Sec 4, [6.2.1]
4.20.1.2	Ch 9, Sec 4, [6.2.2]
4.20.1.3	Ch 9, Sec 4, [6.2.3]
4.20.2	Ch 9, Sec 4, [6.3.1]
4.20.3.1	Ch 9, Sec 4, [6.4.1]
4.20.3.2	Ch 9, Sec 4, [6.4.2]
4.20.3.3	Ch 9, Sec 4, [6.4.3]
4.20.3.4	Ch 9, Sec 4, [6.4.5]
4.20.3.5	Ch 9, Sec 4, [6.4.6]
4.20.3.6	Ch 9, Sec 4, [6.4.7]
4.20.3.7	Ch 9, Sec 4, [6.4.8]
4.21.1.1	Ch 9, Sec 4, [8.1.1]
4.21.1.2	Ch 9, Sec 4, [8.1.2]
4.21.2.1	Ch 9, Sec 4, [8.2.1]
4.21.2.2	Ch 9, Sec 4, [7.4.1]
4.21.2.3	Ch 9, Sec 4, [7.4.2]
4.21.3.1	Ch 9, Sec 4, [8.3.1]
4.21.3.2	Ch 9, Sec 4, [8.3.2]
4.21.3.3	Ch 9, Sec 4, [8.3.6]
4.21.4.1	Ch 9, Sec 4, [8.4.1]
4.21.4.2	Ch 9, Sec 4, [8.4.2]
4.21.5	Ch 9, Sec 4, [8.5.1]
4.22.1.1	Ch 9, Sec 4, [9.1.1]
4.22.1.2	Ch 9, Sec 4, [9.1.2]
4.22.2.1	Ch 9, Sec 4, [9.2.1]
4.22.2.2	Ch 9, Sec 4, [9.2.2]
4.22.2.3	Ch 9, Sec 4, [9.2.5]
4.22.3.1.1	Ch 9, Sec 4, [9.3.2], a)
4.22.3.1.2	Ch 9, Sec 4, [9.3.2], b)
4.22.3.1.3	Ch 9, Sec 4, [9.3.1]
4.22.3.2	Ch 9, Sec 4, [9.3.3]
4.22.4.1	Ch 9, Sec 4, [9.4.1]
4.22.4.2	Ch 9, Sec 4, [9.4.2]
4.22.4.3	Ch 9, Sec 4, [9.4.3]
4.22.5.1	Ch 9, Sec 4, [9.5.1]
4.22.5.2	Ch 9, Sec 4, [9.5.2]

Ref. in IGC Code, Chapter 4	Ref. in Part D, Chapter 9
4.23.7	Ch 9, Sec 4, [10.7.1]
4.24.1.1	NR686, Sec 1, [24.1.1]
4.24.1.2	NR686, Sec 1, [24.1.2]
4.24.1.3	Ch 9, Sec 4, [11.1.2]
4.24.1.4	NR686, Sec 1, [24.1.3]
4.24.1.5	NR686, Sec 1, [24.1.4]
4.24.1.6	NR686, Sec 1, [24.1.5]
4.24.1.7	NR686, Sec 1, [24.1.6]
4.24.2.1	NR686, Sec 1, [24.2.1]
4.24.2.2	NR686, Sec 1, [24.2.2]
4.24.3	NR686, Sec 1, [24.3.1]
4.24.4.1	NR686, Sec 1, [24.4.1]
4.24.4.2	NR686, Sec 1, [24.4.2]
4.24.4.3	NR686, Sec 1, [24.4.3]
4.24.5.1	NR686, Sec 1, [24.5.1]
4.24.5.2	NR686, Sec 1, [24.5.2]
4.24.5.3	NR686, Sec 1, [24.5.3]
4.24.6.1	NR686, Sec 1, [24.6.1]
4.24.6.2	NR686, Sec 1, [24.6.2]
4.24.6.3	NR686, Sec 1, [24.6.3]
4.24.6.4	NR686, Sec 1, [24.6.4]
4.24.6.5	NR686, Sec 1, [24.6.5]
4.24.7.1	NR686, Sec 1, [24.7.1]
4.24.7.2	NR686, Sec 1, [24.7.2]
4.24.8.1	NR686, Sec 1, [24.8.1]
4.24.8.2	NR686, Sec 1, [24.8.2]
4.24.9.1	NR686, Sec 1, [24.9.1]
4.24.9.2	NR686, Sec 1, [24.9.2]
4.24.9.3	NR686, Sec 1, [24.9.3]
4.25.1	Ch 9, Sec 4, [12.1.1]
4.25.2	Ch 9, Sec 4, [12.2.1]
4.25.3.1	Ch 9, Sec 4, [12.3.1]
4.25.3.2	Ch 9, Sec 4, [12.3.2]
4.25.4.1	Ch 9, Sec 4, [12.4.1]
4.25.4.2	Ch 9, Sec 4, [12.4.2]
4.25.5	Ch 9, Sec 4, [12.5.1]
4.26.1.1	Ch 9, Sec 4, [13.1.1]
4.26.1.2	Ch 9, Sec 4, [13.1.2]
4.26.1.3	Ch 9, Sec 4, [13.1.3]
4.26.1.4	Ch 9, Sec 4, [13.1.4]
4.27.1	Ch 9, Sec 4, [14.1.1]
4.27.2	Ch 9, Sec 4, [14.1.2]
4.27.3	Ch 9, Sec 4, [14.1.3]
4.27.4	Ch 9, Sec 4, [14.1.4]
4.28.1.1	Ch 9, App 1, [1.1.1]
4.28.1.2	Ch 9, App 1, [1.1.2]
4.28.1.3	Ch 9, App 1, [1.1.2]
4.28.2.1	Ch 9, App 1, [1.2.1]
4.28.3	Ch 9, Sec 4, [4.3.1]

Table 5 : Equivalences between Part D, Chapter 9 and Chapter 5 of the IGC Code

Ref. in IGC Code, Chapter 5	Ref. in Part D, Chapter 9	Ref. in IGC Code, Chapter 5	Ref. in Part D, Chapter 9	Ref. in IGC Code, Chapter 5	Ref. in Part D, Chapter 9
5.1.1	Ch 9, Sec 5, [1.1.1]	5.6.2	Ch 9, Sec 5, [6.1.3]	5.11.2.2	Ch 9, Sec 5, [11.2.2]
5.1.2	Ch 9, Sec 5, [1.1.3]	5.6.3	Ch 9, Sec 5, [6.2.1]	5.11.2.3	Ch 9, Sec 5, [11.2.4]
5.1.3	Ch 9, Sec 5, [1.1.4]	5.6.4	Ch 9, Sec 5, [6.3.1]	5.11.2.4	Ch 9, Sec 5, [11.2.5]
5.2.1	Ch 9, Sec 5, [2.1.3]	5.6.5.1	Ch 9, Sec 5, [6.4.1]	5.11.3	Ch 9, Sec 5, [11.3.1]
5.2.2.1	Ch 9, Sec 5, [2.2.1]	5.6.5.2	Ch 9, Sec 5, [6.4.2]	5.11.4	Ch 9, Sec 5, [11.4.1]
5.2.2.2	Ch 9, Sec 5, [2.2.2]	5.6.5.3	Ch 9, Sec 5, [6.4.3]	5.11.5	Ch 9, Sec 5, [11.5.1]
5.2.2.3	Ch 9, Sec 5, [2.2.3]	5.6.5.4	Ch 9, Sec 5, [6.4.4]	5.11.6.1	Ch 9, Sec 5, [11.6.1]
5.2.2.4	Ch 9, Sec 5, [2.2.4]	5.6.5.5	Ch 9, Sec 5, [6.4.5]	5.11.6.2	Ch 9, Sec 5, [11.6.2]
5.3.1	Ch 9, Sec 5, [3.1.1]	5.6.5.6	Ch 9, Sec 5, [6.4.6]	5.11.6.3	Ch 9, Sec 5, [11.6.4]
5.3.2.1	Ch 9, Sec 5, [3.2.1]	5.6.6	Ch 9, Sec 5, [6.5.1]	5.11.6.4	Ch 9, Sec 5, [11.6.5]
5.3.2.2	Ch 9, Sec 5, [3.2.2]	5.7.1	Ch 9, Sec 5, [7.1.1]	5.11.7.1	Ch 9, Sec 5, [11.7.3]
5.3.3	Ch 9, Sec 5, [3.3.1]	5.7.2	Ch 9, Sec 5, [7.2.1]	5.11.7.2	Ch 9, Sec 5, [11.7.4]
5.3.4	Ch 9, Sec 5, [3.4.1]	5.7.3	Ch 9, Sec 5, [7.3.1]	5.11.7.3	Ch 9, Sec 5, [11.7.5]
5.4.1	Ch 9, Sec 5, [4.1.1]	5.7.4	Ch 9, Sec 5, [7.4.1]	5.12.1	Ch 9, Sec 5, [12.1.1]
5.4.2	Ch 9, Sec 5, [4.1.2]	5.8.1	Ch 9, Sec 5, [8.1.1]	5.12.2	Ch 9, Sec 5, [12.1.2]
5.4.3	Ch 9, Sec 5, [4.1.3]	5.8.2	Ch 9, Sec 5, [8.2.1]	5.12.3.1	Ch 9, Sec 5, [12.1.4]
5.4.4	Ch 9, Sec 5, [4.1.4]	5.8.3.1	Ch 9, Sec 5, [8.3.1]	5.12.3.2	Ch 9, Sec 5, [12.1.4]
5.5.1.1	Ch 9, Sec 5, [5.1.1]	5.8.3.2	Ch 9, Sec 5, [8.3.2]	5.12.4	Ch 9, Sec 5, [12.1.5]
5.5.1.2	Ch 9, Sec 5, [5.1.1]	5.8.4	Ch 9, Sec 5, [8.4.1]	5.13.1.1	Ch 9, Sec 5, [13.3.1]
5.5.2.1	Ch 9, Sec 5, [5.1.2]	5.8.5	Ch 9, Sec 5, [8.5.1]	5.13.1.2	Ch 9, Sec 5, [13.4.1]
5.5.2.2	Ch 9, Sec 5, [5.1.2]	5.9.1	Ch 9, Sec 5, [9.1.1]	5.13.2.1	Ch 9, Sec 5, [13.5.1]
5.5.3.1	Ch 9, Sec 5, [5.2.1]	5.9.2	Ch 9, Sec 5, [9.2.1]	5.13.2.2	Ch 9, Sec 5, [13.5.2]
5.5.3.2	Ch 9, Sec 5, [5.2.2]	5.9.3	Ch 9, Sec 5, [9.3.1]	5.13.2.3	Ch 9, Sec 5, [13.5.3]
5.5.4	Ch 9, Sec 5, [5.3.1]	5.10.1	Ch 9, Sec 5, [10.1.1]	5.13.2.4	Ch 9, Sec 5, [13.5.4]
5.5.5	Ch 9, Sec 5, [5.3.2]	5.10.2	Ch 9, Sec 5, [10.2.1]	5.13.2.5	Ch 9, Sec 5, [13.5.5]
5.5.6	Ch 9, Sec 5, [5.3.3]	5.10.3	Ch 9, Sec 5, [10.3.1]	5.13.3	Ch 9, Sec 5, [13.6.1]
5.5.7	Ch 9, Sec 5, [5.3.4]	5.11.1	Ch 9, Sec 5, [11.1.1]		
5.6.1	Ch 9, Sec 5, [6.1.2]	5.11.2.1	Ch 9, Sec 5, [11.2.1]		

Table 6 : Equivalences between Part D, Chapter 9 and Chapter 6 of the IGC Code

Ref. in IGC Code, Chapter 6	Ref. in Part D, Chapter 9	Ref. in IGC Code, Chapter 6	Ref. in Part D, Chapter 9	Ref. in IGC Code, Chapter 6	Ref. in Part D, Chapter 9
6.1.1	Ch 9, Sec 6, [1.1.1]	6.3.4	Ch 9, Sec 6, [3.4.1]	6.5.6.2	Ch 9, Sec 6, [5.6.3]
6.1.2	Ch 9, Sec 6, [1.1.2]	6.4.1.1	Ch 9, Sec 6, [4.1.3]	6.5.6.3	Ch 9, Sec 6, [5.6.4]
6.1.3	Ch 9, Sec 6, [1.1.3]	6.5.1.1	Ch 9, Sec 6, [5.1.1]	6.5.6.4	Ch 9, Sec 6, [5.6.5]
6.1.4	Ch 9, Sec 6, [1.1.4]	6.5.2.1	Ch 9, Sec 6, [5.2.1]	6.5.6.5	Ch 9, Sec 6, [5.6.6]
6.1.5	Ch 9, Sec 6, [1.1.5]	6.5.3.1	Ch 9, Sec 6, [5.3.1]	6.5.6.6	Ch 9, Sec 6, [5.6.7]
6.1.6	Ch 9, Sec 6, [1.1.6]	6.5.3.2	Ch 9, Sec 6, [5.3.2]	6.5.6.7	Ch 9, Sec 6, [5.6.8]
6.2.1	Ch 9, Sec 6, [2.1.1]	6.5.3.3	Ch 9, Sec 6, [5.3.3]	6.5.6.8	Ch 9, Sec 6, [5.6.9]
6.2.2	Ch 9, Sec 6, [2.1.2]	6.5.3.4	Ch 9, Sec 6, [5.3.4]	6.6.1.1	Ch 9, Sec 6, [6.1.1]
6.2.3	Ch 9, Sec 6, [2.1.3]	6.5.3.5	Ch 9, Sec 6, [5.3.5]	6.6.2.1	Ch 9, Sec 6, [6.2.1]
6.3.1.1	Ch 9, Sec 6, [3.1.1]	6.5.3.6	Ch 9, Sec 6, [5.3.6]	6.6.2.2	Ch 9, Sec 6, [6.2.2]
6.3.1.2	Ch 9, Sec 6, [3.1.2]	6.5.4	Ch 9, Sec 6, [5.4.1]	6.6.2.3	Ch 9, Sec 6, [6.2.3]
6.3.2.1	Ch 9, Sec 6, [3.2.1]	6.5.5.1	Ch 9, Sec 6, [5.5.1]	6.6.3	Ch 9, Sec 6, [6.3.1]
6.3.2.2	Ch 9, Sec 6, [3.2.2]	6.5.5.2	Ch 9, Sec 6, [5.5.2]	6.6.4	Ch 9, Sec 6, [6.4.1]
6.3.2.3	Ch 9, Sec 6, [3.2.3]	6.5.5.3	Ch 9, Sec 6, [5.5.3]	6.6.5	Ch 9, Sec 6, [6.5.1]
6.3.2.4	Ch 9, Sec 6, [3.2.4]	6.5.5.4	Ch 9, Sec 6, [5.5.4]	6.7.1	Ch 9, Sec 6, [7.1.1]
6.3.3.1	Ch 9, Sec 6, [3.3.1]	6.5.5.5	Ch 9, Sec 6, [5.5.5]		
6.3.3.2	Ch 9, Sec 6, [3.3.2]	6.5.6.1	Ch 9, Sec 6, [5.6.2]		

Table 7 : Equivalences between Part D, Chapter 9 and Chapter 7 of the IGC Code

Ref. in IGC Code, Chapter 7	Ref. in Part D, Chapter 9	Ref. in IGC Code, Chapter 7	Ref. in Part D, Chapter 9	Ref. in IGC Code, Chapter 7	Ref. in Part D, Chapter 9
7.1.1	Ch 9, Sec 7, [1.1.1]	7.4.2	Ch 9, Sec 7, [4.2.1]	7.5	Ch 9, Sec 7, [5.1.1]
7.1.2	Ch 9, Sec 7, [1.1.2]	7.4.3	Ch 9, Sec 7, [4.3.1]	7.6	Ch 9, Sec 7, [6.1.1]
7.1.3	Ch 9, Sec 7, [1.1.3]	7.4.4.1	Ch 9, Sec 7, [4.4.1]	7.7	Ch 9, Sec 7, [7.1.1]
7.2	Ch 9, Sec 7, [2.1.1]	7.4.4.2	Ch 9, Sec 7, [4.4.2]	7.8.1	Ch 9, Sec 7, [8.1.1], a)
7.3.1	Ch 9, Sec 7, [3.1.3]	7.4.4.3	Ch 9, Sec 7, [4.4.3]	7.8.2	Ch 9, Sec 7, [8.1.1], b)
7.3.2	Ch 9, Sec 7, [3.1.4]	7.4.4.4	Ch 9, Sec 7, [4.4.4]	7.8.3	Ch 9, Sec 7, [8.1.1], c)
7.4.1	Ch 9, Sec 7, [4.1.2]	7.4.4.5	Ch 9, Sec 7, [4.4.5]	7.8.4	Ch 9, Sec 7, [8.1.1], d)

Table 8 : Equivalences between Part D, Chapter 9 and Chapter 8 of the IGC Code

Ref. in IGC Code, Chapter 8	Ref. in Part D, Chapter 9	Ref. in IGC Code, Chapter 8	Ref. in Part D, Chapter 9	Ref. in IGC Code, Chapter 8	Ref. in Part D, Chapter 9
8.1	Ch 9, Sec 8, [1.1.1]	8.2.11.1	Ch 9, Sec 8, [2.1.14]	8.4.1	Ch 9, Sec 8, [4.1.1]
8.2.1	Ch 9, Sec 8, [2.1.1]	8.2.11.2	Ch 9, Sec 8, [2.1.14]	8.4.1.1	Ch 9, Sec 8, [4.1.1], a)
8.2.2	Ch 9, Sec 8, [2.1.2]	8.2.12	Ch 9, Sec 8, [2.1.15]	8.4.1.2	Ch 9, Sec 8, [4.1.1], b)
8.2.3	Ch 9, Sec 8, [2.1.5]	8.2.13	Ch 9, Sec 8, [2.1.6]	8.4.1.3	Ch 9, Sec 8, [4.1.1], b)
8.2.4	Ch 9, Sec 8, [2.1.6]	8.2.14	Ch 9, Sec 8, [2.1.17]	8.4.2	Ch 9, Sec 8, [4.2.1]
8.2.5.1	Ch 9, Sec 8, [2.1.7], a)	8.2.15	Ch 9, Sec 8, [2.1.18]	8.4.3.1	Ch 9, Sec 8, [4.3.1]
8.2.5.2	Ch 9, Sec 8, [2.1.7], b)	8.2.16	Ch 9, Sec 8, [2.1.19]	8.4.3.2	Ch 9, Sec 8, [4.3.2]
8.2.6	Ch 9, Sec 8, [2.1.8]	8.2.17	Ch 9, Sec 8, [2.1.20]	8.4.3.3	Ch 9, Sec 8, [4.3.3]
8.2.7	Ch 9, Sec 8, [2.1.9]	8.2.18	Ch 9, Sec 8, [2.1.21]	8.4.4.1	Ch 9, Sec 8, [4.4.1]
8.2.8	Ch 9, Sec 8, [2.1.10]	8.3.1	Ch 9, Sec 8, [3.1.1]	8.4.4.2	Ch 9, Sec 8, [4.4.2]
8.2.9	Ch 9, Sec 8, [2.1.11]	8.3.2	Ch 9, Sec 8, [3.1.2]	8.4.5	Ch 9, Sec 8, [4.5.1]
8.2.10	Ch 9, Sec 8, [2.1.12]	8.3.3	Ch 9, Sec 8, [3.1.3]		

Table 9 : Equivalences between Part D, Chapter 9 and Chapter 9 of the IGC Code

Ref. in IGC Code, Chapter 9	Ref. in Part D, Chapter 9	Ref. in IGC Code, Chapter 9	Ref. in Part D, Chapter 9	Ref. in IGC Code, Chapter 9	Ref. in Part D, Chapter 9
9.1.1	Ch 9, Sec 9, [1.1.1]	9.2.3	Ch 9, Sec 9, [1.2.3]	9.4.6	Ch 9, Sec 9, [1.4.7]
9.1.2	Ch 9, Sec 9, [1.1.2]	9.3	Ch 9, Sec 9, [1.3.1]	9.5.1	Ch 9, Sec 9, [1.5.3]
9.1.3	Ch 9, Sec 9, [1.1.3]	9.4.1	Ch 9, Sec 9, [1.4.1]	9.5.2	Ch 9, Sec 9, [1.5.4]
9.1.4	Ch 9, Sec 9, [1.1.4]	9.4.2	Ch 9, Sec 9, [1.4.3]	9.5.3	Ch 9, Sec 9, [1.5.5]
9.1.5	Ch 9, Sec 9, [1.1.5]	9.4.3	Ch 9, Sec 9, [1.4.4]	9.5.4	Ch 9, Sec 9, [1.5.6]
9.2.1	Ch 9, Sec 9, [1.2.1]	9.4.4	Ch 9, Sec 9, [1.4.5]		
9.2.2	Ch 9, Sec 9, [1.2.2]	9.4.5	Ch 9, Sec 9, [1.4.6]		

Table 10 : Equivalences between Part D, Chapter 9 and Chapter 10 of the IGC Code

Ref. in IGC Code, Chapter 10	Ref. in Part D, Chapter 9	Ref. in IGC Code, Chapter 10	Ref. in Part D, Chapter 9	Ref. in IGC Code, Chapter 10	Ref. in Part D, Chapter 9
10.1	Ch 9, Sec 10, [1.3.1]	10.1.2	Ch 9, Sec 10, [1.3.6]	10.2.5	Ch 9, Sec 10, [1.4.6]
10.1.1	Ch 9, Sec 10, [1.3.2]	10.2.1	Ch 9, Sec 10, [1.4.1]	10.2.6	Ch 9, Sec 10, [1.4.7]
10.1.1.1	Ch 9, Sec 10, [1.3.3]	10.2.2	Ch 9, Sec 10, [1.4.3]	10.2.7	Ch 9, Sec 10, [1.4.8]
10.1.1.2	Ch 9, Sec 10, [1.3.4]	10.2.3	Ch 9, Sec 10, [1.4.4]	10.2.8	Ch 9, Sec 10, [1.4.9]
10.1.1.3	Ch 9, Sec 10, [1.3.5]	10.2.4	Ch 9, Sec 10, [1.4.5]	10.2.9	Ch 9, Sec 10, [1.4.10]

Table 11 : Equivalences between Part D, Chapter 9 and Chapter 11 of the IGC Code

Ref. in IGC Code, Chapter 11	Ref. in Part D, Chapter 9	Ref. in IGC Code, Chapter 11	Ref. in Part D, Chapter 9	Ref. in IGC Code, Chapter 11	Ref. in Part D, Chapter 9
11.1.1	Ch 9, Sec 11, [1.1.1]	11.3.2.2	Ch 9, Sec 11, [1.3.4]	11.4.5	Ch 9, Sec 11, [1.4.6]
11.1.2	Ch 9, Sec 11, [1.1.2]	11.3.3	Ch 9, Sec 11, [1.3.5]	11.4.6	Ch 9, Sec 11, [1.4.7]
11.1.3	Ch 9, Sec 11, [1.1.4]	11.3.4	Ch 9, Sec 11, [1.3.6]	11.4.7	Ch 9, Sec 11, [1.4.8]
11.1.4	Ch 9, Sec 11, [1.1.5]	11.3.5	Ch 9, Sec 11, [1.3.7]	11.4.8	Ch 9, Sec 11, [1.4.9]
11.2.1	Ch 9, Sec 11, [1.2.1]	11.3.6	Ch 9, Sec 11, [1.3.8]	11.5.1	Ch 9, Sec 11, [1.5.2]
11.2.2	Ch 9, Sec 11, [1.2.2]	11.3.7	Ch 9, Sec 11, [1.3.9]	11.5.2	Ch 9, Sec 11, [1.5.4]
11.2.3	Ch 9, Sec 11, [1.2.3]	11.3.8	Ch 9, Sec 11, [1.3.10]	11.5.3	Ch 9, Sec 11, [1.5.5]
11.2.4	Ch 9, Sec 11, [1.2.4]	11.4.1	Ch 9, Sec 11, [1.4.1]	11.6.1	Ch 9, Sec 11, [1.6.1]
11.2.5	Ch 9, Sec 11, [1.2.5]	11.4.2	Ch 9, Sec 11, [1.4.2]	11.6.2	Ch 9, Sec 11, [1.6.2]
11.3.1	Ch 9, Sec 11, [1.3.2]	11.4.3	Ch 9, Sec 11, [1.4.3]	11.6.3	Ch 9, Sec 11, [1.6.3]
11.3.2.1	Ch 9, Sec 11, [1.3.3]	11.4.4	Ch 9, Sec 11, [1.4.5]		

Table 12 : Equivalences between Part D, Chapter 9 and Chapter 12 of the IGC Code

Ref. in IGC Code, Chapter 12	Ref. in Part D, Chapter 9	Ref. in IGC Code, Chapter 12	Ref. in Part D, Chapter 9	Ref. in IGC Code, Chapter 12	Ref. in Part D, Chapter 9
Scope	Ch 9, Sec 12, [1.1.1]	12.1.5	Ch 9, Sec 12, [1.2.5]	12.1.10	Ch 9, Sec 12, [1.2.16]
12.1.1	Ch 9, Sec 12, [1.2.1]	12.1.6	Ch 9, Sec 12, [1.2.11]	12.2.1	Ch 9, Sec 12, [1.3.2]
12.1.2	Ch 9, Sec 12, [1.2.2]	12.1.7	Ch 9, Sec 12, [1.2.12]	12.2.2	Ch 9, Sec 12, [1.3.3]
12.1.3	Ch 9, Sec 12, [1.2.3]	12.1.8	Ch 9, Sec 12, [1.2.14]	12.2.3	Ch 9, Sec 12, [1.3.4]
12.1.4	Ch 9, Sec 12, [1.2.4]	12.1.9	Ch 9, Sec 12, [1.2.15]		

Table 13 : Equivalences between Part D, Chapter 9 and Chapter 13 of the IGC Code

Ref. in IGC Code, Chapter 13	Ref. in Part D, Chapter 9	Ref. in IGC Code, Chapter 13	Ref. in Part D, Chapter 9	Ref. in IGC Code, Chapter 13	Ref. in Part D, Chapter 9
13.1.1	Ch 9, Sec 13, [1.1.3]	13.5.3	Ch 9, Sec 13, [5.1.3]	13.7.2.1	Ch 9, Sec 13, [7.2.1]
13.1.2	Ch 9, Sec 13, [1.1.4]	13.6.1	Ch 9, Sec 13, [6.1.1]	13.7.2.2	Ch 9, Sec 13, [7.2.2]
13.1.3	Ch 9, Sec 13, [1.1.6]	13.6.2	Ch 9, Sec 13, [6.1.2]	13.7.2.3	Ch 9, Sec 13, [7.2.4]
13.2.1	Ch 9, Sec 13, [2.1.1]	13.6.3	Ch 9, Sec 13, [6.1.3]	13.7.2.4	Ch 9, Sec 13, [7.2.5]
13.2.2	Ch 9, Sec 13, [2.1.2]	13.6.4	Ch 9, Sec 13, [6.1.4]	13.8.1	Ch 9, Sec 13, [8.1.1]
13.2.3	Ch 9, Sec 13, [2.1.4]	13.6.5	Ch 9, Sec 13, [6.1.5]	13.8.2	Ch 9, Sec 13, [8.1.2]
13.3.1	Ch 9, Sec 13, [3.1.1]	13.6.6	Ch 9, Sec 13, [6.1.6]	13.8.3	Ch 9, Sec 13, [8.1.3]
13.3.2	Ch 9, Sec 13, [3.1.3]	13.6.7	Ch 9, Sec 13, [6.1.7]	13.8.4	Ch 9, Sec 13, [8.1.4]
13.3.3	Ch 9, Sec 13, [3.1.4]	13.6.8	Ch 9, Sec 13, [6.1.8]	13.8.5	Ch 9, Sec 13, [8.1.5]
13.3.4	Ch 9, Sec 13, [3.1.5]	13.6.9	Ch 9, Sec 13, [6.1.9]	13.8.6	Ch 9, Sec 13, [8.1.6]
13.3.5	Ch 9, Sec 13, [3.1.6]	13.6.10	Ch 9, Sec 13, [6.1.10]	13.8.7	Ch 9, Sec 13, [8.1.7]
13.3.6	Ch 9, Sec 13, [3.1.7]	13.6.11	Ch 9, Sec 13, [6.1.11]	13.8.8	Ch 9, Sec 13, [8.1.8]
13.3.7	Ch 9, Sec 13, [3.1.8]	13.6.12	Ch 9, Sec 13, [6.1.12]	13.8.9	Ch 9, Sec 13, [8.1.9]
13.4.1	Ch 9, Sec 13, [4.1.1]	13.6.13	Ch 9, Sec 13, [6.1.13]	13.8.10	Ch 9, Sec 13, [8.1.10]
13.4.2	Ch 9, Sec 13, [4.1.2]	13.6.14	Ch 9, Sec 13, [6.1.14]	13.9.1	Ch 9, Sec 13, [9.1.1]
13.4.3	Ch 9, Sec 13, [4.1.3]	13.6.15	Ch 9, Sec 13, [6.1.15]	13.9.2	Ch 9, Sec 13, [9.1.2]
13.4.4	Ch 9, Sec 13, [4.1.4]	13.6.16	Ch 9, Sec 13, [6.1.16]	13.9.3	Ch 9, Sec 13, [9.1.3]
13.4.5	Ch 9, Sec 13, [4.1.5]	13.6.17	Ch 9, Sec 13, [6.1.17]	13.9.4	Ch 9, Sec 13, [9.1.4]
13.4.6	Ch 9, Sec 13, [4.1.6]	13.6.18	Ch 9, Sec 13, [6.1.18]	13.9.5	Ch 9, Sec 13, [9.1.5]
13.4.7	Ch 9, Sec 13, [4.1.7]	13.6.19	Ch 9, Sec 13, [6.1.19]	13.9.6	Ch 9, Sec 13, [9.1.6]
13.5.1	Ch 9, Sec 13, [5.1.1]	13.6.20	Ch 9, Sec 13, [6.1.20]	13.9.7	Ch 9, Sec 13, [9.1.7]
13.5.2	Ch 9, Sec 13, [5.1.2]	13.7.1	Ch 9, Sec 13, [7.1.1]		

Table 14 : Equivalences between Part D, Chapter 9 and Chapter 14 of the IGC Code

Ref. in IGC Code, Chapter 14	Ref. in Part D, Chapter 9	Ref. in IGC Code, Chapter 14	Ref. in Part D, Chapter 9	Ref. in IGC Code, Chapter 14	Ref. in Part D, Chapter 9
14.1.1	Ch 9, Sec 14, [1.1.1]	14.2.2	Ch 9, Sec 14, [1.2.2]	14.4.1	Ch 9, Sec 14, [1.4.1]
14.1.2	Ch 9, Sec 14, [1.1.2]	14.3.1	Ch 9, Sec 14, [1.3.1]	14.4.2	Ch 9, Sec 14, [1.4.2]
14.1.3	Ch 9, Sec 14, [1.1.3]	14.3.2	Ch 9, Sec 14, [1.3.2]	14.4.3	Ch 9, Sec 14, [1.4.3]
14.2.1	Ch 9, Sec 14, [1.2.1]	14.3.3	Ch 9, Sec 14, [1.3.3]	14.4.4	Ch 9, Sec 14, [1.4.5]

Table 15 : Equivalences between Part D, Chapter 9 and Chapter 15 of the IGC Code

Ref. in IGC Code, Chapter 15	Ref. in Part D, Chapter 9	Ref. in IGC Code, Chapter 15	Ref. in Part D, Chapter 9	Ref. in IGC Code, Chapter 15	Ref. in Part D, Chapter 9
15.1.1	Ch 9, Sec 15, [1.1.1]	15.3	Ch 9, Sec 15, [1.3.1]	15.6.1	Ch 9, Sec 15, [1.6.1]
15.1.2	Ch 9, Sec 15, [1.1.2]	15.4.1	Ch 9, Sec 15, [1.4.1]	15.6.2	Ch 9, Sec 15, [1.6.2]
15.1.3	Ch 9, Sec 15, [1.1.3]	15.4.2	Ch 9, Sec 15, [1.4.2]	15.6.3	Ch 9, Sec 15, [1.6.3]
15.1.4	Ch 9, Sec 15, [1.1.4]	15.5.1	Ch 9, Sec 15, [1.5.1]		
15.2	Ch 9, Sec 15, [1.2.1]	15.5.2	Ch 9, Sec 15, [1.5.2]		

Table 16 : Equivalences between Part D, Chapter 9 and Chapter 16 of the IGC Code

Ref. in IGC Code, Chapter 16	Ref. in Part D, Chapter 9	Ref. in IGC Code, Chapter 16	Ref. in Part D, Chapter 9	Ref. in IGC Code, Chapter 16	Ref. in Part D, Chapter 9
16.1	Ch 9, Sec 16, [1.1.1]	16.5.2.2	Ch 9, Sec 16, [5.2.2]	16.7.2.1	Ch 9, Sec 16, [7.7.1]
16.2	Ch 9, Sec 16, [2.1.1]	16.5.3	Ch 9, Sec 16, [5.4.1]	16.7.2.2	Ch 9, Sec 16, [7.7.2]
16.2.1	Ch 9, Sec 16, [2.1.2]	16.5.4	Ch 9, Sec 16, [5.5.1]	16.7.2.3	Ch 9, Sec 16, [7.7.3]
16.2.2	Ch 9, Sec 16, [2.1.3]	16.6.1.1	Ch 9, Sec 16, [6.1.1]	16.7.2.4	Ch 9, Sec 16, [7.7.4]
16.3.1	Ch 9, Sec 16, [3.1.1]	16.6.1.2	Ch 9, Sec 16, [6.1.2]	16.7.3.1	Ch 9, Sec 16, [7.8.1]
16.3.2	Ch 9, Sec 16, [3.1.2]	16.6.1.3	Ch 9, Sec 16, [6.1.4]	16.7.3.2	Ch 9, Sec 16, [7.8.2]
16.3.3	Ch 9, Sec 16, [3.1.3]	16.6.2.1	Ch 9, Sec 16, [6.2.1]	16.7.3.3	Ch 9, Sec 16, [7.8.3]
16.3.4	Ch 9, Sec 16, [3.1.4]	16.6.2.2	Ch 9, Sec 16, [6.2.2]	16.7.3.4	Ch 9, Sec 16, [7.8.4]
16.4.1.1	Ch 9, Sec 16, [4.1.1]	16.6.2.3	Ch 9, Sec 16, [6.2.3]	16.7.3.5	Ch 9, Sec 16, [7.8.5]
16.4.1.2	Ch 9, Sec 16, [4.1.5]	16.6.2.4	Ch 9, Sec 16, [6.2.4]	16.8.1.1	Ch 9, Sec 16, [8.1.1]
16.4.2	Ch 9, Sec 16, [4.2.1]	16.6.3.1	Ch 9, Sec 16, [6.3.1]	16.8.1.2	Ch 9, Sec 16, [8.1.2]
16.4.3	Ch 9, Sec 16, [4.3.1]	16.6.3.2	Ch 9, Sec 16, [6.3.2]	16.8.1.3	Ch 9, Sec 16, [8.1.3]
16.4.4.1	Ch 9, Sec 16, [4.4.1]	16.6.3.3	Ch 9, Sec 16, [6.3.3]	16.8.2	Ch 9, Sec 16, [8.2.1]
16.4.4.2	Ch 9, Sec 16, [4.4.2]	16.6.3.4	Ch 9, Sec 16, [6.3.5]	16.8.3.1	Ch 9, Sec 16, [8.3.1]
16.4.5	Ch 9, Sec 16, [4.5.1]	16.6.3.5	Ch 9, Sec 16, [6.3.6]	16.8.3.2	Ch 9, Sec 16, [8.3.2]
16.4.6.1	Ch 9, Sec 16, [4.6.1]	16.6.3.6	Ch 9, Sec 16, [6.3.7]	16.9.1	Ch 9, Sec 16, [9.1.1]
16.4.6.2	Ch 9, Sec 16, [4.6.2]	16.7	Ch 9, Sec 16, [7.1.1]	16.9.2	Ch 9, Sec 16, [9.1.2]
16.4.6.3	Ch 9, Sec 16, [4.6.3]	16.7.1.1	Ch 9, Sec 16, [7.6.1]	16.9.3	Ch 9, Sec 16, [9.1.3]
16.4.7	Ch 9, Sec 16, [4.7.1]	16.7.1.2	Ch 9, Sec 16, [7.6.2]	16.9.4	Ch 9, Sec 16, [9.1.4]
16.4.8	Ch 9, Sec 16, [4.8.1]	16.7.1.3	Ch 9, Sec 16, [7.6.3]	16.9.5	Ch 9, Sec 16, [9.1.5]
16.5.1	Ch 9, Sec 16, [5.1.1]	16.7.1.4	Ch 9, Sec 16, [7.6.4]		
16.5.2.1	Ch 9, Sec 16, [5.2.1]	16.7.1.5	Ch 9, Sec 16, [7.6.5]		

Table 17 : Equivalences between Part D, Chapter 9 and Chapter 17 of the IGC Code

Ref. in IGC Code, Chapter 17	Ref. in Part D, Chapter 9	Ref. in IGC Code, Chapter 17	Ref. in Part D, Chapter 9	Ref. in IGC Code, Chapter 17	Ref. in Part D, Chapter 9
17.1	Ch 9, Sec 17, [1.1.1]	17.13.2.1	Ch 9, Sec 17, [13.2.1]	17.18.7	Ch 9, Sec 17, [18.1.7]
17.2	Ch 9, Sec 17, [2.1.1]	17.13.2.2	Ch 9, Sec 17, [13.2.2]	17.18.8	Ch 9, Sec 17, [18.1.8]
17.3.1	Ch 9, Sec 17, [3.1.1]	17.13.2.3	Ch 9, Sec 17, [13.2.4]	17.18.9	Ch 9, Sec 17, [18.1.9]
17.3.2	Ch 9, Sec 17, [3.1.2]	17.13.3.1	Ch 9, Sec 17, [13.3.1]	17.18.10	Ch 9, Sec 17, [18.1.10]
17.4.1	Ch 9, Sec 17, [4.1.1]	17.13.3.2	Ch 9, Sec 17, [13.3.2]	17.18.11	Ch 9, Sec 17, [18.1.11]
17.4.2	Ch 9, Sec 17, [4.1.2]	17.13.4.1	Ch 9, Sec 17, [13.4.1]	17.18.12	Ch 9, Sec 17, [18.1.12]
17.4.3	Ch 9, Sec 17, [4.1.3]	17.13.4.2	Ch 9, Sec 17, [13.4.2]	17.18.13	Ch 9, Sec 17, [18.1.13]
17.5.1	Ch 9, Sec 17, [5.1.1]	17.13.4.3	Ch 9, Sec 17, [13.4.3]	17.18.14	Ch 9, Sec 17, [18.1.14]
17.5.2	Ch 9, Sec 17, [5.1.2]	17.13.4.4	Ch 9, Sec 17, [13.4.4]	17.18.15	Ch 9, Sec 17, [18.1.15]
17.5.3	Ch 9, Sec 17, [5.1.3]	17.13.5	Ch 9, Sec 17, [13.5.1]	17.18.16	Ch 9, Sec 17, [18.1.16]
17.5.4	Ch 9, Sec 17, [5.1.4]	17.13.6.1	Ch 9, Sec 17, [13.6.1]	17.18.17	Ch 9, Sec 17, [18.1.17]
17.5.5	Ch 9, Sec 17, [5.1.5]	17.13.6.2	Ch 9, Sec 17, [13.6.3]	17.18.18	Ch 9, Sec 17, [18.1.18]
17.5.6	Ch 9, Sec 17, [5.1.6]	17.14.1	Ch 9, Sec 17, [14.1.1]	17.18.19	Ch 9, Sec 17, [18.1.19]
17.5.7	Ch 9, Sec 17, [5.1.7]	17.14.2	Ch 9, Sec 17, [14.1.2]	17.18.20	Ch 9, Sec 17, [18.1.20]
17.6	Ch 9, Sec 17, [6.1.1]	17.14.3	Ch 9, Sec 17, [14.1.3]	17.18.21	Ch 9, Sec 17, [18.1.21]
17.7	Ch 9, Sec 17, [7.1.1]	17.14.4	Ch 9, Sec 17, [14.1.4]	17.18.22	Ch 9, Sec 17, [18.1.22]
17.8	Ch 9, Sec 17, [8.1.1]	17.14.5	Ch 9, Sec 17, [14.1.5]	17.18.23	Ch 9, Sec 17, [18.1.23]
17.9	Ch 9, Sec 17, [9.1.1]	17.14.6	Ch 9, Sec 17, [14.1.6]	17.18.24	Ch 9, Sec 17, [18.1.24]
17.10	Ch 9, Sec 17, [10.1.1]	17.14.7	Ch 9, Sec 17, [14.1.7]	17.18.25	Ch 9, Sec 17, [18.1.25]
17.11.1	Ch 9, Sec 17, [11.1.2]	17.14.8	Ch 9, Sec 17, [14.1.8]	17.18.26	Ch 9, Sec 17, [18.1.26]
17.11.2	Ch 9, Sec 17, [11.1.2]	17.14.9	Ch 9, Sec 17, [14.1.9]	17.18.27	Ch 9, Sec 17, [18.1.27]
17.11.3	Ch 9, Sec 17, [11.1.3]	17.14.10	Ch 9, Sec 17, [14.1.10]	17.18.28	Ch 9, Sec 17, [18.1.28]
17.12.1	Ch 9, Sec 17, [12.1.1]	17.14.11	Ch 9, Sec 17, [14.1.11]	17.18.29	Ch 9, Sec 17, [18.1.29]
17.12.2	Ch 9, Sec 17, [12.1.2]	17.15	Ch 9, Sec 17, [15.1.1]	17.18.30	Ch 9, Sec 17, [18.1.30]
17.12.3	Ch 9, Sec 17, [12.1.3]	17.16.1	Ch 9, Sec 17, [16.1.1]	17.18.31	Ch 9, Sec 17, [18.1.31]
17.12.4	Ch 9, Sec 17, [12.1.4]	17.16.2	Ch 9, Sec 17, [16.1.2]	17.19	Ch 9, Sec 17, [19.1.1]
17.12.5	Ch 9, Sec 17, [12.1.5]	17.16.3	Ch 9, Sec 17, [16.1.3]	17.20.1	Ch 9, Sec 17, [20.1.1]
17.12.6	Ch 9, Sec 17, [12.1.6]	17.16.4	Ch 9, Sec 17, [16.1.4]	17.20.2	Ch 9, Sec 17, [20.1.2]
17.12.7	Ch 9, Sec 17, [12.1.7]	17.16.5	Ch 9, Sec 17, [16.1.5]	17.20.3	Ch 9, Sec 17, [20.1.3]
17.12.8	Ch 9, Sec 17, [12.1.8]	17.17	Ch 9, Sec 17, [17.1.1]	17.21.1	Ch 9, Sec 17, [21.1.2]
17.13.1.1	Ch 9, Sec 17, [13.1.1]	17.18.1	Ch 9, Sec 17, [18.1.1]	17.21.2	Ch 9, Sec 17, [21.1.3]
17.13.1.2	Ch 9, Sec 17, [13.1.2]	17.18.2	Ch 9, Sec 17, [18.1.2]	17.21.3	Ch 9, Sec 17, [21.1.4]
17.13.1.3	Ch 9, Sec 17, [13.1.3]	17.18.3	Ch 9, Sec 17, [18.1.3]	17.21.4	Ch 9, Sec 17, [21.1.5]
17.13.1.4	Ch 9, Sec 17, [13.1.4]	17.18.4	Ch 9, Sec 17, [18.1.4]	17.21.5	Ch 9, Sec 17, [21.1.6]
17.13.1.5	Ch 9, Sec 17, [13.1.5]	17.18.5	Ch 9, Sec 17, [18.1.5]	17.21.6	Ch 9, Sec 17, [21.1.7]
17.13.1.6	Ch 9, Sec 17, [13.1.6]	17.18.6	Ch 9, Sec 17, [18.1.6]	17.22.1	Ch 9, Sec 17, [22.1.2]

Table 18 : Equivalences between Part D, Chapter 9 and Chapter 18 of the IGC Code

Ref. in IGC Code, Chapter 18	Ref. in Part D, Chapter 9	Ref. in IGC Code, Chapter 18	Ref. in Part D, Chapter 9	Ref. in IGC Code, Chapter 18	Ref. in Part D, Chapter 9
18.1	–	18.10.1.2	Ch 9, Sec 18, [3.1.2]	18.10.3.1	Ch 9, Sec 18, [3.3.1]
18.2	Ch 9, Sec 18, [2]	18.10.1.3	Ch 9, Sec 18, [3.1.3]	18.10.3.2	Ch 9, Sec 18, [3.3.2]
18.3	–	18.10.1.4	Ch 9, Sec 18, [3.1.4]	18.10.3.3	Ch 9, Sec 18, [3.3.3]
18.4	–	18.10.1.5	Ch 9, Sec 18, [3.1.5]	18.10.3.4	Ch 9, Sec 18, [3.3.4]
18.5	–	18.10.2.1.1	Ch 9, Sec 18, [3.2.1], a)	18.10.4.1	Ch 9, Sec 18, [3.4.1]
18.6	–	18.10.2.1.2	Ch 9, Sec 18, [3.2.1], b)	18.10.4.2	Ch 9, Sec 18, [3.4.2]
18.7	–	18.10.2.1.3	Ch 9, Sec 18, [3.2.1], c)	18.10.5	Ch 9, Sec 18, [3.5.1]
18.8	–	18.10.2.1.4	Ch 9, Sec 18, [3.2.1], d)	18.11	–
18.9	–	18.10.2.2	Ch 9, Sec 18, [3.2.2]	18.12	–
18.10.1.1	Ch 9, Sec 18, [3.1.1]	18.10.2.3	Ch 9, Sec 18, [3.2.3]		

Part D

Service Notations

CHAPTER 10

TANKERS

- Section 1 General
- Section 2 Hull and Stability
- Section 3 Machinery and Cargo Systems

Section 1 General

1 General

1.1 Application

1.1.1 Ships complying with the requirements of this Chapter are eligible for the assignment of the service notation **tanker**, as defined in Pt A, Ch 1, Sec 2, [4.4.7].

1.1.2 Ships dealt with in this Chapter are to comply with:

- Part A of the Rules
- NR216 Materials and Welding
- applicable requirements according to Tab 1.

1.1.3 The liquid cargoes which are allowed to be carried by ships having the service notation **tanker** are specified in Ch 7, App 4.

Table 1 : Applicable requirements

Item		Greater than or equal to 500 GT	Less than 500 GT
Ship arrangement	L ≥ 65 m	<ul style="list-style-type: none"> • Part B • Ch 10, Sec 2 	<ul style="list-style-type: none"> • NR566 • Ch 10, Sec 2
	L < 65 m	<ul style="list-style-type: none"> • NR600 	<ul style="list-style-type: none"> • NR566 • Ch 10, Sec 2
Hull	L ≥ 65 m	<ul style="list-style-type: none"> • Part B • Ch 10, Sec 2 	<ul style="list-style-type: none"> • Part B • Ch 10, Sec 2
	L < 65 m	<ul style="list-style-type: none"> • NR600 	<ul style="list-style-type: none"> • NR600
Stability		<ul style="list-style-type: none"> • Part B • Ch 10, Sec 2 	<ul style="list-style-type: none"> • NR566 • Ch 10, Sec 2
Machinery and cargo systems		<ul style="list-style-type: none"> • Part C • Ch 10, Sec 3 	<ul style="list-style-type: none"> • NR566 • Ch 10, Sec 3
Electrical installations		<ul style="list-style-type: none"> • Part C 	<ul style="list-style-type: none"> • NR566
Automation		<ul style="list-style-type: none"> • Part C 	<ul style="list-style-type: none"> • NR566
Fire protection, detection and extinction		<ul style="list-style-type: none"> • Part C 	<ul style="list-style-type: none"> • NR566
<p>Note 1: NR566: Hull Arrangement, Stability and Systems for Ships less than 500 GT. NR600: Hull Structure and Arrangement for the Classification of Cargo Ships less than 65 m and Non Cargo Ships less than 90 m.</p>			

Section 2 Hull and Stability

1 General

1.1 Documents to be submitted

1.1.1 In addition to the documentation requested in Part B, the following information are to be submitted:

- indication of the type of cargoes, including cargo temperatures and densities.

2 General arrangement

2.1 Compartment arrangement

2.1.1 General

Tankers may be built with independent or integral cargo tanks.

2.1.2 Integral tanks

Cofferdams are to be fitted between cargo tanks and compartments intended for liquids likely to alter edible liquids carried.

Tanks are to be separated from any compartment containing heat sources by cofferdams or duly heat-insulated bulkheads.

2.1.3 Arrangement of tanks

In general, each tank is to be fitted with:

- a graduated metal gauge rod or any other equivalent sounding device
- an inspection door of adequate size fitted with a watertight metal cover secured by wing bolts or any other device offering equivalent safety
- an expansion system intended to avoid any excessive pressure and any risk of overflow due to a rise in temperature or occasional fermentation; the expansion capacity is to be about 0,5% of the tank cubic capacity
- a drain well that may be suppressed where precautions are taken to improve the running of liquids towards the suction pipes.

3 Stability

3.1 Intact stability

3.1.1 General

The stability of the ship for the loading conditions in Pt B, Ch 3, App 2, [1.2.3] is to be in compliance with the requirements in Pt B, Ch 3, Sec 2.

In general, a representative sample of loading conditions intended to be used for the ship is also to be submitted. The additional loading conditions are also to be in compliance with the requirements of Pt B, Ch 3, Sec 2.

4 Design loads

4.1 Loading conditions for longitudinal strength assessment

4.1.1 In addition to the requirements in Pt B, Ch 5, Sec 8, still water loads are to be calculated for the following loading conditions:

- partial loading conditions
- light and heavy ballast conditions
- mid-voyage conditions relating to tank cleaning or other operations where, at the Society's discretion, these differ significantly from the ballast conditions.

4.2 Load combinations for direct strength analysis

4.2.1 Applicable general load combinations

The load combinations defined in Ch 7, Sec 3, [4.3] are to be considered.

5 Hull scantlings

5.1 Strength check with respect to stresses due to the temperature gradient

5.1.1 Direct calculations of stresses induced in the hull structures by the temperature gradient are to be performed for ships intended to carry cargoes at temperatures exceeding 90°C. In these calculations, the water temperature is to be assumed equal to 0°C.

The calculations are to be submitted to the Society for review.

5.1.2 The stresses induced in the hull structures by the temperature gradient are to comply with the checking criteria in Part B, Chapter 7.

6 Scantlings of independent tank structures

6.1 General

6.1.1 Ships designed with independent cargo tanks are to comply with the applicable provisions of Part D, Chapter 7.

7 Supports of independent tanks

7.1 General

7.1.1 Ships designed with independent cargo tanks are to comply with the applicable provisions of Part D, Chapter 7.

8 Other structures

8.1 Machinery space

8.1.1 Extension of the hull structures within the machinery space

Longitudinal bulkheads carried through cofferdams are to be extended within the machinery space and be used preferably as longitudinal bulkheads for liquid cargo tanks. In any case, such extension is to be compatible with the shape of the structures of the double bottom, deck and platforms of the machinery space.

9 Construction and testing

9.1 Special structural details

9.1.1 The specific requirements in Pt B, Ch 13, Sec 5, [2] for ships with the service notation **tanker** are to be complied with.

Section 3 Machinery and Cargo Systems

1 General

1.1 Documents to be submitted

1.1.1 The documents listed in Tab 1 are to be submitted for approval.

2 Piping systems

2.1 General

2.1.1 Materials

- a) Materials used for piping systems are to comply with the provisions of Pt C, Ch 1, Sec 10, [2.1].
- b) Attention is drawn to any national standards or regulations which might restrict the use of materials in contact with edible substances.

2.1.2 Independence of piping systems

- a) The cargo piping system is to be entirely separated from other piping systems serving the ship.
- b) In the case of carriage of edible substances, arrangements are to be made to avoid any inadvertent contamination of the cargo. In particular, the filling and discharge connections serving the cargo tanks are to be located remote from those serving the machinery piping systems.

2.1.3 Passage of pipes through tanks

Cargo tanks containing edible substances are not to be passed through by pipes conveying other liquids.

2.2 Cargo piping and pumping

2.2.1 Cargo pumps

At least two cargo pumps are to be provided for transferring the cargo.

2.2.2 Level gauging systems

Level gauging systems of tanks containing edible substances are to be so designed as to avoid any contamination of the cargo.

2.3 Air pipes

2.3.1

- a) Air pipes of cargo tanks are to be fitted with automatic closing appliances. Refer to Pt C, Ch 1, Sec 10, [9.1].
- b) Air pipes of tanks containing edible substances are to be led as far as practicable from:
 - air pipes of sewage or flammable oil tanks
 - machinery ventilation outlets.

2.4 Refrigerating installations

2.4.1

- a) Where the cargo needs to be kept refrigerated for conservation purposes, the refrigerating installation is to comply with the applicable provisions of Part F, Chapter 7.
- b) Provisions are to be made to avoid any contamination of the cargo by the refrigeration fluid.

2.5 Cargo tank cleaning systems

2.5.1 Adequate means are to be provided for cleaning the cargo tanks.

2.6 Additional requirements for ships carrying category Z substances

2.6.1 Tankers carrying category Z substances are to comply with the provisions of Ch 7, Sec 4, [9.2.2].

Table 1 : Documents to be submitted

No.	Description of the document (1)
1	Diagram of the cargo piping system
2	Diagram of the cargo tank venting system
3	Diagram of the cargo tank level gauging system
4	Diagram of the cargo tank cleaning system
5	Diagram of the bilge and ballast systems serving the cargo spaces
6	Diagram of the cargo heating and refrigerating systems
(1) Diagrams are also to include, where applicable: <ul style="list-style-type: none">• the (local and remote) control and monitoring systems and automation systems• the instructions for the operation and maintenance of the piping system concerned (for information).	

Part D

Service Notations

CHAPTER 11

PASSENGER SHIPS

Section 1	General
Section 2	Ship Arrangement
Section 3	Hull and Stability
Section 4	Machinery and Cargo System
Section 5	Electrical Installations
Appendix 1	Calculation Method for Cross-Flooding Arrangements

Section 1 General

1 General

1.1 Application

1.1.1 Ships complying with the requirements of this Chapter are eligible for the assignment of the service notation **passenger ship**, as defined in Pt A, Ch 1, Sec 2, [4.5.2].

1.1.2 Ships dealt with in this Chapter are to comply with:

- Part A of the Rules
- NR216 Materials and Welding
- applicable requirements according to Tab 1.

1.1.3 For ships having to comply with the provisions of SOLAS Ch II-1 reg 8-1 and SOLAS Ch II-2 reg 21 and 22, the service notation **passenger ship** is to be completed by the additional service feature **SRTP** according to requirements of NR598 Implementation of Safe Return to Port and Orderly Evacuation.

1.1.4 Additional guidance for arrangement and structural assessment is provided in NI 640 Structural Assessment of Passenger Ships.

Table 1 : Applicable requirements

Item		Ships having the navigation notation unrestricted navigation	Ships having a navigation notation other than unrestricted navigation	
			Greater than or equal to 500 GT	Less than 500 GT
Ship arrangement	L ≥ 90 m	<ul style="list-style-type: none"> • Part B • Ch 11, Sec 2 	<ul style="list-style-type: none"> • Part B • Ch 11, Sec 2 	<ul style="list-style-type: none"> • NR566
	L < 90 m	<ul style="list-style-type: none"> • NR600 	<ul style="list-style-type: none"> • NR600 	<ul style="list-style-type: none"> • NR566
Hull	L ≥ 90 m	<ul style="list-style-type: none"> • Part B • Ch 11, Sec 3 	<ul style="list-style-type: none"> • Part B • Ch 11, Sec 3 	<ul style="list-style-type: none"> • Part B • Ch 11, Sec 3
	L < 90 m	<ul style="list-style-type: none"> • NR600 	<ul style="list-style-type: none"> • NR600 	<ul style="list-style-type: none"> • NR600
Stability		<ul style="list-style-type: none"> • Part B • Ch 11, Sec 3 	<ul style="list-style-type: none"> • Part B • Ch 11, Sec 3 	<ul style="list-style-type: none"> • NR566
Machinery and cargo systems		<ul style="list-style-type: none"> • Part C • Ch 11, Sec 4 	<ul style="list-style-type: none"> • Part C • Ch 11, Sec 4 	<ul style="list-style-type: none"> • NR566
Electrical installations		<ul style="list-style-type: none"> • Part C • Ch 11, Sec 5 	<ul style="list-style-type: none"> • Part C • Ch 11, Sec 5 	<ul style="list-style-type: none"> • NR566
Automation		<ul style="list-style-type: none"> • Part C 	<ul style="list-style-type: none"> • Part C 	<ul style="list-style-type: none"> • NR566
Fire protection, detection and extinction		<ul style="list-style-type: none"> • Part C 	<ul style="list-style-type: none"> • Part C 	<ul style="list-style-type: none"> • NR566
<p>Note 1: NR566: Hull Arrangement, Stability and Systems for Ships less than 500 GT NR600: Hull Structure and Arrangement for the Classification of Cargo Ships less than 65 m and Non Cargo Ships less than 90 m.</p>				

Section 2 Ship Arrangement

1 General

1.1 Definitions

1.1.1 Deepest subdivision load line

Deepest subdivision load line is the waterline which corresponds to the summer load line of the ship.

1.1.2 Passenger spaces

Passenger spaces are those spaces which are provided for the accommodation and use of passengers, excluding baggage, store, provision and mail rooms.

In all cases volumes and areas are to be calculated to moulded lines.

2 General arrangement design

2.1 Openings in watertight bulkheads below the bulkhead deck

2.1.1 Openings in machinery spaces

Not more than one door apart from the doors to shaft tunnels may be fitted in each watertight bulkhead within spaces containing the main and auxiliary propulsion machinery including boilers serving the needs of propulsion. Where two or more shafts are fitted the tunnels are to be connected by an inter-communicating passage. Only one door is to be provided between the machinery space and the tunnel spaces where two shafts are fitted and only two doors where there are more than two shafts. All these doors are to be of the sliding type and are to be so located as to have their sills as high as practicable. The hand gear for operating these doors from above the bulkhead deck is to be situated outside the spaces containing the machinery.

Portable plates on bulkheads are not permitted except in machinery spaces. Such plates are always to be in place before the voyage commences, and are not to be removed during navigation except in the case of urgent necessity at the discretion of the Master. The necessary precautions are to be taken in replacing them to ensure that the joints are watertight. The Society may permit not more than one power-operated sliding watertight door in each watertight bulkhead larger than 1,20 m to be substituted for these portable plates, provided these doors are intended to remain closed during navigation except in the case of urgent necessity at the discretion of the Master. These doors need not meet the requirements of complete closure by hand-operated gear in 90 seconds (see [2.3.3] e).

2.1.2 Openings in cargo spaces

Watertight doors complying with the requirements of [2.3.1] may be fitted in watertight bulkheads dividing cargo between deck spaces. Such doors may be hinged, rolling or sliding doors but are not to be remotely controlled. They are to be fitted at the highest level and as far from the shell plating as practicable, but in no case are the outboard vertical edges to be situated at a distance from the shell plating which is less than one fifth of the breadth of the ship, such distance being measured at right angles to the centreline at the level of the deepest subdivision load line.

The doors accessible during the voyage are to be fitted with a device which prevents unauthorised opening. When it is proposed to fit such doors, the number and arrangements are to receive the special consideration of the Society.

2.1.3 Openings in passenger ships carrying goods vehicles and accompanying personnel

This requirement applies to passenger ships designed or adapted for the carriage of goods vehicles and accompanying personnel where the total number of persons on board, other than passengers as defined in Pt A, Ch 1, Sec 2, [4.5.2], exceeds 12.

If in such a ship the total number of passengers which include personnel accompanying vehicles does not exceed:

$$N = 12 + \frac{A}{25}$$

where:

N : Maximum number of passengers for which the ship is certified

A : Total deck area, in m², of spaces available for the stowage of goods vehicles,

and where the clear height at the stowage position and at the entrance to such spaces is not less than 4 m, the provisions of [2.1.2] in respect of watertight doors apply except that the doors may be fitted at any level in watertight bulkheads dividing cargo spaces.

Additionally, indicators are required on the navigating bridge to show automatically when each door is closed and all door fastenings are secured.

2.1.4 Trunks and tunnels

Where trunkways or tunnels for access from crew accommodation to the stokehold, for piping, or for any other purpose are carried through watertight bulkheads, they are to be watertight and in accordance with the requirements of Pt B, Ch 4, Sec 5,

[10.5]. The access to at least one end of each such tunnel or trunkway, if used as a passage at sea, is to be through a trunk extending watertight to a height sufficient to permit access above the bulkhead deck. The access to the other end of the trunkway or tunnel may be through a watertight door of the type required by its location in the ship. Such trunkways or tunnels are not to extend through the first subdivision bulkhead abaft the collision bulkhead.

Where trunkways in connection with refrigerated cargo and ventilation or forced draught trunks are carried through more than one watertight bulkhead, the means of closure at such openings are to be operated by power and be capable of being closed from a central position situated above the bulkhead deck.

Where a ventilation trunk passing through a structure penetrates a watertight area of the bulkhead deck, the trunk is to be capable of withstanding the water pressure that may be present within the trunk, after having taken into account the maximum heel angle during flooding, in accordance with Ch 12, Sec 3, [2.3.5].

2.1.5 Additional requirements

In addition to [2.1.1], [2.1.2], [2.1.3], and [2.1.4], the requirements reported in [2.3.3] are to be complied with.

2.2 Openings in bulkheads above the bulkhead deck

2.2.1 General

Measures such as the fitting of partial bulkheads or webs are to be taken to limit the entry and spread of water above the bulkhead deck. When partial watertight bulkheads and webs are fitted on the bulkhead deck, above or in the immediate vicinity of watertight bulkheads, their connections with the shell and bulkhead deck are to be watertight so as to restrict the flow of water along the deck when the ship is in a heeled damaged condition. Where the partial watertight bulkhead does not line up with the bulkhead below, the bulkhead deck between is to be made effectively watertight. Where openings, pipes, scuppers, electric cables etc. are carried through the partial watertight bulkheads or decks within the immersed part of the bulkhead deck, arrangements are to be made to ensure the watertight integrity of the structure above the bulkhead deck.

The coamings of all openings in the exposed weather deck are to be of ample height and strength and are to be provided with efficient means for expeditiously closing them weathertight. Freeing ports, open rails and scuppers are to be fitted as necessary for rapidly cleaning the weather deck of water under all weather conditions.

Sidescuttles, gangway, cargo and fuelling ports and other means for closing openings in the shell plating above the bulkhead deck are to be of efficient design and construction and of sufficient strength (see Pt B, Ch 11, Sec 12) having regard to the spaces in which they are fitted and their positions relative to the deepest subdivision load line.

Efficient inside deadlights, so arranged that they can be easily and effectively closed and secured watertight, are to be provided for all sidescuttles to spaces below the first deck above the bulkhead deck.

2.2.2 Open end of air pipes

Air pipes terminating within a superstructure which are not fitted with watertight means of closure are to be considered as unprotected openings when applying Pt B, Ch 3, App 3, [1.6.11].

2.2.3 Additional requirements

In addition to [2.2.1] and [2.2.2], the requirements reported in [2.3.4] are to be complied with.

2.3 Doors

2.3.1 Requirements for doors

The requirements relevant to the operating systems for doors complying with the prescriptions in [2.3.2] and [2.3.3] are specified in Tab 1 for doors of internal watertight bulkheads and Tab 2 for doors of external watertight boundaries below equilibrium or intermediate waterplane.

2.3.2 Construction of watertight doors

The design, materials and construction of all watertight doors are to be to the satisfaction of the Society.

Such doors are to be suitably marked to ensure that they may be properly used to provide maximum safety.

The frames of vertical watertight doors are to have no groove at the bottom in which dirt might lodge and prevent the door closing properly.

2.3.3 Doors in watertight bulkheads below the bulkhead deck

- a) Watertight doors, except as provided in [2.1.2] paragraph 1 and [2.1.3], are to be capable of being closed simultaneously from the central operating console at the navigation bridge in not more than 60 s with the ship in the upright position.
- b) The means of operation whether by power or by hand of any power-operated sliding watertight door are to be capable of closing the door with the ship listed to 15° either way. Consideration is to also be given to the forces which may act on either side of the door as may be experienced when water is flowing through the opening applying a static head equivalent to a water height of at least 1 m above the sill on the centreline of the door.
- c) Watertight door controls, including hydraulic piping and electrical cables, are to be kept as close as practicable to the bulkhead in which the doors are fitted, in order to minimise the likelihood of them being involved in any damage which the ship may sustain. The positioning of watertight doors and their controls are to be such that if the ship sustains damage within

one fifth of the breadth of the ship, such distance being measured at right angles to the centreline at the level of the deepest subdivision load line, the operation of the watertight doors clear of the damaged portion of the ship is not impaired.

- d) All power-operated sliding watertight doors are to be provided with means of indication which show at all remote operating positions whether the doors are open or closed. Remote operating positions are only to be located at the navigating bridge and at the location where hand operation above the bulkhead deck is required by e).
- e) Each power-operated sliding watertight door:
- is to move vertically or horizontally;
 - is to be normally limited to a maximum clear opening width of 1,20 m. The Society may permit larger doors only to the extent considered necessary for the effective operation of the ship provided that other safety measures, including the following, are taken into consideration:
 - special consideration is to be given to the strength of the door and its closing appliances in order to prevent leakages;
 - the door is to be located outside the damage zone B/5.
 - is to be fitted with the necessary equipment to open and close the door using electrical power, hydraulic power, or any other form of power that is acceptable to the Society;
 - is to be provided with an individual hand-operated mechanism. It is to be possible to open and close the door by hand at the door itself from either side and, in addition, close the door from an accessible position above the bulkhead deck with an all round crank motion or some other movement providing the same degree of safety acceptable to the Society. Direction of rotation or other movement is to be clearly indicated at all operating positions. The time necessary for the complete closure of the door, when operating by hand gear, may not exceed 90 s with the ship in the upright position;
 - is to be provided with controls for opening and closing the door by power from both sides of the door and also for closing the door by power from the central operating console at the navigation bridge;
 - is to be provided with an audible alarm, distinct from any other alarm in the area, which is to sound whenever the door is closed remotely by power and which is to sound for at least 5 s but no more than 10 s before the door begins to move and is to continue sounding until the door is completely closed. In the case of remote hand operation it is sufficient for the audible alarm to sound only when the door is moving. Additionally, in passenger areas and areas of high ambient noise, the Society may require the audible alarm to be supplemented by an intermittent visual signal at the door;
 - is to have an approximately uniform rate of closure under power. The closure time, from the time the door begins to move to the time it reaches the completely closed position, is to in no case be less than 20 s or more than 40 s with the ship in the upright position.
- f) The electrical power required for power-operated sliding watertight doors is to be supplied from the emergency switchboard either directly or by a dedicated distribution board situated above the bulkhead deck. The associated control, indication and alarm circuits are to be supplied from the emergency switchboard either directly or by a dedicated distribution board situated above the bulkhead deck and be capable of being automatically supplied by a transitional source of emergency electrical power in the event of failure of either the main or emergency source of electrical power.

The transitional source of emergency electrical power is to consist of an accumulator battery suitably located for use in an emergency which is to operate without recharging while maintaining the voltage of the battery throughout the discharge period within 12% above or below its nominal voltage and be of sufficient capacity and so arranged as to supply power automatically, in the event of failure of either the main or emergency source of electrical power, to control, indication and alarm circuits at least for half an hour.

- g) Power-operated sliding watertight doors are to have either:
- a centralised hydraulic system with two independent power sources each consisting of a motor and pump capable of simultaneously closing all doors. In addition, there are to be for the whole installation hydraulic accumulators of sufficient capacity to operate all the doors at least three times, i.e. closed-open-closed, against an adverse list of 15°. This operating cycle is to be capable of being carried out when the accumulator is at the pump cut-in pressure. The fluid used is to be chosen considering the temperatures liable to be encountered by the installation during its service. The power operating system is to be designed to minimise the possibility of having a single failure in the hydraulic piping adversely affect the operation of more than one door. The hydraulic system is to be provided with a low-level alarm for hydraulic fluid reservoirs serving the power-operated system and a low gas pressure group alarm or other effective means of monitoring loss of stored energy in hydraulic accumulators. These alarms are to be audible and visual and are to be situated on the central operating console at the navigating bridge; or
 - an independent hydraulic system for each door with each power source consisting of a motor or pump capable of opening and closing the door. In addition, there is to be a hydraulic accumulator of sufficient capacity to operate the door at least three times, i.e. closed-open-closed, against an adverse list of 15°. This operating cycle is to be capable of being carried out when the accumulator is at the pump cut-in pressure. The fluid used is to be chosen considering the temperatures liable to be encountered by the installation during its service. A low gas pressure group alarm or other effective means of monitoring loss of stored energy in hydraulic accumulators is to be provided at the central operating console on the navigation bridge. Loss of stored energy indication at each local operating position is to also be provided; or
 - an independent electrical system and motor for each door with each power source consisting of a motor capable of opening and closing the door. The power source is to be capable of being automatically supplied by the transitional

source of emergency electrical power in the event of failure of either the main or emergency source of electrical power and with sufficient capacity to operate the door at least three times, i.e. closed-open-closed, against an adverse list of 15°.

The transitional source of emergency electrical power is to consist of an accumulator battery suitably located for use in an emergency which is to operate without recharging while maintaining the voltage of the battery throughout the discharge period within 12% above or below its nominal voltage and be of sufficient capacity and so arranged as to supply power automatically, in the event of failure of either the main or emergency source of electrical power, to watertight doors, but not necessarily all of them simultaneously, unless an independent source of stored energy is provided.

For the systems specified above, provision is to be made as follows:

Power systems for power-operated watertight sliding doors are to be separate from any other power system. A single failure in the electrical or hydraulic power-operated systems excluding the hydraulic actuator is not to prevent the hand operation of any door.

- h) Control handles are to be provided at each side of the bulkhead at a minimum height of 1,6 m above the floor and are to be so arranged as to enable persons passing through the doorway to hold both handles in the open position without being able to set the power closing mechanism in operation accidentally. The direction of movement of the handles in opening and closing the door is to be in the direction of door movement and is to be clearly indicated.
 - i) As far as practicable, electrical equipment and components for watertight doors are to be situated above the bulkhead deck and outside hazardous areas and spaces.
 - j) The enclosures of electrical components necessarily situated below the bulkhead deck are to provide suitable protection against the ingress of water.
 - k) Electric power, control, indication and alarm circuits are to be protected against faults in such a way that a failure in one door circuit is not to cause a failure in any other door circuit. Short-circuits or other faults in the alarm or indicator circuits of a door are not to result in a loss of power operation of that door. Arrangements are to be such that leakage of water into the electrical equipment located below the bulkhead deck is not to cause the door to open.
 - l) A single electrical failure in the power operating or control system of a power-operated sliding watertight door is not to result in a closed door opening. Availability of the power supply is to be continuously monitored at a point in the electric circuit as near as practicable to each of the motors required in g). Loss of any such power supply is to activate an audible and visual alarm at the central operating console at the navigation bridge.
 - m) Failure of the normal power supply of the required alarms are to be indicated by an audible and visual alarm at the central operating console at the navigation bridge.
 - n) The central operating console at the navigation bridge is to have a “master mode” switch with two modes of control:
 - a “local control” mode which is to allow any door to be locally opened and locally closed after use without automatic closure, and
 - a “doors closed” mode which is to automatically close any door that is open. The “doors closed” mode is to permit doors to be opened locally and is to automatically reclose the doors upon release of the local control mechanism.
- The “master mode” switch is to normally be in the “local control” mode. The “doors closed” mode is to only be used in an emergency or for testing purposes. Special consideration is to be given to the reliability of the “master mode” switch.
- o) The central operating console at the navigation bridge is to be provided with a diagram showing the location of each door, with visual indicators to show whether each door is open or closed. A red light is to indicate a door is fully open and a green light is to indicate a door is fully closed. When the door is closed remotely the red light is to indicate the intermediate position by flashing. The indicating circuit is to be independent of the control circuit for each door.
 - p) It is not to be possible to remotely open any door from the central operating console.
 - q) All watertight doors are to be kept closed during navigation. Certain watertight doors may be permitted to remain open during navigation only if considered absolutely necessary; that is, being open is determined essential to the safe and effective operation of the ship's machinery or to permit passengers normally unrestricted access throughout the passenger area. Such determination is to be made by the Society only after careful consideration of the impact on ship operations and survivability. A watertight door permitted to remain thus open is to be clearly indicated in the ship's stability information and the damage control documentation and is always to be ready for immediate closure.
 - r) All watertight doors, including sliding doors, operated by hydraulic door actuators, either a central hydraulic unit or an independent hydraulic unit for each door is to be provided with a low fluid level alarm or low gas pressure alarm, as applicable or some other means of monitoring loss of stored energy in the hydraulic accumulators. This alarm is to be both audible and visible and is to be located on the central operating console at the navigation bridge.
 - s) Signboard/instructions are to be placed in way of the door advising how to act when the door closed.

2.3.4 Doors in bulkheads above the bulkhead deck

a) *General*

Doors are to be capable of being opened and closed by hand locally from both sides of the doors with the ship listed to 15° to either side.

Position indicators are to be provided on the bridge to show that the doors are open or closed and that the dogs are fully and properly engaged.

Where the doors also serve as fire doors they are to be provided with position indicators at the fire control station and audible alarms as required for fire doors, as well as for weathertight doors. Where two doors are fitted they must be capable of independent operation remotely and from both sides of each door.

b) *Doors normally closed at sea*

In addition to a), doors not required for frequent access while at sea are to be kept normally closed and may be of either hinged or sliding type.

Doors kept normally closed are to have local operation from both sides of the doors and are to be labelled on both sides: “to be kept closed at sea”.

c) *Doors normally open at sea*

Where fitted in public spaces for the passage of passengers and crew, the doors may be kept normally open at sea and may be either hinged or sliding type.

In addition to a), doors kept normally open at sea are to have local power operation from both sides of the door and remote closing from the bridge. Operation of these doors is to be similar to that specified in Pt C, Ch 4, Sec 5 where, using a “master mode” switch on the bridge, local control can override the remote closing feature after which the door is automatically remotely reclosed upon release of the local control mechanism.

Doors kept normally open at sea are to have audible alarms, distinct from any other alarm in the area, which sound whenever the doors are closed remotely. The alarms are to sound for at least 5 s but not more than 10 s before the doors begins to move and continue sounding until the doors are completely closed. In passenger areas and areas of high ambient noise, the audible alarms are to be supplemented by visual signals at both sides of the doors.

d) *Failure of the normal power supply of the required alarms are to be indicated by an audible and visual alarm.*

e) *All watertight doors, including sliding doors, operated by hydraulic door actuators, either a central hydraulic unit or an independent hydraulic unit for each door is to be provided with a low fluid level alarm or low gas pressure alarm, as applicable or some other means of monitoring loss of stored energy in the hydraulic accumulators. This alarm is to be both audible and visible and is to be located on the central operating console at the navigation bridge.*

f) *Signboard/instructions are to be placed in way of the door advising how to act when the door closed.*

Table 1 : Doors in internal watertight bulkheads of passenger ships

Position relative to bulkhead deck	Frequency of use while at sea	Type (1)	Remote closure	Remote indication	Audible or visual alarm	Notice
Below	Used (2)	POS	X	X	X (local)	
	Permanently closed (3) (4)	S, H				X
At or above	Used	POS, POH	X	X	X (local)	
	Used (5)	S, H		X		X
	Used (Doors giving access to below ro-ro deck)	S, H		X	X (remote)	X
	Permanently closed (3) (5)	S, H		X	X (remote)	X

- (1) POS : Power operated, sliding or rolling
POH : Power operated, hinged
S : Sliding or rolling
H : Hinged
- (2) See SOLAS II-1/22.3 and IMO MSC.1/Circ.1564
- (3) Doors are to be fitted with a device which prevents unauthorized opening.
- (4) Passenger ships which have to comply with [2.1.3] require an indicator on the navigation bridge to show automatically when each door is closed and all doors fastenings are secured.
- (5) If hinged, this door is to be of single action type.

Table 2 : Doors in external watertight boundaries below equilibrium or intermediate waterplane

Position relative to bulkhead deck	Frequency of use while at sea	Type (1)	Remote closure	Remote indication	Audible or visual alarm	Notice
Below	Permanently closed (2)	S, H				X
At or above	Normally closed (3)	S, H		X		X
	Normally closed (Doors giving access to below ro-ro deck)	S, H		X	X (remote)	X
	Permanently closed (2)	S, H		X	X (remote)	X
<p>(1) S : Sliding or rolling H : Hinged</p> <p>(2) Doors are to be fitted with a device which prevents unauthorized opening.</p> <p>(3) If hinged, this door is to be of single action type.</p>						

2.4 Ballast compartment arrangement

2.4.1 *Water ballast is not to be, in general, carried in tanks intended for fuel oil. In ships in which it is not practicable to avoid putting water in fuel oil tanks, oily-water separating equipment to the satisfaction of the Society is to be fitted, or other alternative means, such as discharge to shore facilities, acceptable to the Society is to be provided for disposing of the oily-water ballast (see Pt C, Ch 1, Sec 10, [7]).*

2.5 Machinery compartment arrangement

2.5.1 When longitudinal bulkheads are fitted in the machinery space, adequate self-operating arrangements are to be provided in order to avoid excessive heel after damage.

Where such arrangements are cross-flooding systems, their area is to be calculated in accordance with the requirements in Ch 11, App 1 In addition, such systems are to comply with the criteria for the maximum time necessary to cross flood according to Ch 11, Sec 3, [2.3.5], item a).

Section 3 Hull and Stability

1 General

1.1 Documents to be submitted

1.1.1 In addition to the documentation requested in Pt B, Ch 1, Sec 4, the following documents are to be submitted:

- Stability documentation as specified in Article [2]
- Plan of design loads on deck as specified in [4.1].

2 Stability

2.1 Definitions

2.1.1 Deepest subdivision draught

The deepest subdivision draught (d_s) is the waterline which corresponds to the summer load line draught of the ship.

2.1.2 Light service draught

Light service draught (d_l) is the service draught corresponding to the lightest anticipated loading and associated tankage, including, however, such ballast as may be necessary for stability and/or immersion.

2.1.3 Partial subdivision draught

The partial subdivision draught (d_p) is the light service draught plus 60% of the difference between the light service draught and the deepest subdivision draught.

2.1.4 Subdivision length L_s

The subdivision length L_s is the greatest projected moulded length of that part of the ship at or below deck or decks limiting the vertical extent of flooding with the ship at the deepest subdivision draught.

2.1.5 Machinery space

Machinery spaces are spaces between the watertight boundaries of a space containing the main and auxiliary propulsion machinery, including boilers, generators and electric motors primarily intended for propulsion. In the case of unusual arrangements, the Society may define the limits of the machinery spaces.

2.1.6 Other definitions

Mid-length is the mid point of the subdivision length of the ship.

Aft terminal is the aft limit of the subdivision length.

Forward terminal is the forward limit of the subdivision length.

Breadth B is the greatest moulded breadth, in m, of the ship at or below the deepest subdivision draught.

Draught d is the vertical distance, in m, from the moulded baseline at mid-length to the waterline in question.

Permeability μ of a space is the proportion of the immersed volume of that space which can be occupied by water.

2.2 Intact stability

2.2.1 General

Every passenger ship regardless of size is to be inclined upon its completion. The lightship displacement and the longitudinal, transverse and vertical position of its centre of gravity shall be determined. The Master is to be supplied with such information satisfactory to the Society as is necessary to enable him by rapid and simple processes to obtain accurate guidance as to the stability of the ship under varying conditions of service. A copy of the stability information is to be furnished to the Society.

Where any alterations are made to a ship so as to materially affect the stability information supplied to the Master, amended stability information is to be provided. If necessary the ship is to be re-inclined.

2.2.2 Periodical lightweight check

At periodical intervals not exceeding five years, a lightweight survey is to be carried out on all passenger ships to verify any changes in lightship displacement and longitudinal centre of gravity. The ship is to be re-inclined whenever, in comparison with the approved stability information, a deviation from the lightship displacement exceeding 2% or a deviation of the longitudinal centre of gravity exceeding 1% of L_{LL} is found, or anticipated.

2.2.3 Standard requirements

In addition to Pt B, Ch 3, Sec 2, [2], the requirements in [2.2.4] to [2.2.6] are to be complied with for the loading conditions defined in Pt B, Ch 3, App 2, [1.2.1] and Pt B, Ch 3, App 2, [1.2.9].

2.2.4 Crowding of passengers

The angle of heel on account of crowding of passengers to one side as defined below may not exceed 10°:

- a minimum weight of 75 kg is to be assumed for each passenger except that this value may be increased subject to the approval of the Society. In addition, the mass and distribution of the luggage is to be approved by the Society;
- the height of the centre of gravity for passengers is to be assumed equal to:
 - 1,0 m above deck level for passengers standing upright. Account may be taken, if necessary, of camber and sheer of deck; and
 - 0,3 m above the seat in respect of seated passengers.
- passengers and luggage are to be considered to be in the spaces normally at their disposal;
- passengers without luggage are to be considered as distributed to produce the most unfavourable combination of passenger heeling moment and/or initial metacentric height, which may be obtained in practice. In this connection, a value higher than four persons per square metre is not necessary.

2.2.5 Maximum turning angle

The angle of heel on account of turning may not exceed 10° when calculated using the following formula:

$$M_R = 0,02 \frac{V_0^2}{L_S} \Delta \left(KG - \frac{T_1}{2} \right)$$

where:

- M_R : Heeling moment, in t.m
- V_0 : Service speed, in m/s
- T_1 : Mean draught, in m
- KG : Height of centre of gravity above keel, in m.

2.2.6 Where anti-rolling devices are installed in a ship, the Society is to be satisfied that the above criteria can be maintained when the devices are in operation.

2.3 Damage stability for ships where SDS notation has been required

2.3.1 General

The requirements of this Section are to be applied to passenger ships in conjunction with the exploratory notes as set out by the IMO Resolution MSC 429(98).

2.3.2 Required subdivision index R

The required subdivision index R of a passenger ship according to the total number of persons on board is defined in Tab 1. These regulations are intended to provide ships with a minimum standard of subdivision. In addition to these requirements, the requirements of [2.3.12] are to be complied with.

Table 1 : Required subdivision index R

Total number of persons on board N	R
$N < 400$	0,722
$400 \leq N \leq 1350$	$N / 7580 + 0,66923$
$1350 < N \leq 6000$	$0,0369 \ln (N + 89,048) + 0,579$
$N > 6000$	$1 - (852,5 + 0,03875 N) / (N + 5000)$

2.3.3 Attained subdivision index A

The attained subdivision index A is to be calculated in accordance with Pt B, Ch 3, App 3, [1.4].

The attained subdivision index A is not to be less than the required subdivision index R. In addition, the partial indices A_s , A_p and A_L are not to be less than 0,9 R.

2.3.4 Calculation of the factor p_i

The factor p_i is to be calculated in accordance with Pt B, Ch 3, App 3, [1.5].

2.3.5 Calculation of the factor s_i

The factor s_i is to be determined for each case of assumed flooding, involving a compartment or group of compartments, in accordance with the following notations and the provisions in this regulation.

- θ_e : The equilibrium heel in any stage of flooding, in degrees

- θ_v : The angle, in any stage of flooding, where the righting lever becomes negative, or the angle at which an opening incapable of being closed weathertight becomes submerged
 In applying this criterion, openings which are incapable of being closed weathertight include ventilators that have to remain open to supply air to the engine room or emergency generator room for the effective operation of the ship.
- GZ_{max} : The maximum positive righting lever, in metres, up to the angle θ_v
- Range : The Range of positive righting levers, in degrees, measured from the angle θ_e . The positive range is to be taken up to the angle θ_v .

Flooding stage is any discrete step during the flooding process, including the stage before equalization (if any) until final equilibrium has been reached.

The factor s_p , for any damage case at any initial loading condition, d_p , shall be obtained from the formula:

$$s_i = \min[s_{intermediate,i}, (s_{final,i} \cdot s_{mom,i})]$$

where:

$s_{intermediate,i}$: The probability to survive all intermediate flooding stages until the final equilibrium stage, and is calculated in accordance with item a)

$s_{final,i}$: The probability to survive in the final equilibrium stage of flooding. It is calculated in accordance with item b)

$s_{mom,i}$: The probability to survive heeling moments, and is calculated in accordance with item c)

a) Calculation of $s_{intermediate}$:

The factor $s_{intermediate,i}$ is to be taken as the least of the s -factors obtained from all flooding stages including the stage before equalization, if any, and is to be calculated as follows:

$$s_{intermediate,i} = \left[\frac{GZ_{max}}{0,05} \cdot \frac{Range}{7} \right]^{\frac{1}{4}}$$

where GZ_{max} is not to be taken as more than 0,05 m and Range as not more than 7°.

$s_{intermediate,i} = 0$, if the intermediate heel angle exceeds 15°.

Where cross-flooding fittings are required, the time for equalization is not to exceed 10 min. The time for equalization is to be calculated in accordance with Ch 11, App 1

b) Calculation of s_{final} :

The factor $s_{final,i}$ is to be obtained from the formula:

$$s_{final,i} = K \left[\frac{GZ_{max}}{TGZ_{max}} \cdot \frac{Range}{TRange} \right]^{\frac{1}{4}}$$

where:

GZ_{max} is not to be taken as more than TGZ_{max}

Range is not to be taken as more than T_{Range}

TGZ_{max} is taken equal to:

- $TGZ_{max} = 0,20$ m for ro-ro passenger ships each damage case that involves a ro-ro space
- $TGZ_{max} = 0,12$ m otherwise

T_{Range} is taken equal to:

- $T_{Range} = 20^\circ$ for ro-ro passenger ships each damage case that involves a ro-ro space,
- $T_{Range} = 16^\circ$ otherwise

K is taken equal to:

- $K = 1$ if $\theta_e \leq \theta_{min}$
- $K = 0$ if $\theta_e \geq \theta_{max}$
- $K = \sqrt{\frac{\theta_{max} - \theta_e}{\theta_{max} - \theta_{min}}}$ otherwise

where:

θ_{min} is equal to 7°

θ_{max} is equal to 15°.

c) Calculation of s_{mom} :

The factor $s_{mom,i}$ is to be calculated at the final equilibrium from the formula:

$$s_{mom,i} = \frac{(GZ_{max} - 0,04) \text{ Displacement}}{M_{heel}}$$

where:

$$s_{mom,i} \leq 1$$

Displacement is the intact displacement at the respective draught (d_s, d_p, d_t)

M_{heel} is the maximum assumed heeling moment as calculated as follows:

$$M_{heel} = \max[M_{passengers}, M_{wind}, M_{survivalcraft}]$$

where heeling moments $M_{passenger}$, M_{wind} and $M_{survivalcraft}$ are calculated in [2.3.11].

2.3.6 Equalization arrangements

Unsymmetrical flooding is to be kept to a minimum consistent with the efficient arrangements. Where it is necessary to correct large angles of heel, the means adopted shall, where practicable, be self-acting, but in any case where controls to equalization devices are provided they are to be operable from above the bulkhead deck. These fittings together with their controls are to be acceptable to the Society. Suitable information concerning the use of equalization devices are to be supplied to the master of the ship.

Tanks and compartments taking part in such equalization are to be fitted with air pipes or equivalent means of sufficient cross-section to ensure that the flow of water into the equalization compartments is not delayed.

2.3.7 Cases where s_i is to be equal to zero

The factor s_i is to be taken as zero in those cases where the final waterline, taking into account sinkage, heel and trim, immerses:

- the lower edge of openings through which progressive flooding may take place and such flooding is not accounted for in the calculation of factor s_i . Such openings are to include air-pipes, ventilators and openings which are closed by means of weathertight doors or hatch covers, but the openings closed by means of watertight manhole covers and flush scuttles, small watertight hatch covers, remotely operated sliding watertight doors, side scuttles of the non-opening type as well as watertight access doors and hatch covers required to be kept closed at sea need not be considered.
- any part of the bulkhead deck considered a horizontal evacuation route.

The factor s_i is to be taken as zero if, taking into account sinkage, heel and trim, any of the following occur in any intermediate stage or in the final stage of flooding:

- immersion of any vertical escape hatch in the bulkhead deck intended for compliance with the applicable requirements of Pt C, Ch 4, Sec 8
- any controls intended for the operation of watertight doors, equalization devices, valves on piping or on ventilation ducts intended to maintain the integrity of watertight bulkheads from above the bulkhead deck become inaccessible or inoperable
- immersion of any part of piping or ventilation ducts located within the assumed extent of damage and carried through a watertight boundary if this can lead to the progressive flooding of compartment not assumed as flooded.

2.3.8 Calculation of the factor v_i

Where horizontal watertight boundaries are fitted above the waterline under consideration the s -value calculated for the lower compartment or group of compartments is to be obtained by multiplying the value as determined in [2.3.5] by the reduction factor v_m defined below, which represents the probability that the spaces above the horizontal subdivision will not be flooded.

The factor v_i is to be calculated in accordance with Pt B, Ch 3, App 3, [1.6.10] and Pt B, Ch 3, App 3, [1.6.11].

2.3.9 Contribution dA to the index A

The contribution dA to the index A is to be calculated in accordance with Pt B, Ch 3, App 3, [1.6.12].

2.3.10 Permeability

For the purpose of the subdivision and damage stability calculations of the regulations, the permeability of each general compartment or part of a compartment is to be according to Tab 2.

Other figures for permeability may be used if substantiated by calculations.

Table 2 : Values of permeability

Spaces	Permeability
Appropriated to stores	0,60
Occupied by accommodation or voids	0,95
Occupied by machinery	0,85
Intended for liquids	0 or 0,95 (1)
(1) whichever results in the more severe requirements.	

2.3.11 Inclining moments

The following inclining moments are to be taken into account:

a) *Moment due to the crowding of passengers:*

$M_{passenger}$ is the maximum assumed heeling moment resulting from movement of passengers, and is to be obtained as follows:

$$M_{passenger} = (0,075 N_p) (0,45 B) \text{ (tm)}$$

where:

- N_p : Maximum number of passengers permitted to be on board in the service condition corresponding to the deepest subdivision draught under consideration; and
- B : Breadth of the ship.

Alternatively, the heeling moment may be calculated assuming the passengers are distributed with 4 persons per square metre on available deck areas towards one side of the ship on the decks where muster stations are located and in such a way that they produce the most adverse heeling moment. In doing so, a weight of 75 kg per passenger is to be assumed.

b) Moment due to launching of all fully loaded davit-launched survival craft on one side:

$M_{\text{Survivalcraft}}$ is the maximum assumed heeling moment due to the launching of all fully loaded davit-launched survival craft on one side of the ship. It shall be calculated using the following assumptions:

- all lifeboats and rescue boats fitted on the side to which the ship has heeled after having sustained damage are to be assumed to be swung out fully loaded and ready for lowering.
- for lifeboats which are arranged to be launched fully loaded from the stowed position, the maximum heeling moment during launching is to be taken.
- a fully loaded davit-launched liferaft attached to each davit on the side to which the ship has heeled after having sustained damage is to be assumed to be swung out ready for lowering.
- persons not in the life-saving appliances which are swung out are not to provide either additional heeling or righting moment.
- life-saving appliances on the side of the ship opposite to the side to which the ship has heeled are to be assumed to be in a stowed position.

c) Moment due to wind pressure:

M_{wind} is the maximum assumed wind force acting in a damage situation:

$$M_{\text{wind}} = (P A Z) / 9,806 \cdot 10^3 \text{ (tm)}$$

- P : Wind pressure
 $P = 120 \text{ N/m}^2$

A : Projected lateral area above waterline

z : Distance from centre of lateral projected area above waterline to $T/2$; and

T : Ship's draught, d_1 .

2.3.12 Special requirements concerning stability

A passenger ship intended to carry 400 or more persons is to have watertight subdivision abaft the collision bulkhead so that $s_i = 1$ for a damage involving all the compartments with $0.08L$ measured from the forward perpendicular for the three loading conditions used to calculate the attained subdivision index A . If the attained subdivision index A is calculated for different trims, this requirement shall also be satisfied for those loading conditions.

A passenger ship intended to carry 36 or more persons is to be capable of withstanding damage along the side shell to an extent specified below. Compliance with this regulation is to be achieved by demonstrating that s_i , as defined in [2.3.5], is not less than 0,9 for the three loading conditions used to calculate the attained subdivision index A . If the attained subdivision index A is calculated for different trims, this requirement is also to be satisfied for those loading conditions.

The damage extent to be assumed when demonstrating compliance with the above paragraph, is to be dependent on the total number of persons carried, and L , such that:

- the vertical extent of damage is to extend from the ships moulded baseline to a position up to 12,5 m above the position of the deepest subdivision draught as defined in [2.1], unless a lesser vertical extent of damage were to give a lower value of s_i in which case this reduced extent is to be used.
- where 400 or more persons are to be carried, a damage length of $0,03 L$ but not less than 3 m is to be assumed at any position along the side shell, in conjunction with a penetration inboard of $0,1 B$ but not less than 0,75 m measured inboard from the ship side, at right angles to the centreline at the level of the deepest subdivision draught.
- where less than 400 persons are carried, damage length is to be assumed at any position along the shell side between transverse watertight bulkheads provided that the distance between two adjacent transverse watertight bulkheads is not less than the assumed damage length. If the distance between adjacent transverse watertight bulkheads is less than the assumed damage length, only one of these bulkheads is to be considered effective for the purpose of demonstrating compliance with the criteria $s_i \geq 0,9$.
- where 36 persons are carried, a damage length of $0,015 L$ but not less than 3 m is to be assumed, in conjunction with a penetration inboard of $0,05 B$ but not less than 0,75 m.
- where more than 36, but fewer than 400 persons are carried the values of damage length and penetration inboard, used in the determination of the assumed extent of damage, are to be obtained by linear interpolation between the values of damage length and penetration which apply for ships carrying 36 persons and 400 persons.

2.3.13 Documents to be supplied

The master is to be supplied with such information to the satisfaction of the Society as is necessary to enable him by rapid and simple processes to obtain accurate guidance as to the stability of the ship under varying conditions of service. A copy of the stability information shall be furnished to the Society.

The information should include:

- curves or tables of minimum operational metacentric height (GM) and maximum permissible trim versus draught which assures compliance with the intact and damage stability requirements where applicable, alternatively corresponding curves or tables of the maximum allowable vertical centre of gravity (KG) and maximum permissible trim versus draught, or with the equivalents of either of these curves or tables.
- instructions concerning the operation of cross-flooding arrangements
- all other data and aids which might be necessary to maintain the required intact stability and stability after damage.

The intact and damage stability information specified above are to be presented as consolidated data and encompass the full operating range of draught and trim. Applied trim values shall coincide in all stability information intended for use on board. Information not required for determination of stability and trim limits should be excluded from this information.

If the damage stability is calculated in accordance with the present sub-article, a stability limit curve is to be determined using linear interpolation between the minimum required GM assumed for each of the three draughts d_s , d_p and d_i . When additional subdivision indices are calculated for different trims, a single envelope curve based on the minimum values from this calculations is to be presented. When it is intended to develop curves of maximum permissible KG, it is to be ensured that the resulting maximum KG curves correspond with a linear variation of GM.

As an alternative to a single envelope curve, the calculations for additional trims may be carried out with one common GM for all of the trims assumed at each subdivision draught. The lowest values of each partial index A_s , A_p and A_i across these trims shall then be used in the summation of the attained subdivision index A according to [2.3.3]. This will result in one GM limit curve based on the GM used at each draught. A trim limit diagram showing the assumed trim range shall be developed.

When curves or tables of minimum operational metacentric height (GM) or maximum allowable KG versus draught are not provided, the master is to ensure that the operating condition does not deviate from approved loading conditions, or verify by calculation that the stability requirements are satisfied for this loading condition.

2.3.14 Damage control documentation

Plans showing clearly for each deck and hold the boundaries of the watertight compartments, the openings therein with the means of closure and position of any controls thereof, and the arrangements for the correction of any list due to flooding are to be permanently exhibited for the guidance of the officer in charge of the ship. In addition, booklets containing the aforementioned information are to be made available to the officers of the ship.

Detailed description of the information to be included in the damage control documentation is reported in Pt B, Ch 3, Sec 3, [4].

3 Structure design principles

3.1 Hull structure

3.1.1 Framing

In general, the strength deck and the bottom of passenger ships of more than 100 m in length are to be longitudinally framed. Where a transverse framing system is adopted for such ships, it is to be considered by the Society on a case-by-case basis.

4 Design loads

4.1 Loads on deck

4.1.1 Plan of design loads on deck

A plan of design static loads on deck, including fork lift areas, axle loads and tyre print areas of wheeled loads, is to be provided for information.

All values displayed on this plan are to be at least equivalent to the values given by the present Rules for each kind of load.

4.2 Sea pressures

4.2.1 Bow impact pressure

The bow impact pressure p_{Fi} , in kN/m², is to be taken as obtained in Pt B, Ch 5, Sec 5, [4.3.1] considering the coefficient C_z calculated from the following formulae:

- for $z \geq 21,5 H + T_{LC} - 11$:

$$C_z = [10,75H - 0,5(z - T_{LC})] \left[0,82 - 0,09 \left(\frac{z - T_{LC}}{T_{LC}} \right) \right]$$

- for $z < 21,5 H + T_{LC} - 11$:

$$C_z = \left[4,5 - 0,5 \left(\frac{z - T_{LC}}{T_{LC}} \right) \right]$$

where:

- H : Wave parameter defined in Pt B, Ch 5, Sec 3, for a reference length calculated with:
 $\alpha = 0,65 C_{W-LC}^{-1,3}$
 $f_{\alpha} = 1,0$
- z : z co-ordinate, in m, of the calculation point, with respect to the reference co-ordinate system defined in Pt B, Ch 1, Sec 3, [2.6]

Other values of bow impact pressure may be considered by the Society on a case-by-case basis, provided that they are documented through model tests or full scale measurements.

5 Hull girder strength

5.1 Basic criteria

5.1.1 Strength deck

In addition to the requirements in Pt B, Ch 6, Sec 1, [1.3], the contribution of the hull structures up to the strength deck to the longitudinal strength is to be assessed through a finite element analysis of the whole ship in the following cases:

- when the size of openings in the side shell and/or longitudinal bulkheads located below the deck assumed by the Designer as the strength deck decrease significantly the capability of the plating to transmit shear forces to the strength deck.
- when the ends of superstructures which are required to contribute to longitudinal strength may be considered not effectively connected to the hull structures in way.

5.2 Global transverse strength

5.2.1 The behaviour of the ship primary structural members under racking effects due to transverse forces induced by transverse accelerations is to be investigated according to Pt B, Ch 7, App 1, or by means of a complete ship model under transverse accelerations load case according to NI640.

6 Hull scantlings

6.1 Balcony doors

6.1.1 General

Glazed sliding doors fitted on sides of superstructures are to comply with the following requirements:

- Pt B, Ch 11, Sec 12, [3.3] for the assessment of glass panes
- [6.1.2] for the structural testing of supporting frames.

6.1.2 Supporting frame structural testing

Strength test of balcony doors supporting frames is to be carried out according to the following procedure:

- the structural testing is to be carried out at twice the design pressure defined in Pt B, Ch 5, Sec 5, [5]
- the door assembly, its supporting frame and supporting structure are to be same as, or deemed representative of the ship actual arrangement
- the pressure is to be applied uniformly on the door entire external area
- the glass panel may be alternatively replaced by a steel plate, of reduced thickness in order to represent equivalent flexural stiffness of the glass
- the pressure is to be maintained for not less than 5 minutes
- visual inspection is to be carried out after testing, without damage nor deformation.

Section 4 Machinery and Cargo System

1 Bilge system

1.1 General

1.1.1

- a) *The bilge pumping system required in Pt C, Ch 1, Sec 10, [6] shall be capable of operation under all practicable conditions after a casualty, whether the ship is upright or listed. For this purpose, wing suctions shall generally be fitted except in narrow compartments at the end of the ship where one suction may be sufficient. In compartments of unusual form, additional suctions may be required.*
- b) *Arrangements shall be made whereby water in the compartment may find its way to the suction pipes.*
- c) *Where, for particular compartments, the Society is satisfied that the provisions of drainage may be undesirable, it may allow such provision to be dispensed with if damage stability calculations carried out in accordance with Ch 11, Sec 3, [2] show that the survival capability of the ship will not be impaired.*

1.2 Bilge pumps

1.2.1 Number and capacity of bilge pumps

- a) a) *At least three power pumps shall be fitted connected to the bilge main, one of which may be driven by the propulsion machinery. Where the bilge pump numeral is 30 or more, one additional independent power pump shall be provided.*

The bilge pump numeral shall be calculated as follows:

- *when P_1 is greater than P :*

bilge pump numeral =

$$72 \left[\frac{M + 2P_1}{V + P_1 - P} \right]$$

- *in other cases:*

bilge pump numeral =

$$72 \left[\frac{M + 2P}{V} \right]$$

where:

L : Length of the ship (metres), as defined in Pt B, Ch 1, Sec 3, [2.1.1]

M : Volume of the machinery space (cubic metres), as defined in Ch 11, Sec 3, [2.1.5], that is below the bulkhead deck; with the addition thereto of the volume of any permanent oil fuel bunkers which may be situated above the inner bottom and forward of, or abaft, the machinery space

P : Whole volume of the passenger and crew spaces below the bulkhead deck (cubic metres), which are provided for the accommodation and use of passengers and crew, excluding baggage, store and provision rooms

V : Whole volume of the ship below the bulkhead deck (cubic metres).

$$P_1 = K \cdot N$$

where:

N : Number of passengers for which the ship is to be certified

$$K = 0,056 L$$

However, where the value of $K \cdot N$ is greater than the sum of P and the whole volume of the actual passenger spaces above the bulkhead deck, the figure to be taken as P_1 is that sum or two-thirds $K \cdot N$, whichever is the greater.

- b) *Each of the above pumps is to have a capacity not less than that required in Pt C, Ch 1, Sec 10, [6.7.4].*

- c) *For use of ejectors in lieu of bilge pumps, see Pt C, Ch 1, Sec 10, [6.7.2].*

1.2.2 Location of bilge pumps

Where practicable, the power bilge pumps shall be placed in separate watertight compartments and so arranged or situated that these compartments will not be flooded by the same damage. If the main propulsion machinery, auxiliary machinery and boilers are in two or more watertight compartments, the pumps available for bilge service shall be distributed as far as is possible throughout these compartments.

1.2.3 Availability of pumps

On a ship of 91,5 m in length and upwards or having a criterion numeral of 30 or more, as stated in Ch 11, Sec 3, [2.3.6], the arrangements shall be such that at least one power bilge pump will be available for use in all flooding conditions which the ship is required to withstand, and in all flooding conditions derived from consideration of minor damages as specified in Ch 11, Sec 3, [2.3.12], as follows:

- a) *one of the required bilge pumps shall be an emergency pump of a reliable submersible type having a source of power situated above the bulkhead deck, or*
- b) *the bilge pumps and their sources of power shall be so distributed throughout the length of the ship that at least one pump in an undamaged compartment will be available.*

1.2.4 Draining capability

With the exception of additional pumps which may be provided for peak compartments only, each required bilge pump shall be so arranged as to draw water from any space required to be drained.

1.3 Direct bilge suction

1.3.1

- a) *In passenger ships subject to subdivision regulations, independent power bilge pumps situated in machinery and/or boiler spaces shall have direct suctions from these spaces, except that not more than two such suctions shall be required in any one space.*
- b) *Where two or more such suctions are provided in one compartment, there shall be at least one on each side of the ship.*
- c) *The Society may require independent power bilge pumps situated in other spaces to have separate direct suctions.*

1.4 Control location

1.4.1

- a) *The spindles of the sea inlet and direct suction valves shall extend well above the engine room platform.*
- b) *Where the circulating pumps are driven by electric motors, their starting equipment shall be located at, or above, the level of the motors.*

1.5 Provision against bilge system damage

1.5.1 Damage to the bilge system

Provision shall be made to prevent the compartment served by any bilge suction pipe being flooded in the event of the pipe being severed or otherwise damaged by collision or grounding in any other compartment. For this purpose, where the pipe is at any part situated nearer the side of the ship than one fifth of the breadth of the ship (measured at right angles to the centreline at the level of the deepest subdivision load line), or is in a duct keel, a non-return valve shall be fitted to the pipe in the compartment containing the open end. The deepest subdivision load line shall be taken as the deepest subdivision draught.

1.5.2 Operation in the case of flooding

- a) *Distribution boxes, cocks and valves in connection with the bilge pumping system shall be so arranged that, in the event of flooding, one of the bilge pumps may be operative on any compartment; in addition, damage to a pump or its pipe connecting to the bilge main outboard of a line drawn at one fifth of the breadth of the ship shall not put the bilge system out of action.*
- b) *If there is only one system of pipes common to all the pumps, the necessary valves for controlling the bilge suctions must be capable of being operated from above the bulkhead deck.*
- c) *Where in addition to the main bilge pumping system an emergency bilge pumping system is provided, it shall be independent of the main system and so arranged that a pump is capable of operating on any compartment under flooding condition; in that case only the valves necessary for the operation of the emergency system need be capable of being operated from above the bulkhead deck.*

1.5.3 Valve controls

All cocks and valves referred in [1.5.2] which can be operated from above the bulkhead deck shall have their controls at their place of operation clearly marked and shall be provided with means to indicate whether they are open or closed.

1.6 Drainage and pumping arrangements for vehicle, special category and ro-ro spaces protected by fixed pressure water-spraying systems

1.6.1 *When fixed pressure water-spraying fire-extinguishing systems are fitted, in view of the serious loss of stability which could arise due to large quantities of water accumulating on the deck or decks during the operation of the fixed pressure water-spraying system, the following arrangements shall be provided:*

- a) *in the spaces above the bulkhead deck, scuppers shall be fitted so as to ensure that such water is rapidly discharged directly overboard, taking into account IMO Circular MSC.1/Circ.1320*

b)

- 1) *in ro-ro passenger ships, discharge valves for scuppers, fitted with positive means of closing operable from a position above the bulkhead deck in accordance with the requirements of the International Convention on Load Lines in force, shall be kept open while the ships are at sea*
 - 2) *any operation of valves referred to in 1) shall be recorded in the log-book*
- c) *in the spaces below the bulkhead deck, the Society may require pumping and drainage facilities to be provided additional to the requirements above and to those of Pt C, Ch 1, Sec 10. In such case, the drainage system shall be sized to remove no less than 125% of the combined capacity of both the water-spraying system pumps and the required number of fire hose nozzles. The drainage system valves shall be operable from outside the protected space at a position in the vicinity of the extinguishing system controls. Bilge wells shall be of sufficient holding capacity and shall be arranged at the side shell of the ship at a distance from each other of not more than 40 m in each watertight compartment.*

2 Ballast system

2.1

2.1.1 *Water ballast should not in general be carried in tanks intended for fuel oil. In ships in which it is not practicable to avoid putting water in fuel oil tanks, oily-water separating equipment to the satisfaction of the Society shall be fitted, or other alternative means, such as discharge to shore facilities shall be provided for disposing of the oily-water ballast.*

3 Miscellaneous requirements

3.1 Steering gear

3.1.1 For steering gear arrangements without auxiliary means for steering, see Ch 15, Sec 4, [24.3.2].

3.2 Oil-level gauges

3.2.1 For oil-level gauges, see Pt C, Ch 1, Sec 10, [11.6.7].

3.3 Watertight doors

3.3.1 For watertight doors, see Ch 11, Sec 2.

Section 5 Electrical Installations

1 General

1.1 Documentation to be submitted

1.1.1 The documentation dealing with the electrical system for watertight door and fire door systems as requested in Pt C, Ch 2, Sec 1, Tab 1, Pt B, Ch 1, Sec 4, Tab 1 and Pt C, Ch 4, Sec 1, Tab 1 is to be submitted for approval.

1.2 Electrical distribution and protection

1.2.1 *In a passenger ship, distribution systems shall be so arranged that fire in any main vertical zone as defined in Part C, Chapter 4 will not interfere with services essential for safety in any other such zone.*

This requirement will be met if main and emergency feeders passing through any such zone are separated both vertically and horizontally as widely as is practicable.

1.2.2 For generators arranged to operate in parallel and for individually operating generators, arrangements are to be made to disconnect automatically the excess load when the generators are overloaded in such a way as to prevent a sustained loss of speed. The operation of such device is to activate a visual and audible alarm.

1.3 Flooding detection systems for passenger ships carrying 36 or more persons

1.3.1 *A flooding detection system for watertight spaces below the bulkhead deck is to be provided based on IMO MSC.1/Circ.1291.*

2 Emergency source of electrical power and emergency installations

2.1 General

2.1.1 *A self-contained emergency source of electrical power shall be provided.*

2.1.2 *Provided that suitable measures are taken for safeguarding independent emergency operation under all circumstances, the emergency generator may be used, exceptionally, and for short periods, to supply non-emergency circuits.*

Exceptionally, whilst the vessel is at sea, is understood to mean conditions such as:

- a) blackout situation
- b) dead ship situation
- c) routine use for testing
- d) short-term parallel operation with the main source of electrical power for the purpose of load transfer.

Unless instructed otherwise by the Society, the emergency generator may be used during lay time in port for the supply of the ship mains, provided the requirements of Pt C, Ch 2, Sec 3, [2.4] are complied with.

2.1.3 *The electrical power available shall be sufficient to supply all those services that are essential for safety in an emergency, due regard being paid to such services as may have to be operated simultaneously.*

2.1.4 *The emergency source of electrical power shall be capable, having regard to starting currents and the transitory nature of certain loads, of supplying simultaneously at least the services stated in [2.2.3] for the period specified, if they depend upon an electrical source for their operation.*

2.1.5 *The transitional source of emergency electrical power, where required, is to be of sufficient capacity to supply at least the services stated in [2.2.7] for the periods specified therein, if they depend upon an electrical source for their operation.*

2.1.6 *An indicator shall be mounted in a suitable place on the main switchboard or in the machinery control room to indicate when the batteries constituting either the emergency source of electrical power or the transitional source of emergency electrical power referred to in Pt C, Ch 2, Sec 3, [2.3.15] and Pt C, Ch 2, Sec 3, [2.3.16] are being discharged.*

2.1.7 If the services which are to be supplied by the transitional source receive power from an accumulator battery by means of semiconductor converters, means are to be provided for supplying such services also in the event of failure of the converter (e.g. providing a bypass feeder or a duplication of converter).

2.1.8 *Where electrical power is necessary to restore propulsion, the capacity of the emergency source shall be sufficient to restore propulsion to the ship in conjunction to other machinery as appropriate, from a dead ship condition within 30 min. after blackout.*

For the purpose of this requirement only, the dead ship condition and blackout are both understood to mean a condition under which the main propulsion plant, boilers and auxiliaries are not in operation and in restoring the propulsion, no stored energy for starting the propulsion plant, the main source of electrical power and other essential auxiliaries is to be assumed available. It is assumed that means are available to start the emergency generator at all times.

The emergency generator and other means needed to restore the propulsion are to have a capacity such that the necessary propulsion starting energy is available within 30 minutes of blackout/dead ship condition as defined above. Emergency generator stored starting energy is not to be directly used for starting the propulsion plant, the main source of electrical power and/or other essential auxiliaries (emergency generator excluded).

For steam ships, the 30 minute time limit given in SOLAS can be interpreted as the time from blackout/dead ship condition defined above to light-off of the first boiler.

2.1.9 *Provision shall be made for the periodical testing of the complete emergency system and shall include the testing of automatic starting arrangements.*

2.1.10 For starting arrangements of emergency generating sets, see Pt C, Ch 1, Sec 2, [3.1].

2.1.11 *The emergency source of electrical power may be either a generator or an accumulator battery, which shall comply with the provisions of [2.1.12] or [2.1.13], respectively.*

2.1.12 *Where the emergency source of electrical power is a generator, it shall be:*

- a) *driven by a suitable prime mover with an independent supply of fuel having a flashpoint (closed cup test) of not less than 43°C*
- b) *started automatically upon failure of the electrical supply to the emergency switchboard from the main source of electrical power and shall be automatically connected to the emergency switchboard; those services referred to in [2.2.7] shall then be transferred automatically to the emergency generating set. The automatic starting system and the characteristic of the prime mover shall be such as to permit the emergency generator to carry its full rated load as quickly as is safe and practicable, subject to a maximum of 45 s, and*
- c) *provided with a transitional source of emergency electrical power according to [2.1.14].*

2.1.13 *Where the emergency source of electrical power is an accumulator battery, it shall be capable of:*

- a) *carrying the emergency electrical load without recharging while maintaining the voltage of the battery throughout the discharge period within 12% above or below its nominal voltage*
- b) *automatically connecting to the emergency switchboard in the event of failure of the main source of electrical power, and*
- c) *immediately supplying at least those services specified in [2.2.7].*

2.1.14 *The transitional source of emergency electrical power required by [2.1.12] (c) shall consist of an accumulator battery which shall operate without recharging while maintaining the voltage of the battery throughout the discharge period within 12% above or below its nominal voltage and be so arranged as to supply automatically in the event of failure of either the main or emergency source of electrical power at least the services in [2.2.7] if they depend upon an electrical source for their operation.*

2.1.15 Where the emergency and/or transitional source of power is an uninterruptible power system (UPS), it is to comply with the requirements of Pt C, Ch 2, Sec 6, [3].

2.2 Distribution of electrical power

2.2.1 *The emergency switch board shall be supplied during normal operation from the main switchboard by an interconnector feeder which shall be adequately protected at the main switchboard against overload and short-circuit and which is to be disconnected automatically at the emergency switchboard upon failure of the main source of electrical power.*

Where the system is arranged for feedback operation, the interconnector feeder is also to be protected at the emergency switchboard at least against short-circuit.

2.2.2 *In order to ensure ready availability of the emergency source of electrical power, arrangements shall be made where necessary to disconnect automatically non-emergency circuits from the emergency switchboard to ensure that power shall be available to the emergency circuits.*

2.2.3 *The emergency source of electrical power shall be capable of supplying simultaneously at least the following services for the periods specified hereafter, if they depend upon an electrical source for their operation:*

- a) for a period of 36 hours, emergency lighting:
- 1) at every muster and embarkation station and over the sides
 - 2) in alleyways, stairways and exits giving access to the muster and embarkation stations
 - 3) in all service and accommodation alleyways, stairways and exits, personnel lift cars
 - 4) in the machinery spaces and main generating stations including their control positions
 - 5) in all control stations, machinery control rooms, and at each main and emergency switchboard
 - 6) at all stowage positions for firemen's outfits
 - 7) at the steering gear, and
 - 8) at the fire pump, the sprinkler pump and the emergency bilge pump referred to in (d) below and at the starting position of their motors
- b) for a period of 36 hours:
- 1) the navigation lights and other lights required by the International Regulations for Preventing Collisions at Sea in force, and
 - 2) on ships constructed on or after 1 February 1995 the VHF radio installation required by Regulation IV/7.1.1 and IV/7.1.2 of SOLAS Consolidated Edition 1992, and, if applicable:
 - the MF radio installation required by Regulations IV/9.1.1, IV/9.1.2, IV/10.1.2 and IV/10.1.3
 - the ship earth station required by Regulation IV/10.1.1, and
 - the MF/HF radio installation required by Regulations IV/10.2.1, IV/10.2.2 and IV/11.1
- c) for a period of 36 hours:
- 1) all internal communication equipment required in an emergency (see [2.2.4])
 - 2) the shipborne navigational equipment as required by Regulation V/12; where such provision is unreasonable or impracticable the Society may waive this requirement for ships of less than 5,000 gross tonnage
 - 3) the fire detection and fire alarm system, the fire door holding and release system, and
 - 4) intermittent operation of the daylight signalling lamp, the ship's whistle, the manually operated call points and all internal signals (see [2.2.5]) that are required in an emergency, unless such services have an independent supply for the period of 36 hours from an accumulator battery suitably located for use in an emergency
- d) for a period of 36 hours:
- 1) one of the fire pumps required by the relevant provisions of Part C, Chapter 4
 - 2) the automatic sprinkler pump, if any, and
 - 3) the emergency bilge pump and all the equipment essential for the operation of electrically powered remote controlled bilge valves
- e) for the period of time required in Pt C, Ch 1, Sec 14, [2], the steering gear if required to be so supplied
- f) for a period of half an hour:
- 1) any watertight doors required by Regulation II-1/13 to be power operated together with their indicators and warning signals
 - 2) the emergency arrangements to bring the lift cars to deck level for the escape of persons. The passenger lift cars may be brought to deck level sequentially in an emergency.

2.2.4 Internal communication equipment required in an emergency generally includes:

- a) the means of communication between the navigating bridge and the steering gear compartment
- b) the means of communication between the navigating bridge and the position in the machinery space or control room from which the engines are normally controlled
- c) the means of communication which is provided between the officer of the watch and the person responsible for closing any watertight door which is not capable of being closed from a central control station
- d) the public address system or other effective means of communication throughout the accommodation, public and service spaces
- e) the means of communication between the navigating bridge and the main fire control station.

2.2.5 Internal signals required in an emergency generally include:

- a) general alarm
- b) watertight door indication
- c) fire door indication.

2.2.6 In a ship engaged regularly in voyages of short duration, i.e. voyages where the route is no greater than 20 nautical miles offshore or where the vessel has a class notation "Coastal Service", the Society if satisfied that an adequate standard of safety would be attained may accept a lesser period than the 36-hour period specified in [2.2.3] (b) to (e) but not less than 12 hours.

2.2.7 The transitional source of emergency electrical power required is to supply at least the following services if they depend upon an electrical source for their operation:

a) for half an hour:

- 1) the lighting required by [2.2.3] (b1) and Pt C, Ch 2, Sec 3, [3.6.7] (a)
- 2) all services required by [2.2.3] (c1, 3 and 4) unless such services have an independent supply for the period specified from an accumulator battery suitably located for use in an emergency

b) it is also to supply power to close the watertight doors as required by Regulation II-1/13.7.3.3, but not necessarily all of them simultaneously, unless an independent temporary source of stored energy is provided. Power to the control, indication and alarm circuits as required by Regulation II-1/13.7.2, for half an hour.

2.3 Low-location lighting

2.3.1 Passenger ships are to be provided with a low-location lighting (LLL) system in accordance with Pt C, Ch 4, Sec 8, [2.2.3].

Where LLL is satisfied by electric illumination, it is to comply with the following requirements.

2.3.2 The LLL system is to be connected to the emergency switchboard and is to be capable of being powered either by the main source of electrical power, or by the emergency source of electrical power for a minimum period of 60 minutes after energising in an emergency.

2.3.3 The power supply arrangements to the LLL are to be arranged so that a single fault or a fire in any one fire zone or deck does not result in loss of the lighting in any other zone or deck. This requirement may be satisfied by the power supply circuit configuration, use of fire-resistant cables complying with IEC Publication 60331: Fire characteristics of electrical cables, and/or the provision of suitably located power supply units having integral batteries adequately rated to supply the connected LLL for a minimum period of 60 minutes.

2.3.4 Single lights and lighting assemblies are to be designed or arranged so that any single fault or failure in a light or lighting assembly, other than a short-circuit, will not result in a break in visible delineation exceeding 1 metre.

2.3.5 Light and lighting assemblies are to be flame-retardant as a minimum, to have an ingress protection of at least IP55 and to meet the type test requirements as specified in Pt C, Ch 3, Sec 6, Tab 1.

2.3.6 The LLL system is to be capable of being manually activated by a single action from the continuously manned central control station. It may, additionally, be continuously operating or be switched on automatically, e.g. by the presence of smoke within the space(s) being served.

2.3.7 When powered, the systems are to achieve the following minimum luminance:

- for any planar source: 10 cd/m² from the active parts in a continuous line of 15 mm minimum width
- for any point source: 35 mcd in the typical track directions of approach and viewing which is to be considered:
 - for sources which are required to be viewed from a horizontal position, i.e. deck mounted or horizontally bulkhead mounted fittings, within a 60° cone having its centre located 30° from the horizontal mounting surface of the point source and in line with the track direction, see Fig 1
 - for sources which are required to be viewed vertically, i.e. the vertical LLL marking up to the door handles, within a 60° cone having its centre located perpendicular to the mounting service of the point source, see Fig 2.

Spacing between sources is not to exceed 300 mm.

2.3.8 The lights or lighting assemblies are to be continuous except as interrupted by constructional constraints, such as corridors or cabin doors etc., are to provide a visible delineation along the escape route and, where applicable, are to lead to the exit door handles. Interruption of the LLL system due to constructional constraints is not to exceed 2 metres.

2.3.9 The lighting is to be provided on at least one side of the corridor or stairway. In corridors and stairways in excess of 2 metres width, lighting is to be provided on both sides.

2.3.10 In corridors the lighting is to be installed either on the bulkhead within 300 mm of the deck or, alternatively, on the deck within 150 mm of the bulkhead.

2.3.11 In stairways the lighting is to be installed within 300 mm above the steps such that each step may be readily identified from either above or below that step. The top and bottom steps are to be further identified to show that there are no further steps.

Figure 1 :

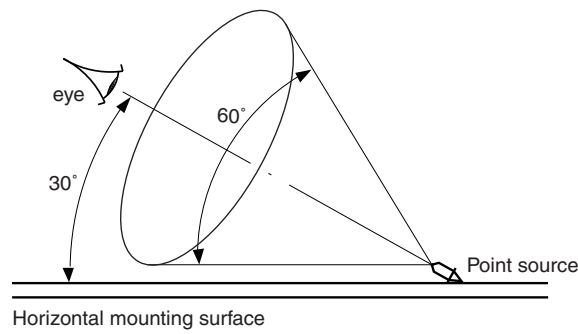
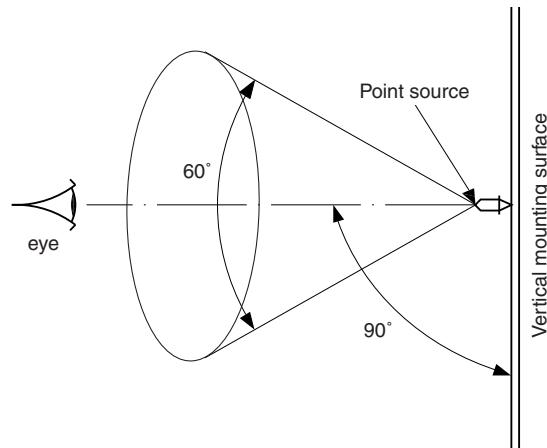

Figure 2 :



3 General emergency alarm and public address systems

3.1 General emergency alarm system

3.1.1 An electrically operated bell or klaxon or other equivalent warning system installed in addition to the ship's whistle or siren for sounding the general emergency alarm signal is to comply with the following requirements.

3.1.2 The general emergency alarm system is to be supplemented by either a public address system complying with the requirements in [3.2] or other suitable means of communication.

3.1.3 The entertainment sound system is to be automatically turned off when the general alarm system is activated.

3.1.4 The system is to be continuously powered and is to have an automatic change-over to a standby power supply in case of loss of the normal power supply.

An alarm is to be given in the event of failure of the normal power supply.

3.1.5 The system is to be powered by means of two circuits, one from the ship's main supply and the other from the emergency source of electrical power required by [2.1] and [2.2].

3.1.6 The system is to be capable of operation from the navigation bridge and, except for the ship's whistle, also from other strategic points.

Note 1: Other strategic points are taken to mean those locations, other than the navigation bridge, from where emergency situations are intended to be controlled and the general alarm system can be activated. A fire control station or a cargo control station is normally to be regarded as strategic points.

3.1.7 The alarm is to continue to function after it has been triggered until it is manually turned off or is temporarily interrupted by a message on the public address system.

3.1.8 The alarm system is to be audible throughout all the accommodation and normal crew working spaces and on all open decks.

3.1.9 The minimum sound pressure level for the emergency alarm tone in interior and exterior spaces is to be 80 dB (A) and at least 10 dB (A) above ambient noise levels existing during normal equipment operation with the ship underway in moderate weather.

3.1.10 In cabins without a loudspeaker installation, an electronic alarm transducer, e.g. a buzzer or similar, is to be installed.

3.1.11 The sound pressure level at the sleeping position in cabins and in cabin bathrooms is to be at least 75 dB (A) and at least 10 dB (A) above ambient noise levels.

3.1.12 For cables used for the general emergency alarm system, see Pt C, Ch 2, Sec 3, [9.6.1], Pt C, Ch 2, Sec 11, [5.2.1] and Pt C, Ch 2, Sec 11, [5.2.5].

3.1.13 Electrical cables and apparatus for the general emergency alarm system and their power supply are to be arranged so that the loss of the system in any one area due to localised fire is minimised.

3.1.14 Where the fire alarm to summon the crew operated from the navigating bridge or fire control station is part of the ship's general alarm system, it is to be capable of being sounded independently of the alarm in the passenger spaces.

3.2 Public address system

3.2.1 The public address system is to be one complete system consisting of a loudspeaker installation which enables simultaneous broadcast of messages from the navigation bridge, and at least one other location on board for use when the navigation bridge has been rendered unavailable due to the emergency, to all spaces where crew members or passengers, or both, are normally present (accommodation and service spaces and control stations and open decks), and to assembly stations (i.e. muster stations).

In spaces such as under deck passageways, bosun's locker, hospital and pump room, the public address system may not be required.

3.2.2 The public address system is to be arranged to operate on the main source of electrical power, the emergency source of electrical power and transitional sources of electrical power as required by Pt C, Ch 2, Sec 3, [2.3] and Pt C, Ch 2, Sec 3, [3.6].

3.2.3 The controls of the system on the navigation bridge are to be capable of interrupting any broadcast on the system from any other location on board.

3.2.4 Where an individual loudspeaker has a device for local silencing, an override arrangement from the control station(s), including the navigating bridge, is to be in place.

3.2.5 The system is not to require any action by the addressee.

3.2.6 It is to be possible to address crew accommodation and work spaces separately from passenger spaces.

3.2.7 In addition to any function provided for routine use aboard the ship, the system is to have an emergency function control at each control station which:

- a) is clearly indicated as the emergency function
- b) is protected against unauthorised use
- c) automatically overrides any other input system or program, and
- d) automatically overrides all volume controls and on/off controls so that the required volume for the emergency mode is achieved in all spaces.

3.2.8 The system is to be installed with regard to acoustically marginal conditions, so that emergency announcements are clearly audible above ambient noise in all spaces where crew members or passengers, or both, are normally present (accommodation and service spaces and control stations and open decks), and at assembly stations (i.e. muster stations).

3.2.9 With the ship underway in normal conditions, the minimum sound pressure level for broadcasting emergency announcements is to be:

- a) in interior spaces 75 dB (A) and at least 20 dB (A) above the speech interference level, and
- b) in exterior spaces 80 dB (A) and at least 15 dB (A) above the speech interference level.

Evidence of this level is to be shown with test result in open sea or equivalent quay measurement with appropriate correction factor.

3.2.10 The system is to be arranged to prevent feed-back or other interference.

3.2.11 The system is to be arranged to minimise the effect of a single failure so that the emergency messages are still audible (above ambient noise levels) also in the event of failure of any one circuit or component.

3.2.12 Each loudspeaker is to be individually protected against short-circuits.

3.2.13 For cables used for the public address system, see Pt C, Ch 2, Sec 3, [9.6.1], Pt C, Ch 2, Sec 11, [5.2.1] and Pt C, Ch 2, Sec 11, [5.2.5].

3.2.14 All areas of each fire zone are to be served by at least two dedicated loops of flame-retardant cables which are to be sufficiently separated throughout their length and supplied by two separate and independent amplifiers.

3.2.15 A temperature alarm is to be provided in the public address cabinets in case of forced air cooling.

3.3 Combined general emergency alarm - public address system

3.3.1 Where the public address system is the only means for sounding the general emergency alarm signal and the fire alarm, in addition to the requirements of [3.1] and [3.2], the following are to be satisfied:

- the system automatically overrides any other input system when an emergency alarm is required.
- the system automatically overrides any volume control provided to give the required output for the emergency mode when an emergency alarm is required.
- the system is arranged to minimise the effect of a single failure so that the alarm signal is still audible (above ambient noise levels) also in the event of failure of any one circuit or component, by means of the use of more than one device for generating an electronic sound signal.

4 Installation

4.1 Section and distribution boards

4.1.1 Cubicles and cupboards in areas which are accessible to any passenger are to be lockable.

5 Type approved components

5.1

5.1.1 Components for Low-Location Lighting systems (LLL) in passenger ship escape routes are to be type approved or in accordance with [5.1.2].

5.1.2 Case-by-case approval based on submission of adequate documentation and execution of tests may also be granted at the discretion of the Society.

Appendix 1 Calculation Method for Cross-Flooding Arrangements

1 Calculation method for cross-flooding arrangements

1.1 Definitions

1.1.1 Definitions

Σk : Sum of friction coefficients in the considered cross-flooding arrangement

S : Cross-section area, in m^2 , of the cross-flooding pipe or duct. If the cross-section area is not circular, then:

$$S_{\text{equiv}} = \frac{\pi D_{\text{equiv}}^2}{4}$$

where:

$$D_{\text{equiv}} = \frac{4A}{p}$$

A : actual cross-section area

p : actual cross-section perimeter

θ_0 : Angle, in degree, before commencement of cross-flooding. This assumes that the cross-flooding device is fully flooded but that no water has entered into the equalizing compartment on the opposite side of the damage

θ_f : Heel angle, in degree, at final equilibrium
 $\theta_f \leq \theta$

θ : Any angle of heel between the commencement of cross-flooding and the final equilibrium at a given time

W_f : Volume, in m^3 , of water which is used to bring the ship from commencement of cross-flooding θ_0 to final equilibrium θ_f

W_θ : Volume, in m^3 , of water which is used to bring the ship from any angle of heel θ to the final equilibrium θ_f

H_0 : Head of water, in m, before commencement of cross-flooding, with the same assumption as for θ_0

H_θ : Head of water, in m, when any angle of heel θ is achieved

h_f : Final head of water, in m, after cross-flooding

($h_f = 0$, when the level inside the equalizing compartment is equal to the free level of the sea).

1.2 Cross-flooding area

1.2.1 Cross-flooding area calculation

The cross-flooding area S , in m^2 , can be calculated from the following formula:

$$S = \frac{2W_f}{T_f F} \cdot \frac{\left(1 - \sqrt{\frac{h_f}{H_0}}\right)}{\sqrt{2gH_0}} \cdot \frac{1}{\left(1 - \frac{h_f}{H_0}\right)}$$

1.2.2 Calculation of time

T_f : Time required from commencement of cross flooding θ_0 to the final equilibrium θ_f

T_θ : Time required to bring the ship from any angle of heel θ to the final equilibrium θ_f

$$T_\theta = \frac{2W_\theta}{S \cdot F} \cdot \frac{\left(1 - \sqrt{\frac{h_f}{H_\theta}}\right)}{\sqrt{2gH_\theta}} \cdot \frac{1}{\left(1 - \frac{h_f}{H_\theta}\right)}$$

T : Time required from commencement of cross flooding θ_0 until any angle of heel θ is achieved:

$$T = T_f - T_\theta$$

1.2.3 Dimensionless factor F

The dimensionless factor of reduction of speed through an equalization device, being a function of bends, valves, etc., in the cross-flooding system is to be calculated as follows:

$$F = \frac{1}{\sqrt{\sum k}}$$

where *F* is not to be taken as more than 1.

Values for *k* can be obtained from [1.2.4] or other appropriate sources.

1.2.4 Factor of reduction *k*

The factor of reduction is to be calculated depending on the following cases:

- Case 1: 90° circular bend
- Case 2: radius bend R/D = 2
- Case 3: mitre bend
- Case 4: 90° double mitre bend
- Case 5: pipe inlet
- Case 6: pipe outlet
- Case 7: non-return valve
- Case 8: pipe friction losses
- Case 9: gate valve
- Case 10: butterfly valve
- Case 11: disc valve.

Case 1: 90° CIRCULAR BEND (see Fig 1)

The factor *k* is defined in Tab 1.

Figure 1 : 90° CIRCULAR BEND

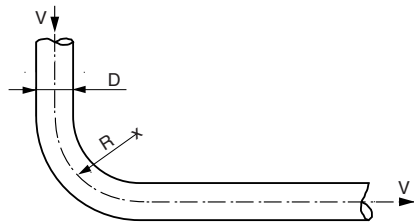

Table 1 : Values of factor *k*

R/D	2	3	4	5	6	7
<i>k</i>	.30	.26	.23	.20	.18	.17

Case 2: RADIUS BEND R/D = 2 (see Fig 2)

The factor *k* is defined in Tab 2.

Figure 2 : RADIUS BEND R/D = 2

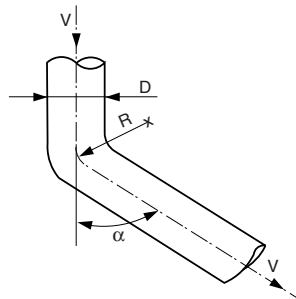

Table 2 : Values of factor *k*

α°	15	30	45	60	75	90
<i>k</i>	.06	.12	.18	.24	.27	.30

Case 3: MITRE BEND (see Fig 3)

The factor *k* is defined in Tab 3.

Figure 3 : MITRE BEND

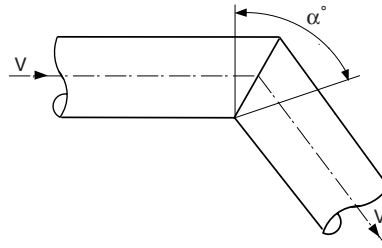

Table 3 : Values of factor k

α°	5	15	30	45	60	90
k	.02	.06	.17	.32	.68	1.26

Case 4: 90°DOUBLE MITRE BEND (see Fig 4)
The factor k is defined in Tab 4.

Figure 4 : 90° DOUBLE MITRE BEND

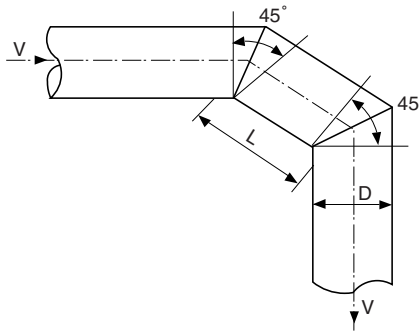

Table 4 : Values of factor k

L/D	1	2	3	4	5	6
k	.41	.40	.43	.46	.46	.44

Case 5: PIPE INLET (see Fig 5)
The factor k is defined in Tab 5.

Figure 5 : PIPE INLET

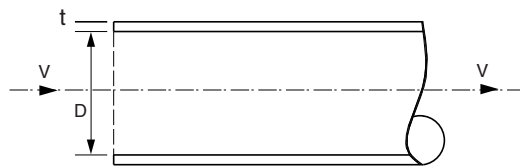
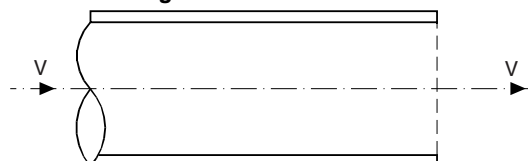

Table 5 : Values of factor k

t/D	.01	.02	.03	.04	.05	$\geq .05$
k	.83	.68	.53	.46	.44	.43

Case 6: PIPE OUTLET (see Fig 6)
k = 1.0

Figure 6 : PIPE OUTLET



Case 7: NON-RETURN VALVE (see Fig 7)

$k = 0.5$

The value of k actually increases with decrease in Froude number, particularly below speeds of 2m/sec.

Figure 7 : NON-RETURN VALVE

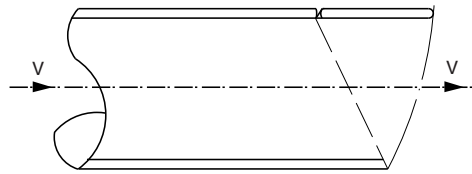

Case 8: PIPE FRICTION LOSSES

The coefficient above is a mean value and does in fact vary as Reynold's number (i.e. varies with V for constant D and v) as well as with relative roughness.

$k = 0.02/D$ per unit length

Case 9: GATE VALVE (see Fig 8)

$k = 0.3$

Figure 8 : GATE VALVE

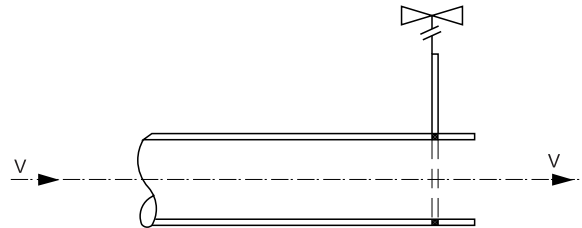

Case 10: BUTTERFLY VALVE (see Fig 9)

$k = 0.8$

Figure 9 : BUTTERFLY VALVE

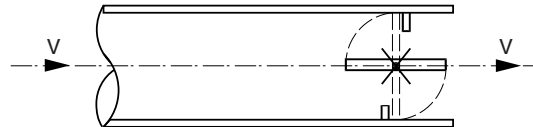

Case 11: DISC VALVE (see Fig 10)

$k = 6.0$

Figure 10 : DISC VALVE

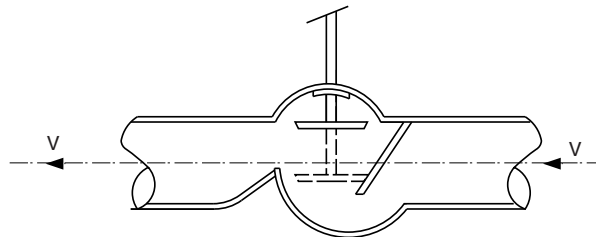

1.2.5 Cross-flooding through successive devices

If the same flow crosses successive flooding devices of cross-section S_1, S_2, S_3, \dots having corresponding friction coefficients k_1, k_2, k_3, \dots , then the total k coefficient referred to S_1 is:

$$\sum k = k_1 + k_2 \frac{S_1^2}{S_2^2} + k_3 \frac{S_1^2}{S_3^2} \dots$$

1.2.6 Different flooding devices not crossed by the same volume

If different flooding devices are not crossed by the same volume, each k coefficient is to be multiplied by the square of the ratio of the volume crossing the device and the volume crossing the reference section (which will be used for the time calculation):

$$\sum k = k_1 + k_2 \frac{S_1^2}{S_2^2} \cdot \frac{W_2^2}{W_1^2} + k_3 \frac{S_1^2}{S_3^2} \cdot \frac{W_3^2}{W_1^2} \dots$$

1.2.7 Cross flooding through devices in parallel

For cross-flooding through devices in parallel that lead to the same space, equalisation time is to be calculated assuming that:

$$SF = S_1F_1 + S_2F_2 + \dots$$

with:

$$F = \frac{1}{\sqrt{\sum k}}$$

for each device of cross section S_i .

1.2.8 Air pipe venting criteria

In arrangements where the total air pipe sectional area is 10% or more of the cross-flooding sectional area, the restrictive effect of any air back pressure may be neglected in the cross-flooding calculations. The air pipe sectional area is to be taken as the minimum or the net sectional area of any automatic closing devices, if that is less.

In arrangements where the total air pipe sectional area is less than 10% of the cross-flooding sectional area, the restrictive effect of air back pressure is to be considered in the cross-flooding calculations. The following method may be used for this purpose:

The k coefficient used in the calculation of cross-flooding time is to take into account the drop of head in the air pipe. This can be done using an equivalent coefficient k_e , which is calculated according to the following formula:

$$k_e = k_w + k_a \frac{\rho_a}{\rho_w} \cdot \left(\frac{S_w}{S_a}\right)^2$$

where:

k_w : k coefficient for the cross-flooding arrangement (water)

k_a : k coefficient for the air pipe

ρ_a : Air density

ρ_w : Water density

S_w : Cross-section area of the cross-flooding device (water)

S_a : Cross-section of air pipe

1.2.9 Alternatives

As an alternative to the provisions above, and for arrangements other than those shown in [1.2.4], direct calculation using computational fluid dynamics (CFD), time-domain simulations or model testing may also be used.

1.2.10 Examples

- Cross-flooding through a series of structural ducts with 1 manhole (see Fig 11 and Fig 12)

- if $0 < L_i < 1$:

$$k = 0,2748 L_i + 0,0313$$

- if $1 \leq L_i \leq 4$:

$$k = -0,0986 L_i^3 + 0,6873 L_i^2 - 1,0212 L_i + 0,7386$$

- if $L_i > 4$:

$$k = 1,34$$

- Cross-flooding through a series of structural ducts with 2 manholes (see Fig 13)

- if $0 < L_i < 1$:

$$k = 0,4045 L_i + 0,0627$$

- if $1 \leq L_i \leq 4$:

$$k = 0,0424 L_i^3 + 0,3593 L_i^2 - 1,1401 L_i - 0,356$$

- if $L_i > 4$:

$$k = 1,17$$

Note 1: k is the friction coefficient related to each space between two adjacent girders. k is evaluated with effective cross-section area therefore in calculations use the real cross-section area A and not S_{equiv} . The pressure loss for entrance in the first manhole is already computed in the calculation, and $k = 1$ has to be added to take into account the outlet losses.

Figure 11 : Structural duct with 1 manhole

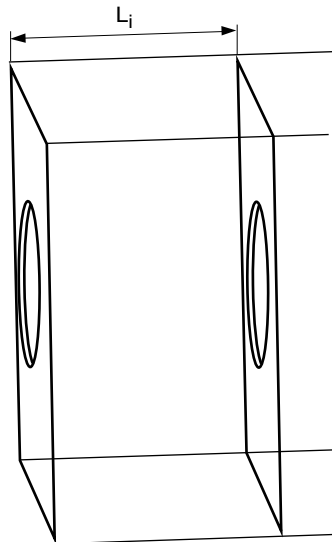

Figure 12 : Series of structural ducts with 1 manhole

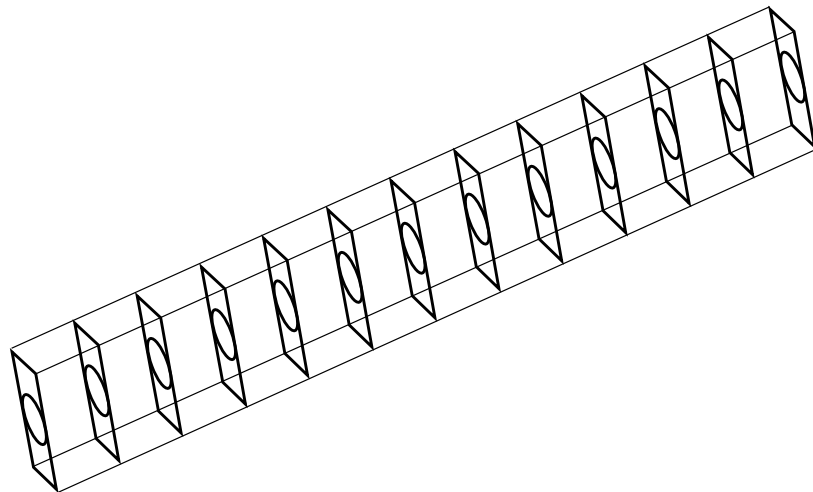
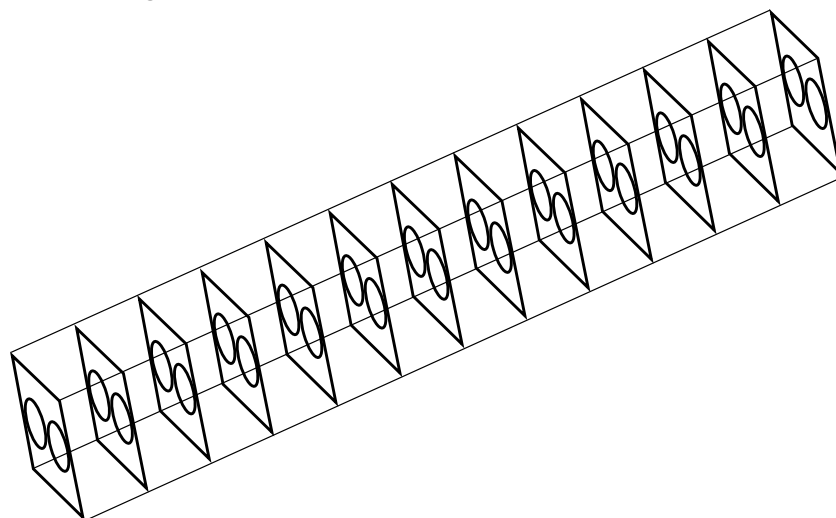

Figure 13 : Series of structural ducts with 2 manholes



Part D

Service Notations

CHAPTER 12

RO-RO PASSENGER SHIPS

Section 1	General
Section 2	Ship Arrangement
Section 3	Hull and Stability
Section 4	Electrical Installations

Section 1 General

1 General

1.1 Application

1.1.1 Ships complying with the requirements of this Chapter are eligible for the assignment of the service notation **ro-ro passenger ship**, as defined in Pt A, Ch 1, Sec 2, [4.5.3].

1.1.2 Ships dealt with in this Chapter are to comply with:

- Part A of the Rules
- NR216 Materials and Welding
- applicable requirements according to Tab 1.

1.1.3 For ships having to comply with the provisions of SOLAS Ch II-1 reg 8-1 and SOLAS Ch II-2 reg 21 and 22, the service notation **ro-ro passenger ship** is to be completed by the additional service feature **SRTP** according to requirements of NR598 Implementation of Safe Return to Port and Orderly Evacuation.

1.1.4 Additional guidance for arrangement and structural assessment is provided in NI640 Structural Assessment of Passenger Ships.

Table 1 : Applicable requirements

Item		Ships having the navigation notation unrestricted navigation	Ships having a navigation notation other than unrestricted navigation	
			Greater than or equal to 500 GT	Less than 500 GT
Ship arrangement	L ≥ 65 or 90 m (1)	<ul style="list-style-type: none"> • Part B • Ch 12, Sec 2 	<ul style="list-style-type: none"> • Part B • Ch 12, Sec 2 	<ul style="list-style-type: none"> • NR566
	L < 65 or 90 m (1)	<ul style="list-style-type: none"> • NR600 	<ul style="list-style-type: none"> • NR600 	<ul style="list-style-type: none"> • NR566
Hull	L ≥ 65 or 90 m (1)	<ul style="list-style-type: none"> • Part B • Ch 12, Sec 3 	<ul style="list-style-type: none"> • Part B • Ch 12, Sec 3 	<ul style="list-style-type: none"> • Part B • Ch 12, Sec 3
	L < 65 or 90 m (1)	<ul style="list-style-type: none"> • NR600 	<ul style="list-style-type: none"> • NR600 	<ul style="list-style-type: none"> • NR600
Stability		<ul style="list-style-type: none"> • Part B • Ch 12, Sec 3 	<ul style="list-style-type: none"> • Part B • Ch 12, Sec 3 	<ul style="list-style-type: none"> • NR566
Machinery and cargo systems		<ul style="list-style-type: none"> • Part C • Ch 1, Sec 3 • Ch 11, Sec 4 	<ul style="list-style-type: none"> • Part C • Ch 1, Sec 3 • Ch 11, Sec 4 	<ul style="list-style-type: none"> • NR566
Electrical installations		<ul style="list-style-type: none"> • Part C • Ch 12, Sec 4 	<ul style="list-style-type: none"> • Part C • Ch 12, Sec 4 	<ul style="list-style-type: none"> • NR566
Automation		<ul style="list-style-type: none"> • Part C 	<ul style="list-style-type: none"> • Part C 	<ul style="list-style-type: none"> • NR566
Fire protection, detection and extinction		<ul style="list-style-type: none"> • Part C 	<ul style="list-style-type: none"> • Part C 	<ul style="list-style-type: none"> • NR566
<p>(1) Refer to the scope of application of NR600.</p> <p>Note 1: NR566: Hull Arrangement, Stability and Systems for Ships less than 500 GT. NR600: Hull Structure and Arrangement for the Classification of Cargo Ships less than 65 m and Non Cargo Ships less than 90 m.</p>				

Section 2 Ship Arrangement

1 General

1.1 Definitions

1.1.1 Deepest subdivision load line

Deepest subdivision load line is the waterline which corresponds to the summer load line of the ship.

1.1.2 Ro-ro cargo spaces

Ro-ro cargo spaces are spaces not normally subdivided in any way and normally extending to either a substantial length or the entire length of the ship in which motor vehicles with fuel in their tanks for their own propulsion and/or goods (packaged or in bulk, in or on rail or road cars, vehicles, including road or rail tankers, trailers, containers, pallets, demountable tanks or in or on similar stowage units or other receptacles) can be loaded and unloaded normally in a horizontal direction.

1.1.3 Special category spaces

Special category spaces are those enclosed vehicle spaces above and below the bulkhead deck, into and from which vehicles can be driven and to which passengers have access. Special category spaces may be accommodated on more than one deck provided that the total overall clear height for vehicles does not exceed 10 m.

2 General arrangement design

2.1 Number and disposition of transverse watertight bulkheads

2.1.1 Where there are less transverse bulkheads than those specified in Pt B, Ch 2, Sec 1, [2.1] or where the distance between them is considered excessive by the Society, ships are to be fitted with a system of partial bulkheads, side transverse frames and deck transverses such as to provide equivalent transverse strength.

2.2 Openings in watertight bulkheads below the bulkhead deck

2.2.1 Openings in machinery spaces

Not more than one door apart from the doors to shaft tunnels may be fitted in each watertight bulkhead within spaces containing the main and auxiliary propulsion machinery including boilers serving the needs of propulsion. Where two or more shafts are fitted the tunnels are to be connected by an inter-communicating passage. Only one door is to be provided between the machinery space and the tunnel spaces where two shafts are fitted and only two doors where there are more than two shafts. All these doors are to be of the sliding type and are to be so located as to have their sills as high as practicable. The hand gear for operating these doors from above the bulkhead deck is to be situated outside the spaces containing the machinery.

Portable plates on bulkheads are not permitted except in machinery spaces. Such plates are always to be in place before the voyage commences, and are not to be removed during navigation except in the case of urgent necessity at the discretion of the Master. The necessary precautions are to be taken in replacing them to ensure that the joints are watertight. The Society may permit not more than one power-operated sliding watertight door in each watertight bulkhead larger than 1,20 m to be substituted for these portable plates, provided these doors are intended to remain closed during navigation except in the case of urgent necessity at the discretion of the Master. These doors need not meet the requirements of complete closure by hand-operated gear in 90 seconds (see Ch 11, Sec 2, [2.3.3], item e)).

2.2.2 Openings in cargo spaces

Watertight doors complying with the requirements of [2.3.1] may be fitted in watertight bulkheads dividing cargo between deck spaces. Such doors may be hinged, rolling or sliding doors but are not to be remotely controlled. They are to be fitted at the highest level and as far from the shell plating as practicable, but in no case are the outboard vertical edges to be situated at a distance from the shell plating which is less than one fifth of the breadth of the ship, such distance being measured at right angles to the centreline at the level of the deepest subdivision load line.

The doors accessible during the voyage are to be fitted with a device which prevents unauthorised opening. When it is proposed to fit such doors, the number and arrangements are to receive the special consideration of the Society.

2.2.3 Openings in ships carrying goods vehicles and accompanying personnel

This requirement applies to passenger ships designed or adapted for the carriage of goods vehicles and accompanying personnel where the total number of persons on board, other than passengers as defined in Pt A, Ch 1, Sec 2, [4.5.2], exceeds 12.

If in such a ship the total number of passengers which include personnel accompanying vehicles does not exceed:

$$N = 12 + \frac{A}{25}$$

where:

N : The maximum number of passengers for which the ship is certified

A : The total deck area, in m², of spaces available for the stowage of goods vehicles,

and where the clear height at the stowage position and at the entrance to such spaces is not less than 4 m, the provisions of [2.2.2] in respect of watertight doors apply except that the doors may be fitted at any level in watertight bulkheads dividing cargo spaces.

Additionally, indicators are required on the navigating bridge to show automatically when each door is closed and all door fastenings are secured.

2.2.4 Trunks and tunnels

Where trunkways or tunnels for access from crew accommodation to the machinery space, for piping, or for any other purpose are carried through watertight bulkheads, they are to be watertight and in accordance with the requirements of Pt B, Ch 4, Sec 5, [10.5]. The access to at least one end of each such tunnel or trunkway, if used as a passage at sea, is to be through a trunk extending watertight to a height sufficient to permit access above the bulkhead deck. The access to the other end of the trunkway or tunnel may be through a watertight door of the type required by its location in the ship. Such trunkways or tunnels are not to extend through the first subdivision bulkhead abaft the collision bulkhead.

Where trunkways in connection with refrigerated cargo and ventilation or forced draught trunks are carried through more than one watertight bulkhead, the means of closure at such openings are to be operated by power and be capable of being closed from a central position situated above the bulkhead deck.

Where a ventilation trunk passing through a structure penetrates a watertight area of the bulkhead deck, the trunk is to be capable of withstanding the water pressure that may be present within the trunk, after having taken into account the maximum heel angle during flooding, in accordance with Ch 12, Sec 3, [2.3.5].

2.2.5 Additional requirements

In addition to [2.2.1], [2.2.2], [2.2.3], and [2.2.4], the requirements reported in [2.3.3] are to be complied with.

2.3 Doors

2.3.1 Requirements for doors

The requirements relevant to the operating systems for doors complying with the prescriptions in [2.3.2] and [2.3.3] are specified in Tab 1 for doors of internal watertight bulkheads and Tab 2 for doors of external watertight boundaries below equilibrium or intermediate waterplane.

2.3.2 Construction of watertight doors

The design, materials and construction of all watertight doors are to be to the satisfaction of the Society.

Such doors are to be suitably marked to ensure that they may be properly used to provide maximum safety.

The frames of vertical watertight doors are to have no groove at the bottom in which dirt might lodge and prevent the door closing properly.

2.3.3 Doors in watertight bulkheads below the bulkhead deck

- a) Watertight doors, except as provided in [2.2.2] paragraph 1 and [2.2.3], are to be capable of being closed simultaneously from the central operating console at the navigation bridge in not more than 60 s with the ship in the upright position.
- b) The means of operation whether by power or by hand of any power-operated sliding watertight door are to be capable of closing the door with the ship listed to 15° either way. Consideration is to also be given to the forces which may act on either side of the door as may be experienced when water is flowing through the opening applying a static head equivalent to a water height of at least 1 m above the sill on the centreline of the door.
- c) Watertight door controls, including hydraulic piping and electrical cables, are to be kept as close as practicable to the bulkhead in which the doors are fitted, in order to minimise the likelihood of them being involved in any damage which the ship may sustain. The positioning of watertight doors and their controls are to be such that if the ship sustains damage within one fifth of the breadth of the ship, such distance being measured at right angles to the centreline at the level of the deepest subdivision load line, the operation of the watertight doors clear of the damaged portion of the ship is not impaired.
- d) All power-operated sliding watertight doors are to be provided with means of indication which show at all remote operating positions whether the doors are open or closed. Remote operating positions are only to be located at the navigating bridge and at the location where hand operation above the bulkhead deck is required by e).
- e) Each power-operated sliding watertight door:
 - is to move vertically or horizontally;

- *is to be normally limited to a maximum clear opening width of 1,20 m. The Society may permit larger doors only to the extent considered necessary for the effective operation of the ship provided that other safety measures, including the following, are taken into consideration:*
 - *special consideration is to be given to the strength of the door and its closing appliances in order to prevent leakages;*
 - *the door is to be located outside the damage zone B/5;*
 - *is to be fitted with the necessary equipment to open and close the door using electrical power, hydraulic power, or any other form of power that is acceptable to the Society;*
 - *is to be provided with an individual hand-operated mechanism. It is to be possible to open and close the door by hand at the door itself from either side and, in addition, close the door from an accessible position above the bulkhead deck with an all round crank motion or some other movement providing the same degree of safety acceptable to the Society. Direction of rotation or other movement is to be clearly indicated at all operating positions. The time necessary for the complete closure of the door, when operating by hand gear, may not exceed 90 s with the ship in the upright position;*
 - *is to be provided with controls for opening and closing the door by power from both sides of the door and also for closing the door by power from the central operating console at the navigation bridge;*
 - *is to be provided with an audible alarm, distinct from any other alarm in the area, which is to sound whenever the door is closed remotely by power and which is to sound for at least 5 s but no more than 10 s before the door begins to move and is to continue sounding until the door is completely closed. In the case of remote hand operation it is sufficient for the audible alarm to sound only when the door is moving. Additionally, in passenger areas and areas of high ambient noise, the Society may require the audible alarm to be supplemented by an intermittent visual signal at the door;*
 - *is to have an approximately uniform rate of closure under power. The closure time, from the time the door begins to move to the time it reaches the completely closed position, is to in no case be less than 20 s or more than 40 s with the ship in the upright position.*
- f) *The electrical power required for power-operated sliding watertight doors is to be supplied from the emergency switchboard either directly or by a dedicated distribution board situated above the bulkhead deck. The associated control, indication and alarm circuits are to be supplied from the emergency switchboard either directly or by a dedicated distribution board situated above the bulkhead deck and be capable of being automatically supplied by a transitional source of emergency electrical power in the event of failure of either the main or emergency source of electrical power.*

The transitional source of emergency electrical power is to consist of an accumulator battery suitably located for use in an emergency which is to operate without recharging while maintaining the voltage of the battery throughout the discharge period within 12% above or below its nominal voltage and be of sufficient capacity and so arranged as to supply power automatically, in the event of failure of either the main or emergency source of electrical power, to control, indication and alarm circuits at least for half an hour.

- g) *Power-operated sliding watertight doors are to have either:*
- *a centralised hydraulic system with two independent power sources each consisting of a motor and pump capable of simultaneously closing all doors. In addition, there are to be for the whole installation hydraulic accumulators of sufficient capacity to operate all the doors at least three times, i.e. closed-open-closed, against an adverse list of 15°. This operating cycle is to be capable of being carried out when the accumulator is at the pump cut-in pressure. The fluid used is to be chosen considering the temperatures liable to be encountered by the installation during its service. The power operating system is to be designed to minimise the possibility of having a single failure in the hydraulic piping adversely affect the operation of more than one door. The hydraulic system is to be provided with a low-level alarm for hydraulic fluid reservoirs serving the power-operated system and a low gas pressure group alarm or other effective means of monitoring loss of stored energy in hydraulic accumulators. These alarms are to be audible and visual and are to be situated on the central operating console at the navigating bridge; or*
 - *an independent hydraulic system for each door with each power source consisting of a motor or pump capable of opening and closing the door. In addition, there is to be a hydraulic accumulator of sufficient capacity to operate the door at least three times, i.e. closed-open-closed, against an adverse list of 15°. This operating cycle is to be capable of being carried out when the accumulator is at the pump cut-in pressure. The fluid used is to be chosen considering the temperatures liable to be encountered by the installation during its service. A low gas pressure group alarm or other effective means of monitoring loss of stored energy in hydraulic accumulators is to be provided at the central operating console on the navigation bridge. Loss of stored energy indication at each local operating position is to also be provided; or*
 - *an independent electrical system and motor for each door with each power source consisting of a motor capable of opening and closing the door. The power source is to be capable of being automatically supplied by the transitional source of emergency electrical power in the event of failure of either the main or emergency source of electrical power and with sufficient capacity to operate the door at least three times, i.e. closed-open-closed, against an adverse list of 15°.*

The transitional source of emergency electrical power is to consist of an accumulator battery suitably located for use in an emergency which is to operate without recharging while maintaining the voltage of the battery throughout the discharge period within 12% above or below its nominal voltage and be of sufficient capacity and so arranged as to supply power automatically, in the event of failure of either the main or emergency source of electrical power, to watertight doors, but not necessarily all of them simultaneously, unless an independent source of stored energy is provided.

For the systems specified above, provision is to be made as follows:

Power systems for power-operated watertight sliding doors are to be separate from any other power system. A single failure in the electrical or hydraulic power-operated systems excluding the hydraulic actuator is not to prevent the hand operation of any door.

- h) Control handles are to be provided at each side of the bulkhead at a minimum height of 1,6 m above the floor and are to be so arranged as to enable persons passing through the doorway to hold both handles in the open position without being able to set the power closing mechanism in operation accidentally. The direction of movement of the handles in opening and closing the door is to be in the direction of door movement and is to be clearly indicated.
- i) As far as practicable, electrical equipment and components for watertight doors are to be situated above the bulkhead deck and outside hazardous areas and spaces.
- j) The enclosures of electrical components necessarily situated below the bulkhead deck are to provide suitable protection against the ingress of water.
- k) Electric power, control, indication and alarm circuits are to be protected against faults in such a way that a failure in one door circuit is not to cause a failure in any other door circuit. Short-circuits or other faults in the alarm or indicator circuits of a door are not to result in a loss of power operation of that door. Arrangements are to be such that leakage of water into the electrical equipment located below the bulkhead deck is not to cause the door to open.
- l) A single electrical failure in the power operating or control system of a power-operated sliding watertight door is not to result in a closed door opening. Availability of the power supply is to be continuously monitored at a point in the electric circuit as near as practicable to each of the motors required in g). Loss of any such power supply is to activate an audible and visual alarm at the central operating console at the navigation bridge.
- m) Failure of the normal power supply of the required alarms are to be indicated by an audible and visual alarm at the central operating console at the navigation bridge.
- n) The central operating console at the navigation bridge is to have a "master mode" switch with two modes of control:
 - a "local control" mode which is to allow any door to be locally opened and locally closed after use without automatic closure, and
 - a "doors closed" mode which is to automatically close any door that is open. The "doors closed" mode is to permit doors to be opened locally and is to automatically reclose the doors upon release of the local control mechanism.The "master mode" switch is to normally be in the "local control" mode. The "doors closed" mode is to only be used in an emergency or for testing purposes. Special consideration is to be given to the reliability of the "master mode" switch.
- o) The central operating console at the navigation bridge is to be provided with a diagram showing the location of each door, with visual indicators to show whether each door is open or closed. A red light is to indicate a door is fully open and a green light is to indicate a door is fully closed. When the door is closed remotely the red light is to indicate the intermediate position by flashing. The indicating circuit is to be independent of the control circuit for each door.
- p) It is not to be possible to remotely open any door from the central operating console.
- q) All watertight doors are to be kept closed during navigation. Certain watertight doors may be permitted to remain open during navigation only if considered absolutely necessary; that is, being open is determined essential to the safe and effective operation of the ship's machinery or to permit passengers normally unrestricted access throughout the passenger area. Such determination is to be made by the Society only after careful consideration of the impact on ship operations and survivability. A watertight door permitted to remain thus open is to be clearly indicated in the ship's stability information and the damage control documentation and is always to be ready for immediate closure.
- r) All watertight doors, including sliding doors, operated by hydraulic door actuators, either a central hydraulic unit or an independent hydraulic unit for each door is to be provided with a low fluid level alarm or low gas pressure alarm, as applicable or some other means of monitoring loss of stored energy in the hydraulic accumulators. This alarm is to be both audible and visible and is to be located on the central operating console at the navigation bridge.
- s) Signboard/instructions are to be placed in way of the door advising how to act when the door closed.

2.3.4 Doors in bulkheads above the bulkhead deck

a) General

Doors are to be capable of being opened and closed by hand locally from both sides of the doors with the ship listed to 15° to either side.

Position indicators are to be provided on the bridge to show that the doors are open or closed and that the dogs are fully and properly engaged.

Where the doors also serve as fire doors they are to be provided with position indicators at the fire control station and audible alarms as required for fire doors, as well as for weathertight doors. Where two doors are fitted they must be capable of independent operation remotely and from both sides of each door.

b) Doors normally closed at sea

In addition to a), doors not required for frequent access while at sea are to be kept normally closed and may be of either hinged or sliding type.

Doors kept normally closed are to have local operation from both sides of the doors and are to be labelled on both sides: "to be kept closed at sea".

c) *Doors normally open at sea*

Where fitted in public space for the passage of passengers and crew, the doors may be kept normally open at sea and may be either hinged or sliding type.

In addition to a), doors kept normally open at sea are to have local power operation from both sides of the door and remote closing from the bridge. Operation of these doors is to be similar to that specified in Pt C, Ch 4, Sec 5 where, using a "master mode" switch on the bridge, local control can override the remote closing feature after which the door is automatically remotely reclosed upon release of the local control mechanism.

Doors kept normally open at sea are to have audible alarms, distinct from any other alarm in the area, which sound whenever the doors are closed remotely. The alarms are to sound for at least 5 s but not more than 10 s before the doors begins to move and continue sounding until the doors are completely closed. In passenger areas and areas of high ambient noise, the audible alarms are to be supplemented by visual signals at both sides of the doors.

d) *Failure of the normal power supply of the required alarms are to be indicated by an audible and visual alarm.*

e) *The following doors, located above the bulkhead deck, are to be provided with adequate means of closure and locking devices according to a) and b) above and the requirements of Pt B, Ch 11, Sec 8, [4]:*

- *cargo loading doors in the shell or the boundaries of enclosed superstructures,*
- *bow visors fitted in the shell or the boundaries of enclosed superstructures,*
- *cargo loading doors in the collision bulkhead,*
- *weathertight ramps forming an alternative closure to those previously defined.*

f) *All watertight doors, including sliding doors, operated by hydraulic door actuators, either a central hydraulic unit or an independent hydraulic unit for each door is to be provided with a low fluid level alarm or low gas pressure alarm, as applicable or some other means of monitoring loss of stored energy in the hydraulic accumulators. This alarm is to be both audible and visible and is to be located on the central operating console at the navigation bridge.*

g) *Signboard/instructions are to be placed in way of the door advising how to act when the door closed.*

2.3.5 Watertight doors above the freeboard deck

The scantlings of the watertight doors above the freeboard deck in ro-ro spaces are to be checked in accordance with the structural requirements of Part B, Chapter 7 for watertight structure in flooded conditions.

2.4 Openings in bulkheads above the bulkhead deck

2.4.1 General

Measures such as the fitting of partial bulkheads or webs are to be taken to limit the entry and spread of water above the bulkhead deck. When partial watertight bulkheads and webs are fitted on the bulkhead deck, above or in the immediate vicinity of watertight bulkheads, their connections with the shell and bulkhead deck are to be watertight so as to restrict the flow of water along the deck when the ship is in a heeled damaged condition. Where the partial watertight bulkhead does not line up with the bulkhead below, the bulkhead deck between is to be made effectively watertight. Where openings, pipes, scuppers, electric cables etc. are carried through the partial watertight bulkheads or decks within the immersed part of the bulkhead deck, arrangements are to be made to ensure the watertight integrity of the structure above the bulkhead deck.

The coamings of all openings in the exposed weather deck are to be of ample height and strength and are to be provided with efficient means for expeditiously closing them weathertight. Freeing ports, open rails and scuppers are to be fitted as necessary for rapidly cleaning the weather deck of water under all weather conditions.

Sidescuttles, gangway, cargo and fuelling ports and other means for closing openings in the shell plating above the bulkhead deck are to be of efficient design and construction and of sufficient strength (see Pt B, Ch 11, Sec 12) having regard to the spaces in which they are fitted and their positions relative to the deepest subdivision load line.

Efficient inside deadlights, so arranged that they can be easily and effectively closed and secured watertight, are to be provided for all sidescuttles to spaces below the first deck above the bulkhead deck.

2.4.2 Watertight integrity from the ro-ro deck (bulkhead deck) to spaces below

In ships subject to the provisions of [2.4.3], the lowest point of all accesses that lead to spaces below the bulkhead deck is not to be less than 2,5 m above the bulkhead deck.

2.4.3 Vehicle ramps and other accesses

Where vehicle ramps are installed to give access to spaces below the bulkhead deck, their openings are to be closed weathertight to prevent ingress of water below, alarmed and indicated to the navigation bridge.

The Society may permit the fitting of particular accesses to spaces below the bulkhead deck provided they are necessary for the essential working of the ship, e.g. the movement of machinery and stores, subject to such accesses being made watertight, alarmed and indicated on the navigation bridge.

2.4.4 Open end of air pipes

Air pipes terminating within a superstructure which are not fitted with watertight means of closure are to be considered as unprotected openings when applying Pt B, Ch 3, App 3, [1.6.11].

2.4.5 Additional requirements

In addition to [2.4.1], [2.4.2], [2.4.3] and [2.4.4], the requirements in [2.3.4] are to be complied with.

Table 1 : Doors in internal watertight bulkheads of ro-ro passenger ships

Position relative to bulkhead deck	Frequency of use while at sea	Type (1)	Remote closure	Remote indication	Audible or visual alarm	Notice
Below	Used (2)	POS	X	X	X (local)	
	Permanently closed (3) (4)	S, H				X
At or above	Used	POS, POH	X	X	X (local)	
	Used (5)	S, H		X		X
	Used (Doors giving access to below ro-ro deck)	S, H		X	X (remote)	X
	Permanently closed (3) (5)	S, H		X	X (remote)	X

(1) POS : Power operated, sliding or rolling
 POH : Power operated, hinged
 S : Sliding or rolling
 H : Hinged

(2) See SOLAS II-1/22.3 and IMO MSC.1/Circ.1564

(3) Doors are to be fitted with a device which prevents unauthorized opening

(4) Passenger ships which have to comply with [2.2.3] require an indicator on the navigation bridge to show automatically when each door is closed and all doors fastenings are secured.

(5) If hinged, this door is to be of single action type.

Table 2 : Doors in external watertight boundaries below equilibrium or intermediate waterplane

Position relative to bulkhead deck	Frequency of use while at sea	Type (1)	Remote closure	Remote indication	Audible or visual alarm	Notice
Below	Permanently closed (2)	S, H				X
At or above	Normally closed (3)	S, H		X		X
	Normally closed (Doors giving access to below ro-ro deck)	S, H		X	X (remote)	X
	Permanently closed (2)	S, H		X	X (remote)	X

(1) S : Sliding or rolling
 H : Hinged

(2) Doors are to be fitted with a device which prevents unauthorized opening

(3) If hinged, this door is to be of single action type.

2.5 Integrity of the hull and superstructure, damage prevention and control

2.5.1 Indicators are to be provided on the navigation bridge for all shell doors, loading doors and other closing appliances which, if left open or not properly secured, could, in the opinion of the Society, lead to flooding of a special category space or ro-ro cargo space. The indicator system is to be designed on the fail-safe principle and is to show by visual alarms if the door is not fully closed or if any of the securing arrangements are not in place and fully locked and by audible alarms if such door or closing appliances become open or the securing arrangements become unsecured. The indicator panel on the navigation bridge is to be equipped with a mode selection function "harbour/sea voyage" so arranged that an audible alarm is given on the navigation bridge if the ship leaves harbour with the bow doors, inner doors, stern ramp or any other side shell doors not closed or any closing device not in the correct position. The power supply for the indicator system is to be independent of the power supply for operating and securing the doors.

The sensors of the indicator system are to be protected from water, ice formation and mechanical damage.

The indication panel is to be provided with a lamp test function. It is not to be possible to turn off the indicator light.

2.5.2 Television surveillance and a water leakage detection system are to be arranged to provide an indication to the navigation bridge and to the engine control station of any leakage through inner and outer bow doors, stern doors or any other shell doors which could lead to flooding of special category spaces or ro-ro cargo spaces.

2.5.3 Special category spaces and ro-ro cargo spaces are to be continuously patrolled or monitored by effective means, such as television surveillance, so that any movement of vehicles in adverse weather conditions and unauthorised access by passengers thereto can be detected during navigation.

2.5.4 Documented operating procedures for closing and securing all shell doors, loading doors and other closing appliances which, if left open or not properly secured, could, in the opinion of the Society, lead to flooding of a special category space or ro-ro cargo space, are to be kept on board and posted at an appropriate place. The operating procedures may be included in the stability information or in the damage control booklet.

2.5.5 A closing indicator is to be fitted for the inner bow doors which constitute a prolongation of the collision bulkhead above the bulkhead deck as requested in [2.5.1].

2.6 Ballast compartment arrangement

2.6.1 Water ballast is not to, in general, be carried in tanks intended for fuel oil. In ships in which it is not practicable to avoid putting water in fuel oil fuel, oily-water separating equipment to the satisfaction of the Society is to be fitted, or other alternative means, such as discharge to shore facilities, acceptable to the Society is to be provided for disposing of the oily-water ballast (see Pt C, Ch 1, Sec 10, [7]).

2.7 Machinery compartment arrangement

2.7.1 When longitudinal bulkheads are fitted in the machinery space, adequate self-operating arrangements are to be provided in order to avoid excessive heel after damage.

Where such arrangements are cross-flooding systems, their area is to be calculated in accordance with the requirements in Ch 11, App 1. In addition, such systems are to comply with the criteria for the maximum time necessary to cross flood according to Ch 12, Sec 3, [2.3.5], item a).

2.8 Passenger spaces in ro-ro ships

2.8.1 No passenger spaces are permitted within the enclosed ro-ro decks.

Section 3 Hull and Stability

1 General

1.1 Documents to be submitted

1.1.1 In addition to the documentation requested in Part B, the following documents are to be submitted:

- operating and maintenance manual (see Pt B, Ch 11, Sec 6 and Pt B, Ch 11, Sec 7) of bow and stern doors and ramps
- plan of design loads on deck as specified in [4.1.1]
- plan of arrangement of motor vehicles, railway cars and/or other types of vehicles which are intended to be carried and indicating securing and load bearing arrangements
- characteristics of motor vehicles, railways cars and/or other types of vehicles which are intended to be carried: (as applicable) axle load, axle spacing, number of wheels per axle, wheel spacing, size of tyre print

2 Stability

2.1 Definitions

2.1.1 Deepest subdivision draught

The deepest subdivision draught (d_s) is the waterline which corresponds to the summer load line draught of the ship.

2.1.2 Light service draught

Light service draught (d_L) is the service draught corresponding to the lightest anticipated loading and associated tankage, including, however, such ballast as may be necessary for stability and/or immersion.

2.1.3 Partial subdivision draught

The partial subdivision draught (d_p) is the light service draught plus 60% of the difference between the light service draught and the deepest subdivision draught.

2.1.4 Subdivision length L_s

The subdivision length L_s is the greatest projected moulded length of that part of the ship at or below deck or decks limiting the vertical extent of flooding with the ship at the deepest subdivision draught.

2.1.5 Machinery space

Machinery spaces are spaces between the watertight boundaries of a space containing the main and auxiliary propulsion machinery, including boilers, generators and electric motors primarily intended for propulsion. In the case of unusual arrangements, the Society may define the limits of the machinery spaces.

2.1.6 Other definitions

Mid-length is the mid point of the subdivision length of the ship.

Aft terminal is the aft limit of the subdivision length.

Forward terminal is the forward limit of the subdivision length.

Breadth B is the greatest moulded breadth, in m, of the ship at or below the deepest subdivision draught.

Draught d is the vertical distance, in m, from the moulded baseline at mid-length to the waterline in question.

Permeability μ of a space is the proportion of the immersed volume of that space which can be occupied by water.

2.2 Intact stability

2.2.1 General

Every passenger ship regardless of size is to be inclined upon its completion. The lightship displacement and the longitudinal, transverse and vertical position of its centre of gravity shall be determined. The Master is to be supplied with such information satisfactory to the Society as is necessary to enable him by rapid and simple processes to obtain accurate guidance as to the stability of the ship under varying conditions of service. A copy of the stability information is to be furnished to the Society.

Where any alterations are made to a ship so as to materially affect the stability information supplied to the Master, amended stability information is to be provided. If necessary the ship is to be re-inclined.

2.2.2 Periodical lightweight check

At periodical intervals not exceeding five years, a lightweight survey is to be carried out on all passenger ships to verify any changes in lightship displacement and longitudinal centre of gravity. The ship is to be re-inclined whenever, in comparison with the approved stability information, a deviation from the lightship displacement exceeding 2% or a deviation of the longitudinal centre of gravity exceeding 1% of L is found, or anticipated.

2.2.3 Standard requirements

In addition to Pt B, Ch 3, Sec 2, [2], the requirements in [2.2.4] to [2.2.6] are to be complied with for the loading conditions defined in Pt B, Ch 3, App 2, [1.2.1] and Pt B, Ch 3, App 2, [1.2.9].

2.2.4 Crowding of passengers

The angle of heel on account of crowding of passengers to one side as defined below may not exceed 10°:

- a minimum weight of 75 kg is to be assumed for each passenger except that this value may be increased subject to the approval of the Society. In addition, the mass and distribution of the luggage is to be approved by the Society;
- the height of the centre of gravity for passengers is to be assumed equal to:
 - 1,0 m above deck level for passengers standing upright. Account may be taken, if necessary, of camber and sheer of deck; and
 - 0,3 m above the seat in respect of seated passengers.
- passengers and luggage are to be considered to be in the spaces normally at their disposal;
- passengers without luggage are to be considered as distributed to produce the most unfavourable combination of passenger heeling moment and/or initial metacentric height, which may be obtained in practice. In this connection, a value higher than four persons per square metre is not necessary.

2.2.5 Maximum turning angle

The angle of heel on account of turning may not exceed 10° when calculated using the following formula:

$$M_R = 0,02 \frac{V_0^2}{L_S} \Delta \left(KG - \frac{T_1}{2} \right)$$

where:

- M_R : Heeling moment, in t.m
- V_0 : Service speed, in m/s
- T_1 : Mean draught, in m
- KG : Height of centre of gravity above keel, in m.

2.2.6 Where anti-rolling devices are installed in a ship, the Society is to be satisfied that the above criteria can be maintained when the devices are in operation.

2.2.7 Stability booklet for ro-ro ships

The stability booklet of ro-ro ships is to contain information concerning the importance of securing and maintaining all closure watertight integrity, due to the rapid loss of stability which may result when water enters the vehicle deck and the fact capsizing can rapidly occur.

2.3 Damage stability for ships where SDS notation has been required

2.3.1 General

The requirements of this Section are to be applied to passenger ships in conjunction with the exploratory notes as set out by the IMO Resolution MSC 429(98).

2.3.2 Required subdivision index R

The required subdivision index R of a passenger ship according to the total number of persons on board is defined in Tab 1. These regulations are intended to provide ships with a minimum standard of subdivision. In addition to these requirements, the requirements of [2.3.12] are to be complied with.

Table 1 : Required subdivision index R

Total number of persons on board N	R
N < 400	0,722
400 ≤ N ≤ 1350	N / 7580 + 0,66923
1350 < N ≤ 6000	0,0369 Ln (N + 89,048) + 0,579
N > 6000	1 - (852,5 + 0,03875 N) / (N + 5000)

2.3.3 Attained subdivision index A

The attained subdivision index A is to be calculated in accordance with Pt B, Ch 3, App 3, [1.4].

The partial indices A_s , A_p and A_L are not to be less than 0,9 R.

2.3.4 Calculation of the factor p_i

The factor p_i is to be calculated in accordance with Pt B, Ch 3, App 3, [1.5].

2.3.5 Calculation of the factor s_i

The factor s_i is to be determined for each case of assumed flooding, involving a compartment or group of compartments, in accordance with the following notations and the provisions in this regulation.

θ_e : The equilibrium heel angle in any stage of flooding, in degrees

θ_v : The angle, in any stage of flooding, where the righting lever becomes negative, or the angle at which an opening incapable of being closed weathertight becomes submerged

In applying this criterion, openings which are incapable of being closed weathertight include ventilators that have to remain open to supply air to the engine room or emergency generator room for the effective operation of the ship.

GZ_{max} : The maximum positive righting lever, in metres, up to the angle θ_v

Range : The Range of positive righting levers, in degrees, measured from the angle θ_e . The positive range is to be taken up to the angle θ_v

Flooding stage is any discrete step during the flooding process, including the stage before equalization (if any) until final equilibrium has been reached.

The factor $s_{i'}$ for any damage case at any initial loading condition, $d_{i'}$, shall be obtained from the formula:

$$s_i = \min[s_{intermediate,i}, (s_{final,i} \cdot s_{mom,i})]$$

where:

$s_{intermediate,i}$: The probability to survive all intermediate flooding stages until the final equilibrium stage, and is calculated in accordance with item a)

$s_{final,i}$: The probability to survive in the final equilibrium stage of flooding. It is calculated in accordance with item b)

$s_{mom,i}$: The probability to survive heeling moments, and is calculated in accordance with item c)

a) Calculation of $s_{intermediate}$:

The factor $s_{intermediate,i}$ is to be taken as the least of the s -factors obtained from all flooding stages including the stage before equalization, if any, and is to be calculated as follows:

$$s_{intermediate,i} = \left[\frac{GZ_{max}}{0,05} \cdot \frac{Range}{7} \right]^{\frac{1}{4}}$$

where GZ_{max} is not to be taken as more than 0,05 m and Range as not more than 7°.

$s_{intermediate} = 0$, if the intermediate heel angle exceeds 15°.

Where cross-flooding fittings are required, the time for equalization is not to exceed 10 min. The time for equalization is to be calculated in accordance with Ch 11, App 1

b) Calculation of s_{final} :

The factor $s_{final,i}$ is to be obtained from the formula:

$$s_{final,i} = K \left[\frac{GZ_{max}}{TGZ_{max}} \cdot \frac{Range}{T_{Range}} \right]^{\frac{1}{4}}$$

where:

GZ_{max} is not to be taken as more than TGZ_{max}

Range is not to be taken as more than T_{Range}

TGZ_{max} is taken equal to:

- $TGZ_{max} = 0,20$ m for ro-ro passenger ships each damage case that involves a ro-ro space
- $TGZ_{max} = 0,12$ m otherwise

T_{Range} is taken equal to:

- $T_{Range} = 20^\circ$ for ro-ro passenger ships each damage case that involves a ro-ro space,
- $T_{Range} = 16^\circ$ otherwise

K is taken equal to:

- $K = 1$ if $\theta_e \leq \theta_{min}$
- $K = 0$ if $\theta_e \geq \theta_{max}$

• $K = \sqrt{\frac{\theta_{max} - \theta_e}{\theta_{max} - \theta_{min}}}$ otherwise

where:

θ_{min} is equal to 7°

θ_{max} is equal to 15°.

c) Calculation of s_{mom} :

The factor $s_{mom,i}$ is to be calculated at the final equilibrium from the formula:

$$s_{mom,i} = \frac{(GZ_{max} - 0,04) \text{ Displacement}}{M_{heel}}$$

where:

$$s_{mom,i} \leq 1$$

Displacement is the intact displacement at the respective draught (d_s, d_p, d_l)

M_{heel} is the maximum assumed heeling moment as calculated as follows:

$$M_{heel} = \max[M_{passenger}, M_{wind}, M_{survivalcraft}]$$

where heeling moments $M_{passenger}$, M_{wind} and $M_{survivalcraft}$ are calculated in [2.3.11].

2.3.6 Equalization arrangements

Unsymmetrical flooding is to be kept to a minimum consistent with the efficient arrangements. Where it is necessary to correct large angles of heel, the means adopted shall, where practicable, be self-acting, but in any case where controls to equalization devices are provided they are to be operable from above the bulkhead deck. These fittings together with their controls are to be acceptable to the Society. Suitable information concerning the use of equalization devices are to be supplied to the master of the ship.

Tanks and compartments taking part in such equalization are to be fitted with air pipes or equivalent means of sufficient cross-section to ensure that the flow of water into the equalization compartments is not delayed.

2.3.7 Cases where s_i is to be equal to zero

The factor s_i is to be taken as zero in those cases where the final waterline, taking into account sinkage, heel and trim, immerses:

- the lower edge of openings through which progressive flooding may take place and such flooding is not accounted for in the calculation of factor s_i . Such openings are to include air-pipes, ventilators and openings which are closed by means of weathertight doors or hatch covers, but the openings closed by means of watertight manhole covers and flush scuttles, small watertight hatch covers, remotely operated sliding watertight doors, side scuttles of the non-opening type as well as watertight access doors and hatch covers required to be kept closed at sea need not be considered.
- any part of the bulkhead deck considered a horizontal evacuation route.

The factor s_i is to be taken as zero if, taking into account sinkage, heel and trim, any of the following occur in any intermediate stage or in the final stage of flooding:

- immersion of any vertical escape hatch in the bulkhead deck intended for compliance with the applicable requirements of Pt C, Ch 4, Sec 8
- any controls intended for the operation of watertight doors, equalization devices, valves on piping or on ventilation ducts intended to maintain the integrity of watertight bulkheads from above the bulkhead deck become inaccessible or inoperable
- immersion of any part of piping or ventilation ducts located within the assumed extent of damage and carried through a watertight boundary if this can lead to the progressive flooding of compartment not assumed as flooded.

2.3.8 Calculation of the factor v_i

Where horizontal watertight boundaries are fitted above the waterline under consideration the s -value calculated for the lower compartment or group of compartments is to be obtained by multiplying the value as determined in [2.3.5] by the reduction factor v_m defined below, which represents the probability that the spaces above the horizontal subdivision will not be flooded.

The factor v_i is to be calculated in accordance with Pt B, Ch 3, App 3, [1.6.10] and Pt B, Ch 3, App 3, [1.6.11].

2.3.9 Contribution dA to the index A

The contribution dA to the index A is to be calculated in accordance with Pt B, Ch 3, App 3, [1.6.12].

2.3.10 Permeability

For the purpose of the subdivision and damage stability calculations of the regulations, the permeability of each general compartment or part of a compartment is to be according to Tab 2.

Other figures for permeability may be used if substantiated by calculations.

The permeability of the Ro-Ro spaces is to be as per Tab 3.

Table 2 : Values of permeability

Spaces	Permeability
Appropriated to stores	0,60
Occupied by accommodation or voids	0,95
Occupied by machinery	0,85
Intended for liquids	0 or 0,95 (1)
(1) whichever results in the more severe requirements.	

Table 3 : Permeability of Ro-Ro spaces

Permeability at draught:		
d_s	d_p	d_L
0,90	0,90	0,95

2.3.11 Inclining moments

The following inclining moments are to be taken into account:

a) *Moment due to the crowding of passengers:*

$M_{passenger}$ is the maximum assumed heeling moment resulting from movement of passengers, and is to be obtained as follows:

$$M_{passenger} = (0,075 N_p) (0,45 B) \text{ (tm)}$$

where:

N_p : Maximum number of passengers permitted to be on board in the service condition corresponding to the deepest subdivision draught under consideration; and

B : Breadth of the ship.

Alternatively, the heeling moment may be calculated assuming the passengers are distributed with 4 persons per square metre on available deck areas towards one side of the ship on the decks where muster stations are located and in such a way that they produce the most adverse heeling moment. In doing so, a weight of 75 kg per passenger is to be assumed.

b) *Moment due to launching of all fully loaded davit-launched survival craft on one side:*

$M_{survivalcraft}$ is the maximum assumed heeling moment due to the launching of all fully loaded davit-launched survival craft on one side of the ship. It shall be calculated using the following assumptions:

- all lifeboats and rescue boats fitted on the side to which the ship has heeled after having sustained damage are to be assumed to be swung out fully loaded and ready for lowering
- for lifeboats which are arranged to be launched fully loaded from the stowed position, the maximum heeling moment during launching is to be taken
- a fully loaded davit-launched liferaft attached to each davit on the side to which the ship has heeled after having sustained damage is to be assumed to be swung out ready for lowering
- persons not in the life-saving appliances which are swung out are not to provide either additional heeling or righting moment
- life-saving appliances on the side of the ship opposite to the side to which the ship has heeled are to be assumed to be in a stowed position.

c) *Moment due to wind pressure:*

M_{wind} is the maximum assumed wind force acting in a damage situation:

$$M_{wind} = (P A Z) / 9,806 \cdot 10^3 \text{ (tm)}$$

P : Wind pressure

$$P = 120 \text{ N/m}^2$$

A : Projected lateral area above waterline

z : Distance from centre of lateral projected area above waterline to $T/2$; and

T : Ship's draught, d_1 .

2.3.12 Special requirements concerning stability

A passenger ship intended to carry 400 or more persons is to have watertight subdivision abaft the collision bulkhead so that $s_i = 1$ for a damage involving all the compartments with 0.08L measured from the forward perpendicular for the three loading conditions used to calculate the attained subdivision index A. If the attained subdivision index A is calculated for different trims, this requirement shall also be satisfied for those loading conditions.

A passenger ship intended to carry 36 or more persons is to be capable of withstanding damage along the side shell to an extent specified below. Compliance with this regulation is to be achieved by demonstrating that s_i , as defined in [2.3.5], is not less than

0,9 for the three loading conditions used to calculate the attained subdivision index A. If the attained subdivision index A is calculated for different trims, this requirement is also to be satisfied for those loading conditions.

The damage extent to be assumed when demonstrating compliance with the above paragraph, is to be dependent on the total number of persons carried, and L , such that:

- the vertical extent of damage is to extend from the ships moulded baseline to a position up to 12,5 m above the position of the deepest subdivision draught as defined in Ch 11, Sec 3, [2.1], unless a lesser vertical extent of damage were to give a lower value of s_i in which case this reduced extent is to be used.
- where 400 or more persons are to be carried, a damage length of $0,03 L_s$ but not less than 3 m is to be assumed at any position along the side shell, in conjunction with a penetration inboard of $0,1 B$ but not less than 0,75 m measured inboard from the ship side, at right angles to the centreline at the level of the deepest subdivision draught.
- where less than 400 persons are carried, damage length is to be assumed at any position along the shell side between transverse watertight bulkheads provided that the distance between two adjacent transverse watertight bulkheads is not less than the assumed damage length. If the distance between adjacent transverse watertight bulkheads is less than the assumed damage length, only one of these bulkheads is to be considered effective for the purpose of demonstrating compliance with the criteria $s_i \geq 0,9$.
- where 36 persons are carried, a damage length of $0,015 L_s$ but not less than 3 m is to be assumed, in conjunction with a penetration inboard of $0,05 B$ but not less than 0,75 m.
- where more than 36, but fewer than 400 persons are carried the values of damage length and penetration inboard, used in the determination of the assumed extent of damage, are to be obtained by linear interpolation between the values of damage length and penetration which apply for ships carrying 36 persons and 400 persons.

2.3.13 Documents to be supplied

The master is to be supplied with such information to the satisfaction of the Society as is necessary to enable him by rapid and simple processes to obtain accurate guidance as to the stability of the ship under varying conditions of service. A copy of the stability information shall be furnished to the Society.

The information should include:

- curves or tables of minimum operational metacentric height (GM) and minimum permissible trim versus draught which assures compliance with the intact and damage stability requirements where applicable, alternatively corresponding curves or tables of the maximum allowable vertical centre of gravity (KG) and maximum permissible trim versus draught, or with the equivalents of either of these curves or tables.
- instructions concerning the operation of cross-flooding arrangements
- all other data and aids which might be necessary to maintain the required intact stability and stability after damage.

The intact and damage stability information specified above are to be presented as consolidated data and encompass the full operating range of draught and trim. Applied trim values shall coincide in all stability information intended for use on board. Information not required for determination of stability and trim limits should be excluded from this information.

If the damage stability is calculated in accordance with the present sub-article, a stability limit curve is to be determined using linear interpolation between the minimum required GM assumed for each of the three draughts d_s , d_p and d_l . When additional subdivision indices are calculated for different trims, a single envelope curve based on the minimum values from this calculations is to be presented. When it is intended to develop curves of maximum permissible KG, it is to be ensured that the resulting maximum KG curves correspond with a linear variation of GM.

As an alternative to a single envelope curve, the calculations for additional trims may be carried out with one common GM for all of the trims assumed at each subdivision draught. The lowest values of each partial index A_s , A_p and A_l across these trims shall then be used in the summation of the attained subdivision index A according to [2.3.3]. This will result in one GM limit curve based on the GM used at each draught. A trim limit diagram showing the assumed trim range shall be developed.

When curves or tables of minimum operational metacentric height (GM) or maximum allowable KG versus draught are not provided, the master is to ensure that the operating condition does not deviate from approved loading conditions, or verify by calculation that the stability requirement are satisfied for this loading condition.

2.3.14 Damage control documentation

Plans showing clearly for each deck and hold the boundaries of the watertight compartments, the openings therein with the means of closure and position of any controls thereof, and the arrangements for the correction of any list due to flooding are to be permanently exhibited for the guidance of the officer in charge of the ship. In addition, booklets containing the aforementioned information are to be made available to the officers of the ship.

Detailed description of the information to be included in the damage control documentation is reported in Pt B, Ch 3, Sec 3, [4].

3 Structure design principles

3.1 General

3.1.1 Wood sheathing is recommended for caterpillar trucks and unusual vehicles.

It is recommended that a piece of wood of suitable thickness should be fitted under each crutch in order to distribute the mass over the plate and the nearest stiffeners.

3.2 Hull structure

3.2.1 Framing

In general, the strength deck and the bottom are to be longitudinally framed.

Where a transverse framing system is adopted for such ships, it is to be considered by the Society on a case by case basis.

3.2.2 Side structures

Where decks are fitted with ramp openings adjacent to the ship's side, special consideration is to be given to the supports for the side framing.

4 Design loads

4.1 Loads on deck

4.1.1 Plan of design loads on deck

A plan of design static loads on deck, including fork lift areas, axle loads and any tyre print areas of wheeled loads, is to be provided for information.

All values displayed on this plan are to be at least equivalent to the values given by the present Rules for each kind of load.

4.2 Lowest 0,5 m of bulkheads forming vertical division along escape routes

4.2.1 The still water and inertial pressures transmitted to the structures *belonging to lowest 0,5 m of bulkheads and other partitions forming vertical divisions along escape routes* are to be obtained, in kN/m², as specified in Pt B, Ch 5, Sec 6, [6.1], where the value p_{dl-s} is to be taken not less than 1,5 kN/m² to allow them to be used as walking surfaces from the side of the escape route with the ship at large angles of heel.

5 Hull girder strength

5.1 Basic criteria

5.1.1 Strength deck

In addition to the requirements in Pt B, Ch 6, Sec 1, [1.3], the contribution of the hull structures up to the strength deck to the longitudinal strength is to be assessed through a finite element analysis of the whole ship in the following cases:

- when the size of openings in the side shell and/or longitudinal bulkheads located below the deck assumed by the Designer as the strength deck decrease significantly the capability of the plating to transmit shear forces to the strength deck
- when the ends of superstructures which are required to contribute to longitudinal strength may be considered not effectively connected to the hull structures in way.

5.2 Global transverse strength

5.2.1 The behaviour of the ship primary structural members under racking effects due to transverse forces induced by transverse accelerations is to be investigated according to Pt B, Ch 7, App 1, or by means of a complete ship model according to NI640 considering the loading conditions and load cases defined in Pt B, Ch 7, App 1, [4.1.2].

6 Hull scantlings

6.1 Plating

6.1.1 Lowest 0,5 m of bulkheads forming vertical division along escape routes

The net thickness of plating belonging to the lowest 0,5 m of bulkheads and other partitions forming vertical divisions along escape routes is to be obtained according to Pt B, Ch 7, Sec 4, where the loads are defined in [4.2.1].

6.2 Ordinary stiffeners

6.2.1 Lowest 0,5 m of bulkheads forming vertical division along escape routes

The net scantlings of ordinary stiffeners belonging to the lowest 0,5 m of bulkheads and other partitions forming vertical divisions along escape routes are to be obtained according to Pt B, Ch 7, Sec 5, where the loads are defined in [4.2.1].

6.3 Primary supporting members

6.3.1 Double bottom structures

In ships where pillars are widely spaced and transmit very high loads to the double bottom, the net scantlings of double bottom structures are to be considered by the Society on a case-by-case basis, taking into account the results of direct calculations.

Where deemed necessary, on the basis of the above results, additional floors and bottom girders may be required.

6.3.2 Lowest 0,5 m of bulkheads forming vertical division along escape routes

The net scantlings of primary supporting members belonging to the lowest 0,5 m of bulkheads and other partitions forming vertical divisions along escape routes are to be obtained according to Pt B, Ch 7, Sec 6, where the loads are defined in [4.2.1].

7 Other structures

7.1 Superstructures and deckhouses

7.1.1 *Where a ventilation trunk passing through a structure penetrates the bulkhead deck, the trunk is to be capable of withstanding the water pressure that may be present within the trunk, after having taken into account the maximum heeling angle allowable during intermediate stages of flooding, in accordance with the criteria in [2.3.5].*

7.1.2 *Where all or part of the penetration of the bulkhead deck is on the main ro-ro deck, the trunk is to be capable of withstanding impact pressure due to internal water motions (sloshing) of water trapped in the ro-ro deck, to be calculated according to the applicable formulae in Pt B, Ch 5, Sec 6, [2].*

8 Construction and testing

8.1 Special structural details

8.1.1 The specific requirements in Pt B, Ch 13, Sec 5, [2] for ships with the service notation **ro-ro passenger ship** are to be complied with.

Section 4 Electrical Installations

1 General

1.1 Applicable requirements

1.1.1 In addition to the relevant requirements of Part C, Chapter 2 and Ch 11, Sec 5 and those contained in this Section, electrical installations in spaces intended for the carriage of motor vehicles with fuel in their tanks for their propulsion are to comply with those of Part C, Chapter 4.

1.2 Documentation to be submitted

1.2.1 In addition to the documentation requested in Pt C, Ch 2, Sec 1, Tab 1, the following are to be submitted for approval:

- a) plan of hazardous areas
- b) document giving details of types of cables and safety characteristics of the equipment installed in hazardous areas
- c) diagrams of indicator systems for shell doors, loading doors and similar appliances, television surveillance or water leakage detection systems
- d) diagrams of the supplies to the supplementary emergency lighting systems.

1.3 Safety characteristics

1.3.1 The explosion group and temperature class of electrical equipment of a certified safe type for use with explosive petrol-air mixtures are to be at least IIA and T3.

1.4 Flooding detection systems for passenger ships carrying 36 or more persons

1.4.1 A flooding detection system for watertight spaces below the bulkhead deck is to be provided based on IMO MSC.1/Circ.1291.

2 Supplementary emergency lighting

2.1

2.1.1 In addition to the emergency lighting required in Ch 11, Sec 5, [2.2], on every passenger ship with ro-ro cargo spaces or special category spaces:

- a) all passenger public spaces and alleyways shall be provided with supplementary electric lighting that can operate for at least three hours when all other sources of electrical power have failed and under any condition of heel. The illumination provided shall be such that the approach to the means of escape can be readily seen. The source of power for the supplementary lighting shall consist of accumulator batteries located within the lighting units that are continuously charged, where practicable, from the emergency switchboard. Alternatively, any other means of lighting which is at least as effective may be accepted by the Society. The supplementary lighting shall be such that any failure of the lamp will be immediately apparent. Any accumulator battery provided shall be replaced at intervals having regard to the specified service life in the ambient conditions that they are subject to in service;
- b) a portable rechargeable battery operated lamp shall be provided in every crew space alleyway and recreational space and every working space which is normally occupied unless supplementary emergency lighting, as required in (a), is provided.

3 Installation

3.1 Installations in special category spaces situated above the bulkhead deck

3.1.1 On any deck or platform, if fitted, on which vehicles are carried and on which explosive vapours might be expected to accumulate, except platforms with openings of sufficient size permitting penetration of petrol gases downwards, electrical equipment and cables are to be installed at least 450 mm above the deck or platform.

Electrical equipment is to be as stated in Pt C, Ch 2, Sec 3, [10.1.7] and electrical cables as stated in Pt C, Ch 2, Sec 3, [10.3.3].

3.1.2 Where the installation of electrical equipment and cables at less than 450 mm above the deck or platform is deemed necessary for the safe operation of the ship, the electrical equipment is to be of a certified safe type as stated in Pt C, Ch 2, Sec 3, [10.1.6] and the electrical cables are to be as stated in Pt C, Ch 2, Sec 3, [10.3.2].

3.1.3 Electrical equipment and cables in exhaust ventilation ducts are to be as stated in [3.1.2].

3.1.4 The requirements in this item are summarised in Tab 1.

3.2 Installations in special category spaces situated below the bulkhead deck

3.2.1 Any electrical equipment installed is to be as stated in Pt C, Ch 2, Sec 3, [10.1.6] and electrical cables are to be as stated in Pt C, Ch 2, Sec 3, [10.3.2].

3.2.2 Electrical equipment and cables in exhaust ventilation ducts are to be as stated in [3.2.1].

3.2.3 The requirements in this item are summarised in Tab 2.

3.3 Installations in cargo spaces other than special category spaces intended for the carriage of motor vehicles

3.3.1 The requirements for installations in special category spaces situated below the bulkhead deck, as stated in [3.2], apply.

3.3.2 All electric circuits terminating in cargo holds are to be provided with multipole linked isolating switches located outside the holds. Provision is to be made for locking in the off position.

This requirement does not apply to safety installations such as fire, smoke or gas detection systems.

3.4 Protection of socket outlets in vehicle spaces

3.4.1 The provisions of [3.4.2] to [3.4.7] are applicable to socket outlets with a rated current not exceeding 63A in AC installations and 16A in DC installations. Socket outlets with higher rated current will be subject to special consideration by the Society.

Table 1 : Electrical equipment permitted in special category spaces above the bulkhead deck

No	Description of spaces	Electrical equipment	Hazardous area
1	Areas at less than 450 mm above the deck or platforms for vehicles, if fitted, without openings of sufficient size permitting penetration of petrol gases downward	Electrical equipment complying with one of the following types of protection may be considered: a) any type that may be considered for zone 0 b) certified intrinsically safe apparatus Ex(ib) c) simple electrical apparatus and components (e.g. thermocouples, photocells, strain gauges, junction boxes, switching devices), included in intrinsically-safe circuits of category "ib" not capable of storing or generating electrical power or energy in excess of limits stated in the relevant rules, and acceptable to the appropriate authority d) certified flameproof Ex(d) e) certified pressurised Ex(p) f) certified increased safety Ex(e) g) certified encapsulated Ex(m) h) certified sand filled Ex(q) i) certified specially Ex(s) j) cables sheathed with at least one of the following: • a non-metallic impervious sheath in combination with braiding or other metallic covering • copper or stainless steel sheath (for mineral insulated cables only)	Zone 1
2	Exhaust ventilation ducts	As stated under item 1.	Zone 1
3	<ul style="list-style-type: none"> • areas above a height of 450 mm from the deck • areas above a height of 450 mm from each platform for vehicles, if fitted, without openings of sufficient size permitting penetration of petrol gases downward • areas above platforms for vehicles, if fitted, with openings of sufficient size permitting penetration of petrol gases downward 	Electrical equipment complying with one of the following types of protection may be considered: a) any type that may be considered for zone 1 b) tested specially for zone 2 (e.g. type "n" protection) c) pressurised, and acceptable to the appropriate authority d) encapsulated, and acceptable to the appropriate authority e) the type which ensures the absence of sparks and arcs and of "hot spots" during its normal operation. For installation, in compliance with Pt C, Ch 4, Sec 13, [2.2.2], a minimum class of protection IP55 is acceptable as an alternative f) cables sheathed with at least a non-metallic external impervious sheath	Zone 2

Table 2 : Electrical equipment permitted in special category spaces below the bulkhead deck

No	Description of spaces	Electrical equipment	Hazardous area
1	Special category spaces	<p>Electrical equipment complying with one of the following types of protection may be considered:</p> <p>a) any type that may be considered for zone 0</p> <p>b) certified intrinsically safe apparatus Ex(ib)</p> <p>c) simple electrical apparatus and components (e.g. thermocouples, photocells, strain gauges, junction boxes, switching devices), included in intrinsically-safe circuits of category "ib" not capable of storing or generating electrical power or energy in excess of limits stated in the relevant rules, and acceptable to the appropriate authority</p> <p>d) certified flameproof Ex(d)</p> <p>e) certified pressurised Ex(p)</p> <p>f) certified increased safety Ex(e)</p> <p>g) certified encapsulated Ex(m)</p> <p>h) certified sand filled Ex(q)</p> <p>i) certified specially Ex(s)</p> <p>j) cables sheathed with at least one of the following:</p> <ul style="list-style-type: none"> • a non-metallic impervious sheath in combination with braiding or other metallic covering • copper or stainless steel sheath (for mineral insulated cables only) 	Zone 1
2	Exhaust ventilation ducts	As stated under item 1	Zone 1

3.4.2 A separate final sub-circuit is to be provided for each socket outlet. Each final sub-circuit is to be automatically disconnected in case of overcurrent, overload and earth fault (e.g. with an earth fault breaker).

3.4.3 Socket outlets with a current rating above 16A are to be provided with a switch. The switch is to be so interlocked that the plug can only be inserted or withdrawn when the switch is in "off" position.

3.4.4 The temperature rise on the live parts of socket outlets and plugs is not to exceed 30°C. Socket outlets and plugs are to be so constructed that they cannot readily short-circuited whether the plug is in or out, and so that a pin of the plug cannot be made to earth either pole of the socket outlet.

3.4.5 The minimum required degree of protection for socket outlets installed in vehicle spaces is IP56.

3.4.6 Socket-outlets and plugs with a specified degree of protection shall be provided with effective means to maintain the same degree of protection after the plug is removed from the socket-outlet.

Where a loose cover is used for this purpose, it shall be anchored to its socket-outlet, for example by means of a chain.

3.4.7 Suitable means for phase inversion are to be available for 3-phase sockets.

4 Type approved components

4.1

4.1.1 Accumulator lamps for the supplementary electric lighting, alarm systems for closing devices of openings and water leakage detection systems if of electronic type, and television surveillance systems are to be type approved or in accordance with [4.1.2].

4.1.2 Case-by-case approval based on submission of adequate documentation and execution of tests may also be granted at the discretion of the Society.

Part D

Service Notations

CHAPTER 13

SHIPS FOR DREDGING ACTIVITY

Section 1	General
Section 2	Hull and Stability
Section 3	Machinery and Dredging Systems
Appendix 1	Guidance on Calculation of Transverse Strength Hopper Well Structure

Section 1 General

1 General

1.1 Application

1.1.1 Ships complying with the requirements of this Chapter are eligible for the assignment of one of the following service notations:

- **dredger**
- **hopper dredger**
- **hopper unit**
- **split hopper dredger**
- **split hopper unit**

as defined in Pt A, Ch 1, Sec 2, [4.13].

1.1.2 Ships dealt with in this Chapter are to comply with:

- Part A of the Rules
- NR216 Materials and Welding
- applicable requirements according to Tab 1.

1.1.3 The additional service feature **EOC** may be assigned in accordance with Pt A, Ch 1, Sec 2, [4.13.1] only to:

- ships greater than 90m in length assigned the service notation **dredger**
- ships greater than 65m in length assigned the service notation **hopper dredger, hopper unit, split hopper dredger** or **split hopper unit**.

Table 1 : Applicable requirements

Item		Greater than or equal to 500 GT	Less than 500 GT
Ship arrangement		• Part B	• NR566
Hull	L ≥ 65 or 90 m (1)	• Part B • Ch 13, Sec 2	• Part B • Ch 13, Sec 2
	L < 65 or 90 m (1)	• NR600 • Ch 13, Sec 2	• NR600 • Ch 13, Sec 2
Stability		• Part B • Ch 13, Sec 2	• NR566 • Ch 13, Sec 2
Machinery and cargo systems		• Part C • Ch 13, Sec 3	• NR566 • Ch 13, Sec 3
Electrical installations		• Part C	• NR566
Automation		• Part C	• NR566
Fire protection, detection and extinction		• Part C	• NR566
<p>(1) 90 m for ships assigned with the service notation dredger and 65 m for ships assigned with the service notation hopper dredger, hopper unit, split hopper dredger and split hopper unit.</p> <p>Note 1: NR566: Hull Arrangement, Stability and Systems for Ships less than 500 GT. NR600: Hull Structure and Arrangement for the Classification of Cargo Ships less than 65 m and Non Cargo Ships less than 90 m.</p>			

1.2 Documents to be submitted

1.2.1 The document listed in Tab 2 are to be submitted for approval, as applicable.

1.2.2 The document listed in Tab 3 are to be submitted for information, as applicable.

1.2.3 The following documents are also to be submitted for **split hopper dredger** and **split hopper unit**:

- Superstructure hinges and connections to the ship’s structure, including mass and location of the superstructure centre of gravity
- Structure of hydraulic jack spaces
- Deck hinges, including location of centre of buoyancy and of centre of gravity of each half-hull, mass of equipped half-hull, half mass of spoil or water, supplies for each half-hull and mass of superstructures supported by each half-hull
- Hydraulic jacks and connections to ship’s structure including operating pressure and maximum pressure of the hydraulic jacks (cylinder and rod sides) and corresponding forces
- Longitudinal chocks of bottom and deck
- Transverse chocks
- Hydraulic installation of jacks, with explanatory note.

Table 2 : Documents to be submitted for approval

No.	Description of the document
1	Construction of suction inlet tube
2	Gantry foundations
3	Bottom door and cylinder integrations
4	Overflow
5	Calculation of clearances
6	Hinges, chocks and cylinder integrations
7	Integration of spuds
8	Couplings
9	Integration cutter ladder
10	Integration anchor booms
11	Foundation excavator
12	General arrangement of the dredging equipment
13	Specification of the dredging equipment operation test
14	Transverse sections through hoppers, wells, pump rooms and dredging machinery spaces
15	Structural arrangement of hoppers and supporting structures including when relevant: <ul style="list-style-type: none"> • location, mass, fore and aft extent of the movable dredging equipment, for each loading condition • calculations of the horizontal forces acting on the suction pipe and on the gallows
16	Closing arrangements, if any
17	Connection of dredging machinery with the hull structure

Table 3 : Documents to be submitted for information

No.	Description of the document
1	Calculation of SWBM and shear forces in sailing and working conditions
2	Design loads on all components of the dredging equipment

Section 2 Hull and Stability

Symbols

a	: Distance from the bottom to the sealing joint located at the lower part of the hopper well, in m
b_p	: Maximum breadth, in m, of the hopper well
C	: Wave coefficient, defined in Pt B, Ch 5, Sec 4
d	: Vertical distance, in m, from the calculation point to the filling level of the considered navigation or dredging situation (see [3.1.1])
g	: Gravity acceleration, in m/s^2 taken equal to $9,81 m/s^2$
H_{Di}	: Wave parameter corresponding to the dredging situation i (see [3.1.1])
h_{Di}	: Distance, in m, from spoil level to base line (see Fig 7) when working in the dredging situation i (see [3.1.1])
k	: Material factor for steel, defined in Pt B, Ch 4, Sec 1, [2.2]
l_p	: Maximum length, in m, of the hopper well
n	: Navigation coefficients, defined in Pt B, Ch 5, Sec 3, [1.1.2]
n_{Di}	: Navigation coefficient for the dredging situation i (see [3.1.1])
P_{Di}	: Mass, in t, of the spoil contained in the hopper space for the dredging situation i (see [3.1.1])
R_{eH}	: Minimum yield stress, in N/mm^2 , of the material
R_m	: Minimum ultimate tensile strength, in N/mm^2 , of the material.
R_y	: Minimum yield stress, in N/mm^2 , of the material, to be taken equal to $235/k N/mm^2$, unless otherwise specified
T_{Di}	: Design draught, in m, corresponding to the dredging situation i (see [3.1.1])
T_{IF}	: Navigation draught, in m, corresponding to the international freeboard
V_{Di}	: Volume of spoil contained in the hopper space for the dredging situation i (see [3.1.1]), in m^3 (vertically limited to the lowest overflow level)
δ	: Specific gravity of the mixture of sea water and spoil for the navigation situation, taken equal to 1,025
δ_i	: Specific gravity of the mixture of sea water and spoil for the dredging situation i (see [3.1.1]), taken equal to:
	$\delta_i = \frac{P_{Di}}{V_{Di}}$

1 Stability

1.1 Intact stability

1.1.1 General

The intact stability of the ship is to be sufficient to comply with the criteria indicated in [1.1.3] for the operational loading conditions of Pt B, Ch 3, App 2, [1.2.10] and the calculation method described in [1.1.2].

1.1.2 Calculation method

The calculation of the righting lever curves is to take into account:

- the change of trim due to heel
- the inflow of seawater or outflow of liquid cargo at the upper edge of the hopper coaming in the case of an open hopper
- the inflow of water at the lower edge of the overflow, located at cargo level or at the lowest possible position above cargo level, or at the lower edge of the lowest overflow ports or spillways.

1.1.3 Intact stability criteria

The area under the righting lever curve is not to be less than

- 0,07 m.rad up to an angle of 15° when the maximum righting lever GZ_{max} occurs at 15°
- 0,055 m.rad up to an angle of 30° when the maximum righting lever GZ_{max} occurs at 30° or above.

Where the maximum righting lever GZ_{max} occurs at angles of between 15° and 30° , the corresponding area under the righting lever curve is to be equal to or greater than A , where A is to be obtained, in m-rad by the following formula:

$$A = 0,055 + 0,001 (30^\circ - \theta_{max})$$

where

θ_{max} : angle of heel in degrees at which the righting lever curve reaches its maximum.

The area under the righting lever curve between:

- the angles of heel of 30° and 40°, or
- the angle of heel of 30° and the down-flooding angle θ_r , if this angle is less than 40°,

is to be not less than 0,03 m.rad.

The righting lever GZ is to be at least 0,20 m at an angle of heel equal to or greater than 30°.

The maximum righting lever GZ_{max} should occur at an angle of heel not less than 15°.

The initial metacentric height GM_0 as corrected for the free surface effect of the tanks and the hopper(s) containing liquids is not to be less than 0,15 m.

1.1.4 Weather criterion at the international freeboard

At the international freeboard, the dredger is to comply with the requirements of Pt B, Ch 3, Sec 2, [3.2] considering:

- the state of the cargo as a liquid
- 10% stores and fuel
- and the hopper(s) loaded with a homogeneous cargo up to the upper edge of the hopper coaming if the density of the cargo is not less than 1000 kg/m³; otherwise the hopper is considered to be partially loaded with a cargo of density equal to 1000 kg/m³.

1.1.5 Weather criterion at the dredging freeboard

At the dredging freeboard, the dredger is to comply with the requirements of Pt B, Ch 3, Sec 2, [3.2] considering a reduced wind pressure equal to 270 N/m² for the most severe of the loading conditions in Pt B, Ch 3, App 2, [1.2.10]. The most severe loading condition is defined as the loading condition where the area under the righting lever curve between 0° and 40° is the least.

1.1.6 Dredgers with open hopper(s)

When the height of the hopper coaming overflow edge above the dredging draught is less than the minimum bow height as specified in the International Load Line Convention 1966, the loading conditions in Pt B, Ch 3, App 2, [1.2.10] at the dredging draught are to take into account a layer of seawater on top of the cargo up to the overflow edge of the hopper coaming. However, if overflow ports or spillways of a size sufficient to enable a fast freeing of the water in the hopper on top of the cargo are fitted in the hopper coaming above the freeboard deck, the layer of sea water may be reduced up to the lower edge of the overflow ports or spillways.

The area of the overflow ports or spillways is to be at least equivalent to the area required by Regulation 24(1) of the International Convention on Load Lines, 1966.

1.1.7 Dredgers with bottom doors or similar means

Dredgers with bottom doors or similar means at port side and at starboard side are to comply with the following criteria considering an asymmetric discharging:

- the angle of equilibrium is not to exceed 25°
- the righting lever GZ within the 30° range beyond the angle of equilibrium is to be at least 0,10 m
- the range of stability is not to be less than 30°.

The dredger is assumed loaded up to the dredging draught with solid cargo of a density equal to 1900 kg/m³, when discharging, 20% of the total hopper load is assumed to be discharged only at one side of the longitudinal centreline of the hopper, horizontally equally distributed at the discharging side.

1.2 Damage stability where the additional class notation SDS has been requested

1.2.1 General

When the dredger is assigned a dredging freeboard which is less than B/2, where B is the statutory freeboard as calculated in accordance with the International Convention on Load Lines 1966, the dredger is to comply with the requirements of Pt B, Ch 3, App 3, [1], modified by [1.2.2], [1.2.3] and [1.2.5]. The dredger may not be assigned a freeboard less than B/3.

1.2.2 Calculation method of the righting lever curves

The calculation of the righting lever curves is to take into account:

- the change of trim due to heel
- the inflow of seawater or outflow of cargo at the upper edge of the hopper coaming in the case of an open hopper
- the inflow of water at the lower edge of the overflow, located at the highest possible position or at the lower edge of the lowest overflow ports or spillways
- the sliding of the cargo in the hopper, in transverse and longitudinal direction, according to the following shifting law:
 - for $\rho \leq 1400$ (liquid cargo):
 $\theta_r = \theta_g$
 - for $1400 < \rho < 2000$ (sliding cargo):
 $\theta_r = \theta_g (2000 - \rho) / 600$

- for $\rho \geq 2000$ (solid cargo):
 $\theta_r = 0$

where:

- ρ : Cargo density, in kg/m^3
- θ_r : Angle of heel or angle of trim, in degrees
- θ_g : Shifting angle of the cargo, in degrees.

1.2.3 Progressive flooding

Internal and external progressive floodings are to be considered in accordance with the requirements of Pt B, Ch 3, Sec 3, [3.3].

1.2.4 The attained subdivision index A_U

The attained subdivision index A_U is to be calculated for the draught d_U and the corresponding initial trim assuming the dredger in the unloaded condition, i.e. loaded with 50% fuel and stores, no cargo in the hopper(s) and the hopper(s) in direct communication with the sea.

1.2.5 The attained subdivision index A_L

The attained subdivision index A_L is to be calculated assuming the dredger loaded at the dredging draught d_l with 50% fuel and stores, for each of the densities ρ_d and ρ_i defined by:

- The design density ρ_d corresponding to the dredging draught and obtained from the following formula:

$$\rho_d = M_2 / V_2$$

where:

- M_2 : Mass of cargo in the hopper when the dredger is loaded at the dredging draught with 50% fuel and stores
- V_2 : Volume of the hopper at the highest overflow position.

- Each density ρ_i greater than ρ_d , obtained from the following formula:

$$\rho_i = 2200 - 200 i$$

where i is equal to 0; 1; 2; 3; etc.

The damage stability calculations are to be performed taking into account the initial trim of the dredging draught, an assumed permeability of the cargo in the hopper equal to 0% and a permeability of the space above the cargo equal to 100%.

1.2.6 Damage stability criteria

The dredger is to comply with the following criteria:

$$A \geq R$$

$$A_U \geq 0,7 R$$

$$A_L \geq 0,7 R$$

where:

- R : Required index as defined in Pt B, Ch 3, App 3, [1.3]
- A_U : Attained subdivision index at the unloaded draught d_U , as defined in [1.2.4]
- A_L : Attained subdivision index at the loaded draught d_l and for the cargo densities defined in [1.2.5].

2 Structure design principles

2.1 General

2.1.1 The attention of Designers is drawn to the fact that structural arrangement of ships for dredging activities involves discontinuities and that particular care is to be taken to avoid cracks or fractures.

2.1.2 Where dredgers are likely to work in association with hopper barges, the sheerstrake is to be protected, slightly below the deck, by a fender efficiently secured to the shell plating and extending over at least two thirds of the ship's length. Compensation is to be provided in way of the gangway port in raised deck, if fitted.

2.1.3 Where dredgers are likely to work in association with hopper barges, the shell plating is to be protected by a fender extending from the load waterline to the lowest waterline.

Additional structural reinforcements are to be provided in way of fenders and submitted to the Society for approval.

2.1.4 On bucket dredgers, in order to prevent dangerous flooding in the event of damage to the shell plating by metal debris (e.g. anchors), a watertight compartment is to be provided at the lower part of the caissons on either side of the bucket well in the area of the buckets. The compartment is to be of adequate size to allow surveys to be carried out.

2.1.5 Reinforcements are to be provided at locations where the hull is heavily stressed, such as:

- beneath the suction pipe gantries
- in way of the gantry frame on bucket dredgers
- points where tow ropes are secured
- connections of piles, etc.

2.1.6 Flat bottom areas, other than flat bottom area forward, where dynamic pressures due to the bottom impact might occur are to be examined by the Society on a case by case basis.

2.1.7 Overflows are to be provided in the hopper spaces. Their sectional area is to be large enough, taking into account the density of the water-spoil mixture to be drained off.

The disposition and location of the overflows are to be such that:

- they prevent the maximum authorised draught from being exceeded during loading
- trim and stability are always in accordance with the reviewed loading conditions
- draining off is made without any overflowing on the decks.

2.1.8 The corners of the cut-outs in the bottom plating are to be rounded and the radius is to be as large as possible, especially near the bottom doors.

The shape and the radius of cut-out corners are to be in accordance with Pt B, Ch 4, Sec 5 or NR600, Ch 2, Sec 1, as applicable.

2.1.9 Where hopper barges and suction dredgers are intended for unrestricted navigation, it is recommended, as far as possible, that sidescuttles are not be fitted in the shell plating.

2.1.10 The brackets are generally to be of a swept shape. A flange is to be fitted on the free edge if the length of this edge exceeds 60 times the web thickness.

2.1.11 For ships with one of the service notations **split hopper dredger** or **split hopper unit**, where panting beams are provided as stated in Pt B, Ch 11, Sec 1, [2.3.5], stringers and web frames are to be fitted on the centreline bulkheads of the two half-hulls to take up the reactions.

2.2 Longitudinal members in the area of the hopper well

2.2.1 The scantlings of the midship region are generally to be kept over the full length of the hopper well.

2.2.2 Attention is to be paid to the structural continuity of longitudinal members, especially coaming and hopper well bulkheads.

2.2.3 The upper deck stringer plate is to extend to the longitudinal bulkhead over the full length of the hopper well.

2.2.4 The fore and aft ends of longitudinal bulkheads of hopper spaces are to be extended by webs and brackets, with a size not less than one frame spacing (see Fig 1).

Openings in primary members in way of the transition are to be avoided.

A longitudinal effective coaming is to be extended via large brackets, the length of the bracket is to be equal to the height of the coaming. A suitable overlap between the coaming stay and bracket is to be provided. The bracket is to be full penetration welded to the deck.

2.2.5 The fore and aft ends of the centreline cellular keel are to be extended by means of brackets and webs. The sloped plating of the cellular keel is to be extended behind the hopper end bulkheads for at least one frame spacing.

In areas where a double bottom is provided, the brackets may be arranged in accordance with Fig 2.

2.2.6 The vertical sides of the trunks are to be extended beyond the end of the hopper spaces over a distance of at least 1,5 times their height.

2.2.7 The Society may, on a case-by-case basis, require that longitudinal members of the double bottom structure are extended, by means of brackets, inside the side compartments bounding the hopper spaces.

2.2.8 Arrangements other than those described in [2.2.4] to [2.2.7] are to be considered by the Society on a case-by-case basis.

Figure 1 : Longitudinal bulkhead extension outside of hopper spaces

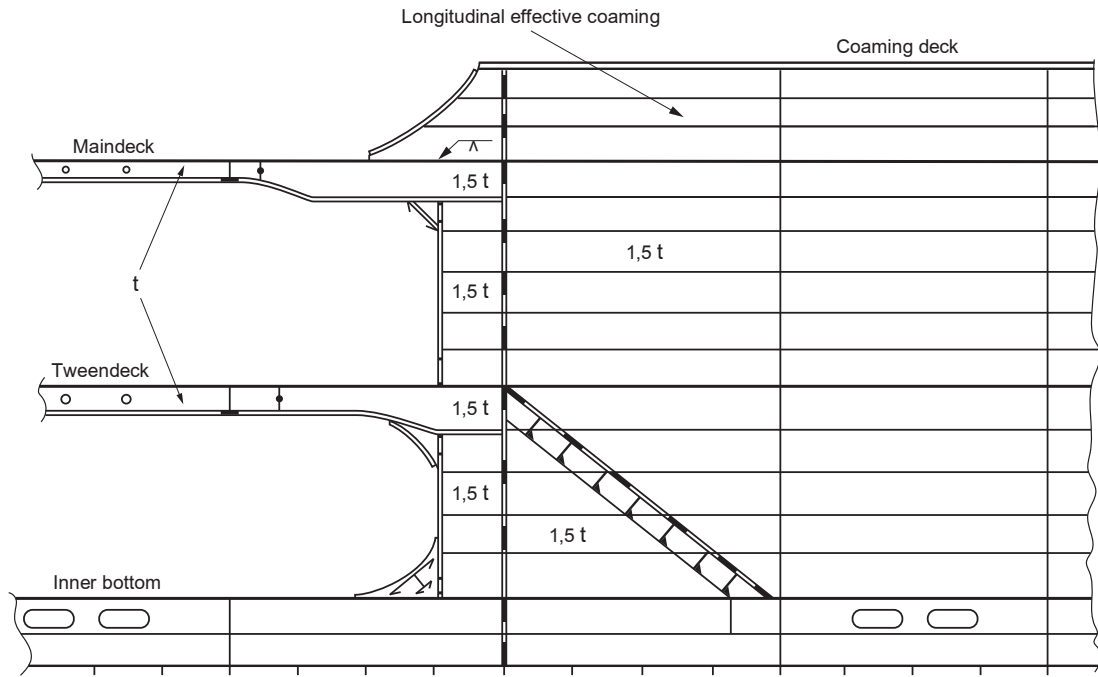
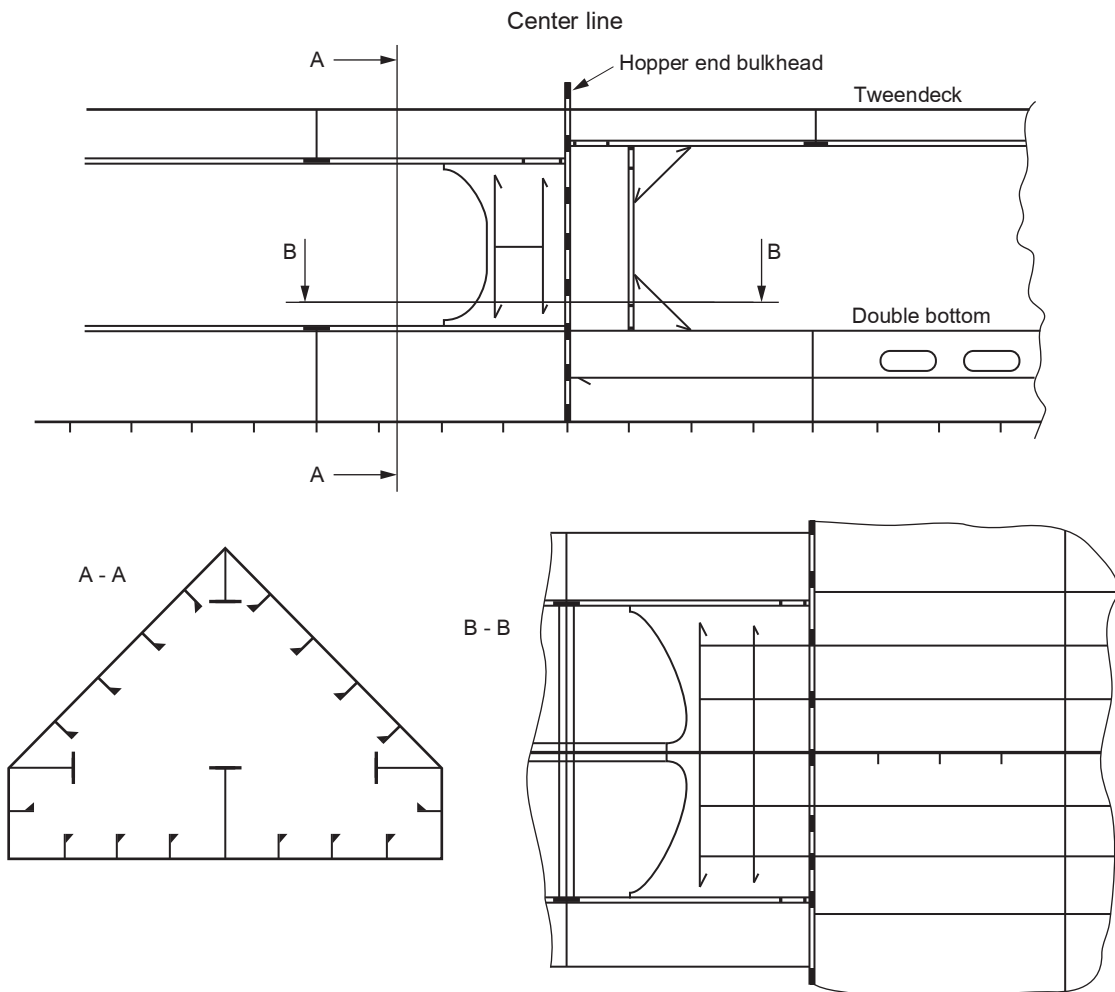

Figure 2 : Integration of cellular keels



2.3 Transverse members in the area of the hopper well

2.3.1 Transverse primary supporting rings

Within the hopper well area, transverse primary supporting rings are to be provided and are to involve:

- deep floors inside hopper spaces
- side vertical primary supporting members
- hopper well vertical primary supporting members
- strong beams inside hopper spaces, at deck or trunk level
- where necessary, cross-ties connecting either the side vertical primary supporting members to the hopper well vertical primary supporting members or the floor to the hopper well vertical primary supporting members.

The spacing of the transverse rings is generally to be taken not greater than five frame spaces.

2.3.2 The cellular keel is to be rigidly connected to the transverse rings required in [2.3.1].

2.3.3 The upper part of the cellular keel may be connected to the deck or trunk structure by means of axial or inclined pillars in association with strong beams, or by a centerline wash bulkhead.

2.3.4 The connection of hopper space floors with the longitudinal bulkheads and the cellular keel is to be arranged such that the continuity of the strength is ensured.

Where the floor is made of a box with sloping sides, particular attention is to be paid to the continuity of the lower flange. Fig 3 shows an example of possible connection.

Figure 3 : Example of connection with floor made of box with sloping sides

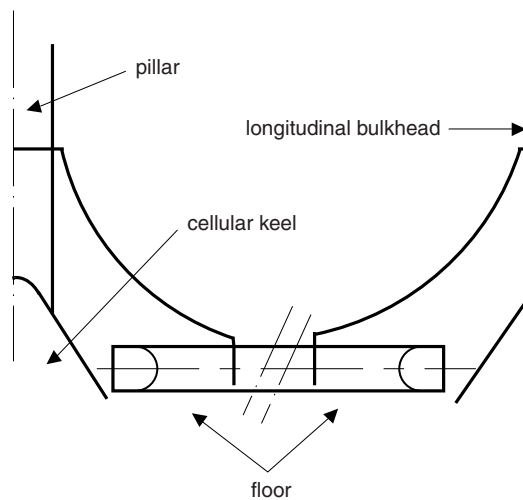

2.3.5 The connection between the flanges of the strong beams and the adjacent structure is generally to be made by means of brackets having the thickness of these flanges and extending inside the adjacent structure.

2.3.6 In general the sloped hopper well plating is to be supported by a deck or a stringer at the connection to the longitudinal vertical bulkhead. The welding at this location is to be full or partial penetration in the hopper well. Outside of the hopper well the welding may be fillet welding. Tensile stress in the fillet welds is to be less than $0,5 R_y$.

2.4 Arrangements relating to suction pipes

2.4.1 Where a cut-out is necessary in the side shell plating to fit the suction pipe guides, continuity of members is to be restored, for example by means of knuckled plates as thick as the side shell plating and with a knuckle angle as small as possible.

The knuckles are to be stiffened by reinforced vertical primary supporting members and intercostal girders of the same web height (see Fig 4 and Fig 5)

The fillet welding between the web of vertical primary supporting members and the knuckled plates is not to be made onto the knuckles, but about 50 mm apart.

Figure 4 : Suction pipe guide arrangement for transversally stiffened vessel

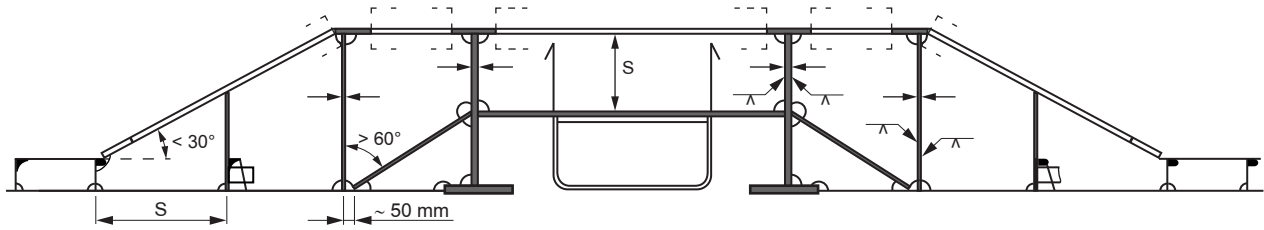
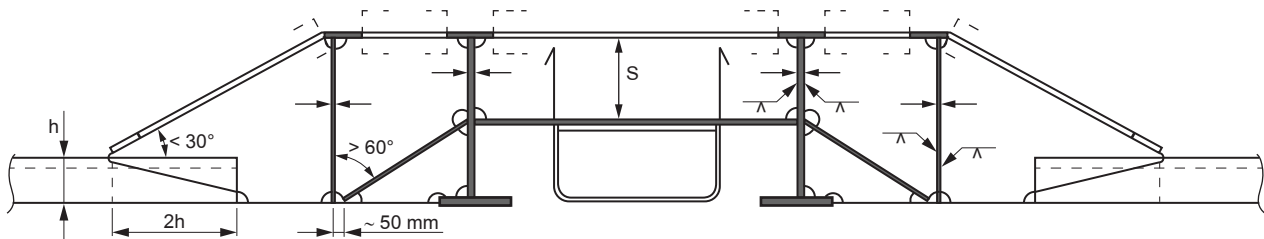

Figure 5 : Suction pipe guide arrangement for longitudinally stiffened



2.4.2 The suction pipe guides are to be fitted as far as possible from the hopper space ends or from any cut-out in the bottom or deck plating.

Deck plating is generally to be reinforced in way of suction pipe guides. Alternatively, strength of deck plating is to be justified by direct calculations for a knuckle angle greater than 30° on a case by case basis.

2.4.3 In areas where, during suction pipe operations, the drag head and the joint may run against the hull, one or several of the following arrangements are generally to be provided:

- thickness plating in excess of thickness obtained according to Pt B, Ch 7, Sec 4 or NR600, Ch 4, Sec 3, as applicable, for bilge and side shell
- reinforcement of the structure by means of vertical primary supporting members, girders, intermediate frames or longitudinals, depending on the construction type
- fenders to be provided outside the hull; these fenders together with the bilge shape are not to impede the suction pipe operation
- cofferdam to be provided to limit the possible flooding of side compartments.

2.4.4 The suction pipes are generally to be fitted with:

- auxiliary devices able to lift the suction pipe, in addition to the suction pipe gantries
- a sufficient number of attachment points on the suction pipe itself, to facilitate handling
- a load limiting device to avoid any overload, if the suction pipe is equipped with cutting teeth
- accessories fitted onto the suction pipe built in several parts to facilitate partial replacements in case of damage.

2.5 Areas subject to heavy wear

2.5.1 Some parts of the structure subjected to heavy wear, such as longitudinal bulkheads of hopper spaces, may be protected or reinforced to avoid frequent replacement.

2.5.2 If protection is provided by means of removable plates, called wear plates, attention is to be paid to avoid corrosion between the facing sides of these plates and the hopper space plating.

2.5.3 If reinforcement is made by increasing the thickness, the section moduli may be determined taking into account the extra thickness, provided it is not considered as a voluntary addition t_{vol_add} when applying requirements in Pt B, Ch 4, Sec 2.

If this extra thickness is disregarded in the section moduli calculation, it is to be considered as a voluntary addition t_{vol_add} when applying requirements in Pt B, Ch 4, Sec 2 and is to be clearly indicated on the midship section drawing.

2.6 Reinforcements for grounding

2.6.1 If grounding is considered for normal operation of the ship, the bottom plating and the bottom structure are to be reinforced as indicated in [2.6.2] to [2.6.5].

2.6.2 Along the full length of the ship, in the area of flat bottoms, the bottom net thickness obtained according to Pt B, Ch 7, Sec 4 or NR600, Ch 4, Sec 3, as applicable, is to be increased by 2,5 mm.

2.6.3 Where the ship has a transversely framed double bottom, floors are to be fitted at each frame space and associated with intercostal longitudinal girders, the mean spacing of which is to be not greater than 2,10 m.

Moreover, intercostal longitudinal ordinary stiffeners located at mid-spacing of bottom girders are to be provided.

2.6.4 Where the ship has a longitudinally framed double bottom, the floor spacing may not exceed three frame spaces and the bottom girder spacing may not exceed three longitudinal ordinary stiffener spaces.

Intercostal transverse stiffeners are to be provided at mid-span of longitudinal ordinary stiffeners.

Floors are to be stiffened by vertical stiffeners having the same spacing as the longitudinal ordinary stiffeners.

2.6.5 Where the ship is built with open hopper spaces (bottom doors provided on the bottom), reinforcements as required in [2.6.3] or [2.6.4] are to be provided within the side compartments, the cellular keel and, in general, within the limits of the flat bottom area.

2.7 Bolted structures

2.7.1 Where the dredger is made of several independent members connected by bolting, the connection is to be examined by the Society on a case-by-case basis.

3 Design loads

3.1 General

3.1.1 Design loads are to be determined for the various load cases in the following situations:

- navigation situation
- each dredging situation i , with i chosen between 1 to x , where x is the number of operating area notations which are assigned to the ship according to Pt A, Ch 1, Sec 2, [5.3.2].

The navigation situation is associated with the following design parameters:

- Navigation draught T_{IF} , in m, corresponding to the international freeboard
- block coefficient at the considered loading condition C_{B-LC}
- waterplane coefficient at the considered loading condition C_{W-LC}
- wave parameter H
- navigation coefficient n
- roll radius k_r and metacentric height GM as per full load condition
- the hopper space(s) filled with water up to the load line

Each dredging situation i is associated with the following design parameters:

- design draughts T_{Di} in m

For ships assigned the service notation **split hopper dredger** or **split hopper unit**, the following design draughts have to be included, as a minimum, among the different design dredging draughts:

T_{IF} : Draught when dredging at the international freeboard

T_{WL} : Draught when dredging with well filled up to waterline

T_{OL} : Draught when dredging with well filled with water up to the lowest overflow level

- still water bending moments and shear forces
- block coefficient at the considered loading condition C_{B-LC}
- waterplane coefficient at the considered loading condition C_{W-LC}
- wave parameter H_{Di} , calculated using the coefficients given in:
 - Tab 1 for ships assigned the operating area notation **unrestricted dredging area (T= x m)**,
 - Tab 2 for ships assigned the operating area notations defined in Pt A, Ch 1, Sec 2, Tab 3,
 - Tab 3 for ships assigned the additional service feature **EOC**, and granted with the operating area notations defined in Pt A, Ch 1, Sec 2, Tab 4

instead of the coefficients given for H , as defined in Pt B, Ch 5, Sec 3, [1.1.1]

- navigation coefficient n_{Di} , calculated using H_{Di} instead of H , as defined in Pt B, Ch 5, Sec 3, [1.1.2],
- Roll radius k_r and metacentric height GM as per full load condition
- spoil density δ_i and hopper space filling level h_{Di} .

For ships assigned the additional class notation **split hopper dredger** or **split hopper unit**, the following values of h_{Di} have to be included, as a minimum:

h_{IF} : Distance, in m, from spoil level to base line when dredging at the international freeboard (see Fig 7)

h_{WL} : Distance, in m, from spoil level to base line when dredging with well filled up to waterline (see Fig 7)

h_{OL} : Distance, in m, from the lowest overflow level to base line when dredging with well filled with water up to the lowest overflow level.

3.1.2 For dredgers made of bolted structure, the Society may require the hull girder loads calculated with the maximum length of the unit when mounted to be applied to each individual element.

Table 1 : Wave parameter H_{Di} coefficients for ships assigned the operating area notation unrestricted dredging area ($T= x m$)

Operating area notation	Assessment	A_0	A_1	e_1	A_2	e_2	L_c	h_{lu} (1)
unrestricted dredging area ($T= x m$)	Strength	1,00	1,50	2,20	0,45	1,70	486	–
	Fatigue	0,16	1,66	1,96	0,49	1,43	243	12,5

Note 1: ($T= x m$) indicates the maximum allowable draught x , in m, corresponding to the values of T_{Di} defined in [3.1.1]
Note 2: The operations area notation **unrestricted dredging area ($T= x m$)** is equivalent to the navigation notation **unrestricted navigation** when applying requirements of Part B.
(1) Reference height for loading/unloading fatigue assessment, in m, to be considered for the calculation of f_{plu} according to Pt B, Ch 5, Sec 3

Table 2 : Wave parameter H_{Di} coefficients for ships not assigned the additional service feature EOC

Ship length	Operating area notation	Assessment	A_0	A_1	e_1	A_2	e_2	L_c	h_{lu} (1)
≤ 110 m	dredging ≤ 8 miles from shore or $H_s \leq 1,5 m$ ($T= x m$)	Strength	0,21	1,27	2,38	0,31	1,69	223	–
		Fatigue	0,09	1,96	2,13	0,38	1,14	143	2,5
	dredging ≤ 15 miles from shore or $H_s \leq 2,5 m$ ($T= x m$)	Strength	0,46	1,44	2,46	0,37	1,79	308	–
		Fatigue	0,15	1,71	1,98	0,47	1,38	219	5,5
> 110 m and ≤ 150 m	dredging ≤ 8 miles from shore or $H_s \leq 2,0 m$ ($T= x m$)	Strength	0,25	1,29	2,38	0,32	1,71	239	–
		Fatigue	0,10	1,90	2,10	0,38	1,20	158	3,0
	dredging ≤ 15 miles from shore or $H_s \leq 3,0 m$ ($T= x m$)	Strength	0,49	1,48	2,46	0,39	1,75	321	–
		Fatigue	0,15	1,70	1,97	0,49	1,40	226	6,0
> 150 m	dredging ≤ 8 miles from shore or $H_s \leq 2,0 m$ ($T= x m$)	Strength	0,25	1,29	2,38	0,32	1,71	239	–
		Fatigue	0,10	1,90	2,10	0,38	1,20	158	3,0
	dredging ≤ 15 miles from shore or $H_s \leq 3,5 m$ ($T= x m$)	Strength	0,53	1,48	2,45	0,39	1,76	331	–
		Fatigue	0,16	1,69	1,96	0,49	1,41	230	6,5

Note 1: H_s : Maximum significant wave height, in m, associated to the operating area notation.
Note 2: ($T= x m$) indicates the maximum allowable draught x , in m, corresponding to the values of T_{Di} defined in [3.1.1]
(1) Reference height for loading/unloading fatigue assessment, in m, to be considered for the calculation of f_{plu} according to Pt B, Ch 5, Sec 3

Table 3 : Wave parameter H_{Di} coefficients for ships assigned the additional service feature EOC

Operating area notation	Assessment	A_0	A_1	e_1	A_2	e_2	L_c	h_{lu} (1)
dredging ≤ 8 miles from shore or $H_s \leq 1,0 m$ ($T= x m$)	Strength	0,07	1,28	2,45	0,3	1,59	161	–
	Fatigue	0,03	2,19	2,18	0,37	0,97	106	1,0
dredging ≤ 8 miles from shore or $H_s \leq 1,5 m$ ($T= x m$)	Strength	0,12	1,29	2,42	0,31	1,64	186	–
	Fatigue	0,05	2,11	2,17	0,37	1,03	116	1,5
dredging ≤ 8 miles from shore or $H_s \leq 2,0 m$ ($T= x m$)	Strength	0,16	1,27	2,42	0,3	1,65	206	–
	Fatigue	0,07	2,04	2,15	0,37	1,08	129	2,0
dredging ≤ 8 miles from shore or $H_s \leq 2,5 m$ ($T= x m$)	Strength	0,21	1,27	2,38	0,31	1,69	223	–
	Fatigue	0,09	1,96	2,13	0,38	1,14	143	2,5
dredging ≤ 8 miles from shore or $H_s \leq 3,0 m$ ($T= x m$)	Strength	0,25	1,29	2,38	0,32	1,71	239	–
	Fatigue	0,1	1,90	2,10	0,38	1,20	158	3,0

Note 1: H_s : Maximum significant wave height, in m, associated to the operating area notation.
Note 2: ($T= x m$) indicates the maximum allowable draught x , in m, corresponding to the values of T_{Di} defined in [3.1.1]
(1) Reference height for loading/unloading fatigue assessment, in m, to be considered for the calculation of f_{plu} according to Pt B, Ch 5, Sec 3.

Operating area notation	Assessment	A ₀	A ₁	e ₁	A ₂	e ₂	L _c	h _{lu} (1)
dredging ≤ 8 miles from shore or H_s ≤ 3,5 m (T= x m)	Strength	0,29	1,34	2,41	0,33	1,71	255	–
	Fatigue	0,12	1,84	2,07	0,40	1,25	173	3,5
dredging ≤ 15 miles from shore or H_s ≤ 2,5 m (T= x m)	Strength	0,33	1,35	2,41	0,33	1,78	267	–
	Fatigue	0,13	1,80	2,05	0,41	1,29	187	4,0
dredging ≤ 15 miles from shore or H_s ≤ 3,0 m (T= x m)	Strength	0,38	1,4	2,45	0,35	1,78	284	–
	Fatigue	0,13	1,76	2,02	0,44	1,33	200	4,5
dredging ≤ 15 miles from shore or H_s ≤ 3,5 m (T= x m)	Strength	0,42	1,44	2,45	0,37	1,75	296	–
	Fatigue	0,14	1,73	2,00	0,46	1,36	210	5,0
dredging ≤ 15 miles from shore or H_s ≤ 4,0 m (T= x m)	Strength	0,46	1,44	2,46	0,37	1,79	308	–
	Fatigue	0,15	1,71	1,98	0,47	1,38	219	5,5
dredging ≤ 15 miles from shore or H_s ≤ 4,5 m (T= x m)	Strength	0,49	1,48	2,46	0,39	1,75	321	–
	Fatigue	0,15	1,70	1,97	0,49	1,40	226	6,0
dredging ≤ 15 miles from shore or H_s ≤ 5,0 m (T= x m)	Strength	0,53	1,48	2,45	0,39	1,76	331	–
	Fatigue	0,16	1,69	1,96	0,49	1,41	231	6,5

Note 1: H_s : Maximum significant wave height, in m, associated to the operating area notation.
Note 2: (T= x m) indicates the maximum allowable draught x, in m, corresponding to the values of T_{Di} defined in [3.1.1]
(1) Reference height for loading/unloading fatigue assessment, in m, to be considered for the calculation of f_{plu} according to Pt B, Ch 5, Sec 3.

3.2 Loading conditions

3.2.1 In addition to the requirements in Pt B, Ch 5, Sec 4, as applicable, still water hull girder loads are to be calculated for the following loading conditions:

- homogeneous loading at maximum dredging draught if higher than the maximum service draught
- partial loading conditions
- any specified non-homogeneous loading condition, in particular where dredgers are fitted with several hopper spaces
- hopper space(s) filled with water up to the load line
- hopper space(s) filled with spoil at a draught corresponding to the international freeboard
- ballast navigation conditions, with empty hopper space(s), if applicable.

Calculation of the still water bending moment and shear force for any loading case corresponding to a special use of the ship may be required by the Society on a case-by-case basis. In particular, in the case of stationary dredgers, the still water bending moment distribution, where the suction pipe is horizontal, is to be submitted to the Society for approval.

3.3 Hull girder loads for dredgers, hopper dredgers and hopper units of more than 65 m in length

3.3.1 Application

The provisions in [3.3.2] to [3.3.5] apply to ships with one of the service notations **dredger**, **hopper dredger** or **hopper unit** of more than 65 m in length.

3.3.2 Vertical still water bending moments

In addition to the vertical still water bending moments M_{sw-max} and M_{sw-min} in navigation situation (see [3.1.1]) defined in Pt B, Ch 5, Sec 4, [2.2], the vertical still water bending moments in any of the dredging situations (see [3.1.1]) are also to be considered. The same value, provided by the designer for each dredging situation is to be given to both M_{sw-max,Di} and M_{sw-min,Di} associated respectively to hogging and sagging conditions.

If the design vertical still water bending moments in dredging situations are not defined at a preliminary design stage, at any hull transverse section, M_{sw-max,Di} and M_{sw-min,Di} in kN.m may be taken as:

$$M_{sw-max,Di} = f_{sw} \left(190 \cdot \frac{1+n}{2} \cdot C \cdot L^2 \cdot B(C_B + 0,7) \cdot 10^{-3} - M_{wv-h-mid,Di} \right)$$

$$M_{sw-min,Di} = -f_{sw} \left(190 \cdot \frac{1+n}{2} \cdot C \cdot L^2 \cdot B(C_B + 0,7) \cdot 10^{-3} + M_{wv-s-mid,Di} \right)$$

where:

f_{sw} : Distribution factor along the ship length to be taken:

- equal to 1 from 0,35L to 0,65L and to 0 at the ship's ends for hopper dredgers with single hopper well. Intermediate values are to be obtained by linear interpolation
- as defined in Pt B, Ch 5, Sec 4, [2.2.3] for other cases

$M_{wv-h,mid,Di}$: Vertical wave bending moment for strength assessment in the dredging situation i (see [3.1.1]), in hogging conditions, defined in [3.3.3] where $F_M = 1$

$M_{wv-s,mid,Di}$: Vertical wave bending moment for strength assessment in the dredging situation i (see [3.1.1]), in sagging conditions, defined in [3.3.3] where $F_M = 1$

3.3.3 Vertical wave bending moments

In addition to the vertical wave bending moments M_{wv-h} and M_{wv-s} in navigation situation (see [3.1.1]) defined in Pt B, Ch 5, Sec 4, [3.1], the vertical wave bending moments in any of the dredging situations (see [3.1.1]) at any hull transverse section, $M_{wv-h,Di}$ and $M_{wv-s,Di}$ are to be obtained using definitions in Pt B, Ch 5, Sec 4, [3.1], replacing n by n_{Di} or H by H_{Di} .

3.3.4 Horizontal wave bending moments

In addition to the horizontal wave bending moment M_{wh} in navigation situation (see [3.1.1]) defined in Pt B, Ch 5, Sec 4, [3.3], the horizontal wave bending moments in any of the dredging situations (see [3.1.1]), $M_{wh,Di}$ at any hull transverse section is to be obtained using definition in Pt B, Ch 5, Sec 4, [3.3], replacing H by H_{Di} .

3.3.5 Vertical wave shear forces

In addition to the vertical wave shear forces Q_{wv-pos} and Q_{wv-neg} in navigation situation (see [3.1.1]) defined in Pt B, Ch 5, Sec 4, [3.2], the vertical wave shear forces in any of the dredging situations (see [3.1.1]) at any hull transverse section $Q_{wv-pos,Di}$ and $Q_{wv-neg,Di}$ are to be obtained using definitions in Pt B, Ch 5, Sec 4, [3.2.1], replacing n by n_{Di} .

3.4 Hull girder loads for split hopper dredgers and split hopper units of more than 65 m in length

3.4.1 Application

The provisions in [3.4.2] to [3.4.8] apply to ships with one of the service notations **split hopper dredger** or **split hopper unit** of more than 65 m in length.

3.4.2 General

Horizontal bending moments are to be calculated assuming that the hopper well is simply supported at each end.

The clearance between the two half-hulls is to be large enough not to be suppressed when the hopper well is full up.

Details of the calculation of the necessary clearances are to be submitted to the Society for review.

However, the horizontal bending moments are generally to be calculated assuming that both ends of the hopper well are partly clamped, on condition that at deck and bottom level chocks are provided forward and aft of the well so that:

- the clearance between the two half-hulls is nil
- the chocks are long enough to withstand the end moments due to the horizontal forces developed along the hopper well.

3.4.3 Vertical still water bending moments

The vertical still water bending moments to be applied on one half-hull in navigation and dredging situations are to be taken equal respectively to half the vertical still water bending moments defined in [3.3.2].

3.4.4 Vertical wave bending moments

The vertical wave bending moments to be applied on one half-hull in navigation and dredging situations are to be taken equal respectively to half the vertical wave bending moments defined in [3.3.3]

3.4.5 Horizontal still water bending moments

The horizontal still water bending moments to be applied on one half-hull in navigation and dredging situations are to be obtained, in kN.m, from the formulae given in Tab 4, assuming that the hopper well is simply supported at each end.

If the hopper well may not be considered as simply supported at each end, the horizontal still water bending moments to be applied on one half-hull in navigation and dredging situations are to be determined on a case by case basis.

Table 4 : Split hopper dredgers and split hopper units - Horizontal still water bending moment on half-hulls

	M_{sh-hh} , in kN.m	
	for portside half-hull:	for starboard half-hull:
Hopper well mid-section (1)	$\left(\frac{1}{8} + \frac{c_1}{2l_p}\right) p l_p^2$	$-\left(\frac{1}{8} + \frac{c_1}{2l_p}\right) p l_p^2$
Hopper well ends (1)	0	
(1) Between hopper well mid-section and ends, the value of the horizontal still water bending moment is to be obtained by linear interpolation.		
Note 1:		
p	: Load per metre, in kN/m, applied along the hopper well, defined in Tab 5 depending on the loading condition	
c_1	: Distance, in m, from deck hinges to ends of hopper well (see Fig 6).	

Figure 6 : Definitions of dimensions in hopper well area

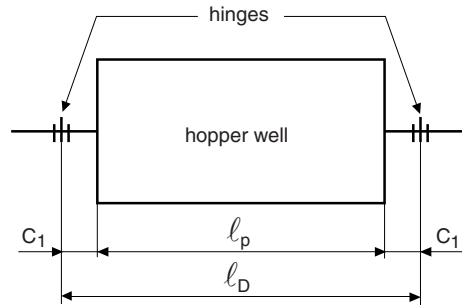
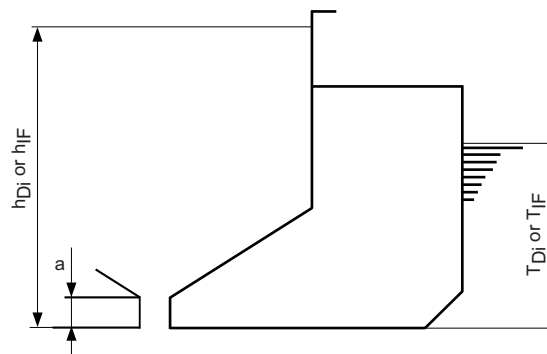

Table 5 : Load per metre applied along the hopper well

Loading condition	p , in kN/m
Navigation situation	0
Dredging with spoil loading corresponding to the international freeboard	$\frac{\delta_i(h_{IF} - a)^2 - 1,025(T_{IF} - a)^2}{2} g$
Dredging condition with well filled with water up to the waterline	0
Dredging condition with well filled with water up to the lowest weir level	$\frac{,025[(h_{OL} - a)^2 - (T_{OL} - a)^2]}{2} \xi$
Other dredging situations	$\frac{\delta_i(h_{Di} - a)^2 - 1,025(T_{Di} - a)^2}{2} g$
Note 1: See Fig 7 for the definitions of distances for calculation of the loads applied along the hopper well	

Figure 7 : Definitions of distances for calculation of the load applied along the hopper well



3.4.6 Horizontal wave bending moments

The horizontal wave bending moments to be applied on one half-hull in navigation and dredging situations are to be obtained, in kN.m, from the formulae given in Tab 6, assuming that the hopper well is simply supported at each end.

If the hopper well may not be considered as simply supported at each end, the horizontal still water bending moments to be applied on one half-hull in navigation and dredging situations are to be determined on a case by case basis.

Table 6 : Split hopper dredgers and split hopper units - Horizontal wave bending moment on half-hulls

	M_{wh-hh} , in kN.m	
	Navigation situation	Dredging situations
Hopper well mid-section (1)	$\left[T_{IF} + 0,079Cn \left(2 \frac{\ell_D}{L} - 1 \right) (C_{B-LC} + 0,7) \right] \frac{M_{wv}}{B}$	$\left[T_{Di} + 0,079Cn_{Di} \left(2 \frac{\ell_D}{L} - 1 \right) (C_{B-LC} + 0,7) \right] \frac{M_{wv}}{B}$
Hopper well ends (1)	0	

(1) Between hopper well mid-section and ends, the value of the horizontal wave bending moment is to be obtained by linear interpolation.
Note 1: M_{wv} : Vertical wave bending moment, in kN.m, in navigation or dredging situations, as applicable, in hogging or sagging conditions, as defined in [3.3.3].

3.4.7 Combined still water and wave vertical bending moment

In the midship area, the total vertical bending moment M_v to be applied on half-hull is to be obtained, in kN.m, from Tab 7.

At hopper well ends, the total bending moment M_v is to be determined in accordance with Tab 7 considering:

- for the still water vertical bending moment: the greater of the values at the fore and aft hopper well ends
- for the vertical wave bending moment: the longitudinal distribution defined in Pt B, Ch 5, Sec 4, Fig 2.

Table 7 : Vertical bending moment applied on half-hull

Condition	Vertical bending moment M_v , in kN.m	
	Navigation situation	Dredging situation i
Hogging	$\frac{M_{sw-max} + M_{wv-h}}{2}$	$\frac{M_{sw-max,Di} + M_{wv-h,Di}}{2}$
Sagging	$\frac{M_{sw-min} + M_{wv-s}}{2}$	$\frac{M_{sw-min,Di} + M_{wv-s,Di}}{2}$

Note 1:

M_{sw-max}, M_{sw-min} : Maximum and minimum still water vertical bending moment in navigation situation as defined in Pt B, Ch 5, Sec 4, [2.2]

M_{wv-h}, M_{wv-s} : Wave vertical bending moment in navigation situation in hogging and sagging condition, respectively, defined in Pt B, Ch 5, Sec 4, [3.1]

$M_{sw-max, Di}, M_{sw-min, Di}$: Maximum and minimum still water vertical bending moment in the dredging situation i, as defined in [3.3.2]

$M_{wv-h, Di}, M_{wv-s, Di}$: Wave vertical bending moment in the dredging situation i, in hogging and sagging condition, respectively, defined in [3.3.3].

3.4.8 Combined still water and wave horizontal bending moment

The total horizontal bending moment M_H applied on half-hull at hopper well mid-section and at hopper well ends, in navigation and dredging situations, is to be obtained, in kN.m, from the following formula:

$$M_H = M_{sh-hh} + M_{wh-hh}$$

where:

M_{sh-hh} : Horizontal still water bending moment, defined in [3.4.5] at hopper well mid-section and at hopper well ends, in navigation and dredging situations

M_{wh-hh} : Horizontal wave bending moment, defined in [3.4.6] at hopper well mid-section and at hopper well ends, in navigation and dredging situations.

3.4.9 Combined still water and wave vertical shear forces

The combined still water and wave vertical shear forces may be taken as equally distributed between both half hulls.

3.5 Internal pressures in hopper well

3.5.1 Pressures for the strength and fatigue assessments in navigation and dredging situations

The internal pressure P_{in} due to the mixture of sea water and spoil acting on any load point of the hopper boundary, in kN/m², is to be taken as:

$$P_{in} = P_s + P_w$$

where:

P_s : Static pressure due to water and spoil in hopper, as defined in [3.5.2]

P_w : Dynamic pressure due to water and spoil in hopper, as defined in [3.5.3]

3.5.2 Still water pressure in hopper well

The still water pressure P_S in the hopper well, in kN/m^2 , is to be taken as follows:

$$P_S = g \delta_i K_D d$$

without being taken less than:

- 12 kN/m^2 for prescriptive strength assessment
- 0 kN/m^2 for direct strength analysis and fatigue assessment

where:

- δ_i : density, taken equal to:
- for the navigation situation (see [3.1.1]): δ
 - for each of dredging situation i (see [3.1.1]): δ_i
- K_D : coefficient taken equal to:
- for the navigation situation:
 $K_D = 1,0$
 - for each of dredging situation i :
 $K_D = \cos^2\alpha + \phi \sin^2\alpha$
where:
 ϕ : friction coefficient, taken equal to:
 - for $\delta_i < 1,4$:
 $\phi = 1,0$
 - for $\delta_i \geq 1,4$:
 $\phi = 1,4/\delta_i$
- α : angle between the considered panel and horizontal plane

3.5.3 Inertial pressure in hopper well

The dynamic pressure P_{Wi} in the hopper well, in kN/m^2 , is to be taken as follows:

- for the navigation situation:
 $P_W = \delta [a_x (x_0 - x) + a_y (y_0 - y) + a_z (z_0 - z)]$
- for each of the dredging situations i :

$$P_{Wi} = \delta_i \left(\frac{a_x(x_G - x) + a_y(y_G - y)}{4} + a_z d K_D \right)$$

without being taken less than:

- 12 kN/m^2 for prescriptive strength assessment
- 0 kN/m^2 for direct strength analysis and fatigue assessment

where:

- x_0 : X coordinate, in m, of the reference point.
 y_0 : Y coordinate, in m, of the reference point.
 z_0 : Z coordinate, in m, of the reference point.

The reference point is to be taken as the point with the highest value of V_j , calculated for all the points that define the free spoil surface at the filling level of the considered navigation or dredging situation, as follows:

$$V_j = a_x (x_j - x_G) + a_y (y_j - y_G) + (a_z + g) (z_j - z_G)$$

where:

- x_j : X coordinate, in m, of the point j on the free spoil surface at the filling level of the considered navigation or dredging situation;
 y_j : Y coordinate, in m, of the point j on the free spoil surface at the filling level of the considered navigation or dredging situation;
 z_j : Z coordinate, in m, of the point j on the free spoil surface at the filling level of the considered navigation or dredging situation.
 x_G, y_G, z_G : X, Y and Z coordinates, in m, of the volumetric centre of gravity of spoil with respect to the reference coordinate system defined in Pt B, Ch 1, Sec 3, [2.6.1], to be taken as follows:
 - x_G, y_G : Volumetric centre of gravity of the hopper well
 - z_G : vertical position at mid height of the spoil, measured at the centerline. K_D : coefficient as defined in [3.5.2]

4 Hull girder strength of dredgers, hopper dredgers and hopper units

4.1 General

4.1.1 The hull girder strength of:

- ships of more than 90 m and assigned with the service notation **dredger**, and
- ships of more than 65 m and assigned with the service notation **hopper dredger** or **hopper unit**,

is to be checked for navigation situation and each of the dredging situations (see [3.1.1]) according to the criteria of Part B, Chapter 6, considering the still water and wave loads defined in [3.3].

4.1.2 For dredgers made of bolted structure, the Society may require the hull girder strength criteria to be applied to each individual element, considering the loads calculated according to [3.1.2].

4.2 Midship section modulus

4.2.1 In the determination of the midship section modulus according to Pt B, Ch 6, Sec 1, [1.4], account is to be taken of both 85% and 100% effectiveness of the sectional area of the cellular keel.

However the 85% and 100% effectiveness of the sectional area of the cellular keel may be replaced by the actual effectiveness of the cellular keel determined by a three dimensional finite element analysis.

4.2.2 Where cut-outs in the side shell are needed to fit the suction pipe guides, a section modulus calculation not taking account of the side shell plating may be required by the Society on a case-by-case basis, if the structural continuity is not correctly achieved.

5 Hull girder strength of split hopper dredgers and split hopper units

5.1 General

5.1.1 The yielding check of ships with one of the service notations **split hopper dredger** or **split hopper unit** and of more than 65 m in length is to be carried out for navigation situation and each of the dredging situations (see [3.1.1]) according to [5.2] to [5.4] considering:

- each half-hull as being subjected to independent bending
- the deck hinges and the hydraulic jacks acting as supports at the ends of the hopper well.

Both the vertical bending moment and horizontal bending moment acting within the well area are to be taken into account.

5.1.2 The hull section modulus, considered with the two half-hulls connected, is to be checked for navigation situation and each of the dredging situations (see [3.1.1]) according to the criteria of Pt B, Ch 6, Sec 1, [3], considering the still water and wave bending moments defined in [3.4]

See also [4.2] for the determination of the midship section modulus.

5.2 Definitions

5.2.1 Co-ordinate system

The hull girder strength is defined with reference to the following co-ordinate system, as shown in Fig 8:

- G : Centre of gravity of the half-hull transverse section
- GY : Transverse axis, parallel to Y defined in Pt B, Ch 1, Sec 3, [2.6] and crossing through G
- GZ : Vertical axis, parallel to Z defined in Pt B, Ch 1, Sec 3, [2.6] and crossing through G
- Gy, Gz : Main axes of the half-hull transverse section, defined in [5.2.2].

Figure 8 : Half-hull co-ordinate system

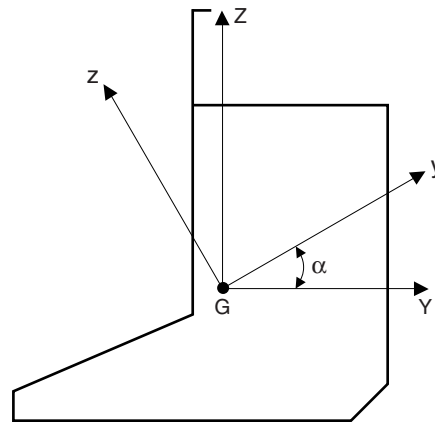

5.2.2 Main axes

The main axes Gy and Gz are obtained from the axes GY and GZ by a rotation around the centre of gravity G of an angle α obtained from the following formula:

$$\alpha = \frac{1}{2} \text{atan} \left(\frac{2I_{YZ}}{I_Z - I_Y} \right)$$

where:

- I_Y : Net moment of inertia, in m^4 , of the transverse section around the axis GY
- I_Z : Net moment of inertia, in m^4 , of the transverse section around the axis GZ
- I_{YZ} : Net inertia product, in m^4 , of the transverse section, in the reference (G, GY, GZ).

5.2.3 Bending moments

The bending moments M_y and M_z in relation to the main axes Gy and Gz, respectively, are to be obtained, in kN.m, from the following formulae:

$$M_y = M_V \cos \alpha + M_H \sin \alpha$$

$$M_z = -M_V \sin \alpha + M_H \cos \alpha$$

where:

- M_V : Vertical bending moment defined in [3.4.7], in kN.m, to be considered in hogging and sagging conditions, for the navigation and dredging situations
- M_H : Horizontal bending moment defined in [3.4.8], in kN.m, to be considered for the navigation and dredging situations
- α : Angle defined in [5.2.2].

As the main inertia axes of each half-hull are oblique, the bending of each half-hull is a deviated bending.

5.3 Hull girder stress

5.3.1 At any point of the transverse section of each half-hull, the hull girder normal stresses are to be obtained, in N/mm^2 , from the following formula:

$$\sigma_L = \left(z \frac{M_y}{I_{yM}} - y \frac{M_z}{I_{zM}} \right) 10^{-3}$$

where:

- M_y, M_z : Bending moments, in kN.m, in hogging and sagging conditions, for the navigation and dredging situations (see [3.1.1]), defined in [5.2.3]
- I_{yM}, I_{zM} : Net moments of inertia, in m^4 , of the transverse section around its main axes
- y, z : y and z coordinates, in m, of the calculation point with respect to the main axes Gy and Gz.

5.3.2 In the case of partly clamped ends of the hopper well (see [3.4.2]), the hull girder normal stresses are to be calculated in the hopper well mid-section and at hopper well ends.

In this case, the stresses are also to be calculated in the midship area assuming the ends supported as regards the horizontal moment. This calculation relates to the beginning of the hopper well drainage by opening of the two half-hulls.

5.3.3 In the case of supports at hopper well ends, the calculation of the hull girder normal stress is to be carried out in the hopper well mid-section.

5.3.4 For each section of calculation, the most unfavourable combination of moments is to be considered.

5.4 Checking criteria

5.4.1 It is to be checked that the normal stresses calculated according to [5.3.1] are in compliance with the requirements in Pt B, Ch 6, Sec 1, [3.5.2].

6 Hull scantlings

6.1 General

6.1.1 Hull scantlings are to be checked according to the applicable requirements of Part B, Chapter 7 for the additional design load sets defined in Tab 8.

Note 1: the design load sets SEA-Di are to be considered in addition to the design load set SEA-1 when applying the criteria for rounded bilge plating in Pt B, Ch 7, Sec 4, [6.2.1] item b).

For ships with one of the service notations **split hopper dredger** or **split hopper unit**, and of more than 65 m in length, the hull girder normal stresses to be used in the application of requirements of Part B, Chapter 7 are defined in [6.2].

Table 8 : Additional design load sets for dredgers

Item	Design load set	Load component	Draught	Acceptance criteria	Design load scenario / Loading condition
Outer shell and exposed deck	SEA-Di	P_{ex}, P_d	T_{Di}	AC-2	Sea-going / Dredging situation i
Hopper wells of dredgers	HW-N	$P_{in} - P_{ex}$ (1)	T_{IF}	AC-2	Seagoing / Navigation situation
	HW-Di	$P_{in} - P_{ex}$ (1)	T_{Di}	AC-2	Seagoing / Dredging situation i
Exposed deck, internal decks or platforms	DL-Di (2)	P_{dk}, F_U	T_{Di}	AC-2	Sea-going / Dredging situation i

(1) P_{ex} is to be considered for external shell only.
(2) Distributed or concentrated loads only. Need not be combined with simultaneously occurring green sea pressure.

6.2 Hull girder normal stress for split hopper dredgers and split hopper units of more than 65 m in length

6.2.1 The hull girder normal stress σ_L to be considered for the strength and buckling check of plating, stiffeners and primary supporting members according to Part B, Chapter 7 and Part B, Chapter 9 is to be obtained as calculated in [5.3].

6.3 Minimum net thicknesses of plating

6.3.1 The net thickness of plating is to be not less than the greater of the following values:

- 5 mm
- thickness, in mm, obtained from Tab 9.

Table 9 : Ships for dredging activities - Minimum net thicknesses of plating

Plating	Minimum net thickness, in mm
Hopper well <ul style="list-style-type: none"> • transverse and longitudinal bulkheads • cellular keel plating 	$2,7 + 0,034 L k^{1/2} + 0,0045 b$
Splash coaming	6

6.3.2 Where no protection is fitted on the deck areas where heavy items of dredging equipment may be stored for maintenance, the net thickness of the deck plating is to be not less than the value obtained, in mm, from the following formula:

$$t = 5,1 + 0,040 L k^{1/2} + 0,0045 b$$

6.4 Well bulkhead and cellular keel platings

6.4.1 The net thickness of the longitudinal bulkhead above the deck or within 0,1D below the deck is to be not less than the net thickness of the strength deck abreast of the hatchways.

6.4.2 The net thickness of the transverse and longitudinal bulkhead of a dredge pipe well is to be determined as for the side shell net thickness.

6.5 Transversely framed bottoms

6.5.1 Floors

The scantlings of floors located inside large compartments, such as pump rooms, are to be obtained from a direct calculation, according to Pt B, Ch 7, Sec 6 as applicable, and taking into account the following assumptions:

- floors are simply supported at ends
- local discontinuities in strength, due to the presence of wells, are to be considered.

7 Fatigue

7.1 General

7.1.1 Application

Loading and unloading fatigue assessment is to be performed according to the requirements of Pt B, Ch 10, Sec 1, [1.3] to all ships having a length equal to or greater than 150m or assigned with the additional service feature **EOC**, considering the requirements in [7.1.2] to [7.1.4].

7.1.2 Loading conditions

Loading conditions representative of the intended operation:

- navigation,
- ballast,
- dredging situation (see [3.1.1]),

and the fraction of time spent in each condition are to be considered for fatigue analysis.

Tanks filling levels associated to each loading condition are to be specified.

7.1.3 Still water loads for the fatigue assessment

The still water bending moment, M_{sw} , to be used for the fatigue assessment is to be taken:

- for the navigation and ballast conditions, as defined in Pt B, Ch 5, Sec 4, [2.1.3]
- for the dredging situations M_{sw} is to be taken equal to $1,00 M_{sw-min,Di}$.

7.1.4 List of special structural details

The following details are to be assessed in addition to those listed in Pt B, Ch 13, Sec 5:

- Corners of bottom door openings
- Crane rail details (e.g. expansion joints)
- Splash coaming details (e.g. expansion joints)
- Connections of the cellular keel to the transverse boxes and the hopper end bulkheads
- Connections of transverse boxes to the side structure
- Other details may be considered as special structural details whenever deemed necessary by the Society.

8 Hopper dredgers and hopper units: checking of hopper well structure

8.1 General

8.1.1 The requirements of Article [8] apply to ships with one of the service notations **hopper dredger** or **hopper unit**.

8.1.2 At the ends of the hopper spaces, the transverse bulkheads are to extend over the full breadth of the ship. Where this is not the case, web rings with special scantlings are to be provided.

8.2 Floors, webs, trunks, strongbeams and girders

8.2.1 Stresses in transverse primary members (such as floors, webs, trunks, strongbeams and girders) are to be obtained by a 2D or 3D beam model or FEM with the following assumptions:

- design loads as specified by the Designer
- load cases according to Pt B, Ch 5, Sec 2.

8.2.2 Stresses obtained according to [8.2.1] need to be combined with hull girder longitudinal stresses obtained according to Pt B, Ch 6, Sec 1, [2].

8.2.3 It is to be checked that stresses obtained according to [8.2.1] and [8.2.2] are not greater than the allowable stresses defined in Pt B, Ch 7, Sec 6, [5.1.4].

8.2.4 Alternatively, the transverse strength of the hopper well structure can be calculated considering the guidance provided in Ch 13, App 1.

9 Split hopper dredgers and split hopper units: superstructure hinges

9.1 General

9.1.1 For ships with one of the service notations **split hopper dredger** or **split hopper unit**, a check of the superstructure hinges according to [9.5] is to be carried out considering the forces defined in [9.4].

9.2 Arrangements

9.2.1 Chocks able to withstand the longitudinal forces induced by the superstructures are generally to be fitted on the deck located below the superstructures.

9.2.2 When the chocks are fitted on one side only, attention is to be paid to the longitudinal take over of forces by the hinges located on the side opposite to the chocks.

9.2.3 Chocks are to be able to work when the half-hulls swing apart to discharge the spoil.

9.2.4 Special attention is to be paid to the reinforcement below the deck in way of the hinges and chocks, as well as to the fixing of the hinge to the strength members of the superstructures.

The scantlings of these members are to be calculated considering the forces given in [9.4.3] applied at the level of the hinge pin.

9.2.5 Generally, no cut-out is to be fitted immediately near to hinges or chocks.

9.3 Materials used for the hinges

9.3.1 Grades of hull steel plates

In normal service conditions, the hull steel plates are to be of the grade defined in Tab 10.

Moreover, in low temperature service conditions, the choice of the steel grade is to be made with the Society on a case-by-case basis, according to the actual service conditions and to the design detail of the welded assembly.

Table 10 : Material grade requirements for superstructure hinges

Gross thickness, in mm	Normal strength steel	Higher strength steel
$t \leq 20$	A	AH
$20 < t \leq 25$	D	DH
$25 < t \leq 30$	E	DH
$t > 30$	E	EH

9.3.2 Grades of steel castings and steel forgings

The steel grade of the steel castings and steel forgings is to be defined according to the service temperature of the part and to the weld location on the part.

9.3.3 Grades of steel for hinge pins

The hinge pins are generally to be made of forged steel.

In addition to the rule checks defined in NR216 Materials and Welding, Chapter 5, a series of impact tests is to be carried out on three Charpy V test pieces and the minimum mean value of impact energy KVL is to be equal to or greater than 27 J at 0°C.

9.3.4 Inspections and tests of weld connections

For welds concerning the main members of the hinges, non-destructive examinations are to be carried out along the full length of the joint:

- for butt welds: 100% radiographic and ultrasonic examination
- for fillet welds with deep penetration: 100% ultrasonic examination and 100% magnetic particle inspection or penetrant fluid test
- for fillet welds with small penetration: 100% magnetic particle inspection or penetrant fluid tests.

9.4 Forces

9.4.1 The forces defined in [9.4.2] to [9.4.4] may be replaced by results from model tests or by representative calculations.

In such case, the method used and the assumed conditions for model tests or calculation are to be submitted to the Society for information.

9.4.2 The forces F_x , F_y and F_z , in kN, applied on superstructures in respectively x, y and z direction, are to be obtained as follows:

- for split hopper dredger/unit with a length $L < 65$ m:

$$F_x = 0 ; F_y = F_T ; F_z = F_Z + F_V$$

with F_T , F_Z and F_V to be calculated from the formulae in NR600, Ch 6, Sec 1, [13.4.4], item c), with M , in t, to be taken as the mass of the superstructures.

- for split hopper dredger/unit with a length $L \geq 65$ m:

F_x , F_y and F_z to be calculated from the applicable formulae of F_{u-d} , as defined in Pt B, Ch 5, Sec 6, [6.2.1] and Pt B, Ch 5, Sec 6, Tab 11 with m_{u-d} , in t, to be taken as the mass of the superstructures.

9.4.3 In the case of superstructures connected to the ship by means of two simple hinges and two hinges with connecting tie-rods (as shown in Fig 9 and Fig 10), the forces are to be obtained, in kN, from the following formulae:

- force in line with a tie-rod:

$$F = \frac{1}{\cos\beta} \left(\frac{1}{2} + \frac{\epsilon_L}{d_L} \right) \left[\left(\frac{1}{2} - \frac{\epsilon_T}{d_T} \right) F_Z + \frac{d_V}{d_T} F_V \right]$$

- vertical force in a simple hinge:

$$F = \left(\frac{1}{2} + \frac{\epsilon_L}{d_L} \right) \left[\left(\frac{1}{2} + \frac{\epsilon_T}{d_T} \right) F_Z + \frac{d_V}{d_T} F_V \right]$$

- transverse force in a hinge:

$$F = \left(\frac{1}{2} + \frac{\epsilon_L}{d_L} \right) \left[\left(\frac{1}{2} - \frac{\epsilon_T}{d_T} \right) F_Z \tan\beta + \left(1 - \frac{d_V}{d_T} \tan\beta \right) F_V \right]$$

- longitudinal force for each chock:

$$F = \frac{F_x}{n_B}$$

where:

β : Angle of tie-rods with respect to the vertical line, in degrees

d_T : Transverse distance between a simple hinge and a tie-rod hinge, in m

d_V : Vertical distance from the centre of gravity of the superstructures to the horizontal plane passing through the hinge centreline, in m

d_L : Longitudinal distance between the fore and aft hinges, in m

ϵ_T : Transverse eccentricity of the centre of gravity of the superstructures (taken as positive if the centre of gravity is on the side of the simple hinges, and as negative otherwise), in m

ϵ_L : Longitudinal eccentricity of the centre of gravity of the superstructures (positive), in m

n_B : Number of longitudinal chocks.

Where a longitudinal chock is provided on one side only, the hinges are to be able to withstand the longitudinal force F_x .

The distribution of forces in the case of other arrangements is to be examined by the Society on a case-by-case basis.

Figure 9 : Connection between superstructure and ship - Transverse direction

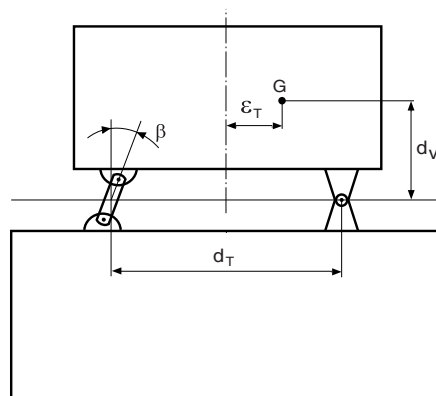
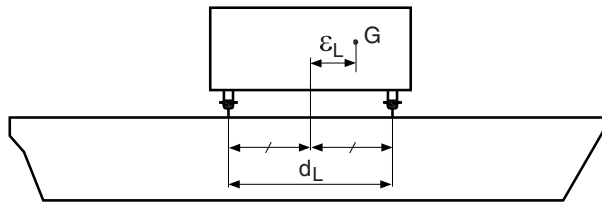

Figure 10 : Connection between superstructure and ship - Longitudinal direction



9.4.4 The force F to be considered for the check of the hinge scantlings is to be taken equal to:

- for a simple hinge:
the resultant of the horizontal and vertical forces
- for a hinge with tie-rod:
the force in the tie-rod centreline.

Moreover, the horizontal force in the hinges due to withstanding of the longitudinal force F_x in the case of a horizontal chock on one side only is to be considered alone.

9.5 Scantlings of the hinges

9.5.1 The hinges consist generally of two side straps and a centre eye connected by a pin, as shown in Fig 11.

The two main types of hinges are generally the following (see Tab 11):

- type I: welded assembly made of plates
- type II: welded assembly made of plates and of cast steel or forged steel parts.

The check of scantlings in [9.5.2] applies to the case of direct bearing of the pin on the side straps and the centre eye (see Fig 12) and to the case of load transfer by bearings (see Fig 13). In the second case, the designer is to demonstrate that the bearings can withstand the calculated forces.

Hinges whose manufacture is different from these two cases are to be examined by the Society on a case-by-case basis.

9.5.2 For the pins, centre eye and side straps of the hinges, the applied forces are to comply with the formulae given in Tab 12.

Figure 11 : Superstructure hinge arrangement

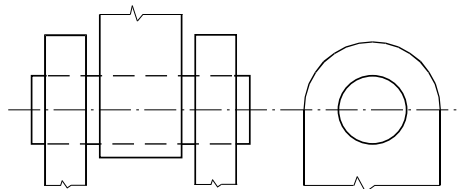

Table 11 : Type of hinges

Type I superstructure hinges	Type II superstructure hinges

Figure 12 : Superstructure hinges: case of direct bearing

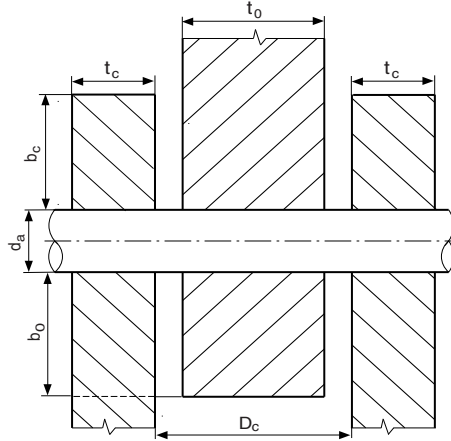

Figure 13 : Superstructure hinges: case of load transfer by bearings

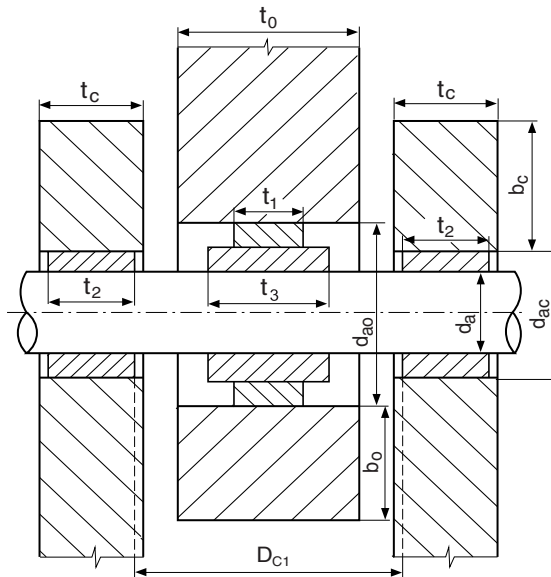

Table 12 : Scantling check of superstructures hinges

Case	Elements to be checked			
		Pins	Centre eye	Side straps
Direct bearing	$F < \frac{d_a^2 R_m}{5,76} 10^{-3}$ $F < \frac{2}{3} d_a t_0 R_{eH} 10^{-3}$	<ul style="list-style-type: none"> if $t_0 < d_a$: $F < \frac{d_a^3 R_m}{2D_C - t_0} 10^{-3}$ if $t_0 \geq d_a$: $F < \frac{d_a^3 R_m}{2D_C - 2t_0 + d_a} 10^{-3}$ 	$F < \frac{b_0 t_0 R_{eH}}{2,27} 10^{-3}$ $F < d_a t_0 R_{rad} 10^{-3}$	$F < \frac{b_c t_c R_{eH}}{1,14} 10^{-3}$ $F < 2 d_a t_c R_{rad} 10^{-3}$
Load transfer by bearings	$F < \frac{d_a^2 R_m}{5,76} 10^{-3}$ $F < \frac{2}{3} d_a t_3 R_{eH} 10^{-3}$	<ul style="list-style-type: none"> if $t_3 < d_a$: $F < \frac{d_a^3 R_m}{2D_{C1} - t_3} 10^{-3}$ if $t_3 \geq d_a$: $F < \frac{d_a^3 R_m}{2D_{C1} - 2t_3 + d_a} 10^{-3}$ 	$F < \frac{b_0 t_0 R_{eH}}{2,27} 10^{-3}$ $F < \frac{2}{3} d_{a0} t_1 R_{eH} 10^{-3}$	$F < \frac{b_c t_c R_{eH}}{1,14} 10^{-3}$ $F < \frac{4}{3} d_{ac} t_2 R_{eH} 10^{-3}$

Note 1:
 R_{rad} : Admissible radial pressure on the bearing, to be taken equal to 100 N/mm².

10 Split hopper dredgers and split hopper units: decks hinges, hydraulic jack connections and chocks

10.1 General

10.1.1 For ships with one of the service notations **split hopper dredger** or **split hopper unit**, the scantlings of the deck hinges and the hydraulic jack attachments connecting the two half-hulls are to be determined according to [10.5] or by direct calculation.

The loads to be considered are the result of the most unfavourable combination of simultaneous static and dynamic forces (see [10.3] and [10.4]), calculated for the loading conditions in [3.2.1].

10.1.2 The locking devices of the two half-hulls, if any, are to be examined by the Society on a case-by-case basis.

10.2 Arrangements

10.2.1 Transverse chocks to be used upon closing the two half-hulls are to be provided in the bottom area, preferably in way of the hydraulic cylinders. These chocks may consist of heavy plates inserted in the bottom plating. They are to be arranged to come into contact before the end of the stroke of the jack, upon closing.

Moreover, if the calculation of the longitudinal strength is carried out assuming the hopper well ends are partly fixed, transverse chocks are to be provided at deck level.

10.2.2 Longitudinal chocks are to be provided at bottom and deck level, to prevent relative displacement of the two half-hulls. Deck longitudinal chocks must also act in the open position.

For units of a capacity less than 700 m³, longitudinal deck chocks need not be provided; in such case, one of the two deck hinges is to be designed to fulfil the function of a chock. The other hinge is then to have sufficient clearance.

10.3 Static forces

10.3.1 The method of calculation in [10.3.2] to [10.3.9] enables the determination of the static forces in the hydraulic jack, in the chocks and in the deck hinges only if the following conditions are met:

- the total number of hydraulic jacks connecting the two half-hulls is even
- there are no superposed jacks in the same section
- there is a deck hinge at each end of the hopper well.

Any other arrangement is to be examined by the Society on a case-by-case basis.

10.3.2 In the case of maximum loading corresponding to the dredging freeboard, the forces exerted on a half-hull to be considered to calculate the static forces in the hinges, transverse bottom chocks and jacks are shown in Fig 14 as well as their lever arm in relation to the deck hinge pins.

10.3.3 The horizontal static forces to be considered are the following:

- horizontal hydrostatic buoyancy F_h on the full length of the well, in kN. This force takes into account the hydrostatic buoyancy due to the water located between the two half-hulls below the sealing joint situated at the lower part of the hopper well, taken equal to:

$$F_h = 5,026 (T_D - a)^2 \ell_p$$

- horizontal pressure of the spoil F_d , in kN, taken equal to:

$$F_d = 4,904 \delta (h_{Di} - a)^2 \ell_p$$

- force F_{CY} in each jack, in kN, equal to the greater of F_{MC} and F_p
- force F_{CH} in each hinge, in kN, taken equal to:

$$F_{CH} = 0,5 \left[F_h - F_d + n_1 \left(1 - \frac{a_3}{a_4} \right) F_{CY} + \frac{M}{a_4} \right]$$

- force F_B in each bottom transverse chock, in kN, taken equal to:

$$F_B = \frac{n_1 a_3 F_{CY} - M}{n_2 a_4}$$

where:

F_{MC} : Minimum force required to keep the dredger closed in the loading case considered, obtained from the following formula:

$$F_{MC} = M / n_1 a_3$$

For a tendency to close, F_{MC} is negative and is not to be taken into account to determine F_{CY}

F_p : Force in the jack corresponding to a pressure on the rod side equal to the maximum pressure P_p of the pumps and of their pressure limiting device

Figure 14 : Forces exerted on a half-hull

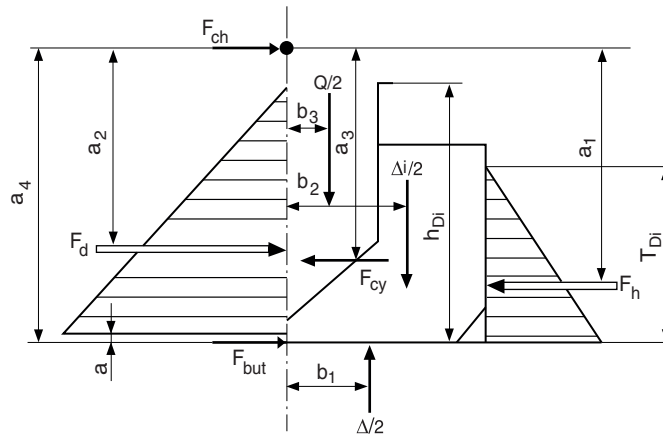

M : Moment with respect to the hinge chocks, positive for a tendency to open, negative in the opposite case, taken equal to:

$$M = -F_h a_1 + F_d a_2 + \frac{1}{2}(\Delta b_1 - \Delta_1 b_2 - Q b_3)$$

n_1 : Number of jacks

n_2 : Number of bottom transverse chocks

$\Delta, \Delta_1 l, Q$: Vertical forces, defined in [10.3.4]

a_1, a_2, a_3, a_4 : Lever arms of horizontal forces, as shown in Fig 14

b_1, b_2, b_3 : Lever arms of vertical forces, as shown in Fig 14.

10.3.4 The vertical static forces to be considered are the following:

- vertical hydrostatic buoyancy $\Delta/2$ on a half-hull, in kN
- weight $\Delta_1 l / 2$ of the half-hull without spoil, in kN
- weight $Q / 2$ of the half spoil loading, in kN

where:

Δ : Total displacement of the ship with spoil

$\Delta_1 l$: Total displacement of the ship without spoil, including superstructures

Q : Total weight of the spoil in the well.

The following relation between vertical static forces is to be verified:

$$\Delta = \Delta_1 l + Q$$

10.3.5 For every other loading case, the forces F_{CY}, F_{CH} and F_B are to be calculated according to [10.3.3], by replacing:

- $a_1, a_2, b_1, b_2, b_3, \Delta, \Delta_1 l$ and Q by the corresponding values for the loading case considered
- T_{Di}, δ_i and h_{Di} by values of external draught, density of water or spoils in the well and level inside the well for the loading case considered, i.e.:
 - in dredging condition, at the international freeboard: T_{IF}, δ and h_{IF}
 - in dredging condition, with the well filled up to the waterline: $T_{WL}, 1,025$ and h_{WL} taken equal to T_{WL}
 - in dredging condition, with well filled with water to the lowest weir level: $T_{OL}, 1,025$ and h_{OL} .

10.3.6 If, in the maximum loading condition corresponding to the dredging freeboard or the international freeboard, densities of spoil higher than δ may be considered with reduced heights (for constant mass of spoils), calculation of F_{CY}, F_{CH} and F_B is also to be carried according to [10.3.3], using the parameters corresponding to the maximum densities of spoil likely to be considered with draughts T_{Di} and T_{IF} .

10.3.7 The maximum static force F_s , actually developed by the jack, is the greatest of the values obtained for F_{CY} for the various loading cases and calculated according to [10.3.3], [10.3.5] and [10.3.6].

10.3.8 Where the hopper well ends are partly fixed, the end moments result in additional forces in the deck hinges, jacks, deck and bottom chocks, forward and aft of the well.

The distribution of these forces is to be determined by a direct calculation to be submitted to the Society for information.

10.3.9 The Designer is to give the value of the horizontal lever arm b_2 and the hull weight for the various loading cases as stated in [10.3.3]. In each case, the value to be taken into account is the most unfavourable one according to the distribution of the compartments, considering the tendency to open or to close.

However, the attention of the Owner and of the Designer is drawn to the fact that side tank ballasting can noticeably reduce the static forces necessary in the jacks to act against opening of the two half-hulls in the above operating conditions.

10.4 Dynamic forces

10.4.1 The Designer is to give the dynamic forces applied on the deck hinges and on the hydraulic jack attachments by means of a calculation to be submitted to the Society for information.

10.4.2 The dynamic forces are generally to be calculated by means of a long-term statistical analysis, under the conditions defined in Tab 13.

Table 13 : Probability for the determination of dynamic forces

Condition	Probability
Dredging and navigation with spoil, with sea state limited to $H_s = 3$ m (1)	10^{-5} for jacks and hinges
Navigation without spoil, without limitation on sea state (2)	10^{-7} for jacks 10^{-5} for hinges
<p>(1) H_s : Significant wave height, in m. (2) In sailing condition without spoil, a different probability level may be adopted for the calculation of dynamic forces on the cylinders, subject to the Society's agreement, when a device intended to restore the pressure to the cylinders after opening of the safety valves is fitted (see also [11.3.1]). Note 1: The different calculation conditions are to be justified by the Designer.</p>	

10.4.3 For each rule loading case, the results of the calculation are to give:

- the dynamic force F_{DCY} in each jack, in kN
- the horizontal dynamic force F_{DHC} in each hinge, in kN
- the vertical dynamic force F_{DVC} in each hinge, in kN.

10.4.4 If loading cases other than those defined in [3] are considered, calculations for such additional cases are to be defined in agreement with the Society on a case-by-case basis.

10.4.5 In the case of dredgers with a capacity of less than 700 m³, the dynamic forces in the jacks and hinges may be taken into account without long-term statistical calculations. The calculations for jacks and hinges are to be justified to the Society.

10.4.6 For ships with one of the navigation notations **coastal area** or **sheltered area**, the dynamic forces in the cylinders and the hinges may be reduced by 10% in the case of navigation without spoil.

10.5 Scantlings

10.5.1 The maximum total force in the jack is to be taken equal to the greatest value, from all the loading cases foreseen, obtained, in kN, from the following formula:

$$F_m = F_{CY} + F_{DCY}$$

The jack is to be capable of developing a force at least equal to F_m , at the setting pressure of the safety valve of the jack considered as isolated.

10.5.2 The scantlings of the jack lugs are to comply with [9.5] considering the force F_m as determined in [10.5.1]. Cases where the force developed by the jack, at the setting pressure of the safety valve of the jack considered as isolated, is noticeably higher than F_m are to be examined by the Society on a case-by-case basis.

10.5.3 The scantlings of the deck hinges are to comply with [9.5], considering the resultant of the total horizontal force and the total vertical force, obtained, in kN, from the following formula:

$$F_{Res} = \sqrt{(F_{CH} + F_{DCH})^2 + F_{DVC}^2}$$

10.5.4 The scantling load of the transverse bottom chocks is to be defined in agreement with the Society.

10.5.5 The scantlings of the longitudinal bottom chocks provided for in [10.3.2] are to be determined considering for each chock the force obtained, in kN, from the following formula:

$$F = 0,15 \frac{\Delta_m}{n_3}$$

where:

Δ_m : Maximum displacement of the ship, in kN, with the well loaded with spoil

n_3 : Total number of chocks (at deck and bottom).

The scantlings of the longitudinal deck chocks mentioned in [10.3.2] are to be determined considering for each chock the force obtained, in kN, from the following formula:

$$F = 0,15 \frac{\Delta_m}{n_4}$$

where:

Δ_n : Displacement of the ship with the well filled with water up to the waterline

n_4 : Number of longitudinal deck chocks.

The permissible shear stress for bottom and deck chocks is to be obtained, in N/mm², from the following formula:

$$\tau = 0,9 \frac{R_{eH}}{\sqrt{3}}$$

For the calculation of the shear stress in the deck chocks, a reduced sectional area corresponding to the efficient sectional area of the chocks when the well is open is to be considered.

10.5.6 The lugs of the jacks and the deck hinges may be calculated using a finite element model.

In such case, the finite element model and the applied loadings are to be preliminarily agreed upon by the Society.

The permissible stress is to be defined in agreement with the Society, depending on the finite element model and on the characteristics of the materials.

11 Split hopper dredgers and split hopper units: hydraulic jacks and associated piping systems

11.1 General

11.1.1 For ships with one of the service notations **split hopper dredger** or **split hopper unit**, the check of hydraulic jacks and associated piping systems intended for closing the two half-hulls of the ship is to be carried out according to [11.1] to [11.6].

11.1.2 Hydraulic jack design and construction are to be in accordance with the applicable requirements of Pt C, Ch 1, Sec 14, [2], while associated piping systems are generally to fulfil the relevant requirements of Pt C, Ch 1, Sec 10.

Materials used are to be in accordance with the applicable requirements of NR216 Materials and Welding.

11.2 Definitions

11.2.1 For the checking of hydraulic jacks and associated piping systems, the following definitions are to be considered:

P_m : Pressure on the rod side of the jack resulting from the extreme foreseen ambient conditions corresponding to the maximum force $F_{m,r}$, defined in [10.5.1]

P_C : Maximum pressure on the bottom side of the cylinder equal to the setting value of the safety valves protecting the bottom side of the cylinder

P_p : Maximum pressure which can be delivered through the pumps and their associated pressure limiting devices

P_S : Pressure on the rod side of the jack corresponding to the greatest of forces $F_{S,r}$, defined in [10.3.7], and $F_{p,r}$, defined in [10.3.3].

11.3 Arrangements

11.3.1 When large ships are concerned, the following arrangements are generally to be provided:

- for each hydraulic jack, a measuring system of the pressure in the cylinder is to be supplied
- this system, in addition to the indication of the pressure at the bridge and at the dredging room, is to comprise a visual and audible alarm at the same locations, to be activated when a certain limit is exceeded
- the measuring system, the alarm activating limit as well as the instructions to be followed after the alarm occurs are to be submitted to the Society for approval.

11.3.2 Special attention is to be paid to protection against corrosion.

11.4 Scantling of jacks

11.4.1 For the pressure parts of hydraulic jacks made of steel, the permissible stress related to the loading conditions resulting in pressure P_p or P_S (whichever is the greater) acting on the cylinder rod side without pressure on the other side is to be taken as the smaller of $R_{eH} / 1,8$ and $R_m / 2,7$.

The allowable stress applicable to the cylindrical envelope, for the loading conditions resulting in pressure P_m , may be taken as the smaller of $R_{eH} / 1,5$ and $R_m / 2,25$.

11.4.2 The scantlings of the jack end cover on the rod side are to be determined using P_m as design pressure.

The scantlings of the jack end cover on the bottom side as well as the mechanical connections (for example the bolts between the cover and the cylinder or between the piston and the rod) are to be based on F_m .

The calculations justifying the proposed scantlings and, as the case may be, the pre-stresses are to be submitted to the Society for information.

11.4.3 The scantlings of the rod are to be based on F_m and on the smaller value of $R_{eH} / 2$ and $R_m / 2,4$, for the mean permissible stress in traction. A calculation proving the adequate buckling strength of the rod is to be submitted to the Society for information.

11.4.4 The scantlings of the lugs and the pins at each end of the hydraulic cylinder are to be based on F_m .

11.5 Inspection and testing

11.5.1 In addition to inspections required in [11.1.2], where applicable, welded joints connecting parts subject to the load F_m are to fulfil the requirements for class I pressure vessels or equivalent.

11.5.2 Completed cylinders and attached piping up to and including the first isolating valve are to undergo, at works, a pressure test at the greater of the values $1,4 P_s$ and $1,2 P_m$ applied on the rod side and a pressure test at $1,4 P_C$ on the bottom side for the fully extended position.

11.5.3 The completed hydraulic circuit is to be subjected, on board, to pressure tests at $1,4$ times the relevant maximum service pressure for normal conditions or static loads, for the part of the circuit considered.

11.6 Relief valve setting

11.6.1 At least one relief valve of appropriate capacity is to protect each part of the circuit which may be subject to overpressure due to external loads or due to pump action; in general, relief valves on the rod side of each cylinder or group of cylinders are to be set at P_{mv} while P_C applies to the bottom side for relief valve setting purposes.

Parts of the circuit possibly subject to overpressure from pumps only are to be protected by relief valves set at pressure P_p .

12 Rudders

12.1 General

12.1.1 The rudder stock diameter obtained from Pt B, Ch 12, Sec 1, [4] is to be increased by 5%.

12.2 Additional requirements for split hopper dredgers and split hopper units

12.2.1 Each half-hull of ships with one of the service notations **split hopper unit** or **split hopper dredger** is to be fitted with a rudder complying with the requirements of Pt B, Ch 12, Sec 1.

12.2.2 An automatic system for synchronising the movement of both rudders is to be fitted.

13 Equipment

13.1 General

13.1.1 The requirements of this Article apply to ships having normal ship shape of the underwater part of the hull.

For ships having unusual ship shape of the underwater part of the hull, the equipment is to be considered by the Society on a case-by-case basis.

13.1.2 The equipment obtained from [13.1.4] or [13.1.5] is independent of anchors, chain cables and ropes which may be needed for the dredging operations.

13.1.3 The Equipment Number EN is to be obtained from the following formula:

$$EN = 1,5 (L B D)^{2/3}$$

When calculating EN, bucket ladders and gantries may not be included.

13.1.4 For ships equal to or greater than 80 m in length and for ships with EN, calculated according to [13.1.3], equal to or greater than 795, the equipment is to be obtained from Pt B, Ch 12, Sec 4, [2], with EN calculated according to Pt B, Ch 12, Sec 4, [1] and not being taken less than 795, considering the following:

- to apply the formula, the displacement considered is that of the navigation draught, taking into account the cylinder housings and the free space between the two half-hulls
- the chain cable diameter is to be read off after moving to the next line below in the applicable Table.

13.1.5 For ships other than those defined in [13.1.4], the equipment is to be obtained from Tab 14.

Where such ships are assigned one of the following navigation notations:

- **summer zone**
- **tropical zone**
- **coastal area,**

the equipment is to be obtained by consulting Tab 14 one line higher.

Where such ships are assigned the navigation notation **sheltered area**, the equipment is to be obtained by consulting Tab 14 two lines higher.

Table 14 : Ships for dredging activities - Equipment

Equipment number EN A < EN ≤ B		Stockless anchors		Stud link chain cables for anchors	
A	B	N	Mass per anchor, in kg	Total length, in m	Diameter, in mm
35	45	2	120	110,0	16,0
45	60	2	140	110,0	17,5
60	80	2	220	110,0	19,0
80	92	2	260	137,5	20,5
92	102	2	290	137,5	22
102	112	2	320	165,0	24
112	130	2	350	165,0	24
130	155	2	430	165,0	26
155	185	2	500	165,0	28
185	210	2	600	165,0	30
210	250	2	700	165,0	32
250	285	2	800	220,0	34
285	315	2	900	220,0	36
315	350	2	1000	220,0	38
350	385	2	1100	220,0	38
385	415	2	1200	220,0	40
415	450	2	1300	220,0	40
450	485	2	1400	220,0	42
485	515	2	1500	220,0	44
515	550	2	1600	220,0	46
550	585	2	1700	220,0	48
585	635	2	1800	275,0	48
635	685	2	2000	275,0	50
685	715	2	2100	275,0	52
715	750	2	2200	275,0	54
750	795	2	2300	275,0	54

13.2 Additional requirements for split hopper dredgers and split hopper units

13.2.1 Arrangements of ships with one of the service notations **split hopper dredger** or **split hopper unit** are to be in accordance with [13.2.2] to [13.2.5].

13.2.2 One chain locker and one complete mooring chain cable are generally to be provided for each half-hull.

13.2.3 If the mass of the anchor permits, only one windlass needs to be provided on either of the half-hulls. In this case, in addition to the requirements in Pt B, Ch 12, Sec 4, [2], a chain stopper is to be fitted on the half-hull which is not equipped with a windlass.

13.2.4 Fairleads or rollers are to be located in suitable places between the windlass and the hawse pipe so that the dropping and the housing of the anchor are satisfactorily ensured.

13.2.5 Arrangements are to be made to avoid jamming of the cable during the opening and closing operations of the two half-hulls.

13.3 Towlines and mooring lines

13.3.1 The towline and the mooring lines are given as a guidance, but are not required as a condition of classification.

13.3.2 For ships equal to or greater than 80 m in length and ships with EN, calculated according to [13.1.3], greater than 795, the characteristics of towlines and mooring lines may be obtained from Pt B, Ch 12, Sec 4, [2] with EN calculated according to Pt B, Ch 12, Sec 4, [1], considering the displacement at navigation draught, taking into account the cylinder housings and the free space between the two half-hulls, the latter value of EN not being less than 795.

13.3.3 For ships other than those defined in [13.3.2], the characteristics of towlines and mooring lines may be obtained from Tab 15.

Table 15 : Ships for dredging activities - Towlines and mooring lines

Equipment number EN A < EN ≤ B		Towline (1)		Mooring lines (1)		
A	B	Minimum length, in m	Breaking load, in kN	N	Length of each line, in m	Breaking load, in kN
35	45	120	88	2	90	59
45	60	120	93	2	90	64
60	80	120	98	2	90	68
80	92	130	107	2	90	73
92	102	130	117	2	110	78
102	112	130	127	2	110	83
112	130	140	137	2	110	88
130	155	140	147	2	135	93
155	185	140	156	2	135	98
185	210	150	166	2	135	102
210	250	150	176	2	135	107
250	285	150	186	2	135	112
285	315	150	196	2	135	117
315	350	160	215	2	160	122
350	385	160	240	2	160	127
385	415	160	265	2	160	132
415	450	160	295	2	160	137
450	485	160	320	2	160	142
485	515	160	340	3	160	147
515	550	160	365	3	160	152
550	585	160	390	3	160	157
585	635	160	415	3	160	161
635	685	160	440	4	160	166
685	715	160	465	4	160	170
715	750	160	490	4	160	175
750	795	180	515	4	160	180

(1) The towline and the mooring lines are given as a guidance, but are not required as a condition of classification.

Section 3 Machinery and Dredging Systems

1 General

1.1 Application

1.1.1 This Section provides requirements for ships having the service notation **dredger, hopper dredger, hopper unit, split hopper unit** and **split hopper dredger**. These requirements are only applicable at the request of an Owner.

1.1.2 This Section does not cover the other aspects of the system and equipment design, in particular in respect of their performance.

1.1.3 The requirements for bottom doors and valves fitted on ships having the notation **hopper dredger, hopper unit, split hopper unit** and **split hopper dredger** are given in Ch 13, Sec 2.

2 Dredging system

2.1 Attachment of dredging equipment to the hull

2.1.1 The scantlings of the structure for attachment of the equipment intended for dredging operations (e.g. connection of the suction pipe to the hull, foundation of the suction pipe davits) are to be based on the service load of such equipment, as specified by the Designer.

In determining the above service load, the Designer is to take account of additional loads imposed by ship movements (in particular pitch and heave) in the most unfavourable sea and weather conditions expected during service.

3 Steering gear of split hopper dredgers and split hopper units

3.1 General

3.1.1 The rudder fitted to each half-hull of ships having the service notations **split hopper dredger** or **split hopper unit** (see Ch 13, Sec 2, [12.2.1]) is to be served by its own steering gear.

3.2 Design of the steering gear

3.2.1 The steering gear referred to in [3.1.1] is to consist of a control system and a power actuating system capable to operate the relevant rudder as required in Pt C, Ch 1, Sec 14, [2.2.1] or Ch 15, Sec 4, [24.3.1], as appropriate.

3.2.2 An auxiliary steering gear or a duplicated power actuating system need not be fitted.

3.3 Synchronisation

3.3.1 An automatic system for synchronising the movement of both rudders is to be fitted. It is to comply with the provisions of Pt C, Ch 1, Sec 14, [3.2.2].

4 Testing of dredging equipment

4.1 On board testing

4.1.1 Ship trials

- a) Upon completion of construction, in addition to the conventional sea trials required in Pt C, Ch 1, Sec 18, specific tests may be required at the Society's discretion in relation to the particular service for which the ship is intended or the specific characteristics of machinery and equipment fitted on board.
- b) In particular, as regards propulsion and steering systems, tests may be required to check the manoeuvring capability and the speed of the ship whilst operating.

4.1.2 Equipment trials

As far as the dredging system is concerned, tests are to be carried out to verify the proper operation of all relevant equipment in different sea and weather conditions, according to a specification submitted by the interested party.

Appendix 1 Guidance on Calculation of Transverse Strength Hopper Well Structure

1 Hopper dredgers and hopper units: checking of hopper well structure

1.1 General

1.1.1 The requirements in Articles [1] to [5] apply to ships with one of the service notations **hopper dredger** or **hopper unit**.

2 Floors

2.1 General

2.1.1 The scantlings of floors of ships with open wells fitted with bottom doors are to be obtained from a direct calculation, according to Pt B, Ch 7, Sec 6 or NR600, Ch 4, Sec 5, [1.2] as applicable, taking into account the following assumptions:

- the span is equal to half the sum of the upper face plate length and the distance between lower ends of the hopper well sloped bulkheads
- the floors have fixed ends
- the floors are subject to the uniform and concentrated loads detailed in [2.3]
- the central box (cellular keel) is supported by the floors

However, where this box has sufficient dimensions and scantlings to support a part of the loads, this may be taken into account if a relevant calculation of grid type is submitted to the Society for information.

- in addition to the loads laid down in [2.3], the floor may support differential loads, for example when all the valves are not simultaneously opened, or compression loads when the well is empty
- the web cut-out section is deducted for the calculations of shear stresses and normal stresses (tension or compression)
- for the calculation of normal stresses and bending stresses, the face plate cross-section is taken into account only if these face plates are correctly offset on the adjacent structure

2.2 Different types of bottom and valves used

2.2.1 The different types of bottom doors and valves generally used, as well as the relevant symbols, are defined in Tab 1.

2.3 Load borne by floors

2.3.1 The loads borne by floors are a combination, according to the type of bottom doors, of the elementary loads [a], [b], [c], [d], [e] and [f], obtained, in kN, from the following formulae:

[a] : Uniform load of spoils, to be taken equal to:

$$Q_1 = g \delta (D + h_D) S_a \ell$$

[b] : External hydrostatic pressure, to be taken equal to:

$$Q_2 = g (T_D - 0,5 h_0) S_a \ell$$

In the course of calculations, P_r is the reduced pressure, evenly distributed, to be taken equal to:

$$P_r = \delta (D + h_D) - (T_D - 0,5 h_0)$$

The resultant load is to be taken equal to:

$$Q = Q_1 - Q_2 = g P_r S_a \ell$$

[c] : Load acting directly on a valve (to be deducted), to be taken equal to:

$$q = g P_r A_{bd}$$

This load is assumed to be evenly distributed along the length c_1 . It is to be cut off from the load Q .

In the case of type 5 bottom doors (see Tab 1), $q = 0$

[d] : Reactions R_2 of the bottom doors on the floor (to be added), the absolute values and abscissae of which are indicated in Tab 2

Reactions R_1 on the rods of the hydraulic jacks of bottom doors type 1, type 2 and type 3 (see Tab 1) are given in Tab 2 for further calculations but they are not borne by the floors

[e] : Axial force due to the lack of spoils in the volume occupied by the cellular keel (to be deducted), to be taken equal to:

$$F_1 = g \delta S_a A$$

[f] : Axial force due to a possible transmission of the resultant reaction R_1 to the cellular keel, through a strong beam, an axial pillar or inclined pillars, to be taken equal to:

- with one axial pillar:

$$F_2 = 4 \frac{vR_1}{\ell_0}$$

- with two inclined pillars:

$$F_2 = 2 R_1$$

For determination of the scantlings of strong beams, girders and pillars, R_1 is to be replaced by F_M , in kN, when calculating F_2 , if F_M is higher than R_1 , F_M being the maximum force induced by the bottom door hydraulic jack.

where:

- h_D : Distance, in m, from the highest weir level, corresponding to the draught T_D , to the deck-line (h_D is to be counted negatively where the level is located below the deck-line at side)
- S_a : Transverse primary supporting ring spacing, in m
- ℓ : Stiffener span, in m
In the case of floors, the span is equal to half the sum of the length of the upper flange plate and the distance between the lower ends of the sloping sides of the hopper space.
- h_0 : Ship relative motion, in m, taken equal to h_w as defined in Pt B, Ch 5, Sec 5 or to h_1 , as defined in NR600, Ch 3, Sec 3, as applicable
- A_{bd} : Whole sectional area, in m^2 , of the bottom door whatever its type may be
- A : Area, in m^2 , enclosed by the contour of the cellular keel
- v : Distance, in m, from the hydraulic jack centreline to the end of the strong beam span
- ℓ_0 : Span, in m, of the strong beam bearing the reactions of the hydraulic jacks

2.4 Shear force diagrams

2.4.1 The shear force diagrams corresponding to each elementary load defined in [2.3] are given in Tab 3.

The total shear force, at abscissa X, equal to the algebraical sum of the elementary shear forces corresponding to each type of bottom doors, is indicated in Tab 4.

Table 1 : Types of bottom doors and valves

<p>Type 1 Bottom valve, centrally operated by a vertical shaft</p> 	<p>Type 2 Single bottom door, with hinges at one side (either cellular keel side or lower wing tank side) and operated by a vertical shaft at the other side</p> 	<p>Type 3 Double bottom doors, with hinges at both sides and operated by one central vertical shaft connected to the doors by means of two rods</p> 
<p>Type 4 Longitudinal sliding bottom doors</p> 	<p>Type 5 Transverse sliding bottom doors, guides being supported by floors</p> 	

Table 2 : Reactions R_1 and R_2 for elementary load [d]

Bottom door type (see Tab 1)	Reactions R_2			Reactions R_1
	No.	Value, in kN	Abscissae	Value, in kN
Type 1		0		$g A_{bd} P_r$
Type 2	1	$g A_{bd} P_r \left(\frac{2u}{c_1 + 2u} \right)$	$(a + 0,5 c_1)$ or $(a - 0,5 c_1)$	$g A_{bd} P_r \left(\frac{c_1}{c_1 + 2u} \right)$
Type 3	2	$0,25 g A_{bd} P_r \left(\frac{c_1 - 4u}{c_1 - 2u} \right)$	$(a + 0,5 c_1)$ and $(a - 0,5 c_1)$	$0,5 g A_{bd} P_r \left(\frac{c_1}{c_1 - 2u} \right)$
Type 4	2	$0,5 g A_{bd} P_r$	$(a + 0,5 c_1)$ and $(a - 0,5 c_1)$	0
Type 5		0		0

Note 1:

- a : Distance, in m, from either end of the floor span to the centreline of the bottom door closest to that end
- c_1 : Width of a bottom door, in m
- u : Distance, in m, from the fixing point of the hydraulic jack rod (or of the two rod hydraulic jack) to the centreline of the bottom door.

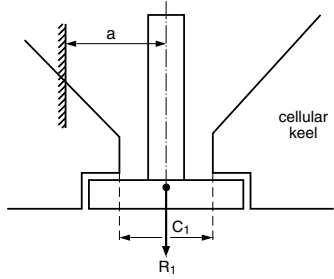
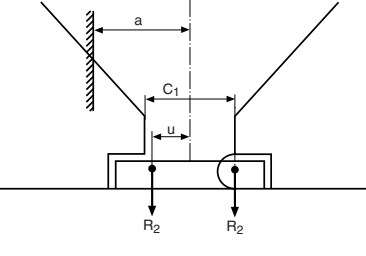
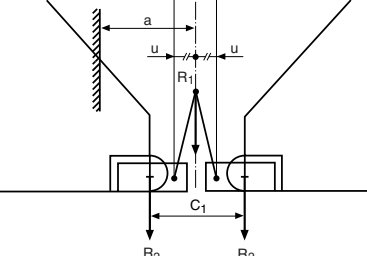
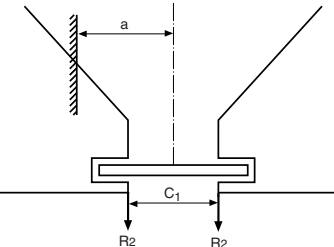
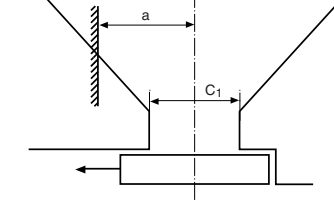
Table 3 : Shear force diagram

<p>Elementary load [a] - Load Q_1</p> 	<p>Elementary load [d] - Reactions R_2</p> <p>bottom door Type</p> 
<p>Elementary load [b] - Load Q_2</p> 	
<p>Elementary load [c] - Load q</p> 	
<p>Elementary load [e] - Force F_1</p> 	<p>Elementary load [f] - Force F_2</p> 

Table 4 : Shear force values

Bottom door type (see Tab 1)	Total shear force T(x) at abscissa X, in kN
Type 1	T_0
Type 2	$T_0 + R_2$
Type 3	$T_0 + 2 R_2$
Type 4	$T_0 + 2 R_2$
Type 5	$T_0 + q - 0,5 F_2$

Note 1:
X : Distance, in m, from the cross-section under consideration to the end of the floor span
 T_0 : Total shear force, in kN, at the left end of the span, to be taken equal to:

$$T_0 = \frac{1}{2}(Q_1 - Q_2 - 2q - F_1 + F_2)$$

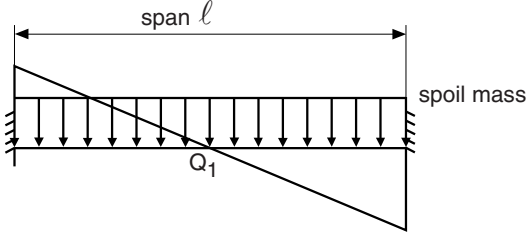
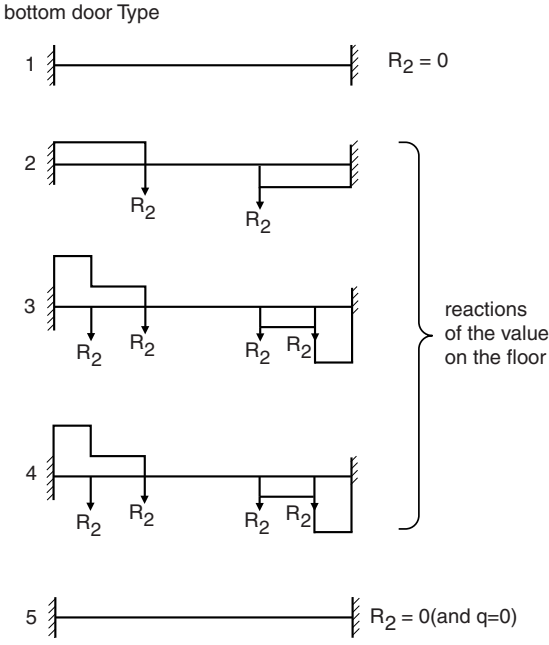
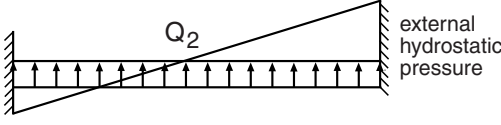
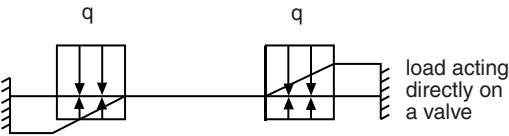
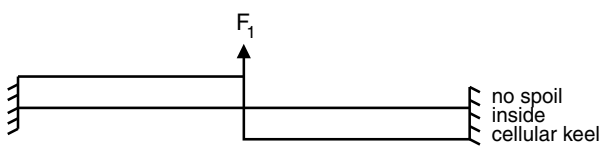
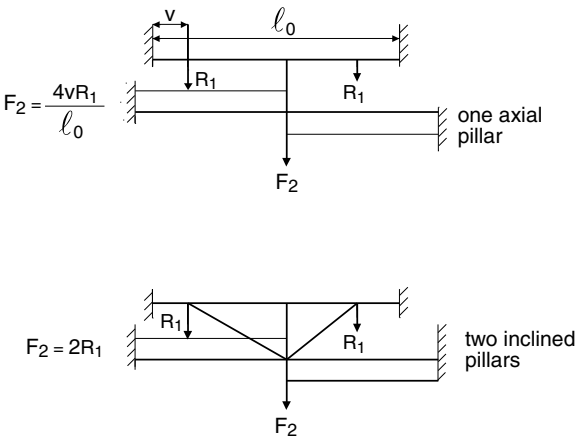
2.5 Bending moments for each elementary load

2.5.1 The bending moments for each elementary load defined in [2.3] are given in Tab 5, at span ends and at mid-span.

2.6 Resultant bending moment

2.6.1 The resultant bending moment is the sum of the elementary moments for each type of valve.

The total moment value at abscissa X is determined by deducting algebraically from the total moment value at the span ends the value of the area bounded by the total shear force curve.

2.7 Normal load

2.7.1 The normal load is to be obtained, in kN, from the following formula:

$$F_N = F_{N1} - F_{N2}$$

where:

$$F_{N1} = \frac{3,3S_a\delta}{2D - h_v}(D + h_D)^2(2D - h_D)$$

$$F_{N2} = \frac{3,3S_a}{2D - h_v}(T_D - 0,5h_0)^2(3D - T_D + 0,5h_0)$$

h_v : Mean floor depth, in m.

Table 5 : Values of bending moments

Elementary load / Bottom valve type	Bending moment, in kN.m, at span ends	Bending moment, in kN.m, at mid-span	
[a]	$-\frac{Q_1\ell}{12}$	$\frac{Q_1\ell}{24}$	
[b]	$\frac{Q_2\ell}{12}$	$-\frac{Q_2\ell}{24}$	
[c]	$\frac{qa(\ell - a)}{\ell}$	$-\frac{qa^2}{\ell}$	
[d]	Type 1 or Type 5	0	
	Type 2	$-R_2 \frac{(2a + c_1)(2\ell - 2a - c_1)}{4\ell}$ (1)	$R_2 \frac{(2a + c_1)^2}{4\ell}$
	Type 3 or Type 4	$-R_2 \left[\frac{4a(\ell - a) - c_1^2}{2\ell} \right]$	$R_2 \left[\frac{4a^2 + c_1^2}{2\ell} \right]$
[e]	$\frac{F_1\ell}{8}$	$-\frac{F_1\ell}{8}$	
[f]	$-\frac{F_2\ell}{8}$	$\frac{F_2\ell}{8}$	

(1) Formula valid for a hinge on cellular keel. In the case of a hinge on lateral wing tank, replace $(2a + c_1)$ with $(2a - c_1)$

2.8 Differential opening valves

2.8.1 In the case of a differential opening of the valves, the stresses induced by the bending moments and the shear forces are determined as follows:

- the upper flange is assumed to be simply supported at ends; its span ℓ_s is measured between the longitudinal bulkhead and the cellular keel
- the lower flange is assumed to have fixed ends and its span is taken equal to c_1
- the transverse section moduli of the flanges are determined with respect to a vertical axis located in the plane of the floor web
- for the upper flange, the transverse bending moment at mid-span is obtained, in kN.m, from the following formula:

$$M_s = 0,05 \delta h_v^2 [3 \ell_s^2 - (\ell_s - c_1)^2]$$

- for the upper flange, the maximum shear force at ends of span ℓ_s is obtained, in kN.m, from the following formula:

$$T_s = 0,3 \delta h_v^2 (\ell_s + c_1)$$

- for the lower flange, the maximum bending moment and shear force at span ends are obtained, in kN.m, from the following formulae:

$$M_i = 1,33 \left(\frac{c_1}{\ell_s} \right)^2 M_s$$

$$T_i = 2 \left(\frac{c_1}{\ell_s} \right) T_s$$

2.9 Buckling of upper flange

2.9.1 When the ship is to navigate with empty hopper space(s), the buckling of the upper flange is to be checked, using the formulae given in [3] for strong beams and assuming that:

$$F_R = \frac{-3,3 S_a}{2D - h_v} (T_2 + 0,5 h_0)^2 (3D - T_2 - 0,5 h_0) \frac{A_s}{A_v}$$

where:

- T_2 : Maximum draught for navigation with empty hopper space(s), in m
- A_s : Sectional area, in cm², of the upper flange
- A_v : Sectional area, in cm², of the floor, cut-outs in web deducted

3 Strong beams at deck level

3.1 Forces acting on strong beams

3.1.1 Where strong beams are fitted at deck level, the forces acting on them are to be obtained, in kN, from the following formulae:

- tension force due to the spoil pressure onto the longitudinal bulkheads of the well:

$$F_T = \frac{1,6 \delta s (D + h_D)^2}{2D - h_v} [2(D + h_D) - 3h_v]$$

- compression force due to the external hydrostatic pressure:

$$F_{C1} = \frac{1,6 s (T_D - 0,5 h_0)^2}{2D - h_v} (2T_D - h_0 - 3h_v)$$

- compression force due to moment at floor ends:

$$F_{C2} = \frac{2M(0)}{2D - h_v}$$

- compression force due to floor reaction at span ends:

$$F_{C3} = \frac{d_1 + 2b_1}{2D - h_v} T(0)$$

where:

- s : Spacing of strong beams, in m
- d_1 : Distance, in m, from the side plating to the longitudinal bulkhead of the hopper well
- b_1 : Distance, in m, between the fixed end of the floor and the hopper well longitudinal bulkhead or its extension

$M(0)$, $T(0)$: Total bending moment and shear force at fixed ends, determined, respectively, according to [2.5] and [2.4], for $X = 0$. For strong beams with a large web depth, the upper flange of which is located at deck level, the term D may be replaced by $(D - 0,5 h_{ws})$, where h_{ws} is the web depth, in m, of strong beams.

The resultant of the forces is to be obtained, in kN, from the following formula:

$$F_R = F_T - F_{C1} - F_{C2} - F_{C3}$$

F_R is a tension load when positive, a compression load when negative.

3.2 Sectional area of strong beams

3.2.1 The sectional area of strong beams, after deduction of possible cut-outs, is to be obtained, in cm², from Tab 6.

Table 6 : Sectional area of strong beams

Condition	Sectional area A_T , in cm ²	
$F_R \geq 0$	0,08 F_R	
$F_R < 0$	when $\ell_F / r \leq 1,15$	$\left[0,085 + 0,064 \left(\frac{\ell_F}{r} \right)^2 \right] F_R$
	when $\ell_F / r > 1,15$	$0,1 \left(\frac{\ell_F}{r} \right)^2 F_R$
Note 1:		
ℓ_F	: Buckling length, in m, of the strong beam considered as fixed at ends, to be taken equal to $0,5\ell_0$	
r	: Minimum gyration radius, in cm, to be taken equal to:	
	$r = \sqrt{\frac{I}{A_T}}$	
I	: Moment of inertia, in cm ⁴ , equal to the minimum of I_{XX} and I_{YY}	
I_{XX}	: Moment of inertia, in cm ⁴ , with respect to the axis perpendicular to the plane of the web	
I_{YY}	: Moment of inertia, in cm ⁴ , with respect to the axis parallel to the plane of the web.	

4 Brackets for trunks

4.1 General

4.1.1 Brackets for trunks are to be provided in way of the strengthened transverse rings. They are to be securely fixed at their lower ends.

4.1.2 In order to check the stresses according to [4.1.3], the value of the bending moment at the lower end, in kN.m, and the value of the corresponding shear stress, in kN, may be obtained, respectively, from the following formulae:

$$M_p = 1,64 \delta s h_T^3$$

$$T_p = 4,9 \delta s h_T^2$$

where:

h_T : Height, in m, of the trunk above the deck-line.

4.1.3 It is to be checked that the normal stress, in N/mm², and the shear stress are, respectively, in compliance with the following formulae:

$$\sigma \leq 0,65 R_Y$$

$$\tau \leq 0,45 R_Y$$

5 Girders supporting the hydraulic cylinder in the hopper spaces (bottom door types 1, 2 and 3)

5.1

5.1.1 In order to check the stresses according to [5.1.2], the local bending stress due to the cylinder reaction and the corresponding shear stress, in N/mm², may be obtained, respectively, from the following formulae:

$$\sigma_{LX} = \frac{125F\ell}{w}$$

$$\tau_{XY} = \frac{5F}{A_a}$$

where:

F : Maximum value, in kN, of R_1 and F_M defined in [2.3]

w : Girder web modulus, in cm³

A_a : Girder web sectional area, in cm^2 , possible cut-outs deducted.

5.1.2 It is to be checked that the normal stress, in N/mm^2 , and the shear stress are, respectively, in compliance with the following formulae:

$$\sigma \leq 0,65 R_y$$

$$\tau \leq 0,45 R_y$$

Part D

Service Notations

CHAPTER 14

NON-PROPELLED UNITS

- Section 1 General
- Section 2 Hull and Stability
- Section 3 Machinery Systems

Section 1 General

1 General

1.1 Application

1.1.1 Ships complying with the requirements of this Chapter are eligible for the assignment of one of the following notations applicable to non propelled units, as defined in Pt A, Ch 1, Sec 2, [4.14]:

- service notations:
 - **barge**
 - **pontoon**
 - **pontoon-crane**
- additional service feature:
 - **non propelled.**

1.1.2 Ships dealt with in this Chapter are to comply with:

- Part A of the Rules
- NR216 Materials and Welding
- applicable requirements according to Tab 1.

1.1.3 For ships dealing with in this Chapter and intended to carry only one type of cargo, the Society reserves the right to establish requirements and/or conditions additional to those contained in these Rules.

Table 1 : Applicable requirements

Item		Greater than or equal to 500 GT	Less than 500 GT
Ship arrangement	L ≥ 65 or 90 m (1)	• Part B	• NR566
	L < 65 or 90 m (1)	• NR600	• NR566
Hull	L ≥ 65 or 90 m (1)	• Part B • Ch 14, Sec 2	• Part B • Ch 14, Sec 2
	L < 65 or 90 m (1)	• NR600	• NR600
Stability		• Part B • Ch 14, Sec 2	• NR566 • Ch 14, Sec 2
Machinery and cargo systems		• Part C • Ch 14, Sec 3	• NR566 • Ch 14, Sec 3
Electrical installations		• Part C	• NR566
Automation		• Part C	• NR566
Fire protection, detection and extinction		• Part C	• NR566
<p>(1) Refer to the scope of application of NR600. Note 1: NR566: Hull Arrangement, Stability and Systems for Ships less than 500 GT. NR600: Hull Structure and Arrangement for the Classification of Cargo Ships less than 65 m and Non Cargo Ships less than 90 m.</p>			

Section 2 Hull and Stability

1 General

1.1 Application

1.1.1 General

Unless otherwise specified, the requirements of this Section apply to ships with one of the service notations **barge**, **pontoon** and **pontoon - crane**.

Specific requirements which apply only to ships with the service notation **barge** or ships with the service notation **pontoon** or **pontoon- crane** are indicated.

Barges with the additional service feature **tug combined** are also to comply with the applicable additional requirements in Pt E, Ch 1, Sec 4

1.1.2 Main characteristics of non-propelled units

The requirements of this Section are based on the following assumptions, relevant to the main characteristics of non-propelled units:

- the structural configuration and proportions of non-propelled units are similar to those of propelled ships
- the cargo is homogeneously distributed.

The scantlings of non-propelled units with unusual shapes and proportions or carrying cargoes which are not homogeneously distributed, such as containers or heavy loads concentrated in limited areas, are to be considered by the Society on a case-by-case basis, taking into account the results of direct calculations, to be carried out according to Pt B, Ch 8, Sec 1.

1.2 Additional class notations for lifting appliances of ships with service notation pontoon - crane

1.2.1 For ships with service notation **pontoon - crane**, one of the following additional class notations, defined in Pt A, Ch 1, Sec 2, [6.12], is generally to be granted:

- **ALP** or (**ALP**) for lifting appliances intended to be used in harbours or similar sheltered areas
- **ALM** or (**ALM**) for lifting appliances intended to be used in offshore conditions.

Note 1: when the lifting appliance is provided to be used essentially in harbour conditions or similarly sheltered areas and exceptionally in offshore conditions, the additional class notation **ALP** or (**ALP**) is generally assigned. For the exceptional using in offshore conditions, the lifting capacity is reduced to a value in accordance with the considered sea conditions.

2 Stability

2.1 Intact stability for ships with service notation pontoon or pontoon - crane

2.1.1 Application

The requirements of this item apply to seagoing ships with one of the service notations **pontoon** and **pontoon - crane** with the following characteristics:

- *unmanned*
- *having a block coefficient not less than 0,9*
- *having a breadth/depth ratio greater than 3,0*
- *having no hatchways in the deck except small manholes closed with gasketed covers.*

2.1.2 Trim and stability booklet

In addition to the information to be included in the trim and stability booklet specified in Pt B, Ch 3, App 2, [1.1], simplified stability guidance, such as a loading diagram, is to be submitted to the Society for approval, so that pontoons may be loaded in compliance with the stability criteria.

2.1.3 Stability calculations

Stability calculations may be carried out according to the following criteria:

- *no account is to be taken of the buoyancy of deck cargo (except buoyancy credit for adequately secured timber)*
- *consideration is to be given to such factors as water absorption (e.g. timber), trapped water in cargo (e.g. pipes) and ice accretion*

- in carrying out wind heel calculations:
 - the wind pressure is to be constant and for general operations considered to act on a solid mass extending over the length of the cargo deck and to an assumed height above the deck
 - the centre of gravity of the cargo is to be assumed at a point mid-height of the cargo
 - the wind lever arm is to be taken from the centre of the deck cargo to a point at one half the draught
- calculations are to be carried out covering the full range of operating draughts
- the downflooding angle is to be taken as the angle at which an opening through which progressive flooding may take place is immersed. This would not be an opening closed by a watertight manhole cover or a vent fitted with an automatic closure.

2.1.4 Intact stability criteria

The following intact stability criteria are to be complied with, for the loading conditions specified in Pt B, Ch 3, App 2, [1.2.1] and Pt B, Ch 3, App 2, [1.2.2]:

- the area under the righting lever curve up to the angle of maximum righting lever is to be not less than 0,08 m-rad
- the static angle of heel due to a uniformly distributed wind load of 0,54 kPa (wind speed 30 m/s) may not exceed a heeling angle corresponding to half the freeboard for the relevant loading condition, where the lever of wind heeling moment is measured from the centroid of the windage area to half the draught
- The minimum range of stability is to be:
 - 20° for $L < 100$ m
 - $20^\circ - 0,1^\circ (L - 100)$ for $100 \leq L \leq 150$ m
 - 15° for $L > 150$ m.

2.2 Additional intact stability criteria for ships with service notation pontoon - crane

2.2.1 Ships assigned with the service notation **pontoon-crane** are to comply with the stability criteria during lifting operations specified in Pt E, Ch 8, Sec 3, in addition to those in [2.1].

3 Structure design principles

3.1 Hull structure

3.1.1 Framing of ships with one of the service notations pontoon and pontoon - crane

In general, ships with one of the service notations **pontoon** and **pontoon - crane** are to be longitudinally framed.

3.1.2 Supports for docked non-propelled units

Adequate supports are to be fitted on the longitudinal centreline in order to carry loads acting on the structure when the non-propelled units are in dry dock.

3.1.3 Truss arrangement supporting deck loads

Where truss arrangements are used as supports of the deck loads, including top and bottom girders in association with pillars and diagonal bracing, the diagonal members are generally to have angles of inclination with the horizontal of about 45° and cross-sectional area of about 50% that of the adjacent pillars.

Where pillar arrangements are used without diagonal bracing, the scantlings of primary members can generally not be determined by means of isolated beam structural models.

3.2 Lifting appliances

3.2.1 Crane or derrick position during navigation

For ships with the service notation **pontoon - crane**, it is to be possible to lower the crane boom or the derrick structure and to secure them to the pontoon during the voyage.

4 Hull girder strength

4.1 Yielding check

4.1.1 Non-propelled units lifted by crane

For non-propelled units intended to be lifted on board ship by crane, the hull girder strength is to be checked, in the condition of fully-loaded barge lifted by crane, through criteria to be agreed with the Society on a case-by-case basis.

In general, the equivalent Von Mises stress σ_{eq} in the hull girder when lifted by crane are to comply with the criteria defined in Pt B, Ch 6, Sec 1, [3.5] for harbour/sheltered operations.

4.1.2 Ships with service notation pontoon carrying special cargoes

For ships with the service notation **pontoon** intended for the carriage of special cargoes, such as parts of offshore units, the hull girder strength is to be checked through criteria to be agreed with the Society on a case-by-case basis.

Moreover, where these ships are fitted with arrangements for launching the above special cargoes, additional calculations are to be carried out in order to evaluate the stresses during the various stages of launching. The Society may accept stresses higher than those in [4.1.1], to be considered on a case-by-case basis, taking into account favourable sea and weather conditions during launching.

4.1.3 Ships with service notation pontoon - crane

For ships with the service notation **pontoon - crane** having length greater than 65 m, the hull girder strength is to be checked when the lifting appliance is operated, in accordance with the requirements of Pt E, Ch 8, Sec 4.

5 Hull scantlings

5.1 General

5.1.1 Net thickness of strength deck plating

Within the cargo area, the thickness of strength deck plating is to be increased by 1,5 mm with respect to that calculated according to Pt B, Ch 7, Sec 4.

5.2 Hull scantlings of non-propelled units with the service notation pontoon fitted with arrangements and systems for launching operations

5.2.1 Additional information

In addition to the documentation specified in Pt B, Ch 1, Sec 4, the following information is to be submitted to the Society:

- maximum draught of the ship during the different stages of the launching operations
- operating loads and their distribution
- launching cradle location.

5.2.2 Scantlings draught

T_{SC} is to be taken not less than the maximum draught resulting from the different stages of launching.

5.2.3 Deck scantlings

The scantlings of decks are to be in accordance with Part B, Chapter 7, considering the maximum loads acting on the launching cradle.

The thickness of deck plating in way of launch ground ways is to be suitably increased if the cradle may be placed in different positions.

The scantlings of decks in way of pivoting and end areas of the cradle are to be obtained through direct calculations, to be carried out according to the criteria in Pt B, Ch 8, Sec 1.

5.2.4 Launching cradles

The launching cradles are to be adequately connected to deck structures and arranged, as far as possible, in way of longitudinal bulkheads or at least of girders.

5.3 Hull scantlings of non-propelled units with service notation pontoon - crane

5.3.1 Loads transmitted by the lifting appliances

The forces and moments transmitted by the lifting appliances to the ship's structures, during both lifting service and navigation, are to be submitted to the Society in the initial stage of the design.

5.3.2 Ship's structures

The ship's structures, subjected to the forces transmitted by the lifting appliances, are to be reinforced to the Society's satisfaction.

5.3.3 Lifting appliances

The check of the behaviour of the lifting appliances at sea is outside the scope of the classification and is under the responsibility of the Designer. However, where the requirements in [3.2.1] may not be complied with (i.e. sailing with boom or derrick up) or where, exceptionally, trips with suspended load are envisaged, the Designer is to submit the check of the lifting appliances during navigation to the Society for information.

6 Hull outfitting

6.1 Equipment

6.1.1 Manned non-propelled units

The equipment of anchors, chain cables and ropes to be fitted on board manned non-propelled units is to comply with Pt B, Ch 12, Sec 4.

Chain cables for anchors may be replaced by steel ropes having the same breaking load. The ropes are to be connected to the anchors by approximately 10 m of chain cable complying with Pt B, Ch 12, Sec 4.

Non-propelled units continuously assisted by a tug may have only one anchor complying with Pt B, Ch 12, Sec 4 and a chain rope having length neither less than 75% of the length obtained according to Pt B, Ch 12, Sec 4 nor less than 220 m.

6.1.2 Unmanned non-propelled units

For unmanned non-propelled units, the equipment is not required for classification purposes. The scantlings of anchors, chain cables and ropes to be fitted on board are the responsibility of the Designer.

6.1.3 Towing arrangements

Non-propelled units are to be fitted with suitable arrangements for towing, with scantlings under the responsibility of the Designer.

The Society may, at the specific request of the interested parties, check the above arrangements and the associated hull strengthening; to this end, the maximum pull for which the arrangements are to be checked is to be specified on the plans.

Section 3 Machinery and Systems

1 General

1.1 Application

1.1.1 This Section provides requirements for bilge systems of non propelled units.

1.2 Documents to be submitted

1.2.1 The documents listed in Tab 1 are to be submitted for approval.

Table 1 : Documents to be submitted

No.	Description of the document (1)	Status of the review
1	Diagram of the bilge system	A
2	Diagram of the central priming system intended for the bilge pumps, where provided	A
3	Capacity, prime mover and location of the bilge pumps	A

(1) Diagrams are also to include, where applicable, the (local and remote) control and monitoring systems and automation systems.

2 Bilge system

2.1 Bilge system in ships having no source of electrical power

2.1.1 General

Where there is no source of electrical power on board, hand pumps are to be provided, in sufficient number and so positioned as to permit an adequate drainage of all the compartments of the ship.

2.1.2 Arrangement of the bilge system

The bilge system is to comply with one of the following arrangements:

- at least one pump is to be provided for each compartment
- at least two pumps connected to a bilge main are to be provided. The main is to have branch pipes allowing the draining of each compartment through at least one suction.

2.1.3 Hand pumps

- Hand pumps are to be capable of being operated from positions above the load waterline and are to be readily accessible at any time.
- Hand pumps are to have a maximum suction height not exceeding 7,30 m.

2.1.4 Size of bilge pipes

- The internal diameter, in mm, of suction pipes is not to be less than the diameter given by the following formula:

$$d_1 = \frac{T}{100} + 50$$

where:

T : Underdeck tonnage, in t.

- When the ship is subdivided into small watertight compartments, the diameter of these suctions need not exceed 50 mm.

2.2 Bilge system in ships having a source of electrical power

2.2.1 General

On board ships having no propelling machinery but having a source of electrical power, mechanical pumps are to be provided for draining the various compartments of the ship.

2.2.2 Arrangement of the bilge system

The bilge system is to comply with the provisions of Pt C, Ch 1, Sec 10, [6.3] to Pt C, Ch 1, Sec 10, [6.6] applicable to the spaces concerned, except that direct suctions need not be provided.

2.2.3 Bilge pumps

The number and capacity of the bilge pumps are to comply with the relevant requirements of Pt C, Ch 1, Sec 10, [6.7].

2.2.4 Size of bilge pipes

The size of bilge pipes is to comply with the relevant requirements of Pt C, Ch 1, Sec 10, [6.8].

Part D

Service Notations

CHAPTER 15

FISHING VESSELS

Section 1	General
Section 2	Ship Arrangement
Section 3	Hull and Stability
Section 4	Machinery
Section 5	Electrical Installations
Section 6	Fire Protection

Section 1 General

1 General

1.1 Application

1.1.1 Ships complying with the requirements of this Chapter are eligible for the assignment of the service notation **Fishing vessel**, as defined in Pt A, Ch 1, Sec 2, [4.8].

1.1.2 Ships dealt with in this Chapter are to comply with:

- Part A of the Rules
- NR216 Materials and Welding
- applicable requirements according to Tab 1.

Table 1 : Applicable requirements

Item		Reference
Ship arrangement	L ≥ 65 or 90 m (1)	<ul style="list-style-type: none"> • Part B • Ch 15, Sec 2
	L < 65 or 90 m (1)	<ul style="list-style-type: none"> • NR600
Hull	L ≥ 65 or 90 m (1)	<ul style="list-style-type: none"> • Part B • Ch 15, Sec 3
	L < 65 or 90 m (1)	<ul style="list-style-type: none"> • NR600
Stability		<ul style="list-style-type: none"> • Part B • Ch 15, Sec 3
Machinery and cargo system		<ul style="list-style-type: none"> • Part C • Ch 15, Sec 4
Electrical installations		<ul style="list-style-type: none"> • Part C • Ch 15, Sec 5
Automation		<ul style="list-style-type: none"> • Part C
Fire protection, detection and extinction		<ul style="list-style-type: none"> • Part C • Ch 15, Sec 6 (2)
<p>(1) Refer to the scope of application of NR600.</p> <p>(2) Articles Ch 15, Sec 6, [5], Ch 15, Sec 6, [6], Ch 15, Sec 6, [7], Ch 15, Sec 6, [8], Ch 15, Sec 6, [9] and Ch 15, Sec 6, [10] apply only to ships assigned with the additional service feature F.</p> <p>Note 1: NR600: Hull Structure and Arrangement for the Classification of Cargo Ships less than 65 m and Non Cargo Ships less than 90 m.</p>		

Section 2 Ship Arrangement

1 General

1.1 Definitions

1.1.1 Working deck

The working deck is generally the lowest complete exposed deck above the deepest operating waterline from which fishing is undertaken.

The Society may accept a lower complete deck as a working deck provided that such a deck is situated above the deepest operating waterline.

2 General arrangement design

2.1 Subdivision arrangement

2.1.1 Disposition of collision bulkhead

The collision bulkhead is to be located at a distance from the forward perpendicular FP_{LL} of not less than 5% and no more than 8% of the length L_{LL} of the ship.

Where any part of the ship below the waterline extends forward perpendicular, e.g. a bulbous bow, the above distance, in m, are to be measured from a point either:

- at mid-length of such extension, or
- at a distance 1,5% of the length L_{LL} of the ship forward of the forward perpendicular, where this distance is lesser.

2.1.2 Height of transverse watertight bulkheads

Transverse watertight bulkheads are to be watertight up to the working deck.

Where a long forward superstructure is fitted, the collision bulkhead is to be extended weathertight to the next deck above the working deck. The extension need not be fitted directly above the bulkhead below provided it is located within the limits prescribed in [2.1.1] and the part of the deck which forms the step is made effectively watertight.

2.1.3 Openings in collision bulkhead

Openings in the collision bulkhead below the working deck are not allowed.

Where penetration of the collision bulkhead is necessary for piping, arrangements are to be fitted to maintain the watertight integrity and strength, with suitable valves operable from above the freeboard deck, whose valve chest is to be secured at the bulkhead inside the fore peak.

Where the collision bulkhead extends above the working deck, openings above the working deck are allowed provided that they are supplied with weathertight means of closure.

2.1.4 Openings in watertight bulkheads

The number of openings in watertight bulkheads is to be kept to a minimum compatible with the design and proper working of the ship.

Where penetration of watertight bulkheads and internal decks is necessary for access, piping, ventilation, electrical cables, etc., arrangements are to be fitted to maintain the watertight integrity and strength.

Section 3 Hull and Stability

1 General

1.1 Documents to be submitted

1.1.1 In addition to the documentation requested in Part B, the following documents and information are to be submitted:

- minimum design temperature of refrigerated spaces,
- structural reinforcements in way of load carrying structures, such as masts, gantries, trawl gallows and winches, including the maximum brake load of the winches.

2 Stability

2.1 Intact stability

2.1.1 Application

The stability of the ship for the loading conditions in Pt B, Ch 3, App 2, [1.2.14], with the assumptions in [2.1.2], is to be in compliance with the requirements in [2.1.3].

2.1.2 Assumptions for calculating loading conditions

The assumptions for calculating the loading conditions in Pt B, Ch 3, App 2, [1.2.14] are as follows:

- allowance is to be made for the weight of the wet fishing nets and tackle, etc., on deck
- in all cases the cargo is to be assumed to be homogeneous unless this is inconsistent with practice
- deck cargo is to be included if such a practice is anticipated
- water ballast is normally to be included only if carried in tanks which are specially provided for this purpose.

2.1.3 Intact stability criteria

- The general intact stability criteria in Pt B, Ch 3, Sec 2, [2] are to be applied to fishing vessels equal to or greater than 24 m in length, except for the requirements below.
- The initial metacentric height GM_0 is to be not less than 0,35 m for single deck vessels.
- The metacentric height GM_0 may be reduced to the satisfaction of the Society but in no case is GM_0 to be less than 0,15 m for vessels with complete superstructure or vessels equal to or greater than 70 m in length.

Where arrangements other than bilge keels are provided to limit the angle of roll, the above stability criteria are to be maintained in all operating conditions.

2.1.4 Severe wind and rolling criterion (weather criterion)

The requirements in Pt B, Ch 3, Sec 2, [3] are to be complied with by:

- fishing vessels equal to or greater than 45 m in length
- fishing vessels in the length range between 24 m and 45 m, with the values of wind pressure defined in Tab 1, depending on the vertical distance h , in m, measured from the centre of the projected vertical area of the ship above the waterline to the waterline.

2.1.5 Icing

For vessels operating in areas where ice accretion is expected, the requirements in Pt B, Ch 3, Sec 2, [6] are to be complied with.

Table 1 : Values of wind pressure

Vertical distance h , in m	Wind pressure, in kN/m ²
1	0,316
2	0,386
3	0,429
4	0,460
5	0,485
6 and over	0,504

3 Design loads

3.1 Fish holds

3.1.1 The internal liquid pressures in fish holds are to be determined according to Pt B, Ch 5, Sec 6, [1] with p_c as defined by the Designer. As a guidance, p_c may be taken as follows:

- 0,7 for holds intended to carry dry fish or fish stored in ice,
- 1,025 for holds intended to carry live fish or frozen fish into sea water,
- 1,2 for holds intended to freeze or store fish into brine.

Note 1: If applicable, a design vapour pressure P_{pv} is to be considered for live fish stored in sea water to take into account the injection of oxygen.

Note 2: In case of salt stored onboard for brine production, weight of salt and associated distribution along the ship are to be provided.

3.2 Working deck

3.2.1 The static pressure P_{dl-s} to be considered on working decks is to be taken as defined by the Designer, without being less than 8,5 kN/m².

4 Hull scantlings

4.1 Fish holds

4.1.1 Fish holds scantlings are to be checked according to the applicable requirements of Part B, Chapter 7 for the design load sets LC-1, LC-3 and LC-4 as defined in Pt B, Ch 7, Sec 2, [2].

4.1.2 The thickness of fish holds plating is to be increased by 1 mm with respect to that calculated according to Pt B, Ch 7, Sec 4. This thickness increase is to be combined with the one defined in [4.2.1] if applicable.

4.2 Bottom, side and decks plating

4.2.1 The thickness of bottom, side and exposed decks other than superstructures plating is to be increased by 0,5 mm with respect to that calculated according to Pt B, Ch 7, Sec 4. This thickness increase is to be combined with the one defined in [4.1.2] if applicable.

4.3 Aft ramp

4.3.1 Plating of the aft ramp and of the lower part of the aft ramp side

The plating thickness of the aft ramp and of the lower part of the aft ramp sides is to be increased by 1,5 mm with respect to that calculated according to Pt B, Ch 11, Sec 3, [5] for side plating with the same plate panel dimensions.

The net plating thickness of the aft ramp and of the lower part of the aft ramp side is to be not less than 10,5 mm.

4.3.2 Plating of the upper part of the aft ramp sides

The plating thickness of the upper part of the aft ramp sides is to be not less than the value calculated according to Pt B, Ch 11, Sec 3, [5] for side plating with the same plate panel dimensions.

5 Arrangement for hull and superstructure openings

5.1 General

5.1.1 Door sills

The height of the sill of the doors is to be not less than:

- 600 mm above the working deck
- 300 mm above the deck of the lowest tier of superstructures.

For doors protected from the direct impact of waves, except for those giving direct access to machinery spaces, the height of the sill may be taken not less than:

- 380 mm above the working deck
- 150 mm above the deck of the lowest tier of superstructures

6 Lifting appliances and fishing devices

6.1 General

6.1.1 The limits of application to lifting appliances are defined in Pt B, Ch 1, Sec 1, [1.2].

6.1.2 The requirements in [6] apply to the reinforcements under decks supporting fishing devices, and to the strength check of fishing devices and masts if welded to the deck.

6.2 Design loads

6.2.1 The design loads and load angles to be considered for the strength check of masts, fishing devices and reinforcements under decks are to be submitted by the Designer based on the following assumptions:

- the weights of booms and net hauling fittings
- the cargo loads, to be taken equal to the maximum traction loads of the different lifting appliances, considering the rolling-up diameters defined in [6.2.2].

6.2.2 The rolling-up diameters to be taken for the maximum traction loads of the lifting appliances are:

- for the fishing winches: the mid rolling-up diameter
- for the net winches: the maximum rolling-up diameter
- for the winding-tackles: the minimum rolling-up diameter.

6.3 Strength check

6.3.1 Calculation of stresses in the structural elements

The stresses in the structural elements of masts, fishing devices and reinforcements under decks are to be obtained by means of direct calculations, using the design loads specified in [6.2].

6.3.2 Yielding check

The Von Mises equivalent stresses in the structural elements of masts, fishing devices and reinforcements under decks are to comply with the following formula:

- for beam grillage analysis:
 $\sigma_{eq} \leq 0,5 R_{eH}$
- for standard mesh FE analysis (s x s):
 $\sigma_{eq} \leq 0,6 R_y$
- for fine mesh FE analysis (50 x 50 mm):
 - for elements not adjacent to welding:
 $\sigma_{eq} \leq R_y$
 - for elements adjacent to welding:
 $\sigma_{eq} \leq 0,9 R_y$

where:

σ_{eq} : Von Mises equivalent stress, in N/mm², to be obtained as a result of direct calculations

6.3.3 Buckling check

The buckling strength of the structural elements of masts and fishing devices is to be checked in compliance with Part B, Chapter 9.

7 Hull outfitting

7.1 Rudder stock scantlings

7.1.1 The rudder stock diameter is to be increased by 5% with respect to that obtained from the formula in Pt B, Ch 12, Sec 1, [4].

7.2 Equipment

7.2.1 General

Anchors referred to in this section are bower anchors.

Fishing vessels are to be provided with equipment in anchors, chain cables and ropes to be obtained from Tab 2, based on their Equipment Number EN, to be calculated according to Pt B, Ch 12, Sec 4, [1].

The equipment in anchors, chain cables and ropes of fishing vessels with the navigation notation **coastal area** may be obtained from Tab 2 based on the Equipment Number EN corresponding to the row above that relevant to the Equipment Number calculated for the ship considered.

In general, stockless anchors are to be adopted.

For ships with EN greater than 720, the determination of the equipment is to be considered by the Society on a case-by-case basis. The mooring lines are given as a guidance, but are not required as a condition of classification.

Table 2 : Equipment

Equipment number EN A < EN ≤ B		Stockless bower anchors		Stud link chain cables for bower anchors			Mooring lines (1)		
A	B	N	Mass per anchor, in kg	Total length, in m	Diameter, in mm		N	Length of each line, in m	Ship design minimum breaking load, in kN
					mild steel	high strength steel			
10	15	2	30	110	11	11	–	–	–
15	20	2	40	110	11	11	–	–	–
20	25	2	50	165	11	11	–	–	–
25	30	2	60	165	11	11	–	–	–
30	40	2	80	165	11	11	2	50	29
40	50	2	100	192,5	11	11	2	60	29
50	60	2	120	192,5	12,5	11	2	60	29
60	70	2	140	192,5	12,5	11	2	80	29
70	80	2	160	220	14	12,5	2	100	34
80	90	2	180	220	14	12,5	2	100	37
90	100	2	210	220	16	14	2	110	37
100	110	2	240	220	16	14	2	110	39
110	120	2	270	247,5	17,5	16	2	110	39
120	130	2	300	247,5	17,5	16	2	110	44
130	140	2	340	275	19	17,5	2	120	44
140	150	2	390	275	19	17,5	2	120	49
150	175	2	480	275	22	19	2	120	54
175	205	2	570	302,5	24	20,5	2	120	59
205	240	2	660	302,5	26	22	2	120	64
240	280	2	780	330	28	24	3	120	71
280	320	2	900	357,5	30	26	3	140	78
320	360	2	1020	357,5	32	28	3	140	86
360	400	2	1140	385	34	30	3	140	93
400	450	2	1290	385	36	32	3	140	101
450	500	2	1440	412,5	38	34	3	140	108
500	550	2	1590	412,5	40	34	4	160	113
550	600	2	1740	440	42	36	4	160	118
600	660	2	1920	440	44	38	4	160	123
660	720	2	2100	440	46	40	4	160	127

(1) The mooring lines are given as a guidance, but are not required as a condition of classification.

7.2.2 Anchors

The required mass for each anchor is to be obtained from Tab 2.

The individual mass of a main anchor may differ by $\pm 7\%$ from the mass required for each anchor, provided that the total mass of anchors is not less than the total mass required in Tab 2.

The mass of the head of an ordinary stockless anchor, including pins and accessories, is to be not less than 60% of the total mass of the anchor.

Where a stock anchor is provided, the mass of the anchor, excluding the stock, is to be not less than 80% of the mass required in Tab 2 for a stockless anchor. The mass of the stock is to be not less than 25% of the mass of the anchor without the stock but including the connecting shackle.

7.2.3 Scantlings of stud link chain cables

The mass and geometry of stud link chain cables, including the links, are to be in compliance with the requirements in NR 216 Materials, Ch 4, Sec 1, [2].

The diameter of stud link chain cables is to be not less than the value in Tab 2.

7.2.4 Chain cable arrangement

Chain cables are to be made by lengths of 27,5 m each, joined together by Dee or lugless shackles.

The total length of chain cables, as required in Tab 2, is to be divided into approximately equal parts between the two anchors ready for use.

Where different arrangements are provided, they are to be considered by the Society on a case-by-case basis.

When chain cables are replaced by trawl warps, the anchor is to be positioned on the forecastle deck so that it may be readily cast after it has been shackled to the trawl warp. Chocks or rollers are to be fitted at suitable locations, along the path of the trawl warps, between the winch and the mooring chocks.

8 Protection of hull metallic structures

8.1 Protection of cargo sides by battens

8.1.1 In cargo spaces, where thermal insulation is fitted, battens formed by spaced planks are generally to be fitted longitudinally.

8.2 Deck composition

8.2.1 The deck composition is to be of such a material as to prevent corrosion as far as possible and is to be effectively secured to the steel structures underneath by means of suitable connections.

Section 4 Machinery

1 General

1.1 Application

1.1.1 Machinery systems fitted on board ships having the notation **fishing vessel** are to comply with the relevant sections of Part C, Chapter 1, with the exception of tests and the following systems:

- bilge system
- scuppers and sanitary discharges
- air pipes and sounding devices
- ventilation
- oil fuel systems
- cooling systems
- lubricating oil systems
- compressed air systems
- hydraulic systems
- exhaust gas system
- refrigerating installations
- propelling and auxiliary machinery
- steering gear,

for which substitutive requirements are provided in this Section.

1.1.2 This Section does not cover the design and performances of the fishing equipment. However, the piping systems and pressure vessels serving the fishing equipment are required to comply with the relevant Sections of Part C.

1.2 Documents to be submitted

1.2.1 In addition to the documents listed in Tab 1 and Tab 2, the diagram of the piping systems (hydraulic system, etc.) serving the fishing equipment is to be submitted for approval.

Table 1 : Documents to be submitted

No.	Document (1)
1	Drawing showing the arrangement of the sea chests and ship side valves
2	Diagram of the bilge and ballast systems (in and outside machinery spaces)
3	Specification of the central priming system intended for bilge pumps, when provided
4	Diagram of the scuppers and sanitary discharge systems
5	Diagram of the air, sounding and overflow systems
6	Diagram of cooling systems (sea and fresh waters)
7	Diagram of fuel oil system
8	Drawings of the fuel oil tanks not forming part of the ship's structure
9	Diagram of the lubricating oil system
10	Diagram of the thermal oil system
11	Diagram of the hydraulic systems intended for essential services or located in machinery spaces
12	Diagram of the compressed air system
13	Diagram of the hydraulic and pneumatic remote control systems
14	Diagram of the exhaust gas system
15	Diagram of drip trays and gutterway draining system
16	Arrangement of the ventilation system
(1) To be submitted for approval. Diagrams are also to include, where applicable, the (local and remote) control and monitoring systems and automation systems.	

Table 2 : Information to be submitted

No.	I/A (1)	Document
1	I	Nature, service temperature and pressure of the fluids
2	A	Material, external diameter and wall thickness of the pipes
3	A	Type of the connections between pipe lengths, including details of the weldings, where provided
4	A	Material, type and size of the accessories
5	A	For plastic pipes: <ul style="list-style-type: none"> • the chemical composition • the physical and mechanical characteristics in function of temperature • the characteristics of inflammability and fire resistance • the resistance to the products intended to be conveyed
(1) A = to be submitted for approval ; I = to be submitted for information		

1.3 Tests - Trials in ships L ≥ 24 m

1.3.1 See Part C, Chapter 1.

1.4 Tests - Trials in ships L < 24 m

1.4.1 General

The building and fitting of fluid systems, pumps, pipes and their accessories, as well as other installations referred to in this Chapter are to be attended by a Society's Surveyor, at the Builder's request.

Pneumatic tests are to be avoided whenever possible. When such testing is essential in lieu of hydraulic pressure test, procedure for testing is to be submitted to the Society for acceptance prior to testing.

1.4.2 Testing on board

After assembly onboard, all fittings and accessories being fitted, a hydraulic pressure test is to be carried out for compressed air and oil fuel pipes.

As a rule, the test pressure is not to be less than 1,5 times the service pressure.

1.4.3 Hydraulic tests of oil fuel bunkers, tanks and accessories

The oil fuel bunkers and tanks not forming part of the ship's structure are to be submitted to a hydraulic test under a pressure corresponding to the maximum liquid level in these spaces or in the air or overflow pipes, subject to a minimum of 2,40 m above the top. This minimum height is to be 3,60 m for tanks intended to contain oil fuel having a flash point below 60°C.

Non metallic or metallic flexible pipes and expansion joints are to be tested in accordance with the requirements stated in [1.10.4] item e) and [1.11.7] item a), as appropriate.

1.5 General requirements applicable to all piping systems in ships L ≥ 24 m

1.5.1 See relevant requirements of Pt C, Ch 1, Sec 10, [1] and Pt C, Ch 1, Sec 10, [5].

1.6 General requirements applicable to all piping systems in ships L < 24 m

1.6.1 Materials

The manufacturer's test certificate for materials for valves and fittings can be accepted in lieu of the Society's materials certificate where the maximum conditions are not beyond those shown in Tab 3.

Table 3 : Maximum conditions for acceptance of manufacturer's test certificate

Material	Maximum conditions
Spheroidal or nodular cast iron	DN < 50 and PxDN < 2500
Carbon and low alloy steel	-10°C < t < 300°C and DN < 50, or -10°C < t < 300°C and PxDN < 2500
Cupreous alloy (1)	t < 200°C and DN < 50, or t < 200°C and PxDN < 1500
(1) See Pt C, Ch 1, Sec 10, [2.1]. Note 1: DN = nominal diameter, P = working pressure, t = working temperature.	

1.6.2 Fixing and arrangement of the pipes

- a) Except where otherwise permitted, piping and pumping systems covered by this Chapter are to be permanently fixed onboard ship.
- b) Unless otherwise specified, the fluid lines referred to in this Chapter are to consist of pipes connected to the ship's structure by means of collars or similar devices.
- c) As far as possible, pipes are not to pass near switchboards or other electrical apparatuses. If this requirement is impossible to satisfy, gutterways or masks are to be provided wherever deemed necessary to prevent projections of liquid on live parts.
- d) These provisions also apply to the exhaust pipes of internal combustion engines.

1.6.3 Protection of pipes

Pipes are to be efficiently protected against corrosion particularly in their most exposed parts, either by selection of their constituent materials, or by an appropriate coating or treatment.

1.6.4 Accessories

Locks, valves and other accessories are generally to be so placed that they are easily visible and accessible for manoeuvring, control and maintenance.

1.7 Sea inlets and overboard discharges in ships $L \geq 24$ m

1.7.1 See Pt C, Ch 1, Sec 10, [2.8].

1.8 Sea inlets and ship side valves in ships $L < 24$ m

1.8.1 Valves

All sea inlet and outlet pipes are to be provided with valves fixed:

- directly on the plating, or
- on steel chests built on the plating, or
- on strong distance pieces as short as possible which may be welded to the plating.

1.8.2 Strainers

Sea inlets are to be fitted with strainers. The flow section through each strainer is not to be less than twice the total section of the suction pipes connected to the said inlet.

1.8.3 Materials

The valves on sea inlets and overboard discharges are to be of steel or appropriate non-brittle material.

Similar provisions apply to distance pieces connecting the valves to the shell plating.

1.8.4 Protection against corrosion

Efficient arrangements such as the fitting of zinc anodes are to be made in order to protect the steel parts of sea inlets and discharges against corrosion.

1.9 Non-metallic rigid pipes in ships $L \geq 24$ m

1.9.1 See Pt C, Ch 1, App 3.

1.10 Non-metallic rigid pipes in ships $L < 24$ m

1.10.1 General

- a) The Society may permit the use of rigid pipes made of plastics in lieu of metallic pipes in the conditions specified in [1.10.2], [1.10.3] and [1.10.4].
- b) These requirements apply to thermoplastic materials but, where appropriate, may also be applied to pipes manufactured in fibre reinforced thermosetting resins.
- c) For every application, characteristics of the proposed plastics are to be given to the Society, namely:
 - the chemical composition
 - the physical and mechanical characteristics in function of the temperature
 - the fire properties
 - eventually, the resistance to the various products likely to come into contact with those plastics.

1.10.2 Use of plastic pipes

- a) Pipes made of plastics are permitted, as a general rule, for:
 - scupper and sanitary discharge pipes
 - ballast pipes except for the parts passing through engine rooms, dangerous spaces and oil fuel bunkers or located between pumps and their suction and discharges
 - individual bilge pipes for small compartments such as chain lockers.
- b) For other pipes such as air and sounding pipes of compartments not intended to contain oil fuel, the Society may accept the use of plastics subject to an examination of the relevant drawings.
- c) Pipes made of plastics may be used for fluid systems not covered by the classification provided the requirements given in [1.10.3] are complied with.
- d) Pipes made of plastics are not to be used where they are subject to temperatures above 60°C or below 0°C.
The use at a higher temperature for particular applications is subject to special examination.
- e) Any proposed service for plastic pipes not mentioned above is to be submitted to the Society for special consideration.

1.10.3 Intactness of watertight subdivision and fire divisions

- a) As a rule, pipes made of plastics cannot pass through watertight bulkheads.
- b) If, however, such a passage cannot be avoided, arrangements are to be made in order to ensure the integrity of the subdivision in case of pipe breakage. Such arrangements are to be submitted to the Society.
- c) The use of pipes made of plastics is generally to be avoided wherever the destruction of these pipes in case of fire would compromise the intactness of subdivision or the safety of the ship.
- d) Where pipes made of plastics are to pass through fire divisions, the arrangements taken to ensure the fire integrity of these divisions are to be submitted to the Society.

1.10.4 Design and construction

- a) Pipes and fittings are to be of a robust construction and are to comply with the requirements of such national standards as may be consistent with their intended use.
Particulars of scantlings and joints are to be submitted for examination.
- b) All pipes are to be adequately but freely supported. Suitable provision for expansion and contraction is to be made in each range of pipes to allow for important clearance between pipes made of plastics and steel structures, in consideration of the difference between their individual coefficients of thermal expansion.
- c) All fittings and branches are to be suitable for the intended service and are to have joints of cemented, flanged or other approved types.
- d) The bursting pressure of pipes, fittings and joints made of plastics, at their service temperature, is not to be less than 4 times their maximum service pressure, with a minimum of 5 bar.
- e) After completion, pipes and fittings are to be subjected to a hydraulic pressure test, to be applied during at least 5 minutes under a pressure not less than 1,5 times the service pressure.

1.11 Flexible hoses and expansion joints

1.11.1 General

- a) The Society may permit the use of flexible hoses and expansion joints, both in metallic and non-metallic materials, provided they are approved for the intended service.
- b) Flexible hoses and expansion joints are to be of a type approved by the Society, designed in accordance with [1.11.3] and tested in accordance with [1.11.6].
- c) Flexible hoses and expansion joints are to be installed in accordance with the requirements stated in [1.11.5].
- d) Flexible hoses and expansion joints intended for piping systems with a design temperature below the ambient temperature will be given special consideration by the Society.

1.11.2 Documentation

The information, drawings and documentation listed in [1.2.1], Tab 1 and Tab 2 are to be submitted to the Society for each type of flexible hose or expansion joint intended to be used.

1.11.3 Design of flexible hoses and expansion joints

- a) Flexible pipes and expansion joints are to be made of materials resistant to the marine environment and to the fluid they are to convey. Metallic materials are to comply with Pt C, Ch 1, Sec 10, [2.1.2].

- b) Flexible pipes and expansion joints are to be designed so as to withstand:
 - external contact with hydrocarbons
 - internal pressure
 - vibrations
 - pressure impulses.
- c) Flexible pipes intended to convey fuel oil or lubricating oil and end attachments are to be of fire-resisting materials of adequate strength and are to be constructed to the satisfaction of the Society.
- d) Where a protective lining is provided for this purpose, it is to be impervious to hydrocarbons and to hydrocarbon vapours.
- e) Flexible pipes intended to convey:
 - gaseous fluid at a pressure higher than 1 MPa
 - fuel oil or lubricating oil,are to be fitted with a metallic braid.
- f) As a general rule, flexible hoses are to be fitted with crimped connections or equivalent. For water pipes subject to a pressure not exceeding 0,5 MPa, as well as for scavenge air and supercharge air lines of internal combustion engines, clips made of galvanised steel or corrosion-resistant material with thickness not less than 0,4 mm may be used.
- g) Flexible pipes and expansion joints are to be so designed that their bursting pressure at the service temperature is not less than 4 times their maximum service pressure, with a minimum of 2 MPa. Exemptions from this requirement may be granted for expansion joints of large diameter used on sea water lines.
- h) The junctions of flexible hoses and expansion joints to their couplings are to withstand a pressure at least equal to the bursting pressure defined in item f).

1.11.4 Conditions of use of flexible hoses and expansion joints

- a) The use of flexible hoses and expansion joints is to be limited as far as practicable.
- b) The position of flexible hoses and expansion joints is to be clearly shown on the piping drawings submitted to the Society.
- c) The use of non-metallic expansion joints on pipes connected to sea inlets and overboard discharges is to be given special consideration by the Society. As a rule, the fitting of such joints between the ship side and the valves mentioned in Pt C, Ch 1, Sec 10, [2.8.3] or [1.8.1], as applicable, is not permitted. Furthermore, unless the above-mentioned valves are fitted with remote controls operable from places located above the freeboard deck, efficient means are to be provided, wherever necessary, to limit the flooding of the ship in the event of rupture of the expansion joints.
- d) Expansion joints may be fitted in sea water lines, provided they are arranged with guards which effectively enclose, but do not interfere with, the action of the expansion joints and reduce to the minimum practicable any flow of water into the machinery spaces in the event of failure of the flexible elements.
- e) Use of expansion joints in water lines for other services, including ballast lines in machinery spaces, in duct keels and inside double bottom water ballast tanks, and bilge lines inside double bottom tanks and deep tanks, is to be given special consideration by the Society.

1.11.5 Arrangement of flexible hoses and expansion joints

- a) Flexible hoses and expansion joints are to be so arranged as to be accessible at all times.
- b) Flexible hoses and expansion joints are to be as short as possible.
- c) The radius of curvature of flexible hoses is not to be less than the minimum recommended by the manufacturer.
- d) The adjoining pipes are to be suitably aligned, supported, guided and anchored.
- e) Isolating valves are to be provided permitting the isolation of flexible hoses intended to convey flammable oil or compressed air.
- f) Expansion joints are to be protected against over extension or over compression.
- g) Where they are likely to suffer external damage, flexible hoses and expansion joints of the bellows type are to be provided with adequate protection.

1.11.6 Type tests of flexible hoses and expansion joints

- a) Type approval tests are to be carried out on a flexible hose or an expansion joint of each type and each size, in accordance with Tab 4.
- b) The flexible pipes or expansion joints subjected to the tests are to be fitted with their connections.
- c) The fire-resistance test is to be carried out in the conditions hereafter; other test methods may be applied after special examination.

The flexible pipe is to be subjected to fire for 30 minutes at a temperature of 800°C, while water at the maximum service pressure is circulated inside the pipe; the temperature of the water at the outlets is not to be less than 80°C. No leak is to be recorded during and after the test.
- d) Flexible pipes or expansion joints granted with a type approval certificate issued by the Society for the intended conditions of use are exempted from type-tests.

1.11.7 Hydraulic tests

- a) Each flexible pipe or expansion joint, together with its connections, is to undergo a hydraulic test under a pressure at least equal to twice the maximum service pressure, subject to a minimum of 10 bar.
- b) During the test, the pipe or expansion joint is to be repeatedly deformed from its geometrical axis.

1.11.8 Marking

Each flexible pipe or expansion joint is to be stencilled or otherwise marked with its specified maximum service pressure and, when used in other than ambient temperature, its maximum or minimum service temperature or both.

Table 4 : Type tests to be performed for flexible hoses and expansion joints

Type test	Required
Bursting	Yes
Fire-resistance	Yes (1)
Vibration	Yes (2)
Pressure impulse	Yes
Flexibility	Yes (3)
Cyclic expansion	Yes (4)
Resistance	Yes (5)
(1) Only for flexible hoses and expansion joints used in flammable oil and sea water systems. (2) Only for flexible hoses and expansion joints fitted to engines, pumps, compressors or other sources of high vibrations. (3) Only for flexible hoses conveying low temperature fluids. (4) Only for piping systems subjected to expansion cycles. (5) Internal to the conveyed fluid and external to UV.	

1.11.9 Periodical replacement - Spare parts

- a) Flexible pipes or expansion joints are to be periodically replaced according to the periodicity depending on their types.
- b) A spare is recommended for each type of flexible pipe or expansion joint the failure of which could impair the operation of main engines, that of auxiliary engines for essential services or the safety of the ship.

1.12 Metallic flexible pipes and joints

1.12.1 Metallic flexible pipes and joints are to comply with the requirements stated in [1.11], as far as applicable. Fire-resistance tests need not be carried out.

2 Bilge system in ships L ≥ 24 m

2.1 General

2.1.1 Application

The following provisions supersede those given in Pt C, Ch 1, Sec 10, [6].

2.1.2 Principle

- a) Fishing vessels are to be provided with an efficient bilge pumping system capable of pumping from and draining, under all practical conditions, any watertight compartment other than spaces exclusively intended for the carriage of fresh water, water ballast or fuel oil, for which other efficient means of pumping are to be provided.
- b) In fishing vessels where fishing handling or processing may cause quantities of water to accumulate in enclosed spaces, adequate drainage is to be provided.
- c) The bilge pumping system is to consist of pumps connected to a bilge main line so arranged as to allow the draining of all spaces mentioned in item a).
- d) Bilge pumping arrangement may be dispensed with in particular compartments where no equipment nor openings are likely to leak.
- e) Where expressly permitted, some small compartments may be drained by means of hand pumps.
- f) Bilge and ballast systems are to be so designed as to prevent the possibility of water passing from the sea and from water ballast spaces into the cargo and machinery spaces, or from one compartment to another. Provisions are to be made to prevent any space having bilge and ballast connections being inadvertently flooded from the sea when containing cargo, or being discharged through the bilge system when containing water ballast.
- g) Where there are common valves between bilge and fire fighting lines, they are to have a locked device on his handwheels in order to avoid the discharge of bilge water into the fighting circuit.

2.2 Design of the bilge system

2.2.1 General

- a) All suction pipes up to the connection with the bilge pumps are to be independent from any other piping system of the ship.
- b) Non-return valves are to be fitted on:
 - direct and emergency suction in machinery spaces
 - the pipe connections to bilge distribution boxes
 - the suction of pumps having also connections from the sea or from compartments normally intended to contain liquid
 - the direct suction connected to independent bilge pumps, where required.
- c) All compartments are to be provided with at least one suction on each side. However, in the case of short and narrow compartments, a single suction ensuring an efficient draining may be accepted.

2.2.2 Draining of machinery spaces

- a) Machinery spaces of ships with double bottom, or where the rise of floor is less than 5°, are to be provided on each side with one bilge suction connected to the bilge main.
- b) Machinery spaces of ships without double bottom, or where the rise of floor exceeds 5°, may be provided with only one bilge suction located in the centreline and connected to the bilge main.
- c) In addition to the bilge suction required in items a) and b), machinery spaces are to be provided with a direct suction, which is to be led direct to an independent power bilge pump and so arranged that it can be used independently of the bilge main.

2.2.3 Emergency bilge suction

- a) The emergency bilge suction is to be led directly from the drainage level of the machinery space to the greater capacity sea water pump. Its capacity is to be at least equal to the required capacity of each bilge pump as determined in [2.3.4].
- b) The emergency bilge suction is to be located at the lowest possible level in the machinery spaces.
- c) The diameter of emergency bilge suction pipes is to be at least the diameter of the suction connected to of the sea water pump in normal operation.
- d) The high of the hand-wheels of the non-return valves controlling emergency bilge suction are to rise at least 450 mm above the manoeuvring floor.
- e) If the requirement mentioned in d) can not be verified, the height of the hand-wheels of the non-return valves is to be the minimum height to permit the easy operation of the valve.

2.2.4 Draining of holds

- a) Holds of ships with double bottom, or where the rise of floor is less than 5°, are to be provided on each side with one bilge suction connected to the bilge main.
- b) Holds of ships without double bottom, or where the rise of floor exceeds 5°, may be provided with only one bilge suction located in the centreline and connected to the bilge main.
- c) Holds greater than 30 m in length, bilge suction are to be provided in the fore and aft ends and connected to the bilge main.

2.2.5 Draining of refrigerated spaces

Refrigerated spaces are to be provided with drainage arrangement allowing the continuous drainage of condensates.

2.2.6 Draining of fore and aft peaks

- a) Fore and aft peaks, where not used as tanks, are to be fitted with a bilge suction connected to the bilge main. Passage through the collision bulkhead is to comply with [2.5.2].
- b) Peaks of small dimensions may be drained by means of a hand pump provided that the suction lift is well within the capacity of the pump and in no case exceeds 7,30 m.

2.2.7 Draining of double bottom compartments

Double bottom compartments, where not used as tanks, are to be provided with bilge suction. Their number and location are to comply with the provisions of [2.2.4]. However, if deemed acceptable by the Society, the cofferdams fitted between two different compartments of the double bottom may be provided with one bilge suction only.

2.2.8 Draining of other compartments

- a) Provision is to be made for the drainage of chain lockers and other fore spaces by means of hand or power pump suction or hydraulic ejectors.
- b) Provision is to be made for the drainage of the steering gear compartment and other spaces located above the aft peak by means of suction connected to the bilge main or by means of hand pumps or hydraulic ejectors.
- c) These spaces may, however, be drained by means of scuppers discharging to the shaft tunnel, provided that the discharge pipes are fitted with self-closing valves situated in easily visible and accessible positions.

- d) Fish processing spaces are to be fitted with drainage means, the capacity of which is four times the normal feedwater flow in the space.

2.3 Bilge pumps

2.3.1 Number and arrangement of pumps

- a) Fishing vessels are to be provided with at least two power bilge pumps of the self-priming type connected to the bilge main and having the capacity required in [2.3.4]. One of these pumps may be driven by the propulsion machinery.
- b) Each bilge pump may be replaced by two or more pumps, provided that they are connected to the bilge main and that their total capacity is not less than that required in [2.3.4].
- c) One of the bilge pumps required in item a) may be replaced by a hydraulic ejector having the capacity required in [2.3.4] and connected to a high pressure water pump.
- d) Where permitted, hand pumps are to be operable from an easily accessible position above the load waterline.

2.3.2 Location of bilge pumps

Bilge pumps are to be located on the aft side of the collision bulkhead. This may not apply to those pumps only used for the draining of the spaces located on the fore side of the collision bulkhead.

2.3.3 Use of pumps intended for other duties

- a) Pumps used for sanitary service, general service or ballast may be considered as independent bilge pumps provided that:
 - they have the capacity required in [2.3.4]
 - they are of the self-priming type
 - they are connected to the bilge system.
- b) Non-return valves are to be provided in accordance with [2.2.1], item b).

2.3.4 Bilge pump capacity

- a) The water speed V in the bilge main and the capacity Q of each bilge pump are to be not less than the values given in Tab 5.
- b) If the capacity of one of the pumps is less than the rule capacity, the deficiency may be compensated by an excess capacity of the other pumps. Such deficiency is, however, not to exceed 30% of the rule capacity.

Table 5 : Water speed and pump capacity

Ship's length	L < 35	L ≥ 35
Water speed	V = 1,22	V = 2,00
Pump capacity	Q = 0,00345 d ²	Q = 0,00565 d ²
L : Length of the ship, in m V : Minimum water speed in the bilge main, in m/s Q : Minimum capacity of each pump, in m ³ /h d : Internal diameter of the bilge main, in mm, as defined in [2.4.1].		

2.4 Size of bilge pipes

2.4.1 Bilge main line

- a) The diameter of the bilge main is to be calculated according to the following formula:

$$d = 25 + 1,68\sqrt{L(B + D)}$$

without being less than 50 mm,

where:

- d : Internal diameter of the bilge main, in mm
- L : Length of the ship between perpendiculars, in m
- B : Breadth of the ship, in m
- D : Depth of the ship, measured up to the bulkhead deck, in m.

- b) The actual internal diameter may be rounded off. The nearest standard size is in no case to be more than 5 mm smaller than that obtained from the formula given in item a).

2.4.2 Branch bilge suction pipes

- a) The diameter of the pipes situated between the distribution boxes and the suction in the various spaces (holds, machinery space, etc) is to be calculated according to the following formulae:

$$d_1 = 25 + 2,16\sqrt{L_1(B + D)}$$

without being less than 50 mm,

where:

d_1 : Internal diameter of the suction pipe, in mm

L_1 : Length of the space considered, in m

L, B, D : Length, breadth and depth of the ship as defined in [2.4.1].

- b) The actual internal diameter may be rounded off. The nearest standard size is in no case to be more than 5 mm smaller than that obtained from the formula given in item a).

2.5 Bilge piping arrangement

2.5.1 Passage through double bottom compartments and tanks

Bilge pipes are not to pass through double bottom compartments or tanks unless they are enclosed in appropriate pipe tunnels. Where this is not practicable, pipes are to be of reinforced thickness as per Pt C, Ch 1, Sec 10, Tab 6 and made of either one piece or several pieces assembled by welding or by reinforced flanges.

2.5.2 Passage through the collision bulkhead

- a) A maximum of two pipes may pass through the collision bulkhead below the freeboard deck, unless otherwise justified. Such pipes are to be fitted with suitable valves operable from above the freeboard deck and the valve chest is to be secured at the bulkhead inside the fore peak. Such valves may be fitted on the after side of the collision bulkhead provided that they are readily accessible under all service conditions and the space in which they are located is not a cargo space. All valves are to be of steel, bronze or other approved ductile material. Valves of ordinary cast iron or similar material are not acceptable.
- b) The remote operation device of the valve referred to in a) is to include an indicator to show whether the valve is open or shut.

2.5.3 Bilge suction in machinery spaces and shaft tunnels

In machinery spaces and shaft tunnels, the termination pipes of the bilge suction are to be straight and vertical and are to be led to mud boxes so arranged as to be easily inspected and cleaned. The lower end of the termination pipe is not to be fitted with a strum box.

2.5.4 Bilge suction in other compartments

In compartments other than machinery spaces and shaft tunnels, the open ends of bilge suction pipes are to be fitted with strum boxes or strainers having holes not more than 10 mm in diameter. The total area of such holes is not to be less than twice the required cross-section of the suction pipe.

2.5.5 Bilge alarms

Propulsion machinery spaces are to be fitted with a bilge level sensor capable of indicating water ingress in those spaces at the bridge by means of a visual and audible alarm.

2.6 Materials

2.6.1 All bilge pipes used in fuel storage tanks or in boiler or machinery spaces, including spaces in which oil-setting tanks or fuel oil pumping units are situated, are to be of steel or other suitable material non-sensitive to heat.

3 Bilge system in ships $L < 24$ m

3.1 General

3.1.1 Principle

All ships are to be provided with efficient means for pumping and draining any watertight space with at least one suction pipe when the ship is on an even keel and either is upright or has a list of up to 5°.

3.1.2 Independence of the lines

As a general rule, bilge lines are to be distinct from the other lines of the ship.

However, this requirement need not be applied to pipes located between collecting boxes and pump suction or between pumps and overboard discharges.

3.1.3 Intactness of watertight subdivision

The lines and accessories are to be so arranged as to prevent intercommunication of compartments which are to remain segregated from each other or the accidental connection of these compartments directly to the sea.

3.1.4 Bilge main

A bilge main is to be provided for draining the different compartments for ships the length of which is greater than, or equal to, 12 m.

3.1.5 Number and distribution of suction

At least two bilge suction are to be provided for draining the propulsion engine room. At least one of these suction is to be connected directly to a bilge pump.

The suction are to be located at the lowest points of the compartment.

Additional suction may be required if the flow of water towards the suction is disturbed by irregularities of the bottom.

At least one bilge suction is to be provided in each compartment located between two watertight bulkheads.

3.2 Pumps and ejectors

3.2.1 Pumps

- a) At least two power bilge pumps are to be provided; one of these pumps may be driven by a main propulsive engine.
- b) The Society may permit, after special consideration, that one of the pumps be replaced by an ejector.
- c) For ships the length of which is greater than, or equal to, 12 m, the bilge pumps are to be connected to the bilge main mentioned in [3.1.4].
- d) For ships having the navigation notation **coastal area**, the Society may permit, after special consideration, that one of bilge pumps be a fixed hand pump.
- e) Small compartments may be drained by means of portable or fixed hand pumps.

3.2.2 Ejectors

Where an ejector is used in lieu of a driven pump, its suction capacity is not to be less than the required capacity of the pump it replaces.

3.2.3 Capacity of the pumps

The capacity of the bilge pumps is to be such that a speed of water not less than 1,22 m/s may be obtained in the bilge main, the diameter of which is given in [3.3.1]. The capacity of each pump is therefore not to be less than:

$$Q = 0,00345 d_1^2$$

where:

- Q : Minimum capacity of each pump, in m³/h
d₁ : Internal diameter, in mm, of the bilge main as defined in [3.3.1].

3.3 Size of bilge pipes

3.3.1 Bilge main

The internal diameter, in mm, of the bilge main, is to be of the commercial size nearest to the diameter given in the following formula:

$$d_1 = 25 + 1,68 \sqrt{L(B+C)}$$

without being less than 35 mm,

where:

- L, B : Rule length and breadth, respectively, of the ship, in m, defined in Pt B, Ch 1, Sec 3
C : Moulded depth of the ship, in m, at the freeboard deck.

3.3.2 Suction in holds and machinery spaces

The internal diameter, in mm, of bilge pipes situated between collecting boxes and suction in holds and machinery spaces, is to be of the commercial size nearest to the diameter given by the following formula:

$$d_2 = 25 + 2,16 \sqrt{L_1(B+C)}$$

without being less than 35 mm,

where:

- B, C : Dimensions having the same meaning as in [3.3.1]
L₁ : Length of the compartment, in m.

3.4 Arrangement of bilge lines and their accessories

3.4.1 Passage of pipes through certain compartments

If not contained in pipe tunnels, the part of bilge pipes passing through compartments intended to contain oil fuel are to have reinforced thickness and are to consist of a single piece. These pipes are to be provided with non-return valves at their ends in the holds.

3.4.2 Passage through watertight bulkheads

No bilge cock or similar device is to be fitted on the collision bulkhead.

The fitting of bilge cocks or similar devices on other watertight bulkheads is to be avoided as far as possible. However, where such accessories are provided, they are to be accessible at any time and capable of being closed from positions above the deck. An indication is to be provided to show whether these valves are open or close.

3.4.3 Non-return valves

Accessories are to be provided to prevent intercommunication of compartments or lines which are to remain segregated from each other. For this purpose, non-return valves or similar devices are to be fitted, namely on the pipe connections to bilge distribution boxes or to the alternative cocks, if any.

3.4.4 Strainers and mud boxes

Strainers and mud boxes are to be fitted on bilge lines wherever they are necessary.

4 Scuppers and sanitary discharges

4.1 Principle

4.1.1 Scuppers, sufficient in number and suitable in size, are to be provided to permit the drainage of water likely to accumulate in the spaces which are not located in the ship's bottom.

4.1.2 The number of scuppers and sanitary discharge openings in the shell plating is to be reduced to a minimum, either by making each discharge serve as many as possible of the sanitary and other pipes, or in any other satisfactory manner.

4.2 General

4.2.1 Discharges led through the shell either from spaces below the working deck or from within enclosed superstructures or deckhouses on the working deck fitted with weathertight doors are to be fitted with accessible means for preventing water from passing inboard.

4.2.2 Each separate discharge is to have an automatic non-return valve with a positive means of closing it from an accessible position, except when:

- satisfactory analysis is submitted to the Society, demonstrating that the entry of water into the vessel through the opening is not likely to lead to dangerous flooding, and
- the piping is of reinforced thickness as per Pt C, Ch 1, Sec 10, Tab 6.

4.2.3 The means for operating the positive action valve is to be provided with an indicator showing whether the valve is open or closed.

4.3 Discharges through manned machinery spaces

4.3.1 In manned machinery spaces, main and auxiliary discharges essential for the operation of machinery may be controlled locally. The controls are to be accessible and are to be provided with indicators showing whether the valves are open or closed.

4.4 Materials

4.4.1 Fittings attached to the shell and the valves required in [4.2.2] are to be of steel, bronze or other ductile material.

4.4.2 All pipes between the shell and the valves are to be of steel. However, in spaces other than machinery spaces of vessels constructed of material other than steel, the use of other materials may be permitted, subject to special consideration by the Society.

5 Air pipes and sounding devices in ships $L \geq 24$ m

5.1 Air pipes

5.1.1 General

Air pipes are to be fitted to all spaces which are not fitted with alternative ventilation arrangements.

Air pipes are to be so arranged and the upper part of compartments so designed that air or gas likely to accumulate in the said compartments can freely evacuate.

When only one air pipe is provided, it is not to be used as filling pipe.

5.1.2 Exposed parts of air pipes

Where air pipes to tanks and void spaces below deck extend above the working or the superstructure decks, the exposed parts of the pipes are to be of strength equivalent to the adjacent structures and fitted with the appropriate protection.

5.1.3 Means of closing

Openings of air pipes are to be provided with means of closing, permanently attached to the pipe or adjacent structure.

5.1.4 Height of air pipes

The height of air pipes above deck to the point where water may have access below is to be at least:

- 760 mm on the working deck, and
- 450 mm on the superstructure deck.

The Society may accept reduction of the height of an air pipe to avoid interference with the fishing operations.

5.1.5 Special arrangements for air pipes of flammable oil tanks

- a) Air pipes from fuel oil and thermal oil tanks are to discharge to a safe position on the open deck where no danger will be incurred from issuing oil or gases.

Where fitted, wire gauze diaphragms are to be of corrosion resistant material and readily removable for cleaning and replacement. The clear area of such diaphragms is not to be less than the cross-sectional area of the pipe.

- b) Air pipes of lubricating or hydraulic oil storage tanks not subject to flooding in the event of hull damage may be led to machinery spaces, provided that in the case of overflowing the oil cannot come into contact with electrical equipment, hot surfaces or other sources of ignition.
- c) The location and arrangement of vent pipes for fuel oil service, settling and lubrication oil tanks are to be such that, in the event of a broken vent pipe, there is no risk of ingress of seawater or rainwater.
- d) Where seawater or rainwater may enter fuel oil service, settling and lubrication oil tanks through broken air pipes, arrangements such as water traps with:
- automatic draining, or
 - alarm for water accumulation,
- are to be provided.

5.1.6 Construction of air pipes

- a) Where air pipes to ballast and other tanks extend above the freeboard deck or superstructure deck, the exposed parts of the pipes are to be of substantial construction, with a minimum wall thickness of at least:

- 6,0 mm for pipes of 80 mm or smaller external diameter,
- 8,5 mm for pipes of 165 mm or greater external diameter.

Intermediate minimum thicknesses may be determined by linear interpolation.

- b) Air pipes with height exceeding 900 mm are to be additionally supported.
- c) In each compartment likely to be pumped up, and where no overflow pipe is provided, the total cross-sectional area of air pipes is not to be less than 1,25 times the cross-sectional area of the corresponding filling pipes.
- d) The internal diameter of air pipes is not to be less than 50 mm, except for tanks of less than 2 m³.

5.2 Sounding and level gauging devices

5.2.1 General

Sounding devices are to be fitted:

- to the bilges of those compartments which are not readily accessible at all times during voyages, and
- to all tanks and cofferdams.

5.2.2 Termination of sounding pipes

Where sounding pipes are fitted, their upper ends are to extend to a readily accessible position and, where practicable, above the working deck.

5.2.3 Means of closing

The openings of the sounding pipes are to be provided with permanently attached means of closing. Sounding pipes which are not extended above the working deck are to be fitted with automatic self-closing devices.

5.2.4 Special arrangements for sounding pipes of flammable oil tanks

Where tanks containing fuel oil or hydraulic oil are fitted with sounding pipes, their upper ends are to terminate in safe positions and are to be fitted with suitable means of closure.

Gauges made of heat-resistant glass of substantial thickness and protected with a metal case may be used, provided that automatic closing valves are fitted. The level gauge is to be of an approved type. Other means of ascertaining the amount of oil contained in the tank may be permitted provided their failure or overfilling will not permit release of fuel.

5.2.5 Construction of sounding pipes

- a) Sounding pipes are normally to be straight. If it is necessary to provide bends in such pipes, the curvature is to be as small as possible to permit the ready passage of the sounding apparatus.
- b) Bent portions of sounding pipes are to have reinforced thickness and be suitably supported.
- c) The internal diameter of sounding pipes is not to be less than 32 mm. Where sounding pipes pass through refrigerated spaces, or through the insulation of refrigerated spaces in which the temperature may be below 0°C, their internal diameter is to be at least 60 mm.
- d) Doubling plates are to be placed under the lower ends of sounding pipes in order to prevent damage to the hull. When sounding pipes with closed lower ends are used, the closing plate is to have reinforced scantlings.

6 Air pipes and sounding devices in ships L < 24 m

6.1 Air pipes

6.1.1 General

Air pipes are to be fitted to all compartments intended to contain liquid or which are not fitted with alternative ventilation arrangements.

These air pipes are to be so arranged as to be self-draining when the ship is on an even keel.

6.1.2 Number and position of air pipes

Air pipes are to be so arranged and the upper part of compartments so designed that air or gas likely to accumulate in the said compartments can freely evacuate.

When only one air pipe is provided, it is not to be used as filling pipe.

6.1.3 Tank air pipes

Air pipes of compartments likely to contain liquid hydrocarbons, cofferdams or any capacity likely to be pumped up are to be led out, at a sufficient height above the deck.

Air pipes of all compartments which can be run up from the sea are to be led to above the deck.

Moreover, air pipes of compartments containing liquid hydrocarbons are not to be led to a place where danger could be the consequence of the evacuation of hydrocarbons or hydrocarbon vapours through these openings.

Air pipes of lubricating oil tanks and bunkers may be led to the machinery spaces, provided that in case of overflow the oil cannot come into contact with electrical apparatus or with surfaces likely to be at a high temperature.

6.1.4 Open ends of air pipes

Efficient, permanently attached devices are to be provided permitting, should the necessity arise, to close the upper openings of air pipes in order to prevent any accidental entry of water into the spaces concerned.

Where the tank venting system is not of an automatic type approved by the Society, provision is to be made for relieving vacuum when the tanks are being pumped out, and for this purpose a hole of about 10 mm in diameter in the bend of the air pipe, or at a suitable position in the closing device, is acceptable.

6.1.5 Construction

In each compartment likely to be pumped up, and where no overflow pipe is provided, the total cross-sectional area of air pipes is not to be less than the cross-sectional area of the corresponding filling pipes.

6.2 Sounding and level gauging devices

6.2.1 General

Arrangements are to be made for sounding the tanks intended to contain liquid as well as all the compartments which are not readily accessible at all times.

6.2.2 Upper ends of sounding pipes

As a general rule, the sounding pipes are to end above the deck in easily accessible places and are to be fitted with efficient closing appliances.

However, in machinery spaces, when this requirement cannot be met, short sounding pipes may be used which are to lead to readily accessible positions above the floor and fitted with efficient closing appliances. When such sounding pipes are used for oil fuel or lubricating oil tanks, they are not to end close to electric motors or switchboards and are to be fitted with automatic closing devices.

6.2.3 Construction

- a) Internal diameter of sounding pipes is not to be less than 30 mm.
- b) Doubling plates are to be placed under the lower ends of sounding pipes in order to prevent damage to the hull.

6.2.4 Level-indicator systems

- a) Level-indicator systems are to be of robust construction and suitably protected.
- b) When used on fuel tanks or bunkers, level-indicator systems are to meet the requirements stated in [12.1.4].

7 Ventilation in ships ≥ 24 m

7.1

7.1.1 See Pt C, Ch 1, Sec 1, [3.1.1] and Pt C, Ch 1, Sec 1, [3.6.1].

See also Pt C, Ch 4, Sec 2, [2.1] and Pt C, Ch 4, Sec 6, [4].

8 Ventilation in ships < 24 m

8.1

8.1.1 Adequate ventilation is to be provided for spaces containing engines, boilers or other heat generating apparatuses, as well as for spaces where flammable vapours are likely to accumulate.

8.1.2 Ventilators serving the machinery spaces are to be capable of being closed in case of fire, from outside the said spaces. Skylights and other openings serving these spaces are to meet the following requirements:

- The skylights containing wire-reinforced glass panels are to be fitted with external shutters of steel or other equivalent material permanently attached
- Insulating materials in accommodation spaces, service spaces, control stations and machinery spaces except in refrigerated compartments are to be non-combustible. The surface of insulation fitted on the internal boundaries of machinery spaces is to be impervious to oil or oil vapours.

8.1.3 Ventilation of spaces containing propulsive plant and its auxiliaries is to be mechanical.

8.1.4 Mechanical ventilating fans are to be capable of being stopped from outside the space supplied by these ventilating fans.

9 Engine cooling systems in ships $L \geq 24$ m

9.1

9.1.1 See Pt C, Ch 1, Sec 10, [10].

10 Engine cooling systems in ships $L < 24$ m

10.1 Principle

10.1.1

- a) Provision is to be made so that the cooling of main engines and of lubricating oil or fresh water coolers for these engines can be suitably ensured in all normal operating conditions.
- b) Generally, cooling water to propulsion engines and to lubricating oil or fresh water coolers is to be capable of being supplied by two separate means.
- c) Engine cooling systems in ships having several propulsion engines are to be given special consideration by the Society.

10.2 Motorships

10.2.1

- a) The second means stated in [10.1.1] item b) for engine cooling may consist of a satisfactory connection to a general service pump of sufficient capacity.
- b) Where the power per engine does not exceed 370 kW or when the ratio of the power per engine expressed in kW to the rotating speed in revolutions per minute does not exceed 0,75, the Society may permit that the second means be a spare pump ready to be connected to the cooling system. Provision is to be made for the corresponding disassembling and reassembling operations to be carried out on board in a time as short as possible.

10.3 Fresh water cooling system

10.3.1 Where the engines are cooled by fresh water, the second means stated in [10.1.1] item b) may be omitted if a connection is fitted from the fresh water system to a suitable salt water system.

10.4 Cooling pumps

10.4.1 The pumps which may be connected to cooling systems may be either independent or driven by the machine they serve. Relief valves are to be fitted on the discharge of cooling pumps driven by main engines, except for centrifugal type pumps.

10.5 Sea inlets

10.5.1

- a) Not less than two sea inlets are to be provided for the engine cooling system. These sea inlets are to be distinct for the two means of cooling given in [10.1.1] item b), but they may be cross connected by a cross pipe.
- b) These sea inlets are to be low inlets and one of them may be that of the ballast pump or of the general service pump. A sea-inlet is considered as low provided it remains submerged under all normal navigating conditions.

10.6 Filters

10.6.1 Where propulsive engines are directly cooled by sea water, either in normal service or in emergency, filters are to be fitted on the suction of cooling pumps.

10.7 Operating control

10.7.1 Means are to be provided for controlling the temperature and the water circulation of each engine.

10.8 Materials

10.8.1 The materials used for cooling systems are to be such as to limit the effects of galvanic corrosion and erosion, considering the circulation speeds adopted.

11 Oil fuel systems in ships $L \geq 24m$

11.1

11.1.1 See Pt C, Ch 1, Sec 10, [11].

12 Oil fuel systems in ships $L < 24m$

12.1 General

12.1.1 Scope

The requirements stated in [12.1] and [12.2] are applicable to oil fuel systems for the service of propulsion engines and auxiliary machines. The flash point of the oil fuel used, determined by means of closed cup test, is not to be lower than 60°C.

The use for propulsion engines and auxiliary machine of oil fuel having a flash point lower than 60°C is subject to a special examination by the Society.

12.1.2 Pump controls

The power supply to oil fuel transfer pumps and to other pumps of the oil fuel system as well as to oil fuel separators is to be capable of being stopped from an always accessible place in the event of fire within the compartment where this equipment is located.

12.1.3 Drip-trays and gutterways

Drip-trays or gutterways with appropriate discharge devices are to be fitted:

- under pumps, valves and filters
- under oil fuel tanks and bunkers which are not part of the ship's structure, as well as
- under all the accessories subject to oil fuel leakage.

12.1.4 Level indicators

- a) Gauge cocks for checking the level in the tanks are not to be used.

The glasses of any level indicator fitted on such tanks are to be made of heat-resistant material and are to be efficiently protected against shock. Such level indicators are to be fitted with self-closing cocks at their lower end as well as at their upper end if the latter is below the maximum liquid level.

- b) Where the fuel transfer system does not include power pumps but only hand pumps, the valves to be provided at the lower end of level-indicators for fuel tanks, with the exception of daily service tanks, need not to be of the self-closing type. These valves are however to be readily accessible and instruction plates are to be fitted near these valves specifying that they are to be maintained closed except during transfer operations.

12.2 Oil fuel tanks and bunkers

12.2.1 Location of oil fuel tanks and bunkers

- a) Location of oil fuel tanks and bunkers is to be chosen in a way to avoid any abnormal rise in temperature in these capacities.
- b) The use of free standing oil fuel tanks is not permitted in high fire risk areas.

12.2.2 Suctions and discharges to oil fuel tanks and bunkers

- a) All suction pipes to oil fuel tanks and bunkers, including those in double bottom, are to be provided with valves.

In the case of bunkers and oil fuel storage, settling or daily service tanks other than those in the double bottom, the valves are to be fitted directly on the plating of these bunkers and tanks and are to be so arranged that they can always be remotely closed in the event of fire taking place in the compartment where they are located.

- b) Where the oil fuel transfer installation does not include power pumps but only hand pumps, the suction valves to oil fuel tanks and bunkers, with the exception of daily service tanks, need not to be provided with remote controls. These valves are however to be readily accessible and instruction plates are to be fitted in their vicinity specifying that they are to be maintained closed except during transfer operations.
- c) Where the discharge pipes to oil fuel bunkers and tanks are not led to the upper part of the said bunkers and tanks, they are to be provided with non-return valves at their ends.

12.2.3 Drains

Daily service tanks are to be provided with drains permitting the evacuation of water and impurities likely to accumulate in the lower part of these tanks. These drains are to be fitted with self-closing valves or cocks.

12.2.4 Materials - Tests

- a) The use of materials other than steel for fuel bunkers and tanks which are not part of the ship's structure is specially examined.
- b) Oil fuel tanks and bunkers are to be tested under the conditions specified in [1.4.3].

12.3 Transfer pipes

12.3.1 Arrangement of the transfer system

The transfer system together with its accessories are to be so arranged that oil fuel cannot enter compartments the structure of which does not allow them to be filled with oil fuel or compartments intended to contain drinking water.

12.3.2 Transfer pumps

Where oil fuel is transferred by means of a power pump, arrangements are to be made so that oil fuel may be pumped, in the event of damage to this pump, by means of a stand-by pump, which can be a hand pump.

12.3.3 Passage through particular compartments

No fuel pipes are to pass through fresh water tanks and no fresh water pipes are to pass through fuel oil tanks.

12.4 Oil fuel supply to engines

12.4.1 The suctions of engine fuel pumps are to be so arranged as to prevent the suction of gathered water and sludge likely to accumulate after decanting at the lower part of service tanks.

12.4.2 Two filters, or similar devices, are to be provided and so arranged that one of the filters can be overhauled while the other is in use.

12.5 Materials - Construction

12.5.1 Low-pressure oil fuel pipes are generally to be made of steel. Where the internal diameter of these pipes does not exceed 25 mm, they may be of seamless copper or copper-alloy unless they pass through oil fuel tanks.

12.5.2 Transfer oil fuel pipes may be of non metallic hoses in the conditions stated in [1.10].

12.5.3 The pipes are to be connected by means of close-fitting flanges or other devices deemed equivalent for the application considered. The materials of the joints are to be impervious to liquid hydrocarbons.

13 Lubricating oil systems in ships $L \geq 24$ m

13.1

13.1.1 See Pt C, Ch 1, Sec 10, [12].

14 Lubricating oil systems in ships $L < 24$ m

14.1 General

14.1.1 The lubricating oil systems are to be so arranged as to operate satisfactorily when the ship is inclined from the normal position to angles of up to 15° transversely or 5° longitudinally, or when rolling to angles of up to $22^\circ 30'$ or pitching up to $7^\circ 30'$. Lubricating oil pipes are to be independent of any other fluid system.

14.2 Lubricating pumps

14.2.1

- a) Main engines are normally to be provided with at least two power lubricating pumps. Where the installation includes at least two propulsive units, the Society may permit that only one pump be provided for each propulsive unit.
- b) Where the power per engine does not exceed 370 kW or when the ratio of the power per engine expressed in kW to the rotating speed in revolutions per minute does not exceed 0,75, the Society may permit that one of the pumps mentioned in item a) be a spare pump ready to be connected to the lubricating oil system. Provision is to be made for the corresponding disassembling and reassembling operations to be carried out on board in a time as short as possible.

14.3 Filters

14.3.1 In forced lubrication systems, a device is to be fitted which efficiently filters the lubricating oil in the circuit. The filters provided for this purpose are to be so arranged that they can be easily cleaned without stopping the lubrication of the machines.

14.4 Safety devices

14.4.1 Lubricating oil systems for propulsive engines are to be provided with an alarm device giving audible warning in the event of an appreciable reduction of the oil pressure.

15 Hydraulic systems in ships $L \geq 24$ m

15.1

15.1.1 See Pt C, Ch 1, Sec 10, [14].

16 Hydraulic systems in ships $L < 24$ m

16.1 General

16.1.1 Installations using flammable oils are to be given special consideration by the Society.

16.2 Safety and monitoring devices

16.2.1 Whenever practicable, the hydraulic power units are to be located outside the main engine or boiler rooms. Shields or similar devices are to be provided around the hydraulic power units in order to avoid accidental oil spray or oil mist on heated surfaces which may ignite oil.

17 Compressed air systems in ships $L \geq 24$ m

17.1

17.1.1 See Pt C, Ch 1, Sec 10, [17].

18 Compressed air systems in ships L < 24 m

18.1

18.1.1 Starting compressed air systems

- a) The compressed air system for starting main engines is to be so arranged that it is possible to ensure the initial charge of the air receiver(s). A hand compressor may be used for this purpose. Alternatively a compressor with a hand started prime mover may be used.
- b) The prescription a) can be considered as fulfilled when the starting of the main engines is conducted, normally or under emergency, by starting devices such as fuses, inertia starters or other means deemed equivalent.
- c) When only one air compressor is used for filling the air receivers, there are to be at least two air receivers.
- d) The main engine air receivers are to have a total capacity sufficient to provide, without replenishment:
 - 12 consecutive starts of the reversible type engines
 - 6 consecutive starts of the non-reversible type engines.

18.2 Accessories for compressed air systems

18.2.1 The receivers, compressors, pipes and other accessories of the compressed air systems are to be fitted with adequate devices to avoid any appreciable overpressure in any point of the system.

18.3 Arrangement of compressed air systems

18.3.1

- a) Efficient oil and water separators are to be provided on the discharge of compressors.
- b) Non-return valves or other safety devices are to be provided on the starting air mains of each engine.

18.4 Construction - Material

18.4.1

- a) The construction and scantlings of compressed air pipes and of their accessories are to comply with the requirements of Pt C, Ch 1, Sec 10.
- b) Air receivers are to be constructed in accordance with the relevant requirements of Pt C, Ch 1, Sec 3.

19 Exhaust gas systems in ships L ≥ 24 m

19.1

19.1.1 See Pt C, Ch 1, Sec 10, [17].

20 Exhaust gas systems in ships L < 24 m

20.1 Hull outlet

20.1.1 Where exhaust gas pipes are led overboard close to the load waterline, arrangements are to be made to prevent any entry of water in the ship or in the engines while in normal operation.

20.2 Cooling and lagging

20.2.1 The exhaust gas pipes and silencers which pass through spaces of the ship where a temperature rise might be dangerous are to be efficiently cooled or lagged.

20.3 Water-cooled exhaust gas pipes

20.3.1 When water-cooled exhaust gas pipes are used, a high temperature alarm must be fitted after the water injection device. Alternatively, a low sea water flow rate may be fitted.

21 Refrigeration systems for the preservation of the catch

21.1 General

21.1.1 Refrigeration systems are to be so designed, constructed, tested and installed as to take account of the safety of the system and also the emission of chlorofluorocarbons (CFCs) or any other ozone-depleting substances from the refrigerant held in quantities or concentrations which are hazardous to human health or to the environment.

21.1.2 Methylchloride or CFCs whose ozone-depleting potential is higher than 5% of CFC-11 are not to be used as refrigerants.

21.1.3 Adequate guidance for the safe operation of the refrigeration system and emergency procedures are to be provided by means of suitable notices displayed on board the vessel.

21.2 Design of refrigeration systems

21.2.1 Refrigeration systems are to be adequately protected against vibration, shock, expansion, shrinkage, etc. and are to be provided with an automatic safety control device to prevent a dangerous rise in temperature and pressure.

21.2.2 Refrigeration systems in which toxic or flammable refrigerants are used are to be provided with drainage devices leading to a place where the refrigerant presents no danger to the vessel or to persons on board.

21.3 Arrangement of the refrigerating machinery spaces and refrigerating rooms

21.3.1 Separation of spaces

- a) Any space containing refrigerating machinery, including condensers and gas tanks utilising toxic refrigerants, is to be separated from any adjacent space by gas-tight bulkheads. Any space containing refrigerating machinery, including condensers and gas tanks utilizing toxic refrigerants, is to be fitted with a leak detection system having an indicator outside the space adjacent to the entrance and is to be provided with an independent ventilation system and a water-spraying system.
- b) For fishing vessels under 55 m in length, ammonia plants are allowed to be located in the machinery space provided that they comply with the provisions of Pt C, Ch 1, Sec 16, [2.3.2].

21.3.2 Exits from spaces

In refrigerating machinery spaces and refrigerating rooms, alarms are to be connected to the wheelhouse or control stations or escape exits to prevent persons being trapped. At least one exit from each such space is to be capable of being opened from the inside. Where practicable, exits from spaces containing refrigerating machinery using toxic or flammable gas are not to lead directly into accommodation spaces.

21.4 Breathing apparatus

21.4.1 Where any refrigerant harmful to persons is used in a refrigeration system, at least two sets of breathing apparatus are to be provided, one of which is to be placed in a position not likely to become inaccessible in the event of leakage of refrigerant. Breathing apparatus provided as part of the vessel's fire-fighting equipment may be considered as meeting all or part of this provision provided its location meets both purposes. Where self-contained breathing apparatus is used, spare cylinders are to be provided. Alternative arrangement authorized by the administration concerned may be accepted.

22 Propelling and auxiliary machinery in ships $L \geq 24$ m

22.1

22.1.1 See Pt C, Ch 1, Sec 7.

23 Propelling and auxiliary machinery in ships $L < 24$ m

23.1 Shafting

23.1.1 Propeller shaft diameter

The diameter of the shaft going through the stern tube is not to be less than the diameter d , in mm, given by the following formula:

$$d = 126 \cdot \left(\frac{P}{N} \cdot \frac{560}{R_m + 160} \right)^{1/3}$$

where:

- P : Maximum continuous power of the propulsion machinery, in kW
 N : Shaft revolutions per minute

- R_m : Minimum tensile strength of the shaft material, in N/mm². In the above formula, R_m is not to be taken greater than:
- 600 N/mm² for intermediate shaft in carbon and carbon manganese steels
 - 800 N/mm² for intermediate shaft in alloy steels
 - 600 N/mm² for propeller shaft in carbon, carbon manganese and alloy steels.

In case of stainless steels and in other particular cases, at the discretion of the Society, the value of R_m to be introduced in the above formula is to be specially considered.

Furthermore, the shaft diameter is not to be less than 25 mm for carbon steel or carbon manganese steel, and 20 mm for the other materials.

23.1.2 Intermediate shaft diameter

The diameter, in mm, of the intermediate shafts is not to be less than:

$$d' = 0,87 d$$

23.2 Shaft accessories

23.2.1 Coupling bolts

The diameter of coupling bolts at the joining faces of the couplings is to be not less than the diameter D_b , given, in mm, by the following formula, for intermediate, propeller and thrust shafts:

$$D_b = 0,65 \cdot \left(\frac{d^3 \cdot (R_m + 160)}{n \cdot D_C \cdot R_b} \right)^{1/2}$$

where:

- d' : Intermediate shaft diameter defined in [23.1.2]
 n : Number of bolts in the coupling
 D_C : Pitch circle diameter of the coupling bolts, in mm
 R_b : Ultimate tensile strength of the bolt metal, in N/mm².

23.2.2 Shaft liners

The thickness of bronze shaft liners in way of the bushes and stern gland is to be not less than the thickness e , in mm, given by the following formula:

$$e = \frac{d + 230}{32}$$

where:

- d : Actual diameter of the propeller shaft, in mm.

23.2.3 Stern bearing

a) Water lubrication

The length of the after bearing of the propeller shaft is not to be less than 4 times the rule diameter of the propeller shaft; furthermore the bearing is to be made of a type approved synthetic material.

For a bearing design substantiated by experimental data to the satisfaction of the Society, consideration may be given to a bearing length less than 4 times, but in no case less than 2 times, the rule diameter of the shaft in way of the bearing.

b) Oil lubrication

The length of the after bearing of the propeller shaft is not to be less than 2 times the rule diameter of the propeller shaft; furthermore:

- the bearing material is to be of the antifrictional type
- the oil gland is to be type approved.

c) Other arrangements

The other arrangements beside those defined in items a) and b) are to be given special consideration. The length of the after bearing of the propeller shaft is not to be less than 3,5 times the rule diameter of the propeller shaft.

23.2.4 Sealing gland

a) The sealing glands must be readily accessible, for inspection or replacement

b) The sealing glands are to be periodically inspected.

The temporary actions to be taken in case of accidental failure of a main component, as well as the inspection periodicity and the replacement schedule of parts subject to wear or deterioration, are to be specified.

The wear strength of non-metallic parts is to be established, either by satisfactory operations, or by relevant tests.

An easy to fit emergency device may be accepted.

24 Steering gear

24.1 Application

24.1.1 The provisions of this Article apply in addition to those of Pt C, Ch 1, Sec 14. with the exception of Sub-Articles Pt C, Ch 1, Sec 14, [2.1] to Pt C, Ch 1, Sec 14, [2.4].

24.2 General

24.2.1 Unless expressly provided otherwise, every ship is to be provided with main steering gear and auxiliary steering gear to the satisfaction of the Society.

24.3 Strength, performance and power operation of the steering gear

24.3.1 Main steering gear

The main steering gear and rudder stock are to be:

- a) of adequate strength and capable of steering the ship at maximum ahead service speed, which is to be demonstrated
- b) capable of putting the rudder over from 35° on one side to 35° on the other side with the ship at its deepest seagoing draught and running ahead at maximum ahead service speed and, under the same conditions, from 35° on either side to 30° on the other side in not more than 28 s
- c) operated by power where necessary to fulfil the requirements of b), and
- d) so designed that they will not be damaged at maximum astern speed; however, this design requirement need not be proved by trials at maximum astern speed and maximum rudder angle.

24.3.2 Auxiliary steering gear

The auxiliary steering gear is to be:

- a) of adequate strength and sufficient to steer the ship at navigable speed and capable of being brought speedily into action in an emergency,
- b) capable of putting the rudder over from 15° on one side to 15° on the other side in not more than 60s with the ship at its deepest seagoing draught and running ahead at one half of the maximum ahead service speed or 7 knots, whichever is the greater, and
- c) operated by power where necessary to meet the requirements of b).

24.3.3 Hand operation

Hand operation of steering gear is permitted when it requires an effort less than 160 N.

24.4 Control of the steering gear

24.4.1 Control of the main steering gear

- a) Control of the main steering gear is to be provided on the navigation bridge.
- b) Where the main steering gear is arranged in accordance with [24.5.2], two independent control systems are to be provided, both operable from the navigation bridge. This does not require duplication of the steering wheel or steering lever.

24.4.2 Control of the auxiliary steering gear

- a) Control of the auxiliary steering gear is to be provided on the navigation bridge, in the steering gear compartment or in another suitable position.
- b) If the auxiliary steering gear is power operated, its control system is also to be independent of that of the main steering gear.

24.5 Availability

24.5.1 Arrangement of main and auxiliary means for actuating the rudder

The main steering gear and the auxiliary means for actuating the rudder are to be arranged so that a single failure in one will not render the other inoperative.

24.5.2 Omission of the auxiliary steering gear

Where the main steering gear comprises two or more identical power units, auxiliary steering gear need not be fitted, provided that the main steering gear is capable of operating the rudder:

- a) as required in [24.3.1], item b), while operating with all power units
- b) as required in [24.3.2], item b), while any one of the power units is out of operation.

24.5.3 Hydraulic power supply

Hydraulic power installations supplying steering gear may also supply other equipment at the same time provided that the operation of the steering gear is not affected:

- a) by the operation of this equipment, or
- b) by any failure of this equipment or of its hydraulic supply piping.

Section 5 Electrical Installations

1 General

1.1 Application

1.1.1 The requirements contained in Part C, Chapter 2 apply to fishing vessels, except for those contained in Pt C, Ch 2, Sec 1, [2]; Pt C, Ch 2, Sec 15, [2]; Pt C, Ch 2, Sec 3, [2]; Pt C, Ch 2, Sec 3, [3]; Pt C, Ch 2, Sec 11, [1]; Pt C, Ch 2, Sec 11, [2]; Pt C, Ch 2, Sec 11, [3]; Pt C, Ch 2, Sec 11, [4], and Pt C, Ch 2, Sec 11, [5], which are replaced by all those contained in this Section.

2 Documentation to be submitted

2.1

2.1.1 The documents listed in Tab 1 are to be submitted.

Where the length is less than 24 m, the Society may give exemptions to the documents to be submitted.

Table 1 : Documents to be submitted

No.	I/A (1)	Documents to be submitted
1	A	Single line diagram of main and emergency power and lighting systems
2	I	Electrical power balance (main and emergency supply)
3	A	Calculation of short-circuit currents for each installation in which the sum of rated power of the energy sources which may be connected contemporaneously to the network is greater than 500 kW
4	A	List of circuits including, for each supply and distribution circuit, data concerning the nominal current, the cable type, length and cross-section, the nominal and setting values of the protective and control devices
5	A	Single line diagram and detailed diagram of the main switchboard
6	A	Single line diagram and detailed diagram of the emergency switchboard
7	A	Diagram of the most important section boards and motor control centres (above 100 kW)
8	A	Detailed diagram of the navigation-light switchboard
(1) A: to be submitted for approval; I: to be submitted for information.		

3 Type approved components

3.1

3.1.1 The following components are to be type approved case-by-case based on submission of adequate documentation and execution of tests:

- electrical cables
- switching devices (circuit-breakers, contactors, disconnectors, etc.) and overcurrent protective devices
- electronic components used for tasks essential to safety.

4 General requirements for system design, location and installation

4.1 Design and construction

4.1.1 The design and construction of electrical installations are to be such as to provide:

- a) the services necessary to maintain the vessel in normal operational and habitable conditions without having recourse to an emergency source of power,
- b) the services listed in [4.4.2] when failure of the main source of electrical power occurs, and
- c) protection of the crew and vessel from electrical hazards.

4.2 Distribution

4.2.1 Supply systems

Distribution systems given in Pt C, Ch 2, Sec 3, [1] may be used on board of fishing vessels. Where length is less than 24 m, on d.c. installations, two-wire systems with one pole earthed may be used.

4.2.2 General requirements given in Pt C, Ch 2, Sec 3, [1.1.3] and Pt C, Ch 2, Sec 3, [1.1.4] are applicable to fishing vessels. In addition, where length is less than 24 m, every conductor carrying the current from a circuit to the hull is to have the same cross section as the corresponding insulated conductor. In d.c. installations, one pole of generator and of supplied appliances is to be earthed in readily accessible places.

4.2.3 The hull return system of distribution is not to be used for power, heating or lighting in vessels of 75 m of length and over.

4.2.4 The requirement in [4.2.3] does not preclude, under conditions approved by the Society, the use of:

- a) impressed current cathodic protective systems
- b) limited and locally earthed systems, or
- c) insulation level monitoring devices provided the circulation current does not exceed 30 mA under the most unfavourable conditions.

4.2.5 Where the hull return system is used, all final subcircuits (all circuits fitted after the last protective device) are to be two-wire and special precautions are to be taken to the satisfaction of the Society.

4.3 Main source of electrical power

4.3.1 Where the electrical power constitutes the only means of maintaining auxiliary services essential for the propulsion and safety of the vessel, a main source of electrical power is to be provided which is to include at least two generating sets, one of which may be driven by the main engine. The Society may accept other arrangements having equivalent electrical capability.

4.3.2 The power of these sets is to be such as to ensure the functioning of the services referred to in [4.1.1] a), excluding the power required in fishing activities, processing and preservation of the catch, in the event of any one of the generating sets being stopped. However, in vessels of less than 45 m, in the event of any one of the generating sets being stopped, it is only necessary to ensure the functioning of the services essential for the propulsion and safety of the vessel.

4.3.3 The arrangement of the vessel's main source of electrical power is to be such that the services referred to in [4.1.1] a) can be maintained regardless of the number of revolutions and direction of the main propelling engines or shafting.

4.3.4 Where transformers constitute an essential part of the supply system required by this item, the system is to be so arranged as to ensure continuity of the supply.

4.3.5 The arrangement of the main electric lighting system is to be such that a fire or other casualty in spaces containing the main source of electrical power, including transformers, if any, will not render the emergency lighting system inoperative.

4.3.6 The arrangement of the emergency electric lighting system is to be such that a fire or other casualty in spaces containing the emergency source of electrical power, including transformers, if any, will not render the main lighting system inoperative.

4.3.7 Navigation lights, if solely electrical, are to be supplied through their own separate switchboard and adequate means for the monitoring of such lights are to be provided.

4.3.8 For fishing vessels propelled by electrical power and having two or more constant voltage propulsion generating sets which constitute the source of electrical energy for the ship's auxiliary services, see Pt C, Ch 2, Sec 14.

4.3.9 Load shedding or other equivalent arrangements should be provided to protect the generators required in the present Article against sustained overload.

The load shedding should be automatic.

The non-essential services, services for habitability and, if necessary, the secondary essential services may be shed in order to make sure that the connected generator set(s) is/are not overloaded.

4.3.10 Where paralleling operation of the generators is needed, necessary instruments for this operation are to be provided.

4.3.11 Where the length is greater than 24 m, the measurement devices are to be in accordance with the general requirements given in Pt C, Ch 2, Sec 8, [1.6.1] to Pt C, Ch 2, Sec 8, [1.6.8].

Where the length is less than 24 m.

- a) The following instruments are to be normally provided:
- for each generator:
 - one ammeter with mark indicating the normal full load value (for installations where the rated voltage is below 24 V and fitted with a load limit, only a charge control lamp can be provided)
 - one voltmeter
 - one lamp indicator to indicate the generator voltage
 - one battery charging control lamp
 - for each battery:
 - one ammeter with two-sided deviation
 - for busbars:
 - one voltmeter
 - for three-phase system, it is to be provided, in addition:
 - one ammeter per phase or one ammeter with commutator permitting to measure the current in each phase
 - one frequency meter
 - one synchronising device if alternators are arranged to run in parallel
 - one wattmeter for alternators over 50 kVA.

b) Protection:

Measuring instruments connected to the network and indicator lamps are to be protected by a fuse. Where a measuring instrument and an indicator lamp correspond to the same indication, each one is to be provided with a fuse.

Requirements given in Pt C, Ch 2, Sec 8, [1.6.13], Pt C, Ch 2, Sec 8, [1.6.14] and Pt C, Ch 2, Sec 8, [1.6.15], are applicable to all fishing vessels.

4.3.12 The main switchboards are to be placed far away from flammable gas, vapour accumulation, acid gas or other liquid. Their location is to be such that there is no pipe carrying liquids above, beside or near them. When this cannot be avoided, pipes are to be built joint less or provided with protections.

4.4 Emergency source of electrical power

4.4.1 A self-contained emergency source of electrical power located, to the satisfaction of the Society, outside machinery spaces is to be provided and so arranged as to ensure its functioning in the event of fire or other causes of failure of the main electrical installations.

4.4.2 The emergency source of electrical power is to be capable, having regard to starting currents and the transitory nature of certain loads, of serving simultaneously for a period of at least three hours:

- a) the VHF radio installation and, if applicable:
- 1) the MF radio installation
 - 2) the ship earth station and
 - 3) the MF/HF radio installation
- b) internal communication equipment, fire detection systems and signals which may be required in an emergency
- c) the navigation lights if solely electrical and the emergency lights:
- 1) of launching stations and overside of the vessel
 - 2) in all alleyways, stairways and exits
 - 3) in spaces containing machinery or the emergency source of power
 - 4) in control stations, and
 - 5) in fishing handling and fish processing spaces, and
- d) the operation of the emergency fire pump, if any.

4.4.3 The emergency source of electrical power may be either a generator or an accumulator battery.

4.4.4 Where the emergency source of electrical power is a generator, it is to be provided both with an independent fuel supply and with efficient starting arrangements to the satisfaction of the Society. Unless a second independent means of starting the emergency generator is provided, the single source of stored energy is to be protected to preclude its complete depletion by the automatic starting system.

4.4.5 Where the emergency source of electrical power is an accumulator battery, it is to be capable of carrying the emergency load without recharging whilst maintaining the voltage of the battery throughout the discharge period within plus or minus 12% of its nominal voltage. In the event of failure of the main power supply, this accumulator battery is to be automatically connected

to the emergency switchboard and is to immediately supply at least those services specified in [4.4.2], items b) and c). The emergency switchboard is to be provided with an auxiliary switch allowing the battery to be connected manually, in case of failure of the automatic connection system.

4.4.6 When the length is less than 24 m, the start of the main engine of the ship is carried out by electrical starter and where the emergency source of power is a storage battery, the emergency source of power can be considered as the second required starting power source for the main engine. Then:

- The starting system cables are to be designed to permit the necessary commutation with a change over switch and fixed connections.
- The available power of the emergency battery is to be adequate to supply the emergency services during the time specified in above paragraphs, and, in principle, have the capacity of six consecutive starts of the main engine.

4.4.7 The emergency switchboard is to be installed as near as is practicable to the emergency source of power and is to be located in accordance with [4.4.1]. Where the emergency source of power is a generator, the emergency switchboard is to be located in the same place unless the operation of the emergency switchboard would thereby be impaired.

4.4.8 An accumulator battery, other than batteries fitted for the radio transmitter and receiver in vessels of less than 45 m in length, is to be installed in a well ventilated space which is not to be the space containing the emergency switchboard. An indicator is to be mounted in a suitable place on the main switchboard or in the machinery control room to indicate when the battery constituting the emergency source of power is being discharged.

4.4.9 The emergency switchboard is to be supplied in normal operation from the main switchboard by an interconnector feeder which is to be protected at the main switchboard against overload and short-circuit and which is to be disconnected automatically at the emergency switchboard upon failure of the main source of electrical power.

Where the system is arranged for feedback operation, the interconnector feeder is also to be protected at the emergency switchboard at least against short-circuit.

For ships whose length is equal to or greater than 45 m, the arrangement at the emergency switchboard is to be such that in the event of failure of the main power supply an automatic connection of the emergency supply will be provided.

4.4.10 The emergency generator and its prime mover and any emergency accumulator battery are to be so arranged as to ensure that they will function at full rated power when the vessel is upright and when rolling up to an angle of 22,5° either way and simultaneously pitching 10° by bow or stern, or in any combination of angles within those limits.

4.4.11 The emergency source of electrical power and automation starting equipment is to be so constructed and arranged as to enable adequate testing to be carried out by the crew while the vessel is in operating condition.

4.4.12 When the length is less than 24 m, the Society may exempt Owners from the installation of the emergency source of electrical power.

4.4.13 Where emergency generator is used in port, the requirements stated in Pt C, Ch 2, Sec 3, [2.4] are applicable.

4.5 Precaution against shock, fire and other hazards of electrical origin

4.5.1 Exposed permanently fixed metal parts of electrical machines or equipment which are not intended to be live but which are liable under fault conditions to become live are to be earthed (grounded) unless:

- a) they are supplied at a voltage not exceeding 50 V direct current or 50 V, root mean square between conductors; auto-transformers are not to be used for the purpose of achieving this alternative current voltage, or
- b) they are supplied at a voltage not exceeding 250 V by safety isolating transformers supplying one consuming device only, or
- c) they are constructed in accordance with the principle of double insulation.

4.5.2 Electrical apparatus is to be so constructed and installed that it will not cause injury when handled or touched in the normal manner.

4.5.3 Main and emergency switchboards are to be so arranged as to afford easy access as may be needed to apparatus and equipment, without danger to attendants. The sides, backs and, where necessary, the fronts of switchboards are to be suitably guarded. Exposed live parts having voltages to earth exceeding a voltage to be specified by the Society are not to be installed on the front of the switchboards. There are to be non-conducting mats or gratings at the front and rear, where necessary.

4.5.4 When a distribution system, whether primary or secondary, for power, heating or lighting, with no connection to earth is used, a device capable of monitoring the insulation level to earth is to be provided.

4.5.5 When a distribution system is in accordance with [4.5.4] and a voltage exceeding 50 V direct current or 50 V, root mean square, between conductors, is used, a device capable of continuously monitoring the insulation level to earth and of giving an audible or visual indication of abnormally low insulation values is to be provided.

4.5.6 Distribution systems which are supplied at a voltage not exceeding 250 V direct current or 250 V, root mean square, between conductors, and which are limited in extent, may comply with [4.5.4], subject to the satisfaction of the Society.

4.5.7 Except as permitted by the Society in exceptional circumstances, all metal sheaths and armour of cables are to be electrically continuous and to be earthed.

4.5.8 All electrical cables are to be at least of a flame-retardant type and are to be so installed as not to impair their original flame-retarding properties. The Society may permit the use of special types of cables where necessary for specific applications, such as radio frequency cables, which do not comply with the foregoing.

4.5.9 Cables and wiring serving essential or emergency power, lighting, internal communications or signals are as far as practicable to be routed clear of galleys, machinery spaces of category A and other high fire risk areas and laundries, fish handling and fish processing spaces and other spaces where there is a high moisture content. Cables connecting fire pumps to the emergency switchboard are to be of a fire-resistant type where they pass through high fire risk areas. Where practicable, all such cables are to be run in such a manner as to preclude their being rendered unserviceable by heating of the bulkheads which may be caused by a fire in an adjacent space.

4.5.10 Where cables which are installed in spaces where the risk of fire or explosion exists in the event of an electrical fault, special precautions against such risk are to be taken to the satisfaction of the Society. When fitted in places where flammable gases or vapours may accumulate, or in rooms intended to mainly contain accumulators, paint or similar material, the equipment is to be of a safety type approved by the Society.

4.5.11 Wiring is to be supported in such a manner as to avoid chafing or other damage.

4.5.12 Terminations and joints in all conductors are to be made such that they retain the original electrical, mechanical, flame-retarding and, where necessary, fire-resisting properties of the cable.

4.5.13 Cables installed in refrigerated compartments are to be suitable for low temperatures and high humidity.

4.5.14 Circuits are to be protected against short-circuit. Circuits are also to be protected against overload, unless otherwise specified in these Rules or where the Society may exceptionally otherwise permit.

4.5.15 The rating or appropriate setting of the overload protective device for each circuit is to be permanently indicated at the location of the protective device.

4.5.16 Lighting fittings are to be so arranged as to prevent temperature rises which could damage the wiring and to prevent surrounding material from becoming excessively hot.

4.5.17 Lighting or power circuits terminating in a space where the risk of fire or explosion exists are to be provided with isolating switches outside the space.

4.5.18 The housing of accumulator batteries is to be constructed and ventilated to the satisfaction of the Society.

4.5.19 Electrical or other equipment which may constitute a source of ignition of flammable vapours is not permitted in these compartments except as provided for in [4.5.21].

4.5.20 An accumulator battery is not to be located in accommodation spaces unless installed in a hermetically sealed container.

4.5.21 In spaces where flammable mixtures are liable to collect and in any compartments assigned principally to the containment of an accumulator battery, no electrical equipment is to be installed unless the Society is satisfied that it is:

- a) essential for operational purposes
- b) of a type which will not ignite the mixture concerned
- c) appropriate for the space concerned, and
- d) appropriately certified for safe usage in the dusts, vapours or gases likely to be encountered.

4.5.22 Where shore supply is provided, requirements stated in Pt C, Ch 2, Sec 3, [3.7] are applicable. The socket-outlets used for the supply of the ship from the shore network and when the voltage exceeds 50 V, are to be provided with a built-in earth connection provided to be connected to the earth.

4.5.23 On board of ship with non-metallic hull, bonding is to be provided between the frame of generators, the bed plate of the pumps, the bed plate of the motors and the earth plate, if fitted. All the elements of the fuel installation are to be electrically bonded and connected to the above bonding.

4.5.24 If the protection of cables against overload current is made by fuses, their rating is to be selected according to the maximum permissible current in the cable.

4.5.25 Particular attention is to be paid to the fixing of equipment made of cast brass or other copper alloys on aluminium decks or bulkheads.

4.5.26 Heaters

Electric heaters are to be permanently installed.

They are to be constructed and installed in such a way that clothing or other combustible objects cannot be left there or be hung above these heaters.

4.6 Engineers' alarm

4.6.1 In vessels of 75 m in length and over, an engineers' alarm is to be provided to be operated from the engine control room or at the manoeuvring platform as appropriate, and is to be clearly audible in the engineers' accommodation.

4.7 Steering gear

4.7.1 For the steering gear, general requirements included in Ch 15, Sec 4, [24] are applicable. Where length of the fishing vessel is less than 24 m, the Society may give exemptions to these requirements.

4.8 Fire detection and fire alarm

4.8.1 The fire detection and fire alarm system are to be supplied from the main source and an emergency source.

4.9 Alarm - Communication

4.9.1 For the crew muster, an alarm system operated from the bridge is to be provided. This system may be part of the general alarm system.

4.9.2 Ships of 12 m or more in length are to be equipped with a system enabling the general broadcast of alarm and messages in case of damage or ship escape.

4.9.3 The bridge operating compartment is to be fitted with the internal communication and control means as quoted hereunder:

- An engine room telegraph with repeater, or equivalent system, is to be provided and duplicated by another independent system, enabling the communication with the engine control position. If the size and arrangement of the ship make useless the equipment mentioned above, only a dual calling system such as telephone, megaphone or bell may be fitted.
- If the propelling machinery is remote-controlled from the bridge-operating compartment, at least one order telegraph, reversible or with repeater, is to be fitted at the local direct engine control position.
- Furthermore, unless the size and arrangement of the ship make useless this equipment, the bridge operating compartment is to be connected by means of a reversible voice communication system to the local control of steering gear, propelling machinery and the service accommodation.

4.10 Final sub-circuits

4.10.1 Every final sub-circuit connected to a distribution panel is to be protected, unless otherwise specified, by a fuse or a maximum current circuit breaker on each insulated pole. These circuits can be controlled by single pole switches in dry spaces of the accommodation.

A separate final sub-circuit is to be provided for every apparatus assuming an essential service and for each motor rated 1 kW or more.

4.11 Electric cables

4.11.1 General requirements given in Pt C, Ch 2, Sec 3, [9] are applicable for all fishing vessels.

4.11.2 Choice of runs

- a) Cable runs are to be as straight and accessible as possible.
- b) Cable runs are to be fitted away from source of water. Cables exposed to the risk of mechanical damage, if not armoured or enclosed in steel conduits, are to be protected by a casing.
- c) The cable runs are to be so designed that the internal radius of bend does not exceed at any point the permissible value for the cable concerned. In the absence of values specified by the manufacturer, the following values are to be adopted as minima for the internal radius of bend:
 - 4 d for rubber-like insulated cables without metallic covering (6 d if $d > 25$ mm)
 - 6 d for rubber-like insulated cables with metallic covering or for silicone asbestos cables.

4.11.3 Cable fixing

- a) Cables are to be bunched as regularly as possible.
- b) Cables are to be so arranged as to avoid any friction; if needed, fastening parts are to be used. The distance between fastening parts is to be defined according to the cable nature and the special installation provisions. The distance between two fastening parts is generally not to exceed 0,50 m.

4.12 Switchboard

4.12.1 Installation

When the voltage exceeds 50 volts, AC or DC, an insulated mat, grating or impregnated wood surface is to be provided in front of switchboards and also at the rear if access to the rear is provided. The insulated mat, grating or surface is to be oil-resistant and non-slippery.

4.12.2 Design - Construction

Generally, switchboards or enclosures containing switchboards are to be constructed of durable, flame retardant and non-hygroscopic materials. In addition, mechanical features of the materials are to be suitable for the service conditions.

Live parts normally submitted to a voltage exceeding 50 volts are not to be installed without protection on the front of switchboards.

The switchboard frame or enclosures containing switchboards are to be earthed.

Air clearances between live parts are to be suitable for the rated voltage or protected by means of insulating and fireproof shields.

Every switchboard part, including the connections, is to be easily accessible.

4.13 Rotating electrical machines

4.13.1 Location - Installation

Machines and their gears are to be located in spaces suitably ventilated where flammable dusts, vapours or gases cannot accumulate. Where this condition, in the case of motors, cannot be fulfilled, the Society is to be advised accordingly and a special consideration will be given, after examination, of the proposed arrangements.

4.13.2 Earthing

Bed plates and framework of machines or generating sets are to be efficiently earthed; no insulating material is to be placed between the prime movers and the alternators and generally between the prime movers and the driven machines, unless there is one efficient earthing of each part.

4.13.3 Generators speed control

Prime movers for driving generators are to be fitted with a speed regulator in such a way that at all loads between no load and rated power the permanent speed variations cannot exceed 5% of the rated speed. For Diesel generating sets, when the rated power is suddenly thrown off, the transient speed variations are not to exceed 10%.

The generators driven by the propulsion engine, by a geared shaft or by an auxiliary set intended for another purpose, are to be designed with consideration that the variation of speed may occur in service.

4.13.4 Particular provisions for the motor control device - Starters

- a) DC and AC motors of more than 0,5 kW are to be fitted with a under-voltage protection and a protection against overload. Under-voltage protection may not be provided for steering gear motor or any other motor the continuous running of, which is essential.
- b) When the starter, the selector switch or all other equipment used to cut off completely the supply of the motor is at a distance from it, it is recommended that one of the following measures be applied:
 - locking of the disconnecting switch of the circuit in open position, or removable fuses
 - installation near to the motor of a second disconnecting switch.

4.14 Batteries

4.14.1 As general, Pt C, Ch 2, Sec 11, [6] is applicable.

4.14.2 Where the length is less than 24 m, the following is also applicable:

- Batteries which can be charged by a power exceeding 2 kW (calculated from the maximum charging current of the charging apparatus and from the nominal voltage of the battery) are to be installed in a ventilated suitable space or in a locker protected from dangerous gas accumulation.

4.14.3 For all fishing vessels:

- a) All spaces especially reserved for batteries, including lockers or chests, boxes, shelves are to be protected against the deleterious effects of the electrolyte. The batteries are to be so manufactured and installed that no electrolyte discharge may occur under 22°5 inclination.
- b) Deck boxes are to be provided with exhaust ducts on top and air inlets at lower part. The assembly is to be suitably weatherproof. For battery of low capacity, only openings on the top of the battery box are required.

5 Lightning protection

5.1 Application

5.1.1 A lightning protection system is to be fitted for:

- a) ships with wooden hull or of composite construction with wooden masts
- b) ships with wooden hull or of composite construction with steel masts
- c) ships with steel hull with wooden masts.

5.1.2 Lightning conductors are to be fitted to all wooden masts or topmasts. In vessels constructed of non-conductive materials, the lightning conductors are to be connected to a copper plate fixed to the vessel's hull well below the waterline.

5.1.3 Lightning fittings exposed to risks of mechanical damage are to be suitably protected or strongly built.

Section 6 Fire Protection

1 General

1.1 Application

1.1.1 This Section provides requirements for the fire safety of ships having the service notation **fishing vessel** and a length of 65 m or less.

Type approval of materials and products listed in a) to h) of [1.3.1] and Articles [5], [6], [7], [8], [9] and [10] of this Section apply only to ships assigned with the additional service feature **F**.

The fire safety of fishing vessels having a length of more than 65 m is to comply with the provisions of Part C, Chapter 4.

1.2 National regulations

1.2.1 When the Administration of the State whose flag the ship is entitled to fly has issued specific regulations covering fire protection, the Society may accept such regulations for classification purpose in lieu of those given in this Chapter.

In such cases, a memorandum indicating those specific regulations applied is issued.

1.3 Type approved products

1.3.1 The following materials, equipment, systems or products in general used for fire protection are to be type approved by the Society, except for special cases for which the acceptance may be given for individual ships on the basis of suitable documentation and/or tests:

- a) fire-resisting and fire-retarding divisions (bulkheads or decks) and associated doors
- b) automatic closing devices of fire doors
- c) materials for pipes penetrating A or B class divisions (where they are not of steel or other equivalent material)
- d) materials for oil or fuel oil pipes (where they are not of steel or copper and its alloys)
- e) bulkhead or deck penetrations for electrical cables passing through A or B class divisions
- f) materials with low flame spread characteristics including paints, varnishes and similar, when they are required to have such characteristics
- g) non-combustible materials
- h) non-readily igniting materials for primary deck coverings
- i) fixed foam fire-extinguishing systems and portable foam fire-extinguishing units
- j) sensing heads for automatic fire alarm and fire detection systems
- k) portable fire extinguishers
- l) extinguishing media substitute for the foam in fire extinguishers
- m) fire hoses
- n) fire hydrants and nozzles, including dual-purpose nozzles, for fire hoses.

As regards the type approval, the requirements of Part A apply.

1.4 Definitions

1.4.1 Foreword

For the purpose of this Section, unless otherwise stated, the definitions given in [1.4.2] to [1.4.13] below apply.

1.4.2 Non-combustible material

Non-combustible material is a material which neither burns nor gives off flammable vapours in sufficient quantity for self-ignition when heated to approximately 750°C. Such property is to be demonstrated by means of a test performed in accordance with a procedure accepted by the Society.

Any other material is to be considered as a combustible material.

1.4.3 Standard fire test - A class divisions - B class divisions

Refer to the definitions given in Pt C, Ch 4, Sec 1, [3.1.1] and Pt C, Ch 4, Sec 1, [3.4.1].

The Society may require a test of a prototype bulkhead of A or B class to ensure that it meets the requirements for integrity or temperature rise.

1.4.4 Steel or other equivalent material

Where the words “steel or other equivalent material” occur, “equivalent material” means any non-combustible material which, by itself or due to insulation provided, has structural and integrity properties equivalent to steel at the end of the applicable exposure to the standard fire test (e.g. aluminium alloy with appropriate insulation).

1.4.5 Low flame spread

“Low flame spread” means that the surface thus described offers an adequate resistance to the spread of flame. Such a property is to be demonstrated by a test procedure deemed acceptable by the Society.

1.4.6 Accommodation spaces

“Accommodation spaces” are those spaces normally used by the crew such as corridors, lavatories, cabins, offices, lounges, dining rooms and other similar spaces.

1.4.7 Service spaces

“Service spaces” are those spaces used for galleys, pantries containing cooking appliances, lockers, storerooms, workshops other than those forming part of machinery spaces, and similar spaces and trunks to such spaces. They also include the spaces used for the storage of the fishing nets.

1.4.8 Cargo spaces

“Cargo spaces” are all spaces used for the storage of the fish and the trunks to such spaces.

1.4.9 Machinery spaces of category A

“Machinery spaces of category A” are those spaces which contain internal combustion type machinery, used for:

- either main propulsion, or
- other purposes where such machinery has in the aggregate a total power output of not less than 750 kW,

or which contain any oil-fired boiler or fuel unit.

1.4.10 Machinery spaces

“Machinery spaces” are those machinery spaces of category A and all other spaces containing the propulsion machinery, boilers, fuel oil units, steam and internal combustion engines, generators and major electric motors, steering gear, oil filling stations, ventilation and air conditioning machinery, refrigerating machinery, stabilisers and similar spaces or trunks to such spaces.

1.4.11 Control stations

“Control stations” are those spaces containing the main navigating equipment, the ship’s radio, the emergency source of power, or where the fire recording and fire control equipment is centralised.

1.4.12 Continuous B-class ceilings or linings

“Continuous B-class ceilings or linings” are those B-class ceilings or linings which terminate only at a “A” or “B” class division.

1.4.13 Materials which do not readily ignite

“Materials which do not readily ignite” are materials having approved characteristics of ignitability. These characteristics are to be obtained from a test procedure deemed acceptable by the Society.

2 Water fire-fighting system

2.1 General

2.1.1

- a) Every ship is to be provided with a water fire-fighting system consisting of fire pumps, fire main, hydrants and hoses complying as applicable with the provisions of this Article, depending on the length of the ship.
- b) The water fire-fighting system is to be independent of any other system of the ship. A connection with the washing system is permitted, however.

2.2 Number and type of fire pumps

2.2.1 Ships with $L \geq 45$ m

All ships having a length of 45 m or more are to be provided with:

- at least two main fire pumps; one is to be independently driven and power operated and the other may be driven by the propulsion engine
- one emergency fire pump complying with [2.3.2], if a fire in any compartment could put all the fire pumps out of action.

Note 1: In the case of ships having a restricted navigation notation, the emergency fire pump may be omitted.

2.2.2 Ships with 24 m ≤ L < 45 m

Ships having a length of 24 m and above but less than 45 m are to be provided with:

- at least one main fire pump, independently driven and power-operated
- one emergency fire pump, except when the main fire pump, its source of power and its sea connection are located outside the spaces containing the propulsion machinery or oil fired boilers.

Note 1: In the case of ships having a restricted navigation notation, the emergency fire pump may be omitted.

2.2.3 Ships with 15 m ≤ L < 24 m

Ships having a length of 15 m and above but less than 24 m are to be provided with:

- at least one pump for the fire fighting service, power-operated
- one hand pump complying with [2.3.3], except when the power-operated pump is independently driven.

2.2.4 Ships with L < 15 m

Ships having a length less than 15 m are to be provided with at least one hand pump complying with [2.3.3].

2.3 Characteristics and arrangement of fire pumps

2.3.1 Main fire pumps

a) When delivering together for fire-fighting purposes at the pressure specified in [2.4.1], item b), the required fire pumps, other than hand pumps and the emergency fire pump, are to have a total capacity Q, in m³/h, not less than that determined from the following formula:

$$Q = (0,15\sqrt{L(B+D)} + 2,25)^2$$

where:

- L : Length of the ship between perpendiculars, in m
- B : Breadth of the ship, in m
- D : Depth of the ship, measured up to the bulkhead deck, in m.

However, the total capacity of the main fire pumps need not exceed 180 m³/h.

- b) When several power-operated fire pumps other than the fire emergency pump are required, each pump is to have a capacity not less than 80% of the total required capacity divided by the minimum number of required fire pumps. Each such pump is, in any event, to be capable of delivering at least the two jets of water required in [2.4.1], item b). These fire pumps are to be capable of supplying the fire main system under the required conditions. Where more than the minimum number of required pumps are installed, the capacity of such additional pumps may be less than that required above, provided it is deemed satisfactory by the Society.
- c) Sanitary, ballast, bilge or general service pumps may be accepted as fire pumps, provided they are not normally used for pumping oil and that, if they are subject to occasional duty for the transfer or pumping of fuel oil, suitable change-over arrangements are fitted.

2.3.2 Emergency fire pumps

The emergency fire pump and its location are to comply with the following requirements:

- a) The capacity of the pump is not to be less than 40% of the total capacity of the main fire pumps and in any case not less than:
- 25 m³/h for ships having a length of 45 m or more
 - 15 m³/h for ships having a length less than 45 m.
- b) When the pump is delivering the quantity of water required by clause a) above, the pressure at any hydrant is not to be less than the minimum pressures required in [2.4.1], item b).
- c) Any diesel driven power source for the emergency fire pump is to be capable of being readily started in all the temperature conditions likely to be encountered, taking into account the navigation assigned to the ship.
- d) Any service fuel tank is to contain a sufficient quantity of fuel to enable the emergency fire pump to run on full load for at least 3 h and sufficient reserves of fuel are to be available outside machinery spaces to enable the pump to run on full load for an additional 15 h.
- e) The emergency fire pump is to be of the self-priming type and capable of operating under all conditions of immersion, list, trim, roll and pitch likely to be encountered in service. The sea suction valve is to be capable of being operated from a position close to the pump.
- f) The emergency fire pump and its source of power are to be installed in a safe and readily accessible position located in a separate compartment as far as possible from the compartment containing the main fire pumps and their source of power.

When this is not practicable, the emergency fire pump may be located in a compartment adjacent to the one containing the main fire pumps, provided that the bulkheads and decks forming the boundaries of both compartments are insulated to A-60 standard.

Note 1: For ships having a length less than 45 m and a restricted navigation notation, the emergency fire pump may also be portable and located in a space other than the one containing the main fire pump.

2.3.3 Hand pumps

Hand pumps are to have a capacity of at least two thirds of that required for the bilge pump and a total suction head to project a sufficient jet of water to the satisfaction of the Society.

2.4 Fire main, hydrants and hoses

2.4.1 Diameter of, and pressure in, the fire main

- a) The diameter of the fire main and water service pipes is to be sufficient for the effective distribution of the maximum required discharge from all the main fire pumps operating simultaneously. However, this diameter need only be sufficient for the discharge of 140 m³/h.
- b) When main power fire pumps are delivering the quantity of water required in [2.3.1] item a) through the fire main, fire hoses and nozzles, the pressure maintained at any hydrant is not to be less than 0,25 N/mm².

2.4.2 Pipes and hydrants

- a) Materials readily rendered ineffective by heat are not to be used for the fire main and hydrants unless adequately protected. The pipes and hydrants are to be so placed that the fire hoses may be easily coupled to them. The arrangement of pipes and hydrants is to be such as to avoid the possibility of freezing.
- b) A valve is to be fitted to serve each fire hose so that any hose may be removed while the fire pumps are at work.
- c) Isolating valves to separate the section of the fire main within the machinery space containing the main fire pump or pumps from the rest of the fire main are to be fitted in easily accessible and safe positions outside the machinery space. The fire main is to be so arranged that, when the isolating valves are shut, all the hydrants of the ship except those in the machinery space referred to above may be supplied with water by a fire pump not located in this machinery space through pipes which do not enter this space. Exceptionally, the Society may permit short lengths of the emergency fire pump suction and discharge piping to penetrate the machinery space if it is impracticable to route it externally provided that the integrity of the fire main is maintained by the enclosure of the piping in a substantial steel casing.

2.4.3 Number and position of hydrants

- a) Fire hydrants are to be positioned so as to allow easy and quick connection of fire hoses and so that at least one jet can be directed into any part of the ship which is normally accessible during navigation.
- b) The jet required in item a) is to be from a single length of fire hose.
- c) In addition to the requirements of item a), machinery spaces of category A are to be provided with at least one fire hydrant complete with fire hose and dual-purpose nozzle. This fire hydrant is to be located outside the space and near the entrance.
- d) For every required fire hydrant there is to be one fire hose. At least one spare fire hose is to be provided in addition to this requirement.
- e) Single lengths of fire hose are not to exceed 20 m.
- f) Fire hoses are to be of an approved material. Each fire hose is to be provided with couplings and a dual-purpose nozzle.
- g) Except where fire hoses are permanently attached to the fire main, the couplings of fire hoses and nozzles are to be completely interchangeable.
- h) The nozzles as required by item f) are to be appropriate to the delivery capacity of the fire pumps fitted, but in any case are to have a diameter of not less than 12 mm.

3 Fire-extinguishing appliances in machinery spaces

3.1 Fixed fire-extinguishing systems

3.1.1 Spaces containing oil-fired boilers, fuel oil units or internal combustion machinery having a total power output of not less than 750 kW are to be provided with one of the following fixed fire-extinguishing systems, to the satisfaction of the Society:

- a pressure water-spraying installation
- a fire-smothering gas installation
- a fire-extinguishing installation using vapours from low toxicity vapourizing liquids, or
- a fire-extinguishing installation using high expansion foam.

3.1.2 Fire-extinguishing systems using halogenated hydrocarbon are prohibited.

3.1.3 Where the engine and boiler rooms are not entirely separated from each other or if fuel oil can drain from the boiler room into the engine room, the combined engine and boiler rooms are to be considered as one compartment.

3.1.4 Installations listed in [3.1.1] are to be controlled from readily accessible positions outside the protected spaces not likely to be cut off by a fire in the protected space. Arrangements are to be made to ensure the supply of power and water necessary for the operation of the system in the event of fire in the protected space.

3.2 Additional fire-extinguishing arrangements

3.2.1 In all machinery spaces of category A at least two portable extinguishers are to be provided, of a type suitable for extinguishing fires involving fuel oil. Where such spaces contain machinery, which has a total power output of not less than 250 kW, at least three such extinguishers are to be provided. One of the extinguishers is to be stowed near the entrance to the space.

3.2.2 Ships having machinery spaces not protected by a fixed fire-extinguishing system are to be provided with at least a 45 l foam extinguisher or its equivalent, suitable for fighting oil fires. Where the size of the machinery spaces makes this provision impracticable, the Society may accept an additional number of portable fire extinguishers.

4 Fire extinguishers

4.1 Design and installation of fire extinguishers

4.1.1 General

All fire extinguishers are to be of a type and characteristics approved by the Society.

4.1.2 Equivalences

- a) The Society reserves the right to establish equivalences between the various types of extinguishers.
- b) Foam extinguishers may be replaced by equivalent extinguishers deemed appropriate by the Society.

4.1.3 Spare charges

A sufficient number of spare charges is to be provided. In general, spare charges are to be provided for 10% of the portable water or foam extinguishers on the ship, with a minimum of 5 spare charges of each type. However, the number of spare charges need not exceed the number of water or foam extinguishers on board.

4.1.4 Capacity of portable fire extinguishers

The capacity of required portable fluid extinguishers is not to be more than 13,5 l and not less than 9 l. Other extinguishers are to be at least as portable as the 13,5 l fluid extinguishers and are to have a fire-extinguishing capability at least equivalent to a 9 l fluid extinguisher.

4.1.5 Extinguishing medium

Fire extinguishers containing an extinguishing medium which, in the opinion of the Society, either by itself or under expected conditions of use gives off toxic gases in such quantities as to endanger persons are not permitted.

4.1.6 Installation

One of the portable fire extinguishers intended for use in any space is to be stowed near the entrance to that space.

4.2 Arrangement of fire extinguishers in accommodation and service spaces

4.2.1 General

All ships are to be provided with a sufficient number of portable fire extinguishers such that, in any accommodation or service spaces, a fire extinguisher is readily available in case of need. The type of the extinguisher is to be suitable for the type of fire which is likely to break out in the space concerned.

4.2.2 Number and type of extinguishers in the various spaces

- a) Accommodation spaces are to be provided with at least:
 - 5 water or foam extinguishers, with a minimum of one such extinguisher for each 'tweendeck, for ships having a length of 45 m or more
 - 3 water or foam extinguishers, with a minimum of one such extinguisher for each 'tweendeck, for ships having a length of 24 m or more but less than 45 m
 - 1 water or foam extinguisher for each 'tweendeck, for ships having a length less than 24 m.
- b) In the vicinity of switchboards or section boards having a power of 20 kW or more, at least one carbon dioxide or powder extinguisher is to be provided.
- c) Spaces containing a galley are to be provided with at least one foam or powder extinguisher.

- d) Stores containing paint or other easily flammable products used on board are to be provided with at least one foam or carbon dioxide or powder extinguisher.
- e) The navigation bridge is to be provided with at least one foam or carbon dioxide extinguisher.
- f) The spaces containing the ship's radio equipment are to be provided with at least two carbon dioxide extinguishers.

Note 1: In small ships where the sole electric switchboard and/or the sole radio station is/are located on the navigation bridge or in the same position as the wheelhouse, only two extinguishers need be provided, one of the water type, the other of the carbon dioxide type or equivalent.

5 Structural fire protection

5.1

5.1.1 Hull, superstructures, structural bulkheads, decks and deckhouses are to be of steel. However, in special cases, the Society may accept the use of other equivalent materials (such as aluminium alloys) when the fire risk has been taken into account and provided that such material is so insulated that, in the event of fire, the structure cannot collapse.

5.2 Ships of 45 m in length and over

5.2.1 The decks and bulkheads separating machinery spaces of category A from accommodation spaces, service spaces or control stations are to be constructed to "A-60" Class standard where the machinery space of category A is not provided with a fixed fire-extinguishing system and to "A-30" Class standard where such a system is fitted. Decks and bulkheads separating other machinery spaces from accommodation, service spaces and control stations are to be constructed to "A-0" Class standard. Decks and bulkheads separating control stations from accommodation and service spaces are to be constructed to "A" Class standard, insulated to the satisfaction of the Society, except that the Society may permit the fitting of "B-15" Class divisions for separating such spaces as skipper's cabin from the wheelhouse.

5.2.2

- a) The bulkheads of corridors serving accommodation spaces, service spaces and control stations are to be of "B-15" Class divisions.
- b) Any bulkhead required by item a) is to extend from deck to deck unless a continuous ceiling of the same Class as the bulkhead is fitted on both sides of the bulkhead, in which case the bulkhead can terminate at the continuous ceiling.

5.2.3 Interior stairways serving accommodation spaces, service spaces or control stations are to be of steel or other equivalent material. Such stairways are to be within enclosures constructed of "B-15" Class divisions, provided that where a stairway penetrates only one deck, it need be enclosed at one level only.

5.2.4 Doors and other closures of openings in bulkheads and decks referred to in [5.2.1] and [5.2.2], doors fitted to stairway enclosures referred to in [5.2.3] and doors fitted in engine and boiler casings, are to be as far as practicable equivalent in resisting fire to the divisions in which they are fitted. Doors to machinery spaces of category A are to be self-closing.

5.2.5 Lift trunks, which pass through the accommodation and service spaces, are to be constructed of steel or equivalent material and are to be provided with means of closing which will permit control of draught and smoke.

5.2.6

- a) The boundary bulkheads and decks of spaces containing any emergency source of power and bulkheads and decks between galleys, paint rooms, lamp rooms or any store-rooms which contain appreciable quantities of highly flammable materials, and accommodation spaces, service spaces or control stations are to be of "A" Class divisions insulated to the satisfaction of the Society, having in mind the risk of fire, except that the Society may accept "B-15" Class divisions between galley and accommodation spaces, service spaces and control stations when the galley contains electrically heated furnaces, electrically heated hot water appliances or other electrically heated appliances only.
- b) Highly flammable products are to be carried in suitably sealed containers.

5.2.7 Where bulkheads or decks, required by [5.2.1], [5.2.2], [5.2.4] or [5.2.6] to be of "A" Class or "B" Class divisions, are penetrated for the passage of electrical cables, pipes, trunks, ducts, etc., arrangements are to be made to ensure that the fire integrity of the division is not impaired.

5.2.8 Air spaces enclosed behind ceilings, panellings or linings in accommodation spaces, service spaces and control stations are to be divided by close-fitting draught stops spaced not more than 7 m apart.

5.2.9 Windows and skylights to machinery spaces are to be as follows:

- a) Where skylights can be opened they are to be capable of being closed from outside the space. Skylights containing glass panels are to be fitted with external shutters of steel or other equivalent material permanently attached.
- b) Glass or similar materials are not to be fitted in machinery space boundaries. This does not preclude the use of wire-reinforced glass for skylights and glass in control rooms within the machinery spaces; and
- c) In skylights referred to in item a) wire-reinforced glass is to be used.

5.2.10 Insulating materials in accommodation spaces, service spaces except domestic refrigerating compartments, control stations and machinery space are to be non-combustible. The surface of insulation fitted on the internal boundaries of machinery spaces of category A is to be impervious to oil or oil vapours.

5.2.11 Within compartments used for stowage of fish, combustible insulation is to be protected by close-fitting cladding.

5.2.12 Notwithstanding the requirements of this sub-article, the Society may accept "A-0" class divisions in lieu of "B-15" class divisions, having regard to the amount of combustible materials used in adjacent spaces.

5.3 Ships of 24 m in length and over but less than 45 m

5.3.1 The decks and bulkheads separating machinery spaces of category A from accommodation spaces, service spaces or control stations are to be constructed to "A-60" Class standard where the machinery space of category A is not provided with a fixed fire-extinguishing system and to "A-0" Class standard where such a system is fitted. Decks and bulkheads separating other machinery spaces from accommodation, service spaces and control stations are to be constructed to "A-0" Class standard. Decks and bulkheads separating control stations from accommodation and service spaces are to be constructed to "B" Class standard, insulated to the satisfaction of the Society.

5.3.2

- a) The bulkheads of corridors serving accommodation spaces, service spaces or control stations are to be of "B-0" Class divisions.
- b) Any bulkhead of corridors serving accommodation spaces, services and central stations is to extend from deck to deck unless a continuous ceiling of the same Class as the bulkhead is fitted on both sides of the bulkhead, in which case the bulkhead can terminate at the continuous ceiling.

5.3.3 Interior stairways serving accommodation spaces, service spaces or control stations are to be of steel or other equivalent material. Such stairways connecting more than two decks are to be within enclosures constructed of "B-15" Class divisions.

5.3.4 Doors and other closures of openings in bulkheads and decks referred to in [5.3.1] and [5.3.2], doors fitted to stairway enclosures referred to in [5.3.3] and doors fitted in engine and boiler casings, are to be as far as practicable equivalent in resisting fire to the divisions in which they are fitted. Doors to machinery spaces of category A are to be self-closing.

5.3.5 Lift trunks, which pass through the accommodation and service spaces, are to be constructed of steel or equivalent material and are to be provided with means of closing which will permit control of draught and smoke.

5.3.6

- a) The boundary bulkheads and decks of spaces containing any emergency source of power and bulkheads and decks between galleys, paint rooms, lamp rooms or any store-rooms which contain appreciable quantities of highly flammable materials, and accommodation spaces, service spaces or control stations are to be of "A" Class divisions insulated to the satisfaction of the Society, having in mind the risk of fire, except that the Society may accept "B-15" Class divisions between galley and accommodation spaces, service spaces and control stations when the galley contains electrically heated furnaces, electrically heated hot water appliances or other electrically heated appliances only.
- b) Highly flammable products are to be carried in suitably sealed containers.

5.3.7 Where bulkheads or decks, required by [5.3.1], [5.3.2], [5.3.4] or [5.3.6] to be of "A" Class or "B" Class divisions, are penetrated for the passage of electrical cables, pipes, trunks, ducts, etc., arrangements are to be made to ensure that the fire integrity of the division is not impaired.

5.3.8 Air spaces enclosed behind ceilings, panellings or linings in accommodation spaces, service spaces and control stations are to be divided by close-fitting draught stops spaced not more than 7 m apart.

5.3.9 Windows and skylights to machinery spaces are to be as follows:

- a) Where skylights can be opened they are to be capable of being closed from outside the space. Skylights containing glass panels are to be fitted with external shutters of steel or other equivalent material permanently attached.
- b) Glass or similar materials are not to be fitted in machinery space boundaries. This does not preclude the use of wire-reinforced glass for skylights and glass in control rooms within the machinery spaces; and
- c) In skylights referred to in item a) wire-reinforced glass is to be used.

5.3.10 Insulating materials in accommodation spaces, service spaces except domestic refrigerating compartments, control stations and machinery space are to be non-combustible. The surface of insulation fitted on the internal boundaries of machinery spaces of category A is to be impervious to oil or oil vapours.

5.3.11 Within compartments used for stowage of fish, combustible insulation is to be protected by close-fitting cladding.

5.3.12 Notwithstanding the requirements of this sub-article, the Society may accept "A-0" class divisions in lieu of "B-15" class divisions, having regard to the amount of combustible materials used in adjacent spaces.

5.4 Ships of less than 24 m in length

5.4.1 If steel decks or steel bulkheads in accommodation form the top or side of a fuel oil tank, they are to be coated with a non-combustible material of thickness and density to the satisfaction of the Society. Manholes or other openings to fuel oil tanks are not to be positioned in the accommodation.

5.4.2 External bulkheads and ship's sides, which delimit the accommodation spaces, are to be insulated with an appropriate insulating material. Bulkheads between accommodation spaces and machinery spaces or cargo spaces are to be insulated with a non-combustible material of thickness and density to the satisfaction of the Society. The surface of insulation fitted on the internal boundaries of the machinery spaces of category A and in spaces into which oil products may penetrate is to be impervious to oil or oil vapours.

5.4.3 All insulation in accommodation spaces and the wheelhouse is to be made of non-combustible materials. Combustible insulation fitted in spaces used for the storage or processing of fish is to be protected by a tight non-combustible covering.

5.4.4 Where there is a door between the accommodation space and the machinery space, this door is to be a self-closing door of steel or equivalent. Doors between galley rooms and dining rooms might be permitted, provided they are made of fire-retardant material; the same applies to a serving hatch. Where only electric cooking appliances are used in the galley, the galley and the mess room could be seen as one common room, divided into two appropriate compartments.

6 Ventilation systems

6.1

6.1.1 Means are to be provided to stop fans and close main openings to ventilation systems from outside the spaces served.

6.1.2 Means are to be provided for closing, from a safe position, the annular spaces around funnels.

6.1.3 Ventilation openings may be permitted in and under the doors in corridor bulkheads except that such openings are not permitted in and under stairway enclosure doors. The openings are to be provided only in the lower half of a door. Where such opening is in or under a door, the total net area of any such opening or openings is not to exceed 0,05 m². When such opening is cut in a door, it is to be fitted with a grill made of non-combustible material.

6.1.4 Ventilation ducts for machinery spaces of category A or galleys are not in general to pass through accommodation spaces, service spaces or control stations. Where the Society permits this arrangement, the ducts are to be constructed of steel or equivalent material and arranged to preserve the integrity of the divisions.

6.1.5 Ventilation ducts of accommodation spaces, service spaces or control stations are not in general to pass through machinery spaces of category A or through galleys. Where the Society permits this arrangement, the ducts are to be constructed of steel or equivalent material and arranged to preserve the integrity of the divisions.

6.1.6 Storerooms containing appreciable quantities of highly flammable products are to be provided with ventilation arrangements, which are separate from other ventilation systems. Ventilation is to be arranged at high and low levels and the inlets and outlets of ventilators are to be positioned in safe areas. Suitable wire mesh guards to arrest sparks are to be fitted over inlet and outlet ventilation openings.

6.1.7 Ventilation systems serving machinery spaces are to be independent of systems serving other spaces.

6.1.8 Where ducts serve spaces on both sides of "A" Class bulkheads or decks, dampers are to be fitted so as to prevent the spread of smoke between compartments. Manual dampers are to be operable from both sides of the bulkhead or the deck. Where the ducts with a free cross-sectional area exceeding 0,02 m² pass through "A" Class bulkheads or decks, automatic self-closing dampers are to be fitted.

6.1.9 Where the ventilation ducts with a free cross-sectional area exceeding 0,02 m² pass through "A" Class bulkheads or decks, the opening is to be lined with a steel sheet sleeve, unless the ducts passing through the bulkheads or decks are of steel in the vicinity of passage through the deck or bulkhead and comply, in that portion of the duct, with the following:

- a) For ducts with a free cross-sectional area exceeding 0,02 m², the sleeves are to have a thickness of at least 3 mm and a length of at least 900 mm. When passing through bulkheads, this length is preferably to be divided evenly on each side of the bulkhead. Ducts with free cross-sectional area exceeding 0,02 m² are to be provided with fire insulation. The insulation is to

have at least the same fire integrity as the bulkhead or deck through which the duct passes. Equivalent penetration protection is to be provided to the satisfaction of the Society; and

- b) Ducts with a free cross-sectional area exceeding 0,075 m² are to be fitted with fire dampers in addition to the recommendations of item a). The fire damper is to operate automatically but is also to be capable of being closed manually from both sides of the bulkhead or deck. The damper is to be provided with an indicator which shows whether the damper is open or closed. Fire dampers are not required, however, where ducts pass through spaces surrounded by "A" Class divisions without serving those spaces, provided those ducts have the same fire integrity as the bulkheads which they penetrate.

6.1.10 Where they pass through accommodation spaces or spaces containing combustible materials, the exhaust ducts from galley ranges are to be constructed of "A" Class divisions. Each exhaust duct is to be fitted with:

- a grease trap readily removable for cleaning
- a fire damper located at the lower end of the duct
- arrangements, operable from within the galley, for shutting off the exhaust fans
- fixed means for extinguishing a fire within the duct.

The outlet ducts are to be easily accessible for cleaning.

7 Prevention of fire

7.1

7.1.1 The insulation of accommodation spaces, service spaces, control stations and machinery spaces is to consist of non-combustible material.

The insulation of refrigerated spaces and fish holds may consist of self-extinguishing materials, at the satisfaction of the Society.

7.1.2 Impervious linings and adhesives used for the insulation of refrigeration plants, as well as for the insulation of the related piping, may be of combustible materials, but their quantity is to be as limited as possible and their exposed surfaces are to have a resistance to the flame spread deemed satisfactory by the Society.

7.1.3 In spaces where penetration of oil products is possible, the surface of insulation is to be impervious to oil or oil vapours.

7.1.4 All exposed surfaces in accommodation spaces, service spaces, control stations, corridors, stairways trunks and associated hidden and inaccessible spaces behind bulkheads, ceilings, panels and linings are to have low flame spread characteristics.

7.1.5 Paints, varnishes and other finishes used on exposed interior surfaces are not to be capable of producing excessive quantities of smoke or toxic gases or vapours. The Society is to be satisfied that they are not of a nature to offer undue fire hazard.

7.1.6 Primary deck coverings within accommodation and service spaces and control stations are to be of approved material which will not readily ignite or give rise to toxic or explosive hazards at elevated temperatures.

7.1.7

- a) In accommodation and service spaces and control stations, pipes penetrating "A" or "B" Class divisions are to be of approved materials having regard to the temperature that such divisions are required to withstand. Where the Society permits the conveying of oil and combustible liquids through accommodation and service spaces, the pipes conveying oil or combustible liquids are to be of an approved material having regard to the fire risk.
- b) Materials readily rendered ineffective by heat are not to be used for overboard scuppers, sanitary discharges, and other outlets which are close to the waterline and where the failure of the material in the event of fire would give rise to danger of flooding.

7.1.8 All waste receptacles other than those used in fish processing are to be constructed of non-combustible materials with no openings in the sides and bottom.

7.1.9 Machinery driving fuel oil transfer pumps, oil fuel unit pumps and other similar fuel pumps are to be fitted with remote controls situated outside the space concerned so that they can be stopped in the event of a fire arising in the space in which they are located.

7.1.10 Drip trays are to be fitted where necessary to prevent oil leaking into bilges.

7.1.11 Electric heating appliances are to be so designed and installed as to reduce fire risks to a minimum. The decks and bulkheads on which they are installed are to be adequately protected with non-combustible material.

Heating appliances having exposed electrical parts or naked flame and stoves burning solid fuels are not permitted.

8 Means of escape

8.1

8.1.1 Stairways and ladders leading to and from all accommodation spaces and in spaces, in which the crew is normally employed, other than machinery spaces, are to be so arranged as to provide ready means of escape to the open deck and thence to the survival craft. In particular in relation to these spaces:

- a) at all levels of accommodation, at least two widely separated means of escape are to be provided which may include the normal means of access from each restricted space or group of spaces
- b)
 - below the weather deck, the means of escape is to be a stairway and the second escape may be a trunk or a stairway; and
 - above the weather deck, the means of escape are to be stairways or doors to an open deck or a combination thereof. Where it is not practicable to fit stairways or doors, one of these means of escape may be by means of adequately sized portholes or hatches protected where necessary against ice accretion
- c) exceptionally the Society may permit only one means of escape, due regard being paid to the nature and location of spaces and to the number of persons who normally might be accommodated or employed there
- d) a corridor or part of a corridor from which there is only one route of escape is preferably not to exceed 2,5 m in length and in no case to be greater than 5,0 m in length, and
- e) the width and continuity of the means of escape are to be to the satisfaction of the Society.

8.1.2 Two means of escape are to be provided from every machinery space of category A, which are to be as widely separated as possible. Vertical escapes are to be by means of steel ladders. Where the size of the machinery spaces makes it impracticable, one of these means of escape may be omitted. In such cases special consideration is to be given to the remaining exit.

8.1.3 Lifts are not to be considered as forming one of the required means of escape.

9 Fire detection

9.1

9.1.1 Where appreciable amounts of combustible materials are used on the construction of accommodation spaces, service spaces and control stations, special consideration is to be given to the installation of an automatic fire alarm and fire detection system in those spaces, having due regard to the size of those spaces, their arrangement and location relative to control stations as well as, where applicable, the flame-spread characteristics of the installed furniture.

10 Storage of gas cylinders and dangerous materials

10.1

10.1.1 Cylinders for compressed, liquefied or dissolved gases are to be clearly marked by means of prescribed identifying colours, are to have a clearly legible identification of the name and chemical formula of their contents and are to be properly secured.

10.1.2 Cylinders containing flammable or other dangerous gases and expended cylinders are to be stored, properly secured, on open decks and all valves, pressure regulators and pipes leading from such cylinders are to be protected against damage. Cylinders are to be protected against excessive variations in temperature, direct rays of the sun, and accumulation of snow. However, the Society may permit such cylinders to be stored in compartments complying with the requirements of [10.1.3] to [10.1.5].

10.1.3 Spaces containing highly flammable liquids, such as volatile paints, paraffin, benzole, etc., and, where permitted, liquefied gas are to have direct access from open decks only. Pressure-adjusting devices and relief valves are to exhaust within the compartment. Where boundary bulkheads of such compartments adjoin other enclosed spaces, they are to be gastight.

10.1.4 Except as necessary for service within the space, electrical wiring and fittings are not permitted within compartments used for the storage of highly flammable liquids or liquefied gases. Where such electrical fittings are installed, they are to be to the satisfaction of the Society for use in a flammable atmosphere. Sources of heat are to be kept clear of such spaces and "No Smoking" and "No Naked Light" notices are to be displayed in a prominent position.

10.1.5 Separate storage is to be provided for each type of compressed gas. Compartments used for the storage of such gases are not to be used for storage of other combustible products nor for tools or objects not part of the gas distribution system. However, the Society may relax these requirements considering the characteristics, volume and intended use of such compressed gases.

Part D

Service Notations

CHAPTER 16

OFFSHORE PATROL VESSELS

Section 1	General
Section 2	Stability
Section 3	Machinery
Section 4	Electricity and Automation
Section 5	Fire safety

Section 1 General

1 General

1.1 Application

1.1.1 Ships complying with the requirements of this Chapter are eligible for the assignment of the service notation **OPV**, as defined in Pt A, Ch 1, Sec 2, [4.7.1].

1.1.2 Requirements apply as a function of number of persons on board as defined in [1.2] and in any case the number of passengers as defined in [1.2.3] is limited to 12.

1.1.3 Ships dealt with in this Chapter are to comply with:

- Part A of the Rules
- NR216 Materials and Welding
- applicable requirements according to Tab 1.

1.1.4 References given in Tab 1 are specified for the use of technical criteria and do not mean the full adoption of referenced documents.

1.1.5 Attention is to be drawn on the possible additional requirements of the flag administration, if any.

1.2 Number of persons on board

1.2.1 The number of persons on board, N, is defined as the sum of:

- number of members of the crew
- number of special personnel, as defined in [1.2.2]
- number of passengers, as defined in [1.2.3], limited to 12.

Table 1 : Applicable requirements

Item		Greater than or equal to 500 GT	Less than 500 GT
Ship arrangement and hull integrity	$L \geq 90$ m	<ul style="list-style-type: none"> • Part B • Part C, Chapter 1 (1) 	<ul style="list-style-type: none"> • NR566 (2)
	$L < 90$ m	<ul style="list-style-type: none"> • NR600 • Part C, Chapter 1 (1) 	<ul style="list-style-type: none"> • NR566 (2)
Hull	$L \geq 90$ m	<ul style="list-style-type: none"> • Part B • NR396 (3) 	<ul style="list-style-type: none"> • Part B • NR396 (3)
	$L < 90$ m	<ul style="list-style-type: none"> • NR600 (2) 	<ul style="list-style-type: none"> • NR600 (2)
Stability		<ul style="list-style-type: none"> • NR566 • Ch 16, Sec 2 	<ul style="list-style-type: none"> • NR566 • Ch 16, Sec 2
Machinery		<ul style="list-style-type: none"> • Part C • Ch 16, Sec 3 	<ul style="list-style-type: none"> • NR566 (2) • Ch 16, Sec 3
Electrical installations and automation	$N \leq 60$ (4)	<ul style="list-style-type: none"> • Part C 	<ul style="list-style-type: none"> • NR566 (2)
	$N > 60$ (4)	<ul style="list-style-type: none"> • Part C • Ch 16, Sec 4 	<ul style="list-style-type: none"> • NR566 (2) • Ch 16, Sec 4
Fire protection, detection and extinction		<ul style="list-style-type: none"> • See Tab 2 	<ul style="list-style-type: none"> • See Tab 2

(1) Applicable requirements with respect to discharges and scuppers. see Pt C, Ch 1, Sec 10, [8].

(2) Application of these requirements are to be applied except that specific rules for passenger ships are not to be taken into account.

(3) In addition, requirements of NR396, Chapter 3 apply if $V \geq 7,16\Delta^{1/6}$ where V is the ship speed, in knots, and Δ is the displacement of the ship, in tons.

(4) The number of persons N is defined in [1.2].

Note 1:

NR396: Rules for the Classification of High Speed Craft.

NR566: Hull Arrangement, Stability and Systems for Ships less than 500 GT.

NR600: Hull Structure and Arrangement for the Classification of Cargo Ships less than 65 m and Non Cargo Ships less than 90 m.

1.2.2 Special personnel means all persons who are not passengers or members of the crew or children of under one year of age and who are carried on board in connection with the special purpose of that ship because of special work being carried out aboard that ship.

1.2.3 Passengers means every persons other than:

- The captain and the members of the crew or other persons employed or engaged in any capacity on board a ship on business of that ship and
- A child under one year of age.

Table 2 : Applicable requirements for fire safety

		Greater than 1000 GT	Between 500 and 1000 GT	Less than 500 GT	
				Unrestricted navigation	Restricted navigation
Steel or aluminium material	N ≤ 60	<ul style="list-style-type: none"> • Part C, Chapter 4 • Ch 16, Sec 5 	<ul style="list-style-type: none"> • NR566 	<ul style="list-style-type: none"> • NR566 	<ul style="list-style-type: none"> • NR566
	N >60 (1)	<ul style="list-style-type: none"> • Part C, Chapter 4 • Ch 16, Sec 5 	<ul style="list-style-type: none"> • Part C, Chapter 4 • Ch 16, Sec 5 	<ul style="list-style-type: none"> • Part C, Chapter 4 • Ch 16, Sec 5 	<ul style="list-style-type: none"> • NR566 • Ch 16, Sec 5
Composite material	N ≤ 60	NA (2)	<ul style="list-style-type: none"> • NR566 	<ul style="list-style-type: none"> • NR566 	<ul style="list-style-type: none"> • NR566
	N >60 (1)	NA (2)	NA (2)	NA (2)	<ul style="list-style-type: none"> • NR566 • Ch 16, Sec 5
<p>(1) Offshore patrol vessels with more than 200 persons will be subject to special consideration by the Society.</p> <p>(2) The present Chapter does not include this case (NA = not applicable).</p>					

Section 2 Stability

1 General

1.1 Application

1.1.1 Offshore patrol vessels may be assigned the service notation **OPV** only after it has been demonstrated that their stability is adequate.

Adequate stability means compliance with standards laid down by the relevant Administration or with the requirements specified in this Section.

In any case, the level of stability is not to be less than that provided by the Rules.

1.1.2 Intact stability

Ships granted with service notation **OPV** are to comply with:

- the provision of NR566, Ch 1, Sec 3, [2] regarding intact stability
- additional requirements of this Section, as applicable.

1.1.3 Damage stability

Damage stability should comply with provisions of NR566, Ch 1, Sec 3, [3] and additional requirements of this Section, as applicable, when at least one of the following conditions is met:

- the additional class notation **SDS** is granted
- the offshore patrol vessel is carrying more than 60 persons on board.

When damage stability is required, the additional class notation **SDS** is to be granted to the offshore patrol vessel.

In case a double bottom is not in accordance with the applicable rules then it is to be demonstrated that the ship is capable of withstanding bottom damages as per [3.2].

2 Intact Stability

2.1 Maximum turning angle

2.1.1 The angle of heel on account of turning may not exceed 10° when calculated using the following formula:

$$M_R = 0,02 V_0^2 \Delta \frac{(KG - T_1/2)}{L_{WL}}$$

where:

- M_R : heeling moment, in t.m
- V_0 : Maximum service speed, in m/s
- T_1 : Mean draught above the keel, in m
- KG : Height of centre of gravity above keel, in m
- L_{WL} : Length measured at waterline corresponding to mean draught T_1 .

2.2 Crowding angle for offshore patrol vessels carrying more than 60 persons

2.2.1 The angle of heel on account of crowding of persons to one side as defined below may not exceed 10°:

- A minimum weight of 75 kg is to be assumed for each person except that this value may be increased subject to the approval of the Society
- The height of the centre of gravity for person is to be assumed equal to 1m above deck level for person standing upright
- Persons are to be considered as distributed to produce the most unfavourable combination of person heeling moment and/or initial metacentric height, which may be obtained in practice. In this connection, a value higher than four persons per square meter is not necessary.

3 Damage stability

3.1 Offshore patrol vessels carrying more than 60 persons

3.1.1 Application of requirements in NR566, Ch1, Sec3, [3] where the ship is considered as a passenger ship. However the requirement regarding the margin line is not to be considered.

3.2 Bottom damages

3.2.1 Bottom damage stability should comply with provision of NR566, Ch 1, Sec 3, [3] assuming bottom damages at any position along the ship's bottom and with an extent specified in Tab 1.

4 Damage control documentation for ships greater than or equal to 500 GT

4.1

4.1.1 The damage control documentation is to be submitted.

Table 1 : Assumed extent of damage

	For 0,3 L from the forward perpendicular of the ship	Any other part of the ship
Longitudinal extent	$1/3 L^{2/3}$ or 14,5 m, whichever is less	$1/3 L^{2/3}$ or 14,5 m, whichever is less
Transverse extent	B/6 or 10 m, whichever is less	B/6 or 5 m, whichever is less
Vertical extent, measured from the keel line	B/20 or 2 m, whichever is less	B/20 or 2 m, whichever is less

Section 3 Machinery

1 General

1.1 Application

1.1.1 This Section concerns specific requirements regarding:

- Capacity of service tanks for offshore patrol vessels with $GT \geq 500$
- Bilge pumping arrangement and prevention for progressive flooding for ship where damage stability is required in accordance with Ch 16, Sec 2, [1.1.3].

1.2 Capacity of service tanks for offshore patrol vessels with $GT \geq 500$

1.2.1 Notwithstanding Pt C, Ch 1, Sec 10, [11.9.2], items b), c) and d), the capacity of service tanks should comply with NR566, Ch 2, Sec 6, [4.2.2], Note 2 excluded.

1.3 Progressive flooding

1.3.1 Application

Requirements [1.3.2] and [1.3.3] apply for offshore vessels for which damage stability is required.

1.3.2 Offshore patrol vessels with $GT \geq 500$

Pt C, Ch 1, Sec 10, [5.5] is to be replaced by NR566, Ch 2, Sec 4, [5.9].

1.3.3 Offshore patrol vessels with $GT < 500$

Requirements as stated in NR566, Ch 2, Sec 4, [5.9] should apply.

1.4 Bilge pumping after flooding

1.4.1 Application

Requirements [1.4.2] and [1.4.3] apply for offshore vessels carrying more than 60 persons, for which damage stability is required.

1.4.2 Offshore patrol vessels with $GT \geq 500$

In addition to the requirements as stated in Pt C, Ch 1, Sec 10, [6], provision of NR566, Ch 2, Sec 5, [1.6] should apply.

1.4.3 Offshore patrol vessels with $GT < 500$

Requirements as stated in NR566, Ch 2, Sec 5, [1.6] should apply.

Section 4 Electricity and Automation

1 General

1.1 Application

1.1.1 The requirements in this Section apply to offshore patrol vessels carrying more than 60 persons.

1.2 General alarm for ships with $GT < 500$

1.2.1 In addition to the requirements required in NR566, Ch 3, Sec 2, [3.11.1], the following requirements in NR566, Ch 3, Sec 2, [3.11.2], item b), should apply.

1.3 Emergency source of electrical power for ships with $GT \geq 500$

1.3.1 Notwithstanding Pt C, Ch 2, Sec 3, [2.3.13], items b) and c), where the emergency source of electrical power is a generator, it shall be started automatically upon failure of the electrical power supply to the emergency switchboard and shall be automatically connected to the services referred in Pt C, Ch 2, Sec 3, [3.6.7]. The automatic starting system and the characteristics of the prime mover shall be such as to permit the emergency generator to carry its full rated load as quickly as is safe and practicable, subject to a maximum of 45 s.

In addition, a transitional source of emergency electrical power as specified in Pt C, Ch 2, Sec 3, [2.3.16] is to be provided in all cases when the emergency source of power is a generator.

1.4 Public address system for ships with $GT \geq 500$

1.4.1 Where the public address system is used to supplement the general emergency alarm system as per Pt C, Ch 2, Sec 3, [3.14.2], it is to be arranged to operate on the main source of electrical power, the emergency source of electrical power and the transitional source of electrical power as required in [1.3] and Pt C, Ch 2, Sec 3, [3.6].

Section 5 Fire safety

1 General

1.1 Application

1.1.1 The applicable requirements are defined in Ch 16, Sec 1, Tab 2.

Part C, Chapter 4 and Rule Note NR566 are to be applied except that specific rules for passenger ships are not to be taken into account.

1.1.2 Fire safety of offshore patrol vessels carrying more than 200 persons will be subject to special consideration by the Society.

2 Materials

2.1 Steel or equivalent

2.1.1 In case the application of Part C, Chapter 4 is required, all indications “steel” (without the extension “or equivalent”) in these rules, can be replaced by “steel or equivalent”.

2.1.2 In case the application of Part C, Chapter 4 is required, aluminium bulkheads are generally to be insulated on both sides. However, if one of the two spaces have little or no fire risk such as voids, sanitary spaces, carbon dioxide rooms and similar spaces, insulation need only to be applied on the side that is exposed to the greatest fire risk.

3 Specific requirements

3.1 Offshore patrol vessels carrying more than 60 persons

3.1.1 For offshore patrol vessels carrying more than 60 persons and when the application of NR566 is authorised, the following additional rules apply:

- exposed surfaces of bulkheads, walls, linings and ceilings in accommodation and service spaces and control stations are to be low flame spread
- remote starting of one fire pump is to be provided from wheel house.

3.2 Ammunition storage compartments

3.2.1 The protection of ammunition storage compartments will be subject to special consideration by the Society. Applicable rules will be based on a common agreement with the shipowner and the shipyard, including aspects of fire detection, structural fire integrity, ventilation, fire fighting and electrical equipment protection.



BUREAU VERITAS MARINE & OFFSHORE

1 place Zaha Hadid
CS 40381
92062 Paris La Défense Cedex - France
+33 (0)1 55 24 70 00

marine-offshore.bureauveritas.com/rules-guidelines

© 2023 BUREAU VERITAS - All rights reserved



**BUREAU
VERITAS**

Shaping a World of Trust