



**BUREAU
VERITAS**

Rules for the Classification of Steel Ships

PART E – Service Notations for Offshore Service Vessels and Tugs

NR 467.E1 DT R02 E

July 2019

Marine & Offshore
Le Triangle de l'Arche - 8 cours du Triangle - CS50101
92937 Paris la Défense Cedex- France
Tel: + 33 (0)1 55 24 70 00
<https://marine-offshore.bureauveritas.com/bv-rules>
© 2019 Bureau Veritas - All rights reserved



GENERAL CONDITIONS

1. INDEPENDENCE OF THE SOCIETY AND APPLICABLE TERMS

- 1.1 The Society shall remain at all times an independent contractor and neither the Society nor any of its officers, employees, servants, agents or subcontractors shall be or act as an employee, servant or agent of any other party hereto in the performance of the Services.
- 1.2 The operations of the Society in providing its Services are exclusively conducted by way of random inspections and do not, in any circumstances, involve monitoring or exhaustive verification.
- 1.3 The Society acts as a services provider. This cannot be construed as an obligation bearing on the Society to obtain a result or as a warranty. The Society is not and may not be considered as an underwriter, broker in Unit's sale or chartering, expert in Unit's valuation, consulting engineer, controller, naval architect, designer, manufacturer, shipbuilder, repair or conversion yard, charterer or shipowner; none of them above listed being relieved of any of their expressed or implied obligations as a result of the interventions of the Society.
- 1.4 The Society only is qualified to apply and interpret its Rules.
- 1.5 The Client acknowledges the latest versions of the Conditions and of the applicable Rules applying to the Services' performance.
- 1.6 Unless an express written agreement is made between the Parties on the applicable Rules, the applicable Rules shall be the Rules applicable at the time of entering into the relevant contract for the performance of the Services.
- 1.7 The Services' performance is solely based on the Conditions. No other terms shall apply whether express or implied.

2. DEFINITIONS

- 2.1 "Certificate(s)" means classification or statutory certificates, attestations and reports following the Society's intervention.
- 2.2 "Certification" means the activity of certification in application of national and international regulations or standards, in particular by delegation from different governments that can result in the issuance of a Certificate.
- 2.3 "Classification" means the classification of a Unit that can result or not in the issuance of a classification Certificate with reference to the Rules. Classification is an appraisal given by the Society to the Client, at a certain date, following surveys by its surveyors on the level of compliance of the Unit to the Society's Rules or to the documents of reference for the Services provided. They cannot be construed as an implied or express warranty of safety, fitness for the purpose, seaworthiness of the Unit or of its value for sale, insurance or chartering.
- 2.4 "Client" means the Party and/or its representative requesting the Services.
- 2.5 "Conditions" means the terms and conditions set out in the present document.
- 2.6 "Industry Practice" means international maritime and/or offshore industry practices.
- 2.7 "Intellectual Property" means all patents, rights to inventions, utility models, copyright and related rights, trade marks, logos, service marks, trade dress, business and domain names, rights in trade dress or get-up, rights in goodwill or to sue for passing off, unfair competition rights, rights in designs, rights in computer software, database rights, topography rights, moral rights, rights in confidential information (including know-how and trade secrets), methods and protocols for Services, and any other intellectual property rights, in each case whether capable of registration, registered or unregistered and including all applications for and renewals, reversions or extensions of such rights, and all similar or equivalent rights or forms of protection in any part of the world.
- 2.8 "Parties" means the Society and Client together.
- 2.9 "Party" means the Society or the Client.
- 2.10 "Register" means the public electronic register of ships updated regularly by the Society.
- 2.11 "Rules" means the Society's classification rules and other documents. The Society's Rules take into account at the date of their preparation the state of currently available and proven technical minimum requirements but are not a standard or a code of construction neither a guide for maintenance, a safety handbook or a guide of professional practices, all of which are assumed to be known in detail and carefully followed at all times by the Client.
- 2.12 "Services" means the services set out in clauses 2.2 and 2.3 but also other services related to Classification and Certification such as, but not limited to: ship and company safety management certification, ship and port security certification, maritime labour certification, training activities, all activities and duties incidental thereto such as documentation on any supporting means, software, instrumentation, measurements, tests and trials on board. The Services are carried out by the Society according to the applicable referential and to the Bureau Veritas' Code of Ethics. The Society shall perform the Services according to the applicable national and international standards and Industry Practice and always on the assumption that the Client is aware of such standards and Industry Practice.
- 2.13 "Society" means the classification society "Bureau Veritas Marine & Offshore SAS", a company organized and existing under the laws of France, registered in Nanterre under number 821 131 844, or any other legal entity of Bureau Veritas Group as may be specified in the relevant contract, and whose main activities are Classification and Certification of ships or offshore units.
- 2.14 "Unit" means any ship or vessel or offshore unit or structure of any type or part of it or system whether linked to shore, river bed or sea bed or not, whether operated or located at sea or in inland waters or partly on land, including submarines, hovercrafts, drilling rigs, offshore installations of any type and of any purpose, their related and ancillary equipment, subsea or not, such as well head and pipelines, mooring legs and mooring points or otherwise as decided by the Society.

3. SCOPE AND PERFORMANCE

- 3.1 Subject to the Services requested and always by reference to the Rules, the Society shall:
 - review the construction arrangements of the Unit as shown on the documents provided by the Client;
 - conduct the Unit surveys at the place of the Unit construction;
 - class the Unit and enter the Unit's class in the Society's Register;
 - survey the Unit periodically in service to note whether the requirements for the maintenance of class are met.The Client shall inform the Society without delay of any circumstances which may cause any changes on the conducted surveys or Services.
- 3.2 The Society will not:
 - declare the acceptance or commissioning of a Unit, nor its construction in conformity with its design, such activities remaining under the exclusive responsibility of the Unit's owner or builder;
 - engage in any work relating to the design, construction, production or repair checks, neither in the operation of the Unit or the Unit's trade, neither in any advisory services, and cannot be held liable on those accounts.

4. RESERVATION CLAUSE

- 4.1 The Client shall always: (i) maintain the Unit in good condition after surveys; (ii) present the Unit for surveys; and (iii) inform the Society in due time of any circumstances that may affect the given appraisal of the Unit or cause to modify the scope of the Services.
- 4.2 Certificates are only valid if issued by the Society.
- 4.3 The Society has entire control over the Certificates issued and may at any time withdraw a Certificate at its entire discretion including, but not limited to, in the following situations: where the Client fails to comply in due time with instructions of the Society or where the Client fails to pay in accordance with clause 6.2 hereunder.
- 4.4 The Society may at times and at its sole discretion give an opinion on a design or any technical element that would 'in principle' be acceptable to the Society. This opinion shall not presume on the final issuance of any Certificate or on its content in the event of the actual issuance of a Certificate. This opinion shall only be an appraisal made by the Society which shall not be held liable for it.

5. ACCESS AND SAFETY

- 5.1 The Client shall give to the Society all access and information necessary for the efficient performance of the requested Services. The Client shall be the sole responsible for the conditions of presentation of the Unit for tests, trials and surveys and the conditions under which tests and trials are carried out. Any information, drawing, etc. required for the performance of the Services must be made available in due time.
- 5.2 The Client shall notify the Society of any relevant safety issue and shall take all necessary safety-related measures to ensure a safe work environment for the Society or any of its officers, employees, servants, agents or subcontractors and shall comply with all applicable safety regulations.

6. PAYMENT OF INVOICES

- 6.1 The provision of the Services by the Society, whether complete or not, involve, for the part carried out, the payment of fees thirty (30) days upon issuance of the invoice.

6.2 Without prejudice to any other rights hereunder, in case of Client's payment default, the Society shall be entitled to charge, in addition to the amount not properly paid, interests equal to twelve (12) months LIBOR plus two (2) per cent as of due date calculated on the number of days such payment is delinquent. The Society shall also have the right to withhold Certificates and other documents and/or to suspend or revoke the validity of Certificates.

6.3 In case of dispute on the invoice amount, the undisputed portion of the invoice shall be paid and an explanation on the dispute shall accompany payment so that action can be taken to solve the dispute.

7. LIABILITY

- 7.1 The Society bears no liability for consequential loss. For the purpose of this clause consequential loss shall include, without limitation:
 - Indirect or consequential loss;
 - Any loss and/or deferral of production, loss of product, loss of use, loss of bargain, loss of revenue, loss of profit or anticipated profit, loss of business and business interruption, in each case whether direct or indirect.The Client shall defend, release, save, indemnify, defend and hold harmless the Society from the Client's own consequential loss regardless of cause.
- 7.2 Except in case of wilful misconduct of the Society, death or bodily injury caused by the Society's negligence and any other liability that could not be, by law, limited, the Society's maximum liability towards the Client is limited to one hundred and fifty per-cents (150%) of the price paid by the Client to the Society for the Services having caused the damage. This limit applies to any liability of whatsoever nature and howsoever arising, including fault by the Society, breach of contract, breach of warranty, tort, strict liability, breach of statute.
- 7.3 All claims shall be presented to the Society in writing within three (3) months of the completion of Services' performance or (if later) the date when the events which are relied on were first discovered by the Client. Any claim not so presented as defined above shall be deemed waived and absolutely time barred.

8. INDEMNITY CLAUSE

8.1 The Client shall defend, release, save, indemnify and hold harmless the Society from and against any and all claims, demands, lawsuits or actions for damages, including legal fees, for harm or loss to persons and/or property tangible, intangible or otherwise which may be brought against the Society, incidental to, arising out of or in connection with the performance of the Services (including for damages arising out of or in connection with opinions delivered according to clause 4.4 above) except for those claims caused solely and completely by the gross negligence of the Society, its officers, employees, servants, agents or subcontractors.

9. TERMINATION

- 9.1 The Parties shall have the right to terminate the Services (and the relevant contract) for convenience after giving the other Party thirty (30) days' written notice, and without prejudice to clause 6 above.
- 9.2 In such a case, the Classification granted to the concerned Unit and the previously issued Certificates shall remain valid until the date of effect of the termination notice issued, subject to compliance with clause 4.1 and 6 above.
- 9.3 In the event where, in the reasonable opinion of the Society, the Client is in breach, or is suspected to be in breach of clause 16 of the Conditions, the Society shall have the right to terminate the Services (and the relevant contracts associated) with immediate effect.

10. FORCE MAJEURE

- 10.1 Neither Party shall be responsible or liable for any failure to fulfil any term or provision of the Conditions if and to the extent that fulfilment has been delayed or temporarily prevented by a force majeure occurrence without the fault or negligence of the Party affected and which, by the exercise of reasonable diligence, the said Party is unable to provide against.
- 10.2 For the purpose of this clause, force majeure shall mean any circumstance not being within a Party's reasonable control including, but not limited to: acts of God, natural disasters, epidemics or pandemics, wars, terrorist attacks, riots, sabotages, impositions of sanctions, embargoes, nuclear, chemical or biological contaminations, laws or action taken by a government or public authority, quotas or prohibition, expropriations, destructions of the worksite, explosions, fires, accidents, any labour or trade disputes, strikes or lockouts.

11. CONFIDENTIALITY

- 11.1 The documents and data provided to or prepared by the Society in performing the Services, and the information made available to the Society, are treated as confidential except where the information:
 - is properly and lawfully in the possession of the Society;
 - is already in possession of the public or has entered the public domain, otherwise than through a breach of this obligation;
 - is acquired or received independently from a third party that has the right to disseminate such information;
 - is required to be disclosed under applicable law or by a governmental order, decree, regulation or rule or by a stock exchange authority (provided that the receiving Party shall make all reasonable efforts to give prompt written notice to the disclosing Party prior to such disclosure).
- 11.2 The Parties shall use the confidential information exclusively within the framework of their activity underlying these Conditions.
- 11.3 Confidential information shall only be provided to third parties with the prior written consent of the other Party. However, such prior consent shall not be required when the Society provides the confidential information to a subsidiary.
- 11.4 Without prejudice to sub-clause 11.1, the Society shall have the right to disclose the confidential information if required to do so under regulations of the International Association of Classifications Societies (IACS) or any statutory obligations.

12. INTELLECTUAL PROPERTY

- 12.1 Each Party exclusively owns all rights to its Intellectual Property created before or after the commencement date of the Conditions and whether or not associated with any contract between the Parties.
- 12.2 The Intellectual Property developed by the Society for the performance of the Services including, but not limited to drawings, calculations, and reports shall remain the exclusive property of the Society.

13. ASSIGNMENT

- 13.1 The contract resulting from these Conditions cannot be assigned or transferred by any means by a Party to any third party without the prior written consent of the other Party.
- 13.2 The Society shall however have the right to assign or transfer by any means the said contract to a subsidiary of the Bureau Veritas Group.

14. SEVERABILITY

- 14.1 Invalidity of one or more provisions does not affect the remaining provisions.
- 14.2 Definitions herein take precedence over other definitions which may appear in other documents issued by the Society.
- 14.3 In case of doubt as to the interpretation of the Conditions, the English text shall prevail.

15. GOVERNING LAW AND DISPUTE RESOLUTION

- 15.1 These Conditions shall be construed and governed by the laws of England and Wales.
- 15.2 The Parties shall make every effort to settle any dispute amicably and in good faith by way of negotiation within thirty (30) days from the date of receipt by either one of the Parties of a written notice of such a dispute.
- 15.3 Failing that, the dispute shall finally be settled under the Rules of Arbitration of the Maritime Arbitration Chamber of Paris ("CAMP"), which rules are deemed to be incorporated by reference into this clause. The number of arbitrators shall be three (3). The place of arbitration shall be Paris (France). The Parties agree to keep the arbitration proceedings confidential.

16. PROFESSIONAL ETHICS

- 16.1 Each Party shall conduct all activities in compliance with all laws, statutes, rules, economic and trade sanctions (including but not limited to US sanctions and EU sanctions) and regulations applicable to such Party including but not limited to: child labour, forced labour, collective bargaining, discrimination, abuse, working hours and minimum wages, anti-bribery, anti-corruption, copyright and trademark protection, personal data protection (<https://personaldataprotection.bureauveritas.com/privacypolicy>).
- Each of the Parties warrants that neither it, nor its affiliates, has made or will make, with respect to the matters provided for hereunder, any offer, payment, gift or authorization of the payment of any money directly or indirectly, to or for the use or benefit of any official or employee of the government, political party, official, or candidate.
- 16.2 In addition, the Client shall act consistently with the Bureau Veritas' Code of Ethics. <https://group.bureauveritas.com/group/corporate-social-responsibility>

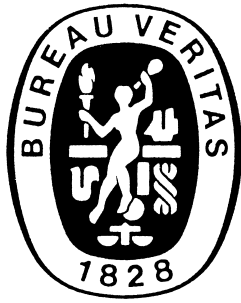

RULES FOR THE CLASSIFICATION OF SHIPS

Part E Service Notations for Offshore Service Vessels and Tugs

Chapters **1 2 3 4 5 6 7 8 9 10 11 12**

Chapter 1	TUGS
Chapter 2	ANCHOR HANDLING VESSELS
Chapter 3	SUPPLY VESSELS
Chapter 4	FIRE FIGHTING SHIPS
Chapter 5	OIL RECOVERY SHIPS
Chapter 6	CABLE-LAYING SHIPS
Chapter 7	DIVING SUPPORT VESSELS
Chapter 8	LIFTING UNITS
Chapter 9	SEMI-SUBMERSIBLE CARGO SHIPS
Chapter 10	STANDBY RESCUE VESSELS
Chapter 11	ACCOMMODATION UNITS
Chapter 12	PIPE LAYING UNITS

The English wording of these rules take precedence over editions in other languages.

Unless otherwise specified, these rules apply to ships for which contracts are signed after July 1st, 2019. The Society may refer to the contents hereof before July 1st, 2019, as and when deemed necessary or appropriate.

CHAPTER 1

TUGS

Section 1 General

1	General	31
1.1	Application	
2	Definitions	31
2.1	Design bollard pull	
2.2	Reference towline force	
2.3	Design load	
2.4	Winch brake holding load	
2.5	Towline breaking strength	
2.6	Escort tugs indirect towing modes	
2.7	Escort forces and speed	
3	Fire safety	34
3.1	Suppression of fire	

Section 2 Stability

1	Application	35
1.1		
2	Openings	35
2.1	General	
3	General requirements	35
3.1	Intact stability	
4	Additional requirements for escort tugs	36
4.1	Intact stability	
4.2	Inclinometer	

Section 3 Hull Structure

1	General	39
1.1	Application	
1.2	Documents to be submitted	
2	General requirements	39
2.1	Typical design arrangements	
2.2	Structure design principles	
2.3	Hull scantlings	
2.4	Other structures	
2.5	Rudder and bulwarks	
2.6	Anchoring and mooring equipment	
2.7	Towing equipment	

3	Additional requirements for escort tugs	44
3.1	Structural design principles	
3.2	Equipment for escort operations	
4	Additional requirements for salvage tugs	46
4.1	Equipment	

Section 4 Integrated Tug/Barge Combination

1	General	47
1.1	Application	
1.2	Permanent connections	
1.3	Removable connections	
1.4	Documents to be submitted	
2	General arrangement design	47
2.1	Bulkhead arrangement	
3	Integrated tug/barge combinations with permanent connection: stability, freeboard, design loads, hull scantlings and equipment	48
3.1	Stability calculations	
3.2	Freeboard calculation	
3.3	Still water hull girder loads	
3.4	Wave hull girder loads	
3.5	Still water local loads	
3.6	Wave local loads	
3.7	Hull girder strength	
3.8	Scantlings of plating, ordinary stiffeners and primary supporting members	
3.9	Equipment	
4	Integrated tug/barge combination with removable connection: stability, freeboard, design loads, hull scantlings and equipment	49
4.1	Stability calculations	
4.2	Freeboard calculation	
4.3	Still water hull girder loads	
4.4	Wave hull girder loads	
4.5	Still water local loads	
4.6	Wave local loads	
4.7	Hull girder strength	
4.8	Scantlings of plating, ordinary stiffeners and primary supporting members	
4.9	Equipment	
5	Connection	50
5.1	General	
5.2	Scantlings	
6	Other structures	50
6.1	Tug fore part	
6.2	Tug aft part	
6.3	Barge fore part	
6.4	Barge aft part	
7	Hull outfitting	51
7.1	Rudder and steering gear	

8	Construction and testing	51
---	--------------------------	----

8.1	Test of the disconnection procedure of removable connection	
-----	---	--

Section 5 Testing

1	General	52
---	---------	----

1.1	Application	
-----	-------------	--

2	General requirements	52
---	----------------------	----

2.1	Bollard Pull test	
2.2	Towing winches	
2.3	Towing hooks	
2.4	Emergency release system	

3	Additional requirements for escort tugs	53
---	---	----

3.1	Escort performance simulations	
3.2	Escort performance trials	
3.3	Escort equipment testing	

CHAPTER 2

ANCHOR HANDLING VESSELS

Section 1 General

1	General	59
1.1	Application	
1.2	Definitions	

Section 2 Stability

1	General	60
1.1	Operational procedures	
2	Stability	60
2.1	General	
2.2	Assumptions	
2.3	Heeling moment	
2.4	Intact stability	
2.5	Information to be displayed	
2.6	Stability booklet	

Section 3 Hull Structure

1	Documentation	65
1.1	Documents to be submitted	
2	General requirements	66
2.1	Deck equipment	
2.2	Loading manual	
2.3	Design loads	
2.4	Deck structure	
2.5	Anchor handling winch	
2.6	Anchor handling deck equipment other than winches	
2.7	Stern roller	
2.8	Wire	

Section 4 Testing

1	General	68
1.1	Load test	
1.2	Functional test	
1.3	Operational tests	

CHAPTER 3

SUPPLY VESSELS

Section 1 General

1	General	71
1.1	Application	
1.2	IMO regulations	
1.3	Classification notations	
1.4	Applicable rules	
1.5	Definitions	
2	Documents to be submitted	75
2.1	General	

Section 2 General Arrangement

1	Compartment arrangement	77
1.1	General	
1.2	Additional requirements for ships granted with HNLS and/or WELLSTIM additional service features	
1.3	Compartment arrangement in way of oil product cargo tanks	
2	Arrangement and access to spaces	78
2.1	Access arrangement in way of cargo tanks for oil products	
2.2	Additional requirements for ships granted with HNLS and/or WELLSTIM additional service features	
3	Arrangement for hull and forecastle openings	79
3.1	General	

Section 3 Stability

1	General	80
1.1	Application	
1.2	Relaxation	
1.3	Additional requirements for ships granted with HNLS and/or WELLSTIM additional service features	
2	Intact stability	80
2.1	General	
2.2	Additional requirements for ships granted with HNLS and/or WELLSTIM additional service features	
3	Damage stability	81
3.1	Damage stability when the additional class notation SDS is assigned	

Section 4 Hull Structure

1	Structure design principles	83
1.1	General	
1.2	Side structure exposed to bumping	
1.3	Deck structure	
1.4	Structure of cement tanks and mud compartments	
1.5	Additional requirements for ships granted with HNLS and/or WELLSTIM additional service features	
1.6	Additional requirements for ships granted with notation -acids	
2	Design loads	83
2.1	Dry uniform cargoes	
3	Hull scantlings	83
3.1	Plating	
3.2	Ordinary stiffeners	
3.3	Primary supporting members	
4	Other structure	84
4.1	Aft part	
4.2	Superstructures and deckhouses	
4.3	Structure of cargo tanks	
5	Hull outfitting	85
5.1	Rudders	
5.2	Bulwarks	
5.3	Equipment	

Section 5 Machinery and Cargo Systems

1	Machinery systems	86
1.1	Cargo heating systems	
1.2	Exhaust pipes	
1.3	Inert gas system	
1.4	Other machinery systems	
1.5	Additional requirements for ships granted with HNLS and/or WELLSTIM additional service features	
1.6	Additional requirements for ships granted with notations -FP≤60°C and/or -acids and/or -toxic	
1.7	Additional requirements for ships granted with notation -FP≤60°C	
1.8	Additional requirements for ships granted with notation -toxic	
1.9	Additional requirements for ships granted with notation -acids	
2	Cargo piping design	86
2.1	Cargo separation	
2.2	Design and materials	
2.3	Piping arrangement	
2.4	Additional requirements for ships granted with HNLS and/or WELLSTIM additional service features	
2.5	Additional requirements for ships granted with notations -FP≤60°C and/or -acids and/or -toxic	

3	Cargo tanks	87
3.1	Cargo oil tanks	
3.2	Additional requirements for ships granted with HNLS and/or WELLSTIM additional service features	
4	Cargo pumping system	87
4.1	General	
5	Cargo tank fittings	88
5.1	Level gauging systems and overflow control	
5.2	Cargo tank venting systems	
5.3	Additional requirements for ships granted with HNLS and/or WELLSTIM additional service features	
5.4	Additional requirements for ships granted with notation -toxic	
5.5	Additional requirements for ships granted with notation -acids	
6	Mechanical ventilation in the cargo area	89
6.1	Cargo pump-room ventilation	
6.2	Additional requirements for ships granted with HNLS and/or WELLSTIM additional service features	
7	Discharging and loading of portable tanks on board	89
7.1	Ships granted with additional service features HNLS and/or WELLSTIM	
8	Additional requirements for carriage of liquid carbon dioxide and liquid nitrogen	89
8.1	Ships granted with notation -LG	

Section 6 Electrical Installations, Instrumentation and Automation

1	Hazardous location and types of equipment	91
1.1	General	
2	Additional requirements for ships granted with HNLS and/or WELLSTIM additional service features	91
2.1	General	
2.2	Additional requirements for ships granted with notations -FP≤60°C and/or -toxic	
2.3	Additional requirements for ships granted with notation -acid	

Section 7 Fire Prevention, Protection and Extinction

1	General	92
1.1	Application	
2	Fire prevention and protection	92
2.1	Ships granted with additional service features HNLS and/or WELLSTIM	
3	Fire fighting	92
3.1	Ships carrying oil product	
3.2	Ships granted with additional service features HNLS and/or WELLSTIM	
4	Personnel protection	92
4.1	Ships carrying oil products	
4.2	Ships granted with additional service features HNLS and/or WELLSTIM	
4.3	Additional requirements for ships granted with notation -LG	

CHAPTER 4

FIRE FIGHTING SHIPS

Section 1 General

1	General	95
	1.1 Application	

Section 2 Hull and Stability

1	Stability	96
	1.1 Intact stability	
2	Structure design principles	96
	2.1 Hull structure	
	2.2 Water and foam monitors	
3	Other structures	96
	3.1 Arrangement for hull and superstructure openings	

Section 3 Machinery and Systems

1	General	97
	1.1 Application	
	1.2 Documents to be submitted	
2	Design of machinery systems	97
	2.1 Manoeuvrability	
	2.2 Fuel oil capacity	
	2.3 Scuppers	
3	General requirements for fire-fighting systems	98
	3.1 General	
	3.2 Independence of pumping and piping systems	
	3.3 Design and construction of piping systems	
	3.4 Monitors	
	3.5 Monitor control	
4	Water fire-fighting system	99
	4.1 Characteristics	
	4.2 Monitors	
	4.3 Piping	
5	Fixed foam fire-extinguishing system	100
	5.1 General	
	5.2 Characteristics	
	5.3 Arrangement	
6	Portable fire-fighting equipment	100
	6.1 Portable high expansion foam generator	
	6.2 Hydrants and fire hoses	

7	Firemen's outfits	101
	7.1 Number and characteristics	
	7.2 Compressed air system for breathing apparatuses	
8	Testing	101
	8.1 General	
	8.2 Workshop tests	
	8.3 On board tests	

Section 4 Fire Protection and Extinction

1	General	103
	1.1 Application	
	1.2 Documents to be submitted	
2	Fire protection of exposed surfaces	103
	2.1 Structural fire protection	
	2.2 Deadlights and shutters	
3	Self-protection water-spraying system	103
	3.1 General	
	3.2 Capacity	
	3.3 Arrangement	
	3.4 Pumps	
	3.5 Piping system and spray nozzles	

CHAPTER 5

OIL RECOVERY SHIPS

Section 1 General

1	General	107
	1.1 Application	
	1.2 Definitions	

Section 2 Hull and Stability

1	General	109
	1.1 Documents to be submitted	
	1.2 General arrangement	
2	Stability	110
	2.1 Intact stability	
3	Hull scantlings	110
	3.1 Additional loads	
4	Construction and testing	110
	4.1 Testing	

Section 3 Machinery and Systems

1	General	111
	1.1 Documents to be submitted	
2	Machinery installation and piping system other than oil recovery system	111
	2.1 Sea water cooling system	
	2.2 Water fire-extinguishing system	
	2.3 Exhaust gas systems	
3	Pumping system, piping system and pump-rooms intended for recovered oil	111
	3.1 Design of pumping and piping systems	
	3.2 Arrangement of piping systems	
	3.3 Oil recovery pumps	
	3.4 Oil recovery pump-rooms	
4	Oil recovery tank fittings	112
	4.1 Vent pipes	
	4.2 Level gauging and overfilling control	
5	Heating systems	113
	5.1	
6	Additional requirements	113
	6.1 Ships assigned with the additional service feature OILTREAT	

Section 4 Electrical Installations

1	General	114
	1.1 Application	
	1.2 Documentation to be submitted	
2	Design requirements	114
	2.1 System of supply	
	2.2 Earth detection	
3	Hazardous locations and types of equipment	114
	3.1 Electrical equipment permitted in hazardous areas	
	3.2 Additional requirements for machinery installations in hazardous areas	
	3.3 Openings, access and ventilation conditions affecting the extent of hazardous areas	

Section 5 Fire Protection, Detection and Extinction

1	General	116
	1.1 Documents to be submitted	
2	Mechanical ventilation in the oil recovery area	116
	2.1 General	
	2.2 Ventilation of recovered oil pump rooms	
	2.3 Ventilation of enclosed spaces normally entered during oil recovery operation other than recovery oil pump rooms	
3	Fire protection and fighting	116
	3.1 Vapor detector	
	3.2 Structural fire protection	
	3.3 Fire-fighting	

CHAPTER 6

CABLE-LAYING SHIPS

Section 1 General

1	General	121
1.1	Application	

Section 2 Hull and Stability

1	General	122
1.1	Application	
1.2	Documents to be submitted	
2	Stability	122
2.1	Intact stability	
2.2	Damage stability for ships where the notation SDS has been required	
3	Hull scantlings	122
3.1	Cable tanks	
3.2	Connection of the machinery and equipment with the hull structure	
4	Other structures	123
4.1	Fore part	
5	Hull outfitting	123
5.1	Equipment	

Section 3 Machinery and Systems

1	General	124
1.1	Propulsion and manoeuvrability	
1.2	Documents to be submitted	
2	Arrangements for cable laying, hauling and repair	124
2.1	Typical machinery and equipment of cable laying ships	
2.2	Design of cable handling machinery and equipment	
2.3	Safety	
2.4	Testing of cable handling machinery and equipment	
3	On board trials	125
3.1	Ship trials	
3.2	Equipment trials	

Section 4 Fire Protection

1	Cable tanks	126
1.1	Means for fire fighting	

CHAPTER 7

DIVING SUPPORT VESSELS

Section 1 General

1	General	129
1.1	Application	
1.2	Scope	
2	Diving system	130
2.1	Description	
2.2	Classification of the diving system	
3	References	130
3.1	Acronyms	
3.2	Definitions	
3.3	Reference rules and regulations	
4	Documents to be submitted	132
4.1	General	
4.2	Diving system documentation	

Section 2 General Arrangement

1	General arrangement	134
1.1	Diving system arrangements	
1.2	Machinery spaces	
1.3	Hazardous areas	
1.4	Breathing gas storage	
1.5	Location of deck decompression chamber	
1.6	Diving operations	
2	Access arrangement	134
2.1	General	
2.2	Means of evacuation	

Section 3 Structural Assessment

1	Diving equipment foundations	135
1.1	General	
1.2	Design loads	
1.3	Allowable deflection	
2	Launching system foundations	135
2.1	General	

Section 4 Machinery and Systems

1	Sea inlets	136
1.1	General	

2	Position keeping	136
	2.1 General	
	2.2 Dynamic positioning	
3	Electrical installations	136
	3.1 General	
	3.2 Electrical power supply	
4	Diving control station	137
	4.1 General	
	4.2 Communication and relocation system	
5	Diver heating system	137
	5.1 Oil fired heaters	

Section 5 Safety Features

1	Fire safety	138
	1.1 Personnel protection	
	1.2 Structural fire protection	
	1.3 Detection and alarm	
	1.4 Fire-fighting equipment	
2	Breathing gas system	139
	2.1 Storage on board	
	2.2 Piping	
	2.3 Oxygen installation	
	2.4 Colour code	
	2.5 Signboards	
3	Ventilation	140
	3.1 General	
4	Means of evacuation of the divers in saturation	140
	4.1 Application	
	4.2 Hyperbaric evacuation system	
	4.3 Launching arrangement	

Section 6 Specific Requirements for Ships Assigned with the Service Notation diving support-capable

1	General	141
	1.1 Application	
	1.2 Documents to be submitted	
	1.3 Activation of service notation diving support-portable	
2	General arrangement	142
	2.1 General	
3	Structural assessment	142
	3.1 General	

4	Machinery and systems	142
4.1	Position keeping	
4.2	Sea inlets	
5	Electrical installations and automations	142
5.1	Electrical power supply	
6	Safety features	142
6.1	Fire safety	
6.2	Breathing gas facilities	
6.3	Ventilation	

Section 7 Initial Inspection and Testing

1	General	143
1.1	Application	
1.2	Non-permanent diving system	
2	On-board testing	143
2.1	Diving installations	

CHAPTER 8

LIFTING UNITS

Section 1 General

1	General	147
1.1	Application	
1.2	Scope	
2	Lifting equipment	147
2.1	Certification of the lifting equipment	
3	References	147
3.1	Acronyms	
3.2	Definitions	
4	Documents to be submitted	148
4.1	General	
4.2	Lifting equipment documentation	

Section 2 General Arrangement

1	General	150
1.1	Location of lifting appliances	
1.2	Position of the crane during navigation	

Section 3 Stability and Subdivision

1	General	151
1.1	Application	
1.2	Definitions	
1.3	Loading conditions	
1.4	Trim and stability booklet	
1.5	Model tests or direct calculations	
1.6	Operational procedures against capsizing	
1.7	Guidance on wind force	
2	Intact stability	153
2.1	General stability criteria	
2.2	Lifting operations conducted under environmental and operational limitations	
2.3	Intact stability criteria in the event of sudden loss of the lifted load	
3	Intact stability - alternative method	155
3.1	General	
3.2	Alternative stability criteria	
4	Additional intact stability criteria for crane overload test	156
4.1	General	

5	Alternative damage stability for lifting operations for ships where additional class notation SDS is assigned	156
5.1	Application	
5.2	Data to be submitted	
5.3	Extent of damage	
5.4	Alternative damage stability criteria	

Section 4 Structural Assessment

1	General	157
1.1	Application	
2	Hull girder strength	157
2.1	Principles	
2.2	Hull framing	
2.3	Hull girder loads	
3	Structural design principles	157
3.1	General	
3.2	Crane pedestal	
3.3	Mobile lifting equipment	
3.4	Devices for equipment stowage	
3.5	Connecting bolts	
4	Materials and welding	158
4.1	Structural category and steel grades for the foundations of the lifting equipment	
4.2	Welding	
5	Design loads	158
5.1	General	
5.2	Lifting loads	
5.3	Environmental loads	
5.4	Hull girder stress	
6	Loading conditions	159
6.1	General	
6.2	Load cases	
7	Allowable stress	159
7.1	General	
7.2	Criteria	
7.3	Basic allowable stress factor	
7.4	Material strength	
7.5	Equivalent stress	
8	Buckling	160
8.1	General	
8.2	Buckling strength criteria	
9	Fatigue	161
9.1	General	

Section 5 Machinery and Systems

1	General	162
1.1	Essential service	
1.2	Hazardous areas	
2	Position keeping	162
2.1	General	
2.2	Dynamic positioning	
3	Power supply	162
3.1	General	
4	Lifting equipment controls	162
4.1	General	
4.2	Overload prevention	
4.3	Emergency system	
4.4	Communication means	

Section 6 Initial Inspection and Testing

1	General	163
1.1	Application	
2	Onboard testing	163
2.1	Lifting installations	

Section 7 Self-Elevating Ships

1	General	164
1.1	Application	
1.2	Applicable rules and regulations	
2	Classification principles	164
2.1	Classification limits	
2.2	Design criteria statement	
3	Definitions	165
3.1	Self-elevating ship	
3.2	Modes of operation	
3.3	Water levels, crest elevation and water depth	
3.4	Configuration of a self-elevating unit in elevated position	
4	Documents to be submitted	166
4.1	General	
4.2	Operating manual	
5	Structure design principles	167
5.1	General	

6	Design conditions	167
6.1	General	
6.2	Design conditions in elevated configuration	
6.3	Transit conditions	
6.4	Installation conditions	
7	Structural analysis	167
7.1	Structural analysis in elevated position	
7.2	Structural analysis in transit conditions and installations conditions	
8	Jacking system	168
8.1	General	
8.2	Electricity and automation	
9	Fire and safety	168
9.1	Firefighting water supply	
10	Construction survey	168
10.1	Self-elevating system	

CHAPTER 9

SEMI-SUBMERSIBLE CARGO SHIPS

Section 1 General

1	General	171
1.1	Application	
1.2	Scope	
1.3	Definitions	
2	Documents to be submitted	172
2.1	General	
2.2	Submersion operating manual	

Section 2 General Arrangement

1	General	174
1.1	Draft marks	
2	Ballast system arrangement	174
2.1	General	
2.2	Central ballast control station	

Section 3 Stability, Subdivision and Load Line

1	General	175
1.1	Additional class notation SDS	
1.2	Loading instrument	
1.3	Stability verification in temporary submerged conditions	
1.4	Submersion procedure	
2	Loading conditions	175
2.1	Transit conditions	
2.2	Temporary submerged conditions	
3	Intact stability in transit conditions	175
3.1	General	
3.2	Buoyancy of the cargo	
4	Damage stability in transit conditions	176
4.1	General	
4.2	Buoyancy of the cargo	
4.3	Type B freeboard	
4.4	Type B-60 and B-100 freeboard	
5	Intact stability in temporary submerged conditions	177
5.1	Criteria	

6	Damage stability in temporary submerged conditions	177
	6.1 General	
	6.2 Extent of damage	
	6.3 Compartment permeability	
	6.4 Damage criteria	
	6.5 Intermediate stage of flooding	
7	Temporary submersion	178
	7.1 International Load Line Certificate	
	7.2 Reserve buoyancy	
	7.3 Watertight openings	
	7.4 Openings	

Section 4 Hull Structure

1	General	179
	1.1 Application	
	1.2 Internal ballast pressure when using overflow tanks	
2	Loading conditions	179
	2.1 General	
3	Design loads	179
	3.1 Vertical wave bending moments	
	3.2 Horizontal wave bending moments	
	3.3 Ship motions and accelerations	
	3.4 Vertical wave shear forces	
	3.5 Still water and inertial pressures	
4	Hull girder strength	180
	4.1 General	
5	Hull scantlings	180
	5.1 General	
	5.2 Structural models	
6	Connection of the buoyancy casings	180
	6.1 General	
	6.2 Design loads	
	6.3 Strength criteria	
7	Fatigue strength assessment	180
	7.1 General	

Section 5 Machinery and Systems

1	General	181
	1.1 Sea pressure	
2	Ballast system	181
	2.1 Failure modes and effects analysis	
	2.2 Failure modes	
	2.3 Definitions	

2.4	Safety principles	
2.5	Air pipes	
2.6	Overflow tanks	
2.7	Valves and actuators	
2.8	Pressurized ballast tanks	
2.9	Control and monitoring	
3	Scuppers and sanitary discharges	182
3.1	Arrangement of scuppers and sanitary discharges	

Section 6 Electrical Installations and Controls

1	Emergency source of power	183
1.1	Essential service	
2	Controls	183
2.1	Draft mark automatic gauges	
2.2	Ballast tanks gauging system	
2.3	Ballast valves monitoring	
2.4	Communication means	

Section 7 Safety Features

1	Fire safety	184
1.1	General	
1.2	Fire hydrants	
2	Means of escape	184
2.1	Transit conditions	
2.2	Temporary submerged conditions	
3	Life-saving appliances	184
3.1	Temporary submerged conditions	

Section 8 Initial Inspection and Testing

1	General	185
1.1	Application	
2	Commissioning	185
2.1	At quay	
2.2	Sea trials	

CHAPTER 10

STANDBY RESCUE VESSELS

Section 1 General

1	General	189
1.1	Application	
1.2	Documents to be submitted	

Section 2 Rescue Arrangement, Accommodation and Equipment

1	General	191
1.1	Wheelhouse	
2	Rescue equipment and facilities	191
2.1	Rescue zone	
2.2	Scrambling net	
2.3	Retrieval device	
2.4	Rescue hooks	
2.5	Fast Rescue Craft (FRC)	
2.6	Safety equipment	
2.7	Helicopter winching area	
3	Survivors spaces	192
3.1	General	
3.2	Decontamination area	
3.3	Reception area	
3.4	Treatment room	
3.5	Accommodations	
3.6	Non-survivors	
4	Medical equipment and supplies	192
4.1	Water	
4.2	Meals	
4.3	Sundries	
4.4	Medical equipment	

Section 3 Hull and Stability

1	Stability	193
1.1	General	
1.2	Additional requirements for towing operations	
1.3	Additional requirements for water spraying	
2	Hull	193
2.1	Vessels intended for towing operations	
2.2	Lifeboat towing	

Section 4 Machinery

1	General	194
1.1	Application	
1.2	Ship propulsion and manoeuvrability	
1.3	Exhaust pipes	

Section 5 Electrical Installations

1	General	195
1.1	Electrical installations	
1.2	Searchlight	

Section 6 Fire Protection

1	General	196
1.1	Additional requirements for water spraying	

CHAPTER 11

ACCOMMODATION UNITS

Section 1 General

1	General	199
1.1	Application	
1.2	Applicable rules	
1.3	Definitions	
2	Documents to be submitted	200
2.1	General	

Section 2 Electrical Installations and Automation

1	Interaction with operational ships or units	201
1.1	Application	
1.2	Emergency Shutdown	

Section 3 Fire Protection, Detection and Extinction

1	Interaction with operational ships or units	202
1.1	Application	
1.2	Structural integrity	
1.3	Installation layout	

Section 4 Specific Requirements for Ships Assigned with the Additional Service Feature SPxxx-capable

1	General	203
1.1	Application	
1.2	Documents to be submitted	
2	Design review	203
2.1	Specific requirements	
2.2	Stability assessment	
2.3	Safe Return to Port	

CHAPTER 12

PIPE LAYING UNITS

Section 1 General

1	General	207
1.1	Application	
1.2	Scope	
2	Pipe laying system	207
2.1	General	
2.2	Certification of the pipe laying equipment	
3	Documents to be submitted	208
3.1	General	
3.2	Pipe laying equipment documentation	

Section 2 Stability and Subdivision

1	General	209
1.1	Application	
1.2	Loading conditions	

Section 3 Structural assessment

1	General	210
1.1	Application	
2	Hull girder strength	210
2.1	Principles	
3	Materials and welding	210
3.1	Structural category and steel grades for the foundations of the pipe laying equipment	
4	Pipe laying equipment foundations	210
4.1	General	
4.2	Connecting bolts	

Section 4 Initial Inspection and Testing

1	General	211
1.1	Application	
2	Onboard testing	211
2.1	Pipe laying installations	

Part E
**Service Notations for
Offshore Service Vessels and Tugs**

Chapter 1
TUGS

- SECTION 1 GENERAL**
- SECTION 2 STABILITY**
- SECTION 3 HULL STRUCTURE**
- SECTION 4 INTEGRATED TUG/BARGE COMBINATION**
- SECTION 5 TESTING**

SECTION 1 GENERAL

1 General

1.1 Application

1.1.1 Ships complying with the requirements of this Chapter are eligible for the assignment of one of the following service notations:

- tug
- salvage tug
- escort tug

as defined in Pt A, Ch 1, Sec 2, [4.7].

These service notations are always completed by the additional service feature **design bollard pull** = $[T_{BP} / 9,81]$ t, where the design Bollard Pull T_{BP} is defined in [2.1].

The service notation **escort tug** is always completed by the following additional service features:

- **design maximum braking force** = $[T_{X,MAX} / 9,81]$ t
- **design maximum escort speed** = $[V_{MAX}]$ kN
- **design maximum steering force** = $[T_{Y,MAX} / 9,81]$ t

where the design maximum values are defined in [2.7].

Ships which are likely to operate at sea within specific limits may, under certain conditions, be granted an operating area notation. For the definition of operating area notation, reference is made to Pt A, Ch 1, Sec 2, [5.3].

1.1.2 Ships dealt with in this Chapter are to comply with:

- Part A of the Rules
- NR216 Materials and Welding

- applicable requirements according to Tab 1 and specific requirements for testing as detailed in Ch 1, Sec 5
- Ch 1, Sec 4 for tugs assigned with the additional service feature **barge combined**.

2 Definitions

2.1 Design bollard pull

2.1.1 The design bollard pull T_{BP} , in kN, is the maximum sustained towline force the tug is capable of generating at zero forward speed, to be initially specified by the Designer and to be verified by a full scale test, generally referred to as bollard pull test (see Ch 1, Sec 5, [2.1.1]).

2.1.2 Where the value of the design bollard pull is not provided, the following default values may be used for preliminary design review:

- $T_{BP} = 0,204 N P_S$
for conventional tugs with propellers fitted with nozzles, as described in Ch 1, Sec 3, [2.1.2]
- $T_{BP} = 0,176 N P_S$
for tractor tugs and ASD tugs with steerable propellers fitted with nozzles, as described in Ch 1, Sec 3, [2.1.3] and Ch 1, Sec 3, [2.1.4] respectively.

where:

- N : Number of propellers
- P_S : Maximum continuous power per propeller shaft, in kW.

Table 1 : Applicable requirements

Item		Greater than or equal to 500 GT	Less than 500 GT
Ship arrangement	$L \geq 90$ m	• Part B	• NR566
	$L < 90$ m	• NR600	• NR566
Hull	$L \geq 90$ m	• Part B • Ch 1, Sec 3	• Part B • Ch 1, Sec 3
	$L < 90$ m	• NR600 • Ch 1, Sec 3	• NR600 • Ch 1, Sec 3
Stability		• Part B • Ch 1, Sec 2	• NR566 • Ch 1, Sec 2
Machinery and cargo systems		• Part C	• NR566
Electrical installations		• Part C	• NR566
Automation		• Part C	• NR566
Fire protection, detection and extinction		• Part C	• NR566 • Article [3]
<p>Note 1: NR566: Hull Arrangement, Stability and Systems for Ships less than 500 GT NR600: Hull Structure and Arrangement for the Classification of Cargo Ships less than 65 m and Non Cargo Ships less than 90 m.</p>			

Figure 1 : Schematic overview of indirect towing modes (escort tug)

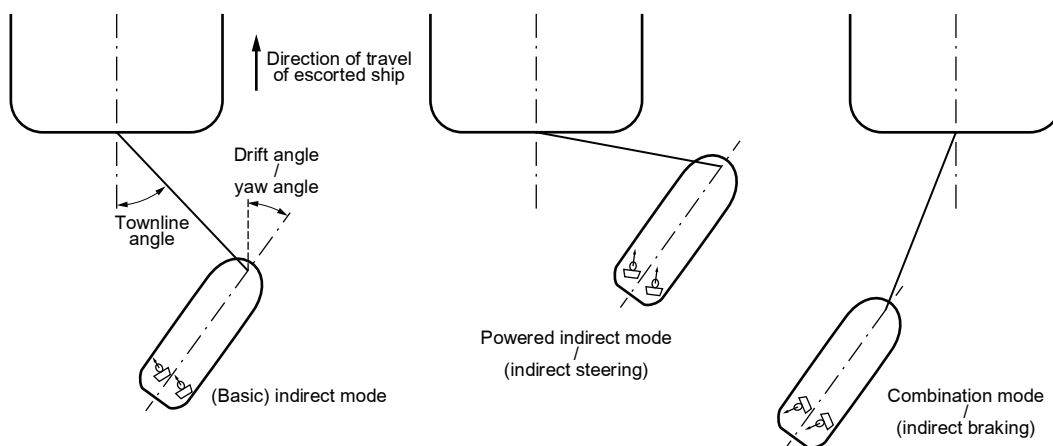

2.2 Reference towline force

2.2.1 The reference (quasi-static) towline force T , in kN, is considered to represent:

- the design bollard pull T_{BP} for service notations **tug** and **salvage tug**, see [2.1]
- the design maximum steady towline force $T_{ESC,MAX}$ for service notation **escort tug**, see [2.7].

2.3 Design load

2.3.1 The design load DL , in kN, is the force taken into consideration for the strength assessment and testing of the towing equipment and the associated supporting structures, and is to be taken as not less than:

$$DL = DAF T_{BP}$$

where:

DAF : Dynamic amplification factor taking into consideration dynamic effects.

Reference values for the DAF are given in:

- for service notations **tug** and **salvage tug**:
Ch 1, Sec 3, [2.7.2]
- for service notation **escort tug**:
Ch 1, Sec 3, [3.2.2].

2.4 Winch brake holding load

2.4.1 The winch brake holding load BHL , in kN, is the maximum towline force the towing winch can withstand without slipping of the (activated) brake, considering the towline at the first inner layer.

2.4.2 The BHL is a reference for the strength assessment and testing of towing winches and associated towing fittings (e.g. fairlead, staple, gob-eye) as well as their supporting structures.

2.5 Towline breaking strength

2.5.1 The towline breaking strength, in kN, is the tension required to cause failure of the towline (parting of the towline).

2.6 Escort tugs indirect towing modes

2.6.1 General

Escorting is considered to include active (emergency) steering, braking and otherwise controlling of the escorted ship by the tug operating in indirect towing mode, whereby the ahead speed of the escorted ship is within a typical speed range of 6 to 10 knots.

Escort tugs may work in different indirect towing modes, depending on the required action towards the escorted ship (e.g. steering, braking). The main indirect towing modes relevant for escort tugs are schematically shown in Fig 1.

Where reference is made to “indirect steering” the objective is to maximise the steering force in indirect towing mode.

Where reference is made to “indirect braking” the objective is to maximise the braking force in indirect towing mode.

2.6.2 Indirect towing principle

In indirect towing mode, the towline force is resulting from the (quasi-static) equilibrium condition reached between the forces and moments arising from the hydrodynamic lift and drag forces acting on the hull and appendices of the tug advancing through the water at a drift angle relative to the water flow, the thrust vector and the towline force.

Note 1: In direct towing mode the thrust is directly applied to generate the towline force, whereby hydrodynamic lift and drag forces play no significant role.

2.6.3 Various indirect towing modes

- In (basic) indirect mode the towline force is generated primarily by the hydrodynamic forces acting on the hull and skeg, with the thrust used solely to maintain the desired drift angle (also referred to as yaw angle)
- In powered indirect mode (indirect steering) the transverse component of thrust is used to maintain the desired drift angle, while a significant longitudinal component of thrust is applied in forward direction of the tug.

Compared to the (basic) indirect mode, the tug is operating more sideways of the escorted ship with a relatively large towline angle, generating a higher steering force

- c) In combination mode (indirect braking) the same principle as for the indirect steering mode is applied, except that the longitudinal component of thrust is applied in aftward rather than forward direction.

Compared to the (basic) indirect mode, the tug is operating more behind the escorted ship with a relatively small towline angle, generating a higher braking force.

2.6.4 Specific considerations

- a) For indirect towing modes it is recommended to design the tug to generate high (indirect) towline forces with minimal propulsion thrust, while respecting the limits imposed by stability and strength considerations (towing equipment, general hull structure).
- b) The propulsion engines are to ensure sufficient thrust for manoeuvring the tug quickly for any drift angle (refer to angle β as defined in [2.7.2]).
- c) In the case of loss of propulsion, the heeling moment due to the remaining forces is to lead to a safe equilibrium position of the tug with reduced heeling angle.

2.7 Escort forces and speed

2.7.1 The steady towline force during escorting, T_{ESC} , in kN, is the towline force associated with the considered (quasi-static) equilibrium in indirect towing mode, excluding short time-duration dynamic effects, for a given loading condition and escort speed V , see Fig 2. The steady towline force is applied by the tug on the stern of the escorted ship.

2.7.2 The following angles are defined in relation to escort operations (see Fig 2):

- The towline angle α , in deg, is the angle between the towline and the centreline of the escorted ship, and
- The drift angle β , in deg, is the angle between the centreline of the tug and the centreline of the escorted ship (also referred to as yaw angle).

Figure 2 : Typical escort configuration

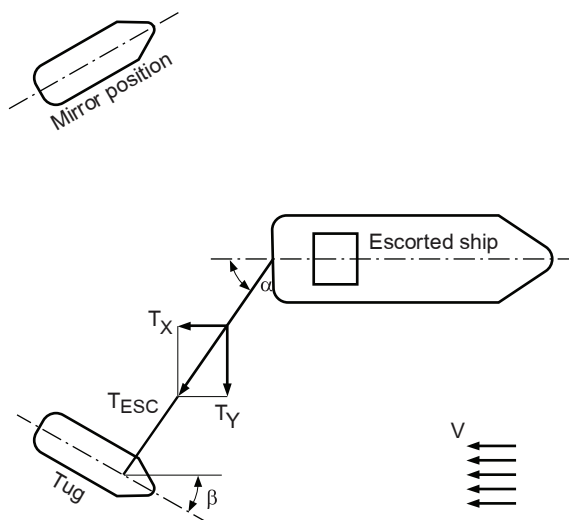

2.7.3 The steady towline force T_{ESC} can be decomposed into a steering force T_Y and a braking force T_X (see Fig 2):

- The steering force T_Y , in kN, is the transverse component of the steady towline force T_{ESC} with respect to the escorted ship
- The braking force T_X , in kN, is the longitudinal component of the steady towline force T_{ESC} with respect to the escorted ship.

2.7.4 The design maximum escort speed V_{MAX} , in kN, is the highest escort speed V for which the escort tug is designed to perform escort operations, to be specified by the Designer and not to be taken higher than 10 knots.

Note 1: For high powered escort tugs with a free running speed of more than 15 knots the Society may, on a case-by-case basis, accept a design maximum escort speed of 12 knots.

2.7.5 The following rated values of the above defined escort forces are to be specified by the designer:

- The rated steady towline force $T_{ESC,R}$, in kN, is the highest anticipated steady towline force T_{ESC} , as obtained from the evaluation of the escort forces for a particular loading condition and escort speed, taking into account the applicable stability and strength criteria
- The rated steering force $T_{Y,R}$, in kN, is the highest anticipated steering force T_Y , as obtained from the evaluation of the escort forces for a particular loading condition and escort speed, taking into account the applicable stability and strength criteria
- The rated maximum braking force $T_{X,R}$, in kN, is the highest anticipated braking force T_X , as obtained from the evaluation of the escort forces for a particular loading condition and escort speed, taking into account the applicable stability and strength criteria.

2.7.6 The following maximum values of the above defined rated escort forces are to be specified by the designer:

- The design maximum steady towline force $T_{ESC,MAX}$, in kN, is the highest rated steady towline force $T_{ESC,R}$ over the applicable range of loading conditions and escort speeds
- The design maximum steering force $T_{Y,MAX}$, in kN, is the highest rated steering force $T_{Y,R}$ over the applicable range of loading conditions and escort speeds
- The design maximum braking force $T_{X,MAX}$, in kN, is the highest rated braking force $T_{X,R}$ over the applicable range of loading conditions and escort speeds.

2.7.7 The matrix of rated steady towline forces $T_{ESC,R}$, steering forces $T_{Y,R}$ and braking forces $T_{X,R}$ is to be initially specified by the Designer and to be verified by the Society on the basis of the results of:

- full scale trials, or
- model testing, or
- a computer simulation program accepted by the Society.

2.7.8 Full scale trials, where applicable, should be performed in accordance with a procedure agreed with the Society prior to commencement of the trials and comply with the requirements of Ch 1, Sec 5, [3.2].

2.7.9 Model testing, where applicable, should be performed in accordance with a procedure agreed with the Society prior to commencement of the tests and comply with the requirements of Ch 1, Sec 5, [3.2]. Special attention is to be paid to scale effects when processing the measurement result to create predictions at full scale.

2.7.10 Computer simulation programs for predicting escort performance are to comply with the requirements of Ch 1, Sec 5, [3.1].

3 Fire safety

3.1 Suppression of fire

3.1.1 Fire pumps

For tugs assigned with the operating area notation **operating within 5 miles from shore**, the portable fire pump required in NR566, Ch 4, Sec 5, [2.2.3] may be omitted.

3.1.2 Fixed fire-extinguishing system

Tugs assigned with the operating area notation **operating within 5 miles from shore** may be considered as ships of less than 12 m operating in **coastal area** or **sheltered area** according to NR566, Ch 4, Sec 5, [4.2].

SECTION 2

STABILITY

1 Application

1.1

1.1.1 The requirements of this Section apply as follows depending on the ship service notation:

- **tug**, mainly intended for towing services, are to comply with the requirements in Article [3]
- **salvage tug**, having specific equipment for salvage services, are to comply with the requirements in Article [3]
- **escort tug**, mainly intended for escort services such as for steering, braking and otherwise controlling escorted ships, are to comply with the requirements in Articles [3] and [4].

In addition, ships with the additional service feature **barge combined** are to comply with the applicable requirements in Ch 1, Sec 4.

2 Openings

2.1 General

2.1.1 Openings which cannot be closed weathertight

Openings in the hull, superstructures or deckhouses which cannot be closed weathertight are to be considered as unprotected openings and, consequently, as down-flooding points for the purpose of stability calculations (the lower edge of such openings is to be taken into account).

2.1.2 Ventilation openings of machinery space and emergency generator room

It is recognised that for tugs, due to their size and arrangement, compliance with the requirements of ICLL Reg. 17(3) for ventilators necessary to continuously supply the machinery space and the emergency generator room may not be practicable. Lesser heights of the coamings of these particular openings may be accepted if the openings:

- are positioned as close to the centreline and as high above the deck as practicable in order to maximise the down-flooding angle and to minimise exposure to green water
- are provided with weathertight closing appliances in combination with suitable arrangements, such as separators fitted with drains
- are equipped with efficient protective louvers and mist eliminators
- have a coaming height of not less than 900 mm above the deck
- are considered as unprotected openings and, consequently, as down-flooding points for the purpose of stability calculations.

3 General requirements

3.1 Intact stability

3.1.1 The stability of the ship for the loading conditions in Pt B, Ch 3, App 2, [1.2.11] is to be in compliance with the requirements in Pt B, Ch 3, Sec 2.

3.1.2 Additional intact stability criteria

All the loading conditions reported in the trim and stability booklet which are intended for towing operations are also to be checked in order to investigate the ship's capability to withstand the effect of the transverse heeling moments induced by the combined action of the towline force and the thrust vector (self-tripping, see [3.1.3]), and induced by the hydrodynamic resistance of the hull (tow-tripping, see [3.1.4]).

Figure 1 : Heeling and righting arms curves

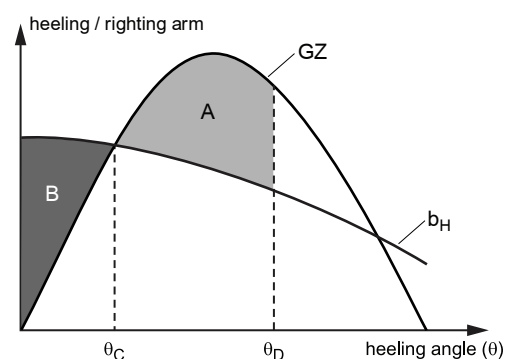

3.1.3 Self-tripping

A tug may be considered as having sufficient stability to withstand the self-tripping heeling moment if the following condition is complied with (see Fig 1):

$$A \geq B$$

where:

- A : Area, in m.rad, contained between the righting arm and the heeling arm curves, measured from the heeling angle θ_C to the heeling angle θ_D
- B : Area, in m.rad, contained between the heeling arm and the righting arm curves, measured from zero heel ($\theta = 0$) to the heeling angle θ_C
- θ_C : Heeling angle of equilibrium, corresponding to the first intersection between heeling and righting arms curves
- θ_D : Heeling angle, to be taken as the lesser of:
 - heeling angle corresponding to the second intersection between heeling and righting arm curves
 - the angle of downflooding.

The self-tripping heeling arm curve is to be calculated as follows:

$$b_H = \Sigma b_{Hi}$$

where:

b_{Hi} : Heeling arm induced by one thruster or group of thrusters i , in m, calculated as follows:

$$b_{Hi} = \frac{T_{BPI} C_i (h_i \cos \theta - r \sin \theta)}{9,81 \Delta}$$

T_{BPI} : Amount of thrust, in kN, generated by one thruster or group of thrusters i . The sum of all the individual thrusts is to be equal to the design Bollard Pull, as defined in Ch 1, Sec 1, [2.1].

h_i : Vertical distance, in m, between the towing point (fairlead, staple, towing hook or equivalent fitting) and the horizontal centreline of the propulsion unit or group of units i , as relevant for the considered towing situation

r : Transverse offset, in m, between the towing point and the ship's centerline.

The towing point is the location where the tow-line force is applied to the ship (fairlead, staple, towing hook or equivalent fitting).

When the towing point is not at the center line, the most unfavourable tow line position is to be considered.

C_i : Coefficient to be taken equal to:

- $c = 0,90 / (1 + d_i / L_{LL})$ for a group of 2 azimuthing thrusters, but is in no case to be taken less than:
 - 0,70 for ASD tugs towing over the stern and tractor tugs towing over the bow
 - 0,50 for ASD tugs towing over the bow and tractor tugs towing over the stern, respectively
- $c = 1 / (1 + d_i / L_{LL})$ for a single azimuthing thruster
- $c = 0,50$ for non-azimuth propulsion unit or group of units

Δ : Loading condition displacement, in tons

θ : Angle of heel, in degrees

d_i : Longitudinal distance, in m, between the towing point (fairlead, staple, towing hook or equivalent fitting) and the vertical centreline of the propulsion unit or group of units i , as relevant for the considered towing situation

L_{LL} : Load line length, in m, defined in Pt B, Ch 1, Sec 2, [3.2].

3.1.4 Tow-tripping

A tug may be considered as having sufficient stability to withstand the tow-tripping heeling moment if the first intersection between the righting arm curve and the tow-tripping heeling arm curve for tow-tripping occurs at an angle of heel less than the angle of downflooding.

The tow-tripping heeling arm curve is to be calculated as follows:

$$b_H = \frac{C_1 C_2 \gamma V^2 A_p (h \cos \theta - r \sin \theta + C_3 T)}{19,62 \Delta}$$

where:

C_1 : Lateral traction coefficient, taken equal to:

$$C_1 = 2,8 \left(\frac{L_s}{L_{LL}} - 0,1 \right)$$

without being taken lower than 0,1 and greater than 1

L_s : Longitudinal distance, in m, from the aft end of L_{LL} to the towing point

C_2 : Angle of heel correction for C_1 , taken equal to:

$$C_2 = \left(\frac{\theta}{3\theta_d} + 0,5 \right)$$

without being taken lower than 1

θ_d : Angle to deck edge, in deg, taken equal to:

$$\theta_d = \text{atan} \left(\frac{2f}{B} \right)$$

f : Freeboard amidships, in m

γ : Specific water density, in t/m^3 , to be taken equal to 1,025

V : Lateral velocity, in m/s, to be taken equal to 2,57 (5 knots)

A_p : Lateral projected area, in m^2 , of the underwater hull

C_3 : Distance from the center of A_p to the waterline as a fraction of the draught related to the heeling angle, taken equal to:

$$C_3 = \left(\frac{\theta}{\theta_d} \right) 0,26 + 0,3$$

without being taken lower than 0,5 and greater than 0,83

T : Loading condition draught, in m

h : Vertical distance, in m, from the waterline to the towing point.

4 Additional requirements for escort tugs

4.1 Intact stability

4.1.1 All the loading conditions reported in the trim and stability booklet which are intended for escorting operations are also to be checked in order to investigate the tug's capability to withstand the effect of the transverse heeling moment induced by the combined action of the following forces:

- hydrodynamic forces acting on the hull and appendices
- thrust forces
- steady towline force.

4.1.2 The stability calculations are to be performed on the basis of the highest anticipated heeling moment for the considered loading condition, which is to be obtained from the results of full scale tests, model tests, or, alternatively, the results of a computer simulation program accepted by the Society (refer to Ch 1, Sec 5, [3.1]).

4.1.3 For each relevant loading condition the evaluation of the highest anticipated heeling moment is to be performed for the applicable range of speeds and towline angles, as defined in the escort towing arrangement plan. As a minimum, the conditions corresponding to the design maximum steering force $T_{Y,MAX}$, and design maximum braking force $T_{X,MAX}$, as defined in Ch 1, Sec 1, [2.7], are to be included in the evaluation.

4.1.4 The highest anticipated heeling moment is to be assumed constant for the purpose of the stability calculations.

4.1.5 The value of the highest anticipated heeling moment is to be specified by the Designer in the stability calculations. In addition, an arrangement drawing with the location of the towing points and propulsion units is to be included in the stability booklet. In this drawing the longitudinal and vertical distance, in m, from the towing point to the relevant centrelines of the propulsion units and the baseline, respectively, are to be specified.

4.1.6 Preliminary stability calculations on the basis of estimated highest heeling moment and associated heeling arm values may be submitted for (preliminary) examination. If after verification of the heeling arm values on the basis of the results of escort performance trials, model tests or a computer simulation program accepted by the Society (refer to Ch 1, Sec 5, [3.1]) the final values exceed the estimated values, the stability calculations have to be updated for the final heeling moment and heeling arm values. It is recommended to include a reasonable margin in the estimated values (on the basis of design experience).

4.1.7 Criteria

An escort tug may be considered as having sufficient stability to withstand the heeling moment arising from the towline, if the three following conditions are complied with:

$$A \geq 1,25 B$$

$$C \geq 1,40 D$$

$$\theta_C \leq 15^\circ$$

where:

- A : Righting arm curve area, in m-rad, measured from the heeling angle θ_C to a heeling angle of 20° (see Fig 2)
- B : Heeling arm curve area, in m-rad, measured from the heeling angle θ_C to a heeling angle of 20° (see Fig 2)
- C : Righting arm curve area, in m-rad, measured from zero heel ($\theta = 0$) to the heeling angle θ_D (see Fig 3)

D : Heeling arm curve area, in m-rad, measured from zero heel ($\theta = 0$) to the heeling angle θ_D (see Fig 3)

θ_C : Heeling angle of equilibrium, corresponding to the first intersection between heeling arm and righting arm curves, to be obtained when the highest anticipated heeling moment resulting from the steady towline force T_{ESC} as defined in Ch 1, Sec 1, Fig 2, is applied to the escort tug

θ_D : Heeling angle, to be taken as the lesser of:

- the angle of downflooding
- 40°
- the heeling angle corresponding to the second intersection between heeling and righting arms heeling and righting arm curves.

4.1.8 Operating information for service notation escort tug

Additional operating information is to be provided in the stability booklet in relation to the design limitations related to the assignment of the service notation **escort tug**.

As a minimum, the following information is to be included:

- Design operating area and environmental conditions for performing escort operations (refer to Pt A, Ch 1, Sec 2, [4.7])
- The maximum escort speed V_{MAX} (refer to Ch 1, Sec 1, [2.7])
- A table with permissible values of heeling angle and steady towline force as function of loading condition and escort speed (based on the rated steering and braking forces as obtained from Ch 1, Sec 5, [3.1] or Ch 1, Sec 5, [3.2], as applicable)
- Instructions to the master regarding the handling of the escort tug and the associated towing equipment, demonstrating the implementation of effective means to limit the steady towline force and heeling angle within the permissible limits and the use of the emergency release system.

Note 1: Adjustable audible or visible alarms, providing a warning to the master when the heeling angle and/or steady towline force exceeds the permissible value(s) applicable to the relevant loading condition and escort speed, in combination with appropriate handling instructions are as effective means.

The table with permissible values of heeling angle and steady towline force as function of loading condition and escort speed is to be displayed in the wheelhouse next to the control desk or another appropriate location.

4.2 Inclinator

4.2.1 Escort tugs are to be equipped with a calibrated heeling angle measurement system (inclinator).

The measured heeling angle is to be displayed in the wheelhouse next to the control desk or another appropriate location.

Figure 2 : Definition of the areas A and B

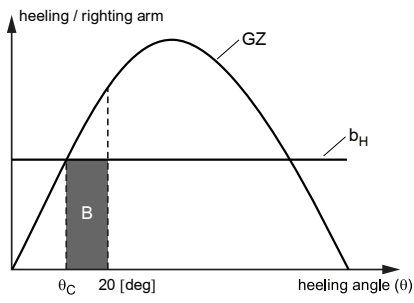
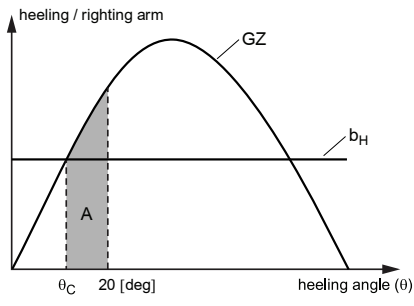
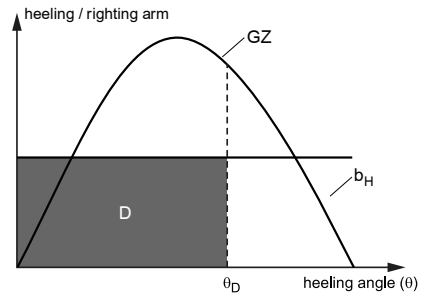
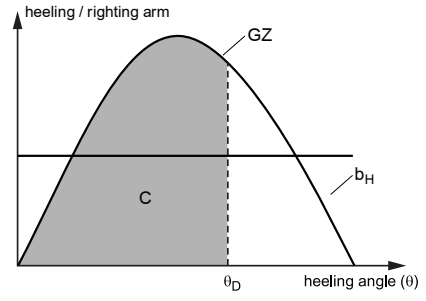

Figure 3 : Definition of the areas C and D



SECTION 3

HULL STRUCTURE

1 General

1.1 Application

1.1.1 The requirements of this Section apply as follows depending on the ship service notation:

- **tug**, mainly intended for towing services, are to comply with the requirements in Article [2]
- **salvage tug**, having specific equipment for salvage services, are to comply with the requirements in Articles [2] and [4]
- **escort tug**, mainly intended for escort services such as for steering, braking and otherwise controlling escorted ships, are to comply with the requirements in Articles [2] and [3].

In addition, ships with the additional service feature **barge combined** are to comply with the applicable requirements in Ch 1, Sec 4.

1.2 Documents to be submitted

1.2.1 In addition to the documentation requested in Part B, the following documents are to be submitted for approval:

- Description of the connection between the towing system (winch and hook) and the hull structure with indication of the design loads.

2 General requirements

2.1 Typical design arrangements

2.1.1 General

In general, tugs are completely decked ships provided with an ample drift surface and, where intended for service outside sheltered areas, with a forecastle or half forecastle, or at least with a large sheer forward.

2.1.2 Conventional tugs

Conventional tugs have fixed single or multiple shaft arrangement. The propeller(s) can be of fixed pitch or controllable pitch type, normally fitted with Kort nozzle(s). Steering is done by means of rudder(s) or steerable nozzle(s). The towing point is normally located slightly aft of the centre of lateral resistance for towing over the stern with a towing hook and/or towing winch.

Conventional tugs may also be equipped to perform pushing operations.

2.1.3 Tractor tugs

Tractor tugs are fitted with omnidirectional thrusters (typically two steerable propellers or Voith-Schneider type cycloidal propulsion units), which are located forward of the towing point (usually not more than 30% of the length from the forward end). A skeg or vertical fin is fitted aft. Towing is performed over the stern with a towing winch and/or towing hook.

Tractor tugs may also be equipped to perform pushing operations.

2.1.4 Azimuth stern drive tugs (ASD tugs)

Azimuth stern drive (ASD) tugs are fitted with multiple steerable propellers located near the aft end. Typically, ASD tugs can perform towing operations over the bow with the forward towing winch (towing operation similar to a tractor tug) and over the stern with a towing hook and/or second towing winch (towing operation similar to a conventional tug). In both cases the towing point is located forward of the thrusters. ASD tugs may be fitted with a skeg, the size and location depending on the intended function.

ASD tugs may also be equipped to perform pushing operations.

2.1.5 Other design arrangements

Other tug design arrangements, having towing and propulsion configurations different from the design arrangements described in [2.1.1] to [2.1.4], have been developed and built, and are to be considered by the Society on a case-by-case basis.

For tugs with combined aft and fore thrusters, every thruster having the same longitudinal location is to be considered as belonging to the same group of thrusters.

2.2 Structure design principles

2.2.1 Bollards

For tugs equipped for side towing, the relevant bollards are to be effectively fixed on the deck in way of side transverses and deck beams or bulkheads.

2.2.2 Fenders

A strong fender for the protection of the tug's sides is to be fitted at deck level.

Alternatively, loose side fenders may be fitted, provided that they are supported by vertical ordinary stiffeners extending from the lightship waterline to the fenders themselves.

2.2.3 Floors

Floors are to be arranged with a welded face plate in the machinery space; elsewhere, floor flanging may be accepted as an alternative to the fitting of welded face plates.

2.2.4 Shaft tunnels

For tugs having small depth, the shaft tunnel may be omitted. In this case, access to the shaft line is to be given through the floor of the space above.

2.3 Hull scantlings

2.3.1 General

The net scantlings of plating, ordinary stiffeners and primary supporting members are to be in accordance with the applicable requirements defined in Ch 1, Sec 1, considering a moulded draught T not less than $0,85 D$ for the calculation of hull girder loads and local loads.

2.4 Other structures

2.4.1 Machinery casings

Exposed machinery casings are to be not less than 900 mm in height, measured from the upper surface of the deck, and provided with weathertight means of closure.

In general, the longitudinal sides of the machinery casings are to be extended downwards by a deck girder to which the deck beams are to be connected.

Side ordinary stiffeners are to be connected to the deck. Their spacing is to be not greater than 0,75 m.

2.4.2 Emergency exits from machinery space

Emergency exits from the machinery space to the upper deck are to be located as high as possible above the waterline and in way of the ship's centreline, so that they may be used even at extreme angles of heel.

Escape hatch coaming heights are to be not less than 600 mm above the upper surface of the deck.

Escape hatch covers are to have hinges fitted such that the predominant direction of green sea will cause the cover to close and are to be capable of being opened and closed weathertight from either side.

2.4.3 Height of hatchway coamings

The height of the hatchway coamings is to be not less than 300 mm. Hatch covers are to be fitted with efficient securing devices.

2.5 Rudder and bulwarks

2.5.1 Rudder

For tugs, the rudder stock diameter is to be increased by 5% with respect to that calculated according to the applicable requirement.

2.5.2 Bulwarks

The bulwarks are to be sloped inboard to avoid distortions likely to occur during contact. Their height may be reduced where required by operational necessities.

2.6 Anchoring and mooring equipment

2.6.1 Wire ropes

Wire ropes may be used as an alternative to chain cables as follows:

- a) Where $L \leq 40$ m, chain cables may be replaced by wire ropes of equal minimum breaking strength, which are to have:
 - a length 1,5 times the required chain cable length, and
 - a short length of chain cable between the wire rope and the anchor, having a length equal to 12,5 m or the distance from the anchor in the stowed position to the winch, whichever is the lesser.
- b) Where $40 \text{ m} < L \leq 90$ m, both chain cables may be replaced by wire rope of equal minimum breaking strength which are to have:
 - a length 1,5 times the required chain cable length, and
 - a minimum mass per unit length of 30% of the required Grade 2 chain cable, and
 - a short length of chain cable between the wire rope and the anchor, having a length equal to 12,5 m or the distance from the anchor in the stowed position to the winch, whichever is the lesser.

2.6.2 Number of anchors

The number of anchors depends on the service notation and optional operating area notation, the propulsion arrangement and the application of a fixed fire-fighting installation. In general, the recommended number of anchors and chain cables is shown in Tab 1.

A reduction of the number of anchors and chain cables may be accepted as depicted in Tab 1 if the following conditions, based on redundancy principles, are complied with:

- the tug is equipped with at least twin propulsion, of which each main engine can maintain sufficient propulsion power to safely return to berth. For this purpose, the main engines should be able to run self-supporting, i.e. independent of generator sets intended for auxiliary power, unless these are able to run parallel and, in case of black-out, have automatic starting and connecting to switchboard within 45 seconds
- a single failure, except fire, is not to cause total propulsion failure
- a fixed fire fighting installation is provided.

It may be considered by the tug builder and operator to apply a spare anchor as an alternative to a second bower anchor. In such case special provisions, such as a crane and suitable storage space for the spare anchor, are to be present on board and the weight and dimensions of the anchor are to be such that it can be handled swiftly. For tugs with the operating area notation **operating ≤ 4 h from a place of refuge**, effectively operating in a fixed and limited area, the spare anchor may be stored ashore.

Table 1 : Number of anchors and chain cables

Service notation	Operating area notation	Number of anchor and chain cables	
		General	Reduced based on redundancy principles (1)
tug	operating within 5 miles from shore	1	0
tug	operating ≤ 4 h from a place of refuge	2	1
tug	–	2	2
salvage tug	–	2	2
escort tug	operating ≤ 4 h from a place of refuge	2	1
escort tug	–	2	2

(1) As detailed in [2.6.2].

Table 2 : Design loads for equipments used for towing operations and supporting structures

Service notation	Operating area notation	T_{BP} , in kN	DL, in kN
tug	operating within 5 miles from shore	$T_{BP} \leq 200$	$2 T_{BP}$
		$200 < T_{BP} < 800$	$[(2600 - T_{BP}) / 1200] T_{BP}$
		$T_{BP} \geq 800$	$1,5 T_{BP}$
tug / salvage tug / escort tug	–	$T_{BP} \leq 400$	$2,5 T_{BP}$
		$400 < T_{BP} < 1000$	$[(3400 - T_{BP}) / 1200] T_{BP}$
		$T_{BP} \geq 1000$	$2 T_{BP}$

Note 1: The DL takes into consideration dynamic effects through the application of the dynamic amplification factor (DAF) (see also Ch 1, Sec 1, [2.3]).

2.7 Towing equipment

2.7.1 General

Towing winches, towing hooks and towline guiding fittings (fairleads, staples, gob-eyes, towing pins, etc.) are normally to be arranged in way of the tug's centerline, in such a position as to minimise heeling moment exerted by the towline force. Effective means are to be provided to lead and restrain the towline within the designed limits of its sweep.

Materials used in towing equipment are to comply with the applicable class requirements for materials. Class certificates are required for the materials used for winch drums, drum shafts, winch brake components, winch supporting frames, towing hooks and towline guiding fittings.

2.7.2 Design load

The design load DL to be considered for the strength assessment of the towing equipment and the associated supporting structures is given in Tab 2.

2.7.3 Towing winches

- a) The winch brake shall normally act directly on the drum and shall be operable in case of failure of the primary power supply system (either manually or otherwise arranged).
- b) The towline attachment to the winch drum is to be provided by means of a weak link or equivalent arrangement that is designed to release the towline at low load.
- c) Towing winches are to be provided with an emergency release system as described in [2.7.4].
- d) Means are to be provided to prevent the fleet angle as shown on Fig 1 from becoming great enough to inhibit operation of the emergency release system.
- e) The dimensioning of the winch drum is to take into account the rope bending specifications provided by the towline manufacturer.
- f) Due consideration is to be given to the proper spooling of the towline on the winch drum, as well as preventing the towline to slip over the flanges of the drum.
- g) Towing winches (in particular the components which are exposed to the tension in the towline, such as the winch drums, drum shafts, brakes, support frame and connection to the hull structure) shall be able to:
 - sustain the DL, as specified in [2.7.2] without permanent deformation, and
 - sustain the BHL, as defined Ch 1, Sec 1, [2.4], without exceeding an equivalent stress level (based on Von Mises criterion) of $0,80 R_{eH}$.
 - sustain the loads for the rated pull condition, as foreseen by the Designer, without exceeding an equivalent stress level (based on Von Mises criterion) of $0,40 R_{eH}$.

Figure 1 : Fleet angle

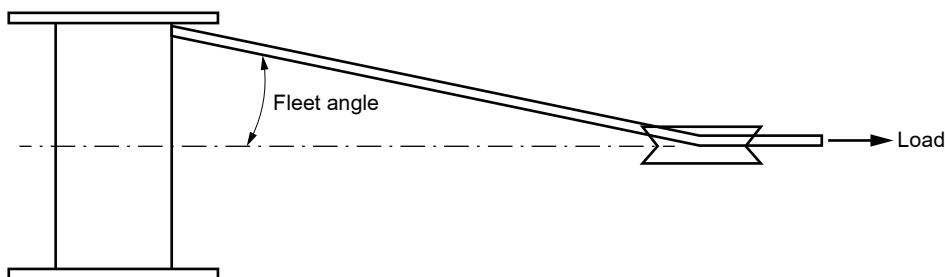

where:

R_{eH} : Minimum specified yield stress of material, in N/mm^2

rated pull: Winch maximum hauling in load at the first inner layer.

- h) Where deemed necessary by the Society, buckling and/or fatigue analysis, performed in accordance with a standard or code of practice recognised by the Society, may be required to be submitted for information.
- i) Towing winches may be equipped with an active pay-out and haul-in system for automatic adjustment of towline. In that case the relevant requirements of [3.2.3] and Ch 1, Sec 5, [3.3] are to be complied with.
- j) It is recommended that the towing winch is fitted with equipment to continuously measure the tension in the towline.

In case a towline measurement system is installed on board, the measured data are to be displayed in the wheelhouse next to the control desk or another appropriate location.

2.7.4 Emergency release system

- a) The emergency release system shall be operable under all normal and reasonably foreseeable abnormal conditions (these may include, but are not limited to, the following: vessel electrical failure, extreme list/trim angles, load applied at the limits of operating load, fleet angle, variable load (for example due to heavy weather), etc.).
- b) The emergency release system is to allow the winch drum to rotate and allow the towline to pay out in a controlled manner.
- c) An alternative source of energy shall be provided such that normal operation of the emergency release system can be sustained under dead-ship conditions, for at least three complete emergency release system operations of the most demanding winch connected to it.
- d) Where the winch design is such that the brake is applied by spring tension and released using hydraulic or pneumatic power, sufficient power is to be provided to operate the emergency release system, in a dead-ship situation, for a minimum of five minutes. This may be reduced to the time required for the full length of the towline to feed off the winch drum at the minimum load as specified in g) if this is less than five minutes.

Note 1: After the emergency release system has been activated it is considered good practice for the brake to first completely open and then automatically tighten slightly to ensure a controlled release of the towline.

- e) The emergency release system is to function as quickly as reasonably practicable and within a maximum of three seconds after activation.
- f) Arrangements shall ensure that when emergency release system is activated, there is sufficient resistance to rotation to avoid uncontrolled unwinding of the towline from the drum.
- g) The towline load required to rotate the winch drum is to be no greater than:
 - the lesser of five tonnes or five per cent of the maximum BHL of the associated winch (see Ch 1, Sec 1, [2.4]) when two layers of towline are on the drum, or
 - 15% of the BHL of the associated winch (see Ch 1, Sec 1, [2.4]) where it is demonstrated that the resistance to rotation does not exceed 25% of the force that will result in listing sufficiently to immerse of the lowest unprotected opening.
- h) The emergency release system shall be capable of operating at 100 per cent of the BHL of the associated winch (see Ch 1, Sec 1, [2.4]).
- i) Emergency release operation must be possible from the bridge and from the winch control station on deck. The winch control station on deck shall be in a safe location.
- j) The emergency release control is to be located in close proximity to the emergency stop button for winch operation and both should be clearly identifiable, clearly visible, easily accessible and positioned to allow safe operability.
- k) The emergency release function is to take priority over any emergency stop function. Activation of the winch emergency stop from any location shall not inhibit operation of the emergency release system from any location.
- l) Emergency release system control buttons are to be of the 'lock-in' type or require positive action to cancel.
- m) Controls for emergency use are to be protected against accidental use.
- n) The following emergency release system alarms and indications are to be provided on the bridge:
 - Low fluid pressure in the control system
 - Low accumulator/ air pressure
 - Low battery voltage (separate alarm and indication not required where electrical power is supplied from the tug's emergency batteries).
- o) Wherever practicable, control of the emergency release system is to be provided by a hard-wired system, fully independent of programmable electronic systems.

- p) Programmable electronic systems that operate or may affect the control of emergency release systems are to be considered Category III systems (see Pt C, Ch 3, Sec 3, [1.7]).
- q) The emergency release system reset function is to be always available from the bridge regardless of the activation location and without manual intervention on the working deck.
- r) Components which are critical for the safe operation of the emergency release system are to be identified by the manufacturer.
- s) The method for annual survey of the winch is to be documented and adequately sized strong points are to be provided on deck if required.

2.7.5 Towing hooks

- a) Towing hooks and their load carrying attachments (connecting the towing hook to the hull structure) shall be able to sustain the DL, as specified in [2.7.2], without exceeding an equivalent stress level (based on Von Mises criterion) of $0,80 R_{eH}$.
- b) Towing hooks shall be provided with an emergency release system operable from a position on the bridge with full view and control of the towing operation, as well as at a location near the hook where the device can be safely operated. Identical means of control for the emergency release systems shall be provided at each control station and are to be protected against unintentional use.

The force necessary to open the hook under load is to be not greater than 150 N.

The applicable procedures for the emergency quick-release device shall be communicated to the crew and vital information shall be displayed next to the control desk or another appropriate location.

2.7.6 Towlines

- a) The breaking strength of towlines is not to be less than the DL, as specified in [2.7.2].
In addition, the breaking strength of towlines used on a towing winch is not to be less than the BHL of the associated winch (see Ch 1, Sec 1, [2.4]).
- b) The towline shall be protected from being damaged by chafing and abrasion. To this end cargo rails, bulwarks, and other elements supporting the towline should be sufficiently rounded with consideration to the bend radius limit of the towline in order to ensure that the towline breaking strength is maintained.
- c) It is recommended that the total length of the towline applied on a towing winch is such that under normal operation, at least half a layer remains on the drum. In no case less than three turns shall remain on the drum in under normal operation.

2.7.7 Towline guiding fittings

- a) Towline guiding fittings, such as fairleads, staples, gobyes, towing pins, stern rollers and equivalent components which guide the towline, shall be able to sustain

the force exerted by the towline loaded under a tension equal to the DL, as specified in [2.7.2], in the most unfavourable anticipated position of the towline without exceeding the following stress level criteria:

- Normal stress: $\sigma \leq 0,75 R_{ref}$
- Shear stress: $\tau \leq 0,47 R_{ref}$
- Equivalent stress: $\sigma_{VM} \leq 0,85 R_{ref}$

where:

R_{ref} : Reference stress of the material, in N/mm^2 , normally to be taken as 235/k, but may be taken as R_{eH} for fittings not made of welded construction.

- b) Towline guiding fittings used for guiding the towline when towing on a towing winch shall be able to sustain the force exerted by the towline loaded under a tension equal to the BHL of the associated winch, as specified in Ch 1, Sec 1, [2.4], in the most unfavourable anticipated position of the towline without exceeding the stress level criteria mentioned in a).
- c) Where a towline guiding fitting (e.g. fairlead or guide pin) has been designed for a specific Safe Working Load SWL, defined as the maximum static working load, the fitting shall be able to sustain a force equal to 2 times the SWL without exceeding the stress level criteria mentioned in a).
- d) In case the yielding check of the towline guiding fittings is carried out by means of a three dimensional finite element model, the permissible stress levels given above may be increased by 10 per cent (compared to a beam model).

2.7.8 Supporting structures

- a) The supporting structures of towing equipment shall be able to sustain the load exerted on the supporting structure under the action of the towline loaded under a tension equal to the DL, as specified in [2.7.2], in the most unfavourable anticipated position of the towline, without exceeding the stress level criteria specified in [2.7.7].
- b) Supporting structures of towing equipment engaged when towing on a towing winch shall be able to sustain the load exerted on the supporting structure under the action of the towline loaded under a tension equal to the BHL of the associated winch, as specified in Ch 1, Sec 1, [2.4], in the most unfavourable anticipated position of the towline without exceeding the stress level criteria specified in [2.7.7].
- c) Where a towline guiding fitting has been designed for a specific Safe Working Load SWL, defined as the maximum static working load, the associated supporting structure shall be able to sustain a force equal to 2 times the SWL without exceeding the stress level criteria specified in [2.7.7].
- d) In case the yielding check of the towing equipment supporting structures is carried out by means of a three dimensional finite element model, the permissible stress levels given above may be increased by 10 per cent (compared to a beam model).

Table 3 : Design Loads for equipment used for escort operations and supporting structures

$T_{ESC,MAX}$ in kN	DL, in kN	
	General case	Escort tugs assigned with the operating area notation escort service limited to non-exposed waters
≤ 500	$3 T_{ESC,MAX}$	$2,4 T_{ESC,MAX}$
$500 < T_{ESC,MAX} \leq 1000$	$[(2000 - T_{ESC,MAX}) / 500] T_{ESC,MAX}$	$[(2000 - T_{ESC,MAX}) / 625] T_{ESC,MAX}$
> 1000	$2 T_{ESC,MAX}$	$1,6 T_{ESC,MAX}$

Note 1: The DL takes into consideration dynamic effects through the application of the Dynamic Amplification Factor (DAF) (see also Ch 1, Sec 1, [2.3]).

2.7.9 Fendering

- A robust and efficient fendering system is to be fitted in areas intended for pushing. The fendering system purpose is to distribute the pushing force and limit its dynamic component on the hull structure of both the tug and the assisted ship.
- For the purpose of this requirement, it is considered that during pushing operations, the contact between the tug and the assisted ship is maintained and that no bouncing (e.g. under wave action) is taking place. Forces resulting from bouncing loads are not taken into consideration, as it is understood that pushing operations (in waves) are normally halted when bouncing starts taking place (due to operational difficulties to keep position within the pushing area of the assisted ship as well as to control the associated impact type loads).
- The design load DL to be considered for the strength assessment of the fender supporting structure may be taken as follows:

$$DL = 1,5 T_{BP}$$

where:

T_{BP} : Design bollard pull, as defined in Ch 1, Sec 1, [2.1].

The DL takes into consideration anticipated dynamic effects through the application of the dynamic amplification factor (see also Ch 1, Sec 1, [2.3]), but not bouncing effects (see above).

The fender supporting structure shall be able to sustain the DL, as specified above, without exceeding the stress level criteria specified in [2.7.7].

3 Additional requirements for escort tugs

3.1 Structural design principles

3.1.1 Hull shape

The hull shape is to be such as to provide adequate hydrodynamic lift and drag forces and to avoid excessive trim angles for large heeling angles.

3.1.2 Bulwark

A bulwark is to be fitted all around the weather deck.

3.2 Equipment for escort operations

3.2.1 General

Towing winches and towline guiding fittings (fairleads, staples, etc.) used for escort services are normally to be arranged in way of the tug's centreline, in such a position as to minimise heeling moment.

Materials used in towing equipment are to comply with the applicable class requirements for materials. Class certificates are required for the materials used for winch drums, drum shafts, winch brake components, winch supporting frames and towline guiding fittings.

3.2.2 Design load

The design load DL to be considered for the strength assessment of the towing equipment used for escort services and the associated supporting structures is given in Tab 3.

3.2.3 Escort winches

- The winch brake shall normally act directly on the drum and shall be operable in case of failure of the primary power supply system (either manually or otherwise arranged).
- Escort winches intended to be used in conditions where dynamic oscillations of the towline are likely to occur, such as in open sea areas or other areas exposed to waves, are to be equipped with an active pay-out and haul-in system.

This system is to automatically and reliably pay-out the towline in a controlled manner when the towline force exceeds a pre-set (adjustable) level equal to 110 per cent of the rated towline force $T_{ESC,R}$ and, as the towline force is reduced, actively haul-in the towline to prevent slack-line events and maintain a pre-set or adjustable towline force consistent with the rated towline force.

Pay-out and haul-in speeds and pull capability shall be chosen taking into account the anticipated escort services and the dynamic characteristics of the escort tug.

- Escort operations in conditions where dynamic oscillations of the towline are likely to occur may not be based on the use of the brakes of the winch drum.

d) Escort operations performed by escort tugs with the operating area notation **escort service limited to non-exposed waters** and any escort operation in calm water conditions, such as in ports and sheltered (confined) waters, may be based on the use of the brakes of the winch drum. As a minimum, the winch brake holding load BHL is to be equal to or greater than two times the maximum steady towline force $T_{ESC,MAX}$.

e) Escort winches are to be fitted with equipment to continuously measure the tension in the towline.

The measured data are to be displayed in the wheelhouse next to the control desk or another appropriate location.

f) The escort towing system is to be designed so as to enable the proper spooling of the towline on the winch drum when hauling in. Generally this can be achieved by a suitable design of the fairlead or staple guiding the towline between the escort winch and the assisted ship.

Where a spooling device is fitted, this device should be designed for the same Design Load and stress criteria as the towline guiding fittings, see [3.2.5].

g) Winches are to be provided with an emergency release system as defined in [2.7.4].

h) The dimensioning of the winch drum is to take into account the rope bending specifications provided by the towline manufacturer.

Due consideration is to be given to preventing the towline to slip over the flanges of the drum.

i) Escort winches (in particular the components which are exposed to the tension in the towline, such as the winch drums, drum shafts, brakes, support frame and connection to the hull structure) shall be able to:

- sustain the DL, as specified in [3.2.2] without permanent deformation, and
- sustain the BHL, as defined in Ch 1, Sec 1, [2.4], without exceeding an equivalent stress level (based on Von Mises criterion) of $0,80 R_{eH}$
- sustain the loads for the rated pull condition, as foreseen by the Designer, without exceeding an equivalent stress level (based on Von Mises criterion) of $0,40 R_{eH}$.

where:

R_{eH} : Minimum specified yield stress of material, in N/mm^2

rated pull: Winch maximum hauling in load at the first inner layer.

j) Where deemed necessary by the Society, buckling and/or fatigue analysis, performed in accordance with a standard or code of practice recognized by the Society, may be required to be submitted for information.

3.2.4 Towlines

a) The breaking strength of towlines used for escort services is not to be less than the DL, as specified in [3.2.2].

In addition, the breaking strength for towlines used for escort services on an escort winch is not to be less than the BHL of the associated escort winch (see Ch 1, Sec 1, [2.4]).

b) The towline shall be protected from being damaged by chafing and abrasion. To this end cargo rails, bulwarks, and other elements supporting the towline should be adequately rounded.

c) It is recommended that the total length of the towline applied on a towing winch is such that under normal operation, at least half a layer remains on the drum. In no case less than three turns shall remain on the drum in under normal operation.

3.2.5 Towline guiding fittings

a) Towline guiding fittings used for escort services, such as fairleads, staples and equivalent components which guide the towline, shall be able to sustain the force exerted by the towline loaded under a tension equal to the DL, as specified in [3.2.2], in the most unfavourable anticipated position of the towline without exceeding the stress level criteria specified in [2.7.7].

b) In addition, towline guiding fittings shall be able to sustain the force exerted by the towline loaded under a tension equal to the BHL of the associated winch, as specified in Ch 1, Sec 1, [2.4], in the most unfavourable anticipated position of the towline without exceeding the stress level criteria specified in [2.7.7].

c) Where a towline guiding fitting has been designed for a specific safe working load SWL, defined as the maximum static working load, the fitting shall be able to sustain a force equal to 2 times the SWL without exceeding the stress level criteria specified in [2.7.7].

d) In case the yielding check of the towline guiding fittings is carried out by means of a three dimensional finite element model, the permissible stress levels given above may be increased by 10 per cent (compared to a beam model).

3.2.6 Supporting structures

a) The supporting structures of towing equipment used for escort services shall be able to sustain the load exerted on the supporting structure under the action of the towline loaded under a tension equal to the DL, as specified in [3.2.2], in the most unfavourable anticipated position of the towline, without exceeding the stress level criteria specified in [2.7.7].

b) In addition, supporting structures of towing equipment used for escort services shall be able to sustain the load exerted on the supporting structure under the action of the towline loaded under a tension equal to the BHL of the associated winch, as specified in Ch 1, Sec 1, [2.4], in the most unfavourable anticipated position of the towline without exceeding the stress level criteria specified in [2.7.7].

- c) Where a towline guiding fitting has been designed for a specific safe working load SWL, defined as the maximum static working load, the associated supporting structure shall be able to sustain a force equal to 2 times the SWL without exceeding the stress level criteria specified in [2.7.7].
- d) In case the yielding check of the towing equipment supporting structures is carried out by means of a three dimensional finite element model, the permissible stress levels given above may be increased by 10 per cent (compared to a beam model).

4 Additional requirements for salvage tugs

4.1 Equipment

4.1.1 Ships with the navigation notation salvage tug are to be fitted with the additional equipment specified in Tab 4.

Table 4 : Additional equipment for salvage tugs

Arrangement or equipment	Number of items
Fixed or movable drainage pumps having approximately the same capacity (1) (2) (3)	2 or more pumps of total capacity $\geq 400 \text{ m}^3/\text{h}$
Fire pumps each capable of throwing two simultaneous jets of water having a horizontal reach not less than 30 m (4)	2 pumps, each having a capacity $\geq 60 \text{ m}^3/\text{h}$
Breathing apparatuses for divers	2
Gas masks with filter	2
Cargo boom	1, with service load $\geq 1 \text{ t}$
Power operated winch capable of producing an adequate pull	1
Water stops to stop leaks of approximately 1 x 2 m	4
Complete set of equipment for flame cutting with at least 25 metres of flexible piping	1
Drain hoses	at least 20 m per pump
Fire hoses	10
Connections for fire main	at least 3
Power operated diver's compressor, with associated equipment (5)	1
Additional towline equipment	1
Lamps for underwater operation	2
Floodlight of power $\geq 500 \text{ W}$	1
Working lamps	2
Winding drums with wire ropes	see (6)
Electrical cables, each not less than 100 metres long and capable of supplying at least 50 kW	3
Tackles with lifting capacity of 1 t	2
Tackles with lifting capacity of 3 t	2
Radar with a range not less than 24 nautical miles	1
Echo-sounding device with a range of 100 m	1
Hydraulic jackets with lifting capacity of 10 t	2
Hydraulic jackets with lifting capacity of 20 t	2
Portable electrical drill with a set of twist bits having diameters up to 20 mm	1
<p>(1) For each pump fitted on board, a suction strainer and, in the case of non self-priming pumps, a foot valve, are also to be provided.</p> <p>(2) Where portable pumps are used, they are to be capable of effectively operating even with transverse and longitudinal inclinations up to 20°.</p> <p>(3) These pumps are additional to the drain pumps intended for the drainage service of the ship.</p> <p>(4) These pumps may be the same required for drainage purposes provided they have an adequate head.</p> <p>(5) As an alternative, a compressor for recharging the oxygen tanks of divers may be provided together with two complete sets of equipment for divers.</p> <p>(6) Winding drums fitted on board are to be capable of housing wire ropes of suitable size and length not normally less than 350 m.</p>	

SECTION 4 INTEGRATED TUG/BARGE COMBINATION

Symbols

R_y	: Minimum yield stress, in N/mm ² , of the material, to be taken equal to 235/k N/mm ² , unless otherwise specified
k	: Material factor for steel, defined in Pt B, Ch 4, Sec 1, [2.3]
R_{eH}	: Yield stress, in N/mm ² , of the steel used, and not exceeding the lower of 0,7 R_m and 450 N/mm ²
R_m	: Minimum ultimate tensile stress, in N/mm ² , of the steel used.

1 General

1.1 Application

1.1.1 General

The requirements of this Section apply to the integrated tug/barge combinations constituted by:

- a tug, to which the additional service feature **barge combined** is assigned
- a barge, to which the additional service feature **tug combined** is assigned

and specify the criteria these combinations are to satisfy in addition to those in:

- Ch 1, Sec 3, [2], Ch 1, Sec 2, [3] and Ch 1, Sec 5, [2] for the tug
- Pt D, Ch 14, Sec 2 for the barge.

1.1.2 When a series of barges may be operated in combination with a specific tug, the identification numbers of such barges are to be indicated in the tug class certificate.

1.1.3 When a series of tugs may be operated in combination with a specific barge, the identification numbers of such tugs are to be indicated in the barge Certificate of Classification.

1.2 Permanent connections

1.2.1 An integrated tug/barge combination is connected with permanent connection if the tug and the barge cannot be disconnected in open sea. The connection is such that no relative motion between the tug and the barge is permitted.

1.3 Removable connections

1.3.1 General

An integrated tug/barge combination is connected with removable connection if the tug and the barge can be disconnected in open sea. The disconnecting procedure is to be performed safely by one man and is to take less than 5 min. After disconnection in open sea, the tug is to be arranged to tow the barge by hawser.

The procedure for disconnecting and reconnecting at sea the integrated tug/barge combination is to be made available for guidance to the Master.

1.3.2 Types of removable connections

The removable connection is classed in the two following types:

- rigid connection, if no relative motion between the tug and the barge is permitted
- flexible connection, if relative motion between the tug and the barge is permitted (e.g. the tug is free to pitch with respect to the barge).

1.3.3 Tug

The tug is to have the capability of separating from the barge and shifting to tow it by hawser.

1.4 Documents to be submitted

1.4.1 In addition to the documentation requested in Part B, the following documents are to be submitted:

- Structural arrangement of the fore part of the tug, showing details of reinforcements in way of the connecting point,
- Structural arrangement of the aft part of the barge, showing details of reinforcements in way of the connecting point,
- Details of the connection system.

2 General arrangement design

2.1 Bulkhead arrangement

2.1.1 Number and disposition of tug transverse watertight bulkheads

The tug is to be fitted with transverse watertight bulkheads according to Pt B, Ch 2, Sec 1.

2.1.2 Number and disposition of barge transverse watertight bulkheads

In applying the criteria in Pt B, Ch 2, Sec 1, [4], the barge is to be fitted at least with an aftermost transverse watertight bulkhead located forward of the connection area and extended from side to side.

The cargo spaces are to be separated from the other spaces not used for cargo by watertight bulkheads.

2.1.3 Barge collision bulkhead

The collision bulkhead of the barge is to be located at a distance, in m, from the fore end of L of not less than $0,05 L_{LLC}$ or 10 m, whichever is the lesser, and not more than $0,08 L_{LLB}$, where:

L_{LLC} : Ship's length, in m, measured between the aft and fore ends of L of the integrated tug/barge combination, taken at the fore and aft ends of the load line length

L_{LLB} : Ship's length, in m, measured between the aft and fore ends of L of the barge considered as an individual ship, taken at the fore and aft ends of the load line length.

3 Integrated tug/barge combinations with permanent connection: stability, freeboard, design loads, hull scantlings and equipment

3.1 Stability calculations

3.1.1 The integrated tug/barge combination is to comply with the applicable intact and, where additional notation SDS is requested, damage stability requirements in Part B, Chapter 3 considering the integrated tug/barge combination as a ship of the size of the combination.

3.2 Freeboard calculation

3.2.1 The freeboard is to be taken as the greatest of:

- the freeboard of the tug, considered as an individual ship
- the freeboard of the barge, considered as an individual ship
- the freeboard of the integrated tug/barge combination, considered as a ship of the size of the combination. For the freeboard calculation the barge is to be considered as being manned.

3.3 Still water hull girder loads

3.3.1 The still water hull girder loads and the forces transmitted through the connection are to be calculated for each loading condition considering the integrated tug/barge combination as a ship of the size of the combination.

3.4 Wave hull girder loads

3.4.1 The wave hull girder loads and the forces transmitted through the connection are to be calculated according to Pt B, Ch 5, Sec 2 considering the integrated tug/barge combination as a ship of the size of the combination.

3.4.2 Direct calculation

When deemed necessary by the Society, the wave hull girder loads and the forces transmitted through the connection are to be obtained from a complete analysis of the integrated tug/barge combination motion and acceleration in irregular waves, unless such data are available from similar ships.

These loads are to be obtained as the most probable the integrated tug/barge combination, considered as a ship of the size of the combination, may experience during its operating life for a probability level of 10^{-8} . For this calculation, the wave statistics relevant to the area of navigation and/or worst weather condition expressed by the navigation notation assigned to the integrated tug/barge combination are to be taken into account. For unrestricted navigation, the wave statistics relevant to the North Atlantic are to be taken into account.

When the difference between the tug and the barge depths is not considered negligible by the Society, its effects are to be considered in evaluating the buoyancy force distributions and the corresponding hull girder loads on the tug structures immediately aft of the connection section, for the different wave encountering conditions.

3.5 Still water local loads

3.5.1 The still water local loads are to be calculated according to Pt B, Ch 5, Sec 5 for each loading condition and draught of the integrated tug/barge combination. The draught of the integrated tug/barge combination is to be taken not less than $0,85 D$, where D is the greater of the tug and the barge depths and not greater than the draught of the barge.

3.6 Wave local loads

3.6.1 The wave local loads are to be calculated according to Pt B, Ch 5, Sec 5, [2] considering the integrated tug/barge combination as a ship of the size of the combination. The draught of the integrated tug/barge combination is to be taken not less than $0,85 D$, where D is the greater of the tug and the barge depths and not greater than the draught of the barge.

3.7 Hull girder strength

3.7.1 Strength check

The longitudinal strength is to comply with Part B, Chapter 6, where the hull girder loads are those defined in [3.3] and [3.4].

3.7.2 Loading manual

The loading manual is to include the (cargo and ballast) loading conditions of the integrated tug/barge combination at sea and in port conditions on the basis of which the approval of its hull structural scantlings is based.

The manual is to indicate the still water bending moment and shear force along the length of the integrated tug/barge combination as well as the permissible values at each hull section.

Information on loading and unloading sequences is to be provided for guidance to the Master.

3.8 Scantlings of plating, ordinary stiffeners and primary supporting members

3.8.1 The scantlings of plating, ordinary stiffeners and primary supporting members are to be in accordance with Part B, Chapter 7 or NR600, as applicable, where the hull girder and local loads are those defined in [3.3] to [3.6].

In any case, the scantlings of plating, ordinary stiffeners and primary supporting members of the tug and the barge are to be not less than those obtained according to Ch 1, Sec 3 and Pt D, Ch 14, Sec 2 for the tug alone and the barge alone, respectively.

3.9 Equipment

3.9.1 The equipment is to be in accordance with the requirements in both

- Ch 1, Sec 3, [2.6] for the tug, and
- Pt D, Ch 14, Sec 2, for the barge, considering the barge as a ship of the size of the integrated tug/barge combination.

4 Integrated tug/barge combination with removable connection: stability, freeboard, design loads, hull scantlings and equipment

4.1 Stability calculations

4.1.1 The integrated tug/barge combination is to comply with the applicable intact stability requirement in Part B, Chapter 3, considering the integrated tug/barge combination as a ship of the size of the combination.

4.2 Freeboard calculation

4.2.1 The freeboard is to be calculated for the tug and the barge considered as individual ships.

4.3 Still water hull girder loads

4.3.1 General

The still water hull girder loads and the forces transmitted through the connection are to be calculated for each loading condition considering the integrated tug/barge combination as a ship of the size of the combination.

4.3.2 Integrated tug/barge combination with removable flexible connection

For integrated tug/barge combinations with removable flexible connection, the effect of the degrees of freedom of the connection on the still water hull girder loads in the combination may be taken into account (e.g. free pitch of the tug with respect to the barge implies vertical bending moment equal to zero in the connection).

4.4 Wave hull girder loads

4.4.1 The wave hull girder loads and the forces transmitted through the connection are to be calculated according to [3.4].

4.4.2 Integrated tug/barge combination with removable flexible connection

For integrated tug/barge combinations with removable flexible connection, the effect of the degrees of freedom of the connection on the wave hull girder loads in the combination may be taken into account (e.g. free pitch of the tug with respect to the barge implies vertical bending moment equal to zero in the connection).

4.5 Still water local loads

4.5.1 The still water local loads are to be calculated according to Pt B, Ch 5, Sec 5 or NR600, as applicable, for each loading condition and draught of the integrated tug/barge combination. The draught of the integrated tug/barge combination is to be taken not less than $0,85 D$, where D is the greater of the tug and the barge depths and not greater than the draught of the barge.

4.6 Wave local loads

4.6.1 The wave local loads are to be calculated according to Pt B, Ch 5, Sec 5, [2] considering the integrated tug/barge combination as a ship of the size of the combination. The draught of the integrated tug/barge combination is to be taken not less than $0,85 D$, where D is the greater of the tug and the barge depths and not greater than the draught of the barge.

4.7 Hull girder strength

4.7.1 The longitudinal strength is to comply with Part B, Chapter 6, where the hull girder loads are those defined in [4.3] and [4.4].

4.7.2 Loading manual

The loading manual is to include the items specified in [3.7.2].

4.8 Scantlings of plating, ordinary stiffeners and primary supporting members

4.8.1 Integrated tug/barge combinations with removable rigid connection

For integrated tug/barge combinations with removable rigid connection, the scantlings of plating, ordinary stiffeners and primary supporting members are to be in accordance with Part B, Chapter 7 or NR600, as applicable, where the hull girder and local loads are those defined in [4.3] to [4.6].

In any case, the scantlings of plating, ordinary stiffeners and primary supporting members of the tug and the barge are to be not less than those obtained according to Ch 1, Sec 3, for the tug alone, and Pt D, Ch 14, Sec 2 for the barge alone.

4.8.2 Integrated tug/barge combinations with removable flexible connection

For integrated tug/barge combinations with removable flexible connection, the scantlings of plating, ordinary stiffeners and primary supporting members of the tug and the barge are to be not less than those obtained according to Ch 1, Sec 3 and Pt D, Ch 14, Sec 2 for the tug alone and the barge alone, respectively.

4.9 Equipment

4.9.1 The equipment is to be in accordance with [3.9.1].

5 Connection

5.1 General

5.1.1 The components of the connecting/disconnecting system are to be fitted on the tug.

Where the connecting system is located on a tug superstructure, this is to be checked according to Pt B, Ch 8, Sec 4 or NR600, as applicable. The efficiency of the structural connection between this superstructure and the underlying hull structures is to be ensured.

5.1.2 The connecting system is to comply with the following requirements:

- it is to be permanently locked in position, at sea, with remote indication and control on the bridge
- it is to remain locked in the event of damage to the control system. A local control is to be provided for enabling the disconnection from the coupler machinery room.

5.2 Scantlings

5.2.1 General

The bow of the tug and the stern of the barge are to be reinforced in order to withstand the connection forces.

The structure reinforcements are to be continued in aft and fore directions of the integrated tug/barge combination in order to transmit the connection forces to the hull structure of the tug and the barge.

5.2.2 Calculation of stresses in the connection

The stresses in the connection are to be obtained by means of direct calculations, where the connection forces are to be obtained according to [3.3] and [3.4] or [4.3] and [4.4], as applicable, and the partial safety factors specified in Tab 1 are to be applied.

When calculating the stresses in the connection, pre-loading from locking devices, if any, is to be taken into account.

For notch type connections, the analysis of the barge wing walls is to take into account the effects of bending moment, shear force and torque.

5.2.3 Shear check of the structural elements of the connection

The shear stresses in the structural elements of the connection are to comply with the following formula:

$$\tau \leq 0,65 \frac{R_Y}{\gamma_R \gamma_m}$$

where:

τ : Shear stress, in N/mm², to be obtained as a result of direct calculations

γ_R : Resistance partial safety factor, defined in Tab 1

γ_m : Material partial safety factor, defined in Tab 1.

Table 1 : Partial safety factors

Partial safety factors covering uncertainties regarding	Symbol	Partial safety factor value
Still water hull girder loads	γ_{S1}	1,00
Wave hull girder loads	γ_{W1}	1,15
Still water pressure	γ_{S2}	1,00
Wave pressure	γ_{W2}	1,20
Material	γ_m	1,02
Resistance	γ_R	1,25

5.2.4 Yielding check of the structural elements of the connection

The Von Mises equivalent stresses in the structural elements of the connection are to comply with the following formula:

$$\sigma_E \leq \frac{R_Y}{\gamma_R \gamma_m}$$

where:

σ_E : Von Mises equivalent stress, in N/mm², to be obtained as a result of direct calculations

γ_R : Resistance partial safety factor, defined in Tab 1

γ_m : Material partial safety factor, defined in Tab 1.

5.2.5 Deflections

Deflections of the structural elements in the connection are to be obtained from direct calculations, to be carried out in accordance with [5.2.2] and submitted to the Society for review.

Deflection and pre-loading of the connection, if any, are to be considered in order to avoid hammering in the connection area.

6 Other structures

6.1 Tug fore part

6.1.1 General

For integrated tug/barge combinations with permanent connection or removable rigid connection, the tug fore structure is to be aligned with the barge aft structure in way of the notch or the dock bottom.

6.1.2 Scantlings

The scantlings of the fore part of the tug are to be in accordance with Part B, Chapter 7 or NR600, as applicable, considering the hull girder loads, the local loads and the connection forces defined in [3.3] to [3.6] for integrated tug/barge combinations with permanent connection or [4.3] to [4.6] for integrated tug/barge combinations with removable connection.

6.2 Tug aft part

6.2.1 Scantlings for integrated tug/barge combinations with permanent or removable rigid connections

The scantlings of the aft part of the tug are to be in accordance with Pt B, Ch 8, Sec 2 or NR600, as applicable, considering this part as belonging to a ship of the size of the integrated tug/barge combination.

6.2.2 Scantlings for integrated tug/barge combinations with removable flexible connections

The scantlings of the aft part of the tug are to be in accordance with Pt B, Ch 8, Sec 2 or NR600, as applicable, considering the tug as an individual ship.

6.3 Barge fore part

6.3.1 Scantlings for integrated tug/barge combinations with permanent or removable rigid connections

The scantlings of the fore part of the barge are to be in accordance with Pt B, Ch 8, Sec 1 or NR600, as applicable, considering this part as belonging to a ship of the size of the integrated tug/barge combination.

6.3.2 Scantlings for integrated tug/barge combinations with removable flexible connections

The scantlings of the fore part of the barge are to be in accordance with Pt B, Ch 8, Sec 1 or NR600, as applicable, considering the barge as an individual ship.

6.4 Barge aft part

6.4.1 General

For integrated tug/barge combinations with permanent connection or removable rigid connection, the barge aft structure is to be aligned with the tug fore structure in way of the notch or the dock bottom.

6.4.2 Scantlings

The scantlings of the aft part of the barge are to be in accordance with Part B, Chapter 7 or NR600, as applicable, considering the hull girder loads, the local loads and the connection forces defined in [3.3] to [3.6] for integrated tug/barge combinations with permanent connection or [4.3] to [4.6] for integrated tug/barge combinations with removable connection.

7 Hull outfitting

7.1 Rudder and steering gear

7.1.1 The tug rudder and steering gear are to be in accordance with Pt B, Ch 9, Sec 1 and Pt C, Ch 1, Sec 11, respectively, considering the maximum service speed (in ahead and astern condition) of the tug as an individual ship and the maximum service speed (in ahead and astern condition) of the integrated tug/barge combination.

The characteristics and performance of the rudder and the steering gear are to ensure the manoeuvrability of the integrated tug/barge combination.

8 Construction and testing

8.1 Test of the disconnection procedure of removable connection

8.1.1 Tests are to be carried out in order to demonstrate the capability of the tug to be safely disconnected from the barge within 5 min by one man.

These tests may be performed in harbour. However, additional information is to be submitted to the Society in order to demonstrate the capability of the tug and the barge of being safely disconnected and reconnected at sea. The operating procedure, indicating the maximum or pre-fixed sea states, is to be made available for guidance to the Master, as indicated in [1.3.1].

SECTION 5

TESTING

1 General

1.1 Application

1.1.1 The requirements of this Section apply as follows depending on the ship service notation:

- **tug**, mainly intended for towing services, are to comply with the requirements in Article [2]
- **salvage tug**, having specific equipment for salvage services, are to comply with the requirements in Article [2]
- **escort tug**, mainly intended for escort services such as for steering, braking and otherwise controlling escorted ships, are to comply with the requirements in Articles [2] and [3]

In addition, ships with the additional service feature **barge combined** are to comply with the applicable requirements in Ch 1, Sec 4.

2 General requirements

2.1 Bollard Pull test

2.1.1 The design bollard pull is to be verified by means of a bollard pull test performed in accordance with a recognized standard.

In the case of sister ship, the results obtained from the tests carried out on the prototype ship may be considered if deemed relevant.

2.1.2 For tugs capable of towing over the stern (ahead towing) as well as over the bow (astern towing), the bollard pull test is to be performed for both.

2.1.3 The measured Bollard Pull is to be not less than 3% lower and not more than 1% higher than the design bollard pull specified in Pt A, Ch 1, Sec 2, [4.7], otherwise the design bollard pull is to be amended accordingly.

In case the measured bollard pull is more than 1% higher than the design bollard pull, it is to be demonstrated by the Designer that the applicable hull structure and stability requirements of this Chapter are complied with.

2.1.4 The bollard pull test is to be carried out in the presence of a Surveyor of the Society, using suitable equipment (e.g. electrical load cell equipment) capable of providing, at any time during the test, a readout of the bollard pull developed by the tug and a record, in numerical or graphical form, of the values measured. The test procedure location and conditions (environmental conditions, tug trim, etc.) are to be agreed with the Society.

2.2 Towing winches

2.2.1 Towing winches, including the associated emergency release systems are to be load tested at the DL, as defined in Ch 1, Sec 3, [2.7.2], or at the BHL, as defined in Ch 1, Sec 1, [2.4], whichever is the greatest, unless a complete calculation verifying that all the load bearing parts of the winch comply with the requirements in Ch 1, Sec 3, [2.7.3] is submitted to the Society for information and is deemed acceptable.

Generally, load testing is to be conducted at a special facility equipped to generate the required line tension (e.g. maker's premises) and to be witnessed by the Society.

In case a towing winch is of conventional, proven design, for which load testing has been previously performed and deemed acceptable by the Society, it is sufficient to perform on board function testing in accordance with [2.2.2].

Note 1: The Society may request the winch manufacturer to supply records of the load tests performed.

2.2.2 Towing winches are to be function tested on board.

The correct functioning of the winch brake, the load carrying winch components and the associated supporting structure is to be demonstrated at a towline force equal to the design bollard pull, as defined in Ch 1, Sec 1, [2.1].

Winch operating modes to be function tested include hauling in and paying out of the towline, as well as braking.

Hydraulic and electrical systems shall be function tested on board in accordance with the Society's requirements for machinery and electrical systems.

2.3 Towing hooks

2.3.1 Towing hooks, including the associated emergency release systems, are normally to be load tested at the DL, as defined in Ch 1, Sec 3, [2.7.2], unless complete calculation verifying that the hook complies with the requirements in Ch 1, Sec 3, [2.7.5] is submitted to the Society for information and is deemed acceptable.

Generally, load testing is to be conducted at a special facility equipped to generate the required line tension (e.g. maker's premises) and to be witnessed by the Society.

In case a towing hook is of conventional, proven design, for which load testing has been previously performed and deemed acceptable by the Society, it is sufficient to perform on board function testing in accordance with [2.3.2].

Note 1: The Society may request the winch manufacturer to supply records of the load tests performed.

2.3.2 Towing hooks are to be function tested on board. The correct functioning of the hook and the associated supporting structure is to be demonstrated at a towline force equal to the design Bollard Pull, as defined Ch 1, Sec 1, [2.1].

2.4 Emergency release system

2.4.1 For each emergency release system or type thereof, the performance requirements of Ch 1, Sec 3, [2.7.4] are to be verified either at the manufacturer's works or as part of the commissioning of the towing winch when it is installed on board. Where verification solely through testing is impracticable (e.g. due to health and safety), testing may be combined with inspection, analysis or demonstration on a case-by-case basis.

2.4.2 The performance capabilities of the emergency release system are to be documented and made available on board the ship on which the winch has been installed.

2.4.3 The full functionality of the emergency release system is to be tested as part of the shipboard commissioning trials to the satisfaction of the surveyor. Testing may be conducted either during a Bollard Pull test or by applying the towline load against a strong point on the deck of the tug that is certified to the appropriate load.

2.4.4 Where the performance of the winch in accordance with Ch 1, Sec 3, [2.7.4] has previously been verified, the load applied for the installation trials is not to be lower than 30% of the BHL of the associated winch, as specified in Ch 1, Sec 1, [2.4].

2.4.5 For novel or particular designs the emergency release systems are also to be load tested with the towline at an upward angle of 45 degrees with the horizontal plane at a towline force of not less than 50 per cent of the design bollard pull, as defined Ch 1, Sec 1, [2.1].

3 Additional requirements for escort tugs

3.1 Escort performance simulations

3.1.1 Where the highest anticipated heeling moment is obtained from the results of a computer simulation program, the basic assumptions and theoretical models underlying the software are to be presented in detail to the Society. Items to be addressed include:

- hydrodynamic lift and drag computation (hull and appendices)
- modelling of thrust forces
- interaction effects between hull, skeg and (steerable) propulsion units
- flow separation effects
- water pile-up effects
- effects of waves and/or swell
- dynamic effects before a steady state is reached (e.g. during initiation and turning manoeuvres) and scaling effects (if any).

3.1.2 A validation report, containing comparisons between simulation results and full scale and/or model test results, is to be presented to the Society.

3.1.3 A clear description of the input and output data is to be provided, along with explanations on how the output data are obtained/calculated by the software.

3.1.4 As a minimum, for each relevant loading condition (see Ch 1, Sec 2, [4.1.1]) the following set of results is to be provided in tabular form as function of the escort speed for the rated values of the steering force $T_{Y,R}$ and the braking force $T_{X,R}$:

- Rated steering force $T_{Y,R}$ or steering force T_Y corresponding to rated braking force $T_{X,R}$, as applicable
- Rated braking force $T_{X,R}$ or braking force T_X corresponding to rated steering force $T_{Y,R}$, as applicable
- Corresponding towline force T_{ESC}
- All corresponding forces acting in transverse direction (hydrodynamic, thrust and towline)
- Corresponding heeling angle
- Corresponding heeling moment
- Corresponding towline angle relative to the escorted ship (refer to α in Ch 1, Sec 1, [2.7.2])
- Corresponding drift angle of the escort tug (refer to β in Ch 1, Sec 1, [2.7.2]).

Note 1: The highest anticipated values of the steering force, braking force, towline force and heeling moment do not normally all occur in the same condition (defined by the position of escort tug relative to the escorted ship and the drift angle), although more than one parameter may have its highest value in a particular condition. Hence it is necessary to consider at least two conditions: one for the highest anticipated steering force and one for the highest anticipated braking force. In case the highest anticipated heeling moment and/or towline force do not occur in either one of these two conditions, the relevant conditions are to be added.

3.1.5 It is recommended that the results of the escort performance simulations are presented in the form of diagrams showing the envelope of the (steady state) combinations of steering and braking forces obtained from the simulations. Such diagrams should cover the applicable escort speed range, with a recommended step of 2 knots.

3.2 Escort performance trials

3.2.1 Escort performance trials at full scale or model scale may be carried out in order to obtain the characteristics of escort tugs defined in Ch 1, Sec 1, [2.7].

3.2.2 The trials are to cover the applicable range of loading conditions and escort speeds.

3.2.3 The following documents are to be submitted for information prior to testing:

- Relevant loading conditions, defined by draught (or displacement) and trim, for which the tug is designed to perform escort services
- Applicable range of test speeds of the escorted ship: the speed is defined as the relative speed with respect to the sea, taking into account current effects
- Main propulsion characteristics, in particular power and maximum orientation angle of the rudder(s) (propellers);
- Preliminary calculation of the rated steering force $T_{Y,R}$, rated braking force $T_{X,R}$ and rated steady towline force $T_{ESC,R}$ as defined in Ch 1, Sec 1, [2.7], as well as the corresponding heeling moments and heeling angles, for the range of test speeds

- Calculation of the route deviation of the escorted ship (for testing purposes the escorted ship is to be selected so that the route deviation induced by the tug is kept reasonably small)
- Preliminary stability calculations for the above mentioned conditions
- Escort towing arrangement plan, including the load cell and specification of the components
- Documentation relevant to the Bollard Pull test, see [2.1.1].

3.2.4 Prior to commencing the escort performance trials the following data are to be recorded:

- Wind speed and direction
- Sea state, including significant wave height and peak period
- Current speed and direction
- Water depth
- Loading condition of the escort tug: draught (or displacement) and trim
- Loading condition of the escorted ship.

3.2.5 Testing is to be performed over the applicable range of towline angles as defined in the escort towing arrangement plan. The length of the towline and the angle of the towline with the horizontal plane are to represent a typical operating condition.

3.2.6 As a minimum, the following data is to be collected during testing for post-processing and analysis:

- Towline force (tension) T_{ESC}
- Towline angle α , as defined in Ch 1, Sec 1, [2.7.2]
- Drift angle β , as defined Ch 1, Sec 1, [2.7.2]
- Heeling angle of the escort tug
- Towline length and angle of towline with the horizontal plane.

3.2.7 It is also recommended to measure the following data:

- Power setting and orientation angle of rudder(s) (propellers) of the escort tug
- Time needed to make the tug swing from the equilibrium position to its mirror position (see Ch 1, Sec 1, Fig 2).

3.2.8 For each combination of loading condition and test speed:

- The rated steering force $T_{Y,R}$ and rated braking force $T_{X,R}$ are to be calculated on the basis of the corresponding measured steady towline force T_{ESC} and the associated measured towline angle, drift angle and the angle between the towline and the horizontal plane.
- The maximum heeling arm is to be calculated on the basis of the corresponding measured steady towline force T_{ESC} as defined in Ch 1, Sec 1, [2.7], the associated measured heeling angle and the GZ curve applicable to the loading condition considered.

Note 1: The GZ curve is to be based on the escort tug in upright position before commencing the escort operation.

3.2.9 As a minimum, for each tested loading condition the following set of results is to be provided in tabular form as function of the escort speed for the rated values of the steering force $T_{Y,R}$ and the braking force $T_{X,R}$:

- Rated steering force $T_{Y,R}$ or steering force T_Y corresponding to rated braking force $T_{X,R}$ as applicable
- Rated braking force $T_{X,R}$ or braking force T_X corresponding to rated steering force $T_{Y,R}$ as applicable
- Corresponding towline force $T_{ESC,R}$
- Corresponding heeling angle
- Corresponding heeling moment
- Corresponding towline angle relative to the escorted ship (refer to α in Ch 1, Sec 1, [2.7.2])
- Corresponding drift angle of the escort tug (refer to β in Ch 1, Sec 1, [2.7.2]).

Note 1: The highest anticipated values of the steering force, braking force, towline force and heeling moment do not normally all occur in the same condition (defined by the position of escort tug relative to the escorted ship and the drift angle), although more than one parameter may have its highest value in a particular condition. Hence it is necessary to consider at least two conditions: one for the highest anticipated steering force and one for the highest anticipated braking force. In case the highest anticipated heeling moment and/or towline force do not occur in either one of these two conditions, the relevant conditions are to be added.

3.2.10 For model testing, due consideration is to be paid to scale effects for establishing the escort tug characteristics at full scale from the model test results.

3.3 Escort equipment testing

3.3.1 Load testing

Escort winches, including the associated emergency release system are normally to be load tested at the DL, as defined in Ch 1, Sec 3, [3.2.2], or the BHL, as defined in Ch 1, Sec 1, [2.4], whichever is the greatest, unless a complete calculation verifying that all the load bearing parts of the winch comply with the requirements in Ch 1, Sec 3, [3.2.3] is submitted to the Society for information and is deemed acceptable.

Generally, load testing is to be conducted at a special facility equipped to generate the required line tension (e.g. maker's premises) and to be witnessed by the Society.

In case an escort winch is of conventional, proven design, for which load testing has been previously performed and deemed acceptable by the Society, it is sufficient to perform on board function testing in accordance with [3.3.2].

Note 1: The Society may request the winch manufacturer to supply records of the load tests performed.

3.3.2 Function testing

In general, the proper functioning of the towing equipment used for escort services is to be verified by on board testing and to be witnessed by the Society. Function testing is to be performed both for normal operating conditions and in accordance with the escort towing arrangement plan as well as in emergency conditions (emergency release, failure of main power supply). The safe operation of the escort winch from all control stations is to be demonstrated.

Escort winches are to be function tested on board.

The correct functioning of the winch brake, the load carrying winch components and the associated supporting structure is to be demonstrated at a towline force equal to the design Bollard Pull, as defined in Ch 1, Sec 1, [2.1].

The emergency release systems are to be function tested according to [2.4].

Winch operating modes to be function tested include hauling in and paying out of the towline, braking and the active pay-out and haul-in system when fitted (see Ch 1, Sec 3, [3.2.3]).

Hydraulic and electrical systems shall be function tested onboard in accordance with the Society's requirements for machinery and electrical systems.

Part E
**Service Notations for
Offshore Service Vessels and Tugs**

Chapter 2

ANCHOR HANDLING VESSELS

- SECTION 1 GENERAL**
- SECTION 2 STABILITY**
- SECTION 3 HULL STRUCTURE**
- SECTION 4 TESTING**

SECTION 1 GENERAL

1 General

1.1 Application

1.1.1 Ships complying with the requirements of this Chapter are eligible for the assignment of the service notation **anchor handling** as defined in Pt A, Ch 1, Sec 2, [4.9.9].

1.1.2 Ships dealt with in this Chapter are to comply with:

- Part A of the Rules
- NR216 Materials and Welding
- applicable requirements according to Tab 1 and specific requirements for testing as defined in Ch 2, Sec 4.

1.2 Definitions

1.2.1 Anchor handling winch

Winch dedicated to anchor handling operations.

1.2.2 Wire

A dedicated line (wire rope, synthetic rope or chain cable) used for the handling of anchors by means of the anchor handling winch.

1.2.3 Stern roller

A roller or similar equipment arranged at the aft boundary of the ship to launch and recover the anchors.

The stern roller is designed to adequately support the working line during the launching/recovering of anchors.

1.2.4 Wire stopper (i.e. shark jaw, karm fork)

Deck equipment designed to temporary secure the inboard end of the working line.

1.2.5 Guide pin

Deck equipment guiding the working lines to the intended sectors

1.2.6 Design bollard pull (BP)

The design bollard pull T_{BP} , in kN, is the maximum sustained towline force the vessel is capable of generating at zero forward speed, as defined in Ch 1, Sec 1, [2.1.1].

1.2.7 Safe working load (SWL)

Load to be specified by the applicant of each shipboard fitting. Individual SWLs are to be marked on each concerned fitting.

1.2.8 Loads on anchor handling winch

- Rated line pull (RP):

Maximum rope tension, in kN, that the winch can haul at the relevant layer, in normal service condition, when the drum rotates at its maximum service speed. The rated line pull is defined for a specific reeled layer which is to be specified by the party applying for classification. The reeled layer may be the first layer (in contact with the drum) or the outer layer.

- Brake holding load (BHL):

Maximum rope tension, in kN, with holding brake activated

- Rendering load (RL):

Maximum rope tension, in kN, at the drum exit when the drum just starts rotating in the opposite direction of the applied driving torque with a first layer of rope wound on the drum.

Table 1 : Applicable requirements

Item		Greater than or equal to 500 GT	Less than 500 GT
Ship arrangement	L ≥ 90 m	• Part B	• NR566
	L < 90 m	• NR600	• NR566
Hull	L ≥ 90 m	• Part B • Ch 2, Sec 3	• Part B • Ch 2, Sec 3
	L < 90 m	• NR600	• NR600
Stability		• Part B • Ch 2, Sec 2	• NR566 • Ch 2, Sec 2
Machinery and cargo systems		• Part C	• NR566
Electrical installations		• Part C	• NR566
Automation		• Part C	• NR566
Fire protection, detection and extinction		• Part C	• NR566
Note 1:			
NR566: Hull Arrangement, Stability and Systems for Ships less than 500 GT			
NR600: Hull Structure and Arrangement for the Classification of Cargo Ships less than 65 m and Non Cargo Ships less than 90 m.			

SECTION 2 STABILITY

1 General

1.1 Operational procedures

1.1.1 Procedures against capsizing

A comprehensive operational plan is to be defined for each anchor handling operation and to be submitted to the Society for information, where at least, but not only, the following procedures and emergency measures should be identified:

- environmental conditions for the operation
- winch operations and movements of weights
- compliance with the stability criteria, for the different expected loading conditions
- permissible tensions on the winches as function of α
- stop work and corrective procedures
- confirmation of the master's duty to take corrective action when necessary.

The arrangement of cargo stowed on deck should be such as to avoid any obstruction of the freeing ports or sudden shift of cargo on deck.

Counter-ballasting to correct the list of the ship during anchor handling operations should be avoided.

1.1.2 Procedures for unintended situations

Procedures for unintended situations are to be established and to be submitted to the Society for information, which describe, for each type of equipment, emergency release methods, time delays and release speed in both normal operating condition and dead ship condition.

These procedures are to be communicated to the ship's crew and vital information are to be displayed next to the control desk or any other appropriate location on the bridge where the navigator on duty may see easily the information from his usual command post.

2 Stability

2.1 General

2.1.1 During anchor handling, the wire comes from the anchor handling winch and is controlled by the guide pins and connected, over the stern roller, to the lifted item (see Fig 1).

2.1.2 For vessels used for anchor handling while their towing capacity and/or the traction power of their winches is/are already in action, calculations are to be made showing the maximum acceptable tension to which the vessel is able to be exposed.

2.2 Assumptions

2.2.1 All loading conditions are to be prepared with 10% and 100% bunkers and all winches fully loaded with the heaviest anticipated line type.

The tension T_W in the wire, its vertical component T_{Wz} and its horizontal component T_{Wy} , as well as the angles α and β defining the wire position are shown in Fig 2.

2.3 Heeling moment

2.3.1 The most unfavourable conditions for transverse tension are to be considered for the calculations.

The maximum heeling moment occurs when α equals 90° . Even though practical experience shows that α normally does not exceed a maximum value of 45° during anchor handling operations, the calculations are to be made up to 90° in order to cover the complete range of angles.

Calculations are to be made for the maximum acceptable wire tension T_W allowing the vessel to fulfill the requirements of [2.4] during anchor handling operations.

The heeling arm b_h is to be calculated, in m, as the total effect of the horizontal and vertical transverse components T_{Wy} and T_{Wz} of wire tension T_W , as follows:

$$b_h = T_W(h \sin \alpha \cos \beta + y \sin \beta) \frac{\cos \theta}{D} = (T_{Wy} \cdot h + T_{Wz} \cdot y) \frac{\cos \theta}{D}$$

where:

h : Torque arm, in m, of the horizontal component T_{Wy}

h is equal to the vertical distance from the centre of the main propulsion propeller or of the stern side propellers, whichever is deeper (see Fig 5), to either:

- the uppermost part of the guide pins
- a point on a line defined between the highest point of the winch pay-out and the top of the stern or any physical restriction of the transverse wire movement.

In case of azimuth thrusters, h is to be measured from the centre of the deepest drive (see Fig 6)

D : Displacement of the considered loading condition, in t, including the vertical component T_{Wz} of the towing force

θ : Angle of heel, in deg.

Figure 1 : Schematic definition of equipment

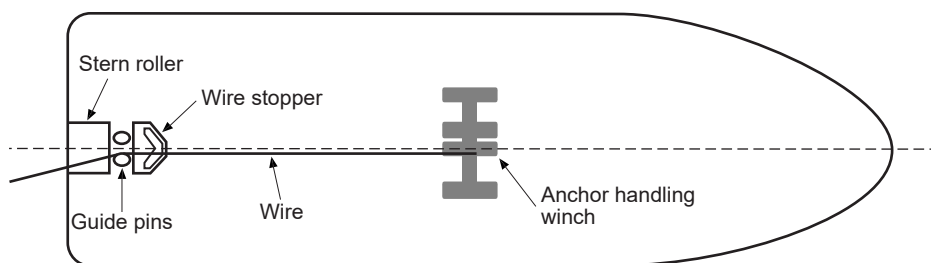
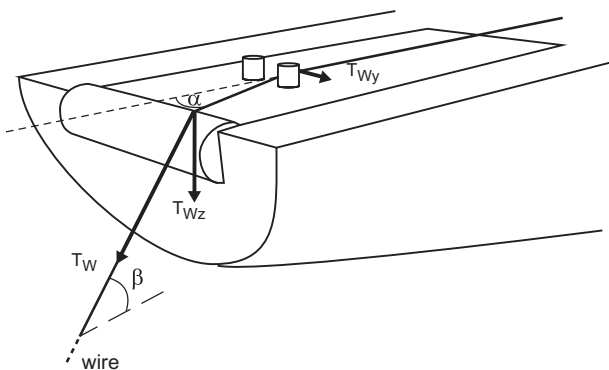

Figure 2 : Tension and position of wire



- T_W : Permissible tension in the wire, in t, which can be applied to the ship as loaded while working through a specified tow pin set, at each α , for which all stability criteria can be met. T_W should in no circumstance be taken as greater than RP or BHL
- T_{Wz} : Vertical component of the wire tension causing the ship to trim: $T_{Wz} = T_W \sin\beta$
- T_{Wy} : Horizontal component of the wire tension causing the ship to heel: $T_{Wy} = T_W \sin\alpha \cos\beta$
- β : Vertical angle, in degrees, between the waterline and the wire, varying between 0 and +90
- α : Horizontal angle, in degrees, between the longitudinal axis passing through the inner part of the guide pin and the wire, the ship being in the upright position, taken positive starboard and varying up to 90°. The angle α does not need to be taken less than:
 - 15° for a vessel having a double pair of guide pins (PS and SB) (see Fig 3), and
 - 25° in the case of a single pair of guide pins located at the vessel centreline (see Fig 4).

Figure 3 : Vessel with single pair of guide pins

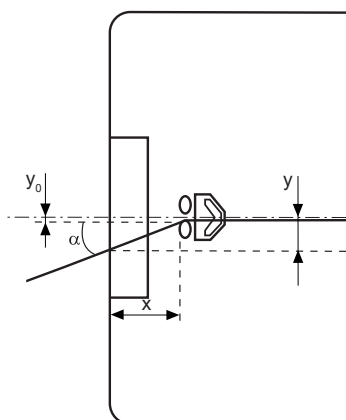
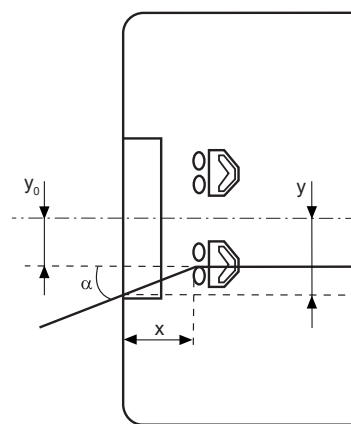

Figure 4 : Vessel with double pair of guide pins



- y_0 : Transverse distance, in m, between the vessel centreline and the inner part of the guide pin or any physical restriction of the transverse wire movement
- x : Longitudinal distance, in m, between the stern and the guide pin or any physical restriction of the transverse wire movement
- y : Torque arm, in m, of the vertical component T_{Wz} .

y is equal to the transverse distance from the vessel centreline to the outboard point at which the wire tension is applied to the ship and is obtained by the formula:

$$y = y_0 + x \tan\alpha$$

y is not to be taken greater than $B/2$ and may be limited to a physical restriction of the transverse wire movement. Cargo rails, cranes, A-frames may be considered as physical restrictions.

2.4 Intact stability

2.4.1 The stability of the vessel, for the loading conditions included in Pt B, Ch 3, App 2, [1.2.11], is to be in compliance with the requirements of Pt B, Ch 3, Sec 2.

For all loading condition intended for anchor handling operations, the vessel is to comply with the following criteria, under the assumptions set out in [2.2]:

- The residual area between the righting lever curve and the heeling arm curve calculated in accordance with [2.3.1] should not be less than 0,070 metre-radians. The area is determined from the first intersection of the two curves to the second intersection or the angle of downflooding, θ_f , whichever is less.

- b) The maximum residual righting lever GZ between the righting lever curve and the heeling arm curve calculated in accordance with [2.3.1] should be at least 0,2 m.
- c) The maximum heeling angle is to be limited to one of the following angles, whichever occurs first (see Fig 7):
 - heeling angle equivalent to GZ value equal to 50% of GZ_{max}
 - angle of deck immersion
 - 15°.
- d) A minimum freeboard at stern, on centreline, of at least 0,005L should be maintained in all operating conditions, with a displacement D, as defined in [2.3.1]. In the case of anchor retrieval operation, a lower minimum freeboard may be accepted provided that due consideration has been given to this in the operation plan.

- e) Loading conditions other than the most unfavourable ones and associated with anchor handling operations need to be calculated in the same way as described in item a), taking into account the prevailing practice with regards to loads on deck and winch reels.

Generally, when calculating the trim and the righting arm curve, the vertical component of the towing force is added as a weight in the loading condition located at the centreline and at the stern of the vessel (normally the stern roller).

Alternatively, in case the vertical and horizontal components of the tension are both included in the loading condition (e.g. by introducing a weight with offset), the righting arm curve is to be corrected as follows before intact stability calculations:

$$GZ = GZ_0 + b_h \cos \theta$$

Figure 5 : Vessel with stern side propellers and a fixed propulsion propeller

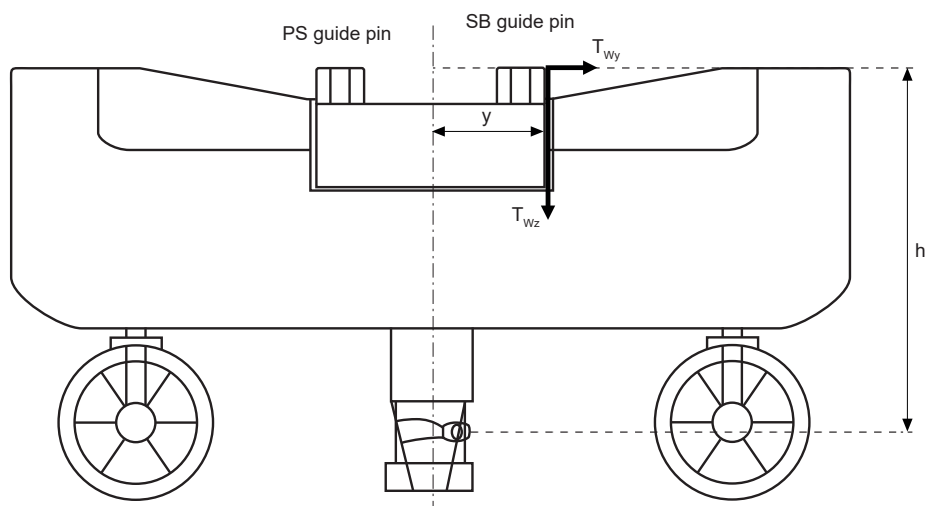

Figure 6 : Vessel with azimuth thrusters and a moveable propulsion propeller

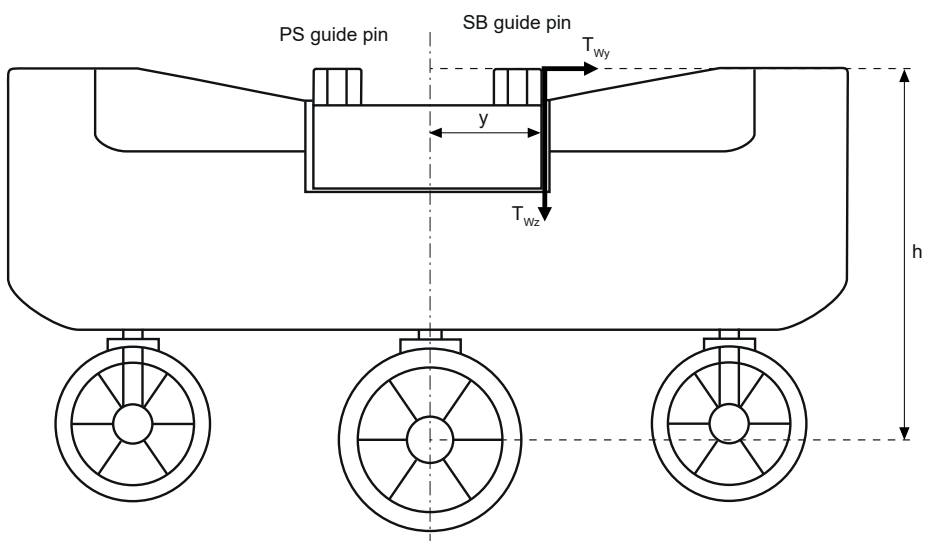
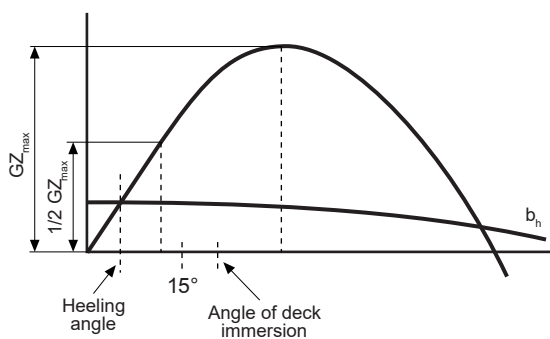

Figure 7 : Heeling and righting arm curves



with:

- GZ : Righting arm curve after correction, so as to exclude the horizontal component of the towing force
- GZ₀ : Righting arm curve including both vertical and horizontal components of the towing force, varying with the heeling angle θ of the vessel.

2.5 Information to be displayed

2.5.1 Information stating the maximum allowed tension in the wire, as well as the corresponding angle α , in accordance with the calculations performed for each loading condition, are to be communicated to the vessel's crew and displayed next to the control desk or at any location where the navigator on duty can easily see the information from his command post.

The displayed information is to be under the form of diagrams, prepared so that the master can easily determine the maximum tension that can be applied to the vessel, as a function of the angle α , for a given value of trim and displacement (or draught), so as to satisfy the stability criteria (see Fig 9).

2.6 Stability booklet

2.6.1 The following information is to be included in the stability booklet in addition to the information required in Pt B, Ch 3, App 2:

- where ballasting or de-ballasting is applied before anchor handling operations, a sufficient number of loading conditions representing this operation is to be submitted, taking into account the relevant free surface effects
- calculation of the maximum heeling moment and corresponding maximum tension is to be provided, for every loading condition intended for anchor handling operations, satisfying the criteria of [2.4].

The interval between two values of angle α is not to exceed 5° when α is less than 50° and 10° when α is from 50° up to 90°.

The results are to be given in tables (see Tab 1 completed by Fig 8) and diagrams (see Fig 9) showing the maximum tension (corresponding to the maximum

acceptable heeling moment) as a function of angle α , provided for the draught (or displacement) and trim values covering the intended anchor handling operations (values before application of the tension).

The maximum permissible tension tables and curves may be omitted from the stability booklet provided one of the two following instrument is installed on board:

- a software checking the intended or actual tension on the basis of the maximum permissible tension curves, or
- a software performing direct stability calculations to check compliance with the criteria given in [2.4], for a given loading condition (before application of the tension force), a given tension and a given wire position (defined by angles α and β , see Fig 2).

Figure 8 : Example of the operational, cautionary and stop work zones illustration

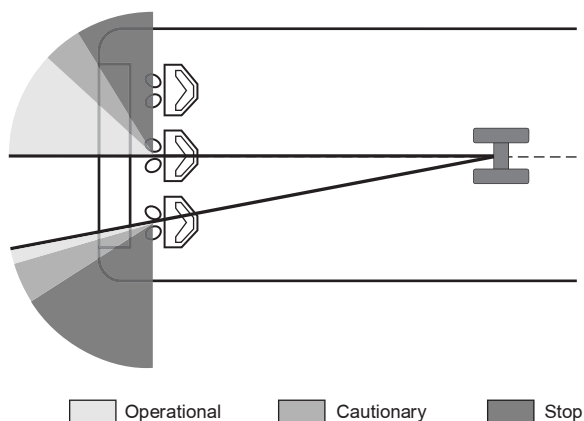

Operational Cautionary Stop

Figure 9 : Example of permissible tension sector diagram

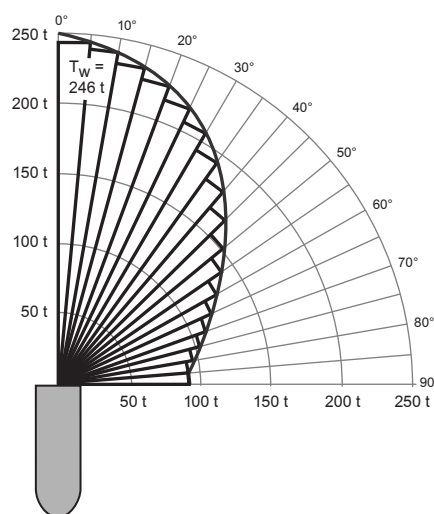

Table 1 : Example of permissible wire tension table

Table of permissible wire tension Tw (in tonnes) (Rated line pull = 600 t; Brake holding load = 700 t)																							
Wire horizontal angle α (deg)																							
Trim (m)	0			10			20			30			45			60			90				
	-0,5	0	0,5	-0,5	0	0,5	-0,5	0	0,5	-0,5	0	0,5	-0,5	0	0,5	-0,5	0	0,5	-0,5	0	0,5		
Wire between the centerline guide pins																							
Draft = 4,8 m	700	700	700	700	700	690	625	580	540	460	460	435	290	290	290	190	190	190	165	165	165	165	
	Operational zone			Operational zone			Operational zone			Operational zone			Operational zone			Cautionary zone			Stop zone			Stop zone	
Draft = 5,8 m	700	700	700	700	700	690	655	600	550	430	485	435	285	285	310	190	180	200	170	165	170	170	
	Operational zone			Operational zone			Operational zone			Operational zone			Operational zone			Cautionary zone			Stop zone			Stop zone	
Draft = 6,8 m	700	635	520	700	635	520	645	575	510	550	485	415	355	355	305	230	240	220	200	205	200	200	
	Operational zone			Operational zone			Operational zone			Operational zone			Operational zone			Cautionary zone			Stop zone			Stop zone	
Wire between the outer guide pins																							
Draft = 4,8 m	545	500	465	480	435	405	385	380	350	300	300	300	215	215	215	170	170	170	165	165	165	165	
	NA			Operational zone			Cautionary zone			Cautionary zone			Stop zone			Stop zone			Stop zone			Stop zone	
Draft = 5,8 m	575	520	465	500	455	405	360	390	350	275	300	300	220	210	240	180	175	190	170	165	170	170	
	NA			Operational zone			Cautionary zone			Cautionary zone			Stop zone			Stop zone			Stop zone			Stop zone	
Draft = 6,8 m	555	480	410	500	435	370	440	385	330	365	340	295	260	270	235	210	215	200	200	205	200	200	
	NA			Operational zone			Cautionary zone			Cautionary zone			Stop zone			Stop zone			Stop zone			Stop zone	
Note 1:																							
<ul style="list-style-type: none"> • Trim is negative by the bow. Interpolate between drafts only. For intermediate trim values, use lower permissible tension. • Table is for planning and monitoring anchor handling operation. Specific loading conditions may be required for each anchor move. • Trim should be minimized or by bow for anchor moves where high wire tensions are expected. • Wire horizontal angle is relative to vessel's centerline. For intermediate angle values, use the higher table value. 																							
Note 2:																							
<ul style="list-style-type: none"> • NA indicates where the angle of tow wire is not geometrically possible (i.e. at centerline in the case of wire going through outer guide pins). Permissible tensions are provided for reference only. • If wire angle falls into the "Cautionary zone" and the wire tension exceeds the permissible value, corrective actions are required. • If wire angle falls into the "Stop zone" and the wire tension exceeds the permissible value, operations are to be stopped and tension in the line is to be reduced. • If planned wire tension exceeds the permissible values of the "Operational zone", additional calculations are required. Operations should not be planned for high angles. 																							
Note 3: Not Vessel loading must be in accordance with the approved stability booklet and include assumed margins.																							

SECTION 3 HULL STRUCTURE

1 Documentation

The listed plans are to be construction plans complete with all the dimensions and are to contain full indication on the type of materials employed.

1.1 Documents to be submitted

1.1.1 In addition to the documentation requested in Part B, the plans and documents listed in Tab 1 are to be submitted as applicable.

Plans of equipment which are type-approved by the Society need not be submitted, provided the types and model numbers are made available.

Table 1 : Documents to be submitted

No.	I / A (1)	Document
1	I	General arrangement showing: <ul style="list-style-type: none"> - detail arrangement of anchor handling deck equipment (wire stopper, guide pins, etc.) - typical arrangement of cargo on deck (anchors, wires, chain cables, etc.) - chain lockers used for mooring deployment - anchor handling/towing winch - tugger winches - stern roller, including lateral limits on both ends - lifting appliances, if any - typical paths of lines between winches and stern roller, showing the limit line sectors
2	I	Design information of deck winches, including: <ul style="list-style-type: none"> - detailed drawing of winches - maximum rated line pull (RP), and the reeled layer for which the rated line pull is defined - brake holding load (BHL), and the reeled layer for which the rated line pull is defined - rendering load (RL) - specification of emergency quick release system including response time and intended remaining holding force after release - strength calculation of the drum with flanges, shafts with coupling, framework and brakes - minimum guaranteed breaking strength of the wire
3	I	Design information of wire stopper, including: <ul style="list-style-type: none"> - safe working load (SWL) - emergency release capabilities in normal and dead ship conditions
4	I	Design information of guide pins, including: <ul style="list-style-type: none"> - safe working load (SWL) - emergency release capabilities in normal and dead ship conditions
5	I	Safe working load (SWL) of stern roller
6	I	Design bollard pull (T_{BP})
7	I	Maximum weight of anchors on deck
8	I	Maximum weight of wire/chain cable stored on deck
9	I	Operational manual, including procedures mentioned in Ch 2, Sec 2, [1.1]
10	A	Detailed drawing of wire stopper
11	A	Detailed drawing of guide pins
12	A	Detailed drawing of stern roller
13	A	Deck reinforcements in way of deck equipment, including foundations and supports
14	I / A	Loading manual, if relevant (see [2.2])
(1)	A : For approval I : For information.	

2 General requirements

2.1 Deck equipment

2.1.1 It is the Designer's responsibility to check the consistency of strength capacity of the deck equipment (stern roller, wire stopper, guide pins) in relation to the performance of the winch.

2.2 Loading manual

2.2.1 For ships greater than 90 m in length, the loading manual is to include a loading condition corresponding to the chain lockers being fully loaded and winches fully loaded with the heaviest anticipated line type.

2.3 Design loads

2.3.1 The design loads DL defined below are to be taken not less than the maximum value of the tension in the wire (or chain cable) during anchor handling resulting from the stability analysis.

Local strength of deck structure is to be based on the following design loads:

- in way of anchor handling winch:
DL = max (1,5 T_{BP}; 1,5 RP; BHL)
- in way of guide pins:
DL = max (2 SWL; 1,5 RP; BHL)
- in way of wire stopper:
DL = max (2 SWL; 1,5 RP; BHL)
- in way of stern roller:
DL = max (2 SWL; 1,5 RP; BHL)

Strength of anchor handling winch is to be based on the two following design loads DL:

- case 1: DL = max (1,5 T_{BP}; 1,5 RP)
- case 2: DL = BHL as defined in Ch 2, Sec 1, [1.2].

Strength of deck equipment (guide pins, wire stopper, stern roller) is to be based on the same design loads as those considered for the deck foundations.

2.4 Deck structure

2.4.1 Local reinforcements are to be provided in way of deck areas subjected to concentrated loads.

The strength checking required in [2.5], [2.6] and [2.7] are to be based on the following criteria:

- Stress level in the deck structure is not to exceed the following permissible stresses:
 - normal stress: $\sigma \leq 0,75 R_y$
 - shear stress: $\tau \leq 0,47 R_y$
 - equivalent stress: $\sigma_{VM} \leq 0,85 R_y$

where:

R_y : Minimum yield stress, in N/mm², of the material, to be taken equal to 235/k unless otherwise specified.

- In case the yielding check of the structure is carried out by means of a three-dimensional finite element model, these permissible stress levels may be increased by 10 per cent.
- Where necessary, buckling strength is to be checked.

Strength of the deck structure is to be checked considering:

- in way of anchor handling winch, including welds: design load DL as defined in [2.3], with the following assumptions:
 - wire considered at the most unfavourable layer of the drum, in general
 - direction of wire cable taken in the most unfavourable direction allowed by the anchor handling equipment.
- in way of anchor handling deck equipment other than winches (i.e. guide pins, wire stopper), including welds: design load DL as defined in [2.3], exerted in the most unfavourable directions, with the most severe vertical location.
- in way of stern roller, including welds: design load DL as defined in [2.3], considering an anchor hanging underwater below the stern roller at a negative angle of 30° with respect to a vertical axis (see Fig 1).
- in way of handling and/or lifting appliances, if any, including welds: the maximum dynamic reactions exerted by lifting appliance pedestal, according to the lifting appliance certification.

Figure 1 : Angle of hanged anchor with respect to vertical axis

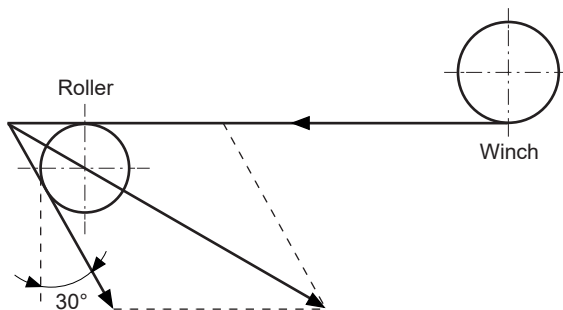

2.5 Anchor handling winch

2.5.1 The combined stress is not to exceed the following permissible stress depending on the design load, for both cases defined in [2.3]:

- for case 1: $\sigma_{VM} \leq R_e$
- for case 2: $\sigma_{VM} \leq 0,9 R_e$

where:

R_e : Minimum specified yield stress of material, in N/mm²

The emergency quick-release system is to be designed to:

- allow drum release in all operational modes, including emergency mode, in the shortest possible delay

- be activated locally at the winch and from a position at the bridge with full view and control of the operation
- operate even in dead ship condition
- be protected against unintentional operation.

A winch intended for functions of anchor handling and towing is to meet both the requirements of Ch 1, Sec 3, [2.7] and the requirements above.

Strength is to be checked on the basis of the calculations submitted, in particular the components which are exposed to the tension in the towline, such as the winch drums, drum shafts, brakes and support frame.

2.6 Anchor handling deck equipment other than winches

2.6.1 Strength of the deck equipment used for anchor handling, including guide pins and wire stopper, is to be checked under the maximum load on the wire equal to design load DL as defined in [2.3], exerted in the most unfavourable directions, with the most severe vertical location.

Stress levels in the deck structure in way of anchor handling deck equipment are not to exceed the following permissible stresses:

- normal stress: $\sigma \leq 0,75 R_e$
- shear stress: $\tau \leq 0,47 R_e$
- equivalent stress: $\sigma_{VM} \leq 0,85 R_e$

In case the yielding check of the structures is carried out by means of a three-dimensional finite element model, these permissible stress levels may be increased by 10 per cent.

Where necessary, buckling strength is to be checked.

2.7 Stern roller

2.7.1 The structure of the stern roller is to be checked under design load DL as defined in [2.3], considering an anchor hanging underwater below the stern roller at a negative angle of 30° with respect to a vertical axis (see Fig 1).

For strength purposes, design load DL as defined in [2.3] is to be considered in any transverse position on the stern roller, as allowed by the actual locations of the guide pins and the anchor handling deck equipment.

The bending, shearing and combined stresses are not to exceed the following permissible stresses:

- normal stress: $\sigma \leq 0,75 R_e$
- shear stress: $\tau \leq 0,47 R_e$
- equivalent stress: $\sigma_{VM} \leq 0,85 R_e$

Where necessary, buckling strength is to be checked.

2.8 Wire

2.8.1 The minimum breaking strength of the wire is not to be less than the design load DL defined in [2.3] for the anchor handling winch.

The towline is to be protected from being damaged by chafing and abrasion. To this end, cargo rails, bulwarks, and all the elements supporting the towline are to be adequately rounded.

Strength of the wire attachment on the winch is to allow breaking in case the line is to be run out. Under normal operation, at least 3 turns of wire on the drum are considered.

SECTION 4

TESTING

1 General

1.1 Load test

1.1.1 Load test is to be performed at the manufacturer workshop, for hoisting operation, and witnessed by the Society.

1.1.2 Winches are to be tested at design load DL, as defined in Ch 2, Sec 3, [2.3]. However, in case the winch is not of novel or particular design, it is sufficient to perform load test at the design bollard pull T_{BP} . In this case, it may be performed on board during commissioning trials and is to be witnessed by the Society.

1.2 Functional test

1.2.1 The tests are performed to check the proper:

- operation of the equipment within the specified limitations

- arrangement of the towline sectors and the towline paths, as shown on the arrangement drawing
- functioning under the normal operation modes
- functioning under the emergency operation modes, including the emergency release and the dead ship operations.

In particular, the emergency quick-release systems are to be function tested at the design bollard pull T_{BP} .

1.3 Operational tests

1.3.1 Prior to anchor handling operation, operational tests are to be performed by the crew in order to ensure the satisfactory operation of the winches and deck equipment, in particular the emergency quick-release system, as requested by the operational manual.

1.3.2 Records of the operational tests are to be kept on board and made available to the Society upon request.

Part E
**Service Notations for
Offshore Service Vessels and Tugs**

Chapter 3
SUPPLY VESSELS

- SECTION 1 GENERAL**
- SECTION 2 GENERAL ARRANGEMENT**
- SECTION 3 STABILITY**
- SECTION 4 HULL STRUCTURE**
- SECTION 5 MACHINERY AND CARGO SYSTEMS**
- SECTION 6 ELECTRICAL INSTALLATIONS, INSTRUMENTATION AND
AUTOMATION**
- SECTION 7 FIRE PREVENTION, PROTECTION AND EXTINCTION**

SECTION 1 GENERAL

1 General

1.1 Application

1.1.1 The present Chapter applies to ships defined as per [1.5.30] and [1.5.41], hereafter referred to as OSV(s).

OSV(s) means:

- well-stimulation vessels, and/or
- ships which are primarily engaged in the transport of stores, materials and equipment, including:
 - oil products with a flashpoint greater than 60°C, and
 - hazardous and noxious liquid substances, to, from and between offshore installations.

Attention is drawn to the Owner that compliance of this Chapter for a ship intended to carry oil product with a flashpoint equal to or less than 60°C is submitted to prior agreement by the Administration considering this ship as an OSV and not as an oil tanker, in particular regarding the statutory regulations dealing with the ship general arrangement.

1.1.2 Carriage of oil products

The requirements of the present Chapter regarding the carriage of oil products are to be in compliance with MARPOL Annex I, Regulation 2.2.

Note 1: When intended to carry less than 200 m³ of non-flammable oil products only, supply vessels need not to comply with the specific requirements for the carriage of oil products.

1.1.3 Carriage of heated cargoes

For OSVs intended to carry cargoes heated at a temperature of 90°C or more, the design of the cargo tanks is subject to special consideration.

1.1.4 Carriage of hazardous and noxious goods in packaged form

The provisions in this Chapter do not regulate the transport of hazardous and noxious goods in packaged form.

1.1.5 Equivalents to the OSV Chemical Code

The IMO OSV Chemical Code chapter 1 paragraph 1.3 may allow equivalents to the provision of the Code. In the scope of the assignment of the additional service feature **HNLS** and/or **WELLSTIM** defined in [1.3], these equivalent provisions are to be transmitted to the Society for review.

1.2 IMO regulations

1.2.1 The requirements of the present Chapter are generally consistent with the following International Maritime Organisation (IMO) regulations:

- OSV Code – Code of safe practice for the carriage of cargoes and persons by offshore supply vessels adopted by IMO Resolution A.863(20), as amended by Resolution MSC 237(82).

- Offshore Supply Vessel Guidelines – Guidelines for the design and construction of offshore supply vessels adopted by IMO Resolution A.469(XII), as amended by Resolutions MSC 235(82) and MSC 335(90).
- IBC Code – IMO International Code for the Construction and Equipment of Ships carrying Dangerous Chemicals in Bulk, as amended.
- OSV Chemical Code – IMO OSV Chemical Code for the transport and handling of hazardous and noxious liquid substances in bulk on Offshore Support Vessels adopted by IMO Resolution A.1122(30).

1.2.2 The present Chapter does not cover Chapter 13 and Chapter 15 of the OSV Chemical Code (with the exception of sections 15.5.4 and 15.5.5) which are outside the scope of classification.

1.3 Classification notations

1.3.1 Service notation supply

Ships complying with the requirements of this Chapter are eligible for the assignment of the service notation **supply**, as defined in Pt A, Ch 1, Sec 2, [4.9.11].

Where applicable, the service notation **supply** is to be completed by the additional service feature **HNLS** (as defined in [1.3.2]) and/or **WELLSTIM** (as defined in [1.3.3])

1.3.2 Additional service feature HNLS

Ships granted with the service notation **supply** and intended to carry the following products:

- products which are listed in chapters 17 or 18 of the IBC Code and the latest edition of the MEPC.2/Circular (Provisional categorization of liquid substances in accordance with MARPOL Annex II and the IBC Code) and their related references to chapters 15 and 19; and/or
- oil-based/water-based mud containing mixtures of products listed in chapters 17 and 18 of the IBC Code and the MEPC.2/Circular; and/or
- liquid carbon dioxide (high purity and reclaimed quality) and liquid nitrogen; and/or
- contaminated backloads (see [1.5.4]),

are to be assigned with the additional service feature **HNLS** completed, where applicable, by:

one or several of the following notations subject to the products listed hereabove are considered:

- FP≤60°C** when the ship may carry products with a flash point equal to or less than 60°C.
- toxic** when the ship may carry toxic products (see [1.5.39])
- acids** when the ship may carry acids (see [1.5.1])
- LG** when the ship may carry liquid carbon dioxide and/or liquid nitrogen

1.3.3 Additional service feature WELLSTIM

The additional service feature **WELLSTIM** may be assigned to ships granted with the service notation **supply** when intended to carry products used in a blending (see [1.5.5]) or production process dedicated to the search and exploitation of seabed mineral resources, this process being installed on-board to facilitate such operations.

Where applicable, the additional service feature **WELLSTIM** is to be completed by one or several of the following notations: **-FP≤60°C**, **-toxic**, **-acids** and **-LG** as defined in [1.3.2].

1.4 Applicable rules

1.4.1 Ships dealt with in this Chapter are to comply with:

- Part A of the Rules
- NR216 Materials and Welding
- applicable requirements according to Tab 1.

1.5 Definitions

1.5.1 Acids

Products are deemed to be acids when in Chapter 17 of IBC Code, or the latest edition of the MEPC.2/Circ., paragraph 15.11 is assigned in column o.

1.5.2 Accommodation spaces

Accommodation spaces are those spaces used for public spaces, corridors, lavatories, cabins, offices, hospitals, cinemas, games and hobbies rooms, barber shops, pantries containing no cooking appliances and similar spaces.

1.5.3 Administration

Administration means the Government of the State whose flag the vessel is entitled to fly.

1.5.4 Backload

Backload means contaminated bulk liquids, taken on board a vessel offshore, for transport either back to shore or to alternate offshore site.

1.5.5 Blending additives

Blending additives means small amounts of liquid substances used during blending of products or production processes of cargoes for use in the search and exploitation of seabed mineral resources on board vessels used to facilitate such operations.

Table 1 : Applicable requirements

Item		Greater than or equal to 500 GT	Less than 500 GT
Ship arrangement	L ≥ 65 or 90 m (1)	<ul style="list-style-type: none"> • Part B • Ch 3, Sec 2 	<ul style="list-style-type: none"> • NR566 (2) • Ch 3, Sec 2
	L < 65 or 90 m (1)	<ul style="list-style-type: none"> • NR600 • Ch 3, Sec 2 	<ul style="list-style-type: none"> • NR566 (2) • Ch 3, Sec 2
Hull	L ≥ 65 or 90 m (1)	<ul style="list-style-type: none"> • Part B • Ch 3, Sec 4 	<ul style="list-style-type: none"> • Part B • Ch 3, Sec 4
	L < 65 or 90 m (1)	<ul style="list-style-type: none"> • NR600 • Ch 3, Sec 4 	<ul style="list-style-type: none"> • NR600 • Ch 3, Sec 4
Stability		<ul style="list-style-type: none"> • Part B • Ch 3, Sec 3 	<ul style="list-style-type: none"> • Part B • Ch 3, Sec 3
Machinery and cargo systems		<ul style="list-style-type: none"> • Part C • Ch 3, Sec 5 	<ul style="list-style-type: none"> • NR566 (2) • Ch 3, Sec 5
Electrical installations and automation		<ul style="list-style-type: none"> • Part C • Ch 3, Sec 6 	<ul style="list-style-type: none"> • NR566 (2) • Ch 3, Sec 6
Fire protection, detection and extinction		<ul style="list-style-type: none"> • Part C • Ch 3, Sec 7 	<ul style="list-style-type: none"> • NR566 (2) • Ch 3, Sec 7
<p>(1) Refer to the scope of application of NR600.</p> <p>(2) For ships granted with HNLS and/or WELLSTIM service features, the limit of 500 GT does not apply for the specific requirements associated to these service features</p> <p>Note 1: NR566: Hull Arrangement, Stability and Systems for Ships less than 500 GT. NR600: Hull Structure and Arrangement for the Classification of Cargo Ships less than 65 m and Non Cargo Ships less than 90 m.</p> <p>Note 2: For ships granted with HNLS and/or WELLSTIM service features, in case of conflict, requirements mentioned in this Chapter shall prevail</p>			

1.5.6 Cargo area

Cargo area is that part of the offshore support vessel where:

- a) a pollution hazard only substance having a flashpoint exceeding 60°C and not defined as toxic, is likely to be present and includes cargo tanks, portable tanks used as deck cargo tanks, slop tanks, cargo pump-rooms, pump-rooms adjacent to cargo tanks and enclosed spaces in which pipes containing cargoes are located. Areas on open deck are not considered part of the cargo area.
- b) a safety hazard substance having a flashpoint exceeding 60°C and not defined as a toxic, is likely to be present and includes cargo tanks, portable tanks used as deck cargo tanks, slop tanks, cargo pump-rooms, pump-rooms adjacent to cargo tanks, hold spaces in which independent tanks are located, cofferdams surrounding integral tanks, enclosed spaces in which pipes containing cargoes are located and the following deck areas:
 - 1) within 3 m of cargo tank installed on deck or portable tanks used as deck cargo tanks;
 - 2) areas on open deck, or semi-enclosed spaces on deck, within 3 m of any cargo tank access outlet;
 - 3) areas on open deck over an integral tank without an overlaying cofferdam plus the open deck area extending transversely and longitudinally for a distance of 3 m beyond each side of the tank;
 - 4) areas on open deck, or semi-enclosed spaces on deck, within 3 m of cargo manifold valve, cargo valve, cargo pipe flange, except spaces within the 3 m zone that are separated by an enclosed bulkhead to the minimum height as given in item 6);
 - 5) areas on open deck, or semi-enclosed spaces on open deck above and in the vicinity of any cargo tank vent outlet intended for the passage of large volumes of vapour mixture during cargo loading, within a vertical cylinder of unlimited height and 3 m radius upon the centre of the outlet, and within a hemisphere of 3 m radius below the outlet;
 - 6) areas on the open deck within spillage coamings surrounding cargo manifold valves and 3 m beyond these, up to a height of 2.4 m above the deck; and
 - 7) compartments for cargo hoses.
- c) a substance having a flashpoint not exceeding 60°C, or defined as toxic or vapours of such cargo, is likely to be present and includes cargo tanks, portable tanks used as deck cargo tanks, slop tanks, cargo pump-rooms, pump-rooms adjacent to cargo tanks, hold spaces in which independent tanks are located, cofferdams surrounding integral tanks, enclosed spaces in which pipes containing cargoes are located and the following deck areas:
 - 1) within 3 m of cargo tank installed on deck or portable tanks used as deck cargo tanks;
 - 2) areas on open deck, or semi-enclosed spaces on deck, within 4.5 m of gas or vapour outlet, cargo manifold valve, cargo valve, cargo pipe flange, cargo pump-room ventilation outlets and cargo tank

openings for pressure release provided to permit the flow of small volumes of gas or vapour mixtures caused by thermal variation;

- 3) areas on open deck, or semi-enclosed spaces on open deck above and in the vicinity of any cargo gas outlet intended for the passage of large volumes of gas or vapour mixture during cargo loading, within a vertical cylinder of unlimited height and 10 m radius centred upon the centre of the outlet, and within a hemisphere of 10 m radius below the outlet;
- 4) areas on open deck, or semi-enclosed spaces on deck, within 3m of cargo pump-room entrances, cargo pump-room ventilation inlet, openings into cofferdams;
- 5) areas on the open deck within spillage coamings surrounding cargo manifold valves and 3 m beyond these, up to a height of 2.4m above the deck;
- 6) compartments for cargo hoses; and
- 7) within the hose landing area.

1.5.7 Cargo control station

Cargo control station means a location that is manned during cargo transfer operations for the purpose of directing or controlling the loading or unloading of cargo.

1.5.8 Cargo pump-room

Cargo pump-room is a space containing pumps and their accessories for the handling of the products.

1.5.9 Cargo tank

Cargo tank is the envelope designed to contain the cargo.

1.5.10 Cofferdam

Cofferdam is the isolating space between two adjacent steel bulkheads or decks. This space may be a void space or a ballast space.

1.5.11 Control stations

Control stations are those spaces in which vessels' radio or main navigating equipment or the emergency source of power is located or where the fire-recording or fire-control equipment is centralized. This does not include special fire-control equipment which can be most practically located in the cargo area.

1.5.12 Dangerous goods

Dangerous goods mean the substances, materials and articles covered by the IMDG Code.

IMDG Code means the International Maritime Dangerous Goods Code (resolution MSC.122(75), as amended)

1.5.13 Deck spread

Deck spread means portable tanks, piping, equipment, processing equipment and control stations secured to the vessel by permanent means and used in the operation of the vessel.

1.5.14 Density

Density is the ratio of the mass to the volume of a product, expressed in terms of kilograms per cubic metre. This applies to liquids, gases and vapours.

1.5.15 Flammable liquid

A flammable liquid is any liquid having a flashpoint (closed cup test) not exceeding 60°C determined by an approved flashpoint apparatus.

Note 1: A liquid heated within 15°C of its flashpoint is also considered as a flammable liquid.

1.5.16 Flashpoint

Flashpoint is the temperature in degrees Celsius at which a product will give off enough flammable vapour to be ignited. Values given in the Chapter are those for a "closed cup test" determined by an approved flashpoint apparatus.

1.5.17 Fuel oil

Fuel oil means any oil used as fuel in connection with the propulsion and auxiliary machinery of the ship on which such oil is carried.

1.5.18 Gravity tank

Gravity tank means a tank having a design pressure not greater than 0,07 MPa gauge at the top of the tank. A gravity tank may be independent or integral. A gravity tank should be constructed and tested according to recognized standards, taking account of the temperature of carriage and relative density of the cargo.

1.5.19 Gas-safe area

Gas-safe area is an area which is not defined as hazardous.

1.5.20 Hazardous area

Hazardous area is an area in which an explosive atmosphere is or may be expected to be present in quantities such as to require special precautions for the construction, installation and use of electrical apparatus.

1.5.21 Hold space

Hold space is the space enclosed by the vessels' structure in which an independent cargo tank is situated.

1.5.22 Hose landing area

Hose landing area means an area on the main deck, except those in compartments for cargo hoses, where cargo hoses of substances having a flashpoint not exceeding 60°C and/or defined as toxic are located during cargo transfer.

1.5.23 Independent

Independent means that a piping or venting system, for example, is in no way connected to another system and that there are no provisions available for the potential connection to other systems.

1.5.24 Independent tank

Independent tank means a cargo containment envelope which is not contiguous with, or part of, the hull structure.

An independent tank is built and installed so as to eliminate whenever possible (or in any event to minimize) its stressing as a result of stressing or motion of the adjacent hull structure. An independent tank is not essential to the structural completeness of the ship's hull.

1.5.25 Integral tank

Integral tank means a cargo containment envelope which forms part of the ship's hull and which may be stressed in

the same manner and by the same loads which stress the contiguous hull structure and which is normally essential to the structural completeness of the ship's hull.

1.5.26 IGC Code

International Gas Carrier Code (IGC Code) means the International Code for the Construction and Equipment of Ships Carrying Liquefied Gases in Bulk (resolution MSC.5(48), as amended).

1.5.27 MARPOL

MARPOL means the International Convention for the Prevention of Pollution from Ships, 1973, as modified by the Protocol of 1978 relating thereto, as amended.

1.5.28 Noxious liquid substance

Noxious liquid substance means any substance indicated in the Pollution Category column of chapter 17 or 18 of the International Bulk Chemical Code, or the current MEPC.2/Circular or provisionally assessed under the requirements of regulation 6.3 of MARPOL Annex II as falling into categories X, Y or Z.

1.5.29 Offshore portable tank

Offshore portable tank means a portable tank specially designed for repeated use for transport of dangerous goods to, from and between offshore facilities. An offshore portable tank is designed and constructed in accordance with the Guidelines for the approval of containers handled in open seas (MSC/Circ.860)

1.5.30 Offshore support vessels

Offshore support vessels (OSVs) are:

- a) multi-mission vessels which are primarily engaged in the transport of stores, materials and equipment to and from mobile offshore drilling units, fixed and floating platforms and other similar offshore installations; or
- b) multi-mission vessels, including well-stimulation vessels, but excluding mobile offshore drilling units, derrick barges, pipe-laying barges and floating accommodation units, which are otherwise primarily engaged in supporting the work of offshore installations.

1.5.31 Oil product

Oil product means petroleum in any form including crude oil, sludge, oil refuse and refined products (other than the petrochemicals which are subject to the provisions of Annex II of MARPOL 73/78, as amended) and excludes fuel oil as defined in [1.5.17].

1.5.32 Open deck

Open deck is defined as an open or semi-enclosed space on cargo deck or inside of the cargo rail. Semi-enclosed spaces are those spaces that either:

- a) are open at two ends; or
- b) have an opening at one end, and are provided with adequate natural ventilation effective over their entire length through permanent openings distributed in the side plating or deckhead or from above, the openings having a total area of at least 10% of the total area of the space sides.

1.5.33 Pollution hazard only substance

Pollution hazard only substance means a substance having an entry only of "P" in column d in chapter 17 of the IBC Code.

1.5.34 Portable tank

Portable tank means a multimodal tank used for the transport of dangerous goods.

1.5.35 Pump-room

Pump-room is a space, located in the cargo area, containing pumps and their accessories for the handling of ballast and oil fuel.

1.5.36 Safety hazard substance

Safety hazard substance means a substance having an entry of "S" or "S/P" in column d in chapter 17 of the International Bulk Chemical Code.

1.5.37 Separate

Separate means that a cargo piping system or cargo vent system, for example, is not connected to another cargo piping or cargo vent system.

The separation may be achieved by the use of design or operational methods. Operational methods are not to be used within a cargo tank and are to consist of one of the following types:

- removing of spool pieces or valves and blanking of pipe ends
- arrangement of two spectacle flanges in series, with provisions of detecting leakage into the pipe between the two spectacle flanges.

1.5.38 SOLAS

SOLAS means the International Convention for the Safety of Life at Sea, 1974, as amended.

1.5.39 Toxic products

Products are deemed to be toxic when in Chapter 17 of IBC Code, or the latest edition of the MEPC.2/Circ., paragraph 15.12 is assigned in column o.

1.5.40 Void space

Void space is an enclosed space in the cargo area external to a cargo tank, other than a hold space, ballast space, oil fuel tank, cargo pump-room, pump-room, or any space in normal use by personnel.

1.5.41 Well-stimulation vessel

Well-stimulation vessel means an offshore support vessel with specialized equipment and industrial personnel that deliver products and services directly into a well-head.

2 Documents to be submitted**2.1 General**

2.1.1 The documents listed in Tab 2 are to be provided in addition to the documents listed in the applicable rules specified in [1.4].

Table 2 : Documents to be submitted

No.	Documents to be submitted	I/A (1)
Hull		
1.1	General arrangement	I
1.2	Access arrangement	A
1.3	Arrangement of entrances, air inlets and openings to accommodation service, machinery spaces and control stations	A
1.4	Capacity plan with clear indications of: <ul style="list-style-type: none"> • cargo tanks with nature and density of cargoes and indicating whether the product is flammable • fuel oil tanks • cofferdams adjacent to cargo tanks 	I
1.5	Stowage of deck cargoes and lashing arrangement with location of lashing points and indication of design load	I
1.6	Connection of the cargo tanks with the hull structure	A
1.7	Structural reinforcements in way of load transmitting elements, such as winches, rollers, lifting appliances	A
Machinery		
2.1	Diagram of cargo piping system	A
2.2	Diagram of cargo tank venting system	A
2.3	Diagram of the cargo tank level gauging with overfill safety arrangement	A
2.4	Diagram of the bilge and ballast system serving spaces within the cargo area	A
2.5	Diagram of the bilge and ballast system serving spaces outside the cargo area	A
(1)	A: For approval; I: For information.	
(2)	Diagrams are also to include, where applicable, the (local and remote) control and monitoring systems and automation systems.	

No.	Documents to be submitted	I/A (1)
2.6	General layout of the cargo pump room with details of: <ul style="list-style-type: none"> • Bulkhead penetrations • Flammable vapours detections system • Bilge level monitoring devices • Ventilation. 	A
2.7	Diagram of the cargo heating system, if any	A
2.8	Diagram of inert gas system with details of the inert gas plant, if any	A
2.9	Diagram showing deck tank arrangements: <ul style="list-style-type: none"> • portable tank information and details • sea fastening arrangement and calculations • deck arrangement and pipeline drawings • material safety data sheets of carried products 	I A A I
Electrical installations (2)		
3.1	Plan of hazardous area including location of all electrical equipment	A
3.2	Document giving details of types of cables and safety characteristics of the electrical equipment installed in hazardous area	A
Fire safety		
4.1	Fire extinguishing system in cargo area	A
4.2	Specification of fixed means of vapour detection	A
<p>(1) A: For approval; I: For information.</p> <p>(2) Diagrams are also to include, where applicable, the (local and remote) control and monitoring systems and automation systems.</p>		

SECTION 2

GENERAL ARRANGEMENT

1 Compartment arrangement

1.1 General

1.1.1 Watertight integrity

The machinery spaces and other working and living spaces in the hull should be separated from the other compartments by watertight bulkheads.

1.1.2 Afterpeak bulkhead

An afterpeak bulkhead should be fitted and made watertight up to the freeboard deck. The afterpeak bulkhead may, however, be stepped below the freeboard deck, provided the degree of safety of the supply vessel as regards subdivision is not thereby diminished.

1.1.3 Location of cargo tanks

All cargo tanks are to be located aft of the collision bulkhead and forward of the aft peak.

1.2 Additional requirements for ships granted with HNLS and/or WELLSTIM additional service features

1.2.1 With reference to OSV Chemical Code Chapter 2, section 2.1.5, the following requirements are, in particular, to be complied with:

a) Double bottoms:

Requirements mentioned in Pt B, Ch 2, Sec 2, [3], excluding Pt B, Ch 2, Sec 2, [3.1.7], are to be referred to.

b) Collision bulkhead:

Requirements mentioned in Pt B, Ch 2, Sec 1, [3] are to be referred to.

c) After peak, machinery space and stern tubes:

Requirements mentioned in Pt B, Ch 2, Sec 1, [4] are to be referred to.

d) Height of transverse watertight bulkheads other than collision bulkhead and after peak bulkhead:

Requirements mentioned in Pt B, Ch 2, Sec 1, [5] are to be referred to.

e) Openings in watertight bulkheads and internal decks:

Requirements mentioned in Pt B, Ch 2, Sec 1, [6.2] and Pt B, Ch 2, Sec 1, [6.3] are to be referred to.

f) Openings in the shell plating below the bulkhead deck:

Requirements mentioned in:

- Pt B, Ch 8, Sec 10, [2], Pt B, Ch 8, Sec 10, [3] and Pt B, Ch 8, Sec 10, [4], and
- Pt C, Ch 1, Sec 10, [8]

are to be referred to, taking into account Ch 3, Sec 5, [1.5.1].

1.2.2 Location of cargo tanks

Requirements mentioned in OSV Chemical Code Chapter 2, section 2.9.1 are to be referred to.

1.2.3 Cargo segregation

Requirements mentioned in OSV Chemical Code Chapter 3, section 3.1.1, 3.1.2.1, 3.1.2.2, 3.1.6 and 3.1.7 are to be referred to.

1.2.4 Accommodation, service space and control stations

Requirements mentioned in OSV Chemical Code Chapter 3, section 3.2 are to be referred to.

1.3 Compartment arrangement in way of oil product cargo tanks

1.3.1 Ships carrying oil products with a flashpoint more than 60°C

A cargo tank carrying exclusively oil products having a flashpoint exceeding 60°C (closed cup test) are to be segregated from accommodation spaces, drinking water and stores for human consumption by means of a cofferdam, void space, cargo pump-room, fuel oil tank, or other similar space. On-deck stowage of independent tanks or installation of independent tanks in otherwise empty hold spaces is to be considered as satisfactory.

1.3.2 Length of cargo tanks

The length of each cargo tank shall not exceed 10 metres or one of the values of Tab 1, as applicable, whichever is the greater.

Note 1: When the aggregate capacity of oil tanks is less than 200 m³, this requirements might not be applied.

1.3.3 Slop tanks

Requirements mentioned in Pt D, Ch 7, Sec 2, [3.5.1] and Pt D, Ch 7, Sec 2, [3.6] are to be applied.

Note 1: When aggregate capacity of oil tanks does not exceed 1000 m³, these requirements might not be applied.

Table 1 : Length of cargo tanks

Longitudinal bulkhead	Type of cargo tank	b_i/B (1)	Centreline bulkhead	Length (m)
No bulkhead	-	-	-	$(0,5 b_i/B + 0,1) L$ (2)
Centreline bulkhead	-	-	-	$(0,25 b_i/B + 0,15) L$
Two or more bulkheads	Wing cargo tank	-	-	0,2 L
	Centre cargo tank	if $b_i/B > 1/5$	-	0,2 L
		if $b_i/B < 1/5$	No	$(0,5 b_i/B + 0,1) L$
			Yes	$(0,25 b_i/B + 0,15) L$
(1) Where b_i is the minimum distance from the side of the supply vessel to the outer longitudinal bulkhead of the tank in question measured inboard at right angles to the centreline at the level corresponding to the assigned summer freeboard.				
(2) Not to exceed 0,2 L.				

2 Arrangement and access to spaces

2.1 Access arrangement in way of cargo tanks for oil products

2.1.1 Direct access from open deck

Supply vessels are to be provided with the following:

- Access to cargo tanks is to be direct from the open deck and such as to ensure their complete inspection except for access to cargo tanks in double-bottoms that may be through a cargo pump-room, pump-room, deep cofferdam, pipe tunnel or similar dry compartments, provided that the ventilation of these spaces complies with Ch 3, Sec 5, [6.1.1].
- Access to cargo pumps does not need to be from the open deck provided that the access is independent of watertight doors.

2.1.2 Dimension of access openings

The following requirements are applicable for all the spaces referred to in [2.1.1]:

- For access through horizontal openings, hatches or manholes, the dimensions are to be sufficient to allow a person wearing a self-contained air-breathing apparatus and protective equipment to ascend or descend any ladder without obstruction and also to provide a clear opening to facilitate the hoisting of an injured person from the bottom of the space. The minimum clear opening is no to be less than 600 mm by 600 mm.
- For access through vertical openings, or manholes providing passage through the length and breadth of the space, the minimum clear opening is not to be less than 600 mm by 800 mm at a height of not more than 600 mm from the bottom shell plating unless gratings or other footholds are provided.
- Smaller dimensions may be approved by the Society in special circumstances, if the ability to traverse such openings or to remove an injured person can be proved to the satisfaction of the Society.

2.2 Additional requirements for ships granted with HNLS and/or WELLSTIM additional service features

2.2.1 Access to spaces in the cargo area

Requirements mentioned in OSV Chemical Code Chapter 3, section 3.3 are to be referred to.

2.2.2 Additional requirements for ships granted with notations -FP \leq 60°C or -acids or -toxic

In addition to the requirements mentioned in [2.2.1], the following apply:

- For cargo tanks segregation, requirements mentioned in OSV Chemical Code Chapter 4, sections 4.1.2 and 4.1.3, are to be referred to.
- For the location of openings into accommodation, passageways, service and machinery spaces and control stations in relation to cargo piping and cargo vent systems, requirements mentioned in OSV Chemical Code Chapter 4, section 4.1.7 are to be referred to.
- For access to cargo tanks, cofferdams, void spaces, cargo pump-room, pump-room, empty tank, or other spaces adjacent to cargo tanks, requirements mentioned in OSV Chemical Code Chapter 4, section 4.1.8 are to be referred to.
- High walkways should not be located within the cargo area. Requirements mentioned in OSV Chemical Code Chapter 4, section 4.1.9 are to be referred to.

2.2.3 Additional requirements for ships granted with notation -FP \leq 60°C

In addition to the requirements mentioned in [2.2.1] and [2.2.2], for location of entrances, openings into accommodation, service and machinery spaces and control stations, requirements mentioned in OSV Chemical Code Chapter 4, section 4.2.2 are to be referred to.

2.2.4 Additional requirements for ships granted with notation -acids

In addition to the requirements mentioned in [2.2.1] and [2.2.2], the special requirements mentioned in the IBC Code Chapter 15, section 15.11 are to be referred to.

2.2.5 Additional requirements for ships granted with notation -toxic

In addition to the requirements mentioned in [2.2.1] and [2.2.2], the following apply:

- a) The special requirements mentioned in the IBC Code Chapter 15, section 15.12 are to be referred to.
- b) For location of entrances, openings into accommodation, passageways, service and machinery spaces and control stations, requirements mentioned in OSV Chemical Code Chapter 4, sections 4.3.2, 4.3.3, 4.3.4, 4.3.5 and 4.3.6, are to be referred to.
- c) For marking of cargo deck areas, requirements mentioned in OSV Chemical Code Chapter 15, section 15.5.5 are to be referred to.

3 Arrangement for hull and forecastle openings

3.1 General

3.1.1 Sidescuttles and windows

Sidescuttles and windows of opening type are, in general, accepted only in unexposed areas of the deckhouses located immediately above the forecastle and the areas above.

3.1.2 Sidescuttles of gas-safe areas facing hazardous areas

Sidescuttles of gas-safe areas facing hazardous areas, excluding those of non-opening type, are to be capable of ensuring an efficient gas-tight closure.

Warning plates are to be fitted on access doors to accommodation and service spaces facing the cargo area indicating that the doors and sidescuttles mentioned above are to be kept closed during cargo handling operations.

3.1.3 Freeing ports

The area of freeing ports is to be increased by 50% with respect to that determined according to Pt B, Ch 8, Sec 10, [6] or NR566, as applicable.

For ships operating in areas where icing is likely to occur, shutters may not be fitted.

3.1.4 Freeing ports through box-bulwarks

Where box-bulwarks the upper level of which extends to the forecastle deck are fitted in way of the loading area, the freeing ports are to pass through these box-bulwarks and their area is to be increased to take account of the height of the bulwarks.

SECTION 3 STABILITY

1 General

1.1 Application

1.1.1 Every decked OSV of 24 metres and over is to comply with the provisions of present Section.

Note 1: The requirements of this Section are based on IMO Off-shore Supply Vessel Guidelines amended by MSC 335(90).

1.1.2 The intact and damage stability of an OSV of less than 24 metres in length should be to the satisfaction of the Society.

1.2 Relaxation

1.2.1 Unless specified in [1.3], relaxation in the requirements of the present Section may be permitted by the Society for ships granted with navigation notation **coastal area**, provided the operating conditions are such as to render compliance with these requirements unreasonable or unnecessary.

1.3 Additional requirements for ships granted with HNLS and/or WELLSTIM additional service features

1.3.1 No relaxation in the requirements of the present Section shall be accepted for ships assigned with the additional service features **HNLS** and/or **WELLSTIM**.

1.3.2 In addition to the requirements mentioned in this Section, the provisions of OSV Chemical Code Chapter 2, section 2.1, are to be applied.

Note 1: With reference to OSV Chemical Code Chapter 2, section 2.1.2, the stability of ships other than those carrying cargoes containing mixtures and individual products indicated in chapter 17 of the IBC Code and the latest edition of the MEPC.2/Circular will be subject to special consideration.

2 Intact stability

2.1 General

2.1.1 General stability criteria

The intact stability for the loading conditions defined in Pt B, Ch 3, App 2, [1.2.1] and Pt B, Ch 3, App 2, [1.2.12] with the assumptions in [2.1.5], is to be in compliance with the requirements of Pt B, Ch 3, Sec 2, [2.1] or, as an alternative, with the requirements of [2.1.2]. The additional criteria of [2.1.3] are also to be complied with.

2.1.2 Alternative stability criteria

The following equivalent criteria are recommended where the ship's characteristics render compliance with Pt B, Ch 3, Sec 2, [2.1] impracticable:

- the area, in $m \cdot rad$, under the curve of righting levers (GZ curve) may not be less than 0,070 up to an angle of 15° when the maximum righting lever (GZ) occurs at 15° and 0,055 up to an angle of 30° when the maximum righting lever (GZ) occurs at 30° or above. Where the maximum righting lever (GZ) occurs at angles of between 15° and 30° , the corresponding area "A", in $m \cdot rad$, under the righting lever curve is to be:

$$A = 0,055 + 0,001 \cdot (30^\circ - \theta_{max})$$

where θ_{max} is the angle of heel, in degrees, at which the righting lever curve reaches its maximum

- the area, in $m \cdot rad$, under the righting lever curve (GZ curve) between the angles of heel of 30° and 40° , or between 30° and θ_i if this angle is less than 40° , may not be less than 0,03, where θ_i is defined in Pt B, Ch 3, Sec 2, [2.1.2]
- the righting lever (GZ), in m , is to be at least 0,20 at an angle of heel equal to or greater than 30°
- the maximum righting lever (GZ) is to occur at an angle of heel not less than 15°
- the initial transverse metacentric height (GM), in m , may not be less than 0,15 m .

2.1.3 Additional criteria

A minimum freeboard at the stern of at least 0,005 L is to be maintained in all operating conditions.

2.1.4 Factors of influence

The stability criteria mentioned in [2.1.1] and [2.1.2] are minimum values; no maximum values are recommended. It is advisable to avoid excessive values, since these might lead to acceleration forces which could be prejudicial to the vessel, its complement, its equipment and the safe carriage of cargo.

Where anti-rolling devices are installed, the stability criteria indicated in [2.1.1] and [2.1.2] are to be maintained when the devices are in operation.

2.1.5 Assumptions for calculating loading conditions

If a vessel is fitted with cargo tanks, the fully loaded conditions of Pt B, Ch 3, App 2, [1.2.12] are to be modified, assuming first the cargo tanks full and then the cargo tanks empty.

If in any loading condition water ballast is necessary, additional diagrams are to be calculated, taking into account the water ballast, the quantity and disposition of which are to be stated in the stability information.

In all cases when deck cargo is carried, a realistic stowage weight is to be assumed and stated in the stability information, including the height of the cargo and its centre of gravity.

Where pipes are carried on deck, a quantity of trapped water equal to a certain percentage of the net volume of the pipe deck cargoes is to be assumed in and around the pipes. The net volume is to be taken as the internal volume of the pipes, plus the volume between the pipes. This percentage is 30 if the freeboard amidships is equal to or less than $0,015 L$ and 10 if the freeboard amidships is equal to or greater than $0,03 L$. For intermediate values of the freeboard amidships, the percentage may be obtained by linear interpolation. In assessing the quantity of trapped water, the Society may take into account positive or negative sheer aft, actual trim and area of operation.

If a vessel operates in zones where ice accretion is likely to occur, allowance for icing should be made in accordance with the provisions of Pt B, Ch 3, Sec 2, [6].

A vessel, when engaged in towing operations, may not carry deck cargo, except that a limited amount, properly secured, which would neither endanger the safe working of the crew nor impede the proper functioning of the towing equipment, may be accepted.

2.2 Additional requirements for ships granted with HNLS and/or WELLSTIM additional service features

2.2.1 Requirements mentioned in the OSV Chemical Code Chapter 2, section 2.2, are to be referred to. In any case, requirements mentioned in the OSV Chemical Code shall prevail.

3 Damage stability

3.1 Damage stability when the additional class notation SDS is assigned

3.1.1 General

Taking into account, as initial conditions before flooding, the standard loading conditions as referred to in Pt B, Ch 3, App 2, [1.2.1] and Pt B, Ch 3, App 2, [1.2.12], the vessel is to comply with the damage stability criteria as specified in [3.1.8].

3.1.2 Damage dimensions

The assumed extent of damage of supply vessels is to be as indicated in Tab 1.

The extent of damage is to occur anywhere in the vessel's length between any transverse watertight bulkhead.

3.1.3 Consideration of transverse watertight bulkheads for flooding

For a vessel with length (L) less than 80 m, a transverse watertight bulkhead extending from the vessel's side to a distance inboard of 760 mm or more at the level of the summer load line joining longitudinal watertight bulkheads may be considered as a transverse watertight bulkhead for the purpose of the damage calculations.

For a vessel with length (L) from 80 m to 100 m, a transverse watertight bulkhead extending from the vessel's side to a distance inboard of $B/20$ or more (but not less than 760 mm) at the level of the summer load line joining longitudinal watertight bulkheads may be considered as a transverse watertight bulkhead for the purpose of the damage calculations.

Where a transverse watertight bulkhead is located within the transverse extent of assumed damage and is stepped in way of a double bottom or side tank by more than 3,05 m, the double bottom or side tank adjacent to the stepped portion of the bulkhead is to be considered as flooded simultaneously.

If the distance between adjacent transverse watertight bulkheads or the distance between the transverse planes passing through the nearest stepped portions of the bulkheads is less than the longitudinal extent of damage given in [3.1.2], only one of these bulkheads should be regarded as effective for the purpose of the damage assumptions described in Tab 1.

Table 1 : Extent of damage

Ship length	Longitudinal extent	Transverse extent (1)	Vertical extent (2)
$L \geq 80$ m	$1/3 L^{2/3}$	$B/20$, or 760 mm (3)	Full depth
$43 < L < 80$ m	$3L/100 + 3$	760 mm	
$L \leq 43$ m	$L/10$		
(1) Measured inboard from the side of the vessel perpendicularly to the centreline at the level of the summer load waterline. (2) From the underside of the cargo deck, or the continuation thereof. (3) Whichever is the greater.			

3.1.4 Progressive flooding

If pipes, ducts or tunnels are situated within the assumed extent of damage, arrangements are to be made to ensure that progressive flooding cannot thereby extend to compartments other than those assumed to be floodable for each case of damage. The progressive flooding is to be considered in accordance with Pt B, Ch 3, Sec 3, [3.3].

3.1.5 Minor damage

If damage of a lesser extent than that specified in [3.1.2] results in a more severe condition, such lesser extent is to be assumed.

3.1.6 Permeability

The permeability of spaces assumed to be damaged is to be as indicated in Tab 2.

Table 2 : Values of permeability

Spaces	Permeability
Appropriated for stores	0,60
Occupied by accommodation	0,95
(1) The permeability of tanks is to be consistent with the amount of liquid carried.	

Spaces	Permeability
Occupied by machinery	0,85
Void spaces, empty tanks	0,95
Intended for dry cargo	0,95
Intended for liquids	(1)
(1) The permeability of tanks is to be consistent with the amount of liquid carried.	

3.1.7 Survival requirements

Compliance with the requirements of [3.1.8] is to be confirmed by calculations which take into consideration the design characteristics of the vessel, the arrangements, configuration and permeability of the damaged compartments and the distribution, specific gravities and free surface effect of liquids.

3.1.8 Damage stability criteria

- a) The final waterline, taking into account sinkage, heel and trim, is to be below the lower edge of any opening through which progressive flooding may take place. The progressive flooding is to be considered in accordance with Pt B, Ch 3, Sec 3, [3.3].
- b) In the final stage of flooding, the angle of heel due to unsymmetrical flooding may not exceed 15°. This angle may be increased up to 17° if no deck immersion occurs.
- c) The stability in the final stage of flooding is to be investigated and may be regarded as sufficient if the righting lever curve has at least a range of 20° beyond the position of equilibrium in association with a maximum residual righting lever of at least 100 mm within this range.

Unprotected openings may not become immersed at an angle of heel within the prescribed minimum range of residual stability unless the space in question has been included as a floodable space in calculations for damage stability. Within this range, immersion of any of the openings referred to in item a) and any other openings capable of being closed weathertight may be authorized.

Note 1: "other openings capable of being closed weathertight" do not include ventilators that have to remain open to supply air to the engine room or emergency generator room for the effective operation of the ship.

- d) The stability is to be sufficient during intermediate stages of flooding. In this regard, the Society applies the same criteria relevant to the final stage of flooding also during the intermediate stages of flooding.

3.1.9 Additional requirements for ships granted with HNLS and/or WELLSTIM additional service features

Requirements mentioned in the OSV Chemical Code sections 2.4, 2.5, 2.6, 2.7 and 2.8. are to be referred to. In any case, requirements mentioned in the OSV Chemical Code shall prevail.

Requirements mentioned in section 2.9.2 of the OSV Chemical Code are to be applied regarding the protrusion of suction wells installed inside cargo tanks for IBC Code ship types 2 and 3 products when affected compartments are determined flooded after a damage

For the application of these requirements, Tab 3 is to be used to consider together:

- ship type according to the quantity of products carried
- damage assumptions
- standard of damage.

Table 3 : Damage stability assumptions for ships granted with HNLS and/or WELLSTIM additional service features

Quantity of product carried, with reference to IBC Code		Ship length	Stability
type 1	type 2 + type 3		
≤ 150 m ³	< 800 m ³	> 100 m	<ul style="list-style-type: none"> • should be assumed to sustain damage described in section 2.6.2 of the OSV Chemical Code anywhere along the length between transverse watertight bulkheads, and • should also comply with SOLAS regulations II-1/6 to II-1/7-3 (probabilistic damage stability standard for a cargo ship).
		≤ 100 m	should be assumed to sustain damage described in section 2.6.2 of the OSV Chemical Code anywhere along the length between transverse watertight bulkheads.
≤ 150 m ³	≥ 800 m ³ and ≤ 1200 m ³	> 100 m	<ul style="list-style-type: none"> • should be assumed to sustain damage described in section 2.6.2 of the OSV Chemical Code anywhere along the length, and • should also comply with SOLAS regulations II-1/6 to II-1/7-3 (probabilistic damage stability standard for a cargo ship).
		≤ 100 m	should be assumed to sustain damage described in section 2.6.2 of the OSV Chemical Code anywhere along the length.
≤ 150 m ³	> 1200 m ³	> 100 m	should be assumed to sustain damage described in section 2.6.1 of the OSV Chemical Code anywhere along the length.
		≤ 100 m	should be assumed to sustain damage described in section 2.6.1 of the OSV Chemical Code anywhere along the length except involving bulkheads bounding a machinery space of category A.
> 150 m ³	any quantity	any length	should be assumed to sustain damage described in section 2.6.1 of the OSV Chemical Code anywhere along the length.

SECTION 4 HULL STRUCTURE

Symbols

- k : Material factor for steel, defined in Pt B, Ch 4, Sec 1, [2.3]
 s : Length, in m, of the shorter side of the plate panel.

1 Structure design principles

1.1 General

1.1.1 For ships greater than 24 m in length, it is recommended that a double skin is provided to reinforce the protection of the main compartments in the event of contact with pontoons or platform piles.

1.2 Side structure exposed to bumping

1.2.1 Longitudinally framed side

In the whole area where the side of the ship is exposed to bumping, distribution frames are to be provided at mid-span, consisting of an intercostal web of the same height as the ordinary stiffeners, with a continuous face plate.

Within reinforced areas, scallop welding for all side ordinary stiffeners is forbidden.

1.2.2 Transversely framed side

In the whole area where the side of the ship is exposed to bumping, a distribution stringer is to be fitted at mid-span, consisting of an intercostal web of the same height as the ordinary stiffeners, with a continuous face plate.

Side frames are to be fitted with brackets at ends.

Within reinforced areas, scallop welding for all side ordinary stiffeners is forbidden.

1.2.3 Fenders

Efficient fenders, adequately supported by structural members, are to be fitted on the side, including the forecastle, on the full length of the areas exposed to contact.

1.3 Deck structure

1.3.1 Local reinforcements are to be fitted in way of specific areas which are subject to concentrated loads.

1.3.2 Exposed decks carrying heavy cargoes or pipes are to provide protection and means of fastening for the cargo, e.g. inside bulwarks, guide members, lashing points, etc.

1.4 Structure of cement tanks and mud compartments

1.4.1 Cargo tanks and hoppers intended to carry mud or cement are to be supported by structures which distribute

the acting forces as evenly as possible on several primary supporting members.

1.5 Additional requirements for ships granted with HNLS and/or WELLSTIM additional service features

1.5.1 Suction wells installed inside cargo tanks

When considering the size of suction wells installed inside the cargo tank, requirements of the OSV Chemical Code, Chapter 2, section 2.9.2 are to be referred to.

1.5.2 Portable tanks used as deck tanks

- Requirements mentioned in OSV Chemical Code Chapter 5, section 5.2.2 are to be referred to regarding the allowable designs of these tanks.
- Requirements mentioned in OSV Chemical Code Chapter 17, section 17.4.2 are to be referred to regarding the securing of the portable tanks to the deck.

1.6 Additional requirements for ships granted with notation -acids

1.6.1 In addition to the requirements mentioned in [1.5], the following apply:

- The requirements in section 15.11 of the IBC Code are to be applied.
- For acid spill protection, requirements mentioned in OSV Chemical Code Chapter 4, sections 4.4.2 and 4.4.6 are to be referred to.

2 Design loads

2.1 Dry uniform cargoes

2.1.1 Still water and inertial pressures

The still water and inertial pressures transmitted to the structure of the upper deck intended to carry loads are to be obtained, in kN/m², as specified in Pt B, Ch 5, Sec 6, [4], where the value of p_s is to be taken not less than 24 kN/m².

3 Hull scantlings

3.1 Plating

3.1.1 Minimum net thickness

The net thickness of the side and upper deck plating is to be not less than the values given in Tab 1.

Table 1 : Minimum net thickness of the side and upper deck plating

Plating	Minimum net thickness, in mm
Side below freeboard deck	The greater of: <ul style="list-style-type: none"> • $2,1 + 0,031 L k^{0,5} + 4,5 s$ • $8 k^{0,5}$
Side between freeboard deck and strength deck	The greater of: <ul style="list-style-type: none"> • $2,1 + 0,013 L k^{0,5} + 4,5 s$ • $8 k^{0,5}$
Upper deck	7,0

3.1.2 Strength deck plating

Within the cargo area, the thickness of strength deck plating is to be increased by 1,5 mm with respect to that determined according to Pt B, Ch 7, Sec 1.

However, the above increase in thickness by 1,5 mm may be omitted provided all the following conditions are fulfilled:

- Wooden planking provide an efficient protection of the deck at the satisfaction of the society.
- The welding of the steel fittings securing the wood protection is performed before coating application.
- Full coating application is applied after item b) above.

3.2 Ordinary stiffeners

3.2.1 Longitudinally framed side exposed to bumping

In the whole area where the side of the supply vessel is exposed to bumping, the section modulus of ordinary stiffeners is to be increased by 15% with respect to that determined according to Pt B, Ch 7, Sec 2.

3.2.2 Transversely framed side exposed to bumping

In the whole area where the side of the supply vessel is exposed to bumping, the section modulus of ordinary stiffeners, i.e. side, 'tweendeck and superstructure frames, is to be increased by 25% with respect to that determined according to Pt B, Ch 7, Sec 2.

3.3 Primary supporting members

3.3.1 Distribution stringers

The section modulus of the distribution stringer required in [1.2.2] is to be at least twice that calculated in [3.2.2] for ordinary stiffeners.

3.3.2 Cement tanks and mud compartments

The net scantlings of the primary supporting members of cement tanks and mud compartments are to be calculated taking into account high stresses resulting from vertical and horizontal accelerations due to rolling and pitching.

Secondary moments due to the tendency of materials to tip over are to be considered by the Society on a case-by-case basis.

4 Other structure

4.1 Aft part

4.1.1 Rollers

At the transom, local reinforcements are to be fitted in way of rollers and other special equipment intended for cargo handling.

4.1.2 Structures in way of rollers

The structures in way of the stern rollers and those of the adjacent deck are considered by the Society on a case-by-case basis, taking into account the relevant loads which are to be specified by the Designer.

4.1.3 Propeller protection

It is recommended that devices should be fitted to protect the propellers from submerged cables.

4.2 Superstructures and deckhouses

4.2.1 Forecastle

The forecastle length may not exceed 0,3 to 0,4 times the length L.

4.2.2 Deckhouses

Due to their location at the forward end of the supply vessel, deckhouses are to be reduced to essentials and special care is to be taken so that their scantlings and connections are sufficient to support wave loads.

4.2.3 Minimum net thicknesses

The net thickness of forecastle aft end plating and of plating of deckhouses located on the forecastle deck is to be not less than the values given in Tab 2.

Table 2 : Plating of forecastle aft end and of deckhouses located on the forecastle deck

Structure	Plating	Minimum net thickness, in mm
Forecastle	aft end	1,04 (5 + 0,01 L)
Deckhouses located on the forecastle deck	front	1,44 (4 + 0,01 L)
	sides	1,31 (4 + 0,01 L)
	aft end	1,22 (4 + 0,01 L)

4.2.4 Ordinary stiffeners

The net section modulus of ordinary stiffeners of the forecastle aft end and of deckhouses located on the forecastle deck is to be not less than the values obtained from Tab 3.

Ordinary stiffeners of the front of deckhouses located on the forecastle deck are to be fitted with brackets at their ends. Those of side and aft end bulkheads of deckhouses located on the forecastle deck are to be welded to decks at their ends.

Table 3 : Ordinary stiffeners of forecastle aft end and of deckhouses located on the forecastle deck

Structure	Ordinary stiffeners on	Net section modulus, in cm ³
Forecastle	aft end plating	3 times the value calculated according to Pt B, Ch 8, Sec 4, [4]
Deckhouses located on the forecastle deck	front plating	
	sides plating	0,75 times that of the forecastle 'tweendeck frames
	aft end plating	

4.3 Structure of cargo tanks

4.3.1 Scantling of cargo tanks is to be in compliance with the provisions of Pt B, Ch 5, Sec 6 and Part B, Chapter 7.

Refer to Ch 3, Sec 5, [3] to Ch 3, Sec 5, [6] for design details.

5 Hull outfitting

5.1 Rudders

5.1.1 Rudder stock scantlings

The rudder stock diameter is to be increased by 5% with respect to that determined according to Pt B, Ch 9, Sec 1, [4].

5.2 Bulwarks

5.2.1 Plating

In the case of a high bulwark, fitted with a face plate of large cross-sectional area, which contributes to the longitudinal strength, the thickness of the plating contributing to the longitudinal strength is to be not less than the value obtained according to Pt B, Ch 7, Sec 1.

5.2.2 Stays

The bulwark stays are to be strongly built with an attachment to the deck reinforced to take account of accidental shifting of deck cargo (e.g. pipes).

5.3 Equipment

5.3.1 Mooring lines

The mooring lines are given as a guidance, but are not required as a condition of classification.

The length of mooring lines may be calculated according to Pt B, Ch 9, App 2, [2].

However, in the case of OSVs provided with devices enabling ample manoeuvring characteristics (e.g. supply vessels provided with two or more propellers, athwartship thrust propellers, etc.), the length of mooring lines, in m, may be reduced to $(L + 20)$.

5.3.2 Chain locker

Chain lockers are to be arranged as gas-safe areas. Hull penetrations for chain cables and mooring lines are to be arranged outside the hazardous areas specified in Ch 3, Sec 1, [1.5.20].

SECTION 5

MACHINERY AND CARGO SYSTEMS

1 Machinery systems

1.1 Cargo heating systems

1.1.1 Where provided, any cargo tank heating system is to comply with the provisions of Pt D, Ch 7, Sec 4, [2.6]

With reference to Ch 3, Sec 1, [1.5.15], particular attention to be provided to the maximum heating temperature of cargo tanks intended for the carriage of oil products.

1.2 Exhaust pipes

1.2.1 Exhaust outlets from diesel engines are to be provided with spark arresters.

1.3 Inert gas system

1.3.1 Where provided, nitrogen/inert gas systems fitted on the ship are to comply with the provision of Pt D, Ch 8, Sec 9, [2].

1.4 Other machinery systems

1.4.1 Fuel oil, lubricating oil tanks, foam forming liquid tanks, oil dispersant tanks and similar tanks which are located inside the cargo area may be served by pumps located outside the cargo area, provided that the piping is directly connected to the associated pump and does not run through cargo tanks.

1.5 Additional requirements for ships granted with HNLS and/or WELLSTIM additional service features

1.5.1 Non cargo discharges below the freeboard deck

Requirements mentioned in Pt C, Ch 1, Sec 10, [8] and OSV Chemical Code section 2.3 are to be referred.

1.5.2 Pumps, ballast lines and vent lines serving ballast tanks

Requirements mentioned in OSV Chemical Code, Chapter 3, section 3.1.5 are to be referred to.

1.6 Additional requirements for ships granted with notations -FP \leq 60°C and/or -acids and/or -toxic

1.6.1 In addition to the requirements mentioned in [1.5], the following apply:

- a) For discharge and filling arrangements for ballast or fresh water sited immediately adjacent to cargo tanks certified for products or residues of products, requirements mentioned in OSV Chemical Code Chapter 4, section 4.1.5 are to be referred to.

- b) For bilge pumping systems serving spaces where cargoes or residues of cargoes may occur, requirements mentioned in OSV Chemical Code Chapter 4, section 4.1.6 are to be referred to.

- c) For air intakes and openings into accommodation, passageways, service and machinery spaces and control stations in relation to cargo piping and cargo vent systems, requirements mentioned in OSV Chemical Code Chapter 4, section 4.1.7 are to be referred to.

1.7 Additional requirements for ships granted with notation -FP \leq 60°C

1.7.1 In addition to the requirements mentioned in [1.5] and [1.6], for air inlets and openings to accommodation, service and machinery spaces and control stations, requirements mentioned in OSV Chemical Code Chapter 4, section 4.2.2 are to be referred to.

1.8 Additional requirements for ships granted with notation -toxic

1.8.1 In addition to the requirements mentioned in [1.5] and [1.6], the following apply:

- a) The special requirements mentioned in the IBC Code Chapter 15, section 15.12 are to be referred to.
- b) For air inlets and openings to accommodation, service and machinery spaces and control stations, requirements mentioned in OSV Chemical Code Chapter 4, sections 4.3.2, 4.3.3 and 4.3.4 are to be referred to.

1.9 Additional requirements for ships granted with notation -acids

1.9.1 In addition to the requirements mentioned in [1.5] and [1.6], the following apply:

- a) For detection of leakage of cargo in adjacent spaces, requirements mentioned in IBC Code Chapter 15, section 15.11.7 are to be referred to.
- b) For cargo pump room bilge pumping and drainage, requirements mentioned in IBC Code Chapter 15, section 15.11.8 are to be referred to.

2 Cargo piping design

2.1 Cargo separation

2.1.1 For cargo handling, a pumping and piping system independent from the other pumping and piping systems on board is to be provided.

2.1.2 The piping system serving the non-flammable oil product cargo tanks may be connected to the fuel oil pumping system in engine room, provided that:

- there are suitable means of separation between the branches serving the tanks dedicated for the cargo oil product tanks and the branches serving the fuel oil tanks
- mixing the two different kinds of oils does not jeopardize the intended use of neither the fuel oil nor the cargo.

2.2 Design and materials

2.2.1 Unless otherwise specified, materials for construction of tanks, piping, fittings and pumps are to be in accordance with Pt D, Ch 7, Sec 4, [3.3.2].

2.2.2 Unless otherwise specified, cargo piping is to be designed and constructed according to Pt D, Ch 7, Sec 4, [3.3.1].

2.3 Piping arrangement

2.3.1 The following requirements apply:

- a) Cargo piping conveying non-flammable oil products, need not be located entirely within the cargo area provided that the separation requirements for accommodation spaces, drinking water and stores for human consumption are observed.
- b) *Control of discharge of oil products is to comply with Pt D, Ch 7, Sec 4, [5.3].*

Note 1: This requirement might not be applied when aggregate capacity does not exceed 1000 m³.

2.4 Additional requirements for ships granted with HNLS and/or WELLSTIM additional service features

2.4.1 Segregation of cargo

Requirements mentioned in OSV Chemical Code Chapter 3, sections 3.1.2.2, 3.1.3 and 3.1.4, are to be referred to.

2.4.2 Piping scantling, fabrication, joining details, flange connections and testing

Requirements mentioned in OSV Chemical Code Chapter 6, sections 6.1, 6.2, 6.3 and 6.4, are to be referred to.

2.4.3 Piping arrangements

Requirements mentioned in OSV Chemical Code Chapter 6, section 6.5, are to be referred to.

2.4.4 Cargo transfer control system

Requirements mentioned in OSV Chemical Code Chapter 6, section 6.6, are to be referred to.

2.4.5 Ship's cargo hoses

Requirements mentioned in OSV Chemical Code Chapter 6, section 6.7, are to be referred to.

2.4.6 Mechanical ventilation in the cargo area

Requirements mentioned in the OSV Chemical Code Chapter 10 are to be referred to.

Note 1: Attention is drawn on the specific requirements to be applied as mentioned in the OSV Chemical Code sections 10.1.1, 10.1.2 and 10.1.3.

Note 2: Attention is drawn on the specific requirements to be applied mentioned in the OSV Chemical Code Chapter 10, section 10.3 for spaces normally not entered.

2.4.7 Pollution prevention - no discharge to the sea

Requirements mentioned in the OSV Chemical Code Chapter 12, section 12.2 are to be referred to.

2.5 Additional requirements for ships granted with notations -FP≤60°C and/or -acids and/or -toxic

2.5.1 In addition to the requirements mentioned in [2.4], for cargo piping location, requirements mentioned in OSV Chemical Code Chapter 4, section 4.1.4 are to be referred to.

3 Cargo tanks

3.1 Cargo oil tanks

3.1.1 Integral and independent gravity tanks are to be constructed and tested according to recognised standards taking into account the carriage temperature and the cargo relative density.

3.2 Additional requirements for ships granted with HNLS and/or WELLSTIM additional service features

3.2.1 Tank type requirements for individual products

Requirements mentioned in OSV Chemical Code Chapter 5, section 5.2.1 are to be referred to.

3.2.2 Carriage of contaminated backloads

Requirements mentioned in OSV Chemical Code Chapter 16, section 16.4.2.1 are to be referred to.

4 Cargo pumping system

4.1 General

4.1.1 The delivery side of cargo pumps is to be fitted with relief valves discharging back to the suction side of the pumps (bypass) in closed circuit. Such relief valves may be omitted in the case of centrifugal pumps with a maximum delivery pressure not exceeding the design pressure of the piping, with the delivery valve closed.

4.1.2 Cargo pumps are to be monitored as required in Tab 1.

Table 1 : Monitoring of cargo pumps

Equipment - parameter	Alarm	Indication	Comments
Pump - discharge pressure	L	Local	<ul style="list-style-type: none"> on the pump (1), or next to the unloading control station
Pump casing - temperature (2)	H		visual and audible, in cargo control room or pump control station
Bearings - temperature (2)	H		visual and audible, in cargo control room or pump control station
Bulkhead shaft gland - temperature (2)	H		visual and audible, in cargo control room or pump control station
(1) And next to the driving machine if located in a separate compartment.			
(2) Not required for supply vessels intended to carry pollution hazard only substances having a flashpoint above 60°C or oil products having a flashpoint above 60°C only.			

5 Cargo tank fittings

5.1 Level gauging systems and overflow control

5.1.1 Cargo oil tanks

For the cargo tanks intended to carry oil products having a flashpoint above 60°C, the gauging systems may be of the open type provided that the relevant provisions of Pt C, Ch 1, Sec 10, [9] and Pt C, Ch 1 Sec 10, [11] are complied with.

Each cargo tank is to be fitted with a level gauging system in compliance with Pt D, Ch 7, Sec 4, [4.4] and an overflow control system in compliance with Pt D, Ch 7, Sec 4, [4.5].

5.2 Cargo tank venting systems

5.2.1 General

Cargo tanks are to be provided with a venting system appropriate to the cargo being carried and these systems shall be independent of the air pipes and venting systems of all other compartments of the ship.

5.2.2 Cargo oil tanks

The following requirements apply:

- general provisions of Pt C, Ch 1, Sec 10, [9] and Pt C, Ch 1, Sec 10, [11] are to be complied with
- tank venting systems are to open to the atmosphere at a height of at least 760 mm above the weather deck
- tanks may be fitted with venting systems of the open type provided with a flame screen.

5.3 Additional requirements for ships granted with HNLS and/or WELLSTIM additional service features

5.3.1 Separated venting systems

Requirements mentioned in OSV Chemical Code Chapter 3, section 3.1.2.3] are to be referred to.

5.3.2 Cargo tank venting

Requirements mentioned in OSV Chemical Code Chapter 7, are to be referred to.

5.3.3 Venting of tanks carrying contaminated backloads

Requirements mentioned in OSV Chemical Code Chapter 16, section 16.4.2.2.1 are to be referred to.

5.3.4 Cargo tank indicators and overflow control

Requirements mentioned in OSV Chemical Code Chapter 11, sections 11.1, 11.2 and 11.3 are to be referred to.

5.4 Additional requirements for ships granted with notation -toxic

5.4.1 In addition to the requirements mentioned in [5.3], the following apply:

- Special requirements in the section 15.12 of the IBC Code Chapter 15 apply.
- For set point of the pressure vacuum valves, requirements mentioned in OSV Chemical Code Chapter 4, section 4.3.7 are to be referred to.
- For alarms for pressure indication at cargo control station and cargo area, requirements mentioned in OSV Chemical Code Chapter 15, section 15.4.4 are to be referred to.

5.5 Additional requirements for ships granted with notation -acids

5.5.1 In addition to the requirements mentioned in [5.3], the following apply:

- For spray shields, requirements mentioned in OSV Chemical Code Chapter 4, section 4.4.3 are to be referred to.
- For loading manifolds (portable shield covers and drainage arrangements), requirements mentioned in OSV Chemical Code, section 4.4.4 are to be referred to.
- For drainage arrangements, requirements mentioned in OSV Chemical Code section 4.4.5 are to be referred to.

6 Mechanical ventilation in the cargo area

6.1 Cargo pump-room ventilation

6.1.1 Ships carrying oil products

- a) Cargo pump rooms are to be mechanically ventilated. The number of changes of air is to be at least 20 per hour, based upon the gross volume of the space.
- b) Ventilation intakes are to be so arranged as to minimize the possibility of recycling hazardous vapours from ventilation discharge openings.
- c) Ventilation ducts are not to be led through gas-safe spaces, cargo tanks or slop tanks.

6.2 Additional requirements for ships granted with HNLS and/or WELLSTIM additional service features

6.2.1 Mechanical ventilation in the cargo area

Requirements mentioned in the OSV Chemical Code Chapter 10 are to be referred to.

Note 1: Attention is drawn on the specific requirements to be applied mentioned in the OSV Chemical Code, sections 10.1.1, 10.1.2 and 10.1.3.

Note 2: Attention is drawn on the specific requirements to be applied mentioned in the OSV Chemical Code Chapter 10, section 10.3 for spaces normally not entered.

7 Discharging and loading of portable tanks on board

7.1 Ships granted with additional service features HNLS and/or WELLSTIM

7.1.1 Type of tank and quantity limitations

Requirements mentioned in the OSV Chemical Code Chapter 17, section 17.2 are to be referred to.

Note 1: When the product transported is not included in the list of products in Ch 3, Sec 1, [1.3.2], attention is drawn on requirements in OSV Chemical Code Chapter 17, section 17.2.2: carriage of such product is to be accepted by the Society and the quantity of such product able to be carried is limited.

7.1.2 Arrangement of deck spread

Requirements mentioned in the OSV Chemical Code Chapter 17, section 17.3 are to be referred to.

Arrangement of the deck spread are to be submitted, referring to the OSV Chemical Code Appendix 3, sections 4.1, 4.2 and attachments 3, 4, 5 and 6.

7.1.3 Portable tanks used as deck tanks

Requirements mentioned in the OSV Chemical Code Chapter 17, sections 17.4.4 and 17.4.6 are to be referred to.

8 Additional requirements for carriage of liquid carbon dioxide and liquid nitrogen

8.1 Ships granted with notation -LG

8.1.1 General

The provisions of this Article does not consider the carriage of other liquefied gases listed in chapter 19 of the IGC Code. When carriage of such liquefied gases are considered, this is to be handled on a case by case basis, referring to the OSV Chemical Code Chapter 18, section 18.12.

The Society may allow adjustments to specific requirements in the IGC Code regarding the cargo containment, materials of construction, vent system for cargo containment and cargo transfer, taking into account existing industry standards and practices, if it is as least as effective as that required by the IGC Code. In any case, these adjustments, if any, are to be submitted to the Administration.

8.1.2 Location of cargo tanks and ship survivability

Requirements mentioned in the OSV Chemical Code Chapter 18, section 18.1.4 are to be referred to.

8.1.3 Carriage requirements

Requirements mentioned in the OSV Chemical Code Chapter 18, section 18.1.5 are to be referred to.

8.1.4 Accommodation, service and machinery spaces and control stations

Requirements mentioned in the OSV Chemical Code Chapter 18, section 18.2 are to be referred to.

8.1.5 Cargo containment

Requirements mentioned in the OSV Chemical Code Chapter 18, section 18.3 are to be referred to.

Note 1: Attention is drawn to the specific requirement related to liquid nitrogen

8.1.6 Materials of construction

Requirements mentioned in the OSV Chemical Code Chapter 18, section 18.4 are to be referred to.

8.1.7 Vent system for cargo containment

Requirements mentioned in the OSV Chemical Code Chapter 18, section 18.5 are to be referred to.

8.1.8 Cargo transfer

Requirements mentioned in the OSV Chemical Code Chapter 18, section 18.6 are to be referred to.

8.1.9 Vapour detection

Requirements mentioned in the OSV Chemical Code Chapter 18, section 18.7 are to be referred to.

8.1.10 Gauging and level detection

Requirements mentioned in the OSV Chemical Code Chapter 18, section 18.8 are to be referred to.

8.1.11 Emergency shutdown system

Requirements mentioned in the OSV Chemical Code Chapter 18, section 18.9 are to be referred to.

8.1.12 Carriage on open deck

Requirements mentioned in the OSV Chemical Code Chapter 18, section 18.11 are to be referred to.

SECTION 6

ELECTRICAL INSTALLATIONS, INSTRUMENTATION AND AUTOMATION

1 Hazardous location and types of equipment

1.1 General

1.1.1 OSVs are to comply with the requirements of Pt D, Ch 7, Sec 5.

1.1.2 Electrical equipment, cables and wiring shall not be installed in the hazardous location unless it conforms to IEC 60092-502.

2 Additional requirements for ships granted with HNLS and/or WELLSTIM additional service features

2.1 General

2.1.1 Requirements mentioned in OSV Chemical Code Chapter 8 are to be referred to.

Note 1: Specific attention should be drawn on the requirements mentioned in OSV Chemical Code, section 8.1.7.

2.1.2 Remote control for loading and unloading

Requirements mentioned in OSV Chemical Code Chapter 11, section 11.1.2 are to be referred to.

2.2 Additional requirements for ships granted with notations -FP \leq 60°C and/or -toxic

2.2.1 In addition to the requirements mentioned in [2.1], for vapour detection, requirements mentioned in OSV Chemical Code Chapter 11, section 11.4 are to be referred to.

2.3 Additional requirements for ships granted with notation -acid

2.3.1 In addition to the requirements mentioned in [2.1], the following apply:

- a) For hydrogen risk, requirements mentioned in IBC Code Chapter 15, section 15.11.5 are to be referred to.
- b) For detection of leakage of cargo in adjacent spaces, requirements mentioned in IBC Code Chapter 15, section 15.11.7 are to be referred to.

SECTION 7

FIRE PREVENTION, PROTECTION AND EXTINGUISHMENT

1 General

1.1 Application

1.1.1 Unless otherwise specified, this Section applies to ships intended to carry products as mentioned in Ch 3, Sec 1, [1.1]

1.1.2 For ships intended to carry only liquid identified as non-flammable and not covered by the OSV Chemical Code, the fire-fighting requirements are to be to the satisfaction of the Society.

2 Fire prevention and protection

2.1 Ships granted with additional service features HNLS and/or WELLSTIM

2.1.1 For ships granted with notation $-FP \leq 60^{\circ}\text{C}$, with reference to OSV Chemical Code Chapter 4, section 4.2.2, doors to spaces not having access to accommodation, service and machinery spaces and control stations, such as cargo control stations and store-rooms, may be permitted within the deck area mentioned in OSV Chemical Code Chapter 1, Section 1.2.7.3, provided the boundaries of the spaces are insulated to A-60 standard.

3 Fire fighting

3.1 Ships carrying oil product

3.1.1 For ships of more than or equal to 500 GT, the requirements in Part C, Chapter 4 as they would apply to cargo ships of 2000 tons gross tonnage and over, are to be complied with.

in addition, the following requirements apply:

- Pt C, Ch 4, Sec 6, [1.2.4], item d)
- Pt D, Ch 7, Sec 6, [3.2] and Pt D, Ch 7, Sec 6, [3.3].

3.2 Ships granted with additional service features HNLS and/or WELLSTIM

3.2.1 Requirements mentioned in OSV Chemical Code Chapter 9 are to be referred to.

Note 1: OSV Chemical Code Chapter 9 requirements are referring both to SOLAS II-2 and the IBC Code Chapter 17. Attention is drawn on the OSV Chemical Code Chapter 9, [9.2] and [9.3] that provide specific requirements for the cargo pump-rooms and the cargo area.

Note 2: Attention is drawn on the OSV Chemical Code Chapter 9, sections 9.1.2, 9.1.3 and 9.1.4 about relaxation of requirements for ships carrying non-flammable and/or having a flashpoint equal or greater than 60°C .

4 Personnel protection

4.1 Ships carrying oil products

4.1.1 Fire-fighters outfits

Two additional fire-fighters outfits are to be provided.

4.2 Ships granted with additional service features HNLS and/or WELLSTIM

4.2.1 General

Requirements mentioned in OSV Chemical Code Chapter 14, sections 14.1, 14.2, 14.3 and 14.4 are to be referred to.

4.2.2 Carriage of contaminated backloads

Requirements mentioned in OSV Chemical Code Chapter 16, section 16.4.2.2, are to be referred to.

4.3 Additional requirements for ships granted with notation -LG

4.3.1 In addition to the requirements mentioned in [4.2] requirements mentioned in OSV Chemical Code Chapter 18, section 18.10, and consequently, in OSV Chemical Code Chapter 14, sections 14.3 and 14.4 are to be referred to.

Part E
**Service Notations for
Offshore Service Vessels and Tugs**

Chapter 4

FIRE FIGHTING SHIPS

- SECTION 1 GENERAL**
- SECTION 2 HULL AND STABILITY**
- SECTION 3 MACHINERY AND SYSTEMS**
- SECTION 4 FIRE PROTECTION AND EXTINCTION**

SECTION 1 GENERAL

1 General

1.1 Application

1.1.1 Ships complying with the requirements of this Chapter are eligible for the assignment of the service notation **fire-fighting**, as defined in Pt A, Ch 1, Sec 2, [4.8.2].

1.1.2 Ships dealt with in this Chapter are to comply with:

- Part A of the Rules
- NR216 Materials and Welding
- applicable requirements according to Tab 1.

Table 1 : Applicable requirements

Item		Greater than or equal to 500 GT	Less than 500 GT
Ship arrangement	L ≥ 90 m	• Part B	• NR566
	L < 90 m	• NR600	• NR566
Hull	L ≥ 90 m	• Part B • Ch 4, Sec 2	• Part B • Ch 4, Sec 2
	L < 90 m	• NR600	• NR600
Stability		• Part B • Ch 4, Sec 2	• NR566 • Ch 4, Sec 2
Machinery and cargo systems		• Part C • Ch 4, Sec 3	• NR566 • Ch 4, Sec 3
Electrical installations		• Part C	• NR566
Automation		• Part C	• NR566
Fire protection, detection and extinction		• Part C • Ch 4, Sec 4	• NR566 • Ch 4, Sec 4
<p>Note 1: NR566: Hull Arrangement, Stability and Systems for Ships less than 500 GT. NR600: Hull Structure and Arrangement for the Classification of Cargo Ships less than 65 m and Non Cargo Ships less than 90 m.</p>			

SECTION 2

HULL AND STABILITY

1 Stability

1.1 Intact stability

1.1.1 General

The stability of the ship for the loading conditions defined in Pt B, Ch 3, App 2, [1.2.11] is to be in compliance with the requirements in Pt B, Ch 3, Sec 2.

1.1.2 Additional criteria

The loading conditions reported in the trim and stability booklet, with the exception of lightship, are also to be checked in order to investigate the ship's capability to support the effect of the reaction force of the water jet in the beam direction due to the monitors fitted on board.

A fire-fighting ship may be considered as having sufficient stability, according to the effect of the reaction force of the water jet in the beam direction due to the monitors fitted on board, if the heeling angle of static equilibrium θ_0 , corresponding to the first intersection between heeling and righting arms (see Fig 1), is less than 5° .

The heeling arm may be calculated as follows:

$$b_h = \frac{\sum R_i \cdot h_i + S \cdot (T/2 - e)}{9,81 \cdot \Delta} \cdot \cos \theta$$

where:

b_h : Heeling arm, in m, relevant to the reaction force of the water jet of the monitors fitted on board, and to the effect of transversal manoeuvring thrusters. The monitors are assumed to be oriented in beam direction parallel to the sea surface, so as to consider the most severe situation

R_i : Reaction force, in kN, of the water jet of each monitor fitted on board (see Fig 2)

h_i : Vertical distance, in m, between the location of each monitor and half draught (see Fig 2)

Figure 1 : Heeling and righting arm curves

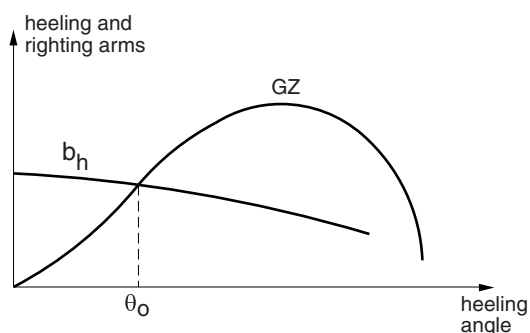

S : Thrust, in kN, relevant to manoeuvring thruster(s), if applicable (see Fig 2)

e : Vertical distance, in m, between the manoeuvring thruster axis and keel (see Fig 2)

Δ : Displacement, in t, relevant to the loading condition under consideration

T : Draught, in m, corresponding to Δ (see Fig 2).

2 Structure design principles

2.1 Hull structure

2.1.1 The strengthening of the structure of the ships, where necessary to withstand the forces imposed by the fire-extinguishing systems when operating at their maximum capacity in all possible directions of use, are to be considered by the Society on a case-by-case basis.

2.2 Water and foam monitors

2.2.1 The seatings of the monitors are to be of adequate strength for all modes of operation.

3 Other structures

3.1 Arrangement for hull and superstructure openings

3.1.1 Deadlights and shutters are to be provided as requested by Ch 4, Sec 4, [2.2.1].

Figure 2 : Reaction force of water jet in the beam direction due to monitors

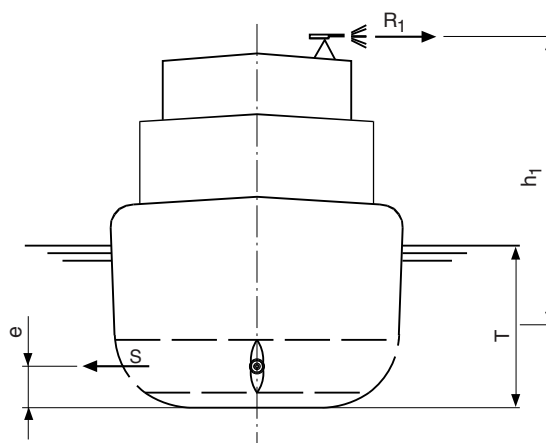

SECTION 3

MACHINERY AND SYSTEMS

1 General

1.1 Application

1.1.1

- a) This Section provides, for ships having the service notations **fire-fighting E**, **fire-fighting 1**, **fire-fighting 2**, and **fire-fighting 3**, specific requirements for:
- machinery systems
 - fire-fighting systems installed on board the ship and intended for fighting of external fires.
- b) The requirements related to the self-protection water-spraying systems fitted to fire-fighting ships having the additional service feature **water spraying** are given in Ch 4, Sec 4.

1.2 Documents to be submitted

1.2.1 The documents listed in Tab 1 are to be submitted.

2 Design of machinery systems

2.1 Manoeuvrability

2.1.1 General

- a) The ratios between the main ship dimensions and the power of propulsion engines and of engines driving side thrusters are to be adequate and such as to ensure an effective manoeuvrability during fire-fighting operations.
- b) The side thrusters and the main propulsion system are to be capable of maintaining the ship in position in still water and of withstanding the reaction forces of the water monitors even in the most unfavourable combination of operating conditions of such monitors, without requiring more than 80% of the above propulsive power, to prevent engine overload.

Table 1 : Documents to be submitted

No.	Description of the document (1)	Status of the review (2)
1	General arrangement showing the disposition of all fire-fighting equipment	I
2	Details of all fire-fighting equipment such as pumps and monitors, including their capacity, range and trajectory of delivery	A
3	Schematic diagram of the water fire-fighting system	A
4	Plan of the water monitor seating arrangements	A
5	Diagram of local control and remote control system for water monitors	A
6	Schematic diagram of the fixed foam fire-extinguishing system	A
7	Plan of the foam monitor seating arrangements (3)	A
8	Diagram of local control and remote control system for foam monitors (3)	A
9	Specification and plan showing the location of firemen's outfits	A
10	Particulars of the means of keeping the ship in position during fire-fighting operations	A
11	Calculation of the required fuel oil capacity according to [2.2.1] (4)	I
12	Operating manual	I
<p>(1) Diagrams are also to include, where applicable:</p> <ul style="list-style-type: none"> • the (local and remote) control and monitoring systems and automation systems • the instructions for the operation and maintenance of the piping system concerned (for information). <p>(2) A : For approval I : For information.</p> <p>(3) For ships having the service notation fire-fighting 3.</p> <p>(4) For ships having one of the following service notations: fire-fighting 1, fire-fighting 2, fire-fighting 3.</p>		

2.1.2 Power control system

An operating control system of the power supplied by the engines is to be provided, including:

- an alarm device operating at 80% of the maximum propulsive power available in free navigation, and
- an automatic reduction of power on reaching 100% of the above propulsive power,

to prevent engine overload.

Note 1: Such operating control system may not be required, at the discretion of the Society, in cases where the installed power is redundant.

2.2 Fuel oil capacity

2.2.1 All ships are to have fuel oil tanks whose capacity is to be sufficient for continuous fighting of fires whilst all the water monitors are operating for a period of time not less than:

- 24 hours in the case of ships having the service notation **fire-fighting 1**
- 96 hours in the case of ships having the service notation **fire-fighting 2** or **fire-fighting 3**.

This capacity is to be additional to that provided for the normal operation of the ship (propulsion, etc.).

Note 1: The determination of such required capacity is the responsibility of the Designer.

2.3 Scuppers

2.3.1 When the ship is protected by a water-spraying system, suitable scuppers or freeing ports are to be provided to ensure efficient drainage of water accumulating on deck surfaces when such system is in operation.

3 General requirements for fire-fighting systems

3.1 General

3.1.1 This Article applies to both water fire-extinguishing systems and fixed foam fire-extinguishing systems.

3.2 Independence of pumping and piping systems

3.2.1 The pumps and piping system serving the water and foam monitors are not to be used for other services except for the water-spraying system referred to in Ch 4, Sec 4 and the hose connections required for the portable fire-fighting equipment referred to in [6.2].

3.2.2 Where the water or foam monitor pumps are also used for the water-spraying system referred to in Ch 4, Sec 4

or for the hose connections required for the portable fire-fighting equipment referred to in [6.2]:

- it is to be possible to segregate each system from the others by means of valves, so that each system can be operated independently or simultaneously with the others, and
- the pump capacity is sufficient to serve all systems simultaneously.

3.3 Design and construction of piping systems

3.3.1 General

Fire-fighting piping systems are to comply with the provisions of Pt C, Ch 1, Sec 10.

3.3.2 Sea suctions

- a) Sea suctions for fire-fighting pumps are not to be used for other purposes.
- b) Sea suctions and associated sea chests are to be so arranged as to ensure a continuous and sufficient water supply to the fire-fighting pumps, not adversely affected by the ship motion or by water flow to or from bow thrusters, side thrusters, azimuth thrusters or main propellers.
- c) Sea suctions are to be located as low as practicable to avoid:
 - clogging due to debris or ice
 - oil intake from the surface of the sea.
- d) Sea water inlets are to be fitted with strainers having a free passage area of at least twice that of the sea suction valve. Efficient means are to be provided for clearing the strainers.

3.3.3 Pumps

- a) Means are to be provided to avoid overheating of the fire-fighting pumps when they operate at low delivery rates.
- b) The starting of fire-fighting pumps when sea water inlet valves are closed is either to be prevented by an interlock system or to trigger an audible and visual alarm.
- c) It is to be demonstrated that the available net positive suction head is more than 1m above the net positive suction head leading to pump cavitation, i.e. $NPSH_A - 1\text{m water column} > NPSH_R$.

3.3.4 Valves

- a) If their nominal diameter exceeds 450 mm, sea water suction valves and water delivery valves are to be provided with a power actuation system as well as a manual operation device.
- b) The sea water suction valve and water delivery valve and pump prime movers are to be operable from the same position.

3.3.5 Protection against corrosion

Means are to be provided to ensure adequate protection against:

- internal corrosion, for all piping from sea water inlets to water monitors
- external corrosion, for the lengths of piping exposed to the weather.

3.3.6 Piping arrangement

Suction lines are to be as short and straight as practicable.

3.4 Monitors

3.4.1 Design of monitors

- a) Monitors are to be of an approved type.
- b) Monitors are to be of robust construction and capable of withstanding the reaction forces of the water jet.

3.5 Monitor control

3.5.1 General

Water monitors and foam monitors are to be operated and controlled with a remote control system located in a common control station having adequate overall visibility.

3.5.2 Manual control

In addition to the remote control system, a local manual control is to be arranged for each monitor. It is to be possible to:

- disconnect the local manual control from the control station
- disconnect the remote control system, from a position close to each monitor, to allow the operation with the local manual control.

3.5.3 Valve control

The valve control is to be designed so as to prevent pressure hammering.

3.5.4 Control system

- a) The control system is to comply with the relevant provisions of Pt C, Ch 3, Sec 1 and Pt C, Ch 3, Sec 2.
- b) The control system is to be designed with a redundancy level such that lost function can be restored within 10 minutes.

- c) In the case of a hydraulic or pneumatic control system, the control power units are to be duplicated.

3.5.5 Marking

All control and shut-off devices are to be clearly marked, both locally and in the control station.

4 Water fire-fighting system

4.1 Characteristics

4.1.1

- a) For ships having the service notation **fire-fighting 1**, **fire-fighting 2** or **fire-fighting 3**, the number of pumps and monitors and their characteristics are to be in accordance with the requirements given in Tab 2.
- b) For ships having the service notation fire-fighting E, the characteristics of the water fire-fighting system will be given special consideration by the Society.

4.2 Monitors

4.2.1 Monitors are to be so arranged as to allow an easy horizontal movement of at least 90° equally divided about the centreline of the ship. The allowed vertical angular movement is to be such that the height of throw required in Tab 2 can be achieved.

4.2.2 The monitors are to be located such that the water jet is free from obstacles, including ship's structure and equipment.

4.2.3 The monitors are to be capable of throwing a continuous full water jet without significant pulsations and compacted in such a way as to be concentrated on a limited surface.

4.2.4 At least two monitors are to be equipped with a device to make the dispersion of the water jet (spray jet) possible.

Table 2 : Number of pumps and monitors and their characteristics

Required characteristics	Service notations		
	fire-fighting 1	fire-fighting 2	fire-fighting 3
minimum number of water monitors	2	3	4
minimum discharge rate per monitor (m ³ /h)	1200	2400	2400
minimum number of fire-fighting pumps	1	2	2
minimum total pump capacity (m ³ /h) (1)	2400	7200	9600
length of throw of each monitor (m) (2) (4)	120	150	150
height of throw of each monitor (m) (3) (4)	45	70	70
<p>(1) Where the water monitor pumps are also used for the self-protection water-spraying system and / or the hose connections for portable fire-fighting, their capacity is to be sufficient to ensure the simultaneous operation of the three systems at the required performances.</p> <p>(2) Measured horizontally from the monitor outlet to the mean impact area.</p> <p>(3) Measured vertically from the sea level, the mean impact area being at a distance of at least 70 m from the nearest part of the ship.</p> <p>(4) The length and height of throw are to be capable of being achieved with the required number of monitors operating simultaneously in the same direction.</p>			

4.3 Piping

4.3.1 The maximum design water velocity is not normally to exceed 4 m/s in the piping between pumps and water monitors. Higher velocity may however be accepted on a case-by-case basis and provided the concerned pipe length remains as short as possible.

b) The height of throw is to be at least 50 m above the sea level, when both monitors are in operation at the maximum foam production rate.

5 Fixed foam fire-extinguishing system

5.1 General

5.1.1 Ships having the service notation **fire-fighting ship 3** are to be equipped with a fixed low expansion foam monitor system complying with the provisions of [3] and with those of this Article.

5.1.2 Ships having the service notation **fire-fighting 1**, **fire-fighting 2** or **fire-fighting E** are not required to be equipped with a fixed low expansion foam monitor system. When provided however, such system is to comply with the provisions of [3] and with those of this Article, except that some relaxations in these provisions may be accepted by the Society.

5.2 Characteristics

5.2.1 Foam expansion ratio

The foam expansion ratio is not to exceed 12.

5.2.2 Foam monitors

a) The ship is to be fitted with two foam monitors, each having a foam solution capacity not less than 300 m³/h.

5.2.3 Foam concentrate capacity

Sufficient foam concentrate is to be available for at least 30 min of simultaneous operation of both monitors at maximum capacity.

5.3 Arrangement

5.3.1 Foam generating system

The foam generating system is to be of a fixed type with separate foam concentrate tank, foam-mixing units and piping to the monitors.

5.3.2 Pumps

The pumps of the water monitor system may be used for supplying water to the foam monitor system. In such case, it may be necessary to reduce the pump water delivery pressure to ensure correct water pressure for maximum foam generation.

6 Portable fire-fighting equipment

6.1 Portable high expansion foam generator

6.1.1 Ships having the service notation **fire-fighting 2** or **fire-fighting 3** are to be equipped with a portable high expansion foam generator having a foam capacity not less than 100 m³/min for fighting of external fires.

6.1.2 The total capacity of foam concentrate is to be sufficient for 30 min of continuous foam production. The foam

concentrate is to be stored in portable tanks of about 20 litres capacity.

6.2 Hydrants and fire hoses

6.2.1 Hydrants

- Hydrants are to be provided in accordance with Tab 3.
- At least half of the required hydrants are to be arranged on the main weather deck.
- Where hydrants are fed by the pumps serving the monitor supply lines, provision is to be made to reduce the water pressure at the hydrants to a value permitting safe handling of the hose and the nozzle by one man.

Table 3 : Number of hydrants

fire-fighting E	fire-fighting 1	fire-fighting 2	fire-fighting 3
4 at each side	4 at each side	8 at each side	8 at each side (1)
(1) May be increased to 10 hydrants at each side, depending on the ship's length.			

6.2.2 Fire hose boxes

- At least one box containing fire hoses is to be provided for every two hydrants.
- Each box is to contain two fire hoses complete with dual-purpose (spray/jet) nozzles.

6.2.3 Fire hoses

- Fire hoses and associated nozzles are to be of a type approved by the Society.
- Fire hoses are to be of 45 to 70 mm in diameter and generally are to be 20 m in length.

7 Firemen's outfits

7.1 Number and characteristics

7.1.1 The ship is to be fitted with firemen's outfits in accordance with Tab 4.

Note 1: The number of firemen's outfits required in Tab 4 is the minimum total number of firemen's outfits on-board. Firemen's outfits provided for compliance with e.g. SOLAS II-2/10 may also be counted in this number.

Table 4 : Number of firemen's outfits

fire-fighting E	fire-fighting 1	fire-fighting 2	fire-fighting 3
4	4	8	8

7.1.2 The air breathing apparatuses, protective clothing and electric safety lamps constituting parts of firemen's outfits are to be of a type approved by the Society.

7.1.3 Breathing apparatuses are to be of the self-contained type. They are to have a capacity of at least 1200 litres of free air.

At least one spare air bottle is to be provided for each apparatus.

7.1.4 The firemen's outfits are to be stored in a safe position readily accessible from the open deck.

7.2 Compressed air system for breathing apparatuses

7.2.1 General

Ships are to be equipped with a high pressure air compressor complete with all fittings necessary for refilling the bottles of air breathing apparatuses. The compressor is to be located in a suitable sheltered location.

7.2.2 Capacity

The capacity of the compressor is to be sufficient to allow the refilling of the bottles of all air breathing apparatuses in no more than 30 min.

7.2.3 Accessories

- The compressor is to be fitted on the air suction with a suitable filter.
- The compressor is to be fitted on the delivery with oil separators and filters capable of preventing passage of oil droplets or vapours to the air bottles.

8 Testing

8.1 General

8.1.1 The provisions of this Article are related to the workshop and on board tests to be carried out for:

- machinery systems
- fire-fighting systems.

They supplement those required in Part C, Chapter 1 for machinery systems.

8.2 Workshop tests

8.2.1 Tests for material

- Materials used for the housing of fire-fighting pumps are to be subjected to a tensile test at ambient temperature according to the relevant provisions of NR216 Materials and Welding.
- Materials used for pipes, valves and other accessories are to be tested in accordance with the provisions of Pt C, Ch 1, Sec 10, [20.3].

8.2.2 Hydrostatic testing

After completion of manufacture and before installation on board, pipes, valves, accessories and pump housings are to

be submitted to a hydrostatic test in accordance with the provisions of Pt C, Ch 1, Sec 10, [20.4].

8.3 On board tests

8.3.1 Fixed fire-fighting systems

- a) After assembly on board, the water fire-fighting system and the fixed foam fire-extinguishing system are to be checked for leakage at normal operating pressure.

- b) The water fire-fighting system and fixed foam fire-extinguishing system are to undergo an operational test on board the ship, to check their characteristics and performances.

8.3.2 Propulsion and manoeuvring systems

- a) A test is to be performed to check the manoeuvring capability of the ship.
- b) The capability of the side thrusters and of the main propulsion system to maintain the ship in position with all water monitors in service without requiring more than 80% of the propulsive power is to be demonstrated.

SECTION 4

FIRE PROTECTION AND EXTINCTION

1 General

1.1 Application

1.1.1 This Section provides, for ships having the service notations **fire-fighting 1**, **fire-fighting 2** and **fire-fighting 3**, specific requirements for:

- fire protection
- self-protection water-spraying system.

These requirements supplement those given in Part C, Chapter 4.

1.1.2 For ships having the service notation **fire-fighting E**, fire protection arrangements will be given special consideration by the Society.

1.2 Documents to be submitted

1.2.1 The documents listed in Tab 1 are to be submitted for approval.

Table 1 : Documents to be submitted

No.	Description of the document	I/A (1)
1	Plan showing the structural fire division, including doors and other closing devices of openings in A and B class divisions	A
2	Fire test reports for insulating materials	I
3	Schematic diagram of the fixed self-protection water-spraying system	A
(1) A: For approval; I: For information		

2 Fire protection of exposed surfaces

2.1 Structural fire protection

2.1.1 On ships having the service notation **fire-fighting 1**, all exterior boundaries above the lightest operating water-line, including superstructures and exposed decks, are to be of steel and are to be internally insulated so as to form A-60 class divisions.

2.1.2 On ships having the service notation **fire-fighting 2** or **fire-fighting 3**, all exterior boundaries are to be of steel but they need not be insulated.

2.1.3 On ships granted with the additional service feature **water spraying**:

- the provisions of [2.1.1] need not apply, and
- aluminium may be accepted as an alternative to steel. No additional fire insulation is required in this case.

Note 1: The allowable arrangements for the external boundaries of fire-fighting ships are summarized in Tab 2 below in order to ease the reading.

Table 2 : summary of additional requirements for external boundaries

Material of the external boundaries	fire-fighting 1	fire-fighting 2 or fire-fighting 3
Steel	Additional requirement: <ul style="list-style-type: none"> • A-60 insulation, or • Self-protection water-spraying system complying with the provisions of [3] 	No additional requirement
Aluminium	Additional requirement: Self-protection water-spraying system complying with the provisions of [3]	

2.2 Deadlights and shutters

2.2.1 On ships for which the additional service feature **water spraying** is not assigned, steel deadlights or external steel shutters are to be provided on all windows, sidescuttles and navigation lights, except for the windows of the navigating bridge.

3 Self-protection water-spraying system

3.1 General

3.1.1 The provisions of this Article apply to the self-protection water-spraying systems fitted to ships having the additional service feature **water spraying**. They supplement those given in Pt C, Ch 4, Sec 14, [6].

3.2 Capacity

3.2.1 The capacity of the self-protection water-spraying system is to be not less than 10 l/min for each square metre of protected area. In the case of surfaces which are internally insulated, such as to constitute A-60 class divisions, a lower

capacity may be accepted, provided it is not less than 5 l/min for each square metre of protected area.

3.3 Arrangement

3.3.1 Areas to be protected

The fixed self-protection water-spraying system is to provide protection for all vertical areas of the hull and superstructures as well as monitor foundations and other fire-fighting arrangements, and is to be fitted in such a way as not to impair the necessary visibility from the wheelhouse and from the station for remote control of water monitors, also during operation of spray nozzles.

3.3.2 Sections

The fixed self-protection water-spraying system may be divided into sections so that it is possible to isolate sections covering surfaces which are not exposed to radiant heat.

3.3.3 Spray nozzles

The number and location of spray nozzles are to be suitable to spread the sprayed water uniformly on areas to be protected.

3.4 Pumps

3.4.1 Use of pumps serving other systems

The following pumps may be used for the self-protection water-spraying system:

- fire pumps referred to in Pt C, Ch 4, Sec 6, [1.3]
- water monitor system pumps referred to in Sec 4, [4].

In this case, a shut-off valve is to be provided to segregate the systems concerned.

3.4.2 Capacity of the pumps

- a) The pumps of the self-protection water-spraying system are to have a capacity sufficient to spray water at the required pressure from all spray nozzles of the system.
- b) Where the pumps serving the self-protection water-spraying systems are also used for another service, their capacity is to be sufficient to ensure the simultaneous operation of both systems at the required performances.

3.5 Piping system and spray nozzles

3.5.1 General

Pipes are to be designed and manufactured according to the requirements of Pt C, Ch 1, Sec 10.

3.5.2 Protection against corrosion

Steel pipes are to be protected against corrosion, both internally and externally, by means of galvanising or equivalent method.

3.5.3 Drainage cocks

Suitable drainage cocks are to be arranged and precautions are to be taken in order to prevent clogging of spray nozzles by impurities contained in pipes, nozzles, valves and pumps.

Part E
**Service Notations for
Offshore Service Vessels and Tugs**

Chapter 5
OIL RECOVERY SHIPS

- SECTION 1 GENERAL**
- SECTION 2 HULL AND STABILITY**
- SECTION 3 MACHINERY AND SYSTEMS**
- SECTION 4 ELECTRICAL INSTALLATIONS**
- SECTION 5 FIRE PROTECTION, DETECTION AND EXTINCTION**

SECTION 1 GENERAL

1 General

1.1 Application

1.1.1 Ships complying with the requirements of this Rule Note are eligible for the assignment of service notation **oil recovery** as defined in Pt A, Ch 1, Sec 2, [4.8.3].

1.1.2 Ships dealt with in this Chapter are to comply with:

- Part A of the Rules
- NR216 Materials and Welding
- applicable requirements according to Tab 1.

1.1.3 Additional service feature OILTREAT

The additional service feature **OILTREAT** may be assigned to the ships designed and equipped to recover polluted water which is subjected to a chemical and/or a physical treatment, in order to separate the oil from the polluted water. The separated oil is to be stored and transported in dedicated tanks.

1.1.4 Additional service feature SECOND-LINE

The additional service feature **SECOND-LINE** may be assigned to the ships designed and equipped to recover polluted water in the event of spills of oils which have, at the time of recovery, a flash point exceeding 60°C (closed cup test).

This service feature is not to be assigned to oil recovery ships carrying heated recovered oils within 15°C of their flash point.

1.2 Definitions

1.2.1 Oil recovery ship

An oil recovery ship is a ship specially equipped with a fixed installation and/or a mobile equipment for the removal of oil from the sea surface and its retention on board, carriage and subsequent unloading.

1.2.2 Recovered oil

Recovered oil is the top layers of polluted water collected by means of skimmers, rotating disk, floating pumps or equivalent systems together with sweeping arms, booms or similar devices.

Table 1 : Applicable requirements

Item		Greater than or equal to 500 GT	Ships less than 500 GT
Ship arrangement	L ≥ 65 or 90 m (1)	<ul style="list-style-type: none"> • Ch 5, Sec 2 • Part B 	<ul style="list-style-type: none"> • Ch 5, Sec 2 • NR566
	L < 65 or 90 m (1)	<ul style="list-style-type: none"> • NR600 	<ul style="list-style-type: none"> • Ch 5, Sec 2 • NR566
Hull	L ≥ 65 or 90 m (1)	<ul style="list-style-type: none"> • Ch 5, Sec 2 • Part B 	<ul style="list-style-type: none"> • Ch 5, Sec 2 • Part B
	L < 65 or 90 m (1)	<ul style="list-style-type: none"> • NR600 	<ul style="list-style-type: none"> • NR600
Stability		<ul style="list-style-type: none"> • Ch 5, Sec 2 • Part B 	<ul style="list-style-type: none"> • Ch 5, Sec 2 • NR566
Machinery and cargo systems		<ul style="list-style-type: none"> • Ch 5, Sec 3 • Part C 	<ul style="list-style-type: none"> • Ch 5, Sec 3 • NR566
Electrical installations		<ul style="list-style-type: none"> • Ch 5, Sec 4 • Part C 	<ul style="list-style-type: none"> • Ch 5, Sec 4 • NR566
Automation		<ul style="list-style-type: none"> • Part C 	<ul style="list-style-type: none"> • NR566
Fire protection, detection and extinction		<ul style="list-style-type: none"> • Ch 5, Sec 5 • Part C 	<ul style="list-style-type: none"> • Ch 5, Sec 5 • NR566
<p>(1) Refer to the scope of application of NR600. Note 1: NR566: Hull Arrangement, Stability and Systems for Ships less than 500 GT. NR600: Hull Structure and Arrangement for the Classification of Cargo Ships less than 65 m and Non Cargo Ships less than 90 m.</p>			

1.2.3 Oil recovery tank

An oil recovery tank is a tank intended for the retention and the transportation of recovered oil.

For ships assigned with the additional service feature **OIL-TREAT**, the oil recovery tanks may be classified in two different categories:

- those intended for the retention of oil removed and separated from sea water, also named accumulation tanks
- those intended for the retention of polluted water only, also named settling tanks.

1.2.4 Oil recovery pump room

An oil recovery pump room is a space containing the pumps and their accessories for the handling of recovered oil.

1.2.5 Oil recovery area

The oil recovery area is the part of the ship that contains the oil recovery tanks, oil recovery pumps rooms, cofferdams, ballast or void spaces surrounding the integral tanks and

hold spaces in which independent tanks are located, and the following deck areas:

- the deck area above the oil recovery tanks
- the deck area extending transversely and longitudinally from the oil recovery tanks over a distance of 3 m, when the rule length is greater than 50 m.

Note 1: Oil recovery area definition is not applicable to oil recovery ships assigned with the additional service feature **SECOND-LINE**.

1.2.6 Hazardous areas

The hazardous areas are the areas in which an explosive atmosphere is, or may be, expected to be present in quantities such as to require special precautions for the construction, installation and use of electrical apparatus.

1.2.7 Gas-safe areas

The gas-safe areas are the gas areas which are not defined as hazardous.

SECTION 2

HULL AND STABILITY

1 General

1.1 Documents to be submitted

1.1.1 In addition to the documentation requested in Part B, the documents listed in Tab 1 are to be submitted.

1.2 General arrangement

1.2.1 Tank arrangement

- a) Oil recovery tanks are to be separated from machinery spaces category A, propeller shaft tunnels, dry cargo spaces, accommodations, control stations and service spaces and from drinking water and stores for human consumption by means of a cofferdam or equivalent space. Fuel oil tanks, tanks for ballast water, tanks for liquids used for oil treatment, tanks for anti-pollution liquids, storerooms for oil removal equipment and pump-rooms are considered as spaces equivalent to a cofferdam.

When this cofferdam is impracticable, oil recovery tanks adjacent to the engine room may be accepted provided that:

- boundary bulkheads are accessible for inspection
- the boundary bulkheads are fitted continuously through joining structure to the top of the tank, where full penetration welding is to be carried out
- the tanks are to be pressure tested at each renewal survey.

- b) Oil recovery tanks are to be located abaft the collision bulkhead.

- c) For ships non-exclusively dedicated to oil recovery operations, the ship may use the following tanks as oil recovery tanks:

- tanks covered by the service notation **supply**, if designed for a cargo mass density of, at least, 1,025 t/m³
- water ballast tanks
- fuel oil tanks
- hoppers spaces.

In all cases, the tanks and their associated equipment and piping are to comply with all the requirements for oil recovery tanks.

Fresh water tanks and tanks with a complex inner structure that can lead to obstruction can not be part of the oil recovery tanks.

- d) Oil recovery ships assigned with the additional service feature **SECOND-LINE** do not need to comply with the arrangements referred to in item a), provided that the

segregation requirements for accommodations, control stations, drinking water and stores for human consumption are observed.

1.2.2 Accommodation, control station, service and machinery spaces

- a) Accommodation or service spaces, control stations or machinery spaces category A are to be located outside the oil recovery area.

Note 1: When, instead of a cofferdam, boundaries between oil recovery tanks and machinery spaces of category A are built as described in the second paragraph of [1.2.1], item a), the machinery spaces of category A may be located within the oil recovery area.

- b) Unless they are spaced at least 7 m away from the oil recovery area entrances, air inlets and openings to accommodation, service and machinery spaces category A and control stations should not face the oil recovery area. Doors to spaces not having access to accommodation, service and machinery spaces and control stations, such as oil recovery control stations, storerooms or equipment rooms, may be permitted by the Society within the 7 m zone specified above, provided the boundaries of the spaces are insulated to A-60 standard.

- c) When the additional service feature **SECOND-LINE** is assigned, the arrangement referred to in items a) and b) may be disregarded.

1.2.3 Access

- a) Access hatches (at least 600 mm x 600 mm of clear opening) within the oil recovery area are to be direct from the open deck. Such access should be suitable for cleaning and gas-freeing.

- b) For ships assigned with the additional service feature **SECOND-LINE**, the following requirements may apply instead of item a):

- Access to oil recovery tanks is to be direct from the open deck and such as to ensure their complete inspection, except for access to cargo tanks in double bottoms that may be through a cargo pump-room, pump-room, deep cofferdam, pipe tunnel or similar dry compartment, provided the ventilation of these spaces complies with Ch 5, Sec 5, [2.2]

- Access to oil recovery pump rooms does not need to be from the open deck, provided the access is independent of watertight doors.

Table 1 : Documents to be submitted

No.	Description of the document	Status of the review (1)
1	General arrangement	A
2	General arrangement of access and openings	A
3	Procedure and limiting conditions for recovering oil, oil recovery transfer, tank cleaning, gas freeing and ballasting	I
4	Specification of the oil removal operational test	I
5	General plan showing the location of tanks intended for the retention of oily residues and systems for their treatment	I
6	Plan of the system for treatment of oily residues and specification of all relevant apparatuses	I
7	Supporting structures of the system for treatment of oily residues	A
8	Operating manual	I
(1) A : For approval I : For information.		

1.2.4 Oil recovery tank construction

- A cargo density of 1,025 t/m³ is to be considered for calculating the internal pressures and forces in cargo tanks according to Pt B, Ch 5, Sec 6 or NR600 as applicable.
- All tank openings and connections to the tank are to terminate above the weather deck and should be located in the tops of the tanks.
- The structural design of the tanks should take into account the carriage temperature, and additional strength calculation may be required in case of risk of sloshing induced loads.

2 Stability

2.1 Intact stability

2.1.1 General

In addition to the standard loading conditions specified in Pt B, Ch 3, App 2, [1.2.1], the following loading cases are to be included in the trim and stability booklet for ships assigned with the service notation **oil recovery**:

- ship in the fully loaded departure to the oil recovery spot having all the oil recovery equipment installed on board
- ship in the worst anticipated operating during oil recovery operation; the worst operating condition regarding free surface effects when the equipment is fitted in the most unfavourable condition (for example, swiping arm extended).

3 Hull scantlings

3.1 Additional loads

3.1.1 For the checking of structures supporting oil recovery equipment, the reactions induced by this equipment during oil recovery operations may be calculated assuming that the oil recovery operations take place in moderate sea conditions (accelerations reduced by 10%).

3.1.2 If lifting appliances are used during oil recovery operations, the scantling of their supporting structures is to be checked according to Pt B, Ch 1, Sec 1, [1.2].

3.1.3 In case of oil collected in movable tanks fitted on the weather deck, the resulting reactions to be considered for deck scantling are to be calculated, as a rule, according to Pt B, Ch 5, Sec 6 or NR600 as applicable.

4 Construction and testing

4.1 Testing

4.1.1 Oil removal equipment

Tests are to be carried out according to a specification submitted by the interested Party, in order to check the proper operation of the oil recovery equipment.

These tests may be performed during dock and sea trials.

SECTION 3

MACHINERY AND SYSTEMS

1 General

1.1 Documents to be submitted

1.1.1 The documents listed in Tab 1 are to be submitted.

2 Machinery installation and piping system other than oil recovery system

2.1 Sea water cooling system

2.1.1 One of the suction serving the sea water cooling system (see Pt C, Ch 1, Sec 10, [10.7.1]) is to be located in the lower part of the hull.

2.2 Water fire-extinguishing system

2.2.1 Sea suction serving the fire water pumps are to be located as low as possible.

2.3 Exhaust gas systems

2.3.1

- a) Exhaust lines from engines, gas turbines, boilers and incinerators are to be led outside any hazardous area (as defined in Ch 5, Sec 4) above the deck and are to be fitted with a spark arrester. The spark arrester is not required if the ship is assigned with the additional service feature **SECOND-LINE**.
- b) Where the distance between the exhaust lines of engines and the hazardous areas is less than 3 m, the ducts are to be fitted in a position:
 - near the waterline, if cooled by water injection, or
 - below the waterline, in the other cases.

3 Pumping system, piping system and pump-rooms intended for recovered oil

3.1 Design of pumping and piping systems

3.1.1 General

The provisions of Pt D, Ch 7, Sec 4, [3] and Pt C, Ch 1, Sec 10 are to be complied with, as far as applicable.

3.2 Arrangement of piping systems

3.2.1

- a) Piping systems for handling recovered oil are not to pass through:
 - accommodation spaces
 - service spaces
 - control stations
 - machinery spaces of category A except for ship assigned with the additional service feature **SECOND-LINE**.
- b) Pumping and piping systems intended for recovered oil are to be independent from the other pumping and piping systems of the ship, except in the following cases:
 - If sections of the cargo system covered by the service notation **supply** or if fuel oil tanks are used, means are to be provided to isolate the oil recovery system from any other system from which it may be connected. The connection between the cargo system and the recovered oil transfer piping may consist of movable pipe sections.
 - If water ballast tanks are used as oil recovery tanks when the ship is in oil recovery mode, the water ballast piping is to be blanked-off at the nearest position at the tank before starting the oil recovery operation. The connection between the oil recovery piping and the water ballast tanks is to be done by means of detachable spool pieces.
- c) Piping intended for recovered oil and located below the main deck may run from the tank it serves and penetrate tank bulkheads or boundaries common to longitudinally or transversely adjacent oil recovery tanks, ballast tanks, empty tanks, pump-rooms or oil recovery pump-rooms, provided that inside the tank it serves it is fitted with a stop-valve operable from the weather deck.

As an alternative, where an oil recovery tank is adjacent to an oil recovery pump-room, the stop valve operable from the weather deck may be situated on the tank bulkhead on the oil recovery pump-room side, provided an additional valve is fitted between the bulkhead valve and the oil recovery pump.

A totally enclosed hydraulically operated valve located outside the oil recovery tank may also be accepted, provided that the valve is:

- fitted on the bulkhead of the oil recovery tank it serves
- suitably protected against mechanical damage
- fitted at a distance from the shell as required for damage protection, and
- operable from the weather deck.

- d) Transfer of recovered oil through hatches (by means of flexible hoses or movable piping) is not permitted except if the additional service feature **SECOND-LINE** is assigned.

3.3 Oil recovery pumps

3.3.1

- a) Oil recovery pumps are to comply with the requirements of cargo pumps for **oil tanker, flash point > 60°C** (see Pt D, Ch 7, Sec 4, [3.2]).
- b) Oil recovery pumps are to be capable of being remotely shutdown from a location which is manned during oil recovery operations and from at least one other location outside the oil recovery area.
- c) If an oil recovery pump serves more than one tank, a stop valve is to be fitted in the line of each tank.
- d) For ships non exclusively dedicated to oil recovery operation, the use of portable pumps or pumps serving cargo systems may be permitted, subject to special consideration by the Society.

3.4 Oil recovery pump-rooms

3.4.1

- a) Pump-rooms containing the pumps for handling the recovered oil are to be provided with a fixed fire-extinguishing system suitable for machinery spaces of category A except if the ship is assigned with the additional service feature **SECOND-LINE**.
- b) Means are to be provided to deal with drainage and any possible leakage from oil recovery pumps and valves in the oil recovery pump-room. Bilge pumping arrangement is to be situated entirely within the oil recovery area. The bilge system is to be operable from outside the oil recovery pump-room. Oil recovery pumps may also be used provided they are connected to the oil recovery pump-room bilge piping through a shut-off valve and a non-return valve arranged in series.

- c) For ventilation of oil recovery transfer pump-rooms, see Ch 5, Sec 5, [2].
- d) Oil recovery pump-rooms are to have no direct communication with machinery spaces of category A, except when the ship is assigned with the additional service feature **SECOND-LINE**.

4 Oil recovery tank fittings

4.1 Vent pipes

4.1.1

- a) Vent pipes of oil recovery tanks are to lead to the open at least 2,4 m above the weather deck.
- b) Vent pipes are to be located at a distance of at least 5,0 m measured horizontally from the nearest air intake or opening to accommodations, control stations, service and machinery spaces of category A and other gas-safe spaces and from ignition sources.
- c) Openings of vent pipes are to be directed to open deck and fitted with:
 - flameproof wire gauze made of corrosion resistant material easily removable for cleaning, and
 - closing appliances complying with the provisions of Pt C, Ch 1, Sec 10, [9.1]
- d) For ships non exclusively dedicated to oil recovery operations, portable vent pipes may be accepted.

4.2 Level gauging and overfilling control

4.2.1 Level gauging

Oil recovery tanks are to be fitted with sounding pipes or other level gauging devices of a type approved by the Society.

4.2.2 Overfilling control

- a) Oil recovery tanks are to be fitted with a high level alarm or an overflow control system except if the oil recovery tank is an open hopper space.
- b) The high level alarm is to be of a type approved by the Society and is to give an audible and visual alarm.

Table 1 : Documents to be submitted

No.	Description of the document (1)	Status of the review (2)
1	General plan of the system for oil recovery and specification of all relevant apparatuses	I
2	Schematic arrangement of recovered oil piping and pumping systems	A
3	Tank venting arrangement	A
4	Diagram of the bilge and ballast systems serving the spaces located in the oil recovery area	A
5	Specification of the anti-explosion devices (crankcase explosion relief valves, spark arresters) provided for diesel engines	A
6	Location and arrangement of sea chests for engine cooling and fire-fighting purposes	A
7	Diagram of the oil recovery cargo tank level gauging system with overfilling safety arrangement	A
8	Diagram of the cargo heating system, where applicable	A
(1)	Diagrams are also to include, where applicable, the (local and remote) control and monitoring systems and automation systems.	
(2)	A : For approval I : For information.	

5 Heating systems

5.1

5.1.1 Heating systems fitted to oil recovery tanks are to comply with the provisions of Pt D, Ch 7, Sec 4, [2.6].

6 Additional requirements

6.1 Ships assigned with the additional service feature OILTREAT

6.1.1 When the separating system designed to reduce the oil content in the water being discharged into the sea is of a gravity type (single or in series):

- means for locating the oil/water interface in the oil recovery tanks are to be provided
- discharges of processed water from the separating process are to take place above waterline for visual control
- if chemical additives are added, the coating of the oil recovery tanks is to be compatible. The Shipyard is responsible for providing compatibility information to the ship operator and/or the master
- adequate means are to be provided for cleaning the oil recovery tanks.

6.1.2 Other types of separating system (e.g. gravity type coalescing, centrifugal separator, ...) are to be reviewed on a case-by-case basis.

SECTION 4 ELECTRICAL INSTALLATIONS

1 General

1.1 Application

1.1.1 The requirements in this Section apply, in addition to those contained in Part C, Chapter 2.

1.2 Documentation to be submitted

1.2.1 In addition to the documentation requested in Pt C, Ch 2, Sec 1, [2.1.1], the documents listed in Tab 1 are to be submitted.

2 Design requirements

2.1 System of supply

2.1.1 The following systems of generation and distribution of electrical energy are acceptable:

- a) Direct current:
 - two-wire insulated
- b) Alternating current:
 - single-phase, two-wire insulated
 - three-phase, three-wire insulated.

2.1.2 Earthed systems with hull return are not permitted, with the following exceptions to the satisfaction of the Society:

- a) impressed current cathodic protective systems
- b) limited and locally earthed systems, such as starting and ignition systems of internal combustion engines, provided that any possible resulting current does not flow directly through any hazardous area
- c) insulation level monitoring devices, provided that the circulation current of the devices does not exceed 30 mA under the most unfavourable conditions.

2.1.3 Earthed systems without hull return are not permitted, with the following exceptions:

- a) earthed intrinsically safe circuits and the following other systems to the satisfaction of the Society;
- b) power supplies, control circuits and instrumentation circuits in non-hazardous areas where technical or safety reasons preclude the use of a system with no connection to earth, provided the current in the hull is limited to not more than 5 A in both normal and fault conditions; or
- c) earthed systems, provided that any possible resulting hull current does not flow directly through any hazardous area; or

- d) isolating transformers or other adequate means, to be provided if the distribution system is extended to areas remote from the machinery space.

2.1.4 In insulated distribution systems, no current carrying part is to be earthed, other than:

- a) through an insulation level monitoring device
- b) through components used for the suppression of interference in radio circuits.

2.2 Earth detection

2.2.1 The devices intended to continuously monitor the insulation level of all distribution systems are also to monitor all circuits, other than intrinsically safe circuits, connected to apparatus in hazardous areas or passing through such areas. An audible and visual alarm is to be given, at a manned position, in the event of an abnormally low level of insulation.

3 Hazardous locations and types of equipment

3.1 Electrical equipment permitted in hazardous areas

3.1.1 In order to facilitate the selection of appropriate electrical apparatus and the design of suitable electrical installation, hazardous areas are classified in zones (zone 0, zone 1 and zone 2), according to Pt C, Ch 2, Sec 1, [3.24.3]. The different spaces are to be classified according to Tab 2 or Tab 3, as applicable.

The types of electrical equipment permitted, depending on the zone where they are installed, are specified in Pt C, Ch 2, Sec 3, [10].

3.1.2 The explosion group and temperature class of electrical equipment of a certified safe type are to be at least IIA and T3.

3.2 Additional requirements for machinery installations in hazardous areas

3.2.1 Hazardous areas are not to contain:

- internal combustion engines
- steam turbines and steam piping with a steam temperature in excess of 200°C
- other piping systems and heat exchangers with a surface temperature exceeding 200°
- any other source of ignition.

3.3 Openings, access and ventilation conditions affecting the extent of hazardous areas

3.3.1 There are normally not to be access doors or other openings between a safe space, such as accommodation or service spaces, machinery spaces, control stations and similar spaces, and a hazardous area.

Access (other than access between oil recovery pump-rooms and machinery spaces category A) may, however, be accepted between such spaces and hazardous areas, provided that:

a) safe spaces are fitted with forced ventilation in order to maintain an overpressure therein

b) access doors are:

- 1) of a self-closing type and arranged to swing into the safer space, so that they are kept closed by the overpressure, with the self-closing device capable of shutting the doors against an inclination of 3,5° opposing closure, without hold-back hooks keeping them in an open position, or
- 2) gas-tight, kept closed during oil recovery operation until gas freeing is carried out, and provided with a warning plate (suitable instructions are given in the oil recovery manual).

Table 1 : Documents to be submitted

No.	Description of the document	Status of the review (1)
1	Plan of hazardous areas and location of electrical equipment	A
2	Document giving details of types of cables and safety characteristics of the equipment installed in hazardous areas	A
(1) A : For approval		

Table 2 : Oil recovery ships - Space descriptions and hazardous area zones

Hazardous area	Spaces	
	No.	Description
Zone 0	1	Oil recovery tanks, pipes and equipment containing the recovered oil
Zone 1	2	Areas on open deck or semi-enclosed spaces on open deck within 3 m of any oil recovery tank outlet, oil recovery manifold valve, oil recovery valve, oil recovery pipe flange, oil recovery hatches
Zone 1	3	Cofferdams and enclosed or semi-enclosed spaces adjacent to or immediately above oil recovery tank which do not contain pipes, valves or other equipment for the handling of recovered oil unless separated by gas-tight boundaries and fitted with forced ventilation capable of giving at least 20 air changes per hour. An alarm on the navigation bridge is to be provided to indicate any loss of the required ventilation capacity. The alarm is to be initiated by fall-out of starter relay fan motor
Zone 1	4	For open hopper dredgers operating as oil recovery ships: the area above the hopper extended to the maximum breath of the ship with an unlimited height
Zone 1	5	Oil recovery pump-rooms
Zone 2	6	Enclosed or semi-enclosed spaces for the storage of floating pumps, associated hoses and equipment for the handling of recovered oil unless acceptable means are provided to drain or empty the equipment after completion of oil recovery operation
Zone 2	7	Double bottoms or duct keels located under oil recovery tanks unless separated by gas-tight boundaries and fitted with forced ventilation capable of giving at least 20 air changes per hour. An alarm on the navigation bridge is to be provided to indicate any loss of the required ventilation capacity. The alarm is to be initiated by fall-out of starter relay fan motor
Zone 2	8	Enclosed or semi-enclosed spaces containing pipes, valves or other equipment for the handling of recovered oil unless made of entirely welded construction except for necessary flanged connections to valves, expansion joints, spool pieces and similar fittings or where required for coating, lining, fabrication, inspection or maintenance
Zone 2	9	Enclosed or semi-enclosed spaces containing pipes, valves or other equipment for the handling of recovered oil unless separated by gas-tight boundaries and fitted with forced ventilation capable of giving at least 20 air changes per hour. An alarm on the navigation bridge is to be provided to indicate any loss of the required ventilation capacity. The alarm is to be initiated by fall-out of starter relay fan motor.
Zone 2	10	Areas on open deck over all oil recovery tanks up to a height of 2,4 m above the deck

Table 3 : Oil recovery ships, second-line - Space descriptions and hazardous area zones

Hazardous area	Spaces	
	No.	Description
Zone 2	1	Oil recovery tanks, any pipe work of pressure relief or other venting system for oil recovery tanks, pipes and equipment containing recovered oil

SECTION 5

FIRE PROTECTION, DETECTION AND EXTINCTION

1 General

1.1 Documents to be submitted

1.1.1 The documents listed in Tab 1 are to be submitted for approval.

2 Mechanical ventilation in the oil recovery area

2.1 General

2.1.1 Spaces considered as hazardous are to have a ventilation system independent from those serving gas-safe spaces.

2.2 Ventilation of recovered oil pump rooms

2.2.1 Oil recovery pump rooms are to be provided with a mechanical ventilation system of the extraction type capable of giving at least 20 air changes per hour.

2.2.2 Ventilation intakes are to be so arranged as to minimise the possibility of recycling hazardous vapours from ventilation discharge openings.

2.2.3 Ventilation exhaust ducts are to discharge upwards to a safe area on the weather deck in locations at least 3,0 m from any ventilation intake and opening to accommodations, service and machinery spaces, control stations and other spaces outside the oil recovery area.

2.2.4 Protection screens of not more than 13 mm square mesh are to be fitted on ventilation duct intakes and outlets.

2.2.5 Ventilation fans are to be of non-sparking construction as per Pt C, Ch 4, Sec 1, [3.28].

2.2.6 The ventilation system is to be capable of being controlled from outside the oil recovery pump-room.

2.2.7 Provision is to be made to ventilate such spaces prior to entering the compartment and operating the equipment and a warning notice requiring the use of such a ventilation is to be placed outside the compartment.

2.2.8 Ventilation ducts are not to lead through accommodations, service and machinery spaces or other similar spaces.

2.3 Ventilation of enclosed spaces normally entered during oil recovery operation other than recovery oil pump rooms

2.3.1 Enclosed spaces normally entered within the oil recovery area are to be provided with a mechanical ventilation system of the extraction type capable of giving at least 8 air changes per hour.

2.3.2 Ventilation intakes are to be located at a distance of not less than 3,0 m from the ventilation outlets of oil recovery pump-rooms.

3 Fire protection and fighting

3.1 Vapor detector

3.1.1 At least one portable gas detection instrument capable of measuring flammable vapour concentrations in air and an equipment for oil flashpoint measurements are to be provided on board.

Alternatively, instead of a portable gas detection instrument, a fixed system may be accepted provided that the sample is drawn from a point within 6,0 m from the waterline.

Table 1 : Documents to be submitted

No.	Description of the document (1)	Status of the review (2)
1	Diagram of mechanical and natural ventilation with indication of inlets and outlets serving: <ul style="list-style-type: none"> spaces within the oil recovery area machinery spaces accommodation spaces 	A
2	Specification of flammable gas detectors and flash point measurement equipment	A
3	Drawing and specification of the fixed, if any, or movable fire-fighting system	A
(1)	Diagrams are also to include, where applicable, the (local and remote) control and monitoring systems and automation systems.	
(2)	A : For approval.	

3.2 Structural fire protection

3.2.1 Unless they are located at least 7,0 m from the nearest oil recovery area, exterior boundaries of the superstructures and deckhouses enclosing accommodations and including any overhanging decks which support such accommodations are to be insulated to A-60 standard for the whole of the portions which face the oil recovery areas up to the underside of the navigation bridge deck and for a distance of 3,0 m aft or forward of such areas.

Alternatively to A-60 insulation, a fixed water-spraying system capable of delivering water at a rate of 10 l/m²/min may be accepted. This system is to comply with the requirements listed in Ch 4, Sec 4, [3], except that the only protected area is to be the exterior boundaries of the superstructures and deckhouses enclosing accommodations and including any overhanging decks which support such accommodations facing the oil recovery area.

3.2.2 Windows and sidescuttles fitted within 7,0 m from the nearest oil recovery area are to have the same fire integrity as the bulkhead in which they are fitted. If they have a

lower fire rating because they are protected by the fixed water-spraying system mentioned in [3.2.1], windows and sidescuttles are to be fitted with inside covers of steel or other equivalent material having a thickness equal to the bulkhead in which they are fitted. Where they are not of the fixed type, they are to be such as to ensure an efficient gas-tight closure.

3.2.3 Ships assigned with the additional service feature **SECOND-LINE** do not need to comply with [3.2.1] and [3.2.2].

3.3 Fire-fighting

3.3.1 For the protection of the oil recovery area, the following fire-fighting equipment is to be provided near the working area:

- two dry powder fire extinguishers, each with a capacity of at least 50 kg or equivalent
- at least one portable foam extinguishing applicator complying with Pt C, Ch 4, Sec 14, [3.2.2].

Part E
**Service Notations for
Offshore Service Vessels and Tugs**

Chapter 6

CABLE-LAYING SHIPS

- SECTION 1 GENERAL**
- SECTION 2 HULL AND STABILITY**
- SECTION 3 MACHINERY AND SYSTEMS**
- SECTION 4 FIRE PROTECTION**

SECTION 1 GENERAL

1 General

1.1 Application

1.1.1 Ships complying with the requirements of this Chapter are eligible for the assignment of the service notation **cable laying**, as defined in Pt A, Ch 1, Sec 2, [4.9.8].

1.1.2 Ships dealt with in this Chapter are to comply with:

- Part A of the Rules
- NR216 Materials and Welding
- applicable requirements according to Tab 1.

Table 1 : Applicable requirements

Item		Greater than or equal to 500 GT	Less than 500 GT
Ship arrangement	L ≥ 65 or 90 m (1)	• Part B	• NR566
	L < 65 or 90 m (1)	• NR600	• NR566
Hull	L ≥ 65 or 90 m (1)	• Ch 6, Sec 2 • Part B	• Ch 6, Sec 2 • Part B
	L < 65 or 90 m (1)	• NR600	• NR600
Stability		• Ch 6, Sec 2 • Part B	• Ch 6, Sec 2 • NR566
Machinery and cargo systems		• Ch 6, Sec 3 • Part C	• Ch 6, Sec 3 • NR566
Electrical installations		• Part C	• NR566
Automation		• Part C	• NR566
Fire protection, detection and extinction		• Ch 6, Sec 4 • Part C	• Ch 6, Sec 4 • NR566
<p>(1) Refer to the scope of application of NR600. Note 1: NR566: Hull Arrangement, Stability and Systems for Ships less than 500 GT NR600: Hull Structure and Arrangement for the Classification of Cargo Ships less than 65 m and Non Cargo Ships less than 90 m.</p>			

SECTION 2

HULL AND STABILITY

1 General

1.1 Application

1.1.1 The requirements of this Section apply to ships fitted, in general, with one or more continuous decks, suitable holds for the carriage of cables and superstructures extending for most of the ship's length.

The main characteristics of the ship may vary according to the service primarily performed which may be as follows:

- laying (and possibly burying) submarine cables on the sea bed
- hauling and repairing submarine cables.

1.2 Documents to be submitted

1.2.1 In addition to the documentation requested in Part B, the following documents are to be submitted for approval:

- Structural reinforcements in way of load transmitting elements, such as foundations and fastenings of the equipment to the ship structures.

2 Stability

2.1 Intact stability

2.1.1 General

The stability, the freeboard and the metacentric radius or roll period are to be such as to ensure:

- satisfactory seakeeping performance in working conditions
- a steady working platform in order to facilitate the performance of cable laying and/or repair operations.

Anti-roll tanks or bilge keels of adequate size may be fitted to meet the above requirements.

2.1.2 Tanks intended for liquid consumable

Special attention is to be paid to the arrangement of tanks intended to contain liquid consumables in order to prevent weight variations during service resulting in excessive changes in the ship's trim.

2.1.3 Intact stability criteria

The stability of the ship for the loading conditions in Pt B, Ch 3, App 2, [1.2.1] and for the (departure and arrival) loading conditions corresponding to the maximum draught is to be in compliance with the requirements in Pt B, Ch 3, Sec 2.

2.2 Damage stability for ships where the notation SDS has been required

2.2.1 Application

The requirements of this item apply to cable laying ships carrying less than 240 persons.

Damage stability criteria for cable laying ships carrying 240 persons and more are to be considered by the Society on a case-by-case basis.

2.2.2 General

Cable laying ships are to comply with the survival requirements specified in Pt B, Ch 3, App 3, where the required index R is to be considered as follows in Tab 1 and calculated according to [2.2.3].

Table 1 : Index R

Number of persons: Nb	Index R
Nb ≤ 60	0,8 R
60 < Nb < 240	Linear interpolation between 0,8 R and R (1)
(1) The required index is equal to R for Nb = 240	

2.2.3 Calculation of the required index

$$R = 1 - \frac{5000}{L_S + 2,5N + 15225}$$

where:

$$N = N_1 + 2N_2$$

N_1 : Number of persons for whom lifeboats are provided

N_2 : Number of persons the ship is permitted to carry in excess of N_1 .

Where the conditions of service are such that compliance with R on the basis of $N = N_1 + 2N_2$ is impracticable and where the Society considers that a suitable reduced degree of hazard exists, a lesser value of N may be taken, but in no case less than $N = N_1 + N_2$. The reduced value of N is also to be subject to the agreement of the flag administration.

3 Hull scantlings

3.1 Cable tanks

3.1.1 The net scantlings of cable tanks are to be obtained through direct calculations to be carried out according to Pt B, Ch 7, App 1, where the still water and wave loads are to be calculated for the most severe condition of use.

3.2 Connection of the machinery and equipment with the hull structure

3.2.1 The net scantlings of the structures in way of the connection between the hull structure and the machinery and equipment, constituting the laying or hauling line for submarine cables, are to be obtained through direct calculation to be carried out according to Pt B, Ch 7, App 1, based on the service loads of such machinery and equipment, as specified by the Designer.

In calculating these above service loads, the Designer is to take into account the inertial loads induced by ship motions in the most severe condition of use.

4 Other structures

4.1 Fore part

4.1.1 In general, a high freeboard is needed in the forward area, where most repair work is carried out, in order to provide adequate safety and protection against sea waves.

5 Hull outfitting

5.1 Equipment

5.1.1 Hawse pipes

Hawse pipes are to be integrated into the hull structure in such a way that anchors do not interfere with the cable laying.

5.1.2 Sheaves

Where there is a risk that, in rough sea conditions, sheaves are subjected to wave impact loads, special solutions such as the provision of retractable type sheaves may be adopted.

SECTION 3

MACHINERY AND SYSTEMS

1 General

1.1 Propulsion and manoeuvrability

1.1.1 The main propulsion systems of cable laying and/or repair ships are to be capable of:

- maintaining an adequate speed during the transit condition
- ensuring a satisfactory manoeuvrability at the speed assumed by the Designer for the performance of cable laying and/or repair operations.

1.2 Documents to be submitted

1.2.1 Tab 1 lists the documents which are to be submitted for information.

Table 1 : Documents to be submitted

No.	Document
1	General arrangement of the cable laying equipment
2	Design loads on all components of the cable laying equipment transferred to the ship structure
3	Structural plans of seating components of the cable laying equipment, including gears, pressure vessels, hydraulic systems, etc., as applicable, including details of the deck connection
4	Specification of the cable-laying equipment operation test

2 Arrangements for cable laying, hauling and repair

2.1 Typical machinery and equipment of cable laying ships

2.1.1 Cable laying ships, in relation to the special service to be performed, are generally to be provided with the following machinery and equipment:

- a main windlass for cable hauling or laying, which generally consists of a drum with a horizontal axis (the surface of which is formed by a series of timed conveyors which fleet the cable axially across the face of the drum) housing the repeaters fitted throughout the cable length without damaging them (see Fig 1 (a))
- a linear tensioner working in conjunction with the main windlass and fitted between it and the cable tank, which maintains the due tension of the cable in relation to the cable type so as to allow effective cable hauling or laying. In order to permit the passage of repeaters, the tensioner may be of the type having either a series of double opposed rubber tyres (see Fig 1 (b)) or pressure-compensated opposed tracks (see Fig 1 (c)).
- a dynamometer, normally fitted between the main windlass and the bow and stern sheaves, which continuously measures the force required to displace the cable under tension
- one or more cable transporters, used to move the cable from the tank(s) and the tensioner.

All the above machinery and equipment form the "cable laying or hauling line". More than one line may be fitted on board in the case of special service requirements.

Figure 1 : Cable handling machinery

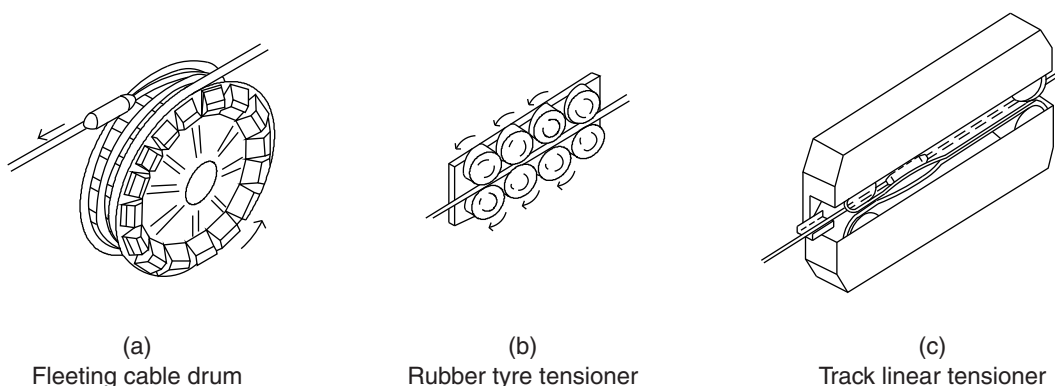

2.2 Design of cable handling machinery and equipment

2.2.1 The scantlings of components of machinery and equipment listed in [2.1] and, more generally, of any other machinery and/or equipment to be used for the laying, hauling or repair of submarine cables are outside the scope of classification.

2.3 Safety

2.3.1 The requirements of this Chapter are based on the assumption that during cable handling all necessary safety measures are taken, due consideration being given to risks connected with the use of machinery and equipment dealt with in [2.1] and that such machinery and equipment are properly used by skilled personnel.

2.4 Testing of cable handling machinery and equipment

2.4.1 General

Machinery covered by [2.1] is to be tested in compliance with the following requirements, with the exception of prime movers and “hydraulic accumulator” type pressure vessels, which are to be tested in compliance with the applicable requirements of the various Sections of the Rules.

2.4.2 Testing of materials and components of the machinery

- a) In general, testing is required for materials intended for shafts, gearing, pressure parts of pumps and hydraulic motors, and plates of foundations of welded construction.
- b) As far as mechanical tests of materials are concerned, internal shop testing certificates submitted by the Manufacturer may be accepted by the Society at its discretion; in such cases, testing operations witnessed by the Surveyor may be limited to visual external inspection associated, where necessary, with non-destructive examinations and hardness tests.

2.4.3 Hydrostatic tests

Pressure parts are to be subjected to hydrostatic tests in accordance with the applicable requirements.

2.4.4 Tests on electrical components

The tests required in Part C, Chapter 2 of the Rules are to be carried out as applicable.

2.4.5 Running tests

- a) Running tests of each individual piece of equipment are to be carried out whenever possible at the Manufacturer's works; as an alternative, the above tests may be performed on board during the trials required after installation of machinery.
- b) On completion and subject to the result of the above tests, the inspection of components may be required, with dismantling where deemed necessary by the Surveyor in charge of the testing.

3 On board trials

3.1 Ship trials

3.1.1

- a) Upon completion of construction, in addition to conventional sea trials, specific tests may be required at the Society's discretion in relation to the particular service for which the ship is intended or the particular characteristics of machinery and equipment fitted on board and according to a test specification submitted by the interested party.
- b) In particular, as far as propulsion and steering systems are concerned, tests may be required to check the manoeuvring capability and the speed of the ship whilst operating with only directional propellers or active rudders or a combination thereof.
- c) In the case of ships mainly intended for repair of submarine cables, a check of manoeuvring capability whilst running astern or a complete overturning trial may be required to be carried out using the rudder, active rudders or side thrusters only.
- d) In the case of ships provided with a dynamic positioning system, tests to check the capability of holding the desired position or heading are requested.

3.2 Equipment trials

3.2.1

- a) As far as arrangements for the cable laying, hauling and/or repair lines are concerned, tests are to be carried out to verify the proper operation of all relevant machinery and equipment, by means of the actual hauling and laying of submarine cables, plain or with repeaters, at different ship speeds and, if necessary, in different sea and weather conditions.
- b) Special attention is to be paid during such tests so as to prevent cables being forced to reach their minimum allowed bending radius, both inside and outside the ship.

SECTION 4

FIRE PROTECTION

1 Cable tanks

1.1 Means for fire fighting

1.1.1 Depending on any special requirements of the Manufacturers of cables, cable tanks may also be required to be protected by a fixed pressure water-spraying or automatic sprinkler fire-extinguishing system.

Part E
**Service Notations for
Offshore Service Vessels and Tugs**

Chapter 7

DIVING SUPPORT VESSELS

- SECTION 1 GENERAL**
- SECTION 2 GENERAL ARRANGEMENT**
- SECTION 3 STRUCTURAL ASSESSMENT**
- SECTION 4 MACHINERY AND SYSTEMS**
- SECTION 5 SAFETY FEATURES**
- SECTION 6 SPECIFIC REQUIREMENTS FOR SHIPS ASSIGNED WITH THE
SERVICE NOTATION DIVING SUPPORT-CAPABLE**
- SECTION 7 INITIAL INSPECTION AND TESTING**

SECTION 1 GENERAL

1 General

1.1 Application

1.1.1 Ships intended to support diving operations and complying with the present Chapter are eligible for the assignment of one of the following service notations as defined in Pt A, Ch 1, Sec 2, [4.8.4]:

- **diving support-integrated** when the vessel is fitted with permanently installed diving systems
- **diving support-portable**, when the vessel is fitted with a non-permanent diving system which is installed and operational
- **diving support-capable**, when the vessel is able to be fitted with a non-permanent diving system and the diving equipment is not installed.

Note 1: For non-permanent diving systems, the service notation **diving support-capable** is to be replaced by **diving support-portable** before conducting any diving operations (see Ch 7, Sec 6).

1.1.2 One of the following additional service features is to be added to service notations **diving support-integrated** and **diving support-portable**:

- **DD** when the diving system installed onboard is a deep diving system (or saturation system) as defined in [2.1.2]
- **SD** when the diving system installed onboard is a shallow diving system (or surface supplied diving system) as defined in [2.1.1].

Note 1: Bounce diving system as defined in [2.1.3] are considered as a shallow diving system for the purpose of this Chapter.

1.1.3 The present Chapter does not apply to the classification of diving systems which are covered by NR610, as detailed in [2.2].

1.1.4 Ships dealt with in this Chapter are to comply with:

- Part A of the Rules
- NR216 Materials and Welding
- applicable requirements according to Tab 1 and specific requirements for initial inspection and testing as per Ch 7, Sec 7.

Table 1 : Applicable requirements

Item		Greater than or equal to 500 GT	Less than 500 GT
Ship arrangement	L ≥ 65 or 90 m (1)	<ul style="list-style-type: none"> • Part B • Ch 7, Sec 2 (2) 	<ul style="list-style-type: none"> • NR566 • Ch 7, Sec 2 (2)
	L < 65 or 90 m (1)	<ul style="list-style-type: none"> • NR600 • Ch 7, Sec 2 (2) 	<ul style="list-style-type: none"> • NR566 • Ch 7, Sec 2 (2)
Stability		<ul style="list-style-type: none"> • Part B 	<ul style="list-style-type: none"> • NR566
Structural assessment	L ≥ 65 or 90 m (1)	<ul style="list-style-type: none"> • Part B • Ch 7, Sec 3 (2) 	<ul style="list-style-type: none"> • Part B • Ch 7, Sec 3 (2)
	L < 65 or 90 m (1)	<ul style="list-style-type: none"> • NR600 • Ch 7, Sec 3 (2) 	<ul style="list-style-type: none"> • NR600 • Ch 7, Sec 3 (2)
Machinery and systems		<ul style="list-style-type: none"> • Part C • Ch 7, Sec 4 (2) 	<ul style="list-style-type: none"> • NR566 • Ch 7, Sec 4 (2)
Electrical installations and automation		<ul style="list-style-type: none"> • Part C • Ch 7, Sec 4 (2) 	<ul style="list-style-type: none"> • NR566 • Ch 7, Sec 4 (2)
Safety features		<ul style="list-style-type: none"> • Part C • Ch 7, Sec 5 (2) 	<ul style="list-style-type: none"> • NR566 • Ch 7, Sec 5 (2)
<p>(1) Refer to the scope of application of NR600. (2) Or Ch 7, Sec 6 if the service notation diving support-capable is assigned. Note 1: NR566 : Hull Arrangement, Stability and Systems for Ships less than 500 GT. NR600 : Hull Structure and Arrangement for the Classification of Cargo Ships less than 65 m and Non Cargo Ships less than 90 m.</p>			

1.2 Scope

1.2.1 The present Chapter addresses the requirements regarding the installations on the supporting ship providing the diving system with auxiliary functions such as: fire safety, electrical power supply, communication means, breathing gas storage, ventilation, structural foundations, station keeping capabilities, etc.

1.2.2 The present Chapter includes the provisions of IMO Code of Safety for Diving Systems as applicable to the interface between the diving system and the supporting ship.

Note 1: Attention is drawn to the fact that IMO Code of Safety for Diving Systems also covers the diving system itself.

These requirements are reproduced in *Italic type*. In reproducing the text, the word “Administration” is replaced by the word “Society”.

2 Diving system

2.1 Description

2.1.1 Shallow or surface supplied diving system

A surface supplied diving system is a system where interventions by divers are performed at such depth and durations that the descent onto the seabed, the work and the decompression are carried out in the water (without resorting to the use of a closed diving bell).

The breathing gas is supplied from the supporting vessel through an umbilical.

The breathing gas may be:

- pure compressed air, or
- mixed gas with enriched oxygen or helium.

The surface supplied diving installation generally includes as the case may be:

- means of getting into water
- means to recover the divers
- a decompression chamber
- means adapted to the diving method used.

2.1.2 Deep or saturation diving system

A saturation diving system is a system where the divers live in a pressurized environment which may be maintained for several days or weeks. Divers are generally decompressed to surface pressure only once, at the end of their tour of duty.

2.1.3 Bounce diving system

For the purpose of the present Chapter, a bounce diving system, as defined in [3.2.2], is considered as a shallow diving system.

2.1.4 Components of the diving system

Diving systems generally include, but are not limited to, the items listed in Tab 2.

Table 2 : List of diving equipment

Items	Deep diving	Shallow diving
Submersible compression chamber (closed diving bell)	X	
Wet diving bell or diver basket		X
Deck decompression chamber	X	X
Deck decompression chamber control panel	X	X
Hyperbaric evacuation system	X	
Breathing supply system	X	X
Handling systems for the diving bell	X	X
Diving control stand	X	X
Clamping and under pressure transfer system	X	
Devices for controlling the atmosphere	X	X
Devices for the recovery and the purification of breathing gases	X	X
Means of production of hot water	X	X

2.2 Classification of the diving system

2.2.1 The diving system is to be classed and compliant with NR 610 Rules for the Classification of Diving Systems, or with the rules of a recognized Classification Society.

As an alternative, a recognized diving system certificate may be accepted, subject to the Society agreement.

2.2.2 Classification of the diving support ship and classification of the diving system are independent.

3 References

3.1 Acronyms

3.1.1 The following acronyms are used:

DDC : Deck decompression chamber (see [3.2.5])

HRU : Hyperbaric rescue unit (see [3.2.11])

LARS : Launch and recovery system (see [3.2.12])

MSW : Metres of sea water (see [3.2.15])

SDC : Submersible diving chamber (see [3.2.4])

SPHL : Self-propelled hyperbaric lifeboat (see [3.2.11]).

3.2 Definitions

3.2.1 Bottle

Pressure container for the storage and transport of gases under pressure. Also called gas cylinders.

3.2.2 Bounce diving system

A bounce diving system is a system using a closed diving bell and where the divers are decompressed on-board in a deck decompression chamber after each dive.

3.2.3 Breathing gas

All gases and mixtures of gases which are used for breathing during diving operations.

3.2.4 Closed diving bell / submersible diving chamber

Manned underwater compression chamber, including its fitted equipment, for transfer of diving personnel under pressure between the work location and the deck chambers.

Also known as a personnel transfer capsule (PTC) or submersible compression chamber or submersible diving chamber (SDC).

3.2.5 Deck decompression chamber (DDC)

Pressure vessel for human occupancy which does not go under water and may be used as a living chamber during saturation diving, diver decompression or treatment of decompression illness. Also called compression chamber, recompression chamber, deck chamber or surface compression chamber.

3.2.6 Depth

Water depth or equivalent pressure to which the diver is exposed at any time during a dive or inside a surface compression chamber or a diving bell.

3.2.7 Diving basket

Man-riding equipment used for transfer of diving personnel at ambient sea pressure between the work location and the diving support ship.

3.2.8 Hazardous areas

Those locations in which an explosive gas-air mixture is:

- continuously present, or present for long periods (zone 0)
- likely to occur in normal operation (zone 1)
- not likely to occur and, if it happens, only existing for a short time (zone 2).

3.2.9 Hyperbaric evacuation system (HES)

The whole plant and equipment necessary for the evacuation of divers in saturation from a deck decompression chamber to the Hyperbaric Reception Facility (HRF) where decompression can be carried out. The main components of a hyperbaric evacuation system include the Hyperbaric Rescue Unit (HRU), its handling system, the Hyperbaric Reception Facility and the evacuation procedures.

3.2.10 Hyperbaric reception facility (HRF)

Normally a shore based facility (but could be installed off-shore) which is capable of accepting a HRU and mating it to a decompression chamber such that the evacuated occupants can be transferred into that chamber and safely decompressed.

3.2.11 Hyperbaric rescue unit (HRU)

Floating unit used to evacuate divers under pressure safely from a ship or a floating structure to a location where decompression can be carried out.

It may be a Hyperbaric Rescue Chamber (HRC) or a Self-Propelled Hyperbaric Lifeboat (SPHL). Also known as Hyperbaric Evacuation Unit (HEU).

3.2.12 Launch and recovery system (LARS)

Plant and equipment necessary for raising, lowering and transporting the diving bell, and/or diving basket, between the work location and the surface compression chamber.

3.2.13 Life support system

Gas supply, breathing gas system, decompression equipment, environmental control system and equipment required to provide a safe environment for the diving crew in the diving bell and the surface compression chamber under all ranges of pressure and conditions they may be exposed to during diving operations.

3.2.14 Maximum operating depth

Depth in metres of seawater equivalent to the maximum pressure for which the diving system is designed to operate.

3.2.15 Metres of sea water (MSW)

Metres of sea water are sometimes used to express a water depth equivalent to a pressure. For the purpose of the design and testing of pressure vessels, the values in MSW are to be converted into pressure units.

3.2.16 Portable diving systems

Portable equipment not remaining onboard but installed periodically for the purpose of specific works related to diving.

3.2.17 Pressure vessel

Container capable of withstanding an internal maximum working pressure greater than or equal to 1 bar.

3.2.18 Umbilical

Link between the diving support ship and the diving bell, or link between the diving bell and divers

It may contain surveillance, communication and power supply cables, breathing gas and hot water hoses.

3.2.19 Wet diving bell / open diving bell

Bell with a closed top section, capable of containing a dry gaseous atmosphere to provide a refuge for the divers. It is not a pressure vessel. Also called an open bell.

3.3 Reference rules and regulations

3.3.1 The requirements of the present Chapter are generally consistent with the following rules and regulations:

- IMO - Code of Safety for Diving System:
IMO - Code of Safety for Diving Systems means the Code of Safety adopted by IMO Resolution A.831(19), as amended.
- IMO - Guidelines and Specifications for Hyperbaric Evacuation Systems:
IMO Guidelines and Specifications for Hyperbaric Evacuation Systems adopted by Resolution A.692(17).
- IMCA publications:
International Marine Contractors Association (IMCA) is the editor of various publications providing guidelines for commercial diving and dynamic positioning operations. The following IMCA publications are referenced within the present Chapter:

- IMCA D 014 - IMCA international code of practice for offshore diving
- IMCA D 018 - Code of practice on the initial and periodic examination, testing and certification of diving plant and equipment
- IMCA D 039 - FMEA guide for diving systems
- IMCA D 052 - Guidance on hyperbaric evacuation systems
- IMCA AODC 055 - Protection of water intake points for diver safety.

4.2 Diving system documentation

4.2.1 Specification

The diving system specification is to include:

- the description of the system
- a design basis including:
 - maximum operating depth (and equivalent design pressure)
 - maximum operating time
 - maximum number of divers in water and in the DDC
 - maximum time of occupancy expected in the DDC
 - maximum operational wave height
 - minimum and maximum sea and air temperature
 - safety concept.
- the list of diving equipment with reference and name of the manufacturer.

4 Documents to be submitted

4.1 General

4.1.1 The documents listed in Tab 3 are to be submitted.

Table 3 : Documents to be submitted

No.	Documents to be submitted	I/A (1)
1	Diving system documentation (2): <ul style="list-style-type: none"> • diving system certificates • specification (see [4.2.1]) • operating manual (see [4.2.2]) • equipment and certificate register (see [4.2.3]) • service record book (see [4.2.4]) • FMEA (see [4.2.5]) and critical spare parts list • planned maintenance system (see [4.2.6]) 	I
2	General arrangement of the ship showing the diving system arrangement and including the: <ul style="list-style-type: none"> • locations of equipment • location of breathing gas storage • hazardous zone and hazardous substances locations • interface with the piping arrangement, electrical installations, etc. 	A
Structural assessment		
3	Structural arrangement showing the interface between diving equipment and hull structure	A
4	Description of the seafastening, if any	I
Electrical installations		
5	General arrangement showing location of electrical installations	I
6	Description of electrical arrangement principles, failure scenarios, redundancy principles, emergency arrangement, etc.	I
7	Single line distribution diagram and detailed diagram of the whole installation	A
8	General arrangement of the diving control room	A
9	Descriptions and details of any communication means as required by the Rules, including single line diagram	A
10	Description and details of the lighting arrangement around the diving system	A
Safety features		
11	Fire protection documentation with definition of the spaces which enclose or surround the diving system items and details of the passive fire protection	A
12	Fire-fighting equipment details	A
13	Fire detection and alarm equipment details	A
14	Breathing gas arrangement details, including piping diagram	A
15	General arrangement showing the hyperbaric evacuation means	A
(1) A : For approval I : For information.		
(2) Except when not available in case of service notation diving support-capable .		

4.2.2 Operating manual

The manufacturer of the diving equipment is to provide an operating manual with detailed information on the method to use the decompression system.

- the user instructions to operate the system
- operational limitations
- evacuation procedure

4.2.3 Equipment and certificate register

An equipment and certificate register as defined in IMCA D014 is to be kept on-board.

4.2.4 Service record book

The Owner is to establish and maintain a service record book of the diving system which is to be submitted to the Society for in-service inspections.

The service record book is to contain all service and maintenance operations.

The service record book is to be available on-board.

4.2.5 Failure modes and effects analysis (FMEA)

A failure modes and effects analysis (FMEA) of the diving installation is to be conducted at an early stage of the new

built projects or when a portable diving system is to be installed on-board.

The FMEA should identify the critical components for which spare parts should be provided.

It is recommended to update the FMEA for each modification of the diving system.

Note 1: A guidance to conduct to FMEA is proposed in the document IMCA D039 - FMEA guide for diving systems.

4.2.6 Planned maintenance system (PMS)

A planned maintenance system (PMS), as defined in IMCA D 018, should be submitted to the Society.

The PMS should include the requirements for the periodic examinations and testing.

The PMS should ensure the traceability of the maintenance works carried out and the routine replacement of the components on the diving plant.

The PMS is to include the identification markings of the diving equipment.

SECTION 2

GENERAL ARRANGEMENT

1 General arrangement

1.1 Diving system arrangements

1.1.1 *The diving system and breathing gas facilities should be arranged in spaces or locations which are adequately ventilated and provided with suitable electric lighting.*

1.1.2 *When any part of the diving system is sited on open deck, particular consideration should be given to providing reasonable protection from the sea, icing, heat or any damage which may result from other activities on board the ship or floating structure.*

1.1.3 *Diving systems are not to be located closed to ventilation outlets and exhausts from machinery spaces or galleys.*

Note 1: In general, a minimum distance of 6 metres between ventilation outlets or exhausts defined above, and diving system ventilation inlets is considered sufficient.

1.1.4 The diving system arrangement is to comply with the safety features requirements in Ch 7, Sec 5.

1.2 Machinery spaces

1.2.1 *The diving system and breathing gas storage facilities shall not be located in machinery spaces if the machinery is not associated with the diving system.*

1.3 Hazardous areas

1.3.1 As far as practicable, diving systems should not be located in hazardous areas.

1.3.2 Where, due to the requirements of diving operations, the diving equipment is located in hazardous areas zone 1 or zone 2, it has to comply with the requirements for such equipment in hazardous areas, as defined Part C, Chapter 4

1.3.3 *In any case, diving equipment are not permitted in hazardous areas designated as zone 0.*

1.4 Breathing gas storage

1.4.1 Particular requirements apply to the storage of the breathing gas, as specified in Ch 7, Sec 5.

1.5 Location of deck decompression chamber

1.5.1 It is recommended to install deck decompression chambers in the longitudinal direction to limit the effect of rolling motion on the divers.

1.5.2 The deck decompression chamber of a surface supplied diving system is to be close to the location where the diver is getting out of the water and easily accessible without any trip hazards.

1.6 Diving operations

1.6.1 The diving system is to be located in such a way that diving operations are not affected by thrusters, propellers or mooring lines.

1.6.2 The diving operation arrangement should ensure that all deployed umbilicals are physically prevented from coming into contact with any hazard such as thrusters or seawater inlets.

2 Access arrangement

2.1 General

2.1.1 There is to be a sufficient level of access available around the diving system in order to allow operational personnel to safely and efficiently carry out their duties.

2.2 Means of evacuation

2.2.1 An hyperbaric evacuation system is to be provided for units granted with the additional service feature **DD**, as specified in Ch 7, Sec 5.

SECTION 3

STRUCTURAL ASSESSMENT

1 Diving equipment foundations

1.1 General

1.1.1 *Provision should be made to ensure that the diving system and auxiliary equipment are securely fastened to the ship or floating structure and that adjacent equipment is similarly secured. Consideration should be given to the relative movement between the components of the system. In addition, the fastening arrangements should be able to meet any required survival conditions of the ship or floating structure.*

1.1.2 Diving equipment are to be permanently secured to the ship primary structure by means of welding or bolting. Normally, a lashing arrangement is considered as not sufficient.

1.1.3 The fastening arrangement of the pressure vessel has to allow volume variations due to internal pressure variations.

1.2 Design loads

1.2.1 The deadweight and the maximum operational loads of the diving equipment are to be provided (maximum number of persons, stores and equipment).

1.2.2 The design loads of pressure vessels for human occupancy are to be especially considered if hydro testing is to be made onboard.

1.3 Allowable deflection

1.3.1 The deflection of the deck in way of the deck decompression chamber are to be within the allowable limits set by the equipment manufacturer, if any.

2 Launching system foundations

2.1 General

2.1.1 The foundations of the launching appliance are to comply with Pt B, Ch 1, Sec 1, [1.2].

SECTION 4

MACHINERY AND SYSTEMS

1 Sea inlets

1.1 General

1.1.1 Special considerations are to govern the design of sea inlets fitted in the hull of the ship, in order to protect the divers and the unit seawater systems.

Note 1: Recommendations are provided in IMCA AODC 055.

1.1.2 Water current in the immediate vicinity of the sea inlet is not to exceed 0,5 m/sec.

1.1.3 The mesh or aperture size of any protective structure is to be such as to prevent any part of the diver or his equipment from being drawn into the intake.

1.1.4 The maximum mesh size, or the maximum size of any opening if not a mesh-type construction, is not to exceed an area of 400 cm², equivalent to a square of 20 cm x 20 cm or a rectangle of 28 cm x 14 cm.

2 Position keeping

2.1 General

2.1.1 Ships covered by the present Chapter are to be able to safely maintain their position during diving operations. This may be achieved with a passive mooring or a dynamic positioning system complying with [2.2].

2.2 Dynamic positioning

2.2.1 When a diving support unit is fitted with a dynamic positioning system used during diving operations, the dynamic positioning system is to comply with IMO class 2 requirements.

In this case, the diving support unit is to be granted with the additional class notation **DYNAPOS AM/AT**, completed by one of the following symbols:

- **R**, when the dynamic positioning is provided with redundancy means. In this case, IMO class 2 equipment is to be used.
- **RS**, when, in addition to symbol **R**, the redundancy is achieved using two systems or alternative means of performing a function physically separated. In this case, IMO class 3 equipment is to be used.

2.2.2 The dynamic positioning control stand and the diving control room are to have 2-way communication means and a manually operated alarm.

3 Electrical installations

3.1 General

3.1.1 *All electrical equipment and installations, including power supply arrangements, should be designed for the environment in which they will operate in order to minimize the risk of fire, explosion, electrical shock and emission of toxic gases to personnel, as well as galvanic corrosion of the deck decompression chamber or diving bell.*

3.1.2 Electrical installations of the diving system are to be considered as secondary essential services according to Pt C, Ch 2, Sec 1.

3.1.3 Main and automatic emergency lightings are to be provided in spaces containing diving equipment.

3.1.4 Electrical wires are to be separated from piping installations carrying breathing gas.

3.2 Electrical power supply

3.2.1 *In the event of failure of the main source of electrical power supply to the diving system, an independent source of electrical power is to be available for the safe termination of the diving operation. It is admissible to use the unit's emergency source of electrical power as an emergency source of electrical power if it has sufficient electrical power capacity to supply the diving system and the emergency load for the vessel at the same time.*

3.2.2 *The alternative source of electrical power is to be located outside the machinery casings to ensure its functioning in the event of fire or other casualty causing failure to the main electrical installation.*

3.2.3 As a minimum, the emergency source of power is to be of sufficient capacity to supply:

- the life support system (analysis and regeneration)
- the emergency communication system
- the emergency lighting in the deck decompression chamber, the diving bell and the diving control room
- the LARS
- the handling system required for emergency launching of the means of hyperbaric evacuation
- the emergency systems in the diving control room.

3.2.4 The emergency source of power is to be capable of supplying the systems specified in [3.2.3] for a period in compliance with the National Authorities' regulations, as relevant, and in any case not less than 18 hours.

3.2.5 When switching from the main source of power to the emergency source of power, an audible and visible alarm is to be actuated in the diving control room with the indication of the source of power connected.

4 Diving control station

4.1 General

4.1.1 *The diving system should be so arranged as to ensure that centralized control of the safe operation of the system can be maintained under all weather conditions.*

4.1.2 The diving control station is to provide control of diving operations and of hyperbaric chambers.

These functions may be separated in 2 distinct control rooms with suitable means of communication.

4.2 Communication and relocation system

4.2.1 The communication system should be arranged for direct 2-way communication between the diving control station(s) and:

- the deck decompression chamber control stand, when relevant
- the divers in water

- the diving bell
- each compartment of the deck decompression chamber
- the handling system operating position
- the dynamic positioning control stand
- the bridge
- the hyperbaric evacuation system launch point
- inside the hyperbaric evacuation system.

4.2.2 *Alternative means of communication with divers in the deck decompression chamber and submersible compression chamber should be available in case of emergency.*

4.2.3 *Each deck decompression chamber and submersible compression chamber should be connected to a speech unscrambler when used with gas systems, including helium.*

5 Diver heating system

5.1 Oil fired heaters

5.1.1 When diver heating system includes oil fired heaters, they are to be located such that they present no risk to the dive system in the event of fire.

5.1.2 The local tank is to be fitted with an overflow system with a capacity greater than the filling supply system (i.e. capable of allowing a rate of overflow greater than the filling rate).

5.1.3 The overflow system is to dump to a safe area.

SECTION 5

SAFETY FEATURES

1 Fire safety

1.1 Personnel protection

1.1.1 As a minimum, the following fire protection equipment is to be provided in the diving control room for all persons required for the safe operation of the diving equipment, in addition to individual equipment required by the SOLAS Convention:

- emergency breathing masks
- fire-fighter's outfits.

1.2 Structural fire protection

1.2.1 All materials and equipment used in connection with the diving system should be, as far as practicable, of fire-retardant type in order to minimize the risk of fire and sources of ignition.

1.2.2 Enclosed spaces in which the diving system or its auxiliary equipment is located are to be provided with structural fire protection A-60 with adjacent spaces.

These enclosed spaces may be subdivided into several compartments containing diving equipment and separated with A-0 bulkheads.

1.2.3 Doors located in bulkheads forming boundaries with adjacent spaces are to be of self-closing type.

1.2.4 Piping and cables included in the diving system are to be routed in ducts having the same fire protection than the space containing the diving equipment.

1.3 Detection and alarm

1.3.1 *Interior spaces containing diving equipment such as deck decompression chambers, submersible compression chambers, gas storage, compressors and control stands are to be provided with an automatic fire detection and alarm system.*

1.3.2 The fire detection and alarm system referred to in [1.3.1] is to be independent of those of the other spaces.

1.3.3 The fire detection panel is to be located in the ship control station and repeated in the engine control room and diving control station(s).

1.4 Fire-fighting equipment

1.4.1 *Interior spaces containing diving equipment such as deck compression chambers, submersible compression chambers, breathing gas storage, compressors and control stands are to be provided with a suitable fixed fire-extinguishing system.*

1.4.2 The fixed fire-extinguishing system is to be a water spraying system manually actuated and complying with the IMO International Code for Fire Safety Systems (FSS Code) for machinery space of category A.

1.4.3 An equivalent gas fire-extinguishing system using a non-toxic gas as specified in the FSS Code may be provided subject to the Society approval.

1.4.4 *When pressure vessels (including gas cylinders) are situated in enclosed spaces, a manually actuated water spray system having an application rate of 10 litres per minute per square metre of the horizontal projected area is to be provided to cool and protect such pressure vessels in the event of an external fire.*

Alternative means using water mist may be provided subject to the Society approval.

1.4.5 Means for cooling windows of pressure vessels for human occupancy are to be provided.

1.4.6 *When pressure vessels are situated on open decks, fire hoses may be considered as providing the necessary protection.*

1.4.7 *Portable fire extinguishers of approved types and designs are to be distributed throughout the space containing the diving system.*

1.4.8 *One of the portable fire-extinguishers is to be stowed near the entrance to that space.*

1.4.9 Spare charges for portable fire-extinguishers are to be provided on board as specified below:

- 100% for the first ten fire-extinguishers
- 50% for the remaining fire-extinguishers installed in the enclosed space.

2 Breathing gas system

2.1 Storage on board

2.1.1 Breathing gas storage and associated equipment should not be located in a machinery space not associated with the diving system.

2.1.2 As a rule, breathing gas should be stored on an open deck.

2.1.3 If the breathing gas is located in an enclosed space, the following is to be provided:

- a forced ventilation system as defined in [3]
- a type approved continuous monitoring system of the oxygen content in the ambient air
- a type approved audio-visible oxygen alarm (low-high) is to be installed at a manned control station
- any relief valve or bursting disc is to be piped to dump overboard and not into the enclosed space
- the enclosed space is to be gas-tight
- if lighting is provided in the enclosed space containing the breathing gas, it is to be of an approved safe type for operation in the gases likely to be encountered
- signboards as defined in [2.5].

2.1.4 Breathing gas should not be stored near flammable substances.

2.1.5 Any gas mixture containing more than 25% oxygen by volume will need to be handled like pure oxygen.

2.2 Piping

2.2.1 Piping containing breathing gas under high pressure is not to be arranged inside the accommodation spaces, machinery spaces or hazardous areas.

2.2.2 Piping systems containing flammable substances are not to be arranged in the same area as piping systems containing breathing gas.

2.2.3 Flexible hoses, except for umbilicals, should be reduced to a minimum.

2.2.4 Exhaust lines should be fitted with an anti-suction device on the inlet side.

2.2.5 Gases vented from the diving system should be vented into the open air away from sources of ignition, personnel or any area where the presence of those gases could be hazardous.

2.2.6 All high-pressure piping is to be protected against mechanical damage.

Note 1: Generally piping is considered under high pressure between cylinders or compressors and pressure reducing devices.

2.2.7 Piping carrying breathing gas is to be kept away from electrical cables.

2.3 Oxygen installation

2.3.1 A recognized standard is to be applied for the design of the oxygen installation and submitted to the Society for approval.

2.3.2 Any material used in a plant which is intended to carry oxygen is to be compatible with oxygen at working pressure and flow rate.

2.3.3 The use of high-pressure oxygen piping is to be minimized by the fitting of pressure reducing devices, as close as practicable to the storage cylinders.

2.3.4 Means of protection against overpressure are to be provided in accordance with Pt C, Ch 1, Sec 10, [2]

2.3.5 Hoses for oxygen are to be of fire-retardant construction and type-approved.

2.3.6 Any materials used in a plant which is intended to carry oxygen is to be cleaned of hydrocarbons and debris to avoid explosions. Formal cleaning procedures for such equipment are to be developed and implemented.

2.4 Colour code

2.4.1 For piping systems and gas storage bottles/pressure vessels, the colour codes defined in Tab 1 are to be used.

In addition, each bottle/pressure vessel is to be marked with the name and symbol of the gases it contains. The marking and colour coding of the gas storage bottles is to be visible from the valve end.

Table 1 : Colour code

Name	Symbol	Colour code
Oxygen	O ₂	white
Nitrogen	N ₂	black
Air	Air	white and black
Carbon dioxide	CO ₂	grey
Helium	He	brown
Oxygen-helium mix gas	O ₂ -He	white and brown

2.5 Signboards

2.5.1 As a minimum, the following signboards are to be displayed in the storage room containing breathing gas:

- NO SMOKING
- diagram of the breathing gas plant.

3 Ventilation

3.1 General

3.1.1 Enclosed spaces containing the diving equipment are to have a forced ventilation with a rate of 8 air changes per hour with an independent system. The air intake is to be located in a non-hazardous area.

3.1.2 Ventilation fans are to be of non-sparking construction complying with Pt C, Ch 4, Sec 1.

4 Means of evacuation of the divers in saturation

4.1 Application

4.1.1 Ships having the additional service feature **DD** are to be provided with an hyperbaric evacuation system.

4.2 Hyperbaric evacuation system

4.2.1 *An evacuation system is to be provided having sufficient capacity to evacuate all divers under pressure in the event of the ship having to be abandoned.*

4.2.2 *The hyperbaric evacuation system is to comply with the IMO "Guidelines and Specifications for Hyperbaric Evacuation Systems", adopted by resolution A.692(17).*

4.3 Launching arrangement

4.3.1 The hyperbaric evacuation system launching arrangement is to be manufactured, inspected and tested according to SOLAS and IMO International Life-Saving Appliances Code (LSA Code) requirements, as far as practicable.

SECTION 6

SPECIFIC REQUIREMENTS FOR SHIPS ASSIGNED WITH THE SERVICE NOTATION DIVING SUPPORT-CAPABLE

1 General

1.1 Application

1.1.1 The present Section provides requirements for ships intended to be fitted with non-permanent diving systems.

1.1.2 Ships complying with the present Section are eligible for the assignment of the service notation **diving support-capable** defined in Ch 7, Sec 1, [1.1.1].

1.1.3 Provisions and margins for the diving system are to be considered in the design of the supporting ship. The documents to be submitted are listed in [1.2].

1.1.4 The service notation diving support-capable apply when the diving system is not installed on board.

1.1.5 When the diving system is installed on board and before diving operations, the service notation **diving support-portable** is to be activated in replacement of **diving support-capable**, as detailed in [1.3].

1.2 Documents to be submitted

1.2.1 General

The documents listed in Tab 1 are to be provided, as a minimum. Any additional information deemed necessary may be required by the Society.

Table 1 : Documents to be submitted

No.	Documents to be submitted	I/A (1)
1.1	Diving operational restrictions (Maximum MSW, limiting environmental conditions, ...)	I
1.2	Provisional characteristics of the diving system: <ul style="list-style-type: none"> • list of equipment • mass estimated • overall dimensions and arrangement • electrical consumers list • quantity of divers 	I
1.3	General arrangement of the ship showing the provisions for diving system arrangement and including the: <ul style="list-style-type: none"> • locations of equipment • location of breathing gas storage • hazardous zones and hazardous substances locations • interface with the piping arrangements, electrical installations, etc. 	A
1.4	Description of the interface between the diving system and the supporting ship as detailed in [1.2.2]	I
Structural assessment		
2.1	Structural arrangement showing the interface between diving equipment and hull structure	A
Electrical installations		
3.1	Description of electrical arrangement principles, when relevant	I
3.2	Electrical balance of the ship considering the diving system	A
Safety features		
4.1	Fire protection documentation with definition of the spaces which enclose or surround the diving system items and details of the passive fire protection, when relevant (2)	A
4.2	Fire-fighting equipment details	A
4.3	Fire detection and alarm equipment details, when relevant	A
4.4	Breathing gas arrangement details including piping diagram, when relevant	A
(1) A : For approval I : For information.		
(2) Not applicable to open deck		

1.2.2 Description of the interface between the diving system and the supporting ship

A description of the interface with the supporting ship is to be provided, including the modifications to be made on the ship where necessary.

The description is to include:

- the electrical power supply
- the fresh water supply
- the sea water supply
- the means for fire fighting, when provided by the ship
- the means of communication and alarms between the bridge of the ship and:
 - the diving control station,
 - the life support control station,
 - the LARS control stand.

1.3 Activation of service notation diving support-portable

1.3.1 Before any diving operation being conducted, the service notation **diving support-portable** is to be activated. For this purpose, the following requirements are to be complied with:

- documents defined in Ch 7, Sec 1, [4] are to be submitted for information or approval, including a recognized certificate of the diving system, as per Ch 7, Sec 1, [2]
- a survey of the diving system is to be conducted after the installation of the diving equipment on board, as defined in Ch 7, Sec 7, [1.2].

1.3.2 When the requirements of [1.3.1] are fulfilled, the class certificate of the supporting ship is re-issued with the service notation **diving support-portable**, in replacement of **diving support-capable**.

Note 1: Normally, a minimum of 4 weeks is to be scheduled between the submission of the documents to the Society and the diving operations.

2 General arrangement

2.1 General

2.1.1 Applicable requirements of Ch 7, Sec 2 are to be complied with, based on the provisional characteristics of the diving system.

3 Structural assessment

3.1 General

3.1.1 Requirements of Ch 7, Sec 3 are to be complied with, based on the provisional characteristics of the diving equipment.

4 Machinery and systems

4.1 Position keeping

4.1.1 Requirements of Ch 7, Sec 4, [2] are to be complied with.

4.2 Sea inlets

4.2.1 Relevant requirements of Ch 7, Sec 4, [1] are to be complied with.

5 Electrical installations and automations

5.1 Electrical power supply

5.1.1 When the electrical power is supplied by the supporting ship, applicable requirements of Ch 7, Sec 4, [3] are to be complied with.

6 Safety features

6.1 Fire safety

6.1.1 When a part of the diving system is located in an enclosed space inside the supporting ship, applicable requirements of Ch 7, Sec 5, [1] are to be complied with.

6.2 Breathing gas facilities

6.2.1 Applicable requirements of Ch 7, Sec 5, [2] are to be complied with, based on the provisional characteristics of the diving system.

6.3 Ventilation

6.3.1 When a part of the diving system is located in an enclosed space inside the supporting ship, applicable requirements of Ch 7, Sec 5, [3] are to be complied with.

SECTION 7

INITIAL INSPECTION AND TESTING

1 General

1.1 Application

1.1.1 The present Section provides requirements for initial inspection and testing of the diving equipment when first installed on-board or after re-installation on a supporting ship.

1.1.2 Upon the installation of the diving system on-board and in addition to conventional sea trials, specific inspection and testing in relation to the particular service for which the ship is intended are required.

1.1.3 These tests are to be conducted according to an inspection and testing specification to be submitted to the Society by the party applying for classification.

The Society is to be duly informed of the time and place of the commissioning tests of the diving system.

1.1.4 The commissioning procedures of the diving system should be approved by the certifying authority of the diving system.

1.1.5 The inspection and testing requirements of the present Section are provided as a minimum and in addition to the requirements of the rules or standards referred to in the diving system certificate.

Any additional testing may be required to the satisfaction of the attending Surveyor.

1.1.6 The Factory Acceptance Tests (FAT) of the diving equipment are not in the scope of the present Chapter.

1.2 Non-permanent diving system

1.2.1 Non-permanent diving systems should meet inspection and testing requirements defined in [2] after each installation on-board.

1.2.2 Upon satisfactory completion of [1.2.1], the service notation **diving support-portable** may be activated as defined in Ch 7, Sec 6, [1.3].

2 On-board testing

2.1 Diving installations

2.1.1 The inspection and testing of the diving installation should include, as a minimum:

- a) Verification of the presence on-board of the following documents:
 - Diving system specification, as defined in Ch 7, Sec 1, [4.2.1]
 - Operating manual, as defined in Ch 7, Sec 1, [4.2.2]
 - Equipment and certificate register, as defined in Ch 7, Sec 1, [4.2.3]
 - Planned maintenance system, as defined in Ch 7, Sec 1, [4.2.6].
- b) Verification of the structural arrangement and scantling of the foundations of pressure vessels and bell handling system
- c) Verification of the sea fastening arrangement of the diving equipment. If the sea fastening requires any welded fixtures then there is to be Non Destructive Testing reports available confirming these welds were satisfactorily tested
- d) Functional testing of the main source of electrical power, emergency source of electrical power and switching from one to the other. Verification of the satisfactory operation of the alarms and indications
- e) General examination of the electrical cabling
- f) Functional testing of the main and alternative two-way communication system at the dive location, i.e. between divers, chambers, control rooms, launch point and other important locations
- g) Testing of the breathing gas installations:
 - 1) general examination of the storage of the gas cylinders
 - 2) verification of cleanliness of the breathing gas piping system according to the approved procedure
 - 3) testing of the gas-tightness of all sealing devices of the enclosed spaces for breathing gas storage
 - 4) confirmation of the proper operation of the forced ventilation of the enclosed spaces for gas storage
 - 5) verification of the means for the protection against overpressure of the oxygen installation
 - 6) verification of the alarms of oxygen-measuring equipment
 - 7) verification of the signboards in the area containing the gas cylinders.
- h) General examination of the automatic fire detection and alarm system
- i) Verification of the suitable fixed fire-extinguishing system intended for interior spaces containing diving equipment

- j) Confirmation that the fire fighters' outfits, including their self-contained compressed air breathing apparatus, two-way portable communication apparatus and emergency breathing mask, are complete and in good condition and that the cylinders, including the spare cylinders, of any required self-contained breathing apparatus are suitably charged
- k) Functional testing of the self closing systems of the doors located in the bulkheads forming boundaries with the adjacent spaces
- l) General examination of the visible parts of the items forming the structural fire protection, such as bulkheads, decks, doors and trunks, due attention being given to their integrity and that of the insulating material.

2.1.2 As a rule, all the connections between the supporting ship and the diving installation are to be presented for examination by the Surveyor.

Part E
**Service Notations for
Offshore Service Vessels and Tugs**

Chapter 8
LIFTING UNITS

SECTION 1	GENERAL
SECTION 2	GENERAL ARRANGEMENT
SECTION 3	STABILITY AND SUBDIVISION
SECTION 4	STRUCTURAL ASSESSMENT
SECTION 5	MACHINERY AND SYSTEMS
SECTION 6	INITIAL INSPECTION AND TESTING
SECTION 7	SELF-ELEVATING SHIPS

SECTION 1

GENERAL

1 General

1.1 Application

1.1.1 Ships complying with the present Chapter are eligible for the assignment of the service notation **lifting** as defined in Pt A, Ch 1, Sec 2, [4.9.6].

1.1.2 Ships dealt with in this Chapter are to comply with:

- Part A of the Rules
- NR216 Materials and Welding
- applicable requirements according to Tab 1 and specific requirements for initial inspection and testing as detailed in Ch 8, Sec 6.

1.1.3 The lifting appliance is to be certified as required in [2.1].

1.1.4 Ships fitted with legs for self-elevating purposes

When the vessel is fitted with legs for self-elevating purpose, the additional service feature self-elevating is to be assigned in accordance with Pt A, Ch 1, Sec 2, [4.9] and the requirements of Ch 8, Sec 7 are to be complied with.

1.2 Scope

1.2.1 The present Chapter addresses the requirements regarding the installations on the ship providing the lifting equipment with auxiliary functions (power supply, communication

means, station keeping capabilities etc.), the stability criteria for lifting operations and the requirements for the structural assessment of the foundations of the lifting equipment.

1.2.2 Specific requirements for ships fitted with legs for self-elevating purposes are also addressed in Ch 8, Sec 7.

2 Lifting equipment

2.1 Certification of the lifting equipment

2.1.1 The lifting equipment is to be certified and included within the scope of classification by assigning to the lifting unit the additional class notation **ALM** or **OHS**, as defined in Pt A, Ch 1, Sec 2, [6.12] and Pt A, Ch 1, Sec 2, [6.14.34] respectively.

3 References

3.1 Acronyms

3.1.1 The following acronyms are used:

- DAF : Dynamic amplification factor (see [3.2.1])
 MBL : Minimum breaking load (see [3.2.4])
 RP : Rated line pull (see [3.2.6])
 SWL : Safe working load (see [3.2.7])
 WLL : Working load limit (see [3.2.9]).

Table 1 : Applicable requirements

Item		Greater than or equal to 500 GT	Less than 500 GT
Ship arrangement	L ≥ 65 or 90 m (1)	<ul style="list-style-type: none"> • Part B • Ch 8, Sec 2 	<ul style="list-style-type: none"> • NR566 • Ch 8, Sec 2
	L < 65 or 90 m (1)	<ul style="list-style-type: none"> • NR600 • Ch 8, Sec 2 	<ul style="list-style-type: none"> • NR566 • Ch 8, Sec 2
Stability		<ul style="list-style-type: none"> • Part B • Ch 8, Sec 3 	<ul style="list-style-type: none"> • NR566 • Ch 8, Sec 3
Structural assessment	L ≥ 65 or 90 m (1)	<ul style="list-style-type: none"> • Part B • Ch 8, Sec 4 	<ul style="list-style-type: none"> • Part B • Ch 8, Sec 4
	L < 65 or 90 m (1)	<ul style="list-style-type: none"> • NR600 • Ch 8, Sec 4 	<ul style="list-style-type: none"> • NR600 • Ch 8, Sec 4
Machinery and systems		<ul style="list-style-type: none"> • Part C • Ch 8, Sec 5 	<ul style="list-style-type: none"> • NR566 • Ch 8, Sec 5
Electrical installations and automation		<ul style="list-style-type: none"> • Part C • Ch 8, Sec 5 	<ul style="list-style-type: none"> • NR566 • Ch 8, Sec 5
Fire protection, detection and extinction		<ul style="list-style-type: none"> • Part C 	<ul style="list-style-type: none"> • NR566
<p>(1) Refer to the scope of application of NR600. Note 1: NR566: Hull Arrangement, Stability and Systems for Ships less than 500 GT. NR600: Hull Structure and Arrangement for the Classification of Cargo Ships less than 65 m and Non Cargo Ships less than 90 m.</p>			

3.2 Definitions

3.2.1 Dynamic amplification factor (DAF)

The dynamic amplification factor (DAF) is applied on the static hook load to account for the effect of the external forces due to vessel motions and accelerations, the self motion of the lifting appliance, and the dynamic effects due to lifting in water in case of subsea lifting.

3.2.2 Geometrical limit

The geometrical limit is the configuration of the lifting appliance for which the SWL is defined.

It is possible to specify several SWL corresponding to different geometrical limits.

3.2.3 Handling system

A handling system means any system intended to lifting or pulling of a load.

3.2.4 Minimum breaking load (MBL)

The minimum breaking load of chain, wire ropes and fibre ropes are provided by the manufacturer in accordance with NR216 Marerails and Welding.

3.2.5 Nominal pulling load

The nominal pulling load of a handling system is defined as the maximum load which may be pulled by the system in a safe manner, in kN.

When the handling system is a lifting appliance, the nominal pulling load is equivalent to the Safe Working Load.

3.2.6 Rated line pull (RP)

The rated line pull (RP) of a winch is the maximum rope tension, in kN, that the winch can haul at the relevant layer, in normal service condition, when the drum rotates at its maximum service speed.

3.2.7 Safe working load (SWL)

The safe working load (SWL), in kN, is defined as the maximum static load which may be lifted vertically by the appliance under normal use and within its geometrical limits.

3.2.8 Static Load

The static load, in kN, corresponds to the sum of the static mass of the lifted cargo and its rigging, times the gravity acceleration.

3.2.9 Working load limit (WLL)

The working load limit (WLL), in kN, is defined as the maximum load that a lifting accessory (loose gear) is certified to withstand under normal use and in a given configuration.

4 Documents to be submitted

4.1 General

4.1.1 The documents listed in Tab 2 are to be provided, as a minimum.

4.2 Lifting equipment documentation

4.2.1 Operating manual

The operating manual is to contain the user documentation required by the technical standard the lifting equipment is complying to.

In particular, the operating manual is to contain full information concerning:

- the crane utilization chart, taking into account the stability and structural limitations for each relevant wind and sea state
- all limitations during normal and emergency operations:
 - maximum wind and sea state
 - maximum heel and trim
 - design temperature
 - braking systems
- the description of the equipment
- the design technical standard
- the mass and location of centre of gravity of the main components of the lifting equipment
- all safety devices, including overload protection system, when relevant
- the description of the motion compensation system, when relevant
- the user instructions to operate, erect, dismantle and transport the system
- the factory acceptance tests specification
- the inspection and testing programme of the equipment when installed on-board
- the testing specification of the emergency lowering system for personnel transfer, when relevant
- the diagrams of electrical, hydraulic and pneumatic systems and equipment
- the materials used in construction, welding procedures and extent of non-destructive testing

Note 1: The party applying for classification may also refer to the IMO MODU Code Chapter 12 for the description of the manual content.

4.2.2 Calculation notes

Calculation notes including the items listed below are to be provided for information:

- loading conditions and design loads applied on the lifting equipment
- loads lowering in the foundations
- structural assessment of the connecting bolts between the lifting equipment and its foundations.

Table 2 : Documents to be submitted

No.	Documents to be submitted	I/A (1)
1	Lifting operational restrictions (lifting diagram, limiting environmental conditions, ...)	I
2	Lifting appliance documentation: <ul style="list-style-type: none"> • operating manual (see [4.2.1]) • calculation notes (see [4.2.2]) 	I
3	General arrangement of the ship showing the lifting equipment position during transit and lifting operations	A
4	General arrangement of the lifting equipment showing the control stations	I
Stability		
5	Loading conditions during transit and lifting operations	A
6	Trim and stability booklet as defined in Ch 8, Sec 3	A
Structural assessment		
7	Structural arrangement showing the foundations of the lifting equipment and the hull structure reinforcements	A
8	Scantlings and steel grades of the connecting bolts between the lifting equipment and its foundations	I
9	Structural arrangement of the supporting and locking devices used for transit conditions	A
10	Material specification of the foundations of the lifting equipment	A
11	Cargo securing manual and lashing arrangement (2)	A
12	Welding procedure, welding book of the foundation	A
Machinery		
13	Ballast system diagram when counter ballast is used	A
14	Description of the hydraulic installations of the lifting equipment	A
Electrical installations		
15	General arrangement showing location of electrical installations of the lifting equipment	I
16	Description of electrical arrangement principles, failure scenarios, redundancy principles, emergency arrangement, etc.	I
17	Description of the power supply and control systems of the lifting equipment	A
(1) A : For approval I : For information. (2) For mobile lifting appliance		

SECTION 2

GENERAL ARRANGEMENT

1 General

1.1 Location of lifting appliances

1.1.1 *Lifting appliances should be so located and protected as to reduce to a minimum any danger to personnel, due regard being paid to moving parts or other hazards. Adequate provisions should be made to facilitate cleaning, inspection and maintenance.*

1.2 Position of the crane during navigation

1.2.1 When the lifting appliance is a crane, it is to be possible and to secure it during transit.

SECTION 3

STABILITY AND SUBDIVISION

Symbols

LCG : Longitudinal centre of gravity
 TCG : Transversal centre of gravity
 VCG : Vertical centre of gravity.

1 General

1.1 Application

1.1.1 The provisions of this Section are to be applied to operations involving the lifting of the ship's own structures or for lifts in which the maximum heeling moment due to the lift is greater than that given in the following:

$$M_L = 0,67 \cdot \Delta \cdot GM \cdot \left(\frac{f}{B}\right)$$

Where:

M_L : Threshold value for the heeling moment, in t.m, induced by the lifting equipment and load in the lifting equipment.
 GM : Initial metacentric height, in m, with free surface correction, including the effect of the lifting equipment and load in the lifting equipment.
 f : Minimum freeboard, in m, measured from the upper side of the weather deck to the waterline.
 B : Moulded breadth of the ship, in m.
 Δ : Displacement of the ship, including the lift load, in t.

The stability criteria of this Section also apply to ships which are engaged in lifting operations where no transverse heeling moment is induced and the increase of the ship's vertical centre of gravity (VCG) due to the lifted weight is greater than 1%.

The calculations are to be completed at the most unfavourable loading conditions for which the lifting equipment shall be used.

1.1.2 This Section provides additional stability criteria to be met during lifting operations in exposed or in non-exposed waters.

1.2 Definitions

1.2.1 Ships engaged in lifting operations

Ship engaged in lifting operation means a ship engaged in an operation involving the raising or lowering of objects using vertical force by means of winches, cranes, a-frames or other lifting devices.

Note 1: Fishing vessels are not included in the definition of lifting operations.

1.2.2 Exposed/non-exposed waters

For the purpose of this Section, waters that are not exposed are those where the environmental impact on the lifting operation is negligible. Otherwise, waters are to be considered exposed. In general, waters that are not exposed are calm stretches of water, i.e. estuaries, roadsteads, bays, lagoons; where the wind fetch is six nautical miles or less.

Note 1: Wind fetch is an unobstructed horizontal distance over which the wind can travel over water in a straight direction.

1.3 Loading conditions

1.3.1 The stability criteria stated in this Section shall be satisfied for all loading conditions intended for lifting and with the hook load at the most unfavourable positions. For each loading condition, the weight and centre of gravity of the load being lifted, the lifting appliance, and counter ballast, if any, should be included. The most unfavourable position may be obtained from the load chart and is chosen at the position where the total of the transverse and vertical moment is the greatest. Additional loading conditions corresponding to various boom positions and counter ballast with different filling level, if applicable, may need to be checked.

1.3.2 In lifting operations involving a lifting appliance such as a crane, derrick, sheerlegs or any other similar lifting device:

- the magnitude of the lifted load (P_L) shall be the maximum allowed static load at a given outreach of the lifting appliance
- the transverse distance (y) is the transverse distance between the point at which the vertical load is applied to the lifting appliance and the ship centreline in the upright position
- the vertical height of the load (KC_{load}) is taken as the vertical distance from the point at which the vertical load is applied to the lifting appliance to the baseline in the upright position
- the change of centre of gravity of the lifting appliance(s) need to be taken into account.

1.3.3 In lifting operations not involving a lifting appliance consisting of a crane, derrick, sheerlegs, a-frame or similar, which involve lifting of fully or partially submerged objects over rollers or strong points at or near a deck-level:

- the magnitude of the lifted load (P_L) shall be the winch brake holding load
- the transverse distance (y) is the transverse distance between the point at which the vertical load is applied to the ship and the ship centreline in the upright position
- the vertical height of the load (KG_{load}) is taken as the vertical distance from the point at which the vertical load is applied to the ship to the baseline in the upright position.

1.4 Trim and stability booklet

1.4.1 Loading conditions reflecting the operational limitations of the ship, while engaged in lifting shall be included in the stability booklet.

Use of counter ballast, if applicable, shall be clearly documented, and the adequacy of the ships stability in the event of the sudden loss of the hook load shall be demonstrated.

1.4.2 The following information is to be included in the trim and stability booklet in addition to the information required in Part B, Chapter 3:

- a) Maximum heeling moment for each direction of lift/inclination as a function of the counter-ballast heeling moment, if used, the draught, and vertical centre of gravity.
- b) Where fixed counter ballast is used the following information shall be included:
 - mass of the fixed counter ballast
 - centre of gravity (LCC, TCG, VCG) of the fixed counter ballast.
- c) Loading conditions over the range of draughts for which lifting operations may be conducted with the maximum vertical load of the lift. Where applicable, righting lever curves for both before and after load drop should be presented for each loading condition.
- d) Limitations on cranes operation including permissible heel angles.
- e) operational limitations, such as:
 - maximum safe working load (SWL)
 - maximum radius of operation of all derricks and lifting appliances
 - maximum load moment
 - environmental condition affecting the stability of the ship.
- f) Instructions related to normal operations, including use of counter-ballast.
- g) Instructions such as ballasting/de-ballasting procedures to righting the ship following an accidental load drop.
- h) identification of critical down-flooding openings.
- i) recommendations on the use of roll reduction systems.

- j) drawing of the crane showing the weight and centre of gravity, including heel/trim limitations established by the crane manufacturer.
- k) a crane load chart, with appropriate de-ratings for wave height.
- l) Load chart for lifting operations covering the range of operational draughts related to lifting and including a summary of the stability results.
- m) A crane specification manual provided by the manufacturer shall be submitted separately for information.
- n) the lifting appliance load, radius, boom angle limit table, including identification of offlead and sidelead angle limits and slewing angle range limits and reference to the ship's centreline.
- o) a table that relates the ship trim and heel to the load, radius, slewing angle and limits, and the offlead and sidelead limits.
- p) procedures for calculating the offlead and sidelead angles and the ship VCG with the load applied.
- q) if installed, data associated with a Load Moment Indicator system and metrics included in the system.
- r) if lifting appliance (crane) offlead and sidelead determine the maximum ship equilibrium angle, the stability booklet should include a note identifying the lifting appliance as the stability limiting factor during lifting operations.
- s) information regarding the deployment of (stability) pontoons to assist a lifting operation, if fitted.

The information listed above may be included in other ship specific documentation on board the ship. In that case, a reference to these documents shall be included in the stability booklet.

1.5 Model tests or direct calculations

1.5.1 Model tests or direct calculations, performed in accordance with a methodology acceptable to the Society, that demonstrate the survivability of the ship after sudden loss of hook load, may be allowed as an alternative to complying with the requirements of [2.3] or [3.2.3], provided that:

- the effects of wind and waves are taken into account, and
- the maximum dynamic roll amplitude of the ship after loss of load will not cause immersion of unprotected openings.

1.6 Operational procedures against capsizing

1.6.1 Ships should avoid resonant roll conditions when engaged in lifting operations.

1.7 Guidance on wind force

1.7.1 The curves of wind heeling moments may be drawn for wind forces calculated by the following formula:

$$F = 0,5 C_s C_H P V^2 A$$

where:

- F : Wind force, in N
- C_s : Shape coefficient depending on the shape of the structural member exposed to the wind (refer to Tab 1)
- C_H : Height coefficient depending on the height above sea level of the structural member exposed to wind (refer to Tab 2)
- P : Air specific mass (1,222 kg/m³)
- V : Wind speed, in m/s
- A : Projected area of the exposed surface of the structural member in either the upright or the heeled condition, in m².

1.7.2 Wind forces are to be considered in the transversal direction relative to the ship axis and the value of the wind speed is to be taken as follows:

- In general, a minimum wind speed of 10 m/s (20 knots) is to be used for normal working conditions.
- When the ship is limited in operation, the maximum wind velocity is to be clearly stated in the crane utilization manual.

1.7.3 In calculating the projected areas to the vertical plane, the area of surfaces exposed to wind due to heel or trim such as under decks surfaces, etc., are to be included using the appropriate shape factor. Open truss work may be approximated by taking 30% of the projected block area of both the front and back section, i.e., 60% of the projected area of one side. In the case of columns, the projected areas of all columns is to be included.

1.7.4 The lever for the wind heeling moment is to be taken vertically from the centre of the lateral resistance or, if available, the centre of hydrodynamic pressure, of the underwater body to the centre of pressure of the areas subject to wind loading. When the installation is fitted with dynamic positioning system, the thrusters effect in [1.7.7] is to be considered.

1.7.5 The curve of wind heeling moments may be assumed to vary as the cosine function of ship heel (see Fig 1).

1.7.6 Wind heeling moments derived from wind tunnel tests on a representative model of the ship may be considered as alternatives to the method given in [1.7.1] to [1.7.5]. Such heeling moment determination is to include lift and drag effects at various applicable heel angles.

1.7.7 Thrusters effect

When deemed necessary, for ships on which dynamic positioning is installed, the thrusters negative effect on stability is to be taken into account.

Table 1 : Shape coefficient C_s

Shape	C_s
Spherical	0,40
Cylindrical	0,50
Large flat surface (hull, deckhouse, smooth underdeck areas)	1,00
Drilling derrick	1,25
Wires	1,20
Exposed beams and girders under deck	1,30
Small parts	1,40
Isolated shapes (crane, beam, etc.)	1,50
Clustered deckhouses or similar structures	1,10

Table 2 : Height coefficient C_H

Height above sea level, in m	C_H
0 - 15,3	1,00
15,3 - 30,5	1,10
30,5 - 46,0	1,20
46,0 - 61,0	1,30
61,0 - 76,0	1,37
76,0 - 91,5	1,43
91,5 - 106,5	1,48
106,5 - 122,0	1,52
122,0 - 137,0	1,56
137,0 - 152,5	1,60
152,5 - 167,5	1,63
167,5 - 183,0	1,67
183,0 - 198,0	1,70
198,0 - 213,5	1,72
213,5 - 228,5	1,75
228,5 - 244,0	1,77
244,0 - 259,0	1,79
above 259	1,80

2 Intact stability

2.1 General stability criteria

2.1.1 The stability criteria included herein, or the criteria contained in [2.2], [2.3] or [3], as applicable, is to be satisfied for all loading conditions intended for lifting with the lifting appliance and its load at the most unfavourable positions.

For the purpose of this Section, the lifting appliance, its load(s) and their centre of gravity (COG) should be included in the displacement and centre of gravity of the ship, in which case no external heeling moment/heeling lever is applied.

2.1.2 For the loading conditions stated in [1.3], the following intact stability criteria are to be complied with:

- the equilibrium heeling angle φ_1 shall not be greater than the maximum static heeling angle for which the lifting device is designed and which has been considered in the approval of the loading gear.
- during lifting operations in non-exposed waters, the minimum distance between the water level and the highest continuous deck enclosing the watertight hull, taking into account trim and heel at any position along the length of the ship, shall not be less than 0,50 m.
- during lifting operations in exposed waters, the residual freeboard shall not be less than 1,00 m or 75% of the highest significant wave height H_s , in (m), encountered during the operation, whichever is greater.

2.2 Lifting operations conducted under environmental and operational limitations

2.2.1 For lifting conditions carried out within clearly defined limitations set forth in a), the intact criteria set forth in b) may be applied instead of the criteria included in [2.1]:

- The limits of the environmental conditions should specify at least the following:
 - the maximum significant wave height
 - the maximum wind speed (1 minute sustained at 10 m above sea level), see guidance in [1.7]

The limits of the operational conditions should specify at least the following:

- the maximum duration of the lift
 - limitations in ship speed
 - limitations in traffic/traffic control
- The following stability criteria apply with the lifted load is at the most unfavourable position:
 - the corner of the highest continuous deck enclosing the watertight hull shall not be submerged
 - $A_{RL} \geq 1,40 \times A_{HL}$

Where:

A_{RL} : The area under the net righting lever curve, corrected for crane heeling moment and for the righting moment provided by the counter ballast, if applicable, extending from the angle φ_1 to the angle φ_2 , see Fig 1

A_{HL} : The area below the wind heeling lever curve due to the wind force applied to the ship at the maximum wind speed specified in a), see Fig 1

φ_1 : Equilibrium heeling angle

φ_2 : The lesser between the angle of down flooding (φ_F), the angle of vanishing stability (φ_R), and the second intersection of the righting lever curve with the wind heeling lever curve.

- The area under the net righting lever curve from the equilibrium heel angle, φ_1 , to the down flooding angle, φ_F , or 20° , whichever is less, shall be at least 0,03 m rad.

Figure 1 : Intact criteria under Environmental and Operational limitations

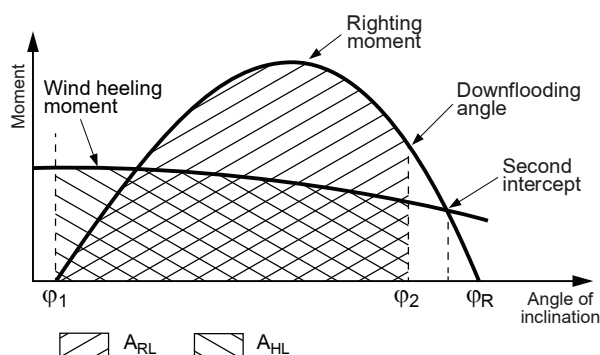

2.3 Intact stability criteria in the event of sudden loss of the lifted load

2.3.1 A ship engaged in a lifting operation and using counter ballasting should be able to withstand the sudden loss of the hook load, considering the most unfavourable point at which the hook load may be applied to the ship (i.e. largest heeling moment).

In this case, the following intact stability criteria are to be complied with in addition to those in [2.1] and [2.2].

2.3.2 For this purpose, the area on the side of the ship opposite to the lift (Area 2) is to be greater than the residual area on the side of the lift (Area 1), as shown in Fig 2, by an amount given by the following:

- Area 2 > 1,4 × Area 1, for lifting operations in waters that are exposed
- Area 2 > 1,0 × Area 1, for lifting operations in waters that are not exposed

Where:

GZ_1 : Net righting lever (GZ) curve for the condition before loss of crane load, corrected for crane heeling moment and for the righting moment provided by the counter ballast if applicable.

GZ_2 : Net righting lever (GZ) curve for the condition after loss of crane load, corrected for the transverse moment provided by the counter ballast if applicable.

φ_{e2} : The angle of static equilibrium after loss of crane load.

φ_i : The angle of down-flooding or the heel angle corresponding to the second intersection between heeling and righting arm curves, whichever is less.

The term "net righting lever" means that the calculation of the GZ curve includes the ship's true transverse centre of gravity as function of the angle of heel.

Note 1: When, after the loss of the lifted load, the ship still heels to the same side, there is no need to comply with above criteria.

Figure 2 : Righting moment curve after sudden loss of load

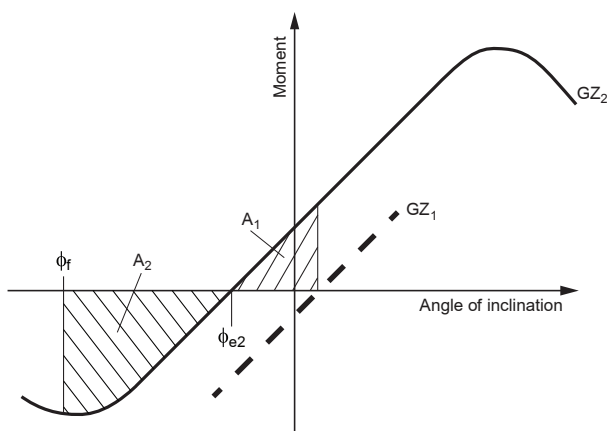

3 Intact stability - alternative method

3.1 General

3.1.1 The criteria in this Article may be applied to a ship engaged in a lifting operation, as an alternative to the criteria in [2.1] to [2.3], as applicable.

For the purpose of this section and the alternative stability criteria set out in [3.2], the lifted load which causes the ship to heel is translated for the purpose of stability calculation to a heeling moment/heeling lever which is applied on the righting lever curve of the ship.

3.1.2 The heeling moment applied to the ship due to a lift and the associated heeling lever should be calculated using the following formulae:

$$HM_{\varphi} = P_L \cdot y \cdot \cos \varphi$$

$$HL_{\varphi} = HM_{\varphi} / \Delta$$

where:

HM_{φ} : heeling moment, in t.m, due to the lift at φ

P_L : vertical load, in t, of the lift, as defined in [1.4.2]

y : transverse distance, in m, of the lift, metres, as defined in [1.4.2]

φ : angle of heel

HL_{φ} : heeling lever, in m, due to the lift at φ

Δ : displacement, in t, of the ship with the load of the lift.

3.2 Alternative stability criteria

3.2.1 The equilibrium heel angle φ_e referred to in this Article means the angle of first intersection between the righting lever curve and the heeling lever curve.

3.2.2 During the lifting operation, the following stability criteria apply:

a) the residual righting area below the righting lever and above the heeling lever curve between φ_e and the lesser of 40° or the angle of the maximum residual righting lever should not be less than:

- 0,080 m rad, if lifting operations are performed in waters that are exposed, or
- 0,053 m rad, if lifting operations are performed in waters that are not exposed.

b) in addition, the equilibrium angle is to be limited to the lesser of the following:

- 10 degrees
- the angle of immersion of the highest continuous deck enclosing the watertight hull
- the lifting appliance allowable value of trim/heel (data to be derived from sidelead and offlead allowable values obtained from manufacturer).

3.2.3 For application of the criteria contained in [2.3] involving the sudden loss of load of the lift in which counter-ballast is used, the heeling levers that include the counter-ballast should be calculated using the following formulae (see Fig 3):

$$CHL_1 = \frac{(P_L \cdot y - CBM)}{\Delta} \cos \varphi$$

$$CBHL_2 = \frac{CBM \cdot \cos \varphi}{\Delta - P_L}$$

Where:

CBM : the heeling moment, in t.m, due to the counter-ballast

CHL_1 : combined heeling lever, in m, due to the load of the lift and the counter-ballast heeling moment at the displacement corresponding to the ship with the load of the lift

$CBHL_2$: heeling lever, in m, due to the counter-ballast heeling moment at the displacement corresponding to the ship without the load of the lift.

For this purpose, the area on the side of the ship opposite from the lift (Area 2) in Fig 3 should be greater than the residual area on the side of the lift (Area 1) by an amount given by the following:

$$\text{Area 2} - \text{Area 1} > K$$

where

- $K = 0,037$ m.rad, for a lifting operation in waters that are exposed, and
- $K = 0,0$ m.rad, for a lifting operation in waters that are not exposed.

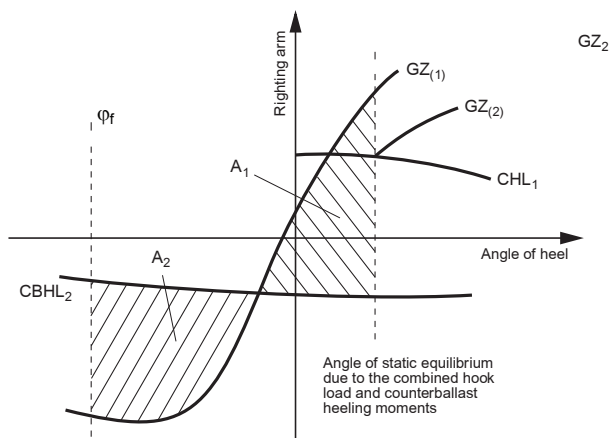
Figure 3 : Alternative criteria - sudden loss of load

4 Additional intact stability criteria for crane overload test

4.1 General

4.1.1 Intact stability check during crane overload testing may be deemed necessary.

As guidance, ships which have onboard cranes of significant size compared to the ship general particulars or/and in case the intact stability particulars during normal crane operations are deemed marginal, the residual intact stability during crane overload test is to be checked and is in principle not to be less than that required by [2.1] and [2.3] as applicable.

5 Alternative damage stability for lifting operations for ships where additional class notation SDS is assigned

5.1 Application

5.1.1 The damage stability criteria specified in this Article may apply to ships operating within a field such as a wind-farm and within the limiting conditions as defined in [5.1.2], in lieu of the damage stability criteria applicable as per Pt B, Ch 3, Sec 3, subject to Society agreement.

5.1.2 These alternative damage stability criteria may be applied when the following conditions are satisfied:

- the ship is operating in an area subject to fully controlled traffic (e.g. wind farm)
- maximum wave significant height and wind speed is limited

5.2 Data to be submitted

5.2.1 The following data are to be submitted:

- limits of the environmental conditions:
 - the maximum significant wave height
 - the maximum wind speed (1 minute sustained at 10 m above sea level)
- limits of the operational conditions:
 - the maximum duration of the lift
 - limitations in ship speed
 - limitations in traffic/traffic control

5.3 Extent of damage

5.3.1 The following extent of damage is to be assumed to occur between effective watertight bulkheads:

- vertical extent: from the baseline upwards without limit
- horizontal penetration measured inboard from the side of the ship perpendicularly to the centre line: 1,5 m.

5.3.2 The distance between effective watertight bulkheads or their nearest stepped portions which are positioned within the assumed extent of horizontal penetration are not to be less than 3 m; where there is a lesser distance, one or more of the adjacent bulkheads are to be disregarded.

5.3.3 Where damage of a lesser extent than defined in [5.3.1] results in a more severe condition, such lesser extent is to be assumed.

5.3.4 All piping, ventilation systems, trunks, etc., within the extent of damage referred to in [5.3.1] are to be assumed to be damaged. Positive means of closure are to be provided at watertight boundaries to prevent the progressive flooding of other spaces which are not managed.

5.4 Alternative damage stability criteria

5.4.1 The following stability criteria in the final stage of flooding are to be complied with:

- The final waterline is to be below the lower edge of any opening through which progressive flooding may occur.
- The equilibrium heeling angle is to be less than 15 degrees, or 17 degrees if no deck immersion occurs
- the righting lever curve is to have a range of positive stability of at least 16° and the GZ max is not to be less than 0.12 m within this range
- unprotected openings are not to become immersed within the prescribed minimum range of positive stability unless the space in question has been included as a floodable space in calculations for damage stability.

SECTION 4 STRUCTURAL ASSESSMENT

1 General

1.1 Application

1.1.1 This Section provides requirements for the structural assessment of the foundations of the lifting equipment, the devices for stowage during transit and the connecting bolts between the lifting equipment and the foundations.

1.1.2 In addition, when the lifting operations are inducing significant hull girder stresses, the hull girder loads due to the lifting operations are to be considered in the hull scantling verification, as specified in [2].

2 Hull girder strength

2.1 Principles

2.1.1 The hull girder strength is to be checked in accordance with Pt B, Ch 6, Sec 2 with the loads due to lifting operations defined in [2.3].

2.2 Hull framing

2.2.1 In general, ships performing lifting operations are to be longitudinally framed.

2.3 Hull girder loads

2.3.1 Still water loads

The still water bending moment and shear forces due to lifting operations are to be added to the moment and shear forces due to the ship weight distribution.

2.3.2 Wave loads

The wave hull girder loads are to be considered with the environmental conditions corresponding to the operational limitations of the lifting equipment, as defined in [5.4.3].

2.3.3 Torsional moment

When deemed necessary, the hull girder strength is to be checked against still water torsional moments induced by lifting operations.

3 Structural design principles

3.1 General

3.1.1 The foundations of the lifting equipment are considered as integral part of hull.

3.1.2 The foundations means the structural elements permanently connected by welding to the hull (for instance crane pedestals, masts, derrick seatings, etc...) to the exclusion of the cranes themselves, derrick booms, ropes, rigging accessories, slewing rings and, generally, any dismountable parts.

3.2 Crane pedestal

3.2.1 In general, crane pedestal is to be continuous through the deck.

In this case, the pedestal is to be checked against through thickness stress in accordance with Pt B, Ch 4, Sec 1, [2.7].

3.2.2 If the pedestal is interrupted on deck, the continuous deck plate is to be made of grade Z steel quality in way of the crane pedestal.

3.3 Mobile lifting equipment

3.3.1 When the lifting equipment is fastened on deck with a lashing arrangement, the description of the sea fastening is to be submitted.

3.3.2 A cargo securing manual, as defined in NI 429, Guidelines for the Preparation of the Cargo Securing Manual, is to be submitted.

3.4 Devices for equipment stowage

3.4.1 The structure of the locking device used for the stowage of the lifting equipment during transit is to comply with the relevant provisions of Part B.

Environmental loads during transit are to be considered.

3.4.2 The hull is to be strengthened in way of the crane stowage device.

3.5 Connecting bolts

3.5.1 The arrangement and scantling of the connecting bolts between the lifting equipment and the foundations are to comply with a recognized standard.

3.5.2 The manufacture, steel grades and installation of bolts and nuts used for the connection of the lifting equipment on the foundation are to comply with a recognized standard.

4 Materials and welding

4.1 Structural category and steel grades for the foundations of the lifting equipment

4.1.1 The steel grade of the structural elements of the foundation is to comply with Pt B, Ch 4, Sec 1, taking into account the structural categories given in Tab 1.

Table 1 : Guidance for structural categories

Category / Class	Structural elements
Secondary / Class I	crane resting support
Primary / Class II	crane pedestal and its foundation
Special / Class III	insert plate of deck plating in way of crane pedestal

4.2 Welding

4.2.1 As a rule, full penetration welding is to be provided between crane pedestal and deck plate.

5 Design loads

5.1 General

5.1.1 The design loads defined in [5.2] to [5.4] are to be provided by the interested party.

5.2 Lifting loads

5.2.1 Vertical loads

As a minimum, the following vertical loads, referring to the coordinate system of the ship, are to be considered:

- the maximum static load equal to the Safe Working Load (SWL) in calm sea, within the geometrical limits of the crane utilisation chart
- the maximum dynamic hoisting loads equal to the maximum Dynamic Amplification Factor (DAF) times the SWL associated with the most severe sea state allowed, within the geometrical limits of the crane utilisation chart
- the maximum holding load corresponding to either the maximum brake capacity or the overload release value

Note 1: The foundation of the lifting equipment is to withstand the design overload value referred to in the rules for certification applicable to the lifting equipment.

- the overload test value of the lifting equipment.

5.2.2 Horizontal loads

Horizontal loads, referring to the coordinate system of the ship, due to lifting operations are to be accounted for in the structural assessment of the foundation.

5.2.3 Dynamic amplification factor

Dynamic amplification factors are applied on static loads to account for the effect of:

- lifting equipment self-motions

- ship motions and accelerations.

The dynamic amplification factors are to be based on the technical standard used for the certification of the lifting equipment.

Additional requirements applicable to subsea lifting are to be complied with, when relevant.

5.2.4 Boom configuration

The design loads are to be applied at the most unfavourable positions of the crane boom within the geometrical limits of the crane utilisation chart.

5.3 Environmental loads

5.3.1 The environmental loads include:

- wind loads acting on the crane and the lifted cargo, as specified in [5.3.2]
- the ship acceleration and motion corresponding to the allowable sea state for a given operation (DAF) as defined in [5.2.3]
- the hull girder wave loads corresponding to the allowable sea state for a given operational limitation, as specified in [5.4.3].

5.3.2 Wind loads

The wind velocity to consider for structural assessment of the foundation are given in Tab 2.

Note 1: the design wind velocity corresponds to an average velocity over 1 minute and taken at 10 m above sea level.

The wind loads acting on the lifted cargo are also to be considered.

Table 2 : Wind velocity

Condition of operation	Wind velocity
Transit	51,5 m/s
Operating	20 m/s or from lifting equipment operating manual, whichever is the greatest

5.4 Hull girder stress

5.4.1 General

The stresses in the longitudinal members of the lifting equipment foundations due to hull girder loads are to be considered.

5.4.2 Still water loads

The still water hull girder loads corresponding to the lifting operations considered are to be evaluated.

5.4.3 Wave loads

The wave hull girder loads corresponding to the maximum sea state defined in the operational limitations of the lifting equipment are to be obtained through an hydrodynamic analysis.

When an hydrodynamic analysis is not performed, the hull girder stresses are to be evaluated through assumptions to be defined in agreement with the Society.

Table 3 : Guidance for the design loading conditions

Loading condition	Load case	Design loads		Environmental load	Basic allowable stress factor (1)
		hoisting load	Hull girder loads		
Transit	Design	none	still water + wave	extreme situation	(2)
Operating - static	Static	SWL	still water only	none	$\alpha = 0,6$
Operating - dynamic	Design	SWL x DAF	still water + wave	operating conditions	$\alpha = 0,8$
Accidental situation	Accidental	Maximum holding load	still water + wave	accidental situation	$\alpha = 1,0$
Testing condition	Testing	Overload test	still water only	none	$\alpha = 0,9$

(1) Factor α is given in this Table as an indication of safety level for each design loading condition.
(2) Structural assessment is to comply with Part B, Chapter 7.

6 Loading conditions

6.1 General

6.1.1 The loading conditions and associated design loads to be considered for the calculation of the foundations are given in Tab 3 for guidance purpose.

6.2 Load cases

6.2.1 The foundations of the lifting appliance and the stowage device are to be designed for at least the load cases defined in [6.2.2] to [6.2.5].

6.2.2 Load cases 1 “static” (still water)

These load cases refer to the most unfavourable combinations of the fixed and operational loads.

The most severe arrangement of operational loads, in particular with respect to moving equipment and dynamic operational loads, is to be considered.

For these load cases no environmental load is taken into account.

6.2.3 Load cases 2 “design” (with environment)

These load cases refer to the most unfavourable combinations of the fixed, operational and environmental loads, including:

- the extreme (severe storm) environmental loads with fixed and associated operational loads
- environmental loads specified by the Operating Manual as constituting limits for a condition of operation of the unit or for the operation of a particular equipment or system, with corresponding fixed and operational loads.

6.2.4 Load cases 3 “accidental”

The accidental loads are to be combined with the fixed, operational and associated environmental loads corresponding to the nature of each accidental load.

6.2.5 Load cases 4 “testing”

Testing loads are to be considered for the design of structures being tested and of the structures supporting the items to be tested, and also, as necessary, for design of overall structure.

7 Allowable stress

7.1 General

7.1.1 For lifting conditions, the foundations of the lifting equipment are to comply with allowable stress criteria defined in the present Article.

7.1.2 Allowable stress for transit conditions are to be taken as per the rules applicable to the hull in Part B.

7.2 Criteria

7.2.1 The equivalent stress σ_c is not to exceed the allowable stress σ_a , for the loading condition considered, according to the following formula:

$$\sigma_c \leq \sigma_a$$

where:

σ_a : Allowable stress, given by:

$$\sigma_a = 1,1 \alpha R_f$$

α : Basic allowable stress factor defined in [7.3].

R_f : Material reference stress defined in [7.4]

σ_c : Equivalent stress defined in [7.5].

7.2.2 When the stresses are obtained through a fine mesh Finite Element Model, the Society may give consideration to small hot spot areas not satisfying above stress criteria, providing that the following criteria are fulfilled:

- The Von Mises stress σ_{VM} at the centroid of elements of a peak stress region of no more than $2t \times 2t$, with t being the thickness of the elements, is to comply with the following criteria:

$$\sigma_{VM} \leq 1,3 \alpha R_f$$

- outside the peak stress region of $2t \times 2t$, the Von Mises stress is to comply with [7.2.1]

- a plastic stress redistribution should be demonstrated to the satisfaction of the Society or obvious from engineering judgement.

7.3 Basic allowable stress factor

7.3.1 The basic allowable stress factor α is to be taken as follows:

- a) In general:
- for load case 1 (“static”): $\alpha = 0,6$
 - for load case 2 (“design”): $\alpha = 0,8$
 - for load case 3 (“accidental”): $\alpha = 1,0$
- b) For specific calculations:
- for load case 4 (“testing”): $\alpha = 0,9$

Note 1: The definitions of the above load cases are provided in [6.2].

7.4 Material strength

7.4.1 The reference stress of material, R_f , is defined by:

$$R_f = \min\left(R_{eG}, \frac{R}{1,2}\right)$$

where:

- R_{eG} : Minimum specified yield stress of the material
 R : Tensile strength of the material.

7.4.2 For hull steels, as defined in NR216 Materials and Welding, R_f is equal to the minimum specified yield strength of steel.

7.4.3 For light alloy materials (aluminium), when used in non-welded constructions, R_f is to be defined taking into account the material properties in the specified condition of delivery. For welded aluminium, R_f is to be taken based on R_{eG} in the annealed condition (refer to NR216 Materials and Welding).

7.5 Equivalent stress

7.5.1 For uniaxial stress condition (e.g. obtained by beam calculation), the following stress components are to be calculated:

- the normal stress σ_1 in the direction of the beam axis
- the shear stress τ_{12} in the direction of the local loads applied to the beam
- the Von Mises equivalent stress, obtained from the following formula:

$$\sigma_{VM} = \sqrt{\sigma_1^2 + 3\tau_{12}^2}$$

Above stresses are the result of the addition of overall stresses and grillage stresses.

7.5.2 For biaxial stress condition (e.g. obtained by finite element calculation with plate elements), the following stress components are to be calculated at the centroid of the mid-plane layer of each element:

- the normal stresses σ_1 and σ_2 in the directions of the element co-ordinate system axes
- the shear stress τ_{12} with respect to the element co-ordinate system axes

- the Von Mises equivalent stress, obtained from the following formula:

$$\sigma_{VM} = \sqrt{\sigma_1^2 + \sigma_2^2 - \sigma_1\sigma_2 + 3\tau_{12}^2}$$

The stresses in the element under study, include the effects of both overall and local loads.

8 Buckling

8.1 General

8.1.1 As possible, the risk of instability (buckling) of structural elements is to be avoided or minimised by adequate structural arrangement (e.g. by avoiding large unstiffened panels or members with high slenderness, by the proper orientation of stiffeners with respect to direction of compressive stresses, etc.) and by detailing (e.g. by providing lateral restraint by tripping brackets, or additional members).

8.1.2 The buckling strength of structural elements is to be ascertained considering the most unfavourable combinations of loads likely to occur, with respect to possible modes of failure.

8.1.3 For unstiffened or ring-stiffened cylindrical shells, both local buckling and overall buckling modes are to be considered for buckling strength assessment.

8.1.4 For stiffened panels, buckling check is to be performed in accordance with NI615 Buckling Assessment of Plated Structures.

The buckling of tubular members is to be checked according to recognized codes or standards.

8.2 Buckling strength criteria

8.2.1 The buckling strength of structural elements is to be ascertained for the effect of stresses resulting from:

- compression induced by axial loads
- compression induced by bending in flanges and web of members
- shear
- external pressure
- localised compression loads.

8.2.2 The buckling capacity of structural elements for each failure mode is to be evaluated following recognised techniques, taking into account:

- potential overall and local failure mode(s)
- due allowance for the manufacturing and/or construction tolerances and residual stresses
- interaction of buckling with yielding
- when relevant, the interaction between overall and local buckling.

8.2.3 A structural element is considered to have an acceptable buckling capacity if its buckling utilisation factor η satisfies the following criterion:

$$\eta \leq \eta_{ALL}$$

with:

$$\eta_{ALL} = \alpha$$

α : Basic allowable stress factor defined in [7.3.1].

The buckling utilisation factor η of the structural member is defined as the highest value of the ratio between the applied loads and the corresponding ultimate capacity or buckling strength obtained for the different buckling modes.

9 Fatigue

9.1 General

9.1.1 Structural details located between the connection flange with the lifting equipment and the strength deck are to be checked in accordance with NI611 Guidelines for fatigue assessment of steel ships and offshore units.

9.1.2 The justification of the long term distribution of fluctuating stress is to be provided.

Note 1: In the absence of data on loading conditions, assumptions may be taken from a recognized standard, e.g. API SPEC 2C Specification for Offshore Pedestal-mounted Cranes.

SECTION 5

MACHINERY AND SYSTEMS

1 General

1.1 Essential service

1.1.1 Electrical installations related to the lifting equipment are to be considered as essential services according to Part C, Chapter 2.

1.2 Hazardous areas

1.2.1 As far as practicable, electrical installations intended for the lifting equipment should not be located in hazardous areas.

1.2.2 Where, due to the operational requirements, some electrical equipment is located in hazardous areas zone 1 or zone 2, it has to comply with the requirements for such equipment in hazardous areas, as defined in Pt C, Ch 2, Sec 1.

2 Position keeping

2.1 General

2.1.1 Vessels granted with the service notation **lifting** are to be able to safely maintain their position during lifting operations. This may be achieved with a passive mooring or a dynamic positioning system in accordance with [2.2].

2.2 Dynamic positioning

2.2.1 When the unit is fitted with a dynamic positioning system, it may be assigned the additional class notation **DYNAPOS** defined in Part A of the classification rules used for the supporting unit.

In this case, lifting units are to be granted with the additional class notation **DYNAPOS AM/AT**, completed by one of the following symbols:

- **R**, when the dynamic positioning is provided with redundancy means. In this case, IMO class 2 equipment is to be used.
- **RS**, when, in addition to symbol **R**, the redundancy is achieved using two systems or alternative means of performing a function physically separated. In this case, IMO class 3 equipment is to be used.

3 Power supply

3.1 General

3.1.1 When the ship main power plant is used to supply the lifting equipment, it shall have sufficient power to run simultaneously:

- the lifting equipment at its maximum rated load and nominal hook velocity
- the essential services
- the dynamic positioning system, when relevant
- the ballast system, when relevant.

3.1.2 The description of the power supply is to be submitted.

4 Lifting equipment controls

4.1 General

4.1.1 The commands on the lifting equipment operating position are to comply with NR526 or another recognized standard.

4.2 Overload prevention

4.2.1 *Each lifting appliance should be fitted, to the satisfaction of the Society, with a safety device to give the operator a continuous indication of hook load and rated load for each radius. The indicator should give a clear and continuous warning when approaching the rated capacity of the crane.*

4.3 Emergency system

4.3.1 Emergency lowering system and emergency stops are to comply with the requirements of the NR526 Certification of lifting appliances onboard ships and offshore units, or another recognized standard.

4.4 Communication means

4.4.1 The communication system is to be arranged for direct 2-way communication between the lifting equipment operating position and:

- the bridge or command centre of the supporting unit
- the dynamic positioning control stand.

SECTION 6

INITIAL INSPECTION AND TESTING

1 General

1.1 Application

1.1.1 The present Section provides requirements for inspection and testing of the lifting installations when first installed onboard or after re-installation.

1.1.2 The inspection and testing requirements of the present Section are provided as a minimum and in addition to the requirements of the rules or standards referred to in the lifting equipment certificate.

Any additional testing may be required to the satisfaction of the attending Surveyor.

1.1.3 These tests are to be conducted according to an inspection and testing specification which is to be submitted to the Society by the interested party.

The Society is to be duly informed of the time and place of the commissioning tests of the lifting equipment.

1.1.4 The specification of the commissioning tests of the lifting equipment should be approved by the certifying authority of the equipment.

2 Onboard testing

2.1 Lifting installations

2.1.1 Before putting into service, the inspection and testing of the lifting equipment is to include, as a minimum:

- a) Verification of the presence onboard of the operating manual as defined in Ch 8, Sec 1.
- b) Inspection of the structural arrangement and scantling of the foundations of the lifting equipment
- c) General examination of the electrical cabling
- d) Functional testing of the main and alternative two-way communication system at the lifting operating position.
- e) Testing of the hydraulic installations
- f) Load tests in accordance with the rules and standards referred to in the lifting equipment certificate:
 - Functional tests
 - Overload tests.

2.1.2 As a rule, all the connections between the supporting unit and the lifting equipment are to be presented for examination by the Surveyor.

SECTION 7

SELF-ELEVATING SHIPS

1 General

1.1 Application

1.1.1 The present Section is applicable to ships or barges fitted with legs and capable of being lowered to the sea bed and of raising the hull above the sea level, hereafter defined as self-elevating ships (see [3.1]).

The present Section addresses the requirements regarding structural assessment of the hull in elevated position, the elevating system and the specific fire safety features.

1.1.2 Self-elevating ships complying with the requirements of this Section are eligible for the assignment of the additional service feature **self elevating** to complete the service notations assigned to the ship as defined in Pt A, Ch 1, Sec 2, [4.9].

1.1.3 The Party applying for classification is to provide the most unfavourable environmental conditions for which the self-elevating ship is designed, as stipulated in [6]. These conditions are to be reported in the Design Criteria Statement defined in [2.2].

All changes of the stipulated environmental conditions are to be submitted to the examination of the Society and the design criteria statement may be modified accordingly after approval of the design for the new conditions and, if applicable, execution of the necessary reinforcements.

1.2 Applicable rules and regulations

1.2.1 In addition to the requirements that ships are to comply with for granting a service notation defined in Pt A, Ch 1, Sec 2, [4.9], ships assigned with the additional service feature **self elevating** are to comply with:

- the requirements for hull structure listed in [1.2.2], taking into account the specific structural requirements for elevated position
- the requirements for machinery, electrical installations, and automation listed in [1.2.2], taking into account the specific requirements for jacking system
- the requirements for fire safety listed in Article [9].

1.2.2 Self-elevating ships are to comply with the relevant requirements of NR534, as specified in:

- Article [5] for structure design principles
- Article [6] for design and environmental conditions
- Article [7] for structural analysis, in elevated position (see [7.1]) or transit and installations conditions (see [7.2])
- Article [8] for jacking system
- Article [10] for construction survey.

Note 1: NR534 Rules for the classification of self elevating units - jackups and liftboats, as amended.

1.2.3 The attention is drawn to certain national or international regulations that may be required by the Administration.

Note 1: e.g. IMO MODU Code (IMO Resolution A.1023(26) - Code for the construction and equipment of mobile offshore drilling unit) applicable to self-elevating units.

2 Classification principles

2.1 Classification limits

2.1.1 Site conditions

It is incumbent to the owner or operator:

- to perform the necessary investigations, including environmental and geotechnical surveys, prior to operating the unit at a given site
- to ascertain that the actual conditions met at the contemplated operating site remain on the safety side when compared to the design data and assumptions (particularly those listed in the design criteria statement, as defined in [2.2]). Such site assessment is not part of the classification.

Classification does not cover the following items:

- assessment of sea bottom conditions and geotechnical investigations
- prediction of footing penetration during preloading
- the stability of the foundation after preloading
- assessment of the possible sea floor movement.

2.1.2 Operating procedures

Classification does not cover the procedures to be used for the unit positioning, leg jacking (lowering or elevating), preloading, jacking and other procedures related to operations.

It is the responsibility of the owner operator to ascertain that the said procedures and their implementation satisfy the design criteria of the ship and the design of the related equipment.

2.2 Design criteria statement

2.2.1 Classification is based upon the design data or assumptions specified by the party applying for classification in accordance with [1.1.3].

A design criteria statement is to list the service(s) performed by the ship and the design conditions and other assumptions on the basis of which class is assigned.

The design criteria statement is issued by the Society, based on the information provided by the party applying for classification.

The design criteria statement is to be incorporated in the operating manual (see [4.2]).

2.2.2 The description of the most unfavourable environmental conditions for which the ship is designed to operate in elevated position, as defined in [1.1.3] is to be included in the design criteria statement as per Article [6].

Figure 1 : Self-elevating ship

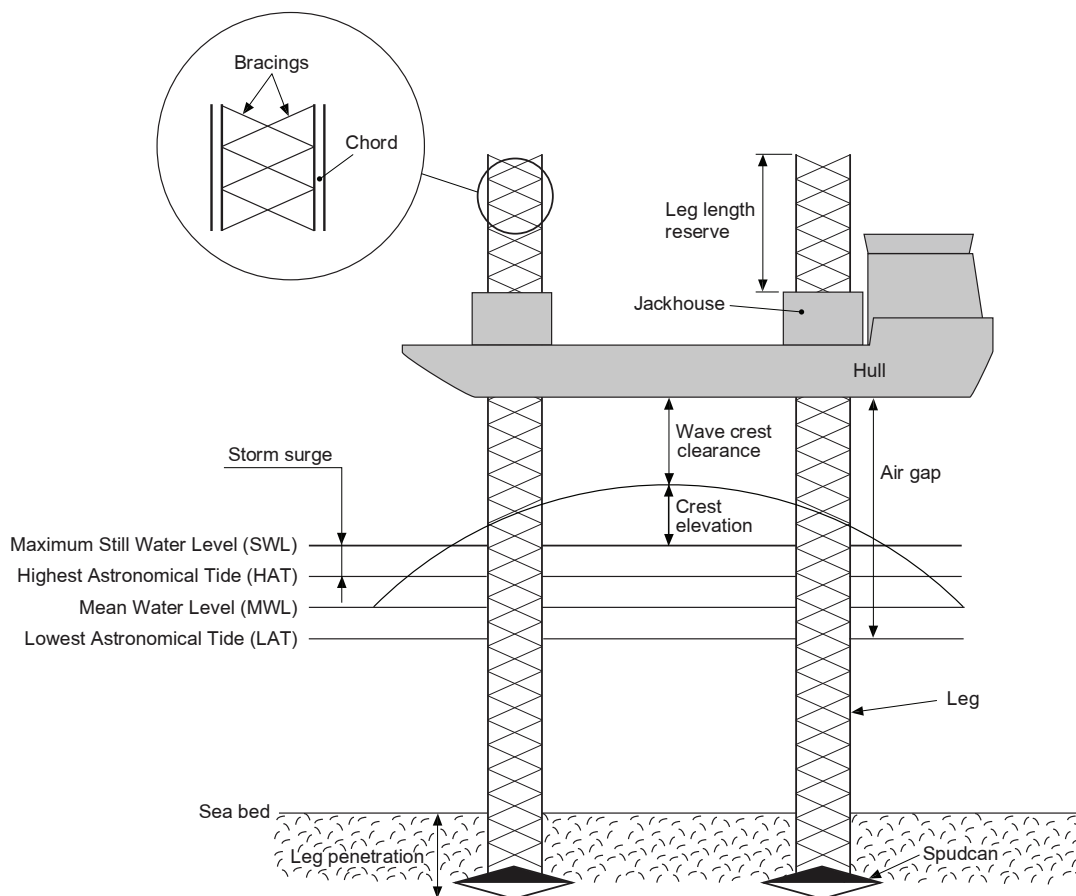

3 Definitions

3.1 Self-elevating ship

3.1.1 A self-elevating ship is a ship or a barge fitted with legs and capable of being lowered to the sea bed and of raising the hull above the sea level (see Fig 1).

The legs may be:

- of a shell or truss type
- equipped with a lower mat, a spudcan, a gravity-based structure or with footings designed to penetrate the sea bed
- vertical or slanted.

3.2 Modes of operation

3.2.1 A self-elevating ship is designed to resist to the loads occurring during working, survival, transit, installation and retrieval modes:

- working mode: the ship is on location, supported on the sea bed to operate, and combined environmental and operational loading are within the appropriate design limits established for such operations
- survival mode: the ship is on location, supported on the sea bed and may be subjected to the most severe environmental loading for which it is designed

- transit mode: the ship moves from one location to another within the appropriate limits the ship is designed to
- installation mode: period when the ship is firstly lowering legs to the sea bed, secondly elevating hull at the required elevation above the sea level, and then preloading the legs to the extreme loading
- retrieval mode: period when the ship is lowering the hull and then elevating legs to be ready for transit mode.

3.3 Water levels, crest elevation and water depth

3.3.1 The reference water levels and crest elevation are defined as follows in the present Section (see Fig 1):

- mean water level (MWL): mean level between the highest astronomical tide (HAT) and the lowest astronomical tide (LAT)
- astronomical tidal range: range between the highest astronomical tide (HAT) and the lowest astronomical tide (LAT)
- maximum still water level (SWL): level at the highest astronomical tide (HAT) including storm surge
- crest elevation: height of wave crest above the SWL.

3.3.2 Except otherwise specified, the reference water depth to be considered is the distance between the sea bed and the SWL.

3.4 Configuration of a self-elevating unit in elevated position

3.4.1 The configuration of a self-elevating ship in elevated position is to be defined based on the site data associated with the ship's services, as specified in accordance with [1.1.3].

3.4.2 The configuration is defined with the following parameters (see Fig 1):

- leg penetration length: the leg penetration length is the maximum leg penetration into the sea bed, including the spudcan if any
- leg length reserve: the leg length reserve is the reserve above the upper guide to avoid any soil settlement or punch through and to provide a contingency in case the penetration exceeds the predicted one
- air gap: the air gap is defined as the distance between the underside of the hull and the lowest astronomical tide (LAT)
- wave crest clearance: the wave crest clearance is defined as the distance between the highest wave crest and the underside of the hull.

4 Documents to be submitted

4.1 General

4.1.1 Documents listed in Tab 1 are to be submitted for approval or information.

4.2 Operating manual

4.2.1 An operating manual, including instructions regarding the safe operation of the ship and of the elevating systems is to be placed on board.

The operating manual is to be, at all times, made available to all concerned. A copy of the operating manual is to be retained ashore by the owner of the ship or by his representatives.

The operating manual is to incorporate a dedicated section containing all the information relating to classification, particularly the environmental, loading and other design criteria, as well as the classification restrictions. The operating manual of a self-elevating ship is also to stipulate the instructions related to the transit conditions, the preloading and the emergency procedures in case of punch through.

It is the responsibility of the party applying for classification to prepare the contents of the operating manual.

Table 1 : Documents to be submitted

No.	Document	A/I (1)
1	Operating manual as defined in [4.2]	A
2	Descriptions of the environmental loads including forces and moments from wind, waves, currents, ice, snow, earthquakes, as applicable as per [6.1]	I
3	Structural analysis of the unit in elevated position	I
4	Calculations of the unit resistance against overturning while resting on the sea bed in elevated position	I
5	Leg strength calculation in floating condition	I
6	Local strength calculations of: <ul style="list-style-type: none"> • legs • leg/hull connection • spudcans or bottom mat, if relevant • leg/spudcan or leg/mat connection, if relevant 	I
7	Fatigue calculations of structural details, when relevant	I
8	Calculations of jacking systems and, if any, fixation systems	I
9	Calculations of segregation of loads between jacking and fixation systems, if relevant	I
10	General arrangement in elevated position	I
11	Drawings of the legs including: <ul style="list-style-type: none"> • for lattice legs: racks, chords, bracings and their connections • for shell type legs: shell plating, stiffeners, stringers, struts, connections of racks with shell plating and supporting leg rack members, potential openings, where relevant 	A
12	Detailed drawings of the racks, if any, including their arrangement in transit and elevating conditions	A
13	Drawings of the footings (spudcans) or mats	A
14	Drawing of the leghouses and their attachments with the hull	A
15	Description of the jacking system as required in NR534, Section 10	(2)
16	Arrangement of the fire-fighting system in elevated position	A
(1)	A : for approval; I : for information	
(2)	As per NR534, Sec 10, Tab 1	

4.2.2 The operating manual is to be submitted to the Society for review, this review being limited to check that the classification related material as mentioned above is consistent with the data given in the design criteria statement defined in [2.2].

4.2.3 The operating manual is to include the following information, where applicable:

- design limitations:
 - during transit (leg arrangement, rig and other equipment sea fastening)
 - during installation (leg lowering, preloading)
 - on site
 - during retrieval (hull lowering, leg retrieval)
- emergency procedures in case of punch through
- preload procedure
- or normal operation, information regarding the preparation of the ship to avoid structural damage during the setting or retraction of legs on or from the seabed, or during extreme weather conditions while in transit, including the positioning and securing of legs
- jacking gear main loading capacity in operating conditions
- maximum loading capacity in case of engaged fixation system
- design criteria statement including the classification restrictions, if any.

5 Structure design principles

5.1 General

5.1.1 The structure design principles applicable for the legs, the leghouses and the spudcans or bottom mat are to be in accordance with NR534, Section 2.

6 Design conditions

6.1 General

6.1.1 The design conditions applicable for the design of the legs, the leghouses, the spudcans or bottom mat and the elevating system, are to be in accordance with NR534, Section 3 as amended by [6.2] for elevated configuration, [6.3] for transit configuration and [6.4] for installation conditions.

6.2 Design conditions in elevated configuration

6.2.1 The most unfavourable wave, current and wind loads to be considered in elevated configuration are to be provided for both working and survival modes.

The area of operation and the description of sea state are to be provided in accordance with NR534, Section 4.

6.2.2 Environmental loads to be considered for accidental conditions such as a broken bracing on a lattice leg may be specially considered subject to the agreement of the Society.

6.3 Transit conditions

6.3.1 Simplified approach

The structural assessment of the legs, the leghouses, the spudcans or bottom mat and the elevating system in transit conditions, is to be based on the motions and accelerations derived from Part B, Chapter 5.

The greatest transversal and longitudinal metacentric heights (GMT and GML) are to be taken from the trim and stability booklet for the calculation of the roll and pitch motions and accelerations.

Note 1: When the condition $L/B > 5$ is not met, a direct assessment of the environmental loads as per [6.3.2] is recommended.

6.3.2 Direct calculation approach

Subject to the agreement of the Society, specific environmental conditions may be considered for the structural assessment of the legs, the leghouses and the spud cans or bottom mat in transit conditions.

In that case, a hydrodynamic analysis is to be performed in accordance with NR534, Appendix 1.

6.4 Installation conditions

6.4.1 The impact loads during installation are to be taken into account as per NR534, Sec 6, [5].

7 Structural analysis

7.1 Structural analysis in elevated position

7.1.1 The structural analysis in elevated position of the legs, the leghouses, the spudcans or bottom mat, the elevating system and the hull, are to be conducted in accordance with NR534, Section 5, considering the wave and wind loads defined in [6.2].

7.1.2 When the self-elevating ship is fitted with lifting appliances intended to be used in elevated position, the lifting loads, defined in Sec 4, [5] are to be taken into consideration for the structural assessment of the elevated hull, the legs and the leghouses.

7.1.3 When fatigue calculations are to be submitted in accordance with NR534, Sec 5, [6.5], the damage ratio criteria are to be selected among the ones applicable to the details accessible for dry inspection.

7.2 Structural analysis in transit conditions and installations conditions

7.2.1 The legs, the leghouses, the spudcans or bottom mat and the self-elevating system are to be designed to sustain the loads induced by the ship motions and accelerations in transit considering the design loads defined in [6.3] and the loads induced by impact, preloading and punch through during installation phase.

7.2.2 The leg structure is to be examined in transit according to the inertia and wind loads distributed along the legs.

7.2.3 The forces and moments induced by the legs are to be considered for the verification of local reinforcements in way of the guides.

7.2.4 The structural assessment to be performed on the legs, the leghouses and the spudcans or bottom mat, are described in NR534, Sec 6, [3], exclusive of the hull and superstructure design requirements.

7.2.5 Spudcans and bottom mat scantling is also to comply with requirements from NR534, Sec 6, [7.2].

8 Jacking system

8.1 General

8.1.1 The design and construction of the jacking system is to comply with the requirements of NR534, Section 10.

8.2 Electricity and automation

8.2.1 The jacking system is to be considered as an essential service.

9 Fire and safety

9.1 Firefighting water supply

9.1.1 At least two water supply sources (sea chests, valves, strainers and pipes) are to be provided and be so arranged that one supply source failure will not put all supply sources out of action.

The following additional fire water supply measures are to be provided:

- in elevated position, water is to be supplied from sea water main filled by at least two submersible pumping systems. One system failure is not to put the other system(s) out of function
- water is to be available while the ship is lifting or lowering. The water stored is to be not less than 40 m³ plus the engines cooling water consumptions before the ship is lifting or lowering. Alternatively, water may be supplied from buffer tank(s) in which the sea water stored is not less than the quantity mentioned above.

10 Construction survey

10.1 Self-elevating system

10.1.1 The construction survey of the self-elevating system, the legs, the leghouses and the spudcans or the bottom mat is performed in accordance with NR534, Section 9.

Part E
**Service Notations for
Offshore Service Vessels and Tugs**

Chapter 9

SEMI-SUBMERSIBLE CARGO SHIPS

SECTION 1	GENERAL
SECTION 2	GENERAL ARRANGEMENT
SECTION 3	STABILITY, SUBDIVISION AND LOAD LINE
SECTION 4	HULL STRUCTURE
SECTION 5	MACHINERY AND SYSTEMS
SECTION 6	ELECTRICAL INSTALLATIONS AND CONTROLS
SECTION 7	SAFETY FEATURES
SECTION 8	INITIAL INSPECTION AND TESTING

SECTION 1 GENERAL

1 General

1.1 Application

1.1.1 Ships complying with the present Chapter are eligible for the assignment of the service notation **semi-submersible cargo ships**, as defined in Pt A, Ch 1, Sec 2, [4.16.8].

The service notation **semi-submersible cargo ship** is to be completed by:

- the additional service feature **heavycargo [AREA1, X1 kN/m² - AREA2, X2 kN/m² - ...]** as defined in Pt A, Ch 1, Sec 2, [4.17.4]
- one of the additional class notations **LI-HG-S2** or **LI-HG-S3**, as defined in Pt A, Ch 1, Sec 2, [6.14.28], in compliance with Ch 9, Sec 3, [1].
- the additional class notation **SDS**, as defined in Pt A, Ch 1, Sec 2, [6.14.11], in compliance with the damage stability requirements specified in Ch 9, Sec 3.

1.1.2 Ships dealt with in this Chapter are to comply with:

- Part A of the Rules
- NR216 Materials and Welding
- applicable requirements according to Tab 1 and specific requirements for initial inspection and testing as defined in Ch 9, Sec 8.

1.2 Scope

1.2.1 General

This Chapter addresses specific requirements to:

- load line and stability criteria for transit and temporary submerged conditions
- ballast system and auxiliary equipment
- structural assessment of the hull in the temporary submerged conditions
- electrical installations
- safety features
- sea trials.

1.2.2 Submerged conditions

a) Stability:

The stability verification required in this Chapter is limited to the assumptions made on some typical floating cargoes as mentioned in the stability booklet.

As a rule, the stability and buoyancy are to be checked before any submersion operation with the actual description of the floating cargo, as specified in Ch 9, Sec 3.

b) Bottom contact:

For units requiring sea bottom contact when submerging, the soil is to be surveyed to obtain information on the character of the soil and to localize obstacles possibly present.

c) Environmental conditions:

Limitations on the environmental conditions (waves, wind and current) to carry out the submersion procedure in a safe and controllable manner, taking into account the actual behaviour of the ship and the floating cargo, are under the responsibility of the operator of the ship.

1.3 Definitions

1.3.1 Transit condition

Transit condition means all ship movements from one geographical location to another.

1.3.2 Temporary submerged condition

Temporary submerged condition means any situation where the semi-submersible cargo ship has its cargo deck under the sea surface.

1.3.3 Maximum submerged draft

The maximum submerged draft is the distance, in m, measured vertically from the moulded base line to the uppermost considered waterlines in temporary submerged conditions at the relevant longitudinal position.

The maximum submerged draft may be:

- the maximum submerged draft at midship taking into account to the uppermost considered waterline with no trim, or
- the maximum submerged draft at fore end (FE) taking into account the maximum negative trim of the ship, or
- the maximum submerged draft at aft end (AE) taking into account the maximum positive trim of the ship.

1.3.4 Cargo deck

The cargo deck is the deck on which the floating cargo is being transported. It is generally equivalent to the freeboard deck as defined in the International Convention on Load Lines 1966, as amended.

1.3.5 Central ballast control station

The central ballast control station is a control station from which the submersion operations are performed.

Table 1 : Applicable requirements

Item		Greater than or equal to 500 GT	Less than 500 GT
Ship arrangement	L ≥ 65 m	<ul style="list-style-type: none"> Part B Ch 9, Sec 2 	<ul style="list-style-type: none"> NR566 Ch 9, Sec 2
	L < 65 m	<ul style="list-style-type: none"> NR600 Ch 9, Sec 2 	<ul style="list-style-type: none"> NR566 Ch 9, Sec 2
Stability		<ul style="list-style-type: none"> Part B Ch 9, Sec 3 	<ul style="list-style-type: none"> NR566 Ch 9, Sec 3
Structural assessment	L ≥ 65 m	<ul style="list-style-type: none"> Part B Ch 9, Sec 4 	<ul style="list-style-type: none"> Part B Ch 9, Sec 4
	L < 65 m	<ul style="list-style-type: none"> NR600 Ch 9, Sec 4 	<ul style="list-style-type: none"> NR600 Ch 9, Sec 4
Machinery and systems		<ul style="list-style-type: none"> Part C Ch 9, Sec 5 	<ul style="list-style-type: none"> NR566 Ch 9, Sec 5
Electrical installations and automation		<ul style="list-style-type: none"> Part C Ch 9, Sec 6 	<ul style="list-style-type: none"> NR566 Ch 9, Sec 6
Safety features		<ul style="list-style-type: none"> Part C Ch 9, Sec 7 	<ul style="list-style-type: none"> NR566 Ch 9, Sec 7
Note 1:			
NR566: Hull Arrangement, Stability and Systems for Ships less than 500 GT.			
NR600 : Hull Structure and Arrangement for the Classification of Cargo Ships less than 65 m and Non Cargo Ships less than 90 m			

2 Documents to be submitted

2.1 General

2.1.1 The documents listed in Tab 2 are to be submitted.

Relevant additional drawings and calculation notes may be requested by the Society in complement to the hereafter mentioned documents.

2.2 Submersion operating manual

2.2.1 A submersion operating manual including the following is to be submitted:

- stability assessment method
- procedure for ballast operations including the filling sequence and the designation of the pumps and tanks used simultaneously
- definition of the ballast capacity with respect to associated type of operation (float-on/float-off or load-on/load-off) and for the different failure modes defined in Ch 9, Sec 5, [2.2]
- commissioning procedure
- contingency plan.

Table 2 : Document to be submitted

No.	Documents to be submitted	I/A (1)
1.1	General arrangement showing the maximum submerged draft	I
1.2	Submersion operating manual	I
Stability		
2.1	Trim and stability booklet	A
2.2	Loading instrument certification booklet	A
2.3	Loading instrument operating procedure when cargo is considered buoyant (see Ch 9, Sec 3)	I
2.4	Justification of the reserve buoyancy	I
Structure		
3.1	Justification of the hull girder loads in limited environmental conditions, when relevant	I
3.2	Description of the connection of the buoyancy casings on deck	A
(1) A : For approval I : For information.		

No.	Documents to be submitted	I/A (1)
3.3	Fatigue calculations, when relevant	A
Machinery and systems		
4.1	Description of the ballast system (single line diagram, specifications, failure modes etc.)	A
4.2	Owner performance request of the ballast system, if any, for each failure mode	I
4.3	Ballast system FMEA	I
4.4	Planned Maintenance System of the ballast system	I
4.5	Overflow tank drainage capacity calculations	I
4.6	Arrangement for hydraulic and pneumatic controlled valves	A
Electrical installations		
5.1	Description of electrical arrangement principles, failure scenarios, redundancy principles, emergency arrangement, etc.	A
5.2	Power supply and control system diagrams of the ballast system	A
5.3	Description of the draft gauging system	I
5.4	Description of the ballast tanks gauging system	I
Safety features		
6.1	Drawing showing the means of escape	A
6.2	Description of the means of fire-fighting for the open deck	A
6.3	Description of the arrangements for life-saving appliances	I
(1) A : For approval I : For information.		

SECTION 2

GENERAL ARRANGEMENT

1 General

1.1 Draft marks

1.1.1 Accurate draft marks are to be positioned on the hull and casings in order to remain visible in temporary submerged conditions and with the maximum trim.

The draft marks and gauges are to be positioned sufficiently at the ends of the ship in order that the trim can be read accurately.

As a rule, the draft scales are to extend above the maximum submerged draft with a height equal to:

- 1,0 m, or
- 0,75L / 100,

whichever is the greater

Draft marks above the summer load line should be highly visible with indicating figures 0,5 m in height, 0,5 m apart.

1.1.2 The maximum submerged draft is to be clearly indicated with a mark near each draft scale.

1.1.3 In addition to the above, automatic draft gauges and alarms are to be provided as defined in Ch 9, Sec 6.

2 Ballast system arrangement

2.1 General

2.1.1 Requirements for the ballast system are given in Ch 9, Sec 5.

2.1.2 Special arrangement to reduce the air entrapped in the ballast tanks are to be considered.

2.2 Central ballast control station

2.2.1 A central ballast control station is to be provided.

2.2.2 The central ballast control station is to be located above the maximum submerged draft and in a space not within the assumed extent of damage referred to in Ch 9, Sec 3, [6].

2.2.3 The central ballast control station is to contain all means necessary to conduct the submersion operation as defined in Ch 9, Sec 5.

SECTION 3

STABILITY, SUBDIVISION AND LOAD LINE

1 General

1.1 Additional class notation SDS

1.1.1 Semi-submersible cargo ships are to be assigned the additional class notation **SDS**, as defined in Pt A, Ch 1, Sec 2, [6.14.11] and are to comply with the requirements for damage stability specified in:

- Article [4] for transit conditions
- Article [6] for temporary submerged conditions.

1.2 Loading instrument

1.2.1 General

A loading instrument is to be provided on-board and accessible from the central ballast control station.

The loading instrument is to comply with Pt B, Ch 10, Sec 2, according to the assigned additional class notation **LI-HG-S2** or **LI-HG-S3**, and also with the additional requirements of the present Section.

Note 1: When the loading instrument allows the definition of a buoyant cargo and/or damage cases, the approval is to be specially considered.

1.2.2 Ballast gauging system

It is recommended that the loading instrument be connected to the ballast tank monitoring system so as to check the stability using the actual filling level values.

1.2.3 Transit conditions

When the cargo is considered buoyant in transit conditions, a procedure describing the input of the new set of data into the loading instrument is to be submitted.

The procedure should include the definition of the new buoyant volume and of the new damage cases under the provisions of [4.2].

1.2.4 Temporary submerged conditions

The loading instrument should be able to perform simulations of the ballast loading sequence and to check the stability criteria for the intermediate conditions during submersion operation.

The loading instrument is to be able to perform stability verification up to the maximum submerged draft and the maximum trim.

1.3 Stability verification in temporary submerged conditions

1.3.1 In addition to the typical loading conditions assumed for the temporary submerged condition in the trim and stability booklet defined in [2.2], specific stability calculations are to be performed before any submersion operation.

A description of the method used for the assessment of stability in the temporary submerged conditions is to be submitted to the Society.

1.4 Submersion procedure

1.4.1 A detailed procedure of the ballasting operation during submersion operation is to be submitted to the Society for the typical loading conditions assumed in the trim and stability booklet.

The procedure should include the sequence of ballast tank filling and stability verification for several intermediate stages.

2 Loading conditions

2.1 Transit conditions

2.1.1 The trim and stability booklet is to include the loading conditions specified in Part B, Chapter 3 for the transit conditions.

Loading conditions with typical cargoes are to be submitted, including the full draft condition.

The windage area of the deck cargo is to be considered.

Buoyancy of the deck cargo may be considered subject to the provisions detailed in Articles [3] and [4].

2.2 Temporary submerged conditions

2.2.1 The trim and stability booklet is to include the following temporary submerged conditions:

- no cargo on deck
- typical loading conditions including buoyant cargo(es) on deck.

The loading conditions are to include initial transit draft and maximum submerged draft with several intermediate stages.

Several trim values are to be considered, including maximum trim.

The free surface effect resulting from partial filling of the ballast tanks is to be considered.

The buoyant volume of the cargo is to be included in the hydrostatic calculations.

Note 1: The stability in temporary submerged conditions is to be checked before any loading or unloading operation.

3 Intact stability in transit conditions

3.1 General

3.1.1 The intact stability in transit condition is to comply with the requirements of Part B, Chapter 3.

3.2 Buoyancy of the cargo

3.2.1 Buoyancy of the cargo may be considered in the stability calculations, on case-by-case basis.

Note 1: Special agreement from the Administration should be granted.

The buoyancy and the watertight integrity of the cargo is to be documented.

3.2.2 For any loading condition involving the buoyancy of the deck cargo, stability calculations with the buoyancy data are to be performed prior to the operation.

3.2.3 Lift-off of buoyant cargo

When the cargo is considered buoyant, assessment of the lift-off of the cargo at heel is to be submitted.

The cargo should not lift-off at an angle of heel less than 20°.

Note 1: Lift-off occurs when the cargo is partially floating, i.e. the tilting moment due to hydrostatic pressure on the cargo is higher than the moment due to gravity.

4 Damage stability in transit conditions

4.1 General

4.1.1 For assignment of the additional class notation SDS, semisubmersible cargo ships are to comply with the applicable requirements of Pt B, Ch 3, Sec 3 taking into account the provisions of:

- [4.2] for the buoyancy of cargo
- [4.3] for type B freeboard
- [4.4] for reduced freeboard.

4.2 Buoyancy of the cargo

4.2.1 Buoyancy of the cargo may be considered in the stability calculations on case-by-case basis.

Note 1: Special agreement from the Administration should be granted.

The buoyancy and the watertight integrity of the cargo is to be documented.

4.2.2 For any loading condition involving the buoyancy of the deck cargo, stability calculations with the buoyancy data are to be performed prior to the operation.

4.3 Type B freeboard

4.3.1 For ships with type B freeboard, damage stability is to comply with the requirements of Pt B, Ch 3, Sec 3 as applicable to cargo ships..

Note 1: When the criteria on the maximum allowable vertical centre of gravity (KG) are not met, compliance with Pt B, Ch 3, App 4 may be considered as an alternative subject to acceptance by the Society. Special agreement from the Administration should also be granted.

Note 2: When the buoyancy of the cargo is taken into account, the damage stability is to comply with the requirements of Pt B, Ch 3, App 4 and the provisions specified in [4.2].

4.4 Type B-60 and B-100 freeboard

4.4.1 For ships which have been assigned reduced freeboard as permitted by Regulation 27 of the International Convention on Load Lines, damage stability is to comply with the requirements specified in Pt B, Ch 3, App 4, taking into account [4.4.2], [4.4.3] and the provisions of IACS UI LL65.

Therefore, compliance with the requirements in [4.3.1] is not required.

Note 1: When the buoyancy of the cargo is taken into account, the damage stability is to comply with the provisions specified in [4.2].

4.4.2 Extent of damage

Units with a type B-60 freeboard are to comply with the requirements of ICLL for one compartment damaged.

Units with a type B-100 freeboard are to comply with the requirements of ICLL for two compartments damaged.

Figure 1 : Extent of damage with protruding buoyant cargo

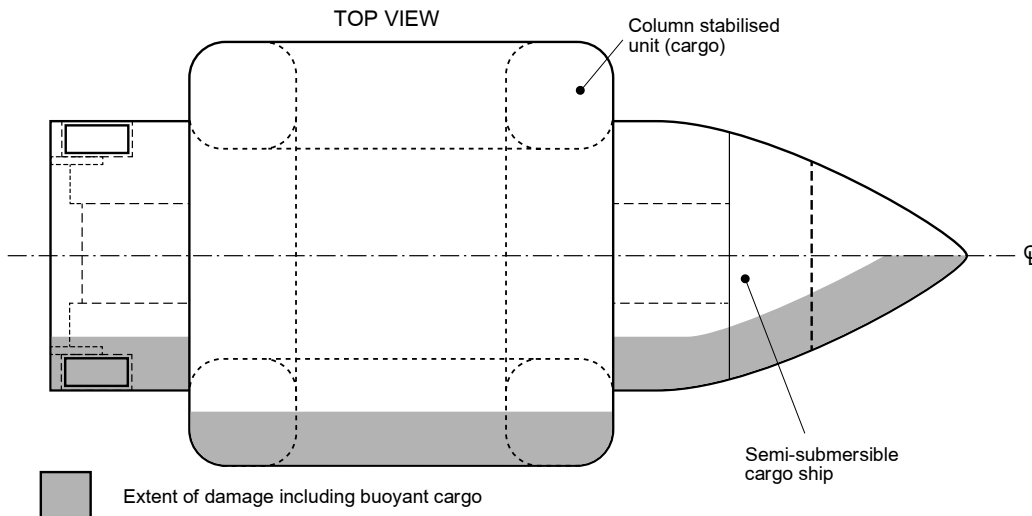

4.4.3 Extent of damage with protruding cargo

When the cargo is considered buoyant and is protruding from the side shell of the ship, the transversal penetration may include the cargo overhang as shown in Fig 1.

In that case, the cargo is considered part of the hull providing the vertical distance between the cargo and the sea level is small, typically less than 4,5 m, and the cargo structure is considered strong enough.

The transverse extent of damage is to be in accordance with ICLL, measured inboard from the side of the ship or from the side of the cargo, on a line perpendicular to the ship's centreline, whichever is the farthest.

Note 1: In specific cases, the definition of the extent of damage may need to be supported by a collision analysis in order to assess the effective protection of the hull provided by the cargo.

5 Intact stability in temporary submerged conditions

5.1 Criteria

5.1.1 The intact stability in temporary submerged conditions is to be checked with the following criteria:

- The metacentric height GM is to be not less than 0,30 m
- The range of stability is to be positive over a range of at least 15°
- Within the range of GZ curve of 15°, the GZ lever maximum is to be not less than 0,10 m
- The maximum GZ value shall not occur at an angle of heel less than 10°
- In equilibrium condition, the distance between the waterline and any weathertight opening through which progressive flooding can occur is to be at least 1,0 m or, with a heel angle of 5°, the weathertight opening is to be above the waterline, whichever is the greatest (see Fig 2).

Figure 2 : Zone of weathertight integrity

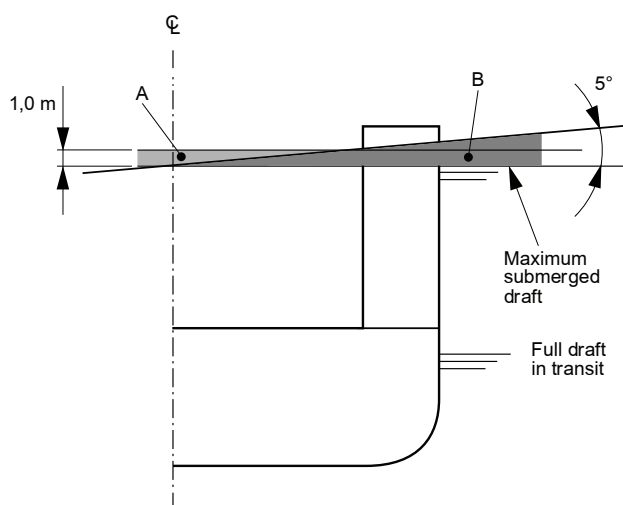

- A : 1.0m - Zone of weathertightness
B : 5 degrees - Zone of weathertightness

6 Damage stability in temporary submerged conditions

6.1 General

6.1.1 For the assignment of the additional class notation SDS, the requirements of the present Article are to be complied with in lieu of Pt B, Ch 3, Sec 3.

6.1.2 Damage stability during temporary submerged conditions as a result of a collision with the cargo or flooding due to a failure of the water ballast system is to be considered.

6.2 Extent of damage

6.2.1 Horizontal penetration

A one-compartment extent of damage is to be assumed on vertical surface adjacent to the exposed deck with:

- longitudinal/ transversal extent of 5,00 m

Note 1: One-compartment extent with a damage length of 5 m imply that a watertight bulkhead may be considered to remain intact provided that the distance with adjacent bulkheads exceeds 5m.

- penetration of 0,76 m
- vertical extent 3,0 m occurring at any level between the exposed deck and 5 m above the maximum submerged draft.

This includes all sides of casings, superstructure bulkheads and hull surface adjacent to the exposed deck within a distance of 2,5 m measured from the superstructure bulkhead.

6.2.2 Vertical penetration

A one-compartment extent of damage is to be assumed on the exposed deck with:

- longitudinal extent of 5,00 m
- transversal extent of 5,00 m
- vertical penetration of 0,76 m.

Note 1: One-compartment extent with a damage length of 5 m imply that a watertight bulkhead may be considered to remain intact provided that the distance with adjacent bulkheads exceeds 5 m.

6.3 Compartment permeability

6.3.1 The permeability of damaged compartments (voids and water ballast) is to be taken as 0,95. The permeability of machinery spaces is to be taken as 0,85.

6.4 Damage criteria

6.4.1 The following damage stability criteria are to be complied with:

- The final waterline after flooding is to be below any non-watertight opening through which progressive flooding may take place
- The equilibrium angle is not to exceed 15° of heel

- c) The righting lever curve is to have a positive range of at least 7° beyond the equilibrium angle
- d) The maximum righting lever is to be at least 0,05 m within the range of positive stability.

6.5 Intermediate stage of flooding

6.5.1 Damage stability at intermediate stages of flooding is to be verified.

7 Temporary submersion

7.1 International Load Line Certificate

7.1.1 Attention is drawn to the temporary submerged condition, for which an exemption with regard to the provisions of ICLL Article 6 should be granted by the Administration.

7.2 Reserve buoyancy

7.2.1 Criteria

The reserve buoyancy at maximum submerged draft is to be assessed.

The reserve buoyancy volume, i.e. the volume with weathertight integrity above the maximum submerged waterline, is to be at least 4,5% higher than the submerged volume.

The reserve buoyancy ratios of the fore end and aft end structures considered separately are to be at least 1,5% higher than the submerged volume.

7.2.2 Alternative

As an alternative to the reserve buoyancy criteria, the ship is to provide sufficient buoyancy and stability at the maximum submerged draft in order to withstand the accidental flood-

ing of any watertight compartment wholly or partially below the waterline in submerged conditions, which is a ballast pump room or a room containing ballast system piping, in compliance with the following criteria:

- a) the angle of inclination after flooding should not be greater than 25°
- b) any opening below the final waterline should be made watertight
- c) a range of positive stability should be provided, beyond the calculated angle of inclination in these conditions, of at least 7°

7.3 Watertight openings

7.3.1 Openings which could be submerged during temporary submerged conditions are to be closed with two effective watertight means to maintain the watertight integrity if one means fails.

The fitting of a second door or hatch of equivalent strength and watertightness is an acceptable arrangement.

A leakage detection device shall be provided in the compartment between the two doors. Drainage of this compartment to the bilges, controlled by a readily accessible screw-down valve, is to be arranged. The outer door is to open outwards.

7.4 Openings

7.4.1 Openings which are to remain open during the temporary submerged conditions, such as the engine room air intakes, are to be provided with remote controlled quick-closing appliances.

SECTION 4

HULL STRUCTURE

Symbols

T_S : Maximum submerged draft, in m, defined in Ch 9, Sec 1, [1.3]

n_S : Navigation coefficient in temporary submerged conditions defined in Tab 1

L, B, C_B : As defined in Pt B, Ch 1, Sec 2

F_M, F_Q, C, H : As defined in Pt B, Ch 5, Sec 2.

1 General

1.1 Application

1.1.1 This Section provides specific requirements for:

- structural assessment of semi-submersible cargo ships in temporary submerged conditions
- ballast tanks pressure when using overflow tanks.

1.2 Internal ballast pressure when using overflow tanks

1.2.1 In order to limit the pressure head in the tanks, the cargo ship may be fitted with an overflow system.

When overflow tanks complying with the relevant provisions of Ch 9, Sec 5 are installed, the pressure head may be taken at the top of the overflow tank instead of the top of the air pipe.

2 Loading conditions

2.1 General

2.1.1 Structural assessment is to be performed according to the applicable requirements of Part B, Chapter 7 for the two following conditions:

- navigation conditions, considering the draught T and the navigation coefficient n
- temporary submerged conditions, considering the draught T_S and the navigation coefficient n_S .

2.1.2 As a minimum, the loading conditions during temporary submerged conditions defined in Tab 1 are to be considered.

Note 1: As an alternative to the rule-based formulae, a direct hydrodynamic analysis may be performed in order to obtain the design wave loads.

Table 1 : Load cases and coefficients n_S during temporary submerged conditions

Loading condition	Description	Draught	n_S
1	Temporary submerged conditions in sheltered area	T_S	0,33
2	Temporary submerged conditions in harbour	T_S	0,20

3 Design loads

3.1 Vertical wave bending moments

3.1.1 The vertical wave bending moments during temporary submerged conditions at any hull transverse section are to be obtained, in kN·m, from the following formulae:

- in hogging conditions:

$$M_{WV, H, D} = 190 F_M n_S C L^2 B C_B 10^{-3}$$

- in sagging conditions:

$$M_{WV, S, D} = -110 F_M n_S C L^2 B (C_B + 0,7) 10^{-3}$$

3.2 Horizontal wave bending moments

3.2.1 The horizontal wave bending moment during temporary submerged conditions at any hull transverse section is to be obtained, in kN·m, from the following formula:

$$M_{WH, D} = 0,42 F_M n_S H L^2 T_S C_B$$

3.3 Ship motions and accelerations

3.3.1 The ship motions and accelerations during temporary submerged conditions are to be obtained in accordance with Pt B, Ch 5, Sec 3 using the navigation coefficient n_S .

3.4 Vertical wave shear forces

3.4.1 The vertical wave shear force during temporary submerged conditions at any hull transverse section is to be obtained, in kN, from the following formula:

$$Q_{W, D} = 30 F_Q n_S C L B (C_B + 0,7) 10^{-2}$$

3.5 Still water and inertial pressures

3.5.1 External boundaries

For temporarily submerged conditions, the still water pressure at any point of the hull is to be the sea pressure at the maximum submerged draft and the dynamic part of the sea pressure may be reduced by n_S .

3.5.2 Watertight boundaries

The still water pressure p_{SF} , in kN/m^2 , and the inertial pressure p_{WF} , in kN/m^2 , to be considered as acting on structural elements located below the deepest equilibrium waterline including doors, hatches and penetrations but excluding side shell structural elements, which constitute boundaries between two compartments not intended to carry liquids shall be based on the deepest equilibrium waterline in damaged transit or damaged temporary submerged conditions.

4 Hull girder strength

4.1 General

4.1.1 The hull girder strength is to be checked in temporary submerged conditions with the hull girder loads defined in [3].

Note 1: Due to the low depth of the hull girder, special attention is to be paid to the requirement regarding the moment of inertia. This requirement is to be satisfied over a minimum length of $0,40 L$ in the midship area.

5 Hull scantlings

5.1 General

5.1.1 Hull scantlings are to be checked in temporary submerged conditions with the design loads defined in [3].

Where intermediate situations are considered more severe due to specific loading conditions of the cargo ship, the scantlings are to be determined according to the most severe situation.

5.2 Structural models

5.2.1 For cargo ships of more than 170 m in length, a finite element analysis is to be performed.

6 Connection of the buoyancy casings

6.1 General

6.1.1 The scantlings of the structures in way of the connection between the hull structure and the buoyancy casings are to be obtained through direct calculations.

6.2 Design loads

6.2.1 Still water loads

Still water pressures are to be calculated taking into account the maximum draught at the location of the buoyancy casing.

6.2.2 Wave loads

The reference value of the ship relative motion h_1 , as defined in Pt B, Ch 5, Sec 4, is to be calculated taking into account the navigation coefficient n_s given in Tab 1 for temporary submerged situation.

Note 1: As an alternative to the rule-based formulae, a direct hydrodynamic analysis may be performed in order to obtain the design wave loads.

6.3 Strength criteria

6.3.1 The local stresses in the elements of the buoyancy casings and in connections with the hull structure are to satisfy the following conditions:

$$\sigma \leq \frac{R_y}{\gamma_m \gamma_r}$$

$$\tau \leq 0,5 \frac{R_y}{\gamma_m \gamma_r}$$

where:

R_y : Minimum yield strength, in N/mm^2

k : Material factor defined in Pt B, Ch 4, Sec 1

γ_m, γ_r : Partial safety factors covering uncertainties regarding, respectively:

- material: $\gamma_m = 1,02$
- resistance: $\gamma_r = 1,30$.

7 Fatigue strength assessment

7.1 General

7.1.1 Fatigue assessment is to be carried out on ships equal to or greater than 170 m in length.

It may also be required on ships less than 170 m in length, if deemed necessary by the Society.

7.1.2 The fatigue life and sea conditions of the ship are to be specified by the Owner, and to be indicated on the midship section drawing.

7.1.3 Fatigue calculations are to be provided to the Society for review.

SECTION 5

MACHINERY AND SYSTEMS

1 General

1.1 Sea pressure

1.1.1 Any equipment on the hull and submitted to the sea pressure is to withstand the pressure due to the maximum submerged draft.

2 Ballast system

2.1 Failure modes and effects analysis

2.1.1 A failure modes and effects analysis (FMEA) is to be performed regarding the ballast system, including its control and monitoring systems.

2.1.2 The FMEA is to address the ballast functions with reference to the different modes of operation defined in [2.2], and regarding float-on / float-off or load-on / load-off operations.

2.1.3 The FMEA method described in Pt F, Ch 2, App 1 may be used as a guidance.

2.2 Failure modes

2.2.1 The ballast system is to be designed in order to meet the safety principles defined in [2.4] in the following failure modes:

- Normal conditions, refer to [2.3.1]
- Degraded conditions, refer to [2.3.2]
- Emergency conditions, refer to [2.3.3].

2.3 Definitions

2.3.1 Normal ballast functions

The normal ballast functions means the design ballast capacity, control and monitoring functions allowing to perform ballasting and de-ballasting procedure of the semi-submersible cargo ship in the intended manner regarding float-on / float-off or load-on / load-off operations.

2.3.2 Degraded ballast functions

The degraded ballast functions means the ballast capacity, control and monitoring functions which remain available in case of a single failure on any active component of the ballast system, as defined in [2.3.4].

The degraded ballast functions are to be defined by the Owner and addressed in the FMEA.

2.3.3 Emergency ballast functions

The emergency ballast functions means the ballast capacity, control and monitoring functions available in case of main source of electrical power failure.

The emergency ballast functions are to be defined by the Owner and addressed in the FMEA.

2.3.4 Active component of the ballast system

An active component of the ballast system means any component of the ballast system which is not a pipe, an electrical cable, a manually controlled valve or a tank.

Active components include the machinery items (pumps, remote controlled valves, filters, etc.) and the control system items (gauges, sensors, switchboards).

2.4 Safety principles

2.4.1 Degraded conditions

Any single failure on an active component in the ballast system is not to lead to a situation where the degraded ballast functions are not met or to unintended flooding.

Note 1: Duplicate of components of the ballast control system may be required.

2.4.2 Emergency conditions

Failure of the main source of electrical power is not to lead to a situation where the emergency ballast functions are not met or to unintended flooding.

2.5 Air pipes

2.5.1 General

Effective means to reduce the air entrapped in the ballast tanks while filling up are to be provided, such as:

- sufficient air holes in tank internal structures, and
- air pipe connected to the highest point during the ballast operations.

Note 1: If the venting system requires operational restrictions (i.e. no trim by the bow when submersing), this should be specifically noted in the submersion operating manual.

2.5.2 Valves

Installation of valves on ballast tank air pipes may be accepted, subject to the following conditions:

- the lay-out of the air pipe system and of the control and supply systems is to be of fail-safe design. In this design, both the risk of flooding and pressurisation are to be taken into account
- an interlock system is provided between filling tank lines and air vent valves.

2.6 Overflow tanks

2.6.1 General

When overflow tanks are fitted to reduce tank pressures in case of overfilling, means are to be provided to drain the overflow tank with sufficient capacity to allow uninterrupted ballasting in normal conditions.

2.6.2 Design pressure and alarms

The design head of pressure considered for the ballast tanks structural assessment may be taken as the overflow tank top level, instead of the top of the air pipe, providing that the following alarms are fitted:

- High level alarm or overflow alarm
- High-High level alarm at max 98% level with shut-down of ballast pumps.

2.6.3 Overflow tank capacity

The overflow tanks are to have a capacity V_{overflow} in m³, not less than:

$$V_{\text{overflow}} = \frac{T_{\text{filling}}}{60} \times (Q_{\text{normal}} - Q_{\text{draintotal}} + Q_{\text{drainpump}})$$

Where:

T_{filling} : Filling time, in minute, to be taken the lesser of:

- 10 min, or
- time matching the design ballast philosophy, or
- when alarms in compliance with [2.6.2] and an automatic draining system are provided, the greatest of:
 - the time elapsed before the drain system is switched on, and
 - 3 min.

Q_{normal} : Ballast rate in normal conditions, in m³/hr

$Q_{\text{draintotal}}$: Total drain pump rate, in m³/hr

$Q_{\text{drainpump}}$: Rate of the largest drain pump, in m³/hr.

Note 1: The rate of the largest pump is considered in order to cope with the single failure of a drain pump.

2.7 Valves and actuators

2.7.1 Every ballast tank is to be provided with remote isolating valves for filling and/or emptying purposes.

The valves are to be able to be operated from the central ballast control station.

An emergency system is to be provided to operate the remote ballast valves.

The isolating ballast tank valves should be closed in case of loss of power.

The flow may be controlled by isolating valve when this valve is designed to reduce the wear associated with sealing surface contact and to maintain the sealing integrity. Other means may be provided to ensure tightness of the valve.

The arrangement for hydraulic and pneumatic controlled valves is to be submitted to the Society.

A speed control system is to be installed for remote valves in order to adjust the operating time. The operating time is to be long enough to avoid any water hammering in the valve and pipe, whilst being in accordance with the manufacturer's recommendation.

The valves and actuators are to be certified as sea side valves.

2.8 Pressurized ballast tanks

2.8.1 Compressed air systems used to fill or empty the ballast tanks are to be specially considered.

Adequate means to control and to mitigate the risks of overpressure are to be provided.

A description of the air pressure system is to be submitted.

2.9 Control and monitoring

2.9.1 Central ballast control station

The central ballast control station defined in Ch 9, Sec 2, [2.2] is to include the following:

- a ballast pump control system
- a ballast pump status-indicating system
- a ballast valves control system
- a ballast valves position-indicating system
- a ballast tank level indicating and monitoring system as defined in Ch 9, Sec 6
- a ballast valve status monitoring system as defined in Ch 9, Sec 6
- a draught indicating system, indicating the draught at each draft scale of the unit or at presentative positions as required by the Society
- a power availability indicating system (main and emergency)
- a ballast system hydraulic / pneumatic pressure-indicating system
- a permanently installed means of communication, independent of the unit's main source of electrical power, between the control station and those spaces containing the ballast pumps and valves or their manual controls, or other spaces that may contain equipment necessary for the operation of the ballast system.

3 Scuppers and sanitary discharges

3.1 Arrangement of scuppers and sanitary discharges

3.1.1 The requirements for scuppers and sanitary discharges are to consider the maximum submerged waterline in lieu of the summer waterline.

SECTION 6

ELECTRICAL INSTALLATIONS AND CONTROLS

1 Emergency source of power

1.1 Essential service

1.1.1 The emergency source of power is to be able to supply the emergency ballast functions defined in Ch 9, Sec 5, [2.3.3] in addition to the other essential services.

2 Controls

2.1 Draft mark automatic gauges

2.1.1 An automatic draft gauging system is to be fitted and the information is to be displayed on the central ballast control station.

In case of submersion to the maximum draft, an automatic visible and audible alarm is to be provided in the central ballast control station.

Note 1: The alarm should be triggered when the mean sea level is higher than the maximum submerged draft.

2.2 Ballast tanks gauging system

2.2.1 The ballast tanks are to be provided with effective means of measuring the filling level. The variations of water ballast level are to be able to be directly observed.

2.2.2 An automatic gauging system is to be provided with the information accessible from the central ballast control station.

2.2.3 The ballast tank filling level is to be continuously monitored during ballasting operations and compared with the provisional values.

2.3 Ballast valves monitoring

2.3.1 The open/close status of valves is to be continuously monitored.

2.4 Communication means

2.4.1 The communication system should be arranged for direct 2-way communication between the central ballast control station and:

- the bridge or command centre of the ship
- the dynamic positioning control stand, when relevant.

SECTION 7

SAFETY FEATURES

1 Fire safety

1.1 General

1.1.1 The cargo deck is to be protected by a fire-fighting system readily accessible in case of fire during a transit.

1.2 Fire hydrants

1.2.1 Fire hydrant located forward and aft of the cargo deck on both sides and with sufficient hose length to reach all the cargo deck area may be considered acceptable as an alternative to requirements of Pt C, Ch 4, Sec 6, [1.2.5].

2 Means of escape

2.1 Transit conditions

2.1.1 Means of safe transfer between aft and fore parts of the ship are to be provided and to be practical in transit conditions.

2.2 Temporary submerged conditions

2.2.1 Internal spaces of buoyancy towers are normally unmanned during temporary submerged conditions.

3 Life-saving appliances

3.1 Temporary submerged conditions

3.1.1 If buoyancy casings are manned during temporary submerged conditions, they should be provided with life-saving appliances suitable for the intended number of persons present on the casing in case of ship abandonment.

SECTION 8

INITIAL INSPECTION AND TESTING

1 General

1.1 Application

1.1.1 The present Section provides requirements for initial inspection and testing specific to the submersion function of the ship at new build stage or after substantial modifications or repair.

The submersion testing is to be conducted according to the submersion procedure submitted to the Society by the Interested Party.

The Society is to be duly informed of the time and place of the commissioning tests of the ballasting equipment and of the submersion trials.

Any additional testing not mentioned in the present Section may be required, to the satisfaction of the attending Surveyor.

2 Commissioning

2.1 At quay

2.1.1 Before putting the equipment into service, the inspection and testing should include, as a minimum, the:

- a) verification of the presence on board of the submersion procedure as defined in Ch 9, Sec 1
- b) examination of the connection of the buoyancy casings with the hull
- c) functional testing of the ballasting system including its control and monitoring system for the different modes of operation defined in Ch 9, Sec 5, [2.2]
- d) functional testing of the interface between the ballast system and the loading instrument
- e) examination of ballast tank gauging system.

2.2 Sea trials

2.2.1 Submersion trials are to be performed under survey of the Society.

Part E
**Service Notations for
Offshore Service Vessels and Tugs**

Chapter 10

STANDBY RESCUE VESSELS

SECTION 1	GENERAL
SECTION 2	RESCUE ARRANGEMENT, ACCOMMODATION AND EQUIPMENT
SECTION 3	HULL AND STABILITY
SECTION 4	MACHINERY
SECTION 5	ELECTRICAL INSTALLATIONS
SECTION 6	FIRE PROTECTION

SECTION 1 GENERAL

1 General

1.1 Application

1.1.1 Ships complying with the requirements of this Chapter are eligible for the assignment of the service notation **standby rescue** as defined in Pt A, Ch 1, Sec 2, [4.9.10].

This service notation may be completed by the number of survivors that the vessel is intended to carry. Depending on the vessel operation area, the Society may adapt the requirements regarding the survivors accommodation and/or the safety equipment. In such a case, this service notation is to be completed by the number of survivors that the vessel is intended to carry and by the vessel operation area, as for example: **standby rescue (150 survivors, Guinea Gulf)**.

1.1.2 Ships dealt with in this Chapter are to comply with:

- Part A of the Rules
- NR216 Materials and Welding
- applicable requirements according to Tab 1.

1.1.3 Other standards

In order to ensure consistency with other applicable standards (e.g. national authorities, industry bodies), the require-

ments of this chapter may be completed or replaced, as necessary, by the following recognized standards upon agreement of the Society:

- Canada Atlantic Standby Vessel Guidelines (June 2015 or later)
- DMA Guidance on standby vessels (July 1997 or later)
- NMA Regulation N°853 on standby vessels (December 2014 or later)
- NMA Instructions to Class regarding Standby Vessels (February 2014 or later)
- NOGEPa Industry Guideline n°6 (V1 - June 2004 or later)
- Oil & Gas UK - Emergency Response & Rescue Vessel - Management Guidelines (Issue 5 - April 2013 or later)
- Oil & Gas UK - Emergency Response & Rescue Vessel - Survey Guidelines (Issue 6 - April 2013 or later)

Standards not listed above may be considered by the Society on a case-by-case basis.

Deviations from the requirements of this chapter and/or application of additional requirements based on recognized standards are to be specified in a memoranda.

Table 1 : Applicable requirements

Item		Greater than or equal to 500 GT	Less than 500 GT
Ship arrangement	L ≥ 90 m	<ul style="list-style-type: none"> • Part B • Ch 10, Sec 2 (1) 	<ul style="list-style-type: none"> • NR566 • Ch 10, Sec 2 (1)
	L < 90 m	<ul style="list-style-type: none"> • NR600 • Ch 10, Sec 2 (1) 	<ul style="list-style-type: none"> • NR566 • Ch 10, Sec 2 (1)
Hull	L ≥ 90 m	<ul style="list-style-type: none"> • Part B • Ch 10, Sec 3 	<ul style="list-style-type: none"> • Part B • Ch 10, Sec 3
	L < 90 m	<ul style="list-style-type: none"> • NR600 • Ch 10, Sec 3 	<ul style="list-style-type: none"> • NR600 • Ch 10, Sec 3
Stability		<ul style="list-style-type: none"> • Part B • Ch 10, Sec 3 	<ul style="list-style-type: none"> • NR566 • Ch 10, Sec 3
Machinery and cargo systems		<ul style="list-style-type: none"> • Part C • Ch 10, Sec 4 	<ul style="list-style-type: none"> • NR566 • Ch 10, Sec 4
Electrical installations		<ul style="list-style-type: none"> • Part C • Ch 10, Sec 5 	<ul style="list-style-type: none"> • NR566 • Ch 10, Sec 5
Automation		<ul style="list-style-type: none"> • Part C 	<ul style="list-style-type: none"> • NR566
Fire protection, detection and extinction		<ul style="list-style-type: none"> • Part C • Ch 10, Sec 6 	<ul style="list-style-type: none"> • NR566 • Ch 10, Sec 6
<p>(1) In addition to rescue and accommodation arrangement, Ch 10, Sec 2 includes requirements for safety and medical equipment. Note 1: NR566: Hull Arrangement, Stability and Systems for Ships less than 500 GT NR600: Hull Structure and Arrangement for the Classification of Cargo Ships less than 65 m and Non Cargo Ships less than 90 m.</p>			

1.2 Documents to be submitted

1.2.1 In addition to the provisions of Pt B, Ch 1, Sec 3, the following documents are to be submitted to the Society for approval:

- Arrangement of rescue areas
- Rescue and safety equipment plan showing position and quantity of all life safety rescue equipment on board
- Towing arrangement, if applicable
- Structural arrangement of the winch and its remote control of the quick-release device for opening under load, if applicable
- Structural arrangement of the hook and its remote control of the quick-release device for opening under load, if applicable
- Connection of the towing system (winch and hook) with the hull structures, if applicable
- Arrangement of windows with information on type of glass, frames, including references of standards and deadlights where applicable.

SECTION 2

RESCUE ARRANGEMENT, ACCOMMODATION AND EQUIPMENT

1 General

1.1 Wheelhouse

1.1.1 Manoeuvrability

The vessel is to be easily manoeuvrable from the wheelhouse by one person only.

1.1.2 Visibility

The wheelhouse is to be designed to offer an unobstructed view at all times on:

- the rescue zone, including ship's sides
- the helicopter winching area
- the areas where the fast rescue crafts (FRCs) are launched and recovered

2 Rescue equipment and facilities

2.1 Rescue zone

2.1.1 The vessel is to be arranged on both sides with a rescue zone extending minimum 8 m in length.

2.1.2 The rescue zone is to be located sufficiently far away from the propellers or thrusters and clear of any ship side discharges up to 2 m below the summer waterline.

2.1.3 It should be arranged so that the necessity of vertical transfer is kept to a minimum.

2.1.4 The area is to be clearly marked on the ship's side in contrasting colours.

2.1.5 The ship's side in way of the rescue zone shall be free of any obstruction like fenders or anything which may harm climbing survivors.

2.1.6 Dedicated lighting is to be provided along the rescue zone.

2.1.7 Deck area in way of the rescue zone should preferably be free from air pipes, valves, smaller hatches, etc., and covered with anti-slip coating. However, when this becomes impractical, proper arrangement is to be provided as protection against personnel injury.

2.1.8 Bulwarks and railing in way of the rescue zone shall be of the type that are easy to open or remove, to enable direct boarding on the deck.

2.1.9 Unobstructed stretcher access from the rescue zone to the accommodation is to be provided and covered with anti-slip coating.

2.2 Scrambling net

2.2.1 Each rescue zone is to be provided with a scrambling net made for climbing the ship's side from the sea or from the Fast Rescue Craft.

It is to be made of corrosion resistant and non-slip material, hang clear of the ship's side and extend below the waterline level at lightest draught.

2.3 Retrieval device

2.3.1 The vessel is to be equipped with a power-assisted device operated from the vessel and capable of recovering at least 5 able or disabled persons from sea directly onto the vessel.

This could be achieved by means of a crane with a rescue basket. In such case, attention is drawn to Flag State requirements that may have to be complied with for the crane.

2.4 Rescue hooks

2.4.1 At least two poles with rounded-off hooks at ends are to be provided to assist survivors alongside the vessel.

2.5 Fast Rescue Craft (FRC)

2.5.1 The vessel is to be equipped with at least one SOLAS approved fast rescue boat for standby duties, arranged and maintained to be permanently ready for use under severe weather conditions, and which may be accepted as forming part of the ship's life saving appliances. The launching arrangement shall also be SOLAS approved.

2.6 Safety equipment

2.6.1 Vessels having a gross tonnage lower than 500 are to be provided with the following minimum safety equipment:

- 1 line-throwing appliance with not less than 4 projectiles and 4 lines
- 1 daylight signalling lamp
- 6 lifebuoys, 4 being with self-igniting electric light and buoyant line (SOLAS type approved)
- 1 SOLAS type approved immersion suit for each crew member
- 1 SOLAS type approved lifejacket for each crew member plus 25% of the number of survivors for which the vessel is intended to carry
- 1 whistle and 1 bell
- Equipment for at least 2 surface swimmers.

2.7 Helicopter winching area

2.7.1 The vessel is to be arranged with a designated helicopter winching area on deck for transferring personnel or stretchers.

2.7.2 The area is to be at least 5 m in diameter and free of any obstructions. It is to be arranged away from superstructures.

2.7.3 The area is to be painted in yellow colour and illuminated so that it remain visible by the helicopter at all times.

2.7.4 Unobstructed stretcher access from the accommodation to the helicopter winching area is to be provided.

2.7.5 The winching area and the passage leading thereto are to be provided with anti-slip coating.

3 Survivors spaces

3.1 General

3.1.1 A dedicated space is to be available for treatment, reception and accommodation of survivors. The space is to be sheltered from bad weather and direct sun radiation and provided with lighting, ventilation, or heating according to the intended zone of operation.

3.2 Decontamination area

3.2.1 An area equipped with a shower system for cleaning survivors and crew before proceeding to the reception area is to be arranged.

3.3 Reception area

3.3.1 An enclosed area with access to accommodations is to be arranged for medical assessment and registration of survivors, as well as for the distribution of supplies.

3.4 Treatment room

3.4.1 A dedicated room of at least 15 m² is to be equipped to provide first-aid to injured persons.

3.5 Accommodations

3.5.1 10% of the number of survivors the vessel is rated for are to be able to lie down. Permanent seating is to be provided for the rest of them.

3.5.2 In an emergency, survivors may be accommodated in crew accommodation except for sanitary accommodation, galley, berths for the master and 2 crew members, the radio room, the wheelhouse and main access passageways which should be kept clear.

3.5.3 Sanitary facilities are to be available exclusively for the survivors. At least one installation comprising a toilet, a wash basin and a shower is to be provided per group of 50 survivors.

3.6 Non-survivors

3.6.1 Facilities to store corpses out of sight of survivors in a cool and ventilated space, with arrangements for shelving and securing, is to be provided. This storage space should permit maximum discretion for other survivors.

4 Medical equipment and supplies

4.1 Water

4.1.1 Per group of 50 survivors, there is to be a minimum of 0,85 tonnes of fresh water for washing, showering, etc., and a minimum of 0,7 tonnes of potable water.

4.1.2 Water heating facilities are to be able to feed all the showers dedicated to the survivors with 40°C water for at least 2 hours.

4.2 Meals

4.2.1 It should be possible to serve soup or stew to the rated number of survivors for at least 2 days.

4.3 Sundries

4.3.1 The vessel is to be provided with blankets, towels, socks and disposable coveralls in sufficient quantity for the number of survivors the vessel is intended to carry.

4.4 Medical equipment

4.4.1 The treatment room is to be adequately equipped and furnished to perform the largest possible scope of medical operations on board. Typical required medical equipment are listed below for guidance:

- surgical instruments and suture materials
- resuscitation equipment
- various examination, surveillance and treatment equipment
- dressings and bandages
- stretchers
- medicaments.

SECTION 3

HULL AND STABILITY

1 Stability

1.1 General

1.1.1 The stability of the ship is to be in compliance with the requirements in Ch 3, Sec 3.

1.2 Additional requirements for towing operations

1.2.1 The stability of vessels intended to perform towing operations is to be in compliance with Ch 1, Sec 2, [3].

1.3 Additional requirements for water spraying

1.3.1 Vessels fitted with a water spraying system are to meet the stability requirements of Ch 4, Sec 2.

2 Hull

2.1 Vessels intended for towing operations

2.1.1 Vessels intended to perform towing operations are to comply with the requirements of Ch 1, Sec 3, [2.2] to Ch 1, Sec 5, [2.1].

2.2 Lifeboat towing

2.2.1 In addition to the optional towing capabilities mentioned in [2.1.1], the vessel is to be fitted with simple and suitable arrangements for connecting and towing lifeboats and liferafts, such as towing points and towlines.

SECTION 4

MACHINERY

1 General

1.1 Application

1.1.1 In addition to the present Section, the relevant requirements of Ch 3, Sec 5 are to be applied.

1.2 Ship propulsion and manoeuvrability

1.2.1 Propulsion redundancy

The vessel shall be equipped with at least two independent propulsion systems, which may be either:

- single screw propulsion with variable pitch or reversible gearbox and a 360° azimuth thruster unit
- twin screw propulsion and a side thruster
- two azimuth thrusters
- any equivalent system approved by the Society on a case-by-case basis.

1.2.2 Minimum speed

During sea trials, it is to be verified that in calm water conditions, the vessel is to be capable of attaining an ahead speed of at least 10 knots, and 4 knots with the most powerful propulsion system out of action.

1.2.3 Stationary position and manoeuvring capabilities

The vessel is to be capable of manoeuvring at low speed and maintaining position in currents, waves and winds expected in the operations areas.

1.3 Exhaust pipes

1.3.1 The exhaust outlets from engines are to be fitted as high as practicable above the upper deck and are to be provided with spark arresters.

SECTION 5

ELECTRICAL INSTALLATIONS

1 General

1.1 Electrical installations

1.1.1 The electrical installations are to allow the simultaneous use of all the electric equipment needed for rescue operations.

1.1.2 The vessel is to be provided with sufficient emergency power sources to allow the rescue operations to continue for at least 1 hour after failure of the main power supply.

1.2 Searchlight

1.2.1 A searchlight is to be available on each side of the vessel and operated from the navigation bridge. The searchlights are to be able to provide an illumination of 50 lux at a distance of 250 m.

SECTION 6

FIRE PROTECTION

1 General

1.1 Additional requirements for water spraying

1.1.1 Vessels fitted with a water spraying system are to meet the applicable requirements of Ch 4, Sec 4.

Part E
**Service Notations for
Offshore Service Vessels and Tugs**

Chapter 11

ACCOMMODATION UNITS

- SECTION 1 GENERAL**
- SECTION 2 ELECTRICAL INSTALLATIONS AND AUTOMATION**
- SECTION 3 FIRE PROTECTION, DETECTION AND EXTINGUISHION**
- SECTION 4 SPECIFIC REQUIREMENTS FOR SHIPS ASSIGNED WITH THE
ADDITIONAL SERVICE FEATURE SPXXX CAPABLE**

SECTION 1 GENERAL

1 General

1.1 Application

1.1.1 Ships complying with the present Chapter are eligible for the assignment of the service notation **accommodation**, as defined in Pt A, Ch 1, Sec 2, [4.9.5].

The service notation **accommodation** is to be completed by at least one of the following additional service features:

- **SPxxx**, as detailed in [1.1.2], when the ship complies with the SPS Code
- **SPxxx-capable**, as detailed in [1.1.3], when accommodation facilities may be added as separate modules during the service life of the ship, with a view to complying with the SPS Code.

The additional service feature **SPxxx** or **SPxxx-capable** are completed by the additional service feature **MOU**, as detailed in [1.1.4], when the ship complies with IMO MODU Code.

Examples of notations are given below:

accommodation SP70

accommodation SP120-capable

accommodation SP80 SP240-capable MOU

1.1.2 Additional service feature SPxxx

Ships intended for the accommodation of industrial personnel and provided with all facilities for this purpose are to be assigned with the additional service feature **SPxxx**, as defined in Pt A, Ch 1, Sec 2, [4.17.1] where **xxx** is the total number of persons onboard.

Industrial personnel carried on board ships assigned with the service notation **accommodation** and the additional service feature **SPxxx** may be regarded as special personnel for the purpose of IMO Code of Safety for Special Purpose Ships.

1.1.3 Additional service feature SPxxx-capable

Ships on which facilities for the accommodation of industrial personnel may be added as separate modules are to be assigned with the additional service feature **SPxxx-capable**, where **xxx** is the total number of persons onboard once the modules have been added.

Industrial personnel carried on board ships assigned with the service notation **accommodation** and the additional service feature **SPxxx-capable** may be regarded as special personnel for the purpose of IMO Code of Safety for Special Purpose Ships.

Ships assigned with the additional service feature **SPxxx-capable** are to comply with the requirements of Ch 11, Sec 4.

1.1.4 Additional service feature MOU

Ships complying with the relevant requirements of IMO MODU Code are to be assigned the additional service feature **MOU**.

Note 1: IMO MODU Code means the Code for the Construction and Equipment of Mobile Offshore Drilling Units, published by the International Maritime Organization.

The requirements for the assignment of this additional service feature consist of IMO MODU Code Ch.2 to 9 and Ch.13.

1.2 Applicable rules

1.2.1 Ships dealt with in this Chapter are to comply with:

- Part A of the Rules
- NR216 Materials and Welding
- Applicable requirements according to Tab 1.

1.2.2 Ships less than 500 GT will be specially considered by the Society.

Table 1 : Applicable requirements

Item		Rule reference
Ship arrangement	L ≥ 65 or 90 m (1)	<ul style="list-style-type: none"> • Part B • Ch 11, Sec 4 (2)
	L < 65 or 90 m (1)	<ul style="list-style-type: none"> • NR600 • Ch 11, Sec 4 (2)
Stability		<ul style="list-style-type: none"> • Part B • Ch 11, Sec 4 (2)
Structural assessment	L ≥ 65 or 90 m (1)	• Part B
	L < 65 or 90 m (1)	• NR600
Machinery and systems		<ul style="list-style-type: none"> • Part C • Ch 11, Sec 4 (2)
Electrical installations and automation		<ul style="list-style-type: none"> • Part C • Ch 11, Sec 2 • Ch 11, Sec 4 (2)
Fire protection, detection and extinction		<ul style="list-style-type: none"> • Part C • Ch 11, Sec 3 • Ch 11, Sec 4 (2)
<p>(1) Refer to the scope of application of NR600 (2) When the notation SPxxx-capable is assigned. Note 1: When the notation SPxxx is assigned, reference is made to Pt A, Ch 1, Sec 2, [4.17.1]. Note 2: NR600 : Hull Structure and Arrangement for the Classification of Cargo Ships less than 65 m and Non Cargo Ships less than 90 m</p>		

1.3 Definitions

1.3.1 Crew

Crew means all persons carried on board the ship to provide navigation and maintenance of the ship, its machinery, systems and arrangements essential for propulsion and safe navigation or to provide services for other persons on board.

1.3.2 Industrial personnel

Industrial personnel means all persons who are transported or accommodated on board for the purpose of offshore industrial activities performed on board other vessels and/or other offshore facilities. Industrial personnel are:

- Not less than 16 years of age, and
- Physically fit, and
- Properly equipped and familiarized with ship general layout, ship safety procedures and ship safety equipment as detailed in IMO Resolution MSC.418(97).

2 Documents to be submitted

2.1 General

2.1.1 The documents listed in Tab 2 are to be provided, as a minimum.

Table 2 : Documents to be submitted

No.	Documents to be submitted	I / A (1)
1	General arrangement showing the location of the accommodations	I
2	Structural fire protection plan and insulation details	A
3	General arrangement of electrical installation	I
(1) A : For approval I : For information.		

SECTION 2

ELECTRICAL INSTALLATIONS AND AUTOMATION

1 Interaction with operational ships or units

1.1 Application

1.1.1 The requirements of this article apply to ships that may be located close to drilling or oil or gas production units.

1.2 Emergency Shutdown

1.2.1 Arrangements are to be provided to ensure the selective disconnection of the following equipment, in the event of an emergency situation where explosion hazard may extend up to the ship:

- Ventilation systems
- Non-essential electrical apparatuses
- Essential electrical apparatuses
- Main generator prime movers
- Emergency apparatuses, including the emergency generators, except those certified for installation in Zone 1

Note 1: In the case of ships with dynamic positioning systems as a sole means of position keeping, special consideration may be given to the selective disconnection of shutdown of machinery and equipment associated with maintaining the operability of the dynamic positioning system.

1.2.2 Disconnection or shutdown is to be possible from at least two widely separated locations.

1.2.3 Shutdown systems that are provided to comply with [1.2.1] are to be so designed that the risk of unintentional stoppages caused by malfunction in a shutdown system and the risk of inadvertent operation of a shutdown are minimized.

1.2.4 Services to be operable after emergency shutdown

Equipment which is located in spaces other than enclosed spaces and which is capable of operation after shutdown as given in [1.2.1] are to be suitable for installation in zone 2 locations. Such equipment which is located in enclosed spaces is to be suitable for its intended application to the satisfaction of the Society. At least the following facilities are to be operable for half an hour after an emergency shutdown:

- a) emergency lighting:
 - at every muster and embarkation station on deck and over sides
 - in all service and accommodation alleyways, stairways and exits, personnel lift cars and personnel lift trunks
 - in the machinery spaces and main generating stations including their control positions
 - in all control stations, machinery control rooms, and at each main and emergency switchboard
- b) navigation aids
- c) general alarm system
- d) public address system
- e) battery-supplied radiocommunication installations.

SECTION 3

FIRE PROTECTION, DETECTION AND EXTINCTION

1 Interaction with operational ships or units

1.1 Application

1.1.1 The requirements of this article apply to ships that may be located close to drilling or oil or gas production units.

1.2 Structural integrity

1.2.1 The superstructures and deckhouses containing accommodation spaces are to have external boundaries made of steel.

1.2.2 In addition, if the ship may be located within 100m of a drilling or oil or gas production unit, the external boundaries of superstructures or deckhouses containing accommodation spaces are to have fire integrity as follows:

- If the boundary is located within 30m of the centre of the rotary table of a drilling unit or of the process or storage area of a production unit, it is to have A-60 fire integrity
- If the boundary is located within 100m of the centre of the rotary table of a drilling unit or of the process or storage area of a production unit, it is to have A-0 fire integrity

1.3 Installation layout

1.3.1 Accommodation spaces and control stations are to be located outside hazardous areas, taking into account hazardous areas on drilling or oil or gas production units in close proximity.

1.3.2 Ventilation intakes are to be located so as to minimize the risk of ingress of gas or smoke in the event of a gas release or of a fire on drilling or production units in close proximity.

SECTION 4

SPECIFIC REQUIREMENTS FOR SHIPS ASSIGNED WITH THE ADDITIONAL SERVICE FEATURE SPXXX-CAPABLE

1 General

1.1 Application

1.1.1 The present Section provides requirements for ships on which accommodation modules are intended to be added at a later stage.

1.1.2 Ships complying with the present Section are eligible for the assignment of the additional service feature **SPxxx-capable** defined in Ch 11, Sec 1, [1.1.3].

1.1.3 The additional service feature **SPxxx-capable** applies when the accommodation modules are not installed on board.

1.1.4 When the accommodation modules are installed on board, the additional service feature **SPxxx** is to be activated in replacement of **SPxxx-capable**. For this purpose, the Society will check that the additional modules and the ship including the additional modules are in compliance with the applicable requirements.

1.1.5 In case xxx is above 240, the feasibility of granting the additional service feature **SPxxx-capable** will be assessed on a case-by-case basis by the Society. In this respect, specific attention is to be paid to the requirements of [2.3].

1.1.6 Provisions applicable to the ship in general are to be considered during the ship design and construction, although the additional accommodation modules are not installed on board yet.

1.2 Documents to be submitted

1.2.1 A description of a likely arrangement of the ship with the additional accommodation modules is to be provided for information, including the following information as a minimum:

- List of equipment to be added onboard together with the accommodation modules, if any
- General description of the modules, number and arrangement onboard
- Assumed electrical power balance

1.2.2 For the purpose of the stability assessment, the following documents are to be provided by the ship designer, taking into account a likely arrangement for the accommodation modules:

- General Arrangement
- Intact and damage stability calculations

2 Design review

2.1 Specific requirements

2.1.1 The requirements of Part B and Part C of the present Rules are to be complied with, as applicable.

2.1.2 The ship without the additional accommodation module is to comply with the specific requirements listed in Tab 1.

2.2 Stability assessment

2.2.1 When the accommodation modules are installed onboard and in order to activate the additional service feature **SPxxx**, it is to be demonstrated that the actual module arrangement, if different from the initially assumed arrangement, is properly covered by the initial stability assessment.

2.3 Safe Return to Port

2.3.1 The provisions of [2.3] apply to ships assigned with the additional service feature **SPxxx-capable** and for which:

- xxx is greater than 240 and
- L_{LL} as defined in Pt B, Ch 1, Sec 2, [3.2] is greater than or equal to 120m or the ship includes three or more main vertical zones as defined in Pt C, Ch 4, Sec 1, [3.25]

2.3.2 Special attention is to be given to redundancies on at least the following systems, with a view to complying with the requirements for **SRTP** additional service feature:

- propulsion
- steering systems and steering-control systems
- navigational systems
- systems for fill, transfer and service of fuel-oil
- internal communication
- external communication
- fire main system
- fixed fire-extinguishing systems
- fire and smoke detection system
- bilge and ballast system
- power-operated watertight and semi-watertight doors
- systems intended to support safe areas
- flooding detection systems

2.3.3 When the accommodation modules are installed onboard and together with the activation of the additional service feature **SPxxx**, compliance with the requirements for the additional service feature **SRTP** is to be demonstrated.

Table 1 : Applicable requirements for notation SPxxx-capable

Item	Reference requirement	Provisions to be applied depending on the total number of persons on board (POB) (1)		
		POB < 240		240 ≤ POB
Arrangement	<ul style="list-style-type: none"> Pt B, Ch 2, Sec 1, [1.1] Pt B, Ch 2, Sec 1, [6.1.2] Pt B, Ch 2, Sec 2, [1.1] 	<ul style="list-style-type: none"> Pt B, Ch 2, Sec 1, [1] to Pt B, Ch 2, Sec 1, [5], Pt B, Ch 2, Sec 2, considering the industrial personnel as crew	<ul style="list-style-type: none"> Pt B, Ch 2, Sec 1, [1] to Pt B, Ch 2, Sec 1, [5] Pt D, Ch 11, Sec 2, Pt B, Ch 2, Sec 2 considering the industrial personnel as passengers	
Stability	Pt B, Ch 3, Sec 1, [1.2]	<ul style="list-style-type: none"> Part B, Chapter 3 Pt D, Ch 11, Sec 3, [2.3.14] considering the industrial personnel as crew		<ul style="list-style-type: none"> Part B, Chapter 3 Pt D, Ch 11, Sec 3 considering the industrial personnel as passengers
	<ul style="list-style-type: none"> Pt B, Ch 3, Sec 3, [1.2.1] Pt B, Ch 3, Sec 3, [4.1.2] Pt B, Ch 3, App 2, [1.2.14] 	<ul style="list-style-type: none"> Pt B, Ch 3, Sec 3 Pt D, Ch 11, Sec 3, [2.3] (except Pt D, Ch 11, Sec 3, [2.3.12]), considering the industrial personnel as passengers, and where A is not to be less than: <ul style="list-style-type: none"> for POB ≤ 60: 0,8 R for 60 < POB < 240: linear interpolation between 0,8 R and R 	<ul style="list-style-type: none"> Pt B, Ch 3, Sec 3 Pt D, Ch 11, Sec 3, [2.3] considering the industrial personnel as passengers, and where A is not to be less than R	
		POB ≤ 60	60 < POB ≤ 240	240 < POB
Machinery and systems	Pt C, Ch 1, Sec 10, [6.7.1]	Pt D, Ch 11, Sec 4, [1], considering industrial personnel as passengers		
	Pt C, Ch 1, Sec 11, [1.1.2]	Pt C, Ch 1, Sec 11, considering the ship as a cargo ship		Pt C, Ch 1, Sec 11, considering the ship as a passenger ship
Electrical installations and automation	Pt C, Ch 2, Sec 3, [3.6.3], item g)	For ships having a length greater than 50m		
	Pt C, Ch 2, Sec 3, [2.3.21]	–	Pt D, Ch 11, Sec 5, [2]	
	Pt C, Ch 2, Sec 3, [3.4]	–	Pt D, Ch 11, Sec 5, [1.2.1]	
Fire protection, detection and extinction	Pt C, Ch 4, Sec 1, [2.3.2]	Part C, Chapter 4, considering the ship as a cargo ship	Part C, Chapter 4, considering the ship as a passenger ship carrying not more than 36 passengers	Part C, Chapter 4, considering the ship as a passenger ship carrying more than 36 passengers
(1) POB in the total number of persons on board, indicated as xxx in the SPxxx-capable additional service feature				

Part E
**Service Notations for
Offshore Service Vessels and Tugs**

Chapter 12

PIPE LAYING UNITS

- SECTION 1 GENERAL**
- SECTION 2 STABILITY AND SUBDIVISION**
- SECTION 3 STRUCTURAL ASSESSMENT**
- SECTION 4 INITIAL INSPECTION AND TESTING**

SECTION 1 GENERAL

1 General

1.1 Application

1.1.1 Ships complying with the present Chapter are eligible for the assignment of the service notation **pipe laying** as defined in Pt A, Ch 1, Sec 2, [4.9.7].

1.1.2 Ships dealt with in this Chapter are to comply with:

- Part A of the Rules
- NR216 Materials and Welding
- applicable requirements according to Tab 1 and specific requirements for initial inspection and testing as detailed in Ch 12, Sec 4.

1.2 Scope

1.2.1 The present Chapter addresses the requirements regarding the structural assessment of the foundations of the pipe laying equipment and the stability of the ship during pipe laying operations.

1.2.2 The certification of the pipe laying system is not covered by the present Chapter. Certification of pipe laying system pieces of equipment may be considered independently as detailed in [2.2].

2 Pipe laying system

2.1 General

2.1.1 The term pipe laying system is used herein to designate the system used for assembling and installing rigid or flexible pipelines to the seabed.

Pipe laying systems include:

- S lay systems
- J lay systems
- Flex lay systems
- Reel lay system

with the following typical pieces of equipment:

- stingers, towers, ramps and tensioners
- wheels, reels, davits and chutes
- carousels, baskets and pipe racks
- winches, ropes and sheaves
- pipe handling systems and clamps.

2.2 Certification of the pipe laying equipment

2.2.1 At the request of the Party applying for classification, the pipe laying system pieces of equipment may be certified and covered under the scope of classification, provided that the additional class notation **OHS** is assigned to the ship.

Table 1 : Applicable requirements

Item		Greater than or equal to 500 GT	Less than 500 GT
Ship arrangement	L ≥ 65 or 90 m (1)	• Part B	• NR566
	L < 65 or 90 m (1)	• NR600	• NR566
Stability		• Part B • Ch 12, Sec 2	• NR566 • Ch 12, Sec 2
Structural assessment	L ≥ 65 or 90 m (1)	• Part B • Ch 12, Sec 3	• Part B • Ch 12, Sec 3
	L < 65 or 90 m (1)	• NR600 • Ch 12, Sec 3	• NR600 • Ch 12, Sec 3
Machinery and systems		• Part C	• NR566
Electrical installations and automation		• Part C	• NR566
Fire protection, detection and extinction		• Part C	• NR566
(1) Refer to the scope of application of NR600			
Note 1:			
NR566: Hull Arrangement, Stability and Systems for Ships less than 500 GT			
NR600: Hull Structure and Arrangement for the Classification of Cargo Ships less than 65 m and Non Cargo Ships less than 90 m			

3 Documents to be submitted

3.1 General

3.1.1 The documents listed in Tab 2 are to be provided.

3.2 Pipe laying equipment documentation

3.2.1 Operating manual

The operating manual is to contain full information concerning:

- the pipe laying operational limitations, for each relevant wind and sea state
- all limitations during normal and emergency operations taking into account the ship stability and structure:
 - maximum wind and sea state
 - maximum heel and trim
 - design temperature
 - maximum pay load on the pipe lay equipment
- the description of the equipment
- the design technical standard, if any

- the description of the safety devices
- the user instructions to operate, erect, dismantle and transport the system
- the inspection and testing programme of the equipment.

3.2.2 Calculation notes

Calculation notes including the items listed below are to be provided for information:

- loading conditions and design loads applied on the supporting structure of the pipe laying equipment including:
 - maximum safe working loads with respect to environmental conditions
 - dynamic amplification factors
 - maximum holding loads
- the mass and location of centre of gravity of the main components of the pipe laying equipment
- loads lowering in the foundations
- structural assessment of the connecting bolts between the lifting equipment and its foundations.

Table 2 : Documents to be submitted

No.	Documents to be submitted	I / A (1)
1	Pipe laying operational restrictions (pay load, limiting environmental conditions, ...)	I
2	Pipe laying equipment documentation: <ul style="list-style-type: none"> • operating manual (see [3.2.1]) • calculation notes (see [3.2.2]) 	I
3	General arrangement of the ship showing the pipe laying equipment position during transit and operations	I
4	General arrangement of the pipe laying equipment showing the control stations	I
Stability		
5	Loading conditions during transit and pipe laying operations	A
6	Trim and stability booklet including operational loading conditions, when relevant	A
Structural assessment		
7	Structural arrangement showing the foundations of the equipment and the hull structure reinforcements (stinger, lay tower, winches, etc.)	A
8	Scantlings and steel grades of the connecting bolts between the equipment and its foundations	I
9	Material specification of the foundations of the equipment	A
10	Welding procedure and welding book of the foundation	A
(1) A : For approval I : For information.		

SECTION 2

STABILITY AND SUBDIVISION

1 General

1.1 Application

1.1.1 The stability requirements described in this Section may be applied to ships when the pipe laying operation induces significant heeling moment.

1.1.2 In that case, the stability criteria required for lifting operation and described in Ch 8, Sec 3 are to be applied in order to check the residual stability during pipe laying operations.

For that purpose, the term “lifting” is to be replaced by “pipe laying”.

1.2 Loading conditions

1.2.1 When relevant, the stability criteria are to be satisfied for all pipe laying operational conditions and with the pipe laying load at the most unfavourable positions.

SECTION 3

STRUCTURAL ASSESSMENT

1 General

1.1 Application

1.1.1 This Section provides requirements for the structural assessment of the foundations of pipe laying equipment supported by the hull structure, such as:

- stingers
- lay tower
- ramps
- reels
- davits
- chutes
- carousels
- pipe racks
- winches and sheaves.

2 Hull girder strength

2.1 Principles

2.1.1 When the pipe laying operations induce significant hull girder stresses, the hull girder loads due to the pipe laying operations are to be considered in the hull scantling verification, as defined in Ch 8, Sec 4, [2].

Note 1: For that purpose, the term “lifting” is to be replaced by “pipe laying”.

3 Materials and welding

3.1 Structural category and steel grades for the foundations of the pipe laying equipment

3.1.1 The steel grade of the structural elements of the foundation is to comply with Pt B, Ch 4, Sec 1, taking into account the structural categories given in Tab 1.

Table 1 : Guidance for structural categories

Category / Class	Structural elements
Primary / Class II	Hull supporting structure
Special / Class III	Insert plate of deck plating or hull shell in way of stingers, davits or lay tower

4 Pipe laying equipment foundations

4.1 General

4.1.1 The foundations of the pipe laying equipment and the connecting bolts between the equipment and the foundations are to comply with the relevant requirements applicable to lifting units defined in Part E, Chapter 8, i.e.:

- for design loads: Ch 8, Sec 4, [5]
- for loading conditions: Ch 8, Sec 4, [6]
- for allowable stress: Ch 8, Sec 4, [7]
- for buckling: Ch 8, Sec 4, [8]
- for fatigue: Ch 8, Sec 4, [9].

Note 1: For that purpose, the term “lifting” is to be replaced by the term “pipe laying”.

4.2 Connecting bolts

4.2.1 The arrangement and scantling of the connecting bolts between the pipe laying equipment and the foundations are to comply with a recognized standard.

4.2.2 The manufacture, steel grades and installation of bolts and nuts used for the connection of the lifting equipment on the foundation are to comply with a recognized standard.

SECTION 4

INITIAL INSPECTION AND TESTING

1 General

1.1 Application

1.1.1 The present Section provides requirements for inspection and testing of the pipe laying installations when first installed onboard or after re-installation.

1.1.2 These tests are to be conducted according to an inspection and testing specification to be submitted to the Society by the interested party.

The Society is to be duly informed of the time and place of the commissioning tests of the pipe laying equipment.

1.1.3 Any additional testing may be required to the satisfaction of the attending Surveyor.

2 Onboard testing

2.1 Pipe laying installations

2.1.1 Before putting into service, the inspection and testing of the pipe laying installations should include, as a minimum:

- a) Verification of the presence onboard of the operating manual as defined in Ch 12, Sec 1
- b) Inspection of the structural arrangement and scantlings of the foundations of the pipe laying equipment
- c) Load tests in accordance with the pipe laying equipment testing program.

2.1.2 As a rule, all the connections between the supporting ship and the pipe laying equipment are to be presented for examination by the Surveyor.



Move Forward with Confidence

Marine & Offshore
Le Triangle de l'Arche - 8 Cours du Triangle - CS 50101
92937 Paris La Defense Cedex - France
Tel: + 33 (0)1 55 24 70 00
<https://marine-offshore.bureauveritas.com/bv-rules>
© 2019 Bureau Veritas – All rights reserved